

FNS-1800 Juicer

Operator Manual



January 2026



FNS-1800 Juicer Operator Manual

Copyright © JBT Marel Corporation 2026

JBT Marel Corporation
400 Fairway Avenue
Lakeland, FL 33801
(863) 683-5411

email: freshnsqueezeservice@jbt.com

Manual No. FNS-0015-060-EN

Safety Information	4
Safety Instructions	5
Technical Specifications	6
General Information	7
Operating Instructions	11
Cleaning Instructions	14
Maintenance	21
Periodic Inspection	24
Troubleshooting-Operator	26
Illustrated Parts List	29

Important Safety Information

You can help prevent personal injury and/or property damage.

Please read this manual carefully before operating the FNS-1800 Juicer. DO NOT attempt any operation until understanding machine functions.

If uncertainty remains after studying this manual, please contact:

JBT Marel Corporation

400 Fairway Avenue
Lakeland, FL 33801
863.683.5411

email: freshnsqueezeservice@jbt.com

or

The local JBT Marel Corporation service representative in your country.

We're here to help. With proper handling, the Fresh 'n Squeeze FNS-1800 Juicer will provide safe, efficient and convenient service for years to come.

Revision History

Manual Code	Rev. No.	Date	Pages	Change History
FNS-0015-060-EN	A	1/8/2026	Entire manual	Initial release

Safety Labels

The safety labels shown below appear on the FNS-1800 Juicer. They provide essential instructions on how to avoid possible hazards.

Please, for your safety: FOLLOW THOSE INSTRUCTIONS AT ALL TIMES.

Should the FNS-1800 Juicer safety labels become damaged or unreadable, contact JBT Marel Corporation for replacement labels.

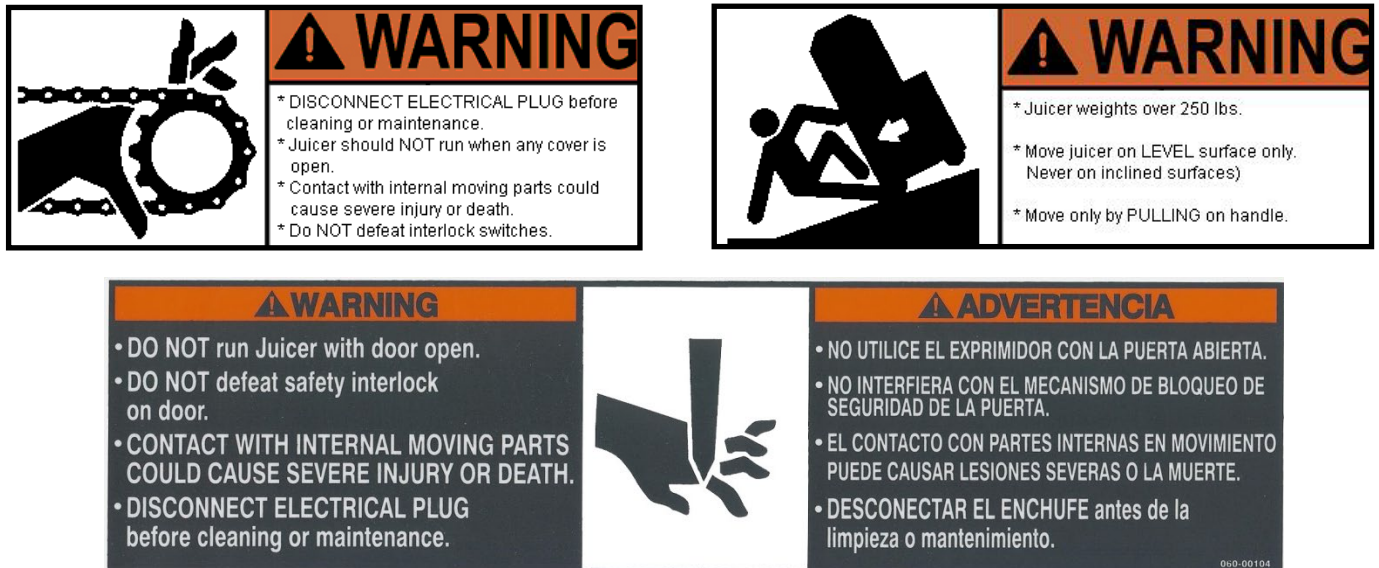

Safety Instructions

Carefully review the following safety instructions. Make them a habit when using the FNS-1800 Juicer.

1. If FNS-1800 Juicer continues to run when any access cover is open, interlock switch is defective.
Turn Juicer off and unplug immediately. Call for service.
2. **NEVER** attempt to make any safety device inoperative.
3. **NEVER** operate or perform maintenance or repair work on FNS-1800 Juicer when taking any kind of drug or sedative, when under the influence of alcohol, or when fatigued.
4. **ALWAYS** check adjustment of all nuts, bolts, and screws after installation, repair, or periodic maintenance.

Technical Specifications

Fruit Size: 2-1/2" to 3-1/4" major diameter
Oranges - FL: 125 to 80 count
Oranges - CA: 138 to 88 count
Lemons, Limes: 138 to 115 count
Holding capacity: 15 to 20 lbs. of fruit
Speed: 18 fruit/minute
Waste container capacity: 15 to 20 lbs.

Electrical Specifications

115V 60HZ Single Phase
or
230V 50HZ Single Phase

Shipping Specifications

Height: 36"
Width: 21"
Depth: 26"
Weight: 215 lbs.

General Information

The JBT Marel Corporation FNS-1800 Juicer is designed to provide years of dependable service. It uses a unique patented design to extract every available amount of juice from the fruit with the least amount of peel oil. The peel is completely separated from the juice and juice sacs before being compressed and strained.

The machine will juice oranges, lemons, limes, tangerines, etc., without changing or adjusting parts. In fact, different varieties of fruit can be juiced to create various fruit juice blends.

Clean up is simple, requiring disassembly of only five parts. All waste material - peel, membranes, and seeds - is collected for easy removal and disposal.

The FNS-1800 Juicer is solidly built using heavy-duty components in all assemblies, including the drive. It is simple to operate and uses a minimal number of parts.

ALWAYS follow cleaning and maintenance schedules in this manual to prevent equipment damage.

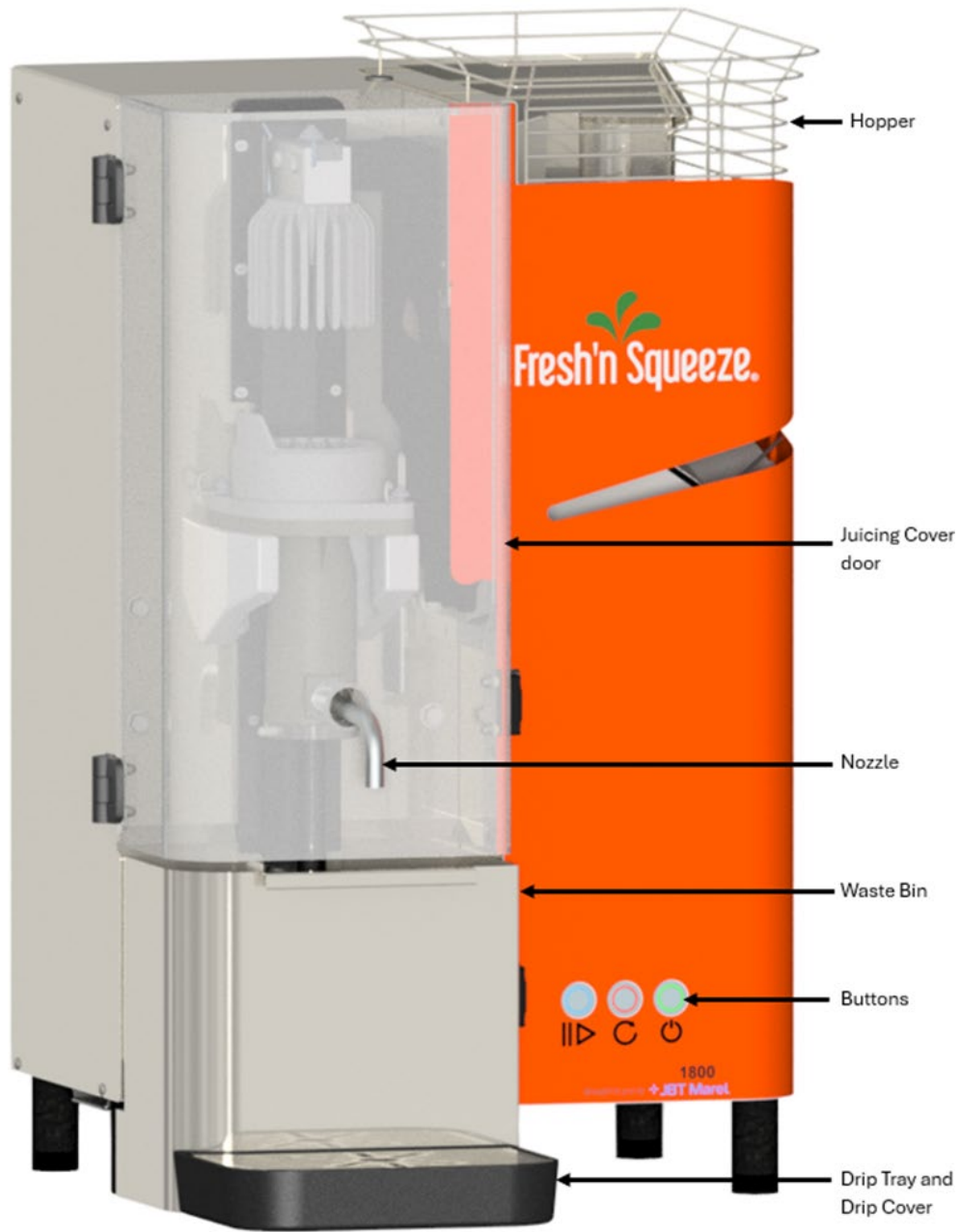

Figure 1a. FNS-1800 Juicer

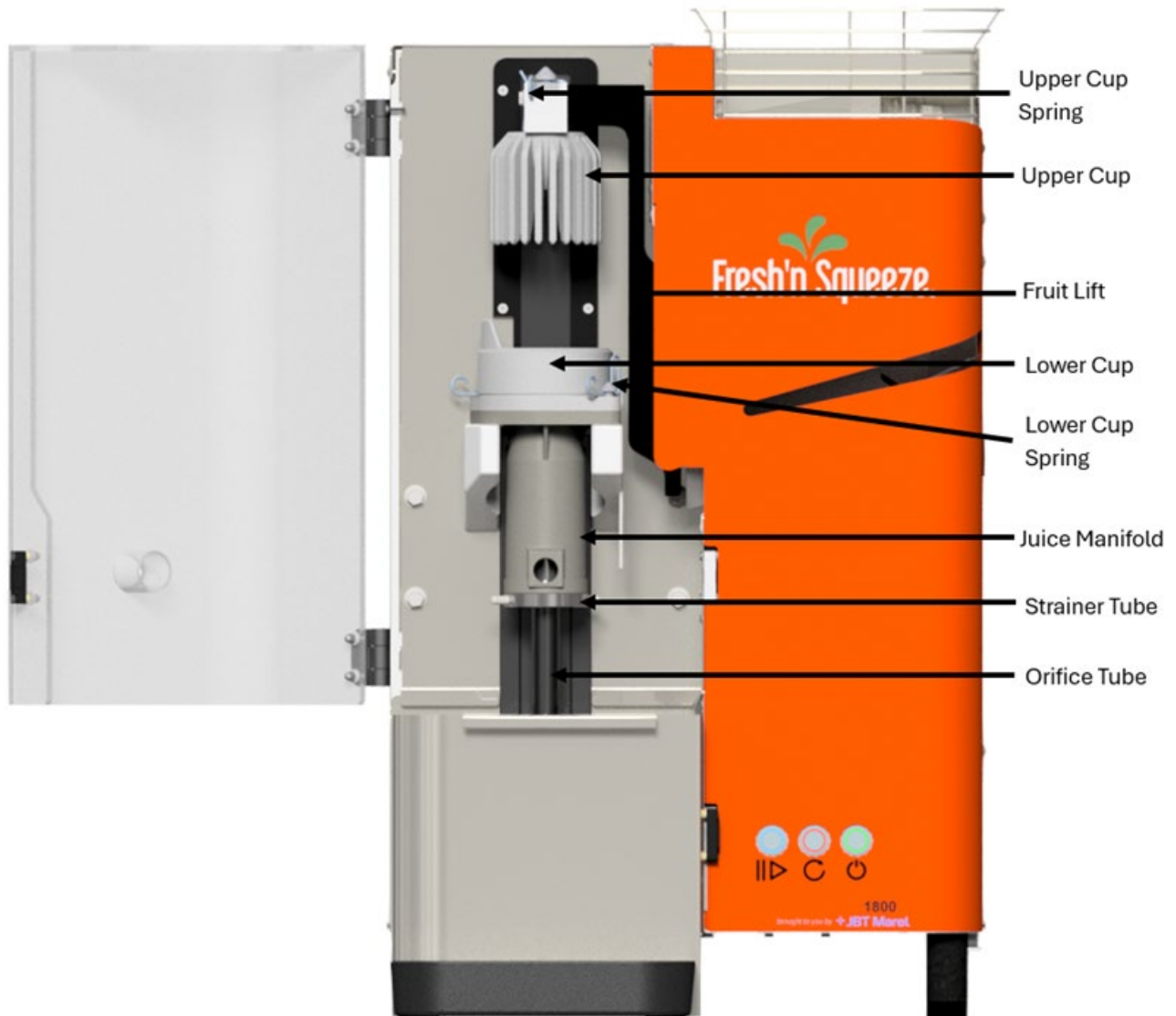
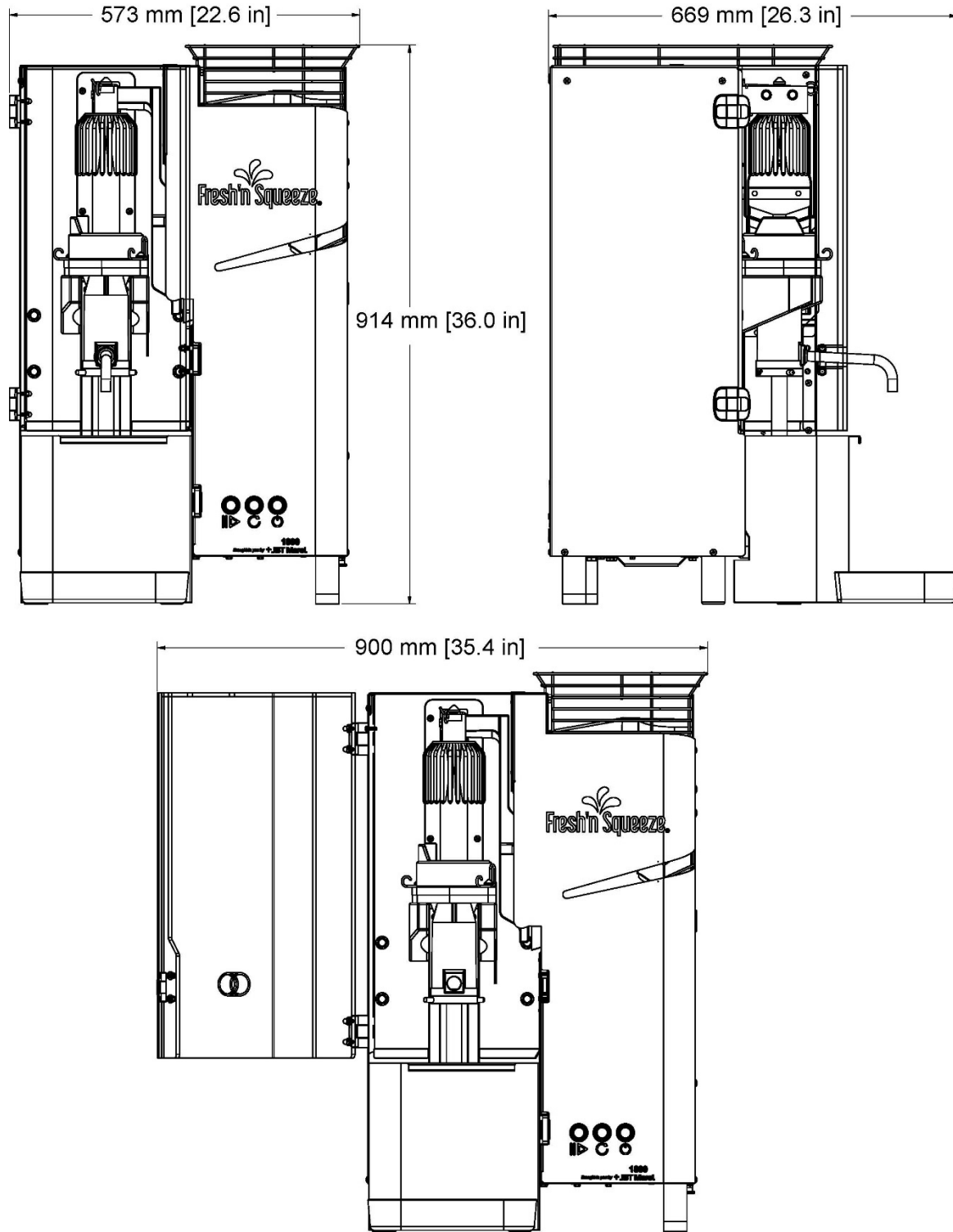

Figure 1b. Juicing Components Assembly



DOOR CLEARANCE

Figure 2. Dimensions

Operating Instructions

Equipment Check

Before plugging the FNS-1800 Juicer into an electrical outlet, the following steps must be performed:

1. **Locate the FNS-1800 Juicer on a level surface.**
This will prevent fruit feed problems.
2. **Check waste container.**
Make sure that waste container is in place.
3. **Check juicing components**
Open cover and check that juicing components are installed and securely fastened.
See **Figure 1b, page 9**.
4. **Close access cover.**
5. **Replace juice nozzle.**
6. **Make sure juice collector is in place.**
7. **Check the fruit feed chute or hopper for foreign objects.**
Remove any foreign objects found in the chute or hopper.
8. **Make sure floor area around FNS-1800 Juicer is clean and free of obstructions and water.**
When water is necessary, wear appropriate non-slip footwear.

Operating Instructions

Juicing

CAUTION: READ AND UNDERSTAND THE SAFETY AND OPERATING INSTRUCTIONS BEFORE OPERATING THE FNS-1800 JUICER.

1. **Turn on FNS-1800 Juicer.**
Push the green "ON-OFF" button to "ON" position.

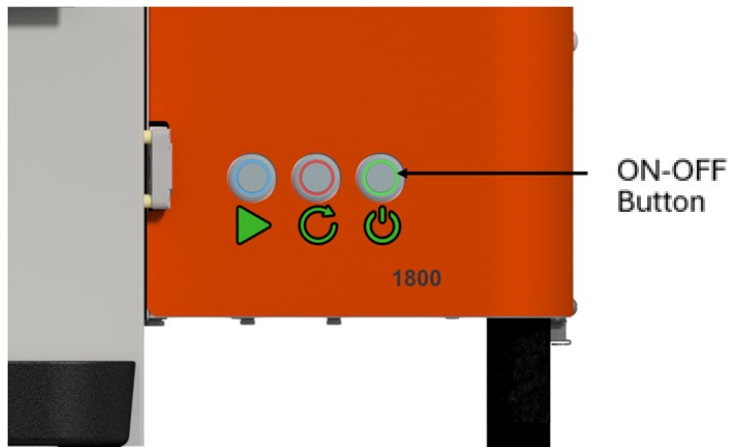

2. **Feed fruit into hopper of FNS-1800 Juicer.**
Dump approximately 1/3 carton (15 lbs.) of fruit into the hopper. Fruit may be divided between the carton and carton lid for ease of lifting.
3. **Run FNS-1800 Juicer.**
Push the blue "RUN" Switch.

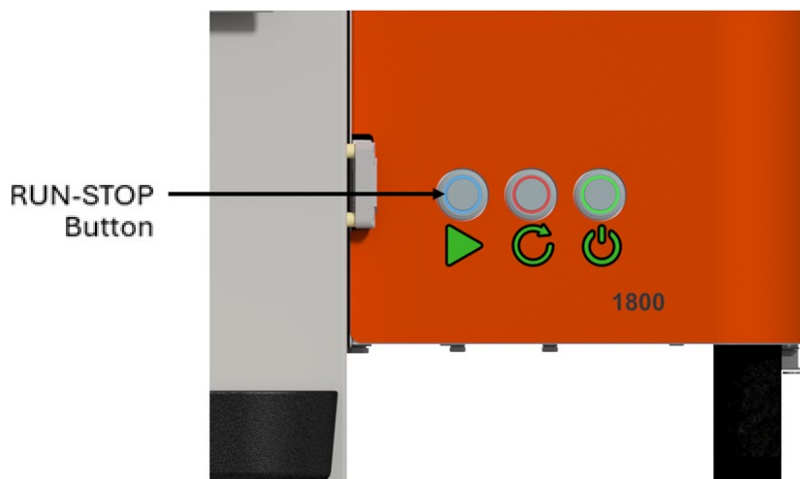

Operating Instructions

4. Dispense juice.

Fresh juice will separate.
Stir before dispensing.

5. Clear possible jams.

If machine stalls during operation, push the blue "RUN/STOP" button to the "STOP" position. Then press red "REVERSE" button to reverse direction of juicer and then continue to run.

IF YOU NEED TO CLEAR THE JAM, ALWAYS POWER OFF MACHINE AND REMOVE LOWER CUP FROM MACHINE TO CLEAR. DO NOT PLACE HANDS WHERE THE CUTTER IS LOCATED.

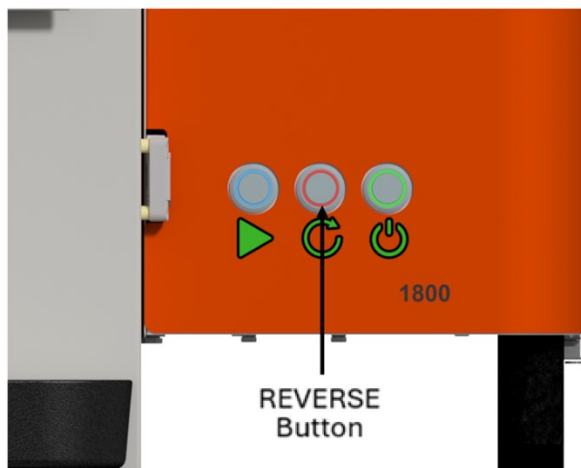

6. Clean FNS-1800 Juicer.

If finished juicing, clean FNS-1800 Juicer as soon as possible.
(See next page for cleaning instructions.)

Cleaning Instructions

ALWAYS follow cleaning and maintenance schedules in this manual to prevent equipment damage.

Clean FNS-1800 Juicer as soon as possible after juicing. Use a soft towel or sponge to wipe equipment parts. **DO NOT** use abrasive pads such as Scotch Brite®, steel wool, etc.

The recommended cleaner is JBT Marel Corporation brand CorKlean. CorKlean is a low-foaming alkaline equipment cleaner. It is safe on aluminum, 100% water soluble and free rinsing. CorKlean has been especially formulated for cleaning food processing equipment. Follow instructions on cleaner label for dilution.

NEVER use chlorine based cleaners on equipment.

1. Turn off FNS-1800 Juicer with Juicing Component Cups separated and Upper Arm in highest possible position.
2. DISCONNECT ELECTRICAL PLUG.

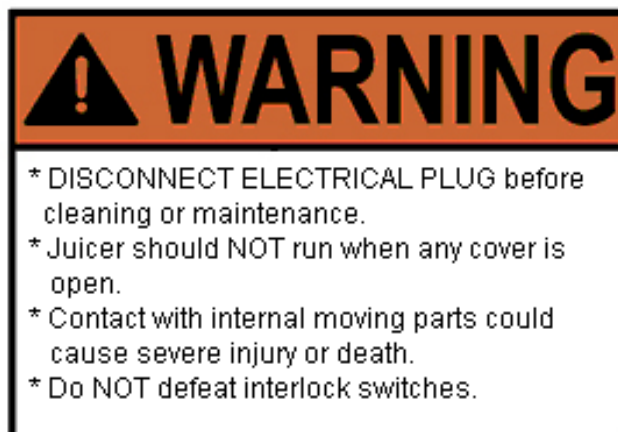

3. Brush all loose peel into waste container or bag.
4. Empty and rinse waste container.
5. NOTE: Juicing Cover Door hinges can be lifted up and off to be able to remove the door and take to a sink to make cleaning easier.

Cleaning Instructions

CAUTION: ALWAYS REMOVE POWER BEFORE CLEANING EQUIPMENT.

6. Remove Side Access Door.
Unclip and detach Safety Sensor from machine.

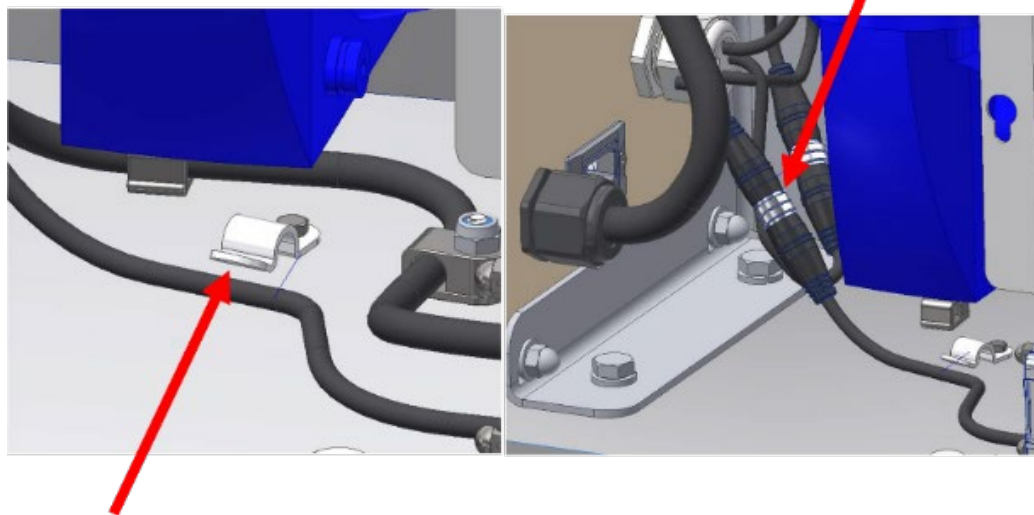

Cleaning Instructions

7. Remove Juicing Cover Door by lifting up on hinges.



8. Remove the top (4) phillips-head screws and loosen the bottom (3) phillips-head screws that are securing the Rear Cover. Lift the Rear Cover up and away for access to the machine.



Cleaning Instructions

9. Brush away any peel residue built up on the back of machine.
Using Corklean solution, wipe off any residue built up on back of machine.
NEVER USE ANY CHLORINE-BASED CLEANERS ON THIS MACHINE.

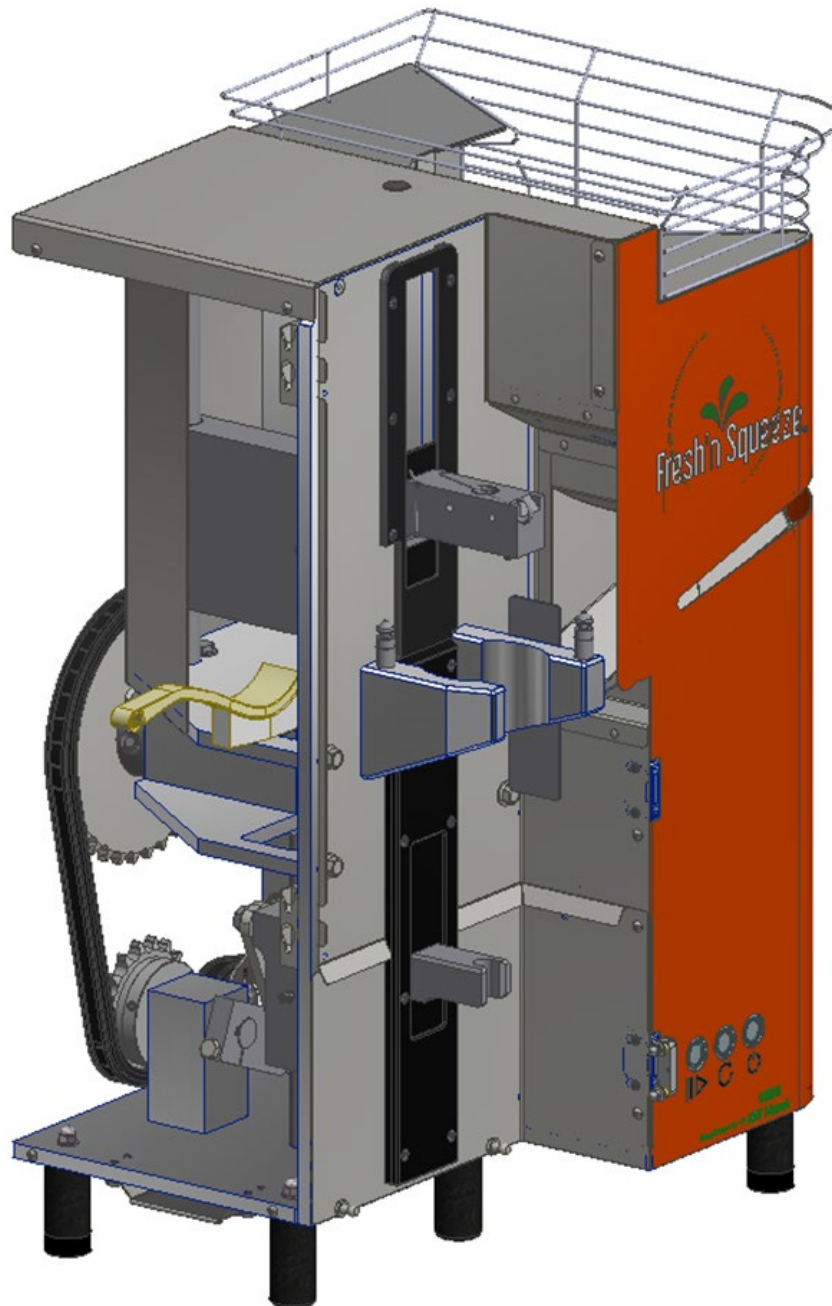

Cleaning Instructions

10. Remove juicing components.

- a. Cups should be separated. (FNS-1800 Juicer should be operated a couple cycles just before disassembly and have been turned off with cups in the separated position.)
- b. Grasp upper cup and release by flexing spring. Place upper cup in soaking container.

CAUTION: DO NOT PLACE HANDS OR FINGERS BETWEEN CUPS.

- c. Remove lower cup by squeezing spring and lifting up. Place lower cup in soaking container.

CAUTION: CUTTER AND KNIVES ARE SHARP.

- d. Install red protective cap on cutter. (Red protective cap is provided.)
 - e. Loosen strainer tube prior to removing manifold.
 - f. Grasp juice manifold and orifice tube firmly. Remove entire juicing components assembly.
 - g. Grasp orifice tube and pull out of strainer tube. If orifice tube cannot be removed, re-assemble to juicer, with lower cup in place, and operate a couple of cycles.
 - g. Remove strainer tube from inside juice manifold by turning tube counter-clockwise and sliding out. Place juicing components into soaking container.
- 11. Prepare cleaning solution.**
JBT Marel Corporation brand CorKlean is recommended. Read product label. Follow the manufacturer's mixing directions and safety precautions.
- 12. Immerse all components in cleaning solution.**
Prior to immersing use the blunt end of plastic rod provided to displace any fruit material lodged in the bore of the orifice tube.
Use pointed end of plastic rod to displace any fruit material lodged in cup fingers.

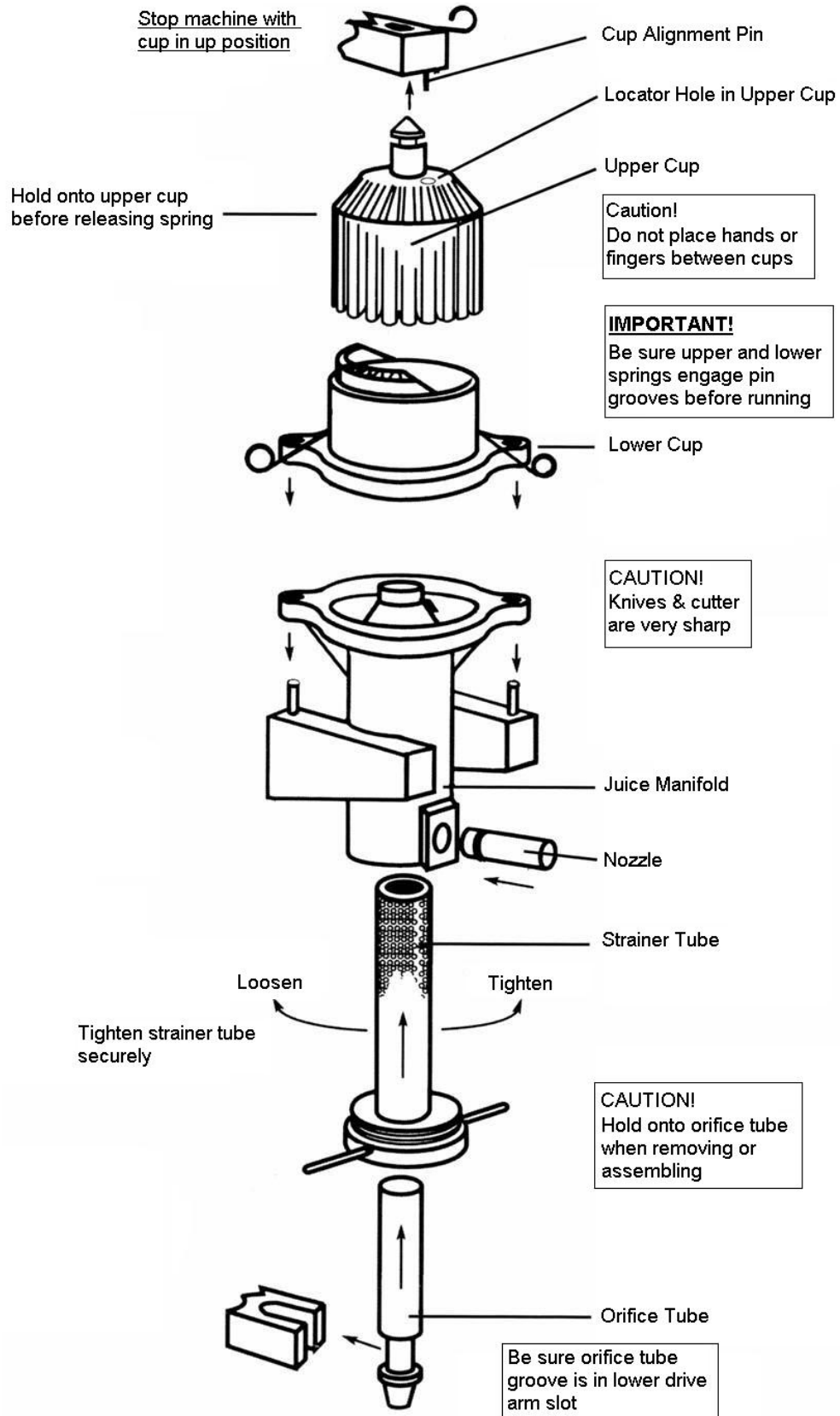

Figure 3. Juicing Components

Cleaning Instructions

- 13. Scrub components.**
Use a brush, towel, or sponge. **DO NOT** use abrasive pads such as Scotch Brite®, steel wool, etc. Thoroughly rinse with clean water, then thoroughly rinse with sanitizer solution. Follow the manufacturer's mixing directions and safety precautions. As an alternate cleaning method, all juicing components can be put in a dishwasher. If this method is used, components should be washed in CorKlean at least once a week. **DO NOT** soak aluminum cups longer than 30 min. Then, rinse and sanitize.
- 14. For best results, soak strainer tube in CorKlean overnight.**
After soaking overnight, rinse the strainer tube thoroughly before using. Check that all strainer tube holes are clean. Clean strainer tube with strainer tube brush tube. **Rinse thoroughly with sanitizer solution. Allow to air dry.**
- 15. If possible, hose down juicing area, cover and hopper.**
If location prohibits using a hose to clean juicing area and cover, ensure waste container is in place. Wash down the exposed juicing area and cover with a sponge or spray applicator using the recommended cleaning solution. Cover may be rinsed in place. Allow to stand for two minutes before rinsing thoroughly with water. Wipe down hopper area, fruit ramp area and fruit lift.
- 16. Re-assemble juicing components.**
Start by re-assembling strainer tube into juice manifold, and tightening. Insert orifice tube into bottom of strainer tube. Mount juice manifold assembly onto locating pins with orifice tube notch engaging lower drive. Remove red protective cap from cutter. Install lower cup and be sure spring snaps into pin grooves. **Install upper cup by slipping pin into stem hole, and turning until alignment pin engages cup. Be sure spring engages.**
- 17. Remove wax build-up as needed. (1 tablespoon of ammonia in 32 oz. spray bottle)**
Cups, feed chute, and other parts may acquire a build-up of wax overtime.

 - a. Soak cups for five minutes in an ammonia cleaning solution. Rinse thoroughly with sanitizer solution.
 - b. Wipe feed chute and other parts with a cloth soaked in ammonia cleaning solution. Rinse thoroughly with sanitizer solution.
- 18. Remove orange discoloration as needed.**
Equipment may exhibit some build-up or orange coloration over time. Wipe with a cloth soaked in CorKlean solution. Rinse thoroughly with sanitizer solution.

Maintenance

Before performing any maintenance, DISCONNECT ELECTRICAL PLUG.

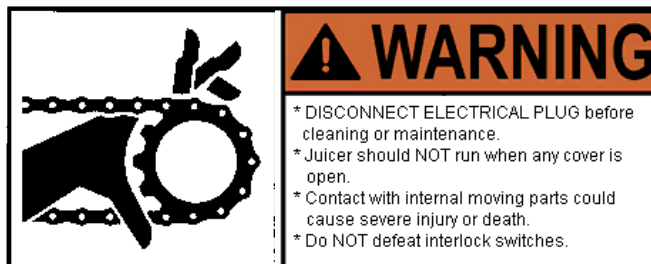

After every juice run:

1. Check cutter and knives for sharpness.

CAUTION: CUTTER AND KNIVES ARE SHARP.

Refer to **Figure 4** to determine condition of cutter.
If dull, sharpen with a whetstone.

Refer to **Figure 5a.** to sharpen cutter.

If cutter is severely damaged or rolled over, replace cutter.

a. **Cutter removal:**

Disassemble juicing components per **Figure 3, page 19**. Install red protective cap provided onto cutter. After red protective cap is installed, remove cutter. Handle cutter with care to avoid direct contact with sharp edge. Loosen set screw under front knife (make sure screw is backed out far enough to clear cutter). Cutter should lift out. If not, tap the cutter lightly from inside the juice manifold with 1-1/4" dia. rod (hammer handle).

b. **Cutter installation.**

Align arrows on cutter and juice manifold to seat cutter. Make sure cutter is fully seated. Tighten setscrew. **DO NOT** over tighten.

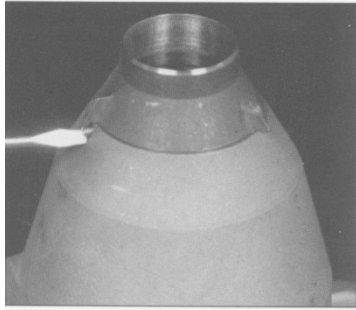

Figure 4. Installation of good cutter

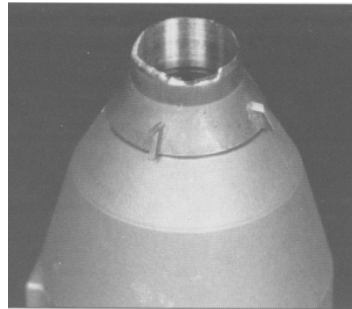

Figure 5a. Bad cutter- REPLACE cutter

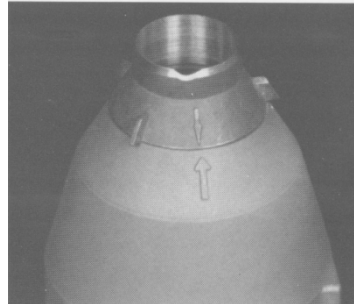

Figure 5b. Cutter that can be sharpened

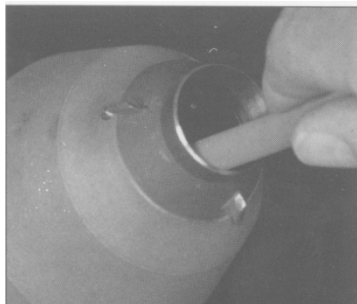

Figure 6a. Sharpening Cutter with Whetstone

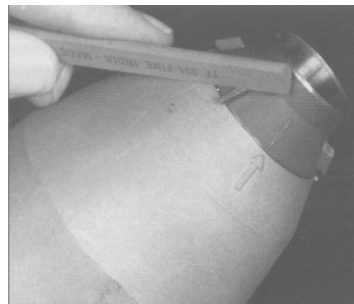

Figure 6b. Sharpening knife with Whetstone

Maintenance

2. **Check orifice tube for damage.**
Refer to Figure 7.

Replace tube when:

- a. Chunks are missing from top end.
- b. Score marks $1/32$ " or deeper appear along the length of the tube.

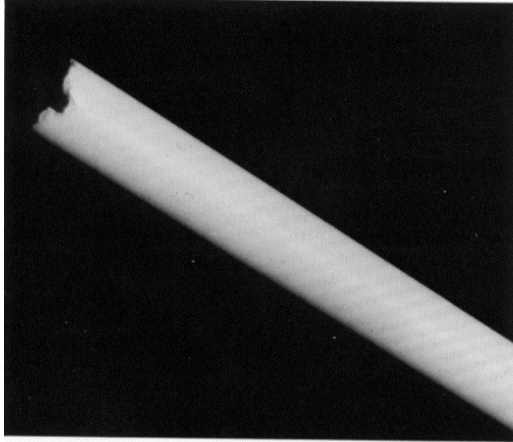

Figure 7. Severely Damaged Orifice Tube

3. **Check for loose or missing nuts and bolts.**
 - a. **Tighten or replace nuts and bolts as necessary.**
 - b. **DO NOT** exceed recommended torque ranges.
 - c. **ALWAYS** use JBT Marel Corporation recommended spare parts.

Periodic Inspection

Perform the following steps after every 3-4 months.

1. Test all interlock switches.

The FNS-1800 Juicer should stop automatically when juicing cover is opened, the waste container is not in place, or the access door is not in place. If FNS-1800 Juicer continues to run when any of these are open, the interlock switch is defective.

Stop the FNS-1800 Juicer and replace immediately.

2. Check all fasteners for tightness.

Remove back cover screws with phillips head screwdriver.

Check especially on the Sprockets, Crank Arms, Fruit Lift and Hopper.

3. Check chain for tightness.

Chain should have 1/4" maximum slack on top side. To adjust, loosen positioning nut and coupling nut on tensioner. Raise tensioner to required height using tensioner bolt. Lock tensioner in place by tightening positioning nut first, then the coupling nut second..

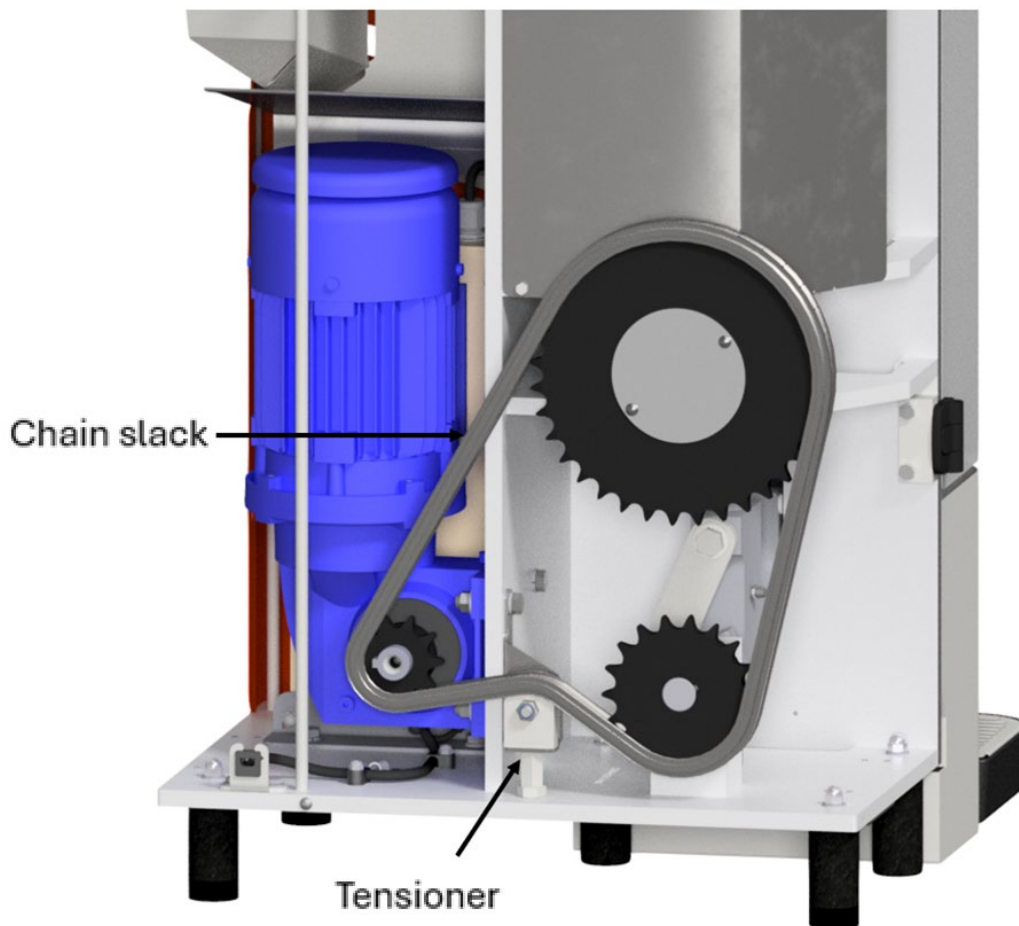

Periodic Inspection

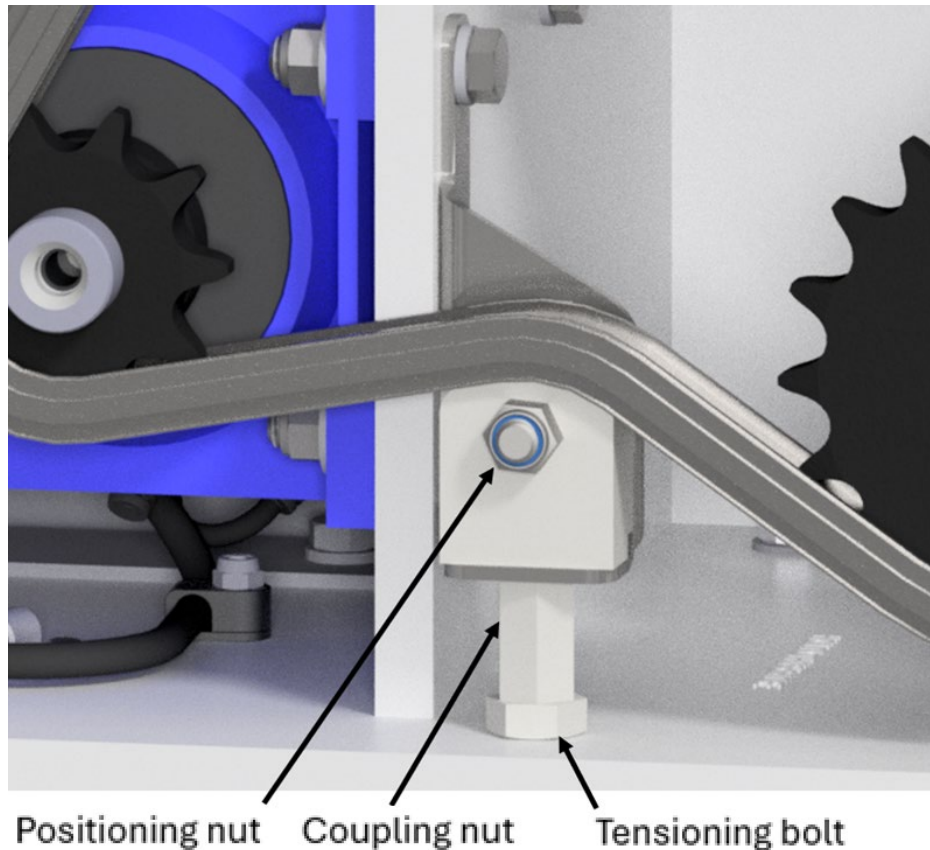

CAUTION: DO NOT OVERTIGHTEN CHAIN.

4. **Check chain and sprockets for rust.**
If rust appears, coat chain and sprockets with a small amount of Teflon grease.

For chain lubrication, JBT Marel recommends Food-Grade Chain Lube (p/n [575054](#)).
5. The FNS-1800 Juicer has moving assemblies that are fitted with grease fittings. These assemblies are NOT meant to be greased. The fittings were added to gain additional life out of the bearings once the bearings begin to reach the end of life. The bearings are not manufactured to be ran with grease.

Troubleshooting-Operator

**CAUTION: NEVER REACH INTO MOVING PARTS TO CLEAR A JAM,
NO MATTER HOW SIMPLE IT SEEMS.**

FNS-1800 Juicer will not start.

1. FNS-1800 Juicer is not plugged into electrical outlet or on/off switch is not in ON position.
2. Building, VFD or GFCI circuit breaker has tripped.
3. Juicing area door not closed.
4. FNS-1800 Juicer is jammed. Press reverse switch (middle red switch) to reverse the direction of cups and unjam the machine.
If not successful, call for service.
5. ON-OFF or RUN-STOP switch is defective.
Call for service.
6. One or more covers have a defective interlock switch.
Turn off FNS-1800 Juicer. Call for service.
7. Overloaded circuit.
FNS-1800 Juicer needs to be on separate (own) electrical outlet.
8. Low voltage to machine.
Use 110 volts minimum.

FNS-1800 Juicer starts, but shuts off.

1. Building circuit breaker is not properly rated or GFCI is tripping the VFD. Move to standard outlet or replace GFCI outlet with Legrand 2097TRAPLW or 1597TRAPLW outlet.
2. Extension cord or wiring is too long.
**Shorten extension cord or use heavier gauge wire.
(See page 6, "Electrical Specifications")**
3. All covers are not completely closed.
Close any open covers.

FNS-1800 Juicer runs with covers open or off.

1. Turn off FNS-1800 Juicer. Call for service.

Troubleshooting-Operator

FNS-1800 Juicer stalls trying to squeeze a fruit.

1. Fruit has part of stem on it.
Turn off FNS-1800 Juicer. Remove fruit from FNS-1800 Juicer and restart.
2. Peel is too thick.
Turn off FNS-1800 Juicer. Remove fruit from FNS-1800 Juicer and restart.
3. Cutter is damaged.
Sharpen or replace cutter as specified on page 22.

FNS-1800 Juicer emits a "squealing" sound during operation.

1. Turn off FNS-1800 Juicer. Call for service.

Low Juice Yield.

Excessive juice splattering during juicing operation.

1. Fruit is rotten or fruit stems are pulled.
Remove unsuitable fruit.
2. Orifice tube is damaged.
See page 23 to determine if it needs replacement.
3. Strainer tube is plugged.
Inspect strainer tube, clean if necessary. See page 19.
4. Double and triple feeds occurring.
Ensure fruit is properly sized.
5. O-ring on nozzle is damaged.
Replace o-ring.
6. Cutter is dull or damaged.
Sharpen or replace cutter.
7. Cups are dull or damaged.
Replace cups.

Troubleshooting-Operator

Fruit is being chopped instead of juiced.

1. Fruit is too large for FNS-1800 Juicer.
Turn off FNS-1800 Juicer. Remove oversized fruit. Maximum diameter is 3-1/4".
2. Fruit feeder is sticky or unclean.
**Turn off FNS-1800 Juicer. Remove fruit.
Clean fruit lift.**
3. FNS-1800 Juicer not level. Locate FNS-1800 Juicer on level surface.

Fruit is fed two at a time.

1. Fruit is too small for FNS-1800 Juicer.
Turn off FNS-1800 Juicer. Remove undersized fruit. Minimum diameter is 2-1/2".

Fruit is not fed during every cycle.

1. The hopper mechanism is designed to put fruit into a single file and to break-up bridging before feeding. When hopper is full, it sometimes takes a couple of cycles to begin feeding. Large or out of round fruit sometimes do not feed well.

Cutter is constantly being damaged.

1. Red protective cap is not being placed on cutter prior to removing juice manifold and during handling.
2. Juice manifold is not secure.

Be sure spring hold-downs on lower cup are properly engaged.

1. Cutter is not installed properly, ensure arrows are aligned and cutter is flush onto manifold. Ensure screw is properly torqued, do not over-tighten. See cutter installation instructions.
2. Upper cup is damaged. Inspect inside of upper cup for damage to upper cutter.

Illustrated Parts List

Assembly drawings in this chapter provide a list of part numbers for replaceable parts available for the FNS-1800 Juicer.

The parts listed in this *Operator Manual* include parts that the operator of the FNS-1800 Juicer should be able to replace without the help of a service technician.

For more detailed parts information on internal components that should be replaced by a qualified service technician, refer to the *Service Manual for the FNS-1800 Juicer*.

Parts List / Parts Drawing	Page
1. Juicing Components	30
2. Operator Replaceable Parts	31
3. Miscellaneous Parts and Tools	32

2. Operator Replaceable Parts

<u>Item</u>	<u>Qty</u>	<u>Part Number</u>	<u>Description</u>
1	1	060100854	DRIP PAN, PLASTIC, MOLDED,
2	1	060100841	DRIP COVER, 18 GA SS
3	1	060100839	FRUIT AGITATOR, HOPPER
4	1	060100831	FRUIT RAMP WELDMENT

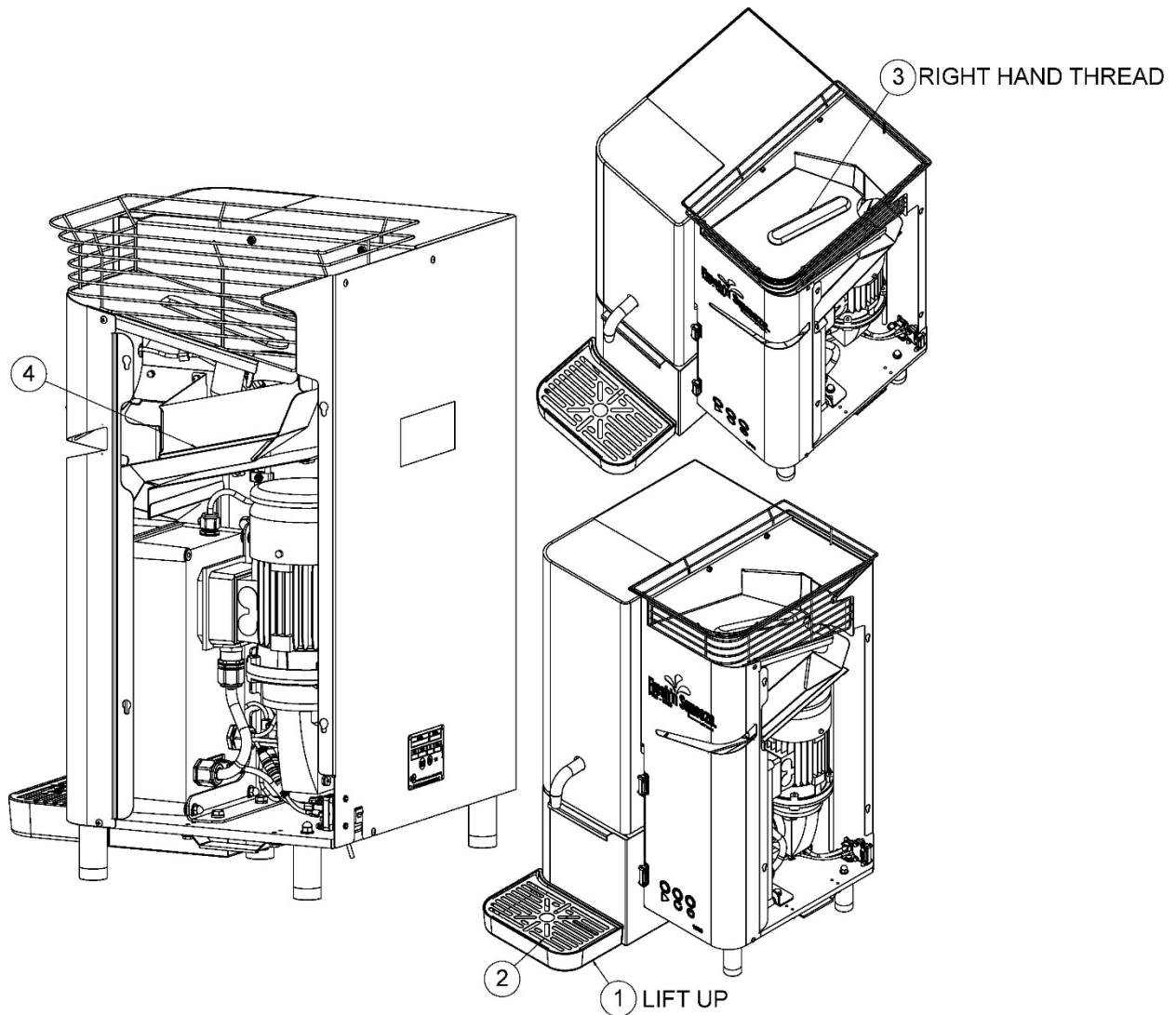

3. Miscellaneous Parts and Tools

<u>Item</u>	<u>Qty</u>	<u>Part Number</u>	<u>Description</u>
1	1	060100905	FRUIT SIZER, HAND-HELD
2	1	06000084	ROD, ORIFICE CLEAN OUT
3	1	009710031	STONE, SHARPENING, HALF RD, LOWER
4	1	009092018	CAP, COVER
5	1	009080328	BRUSH, TUBE, 1"
6	1	009080327	BRUSH, DISH

