

FNS-1800 Juicer

Service Manual



January 2026



FNS-1800 Juicer Service Manual

Copyright © JBT Marel Corporation 2026

JBT Marel Corporation
400 Fairway Avenue
Lakeland, FL 33801
(863) 683-5411

email: freshnsqueezeservice@jbt.com

Manual No. FNS-0015-060-EN

Safety Information	4
Safety Instructions	5
Technical Specifications	6
General Information	7
Operating Instructions	11
Cleaning Instructions	14
Maintenance	21
Periodic Inspection	24
Troubleshooting	26
Rebuilding	29
Illustrated Parts List	47

Important Safety Information

You can help prevent personal injury and/or property damage.

Please read this manual carefully before operating the FNS-1800 Juicer. DO NOT attempt any operation until understanding machine functions.

If uncertainty remains after studying this manual, please contact:

JBT Marel Corporation

400 Fairway Avenue
Lakeland, FL 33801
863.683.5411

email: freshnsqueezeservice@jbt.com

or

The local JBT Marel Corporation service representative in your country.

We're here to help. With proper handling, the Fresh 'n Squeeze FNS-1800 Juicer will provide safe, efficient and convenient service for years to come.

Revision History

Manual Code	Rev. No.	Date	Pages	Change History
FNS-0016-060-EN	A	1/8/2026	Entire manual	Initial release

Safety Labels

The safety labels shown below appear on the FNS-1800 Juicer. They provide essential instructions on how to avoid possible hazards.

Please, for your safety: FOLLOW THOSE INSTRUCTIONS AT ALL TIMES.

Should the FNS-1800 Juicer safety labels become damaged or unreadable, contact JBT Marel Corporation for replacement labels.

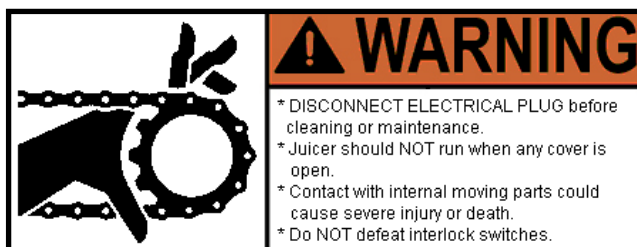

Safety Instructions

Carefully review the following safety instructions. Make them a habit when using the FNS-1800 Juicer.

1. If FNS-1800 Juicer continues to run when any access cover is open, interlock switch is defective.
Turn Juicer off and unplug immediately. Call for service.
2. **NEVER** attempt to make any safety device inoperative.
3. **NEVER** operate or perform maintenance or repair work on FNS-1800 Juicer when taking any kind of drug or sedative, when under the influence of alcohol, or when fatigued.
4. **ALWAYS** check adjustment of all nuts, bolts, and screws after installation, repair, or periodic maintenance.

Technical Specifications

Fruit Size: 2-1/2" to 3-1/4" major diameter
Oranges - FL: 125 to 80 count
Oranges - CA: 138 to 88 count
Lemons, Limes: 138 to 115 count
Holding capacity: 15 to 20 lbs. of fruit
Speed: 18 fruit/minute
Waste container capacity: 15 to 20 lbs.

Electrical Specifications

115V 60HZ Single Phase
or
230V 50HZ Single Phase

Shipping Specifications

Height: 36"
Width: 21"
Depth: 26"
Weight: 215 lbs.

General Information

The JBT Marel Corporation FNS-1800 Juicer is designed to provide years of dependable service. It uses a unique patented design to extract every available amount of juice from the fruit with the least amount of peel oil. The peel is completely separated from the juice and juice sacs before being compressed and strained.

The machine will juice oranges, lemons, limes, tangerines, etc., without changing or adjusting parts. In fact, different varieties of fruit can be juiced to create various fruit juice blends.

Clean up is simple, requiring disassembly of only five parts. All waste material - peel, membranes, and seeds - is collected for easy removal and disposal.

The FNS-1800 Juicer is solidly built using heavy-duty components in all assemblies, including the drive. It is simple to operate and uses a minimal number of parts.

ALWAYS follow cleaning and maintenance schedules in this manual to prevent equipment damage.

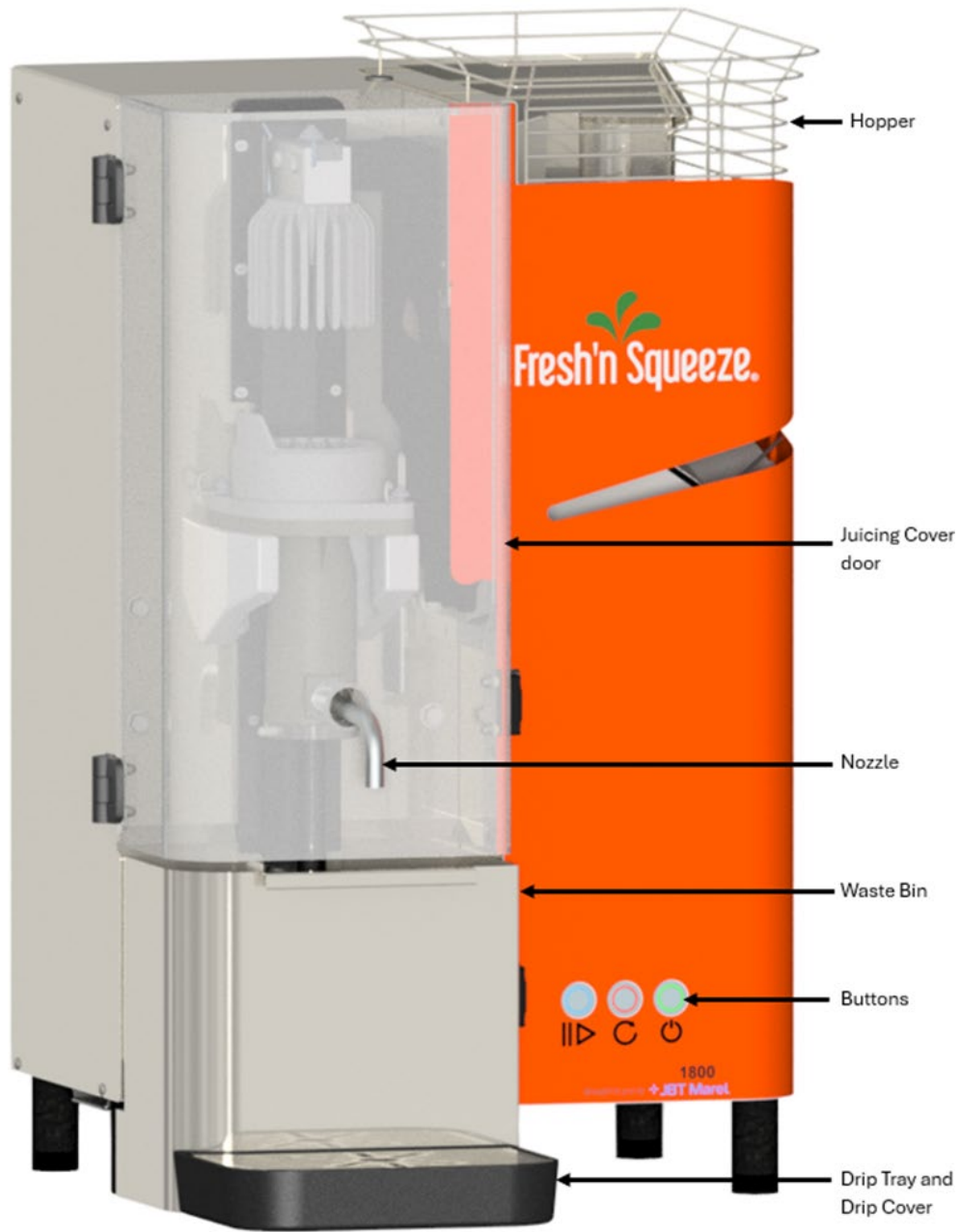

Figure 1a. FNS-1800 Juicer

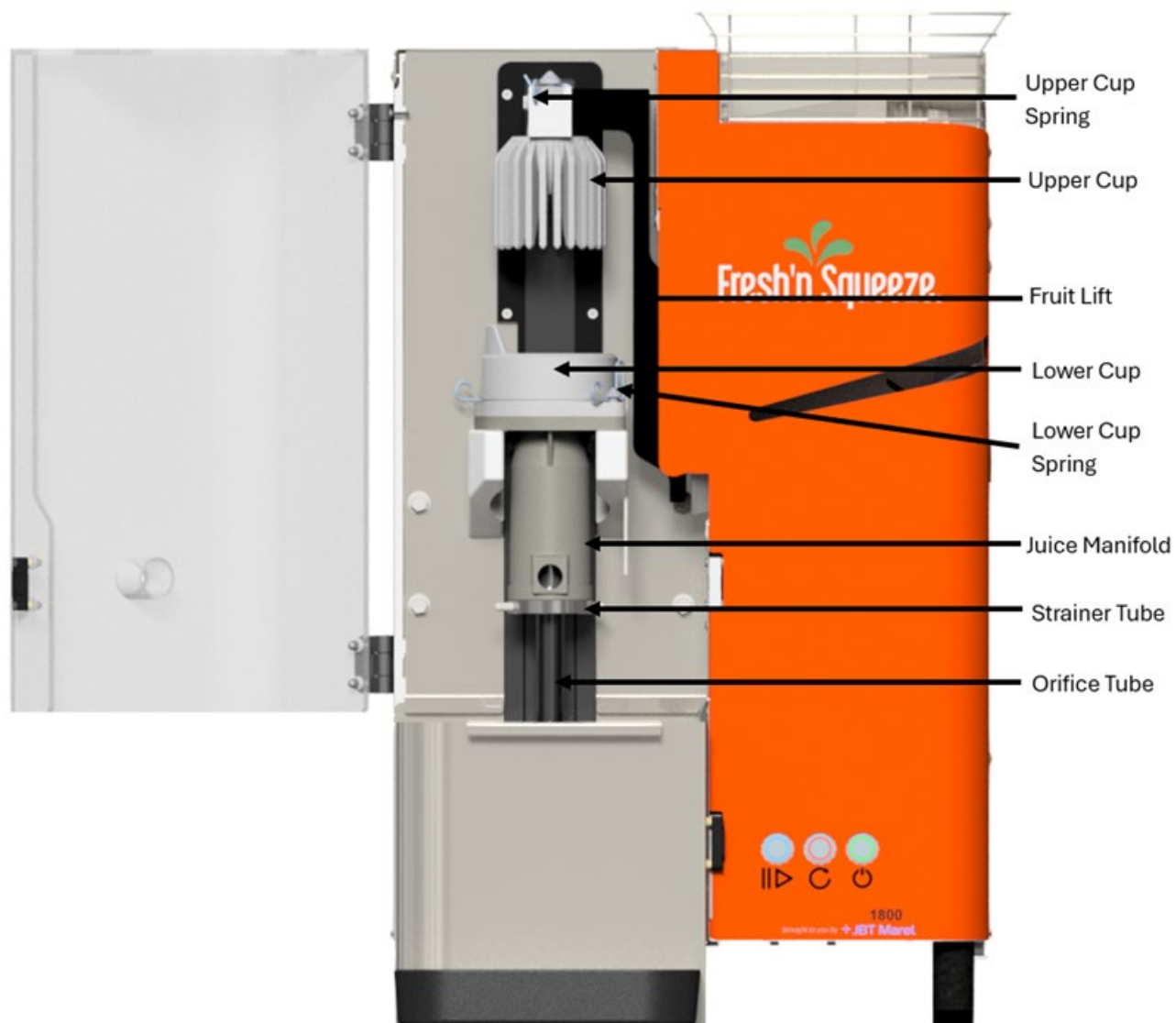
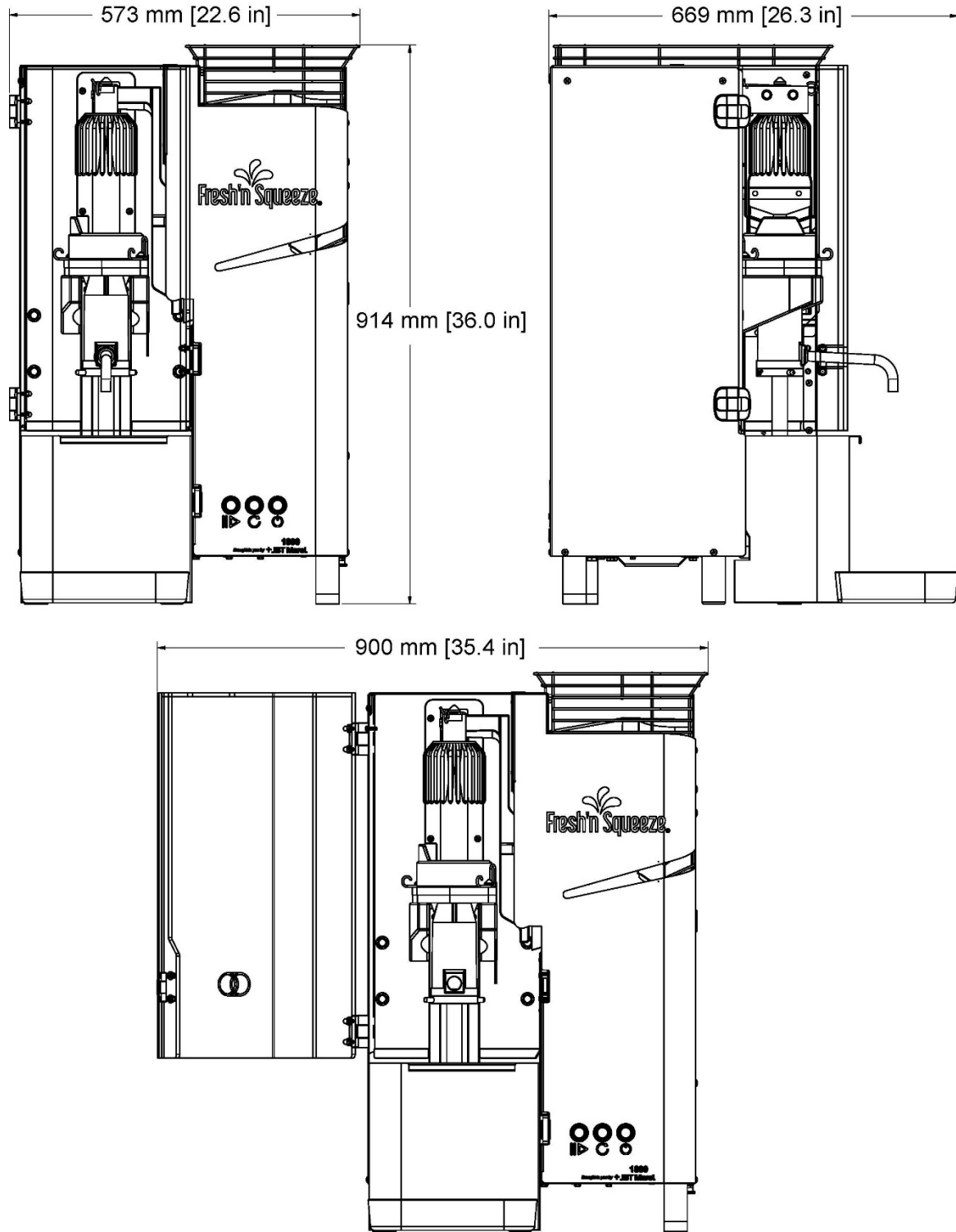

Figure 1b. Juicing Components Assembly



DOOR CLEARANCE

Figure 2. Dimensions

Operating Instructions

Equipment Check

Before plugging the FNS-1800 Juicer into an electrical outlet, the following steps must be performed:

1. **Locate the FNS-1800 Juicer on a level surface.**
This will prevent fruit feed problems.
2. **Check waste container.**
Make sure that waste container is in place.
3. **Check juicing components**
Open cover and check that juicing components are installed and securely fastened.
See **Figure 1b, page 9**.
4. **Close access cover.**
5. **Replace juice nozzle.**
6. **Make sure juice collector is in place.**
7. **Check the fruit feed chute or hopper for foreign objects.**
Remove any foreign objects found in the chute or hopper.
8. **Make sure floor area around FNS-1800 Juicer is clean and free of obstructions and water.**
When water is necessary, wear appropriate non-slip footwear.

Operating Instructions

Juicing

CAUTION: READ AND UNDERSTAND THE SAFETY AND OPERATING INSTRUCTIONS BEFORE OPERATING THE FNS-1800 JUICER.

1. **Turn on FNS-1800 Juicer.**
Push the green "ON-OFF" button to "ON" position.

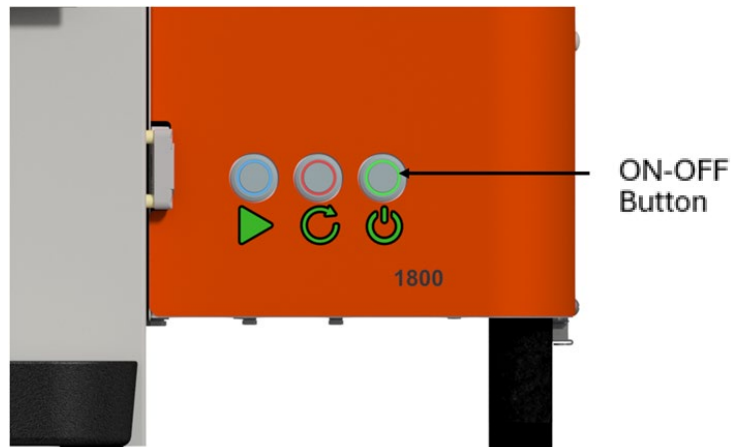

2. **Feed fruit into hopper of FNS-1800 Juicer.**
Dump approximately 1/3 carton (15 lbs.) of fruit into the hopper. Fruit may be divided between the carton and carton lid for ease of lifting.

3. **Run FNS-1800 Juicer.**
Push the blue "RUN" Switch.

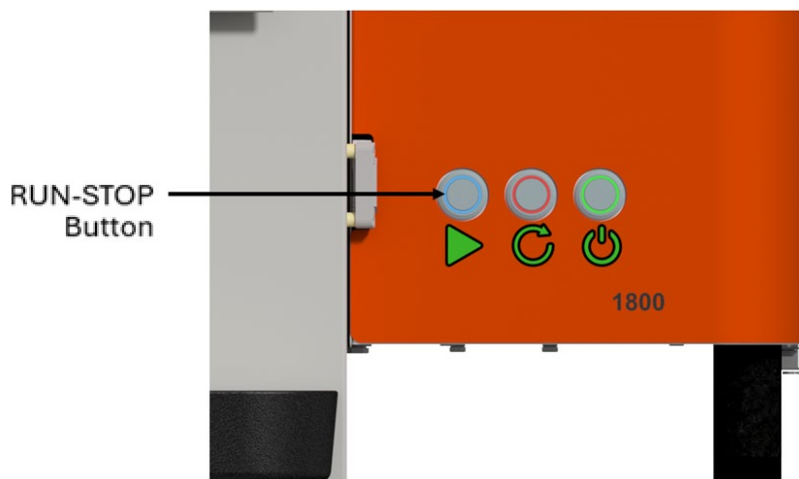

Operating Instructions

4. Dispense juice.

Fresh juice will separate.
Stir before dispensing.

5. Clear possible jams.

If machine stalls during operation, push the blue "RUN/STOP" button to the "STOP" position. Then press red "REVERSE" button to reverse direction of juicer and then continue to run.

IF YOU NEED TO CLEAR THE JAM, ALWAYS POWER OFF MACHINE AND REMOVE LOWER CUP FROM MACHINE TO CLEAR. DO NOT PLACE HANDS WHERE THE CUTTER IS LOCATED.

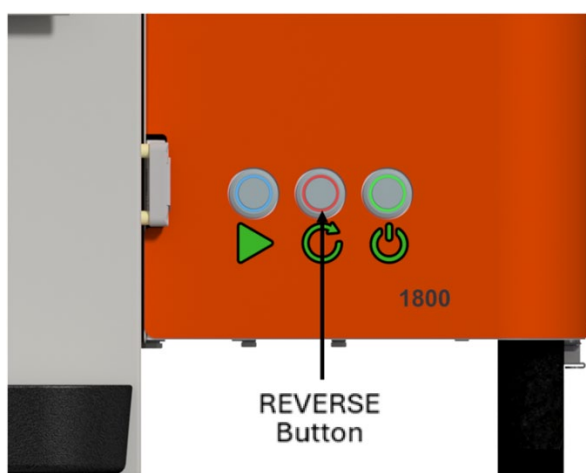

6. Clean FNS-1800 Juicer.

If finished juicing, clean FNS-1800 Juicer as soon as possible.
(See next page for cleaning instructions.)

Cleaning Instructions

ALWAYS follow cleaning and maintenance schedules in this manual to prevent equipment damage.

Clean FNS-1800 Juicer as soon as possible after juicing. Use a soft towel or sponge to wipe equipment parts. **DO NOT** use abrasive pads such as Scotch Brite®, steel wool, etc.

The recommended cleaner is JBT Marel Corporation brand CorKlean. CorKlean is a low-foaming alkaline equipment cleaner. It is safe on aluminum, 100% water soluble and free rinsing. CorKlean has been especially formulated for cleaning food processing equipment. Follow instructions on cleaner label for dilution.

NEVER use chlorine based cleaners on equipment.

1. Turn off FNS-1800 Juicer with Juicing Component cups separated and Upper Arm in highest possible position.
2. DISCONNECT ELECTRICAL PLUG.

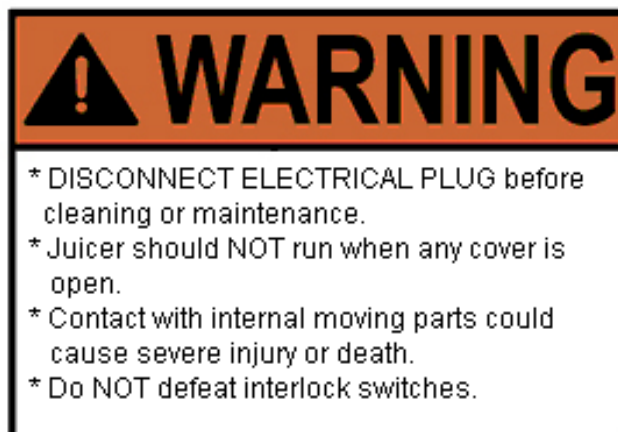

3. Brush all loose peel into waste container or bag.
4. Empty and rinse waste container.
5. NOTE: Juicing Cover Door hinges can be lifted up and off to be able to remove the door and take to a sink to make cleaning easier.

Cleaning Instructions

CAUTION: ALWAYS REMOVE POWER BEFORE CLEANING EQUIPMENT.

6. Remove Side Access Door.
Unclip and detach Safety Sensor from machine.

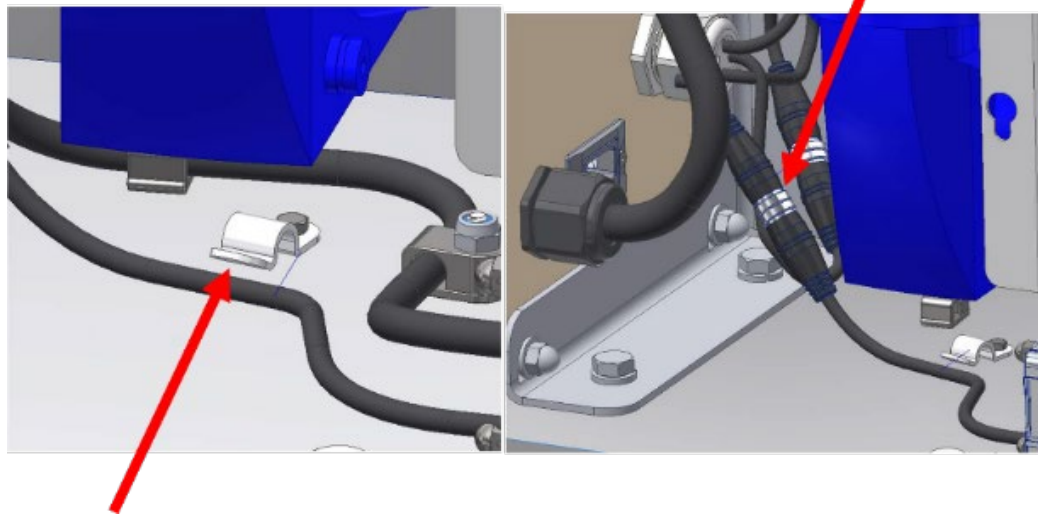

Cleaning Instructions

7. Remove Juicing Cover Door by lifting up on hinges.



8. Remove the top (4) phillips-head screws and loosen the bottom (3) phillips-head screws that are securing the Rear Cover. Lift the Rear Cover up and away for access to the machine.



Cleaning Instructions

9. Brush away any peel residue built up on the back of machine.
Using Corklean solution, wipe off any residue built up on back of machine.
NEVER USE ANY CHLORINE-BASED CLEANERS ON THIS MACHINE.

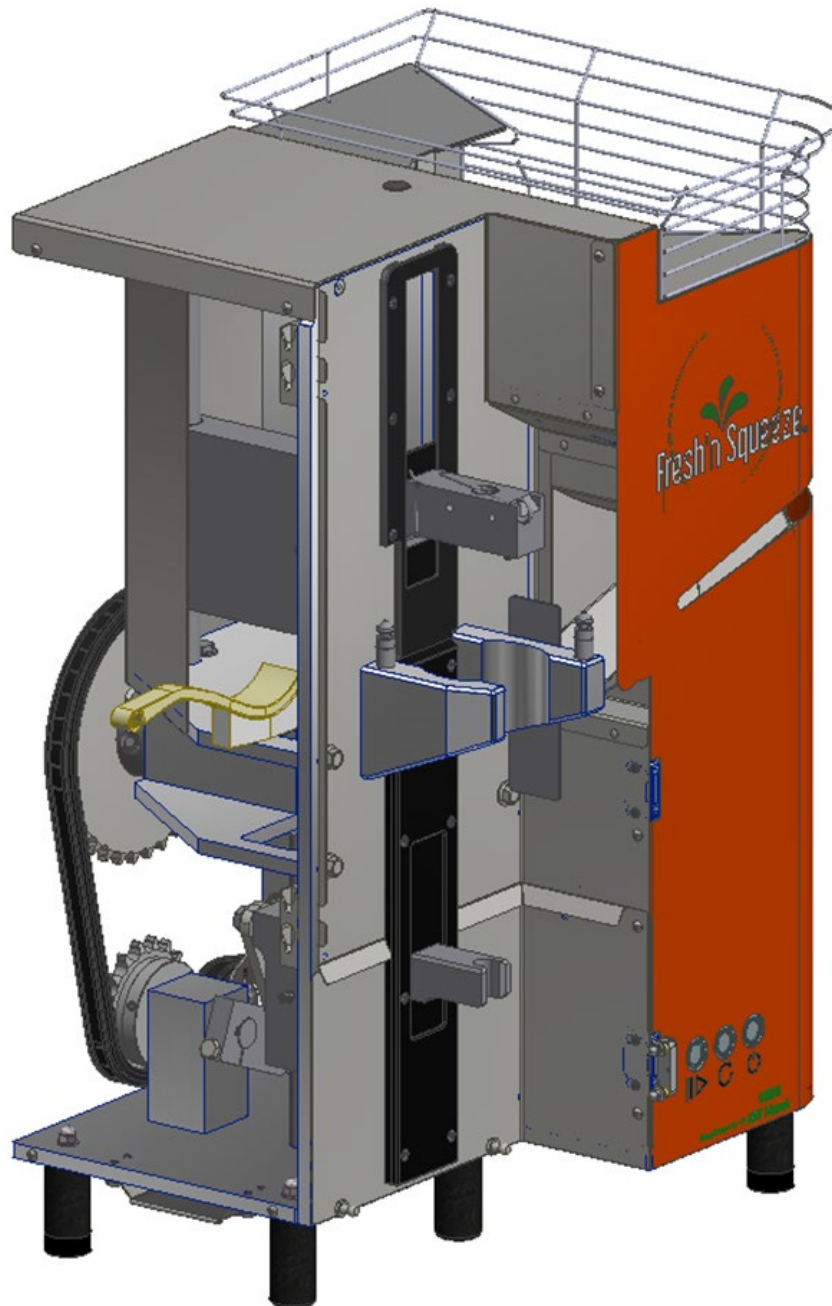

Cleaning Instructions

10. Remove juicing components.

- a. Cups should be separated. (FNS-1800 Juicer should be operated a couple cycles just before disassembly and have been turned off with cups in the separated position.)
- b. Grasp upper cup and release by flexing spring. Place upper cup in soaking container.

CAUTION: DO NOT PLACE HANDS OR FINGERS BETWEEN CUPS.

- c. Remove lower cup by squeezing spring and lifting up. Place lower cup in soaking container.

CAUTION: CUTTER AND KNIVES ARE SHARP.

- d. Install red protective cap on cutter. (Red protective cap is provided.)
 - e. Loosen strainer tube prior to removing manifold.
 - f. Grasp juice manifold and orifice tube firmly. Remove entire juicing components assembly.
 - g. Grasp orifice tube and pull out of strainer tube. If orifice tube cannot be removed, re-assemble to juicer, with lower cup in place, and operate a couple of cycles.
 - g. Remove strainer tube from inside juice manifold by turning tube counter-clockwise and sliding out. Place juicing components into soaking container.
- 11. Prepare cleaning solution.**
JBT Marel Corporation brand CorKlean is recommended. Read product label. Follow the manufacturer's mixing directions and safety precautions.
- 12. Immerse all components in cleaning solution.**
Prior to immersing use the blunt end of plastic rod provided to displace any fruit material lodged in the bore of the orifice tube.
Use pointed end of plastic rod to displace any fruit material lodged in cup fingers.

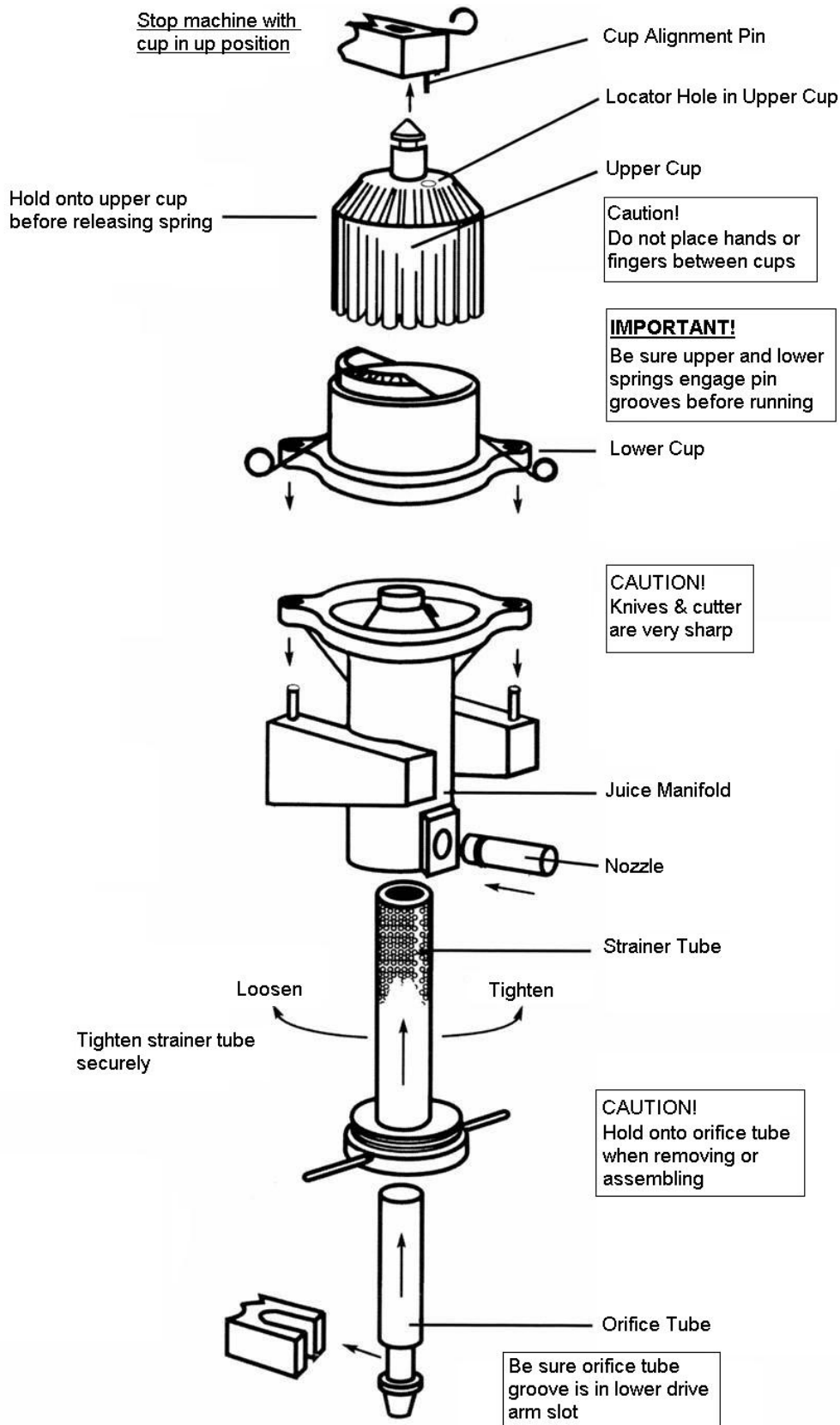

Figure 3. Juicing Components

Cleaning Instructions

13. Scrub components.

Use a brush, towel, or sponge. **DO NOT** use abrasive pads such as Scotch Brite®, steel wool, etc. Thoroughly rinse with clean water, then thoroughly rinse with sanitizer solution. Follow the manufacturer's mixing directions and safety precautions. As an alternate cleaning method, all juicing components can be put in a dishwasher. If this method is used, components should be washed in CorKlean at least once a week. **DO NOT** soak aluminum cups longer than 30 min. Then, rinse and sanitize.

14. For best results, soak strainer tube in CorKlean overnight.

After soaking overnight, rinse the strainer tube thoroughly before using. Check that all strainer tube holes are clean. Clean strainer tube with strainer tube brush tube. **Rinse thoroughly with sanitizer solution. Allow to air dry.**

15. If possible, hose down juicing area, cover and hopper.

If location prohibits using a hose to clean juicing area and cover, ensure waste container is in place. Wash down the exposed juicing area and cover with a sponge or spray applicator using the recommended cleaning solution. Cover may be rinsed in place. Allow to stand for two minutes before rinsing thoroughly with water. Wipe down hopper area, fruit ramp area and fruit lift.

16. Re-assemble juicing components.

Start by re-assembling strainer tube into juice manifold, and tightening. Insert orifice tube into bottom of strainer tube. Mount juice manifold assembly onto locating pins with orifice tube notch engaging lower drive. Remove red protective cap from cutter. Install lower cup and be sure spring snaps into pin grooves. **Install upper cup by slipping pin into stem hole, and turning until alignment pin engages cup. Be sure spring engages.**

17. Remove wax build-up as needed. (1 tablespoon of ammonia in 32 oz. spray bottle)
Cups, feed chute, and other parts may acquire a build-up of wax overtime.

- a. Soak cups for five minutes in an ammonia cleaning solution. Rinse thoroughly with sanitizer solution.
- b. Wipe feed chute and other parts with a cloth soaked in ammonia cleaning solution. Rinse thoroughly with sanitizer solution.

18. Remove orange discoloration as needed.

Equipment may exhibit some build-up or orange coloration over time. Wipe with a cloth soaked in CorKlean solution. Rinse thoroughly with sanitizer solution.

Maintenance

Before performing any maintenance, DISCONNECT ELECTRICAL PLUG.

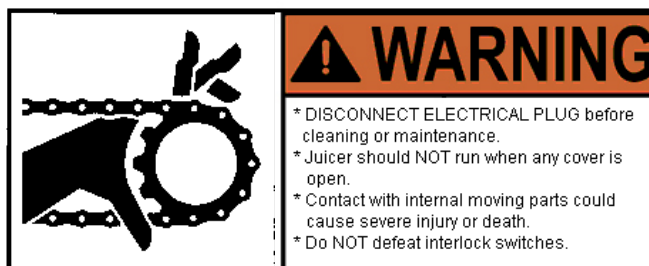

After every juice run:

1. Check cutter and knives for sharpness.

CAUTION: CUTTER AND KNIVES ARE SHARP.

Refer to **Figure 4** to determine condition of cutter.
If dull, sharpen with a whetstone.

Refer to **Figure 5a.** to sharpen cutter.

If cutter is severely damaged or rolled over, replace cutter.

a. **Cutter removal:**

Disassemble juicing components per **Figure 3, page 19**. Install red protective cap provided onto cutter. After red protective cap is installed, remove cutter. Handle cutter with care to avoid direct contact with sharp edge. Loosen set screw under front knife (make sure screw is backed out far enough to clear cutter). Cutter should lift out. If not, tap the cutter lightly from inside the juice manifold with 1-1/4" dia. rod (hammer handle).

b. **Cutter installation.**

Align arrows on cutter and juice manifold to seat cutter. Make sure cutter is fully seated. Tighten setscrew. **DO NOT** over tighten.

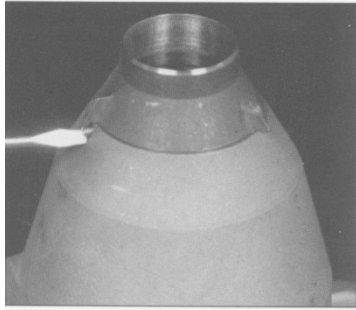

Figure 4. Installation of good cutter

Figure 5a. Bad cutter- REPLACE cutter

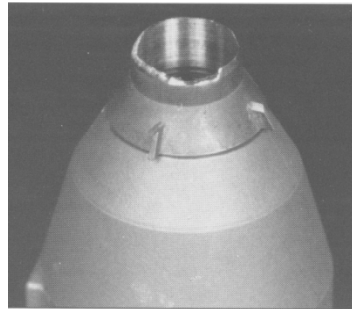

Figure 5b. Cutter that can be sharpened

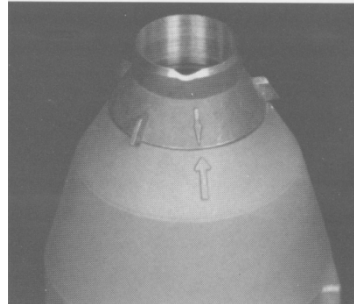

Figure 6a. Sharpening Cutter with Whetstone

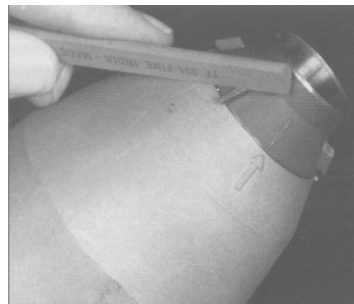

Figure 6b. Sharpening knife with Whetstone

Maintenance

2. **Check orifice tube for damage.**
Refer to Figure 7.

Replace tube when:

- a. Chunks are missing from top end.
- b. Score marks 1/32" or deeper appear along the length of the tube.

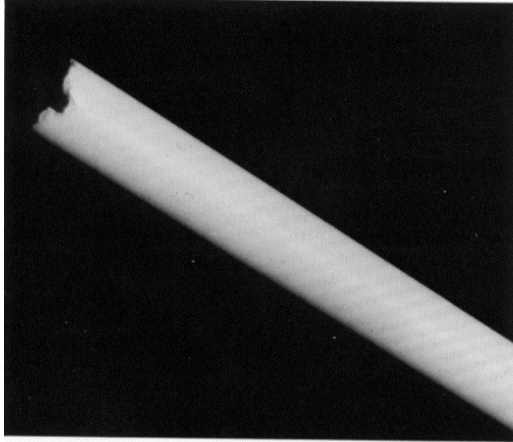

Figure 7. Severely Damaged Orifice Tube

3. **Check for loose or missing nuts and bolts.**
 - a. **Tighten or replace nuts and bolts as necessary.**
 - b. **DO NOT** exceed recommended torque ranges.
 - c. **ALWAYS** use JBT Marel Corporation recommended spare parts.

Periodic Inspection

Perform the following steps after every 3-4 months.

1. Test all interlock switches.

The FNS-1800 Juicer should stop automatically when juicing cover is opened, the waste container is not in place, or the access door is not in place. If FNS-1800 Juicer continues to run when any of these are open, the interlock switch is defective.

Stop the FNS-1800 Juicer and replace immediately.

2. Check all fasteners for tightness.

Remove back cover screws with phillips head screwdriver.

Check especially on the Sprockets, Crank Arms, Fruit Lift and Hopper.

3. Check chain for tightness.

Chain should have 1/4" maximum slack on top side. To adjust, loosen positioning nut and coupling nut on tensioner. Raise tensioner to required height using tensioner bolt. Lock tensioner in place by tightening positioning nut first, then the coupling nut second.

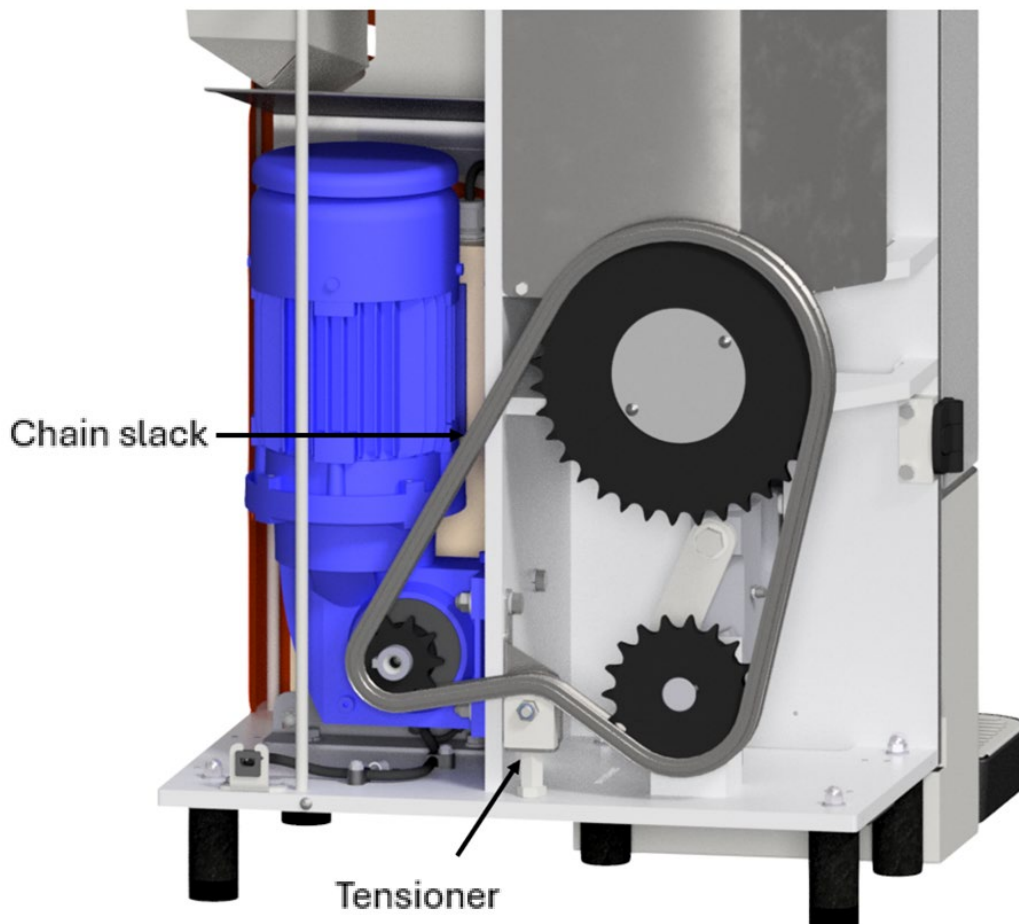

Periodic Inspection

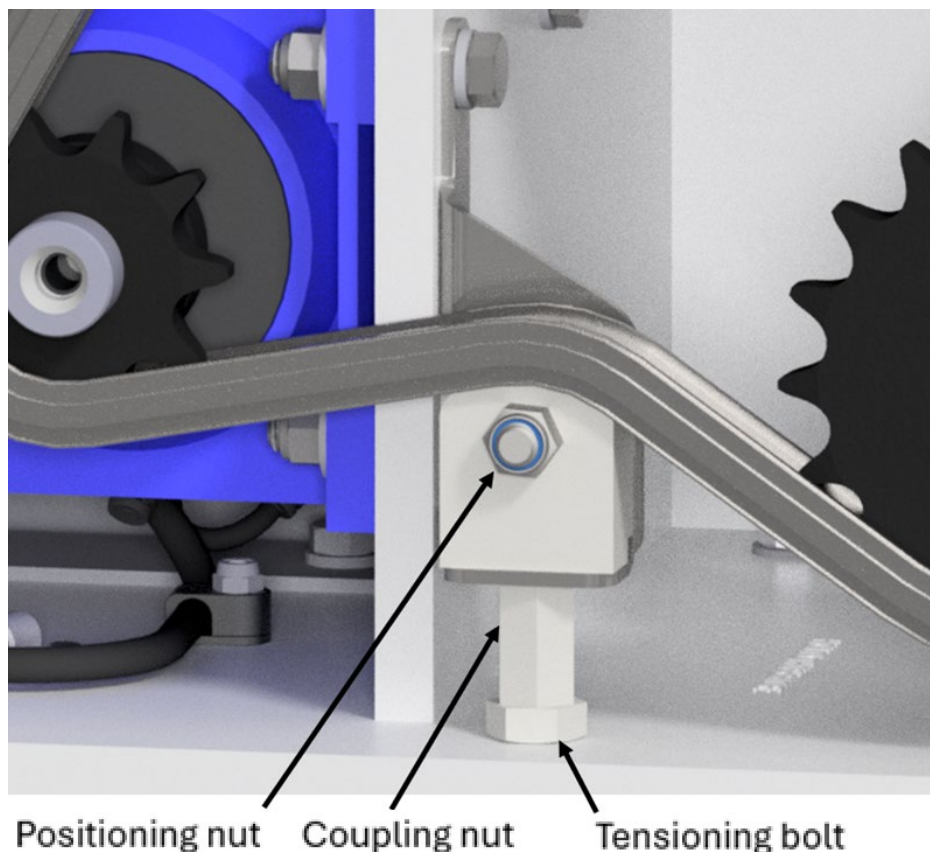

CAUTION: DO NOT OVERTIGHTEN CHAIN.

4. **Check chain and sprockets for rust.**
If rust appears, coat chain and sprockets with a small amount of Teflon grease.

For chain lubrication, JBT Marel recommends Food-Grade Chain Lube (p/n [575054](#)).
5. The FNS-1800 Juicer has moving assemblies that are fitted with grease fittings. These assemblies are NOT meant to be greased. The fittings were added to gain additional life out of the bearings once the bearings begin to reach end of life. The bearings are not manufactured to be ran with grease.

Troubleshooting

**CAUTION: NEVER REACH INTO MOVING PARTS TO CLEAR A JAM,
NO MATTER HOW SIMPLE IT SEEMS.**

FNS-1800 Juicer will not start.

1. FNS-1800 Juicer is not plugged into electrical outlet or on/off switch is not in ON position.
2. Building, VFD or GFCI circuit breaker has tripped.
3. Juicing area door not closed.
4. FNS-1800 Juicer is jammed. Press reverse switch (middle red switch) to reverse the direction of cups and unjam the machine.
If not successful, call for service.
5. ON-OFF or RUN-STOP switch is defective.
Call for service.
6. One or more covers have a defective interlock switch.
Turn off FNS-1800 Juicer. Call for service.
7. Overloaded circuit.
FNS-1800 Juicer needs to be on separate (own) electrical outlet.
8. Low voltage to machine.
Use 110 volts minimum.

FNS-1800 Juicer starts, but shuts off.

1. Building circuit breaker is not properly rated or GFCI is tripping the VFD. Move to standard outlet or replace GFCI outlet with *Legrand 2097TRAPLW* or *1597TRAPLW* outlet.
2. Extension cord or wiring is too long.
Shorten extension cord or use heavier gauge wire.
(See page 6, "Electrical Specifications")
3. All covers are not completely closed.
Close any open covers.

FNS-1800 Juicer runs with covers open or off.

1. Turn off FNS-1800 Juicer. Call for service.

Troubleshooting

FNS-1800 Juicer stalls trying to squeeze a fruit.

1. Fruit has part of stem on it.
Turn off FNS-1800 Juicer. Remove fruit from FNS-1800 Juicer and restart.
2. Peel is too thick.
Turn off FNS-1800 Juicer. Remove fruit from FNS-1800 Juicer and restart.
3. Cutter is damaged.
Sharpen or replace cutter as specified on page 22.

FNS-1800 Juicer emits a "squealing" sound during operation.

1. Turn off FNS-1800 Juicer. Call for service.

Low Juice Yield.

Excessive juice splattering during juicing operation.

1. Fruit is rotten or fruit stems are pulled.
Remove unsuitable fruit.
2. Orifice tube is damaged.
See page 18 to determine if it needs replacement.
3. Strainer tube is plugged.
Inspect strainer tube, clean if necessary. See page 23.
4. Double and triple feeds occurring.
Ensure fruit is properly sized.
5. O-ring on nozzle is damaged.
Replace O-ring.
6. Cutter is dull or damaged.
Sharpen or replace cutter.
7. Cups are dull or damaged.
Replace cups.

Troubleshooting

Fruit is being chopped instead of juiced.

1. Fruit is too large for FNS-1800 Juicer.
Turn off FNS-1800 Juicer. Remove oversized fruit. Maximum diameter is 3-1/4".
2. Fruit feeder is sticky or unclean.
**Turn off FNS-1800 Juicer. Remove fruit.
Clean fruit lift.**
3. FNS-1800 Juicer not level. Locate FNS-1800 Juicer on level surface.

Fruit is fed two at a time.

1. Fruit is too small for FNS-1800 Juicer.
Turn off FNS-1800 Juicer. Remove undersized fruit. Minimum diameter is 2-1/2".

Fruit is not fed during every cycle.

1. The hopper mechanism is designed to put fruit into a single file and to break-up bridging before feeding. When hopper is full, it sometimes takes a couple of cycles to begin feeding. Large or out of round fruit sometimes do not feed well.

Cutter is constantly being damaged.

1. Red protective cap is not being placed on cutter prior to removing juice manifold and during handling.
2. Juice manifold is not secure.

Be sure spring hold-downs on lower cup are properly engaged.

1. Cutter is not installed properly, ensure arrows are aligned and cutter is flush onto manifold. Ensure screw is properly torqued, do not over-tighten. See cutter installation instructions.
2. Upper cup is damaged. Inspect inside of upper cup for damage to upper cutter.

Rebuilding

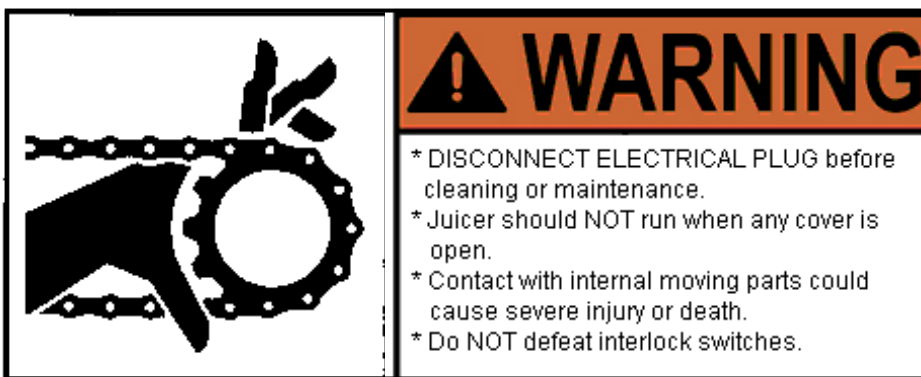

This section provides step-by-step instructions for completely rebuilding the FNS-1800 Juicer using Rebuild Kit, part number [060100813](#).

To replace any other components on the machine, contact Service.

FNS-1800 JUICER REBUILD KIT, 060100813

ITEM	QTY	PART NUMBER	DESCRIPTION
1	1	060100888	ORIFICE DRIVE ASSEMBLY
2	1	060100882	UPPER CRANK ASSEMBLY
3	2	060100870	SHAFT, UPPER LINEAR
4	1	060100836	SHAFT, ROTARY ORIFICE DRIVE
5	1	060100807	CHAIN GUIDE
6	1	060100803	SHAFT, ROTARY MAIN DRIVE
7	1	060100789	BLOCK, ORIFICE SHAFT BEARING BAR, FL 6061-T6
8	1	060100622	BLOCK, MAIN SHAFT BEARING BAR, FL 6061-T6
9	1	06002015	SHAFT, LOWER LINEAR
10	2	005575256	KEY, SQUARE, 1/4" X 1-1/4" LG, ROUND EDGES, ZINC PLATED CARBON STEEL
11	2	005575241	KEY, SQUARE, 1/4" X 1-1/4" LG, ROUND EDGES, ZINC PLATED CARBON STEEL
12	1	005220149	CHAIN, #60, 3/4" P, 64 LINKS, 48" LG
13	2	005098113	WASHER, THRUST, 1-1/4", GARLOCK G18DU
14	2	005098112	WASHER, THRUST, 1", GARLOCK G14DU

Rebuilding

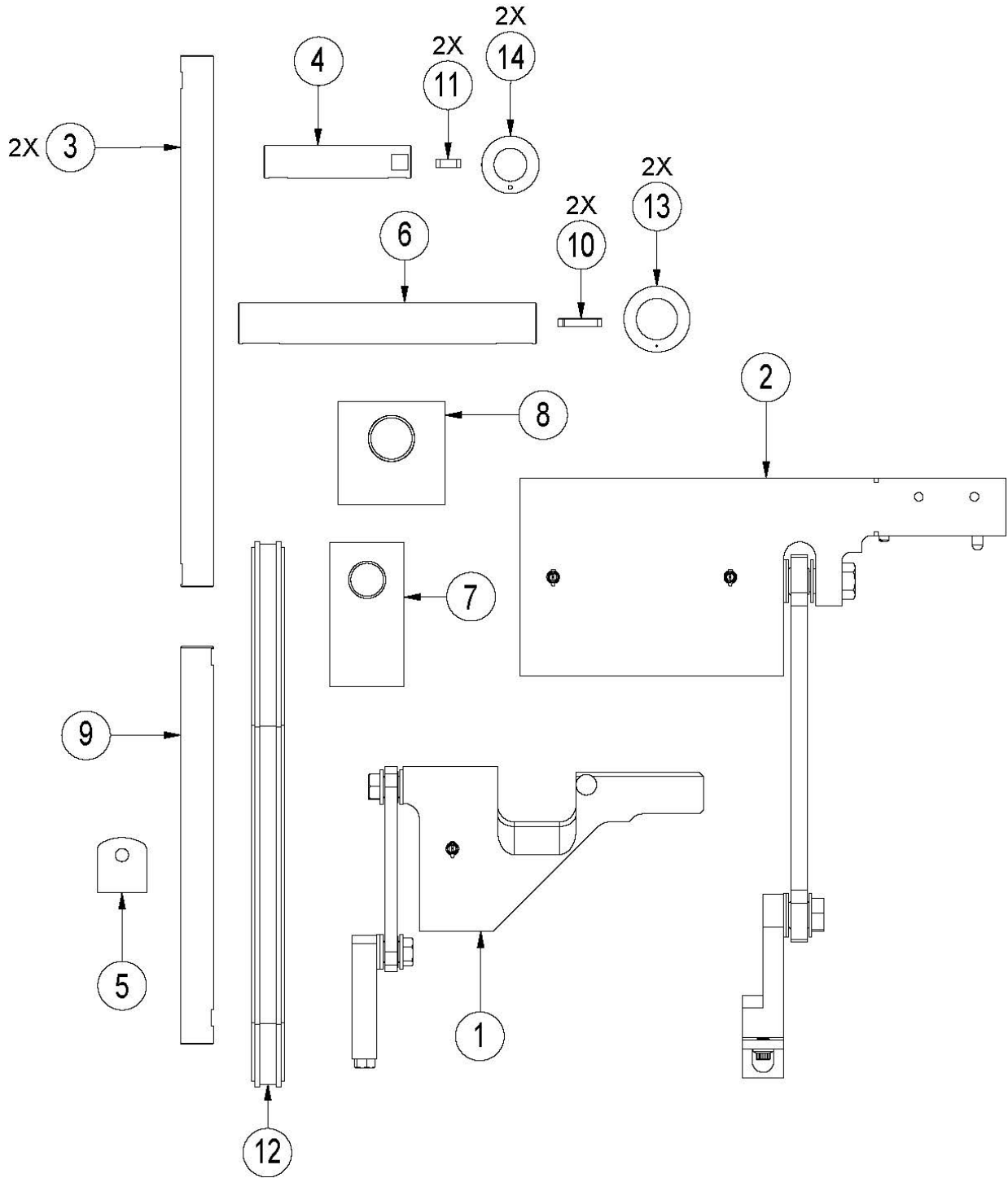
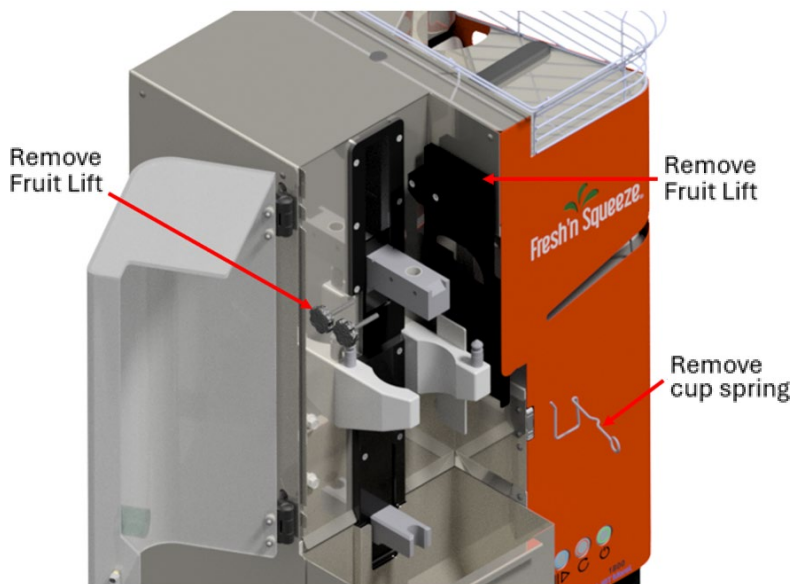

Figure 8. FNS-1800 Juicer, Rebuild Kit

Rebuilding

ALWAYS REMOVE POWER, UNPLUG AND VERIFY THAT MACHINE IS FULLY POWERED DOWN BEFORE WORKING ON MACHINE.

1. Remove juicing components.
2. Before powering the machine off, stop the machine in the DOWN position as shown without the juicing components in place. Remove the Fruit Lift and Upper Cup Spring.



3. Remove Splash Guards as shown below. Refer to picture when reinstalling.

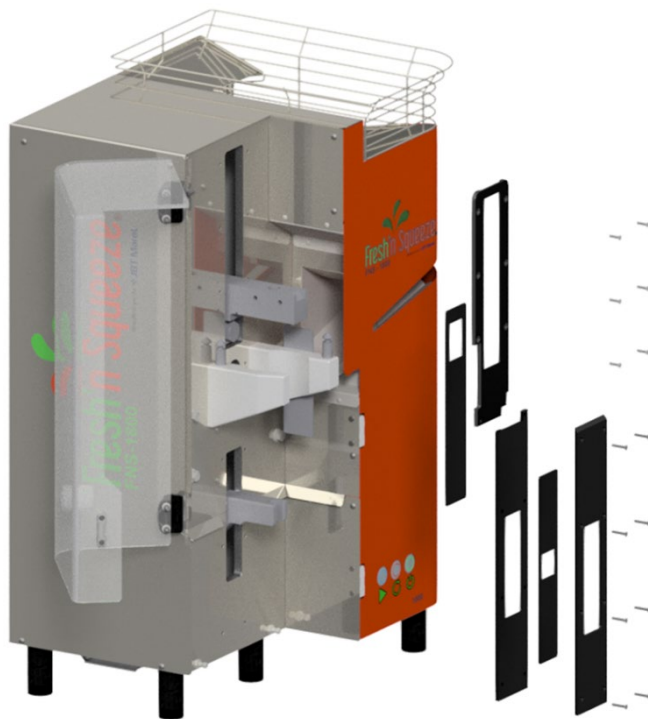

Rebuilding

4. Remove juicing cover door, side access door and rear service panel. Disconnect rear panel safety switch and slide cord out of cord holder. Unscrew all seven of rear panel mounting screws using phillips head screwdriver.

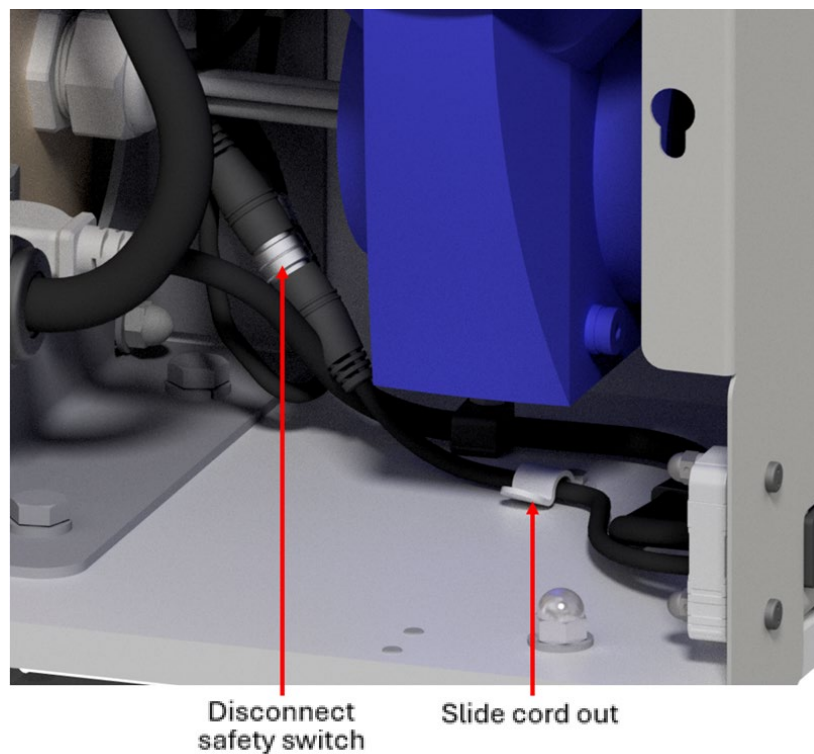

Rebuilding

5. Remove the chain by releasing tension from the tensioner. Loosen positioning nut and coupling nut on tensioner. Lower tensioner using tensioner bolt until chain is completely slack.

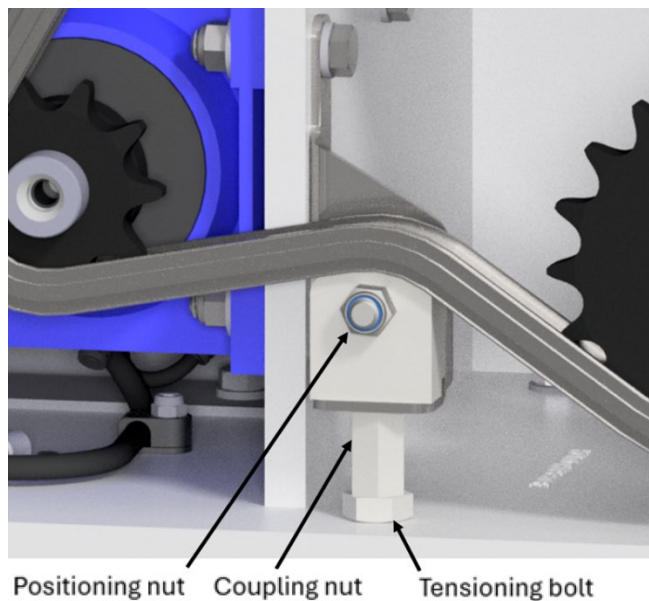

6. Locate the master link along the chain, as shown below.

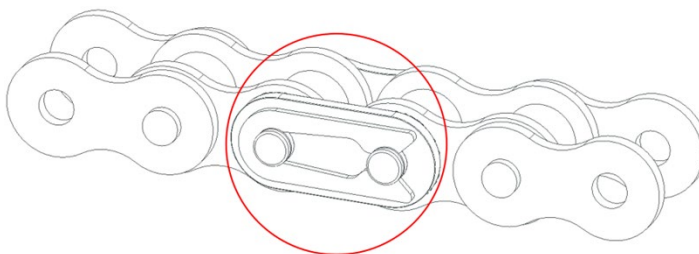

7. Once the chain is loose, remove the clip that holds the master link and slide it off the chain.

NOTE: If the upper arm is not in the lowest position possible, be cautious that the arms and cranks will fall once the chain is removed

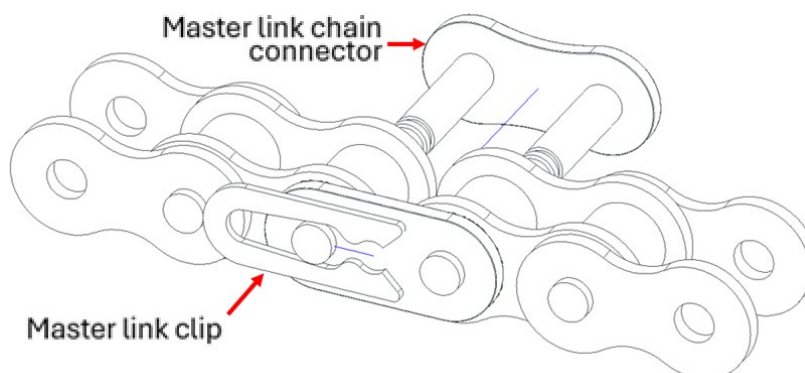

Rebuilding

8. Remove positioning nut and replace old Guide Block with new Guide Block from kit.

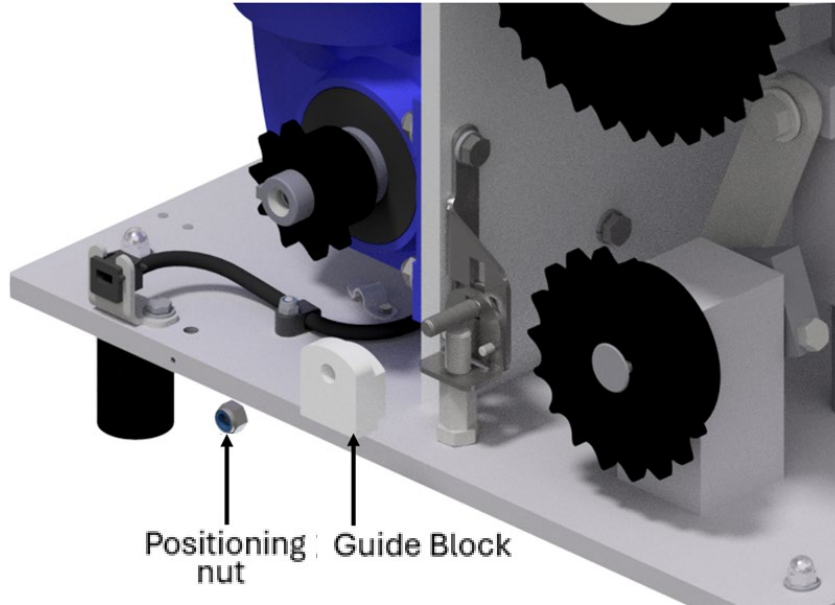

9. Remove the top cover and the hopper by removing the three screws holding it in place.

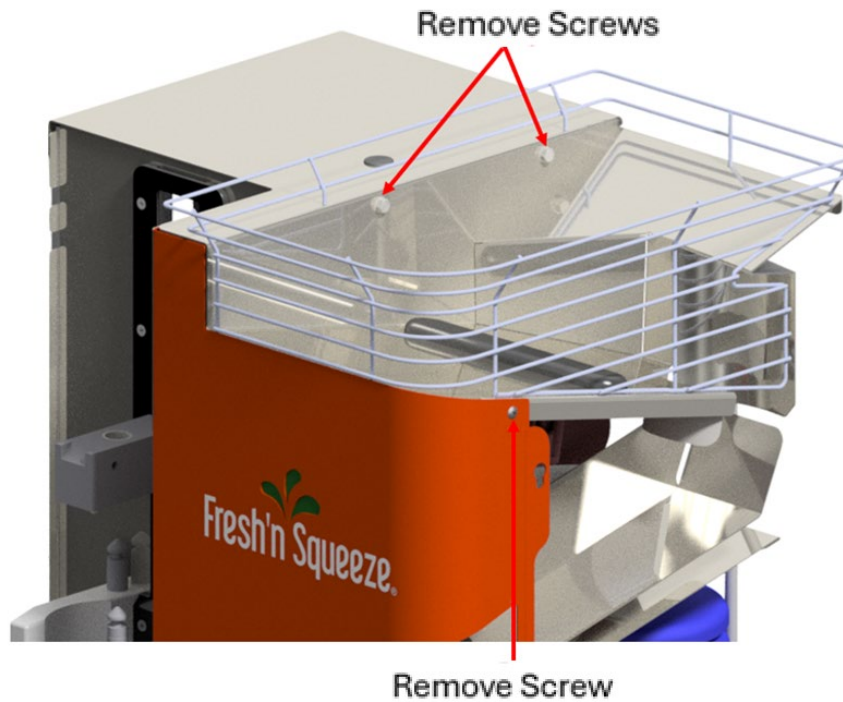

Rebuilding

10. Unclip the connector to the hopper motor and slide the top cover towards the back of the machine to remove.

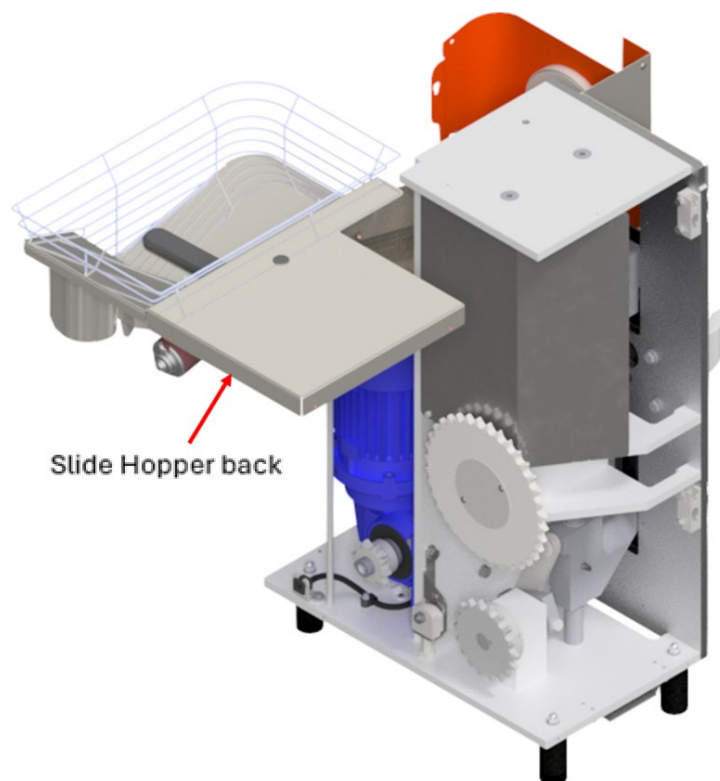
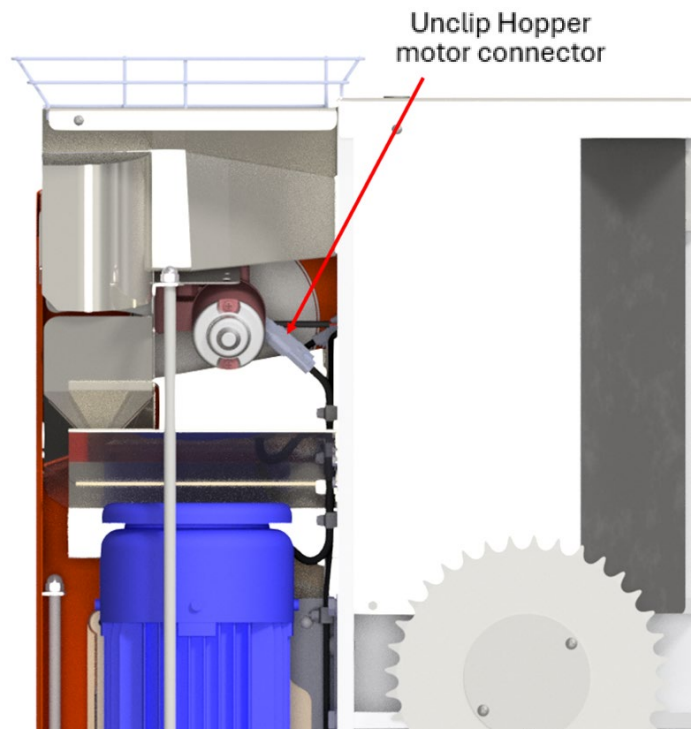

Rebuilding

11. Remove sprocket cover by unscrewing the four bolts holding it in place.

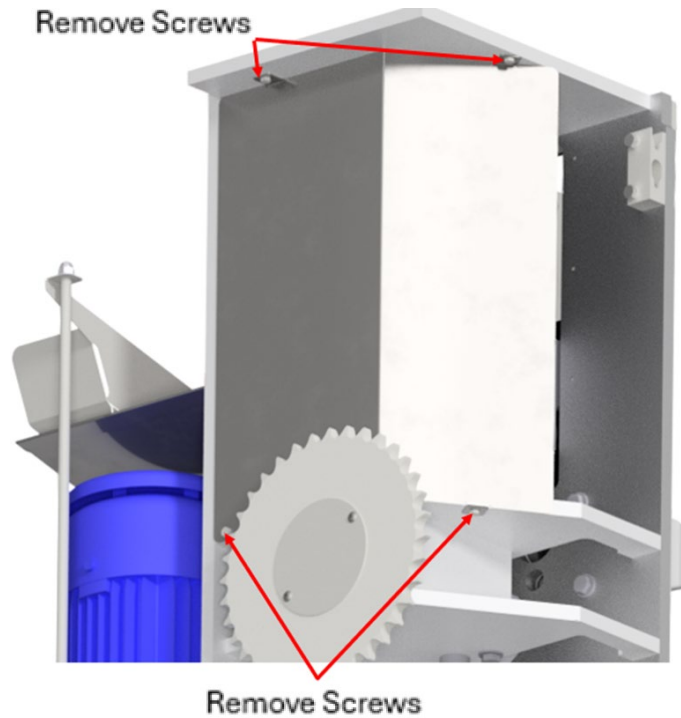

12. Chuck the Upper Arm up in the halfway position in order to better access the bolts that are clamping the sprocket and crank arm to the main drive shaft. This is best done with a wooden block or something similar. This will allow access to the clamping bolts on the sprocket and the Upper Crank. Loosen the Upper Crank bolt first. Then, using a larger flathead screwdriver or a crowbar, pry the Upper crank forward to unseize the Upper Crank from the drive shaft. This will make it easier in the end to pull the drive shaft out.

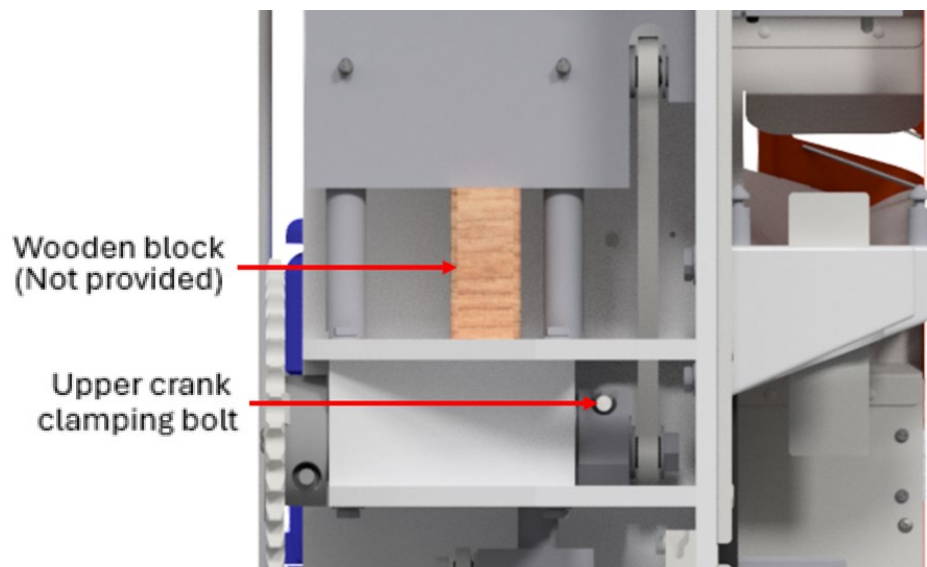

Rebuilding

13. After the Upper Crank is loose, loosen the sprocket clamping bolt and slip the sprocket back and off the Drive Shaft. Remove the Thrust Washer and Shaft Key as well.

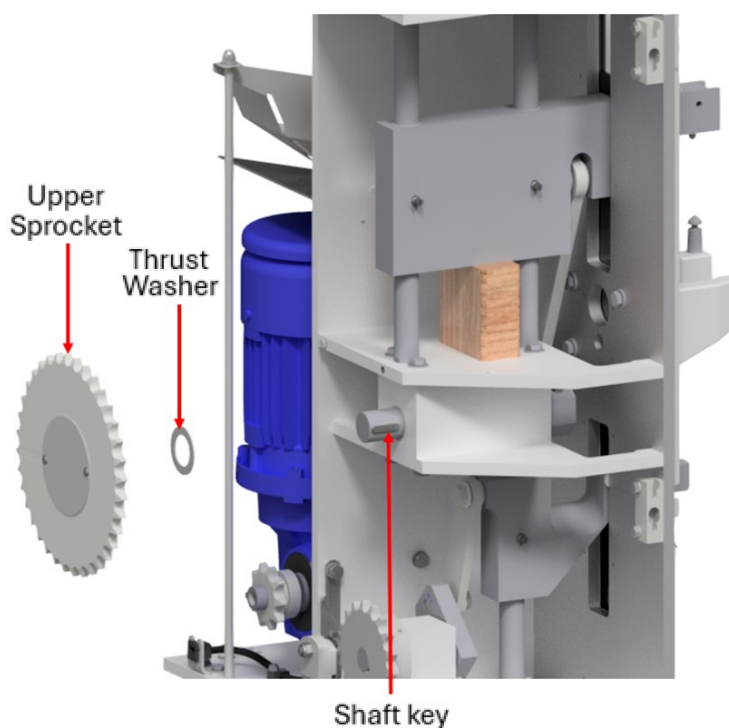
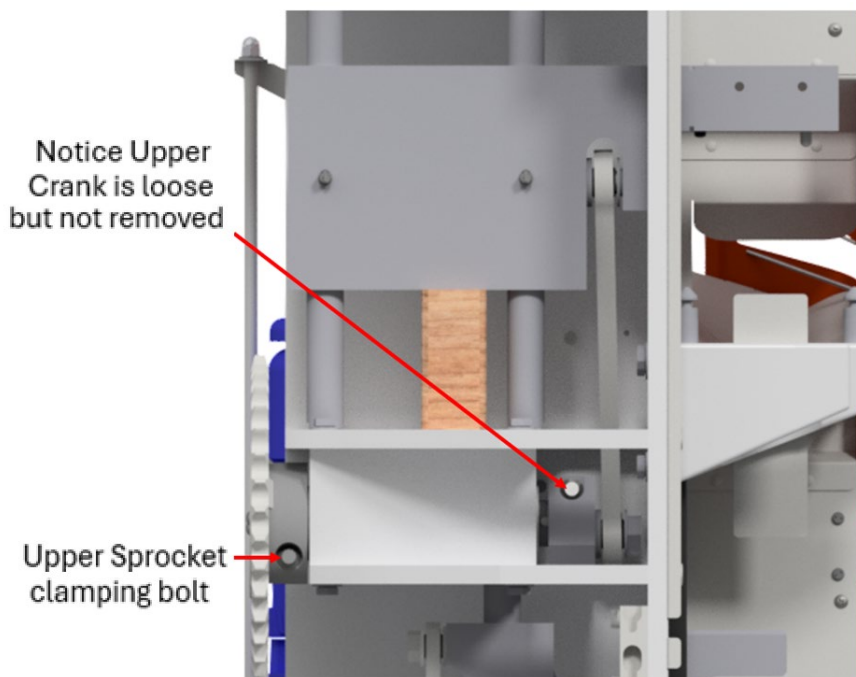

Rebuilding

14. Slip the Upper Crank assembly the rest of the way off the drive shaft and then remove the Shaft Key and Thrust Washer. This will allow the drive shaft to be pulled out and replaced.

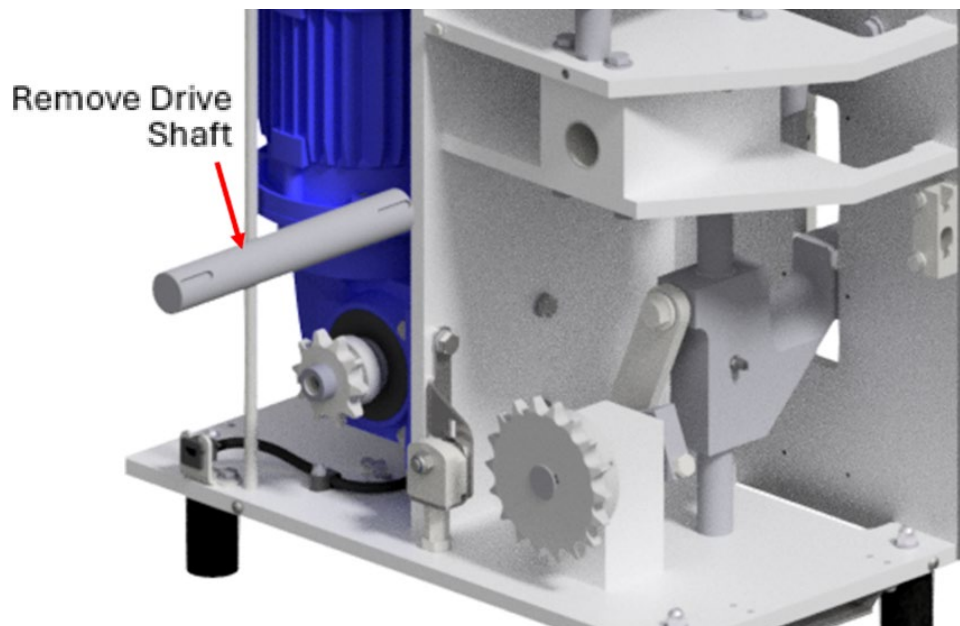
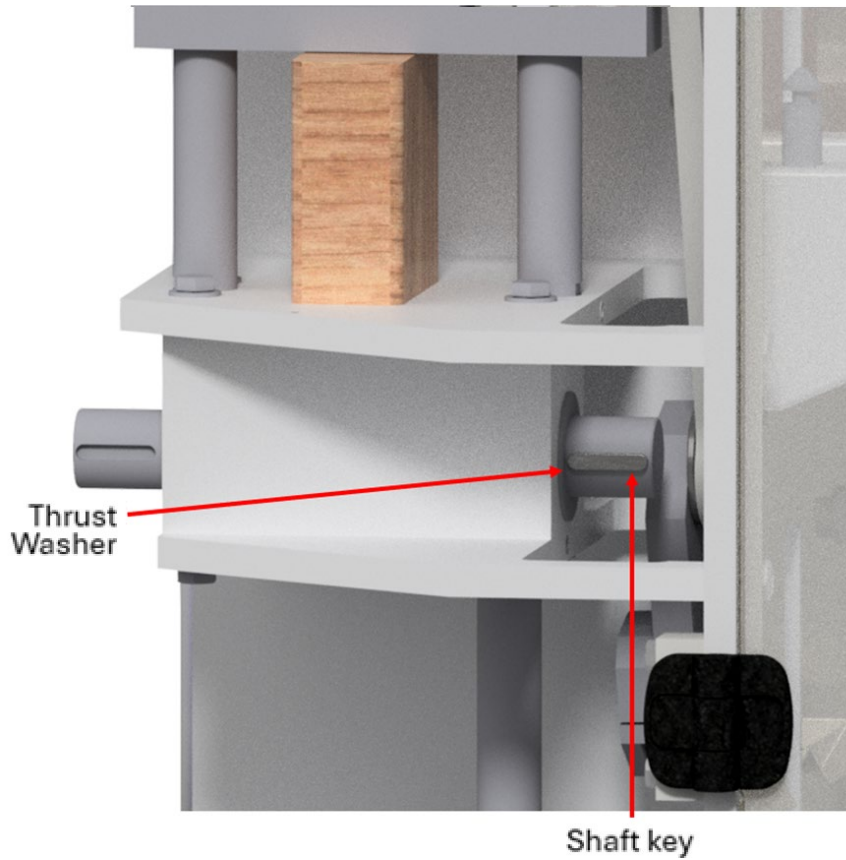

Rebuilding

15. Using a 3/16" hex key or T-Handle hex key, loosen the set screws that are holding the Upper Guide Shafts in place. There is one per Guide Shaft and they are located at the base of the shafts screwed into the side of the upper middle plate.

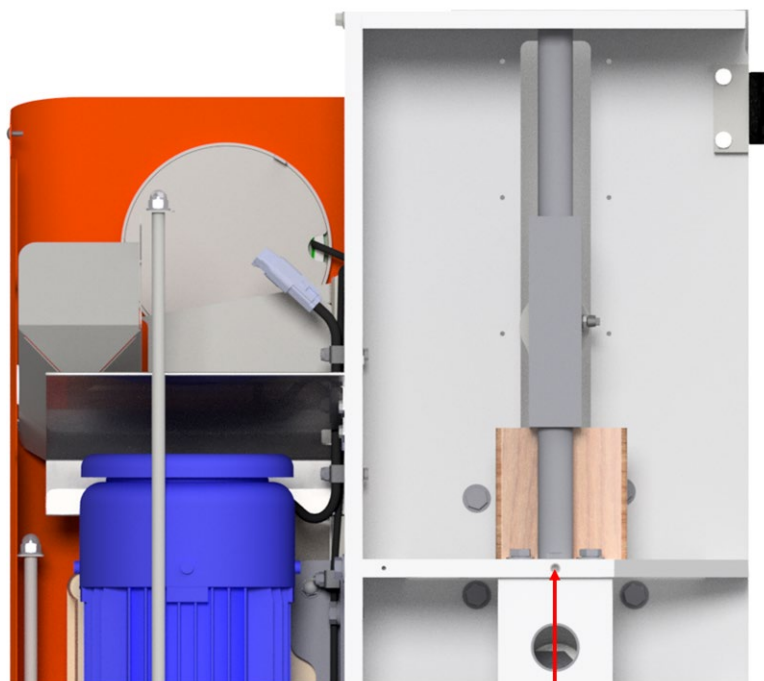

Set Screw for
rear Guide Shaft



Front Upper Guide
Shaft Screw

Rebuilding

16. Remove the Guide Shafts by twisting them out and lifting up. If they do not easily come out, there are 3/8"-16 tapped holes on the top of the Guide Shafts that a bolt can be used to pry them up and out.



Rebuilding

17. The Upper Arm assembly can now be removed.

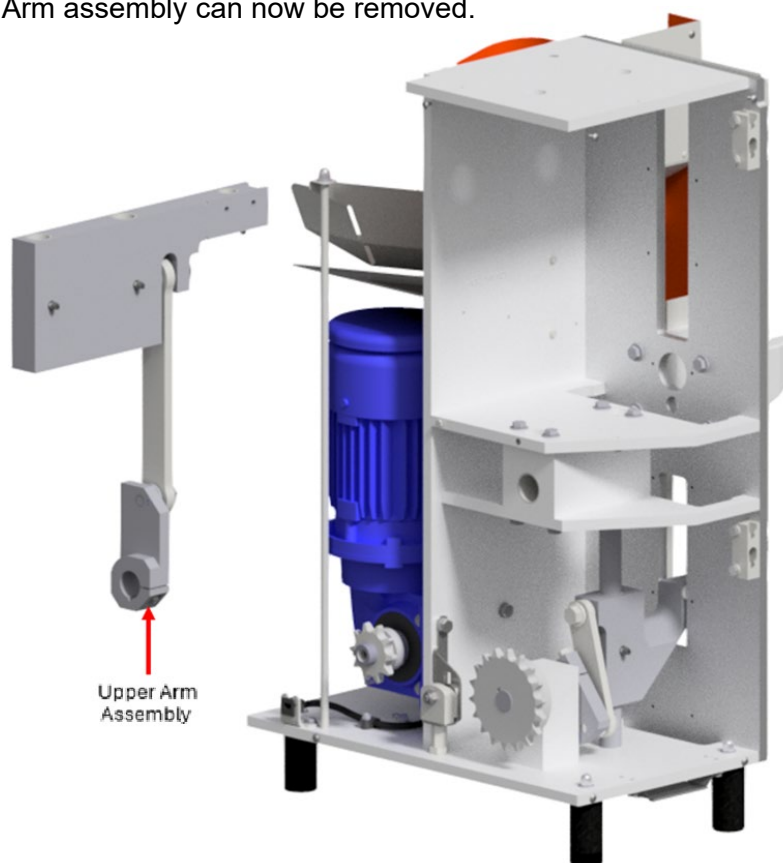

18. Set the machine on its side to be able to remove the Lower Sprocket, as shown.

CAUTION: THE MACHINE IS HEAVY AND SHOULD BE TIPPED CAUTIOUSLY BY TWO PEOPLE.

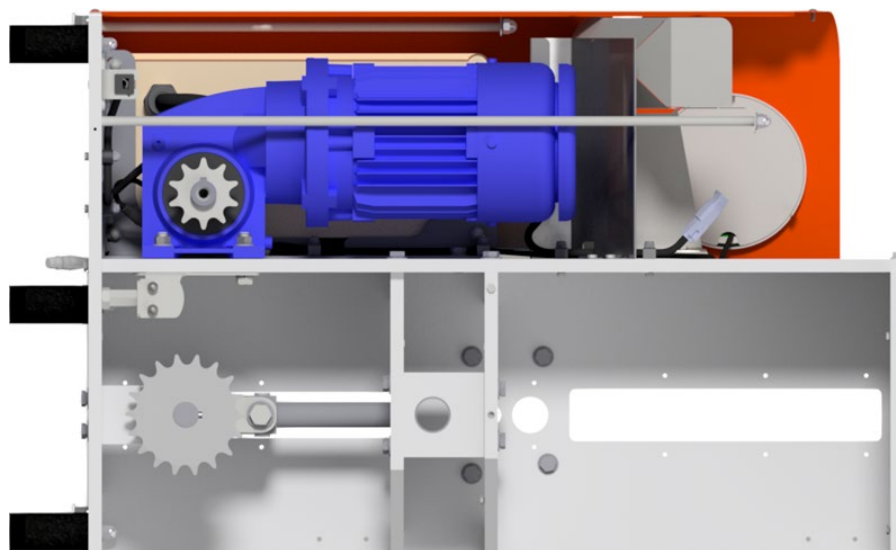

Rebuilding

19. Loosen the set screws that are holding the Lower Sprocket in place with a 5/32" hex key. There are two set screws. Also loosen the Lower Crank clamping bolt with a 9/16" socket.

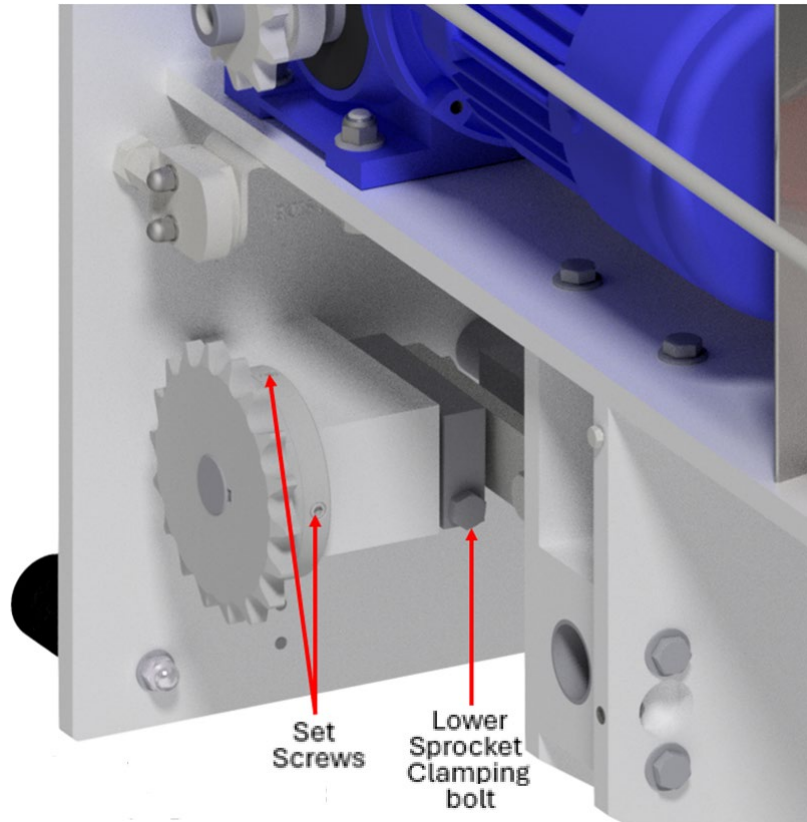

20. Remove the Lower Sprocket, Thrust Washer and Shaft Key.

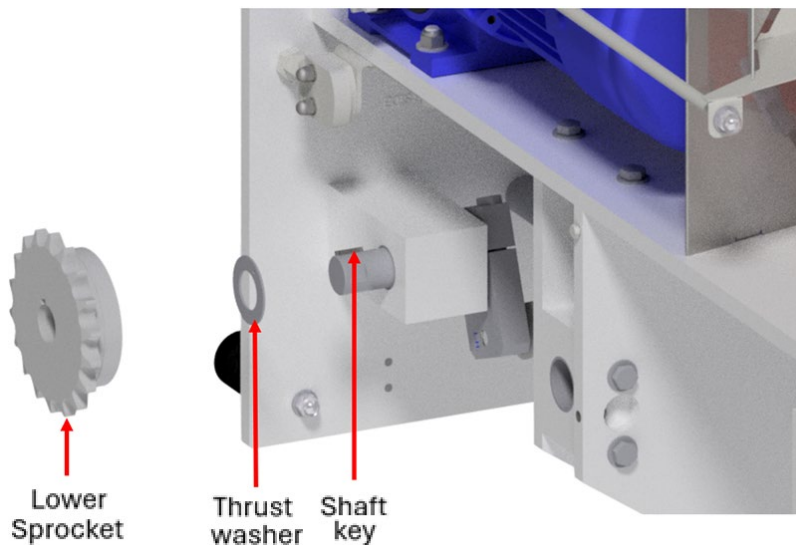

Rebuilding

21. Remove the Lower Guide Shaft by loosening the set screw at the top of the Lower Guide Shaft with a 5/32" hex key. Twist the Guide shaft until it comes out of place. If it does not come out after twisting, a 3/8"-16 bolt can be placed in the Guide Shaft from below to pry the Guide Shaft out of place.

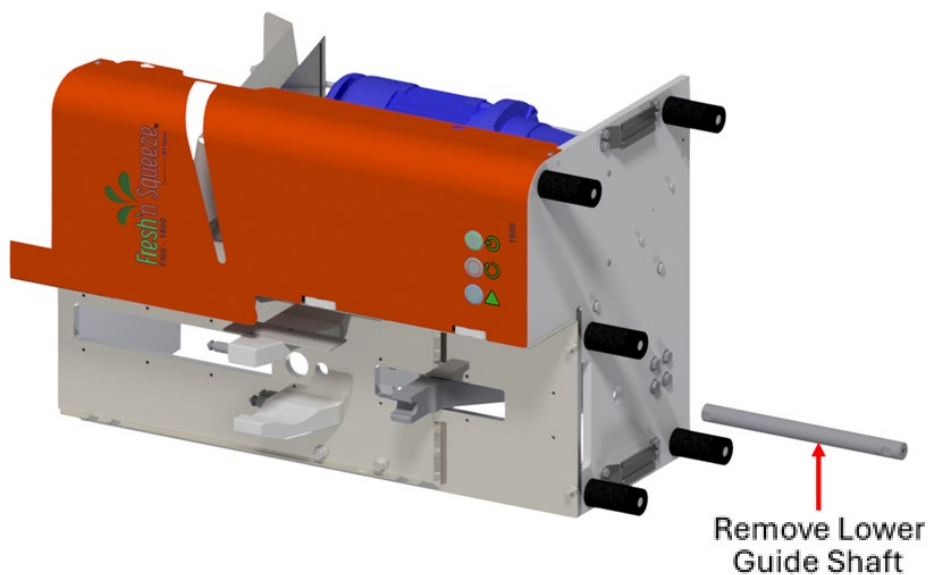
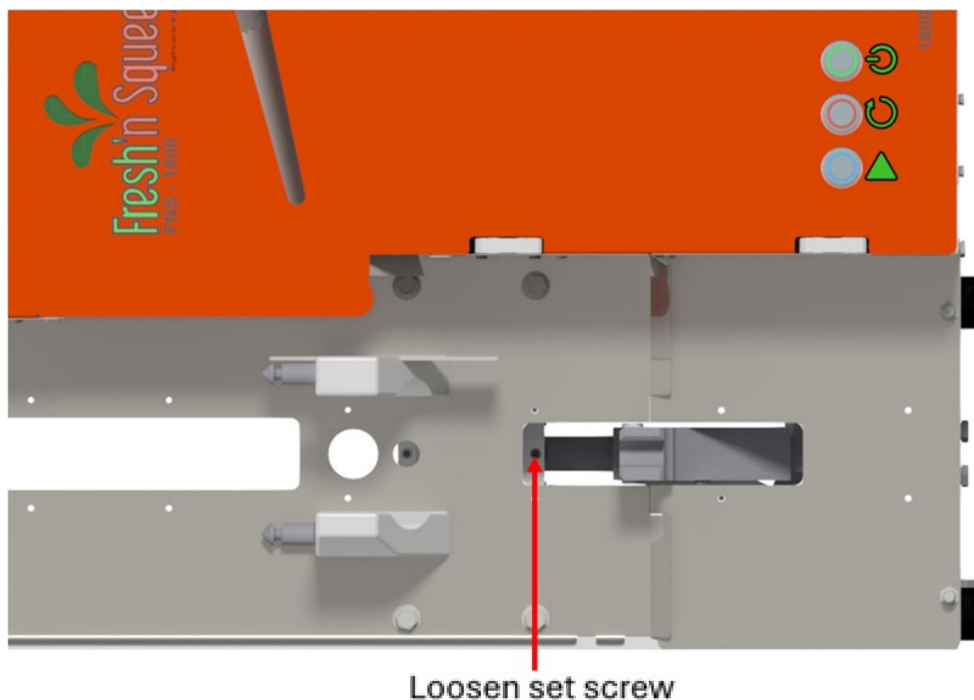

Rebuilding

22. Remove Lower Arm assembly from Lower Drive Shaft and remove Thrust Washer and Shaft Key as well, before sliding Lower Drive Shaft out.

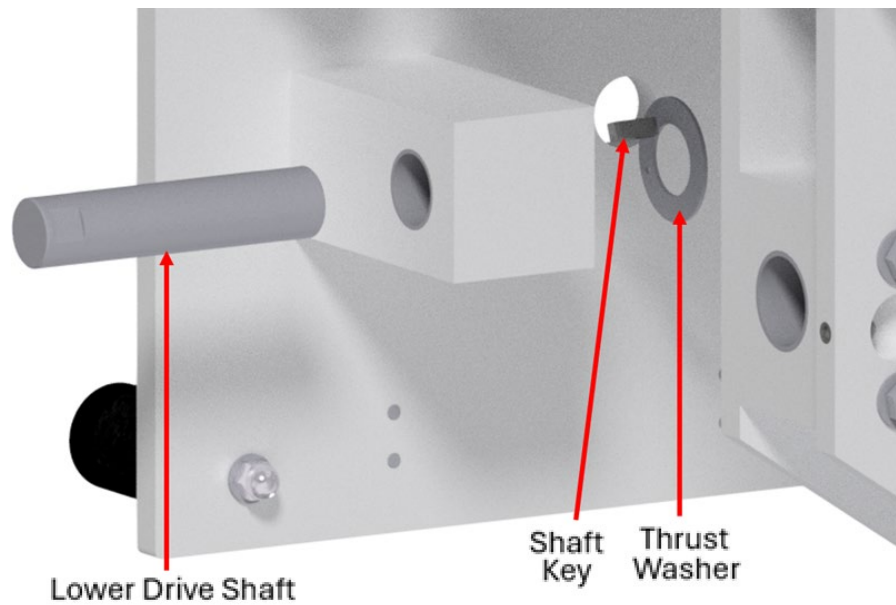
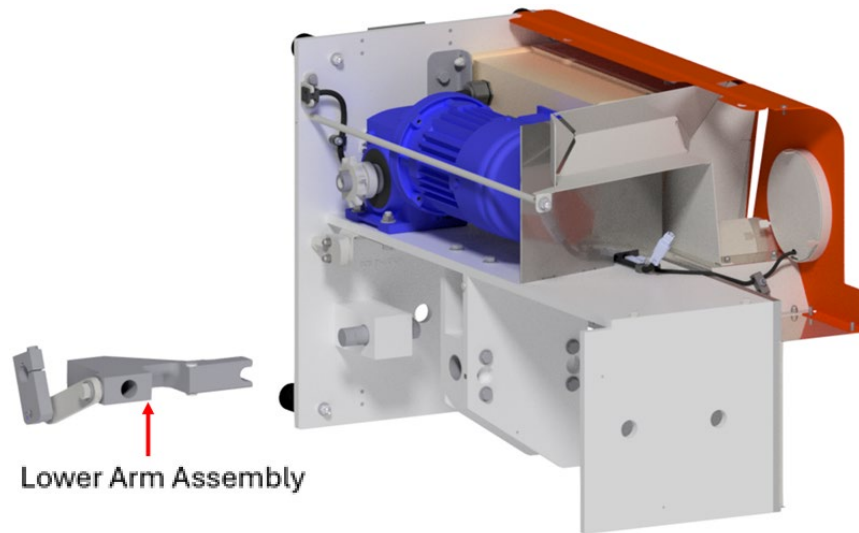

Rebuilding

23. Unbolt Lower Drive Shaft Block from frame and remove and replace with new Lower Drive Shaft Block.

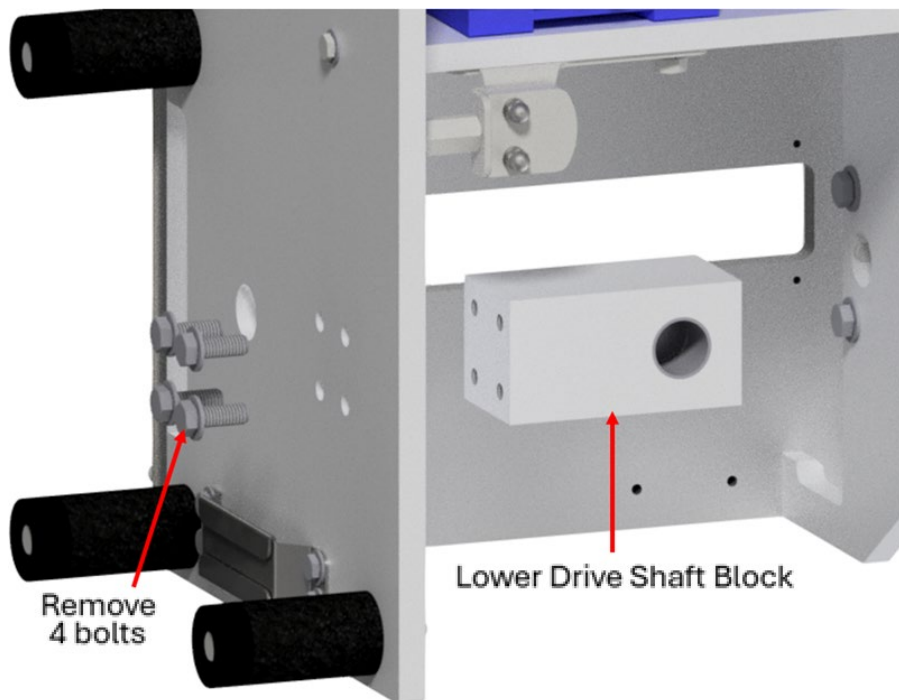

24. Unbolt Main Drive Shaft Block and remove and replace with new Main Drive Shaft Block.

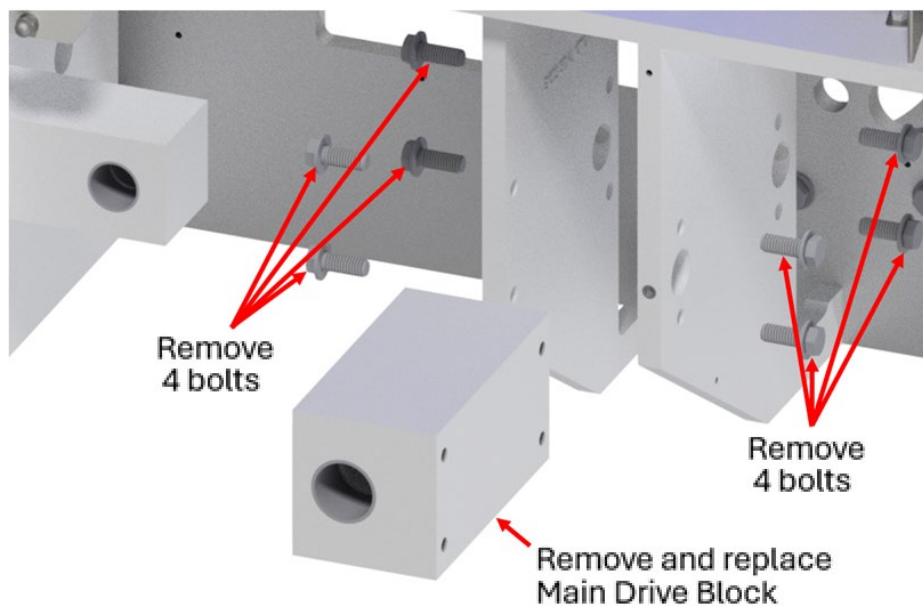

Rebuilding

25. After replacing the Drive Blocks, reinstall all new components on machine that came with Rebuild Kit. Refer to disassembly instructions to reinstall. The chain should have about ¼" of slack on the longest side. Do not forget to install Thrust Washers behind the cranks and sprockets. The Thrust Washers should be installed with the ceramic (non-metal) side facing away from the Drive blocks.

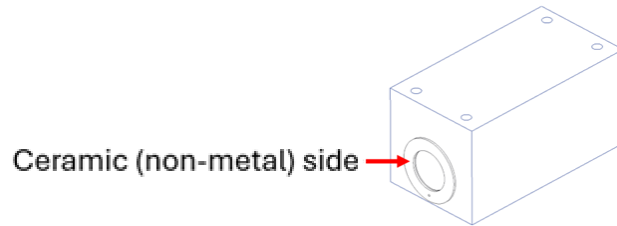

26. Torque bolts to the torque specs for the Lower Crank, Upper Crank and Upper Sprocket as shown below.

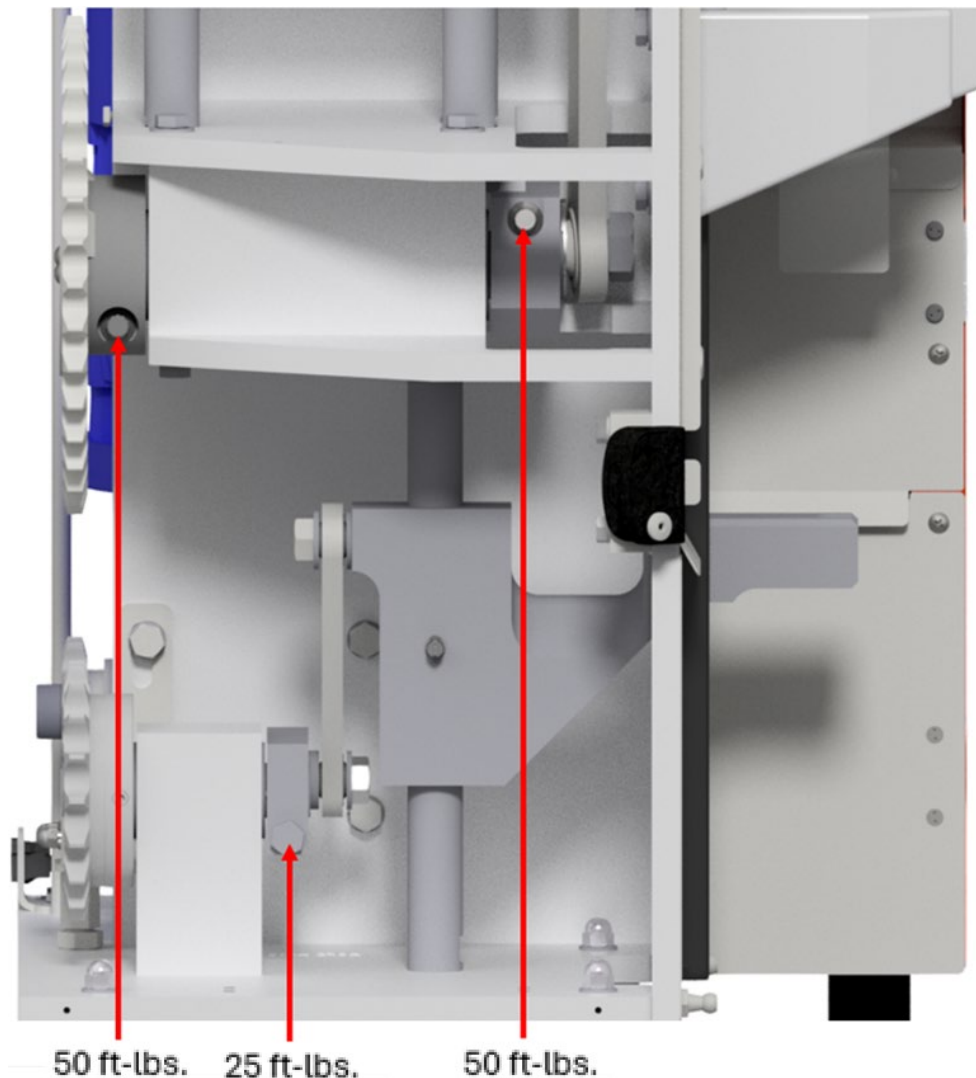

Illustrated Parts List

Assembly drawings in this chapter provide a list of part numbers for replaceable parts available for the FNS-1800 Juicer.

Parts List / Parts Drawing	Page
1. Juicing Cover Door	48
2. Juicing Components	49
3. Cup Mounts	50
4. Splash Guards	51
5. Upper Crank Assembly (p/n 060100882)	52
6. Orifice Drive Assembly (p/n 060100888)	53
7. Hopper Motor Replacement	54
8. Motor Replacement	55
9. Safety Switch Replacement	56
10. Power Cord	58
11. Electrical Panel Assembly, 115V (p/n 060100736)	59
12. Electrical Diagram, 115V (p/n 060100736)	60
13. Electrical Panel Assembly, 230V (p/n 060100918)	61
14. Electrical Diagram, 230V (p/n 060100918)	62
15. Waste Bin	63
16. Cover Assembly	64
17. Light Replacement	66
18. Feet Replacement	67

1. Juicing Cover Door

Item	Qty	Part Number	Description
1	4	060100947	KEY PIN, JUICING COVER, DOOR, HINGE
2	1	060100821	JUICING COVER DOOR, PC
3	1	009998004	BIT, SPANNER INSERT, #8, 1/4" HEX SHANK
4	2	060100841	HINGE, SET-ANGLE WITH SNAPON COVER, BLACK ACETAL, 150 DEG SET ANGLE
5	6	004815126	METAL BONDED SEALING WASHER
6	4	004605073	SPACER, UNTHREADED, 5/16" OD X 3/16" LG, NYLON, OFF WHITE
7	2	004605037	SPACER, UNTHREADED, 5/16" OD X 3/16" LG, NYLON
8	4	004392225	SCREW, MACHINE, PAN, PHILLIPS, 8-32 1/2" LG, SS
9	4	004392224	SCREW, MACHINE, PAN, PHILLIPS, 8-32 5/8" LG, SS
10	2	004392197	SCREW, MACHINE, PAN HEAD, SPANNER TYPE, #8-32 X 1" LG, SS
11	6	004156166	NUT, ACORN, LOCK, DISTORTED THREAD, 8-32, 18-8SS

ALWAYS REINSTALL SAFETY SWITCH ACTUATOR WHEN REPLACING DOOR. OTHERWISE, MACHINE WILL NOT RUN.
NEVER REMOVE ACTUATOR FROM DOOR TO DEFEAT SAFETY SWITCH. THIS COULD RESULT IN INJURY AND WILL VOID WARRANTY.

TO REMOVE SPANNER SCREWS, ITEM 00998004 IS REQUIRED

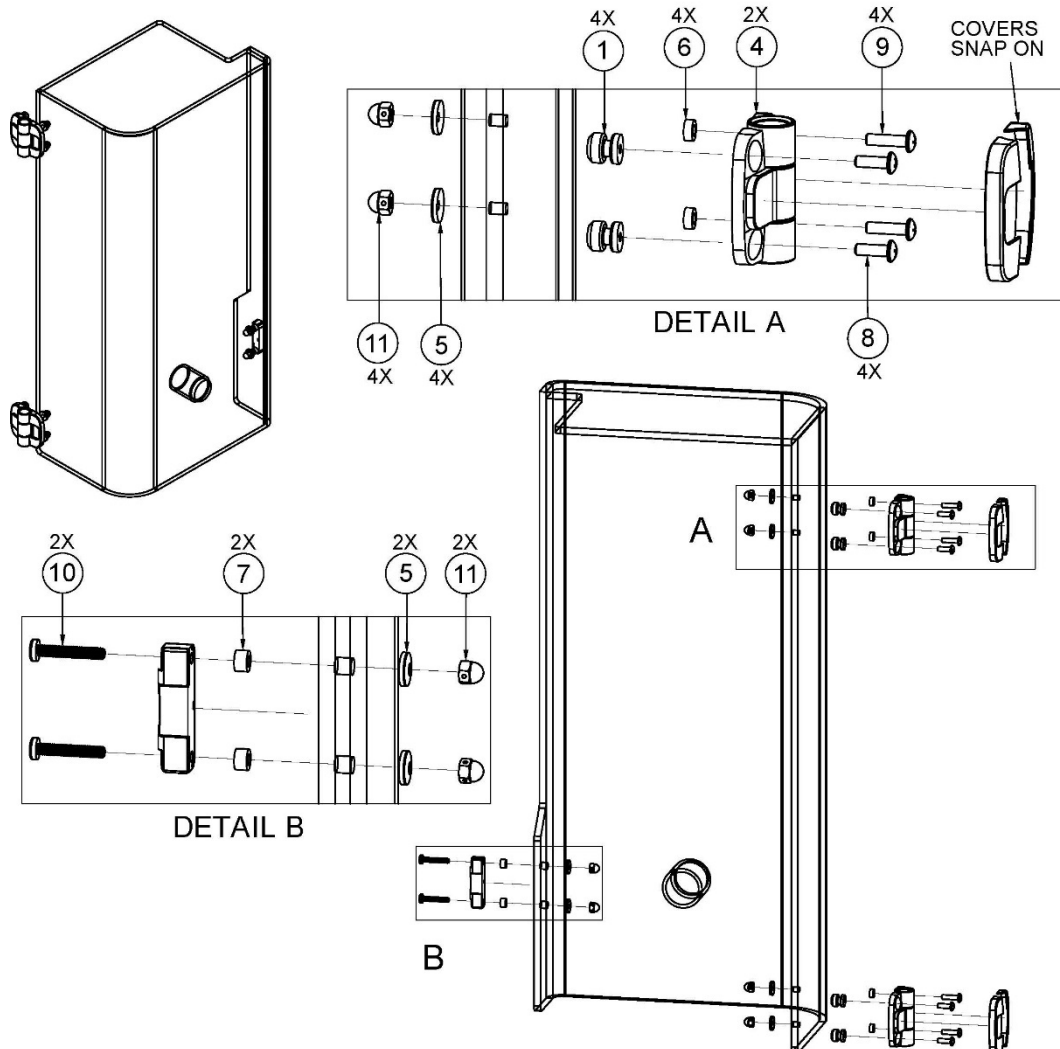

2. Juicing Components

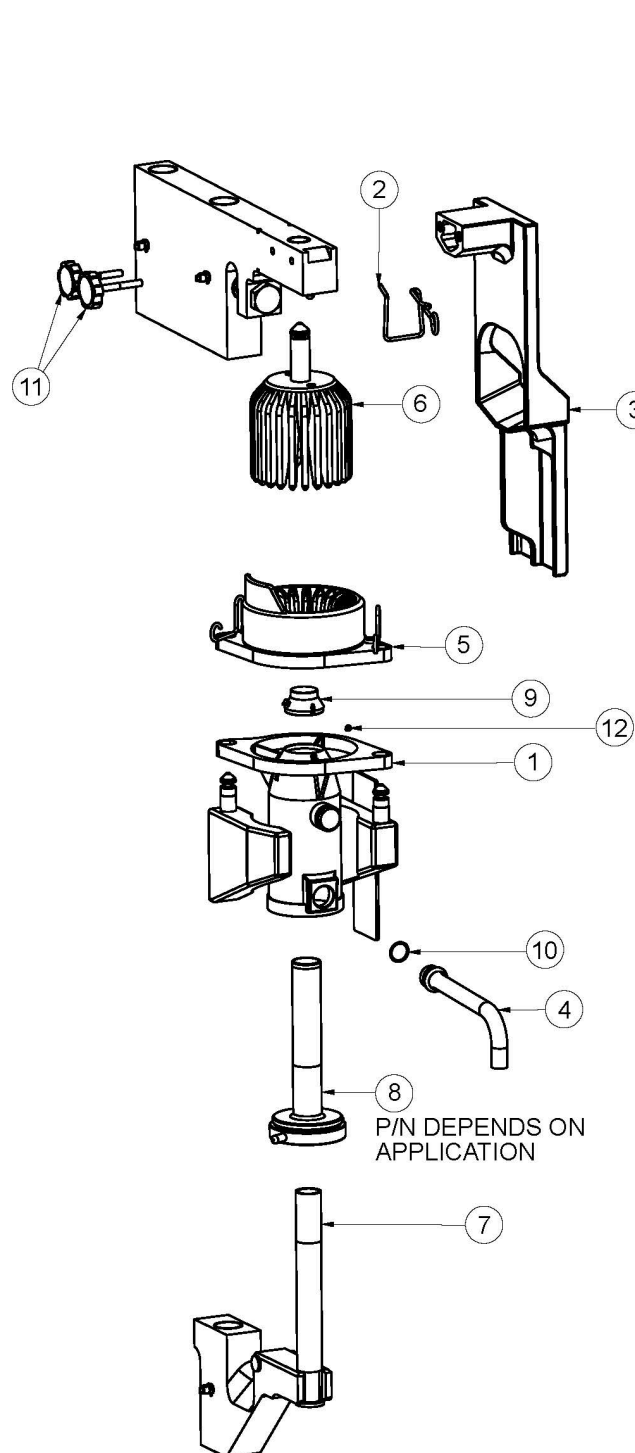

<u>Item</u>	<u>Qty</u>	<u>Part Number</u>	<u>Description</u>
1	1	060100949	MANIFOLD ASSEMBLY, VENTED
2	1	060100806	SPRING,UPPER CUP
3	1	060100798	FRUIT LIFT ASSEMBLY, THREADED INSERTS
4	1	060100782	NOZZLE
5	1	06002063	LOWER CUP ASSEMBLY
6	1	06002062	UPPER CUP ASSEMBLY
7	1	06002038	ORIFICE TUBE
8	1	06002119	STRAINER TUBE, 0.028 LEAST PULP
		06002022	STRAINER TUBE, 0.033 LESS PULP (STANDARD)
		06002088	STRAINER TUBE, 0.040 MORE PULP
		06002089	STRAINER TUBE,0.055 MOST PULP
9	1	06000225	CUTTER WITH SCREW
10	1	007486132	O-RING, NOZZLE, 3/4" ID X 7/8" OD
11	2	004445047	SCREW, THUMB, 1/4-20 X 2" LG 18-8SS
12	1	004406003	SCREW, MACH, ROUND, 4-40 X 3/16" LG, 304SS

3. Cup Mounts

<u>Item</u>	<u>Qty</u>	<u>Part Number</u>	<u>Description</u>
1	1	060100867	RH CUP MOUNT ASSEMBLY
2	1	060100866	LH CUP MOUNT ASSEMBLY
3	1	06002019	GUIDE, FRUIT COUNTER TOP
4	2	06002018	PIN, LOWER CUP
5	4	004816080	WASHER, PLAIN, 3/8" N , 304SS
6	2	004385029	SCREW, MACH. FL, 8-32 X 3/8, SS
7	4	004352395	SCREW, CAP, HEX, 3/8 X 1, SS
8	4	004221099	PIN, SPRING, 1/4" X 7/8" LG, 316SS

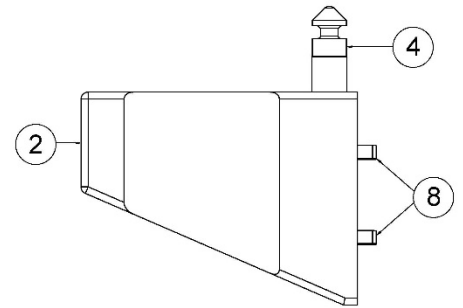
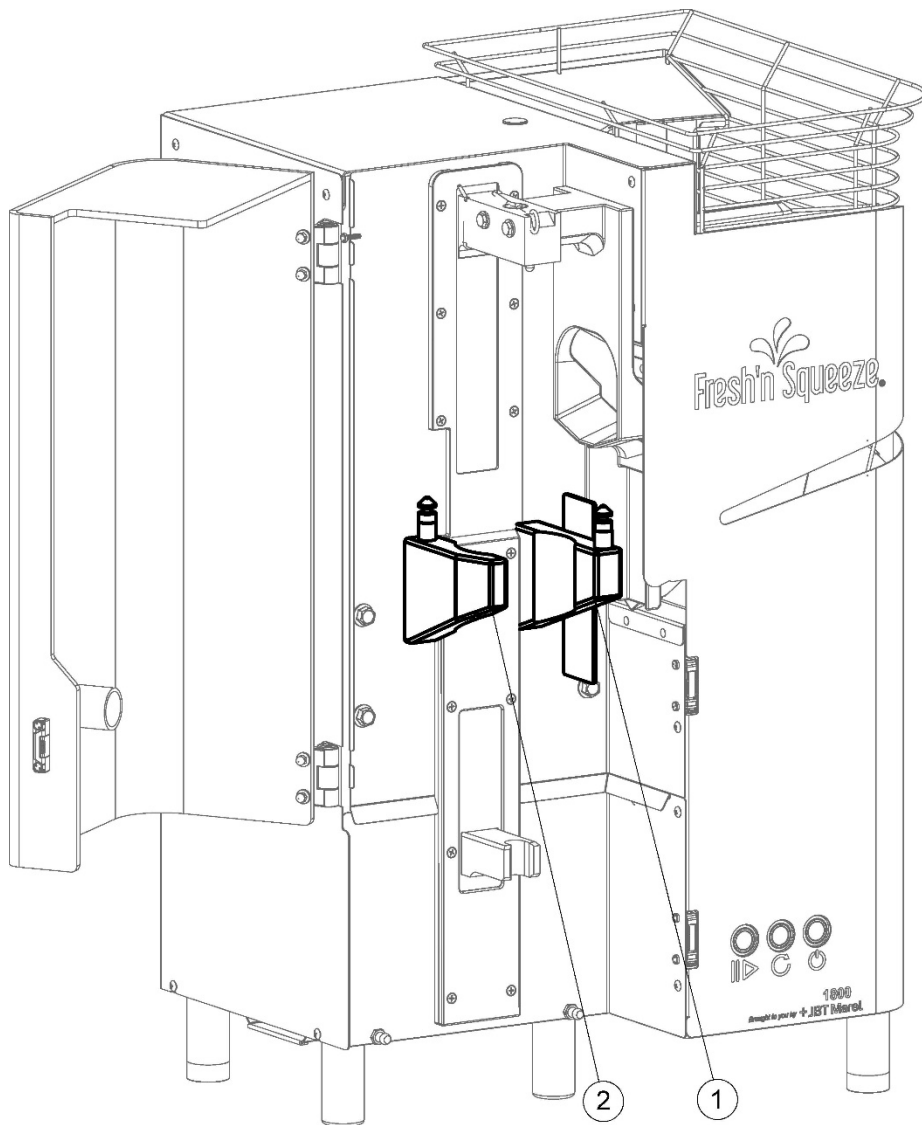

HARDWARE COMES WITH ASSEMBLY

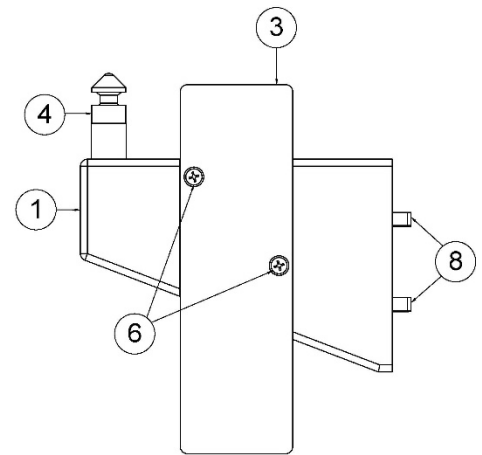

HARDWARE COMES WITH ASSEMBLY

4. Splash Guards

Item	Qty	Part Number	Description
1	1	060100787	UPPER GUARD COVER, ACETAL CP, BLACK, FDA APPROVED
2	1	060100786	LOWER GUARD BASE, ACETAL CP
3	1	060100785	FRONT LOWER GUARD COVER, ACETAL CP
4	1	060100784	SPLASH GUARD, LOWER, ACETAL, BLACK, FDA APPROVED
5	1	060100783	SPLASH GUARD, UPPER, ACETAL CP, BLACK, FDA APPROVED
6	6	004385056	SCREW, MACH FLAT HEAD, #10-24 X 3/4" LG, PHILLIPS HEAD, 304SS
7	8	004385055	SCREW, MACH, FLAT HEAD, #10-24 X 1" LG , PHILLIPS HEAD, 304SS

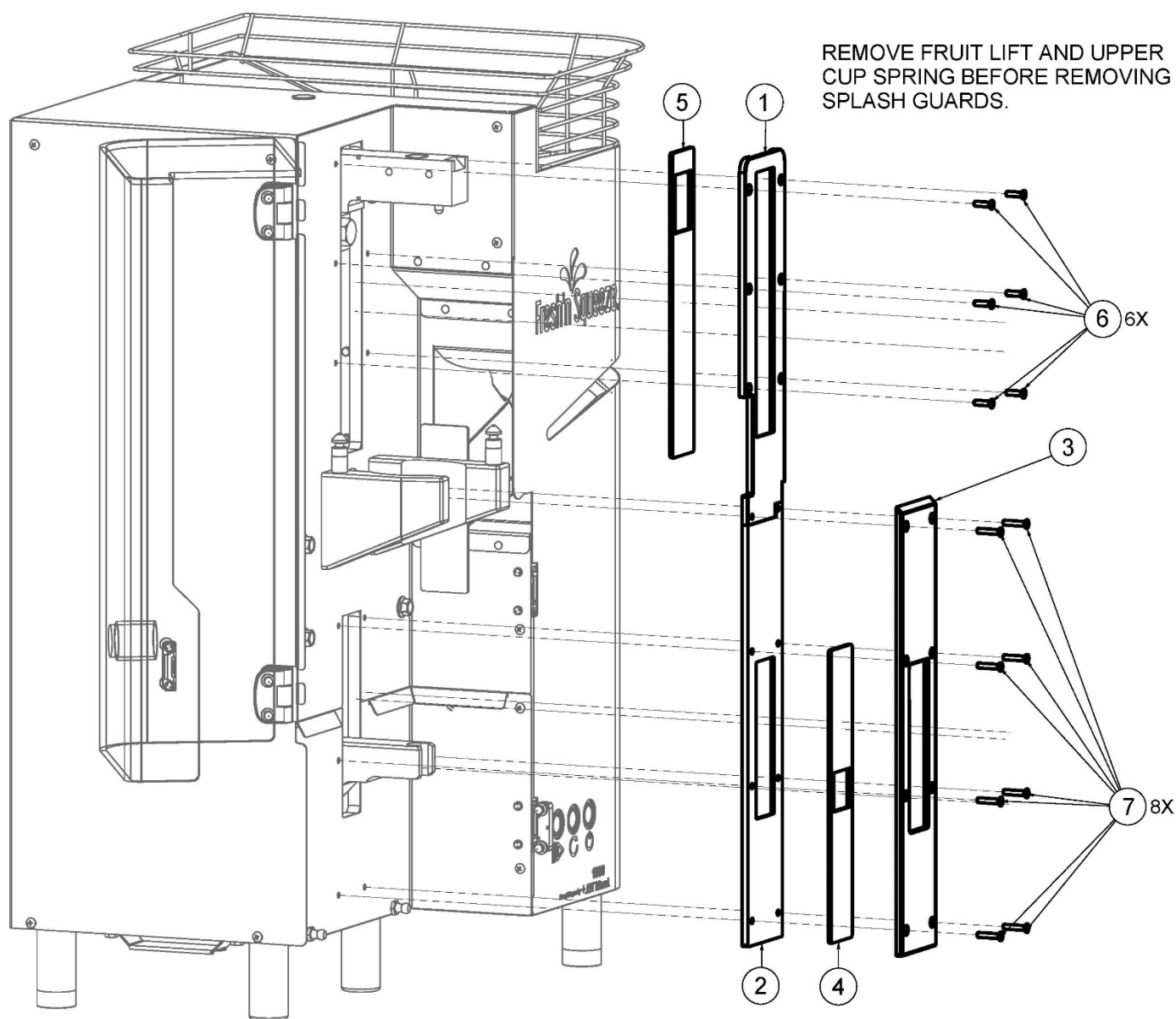

5. Upper Crank Assembly (p/n 060100882)

<u>Item</u>	<u>Qty</u>	<u>Part Number</u>	<u>Description</u>
1	1	060100881	ARM, UPPER CUP DRIVE
2	1	060100892	CRANK, UPPER CUP DRIVE
3	1	060100877	ARM ASSEMBLY, LINK, UPPER CUP
4	1	06010258	SCREW, UPPER CUP CRANK, LEFT-HAND THREAD
5	1	06010323	UPPER CUP ARM BOLT, CUT
6	1	06000057	LOCK- ROD END
7	6	004816120	WASHER, PLAIN, 5/8", SS

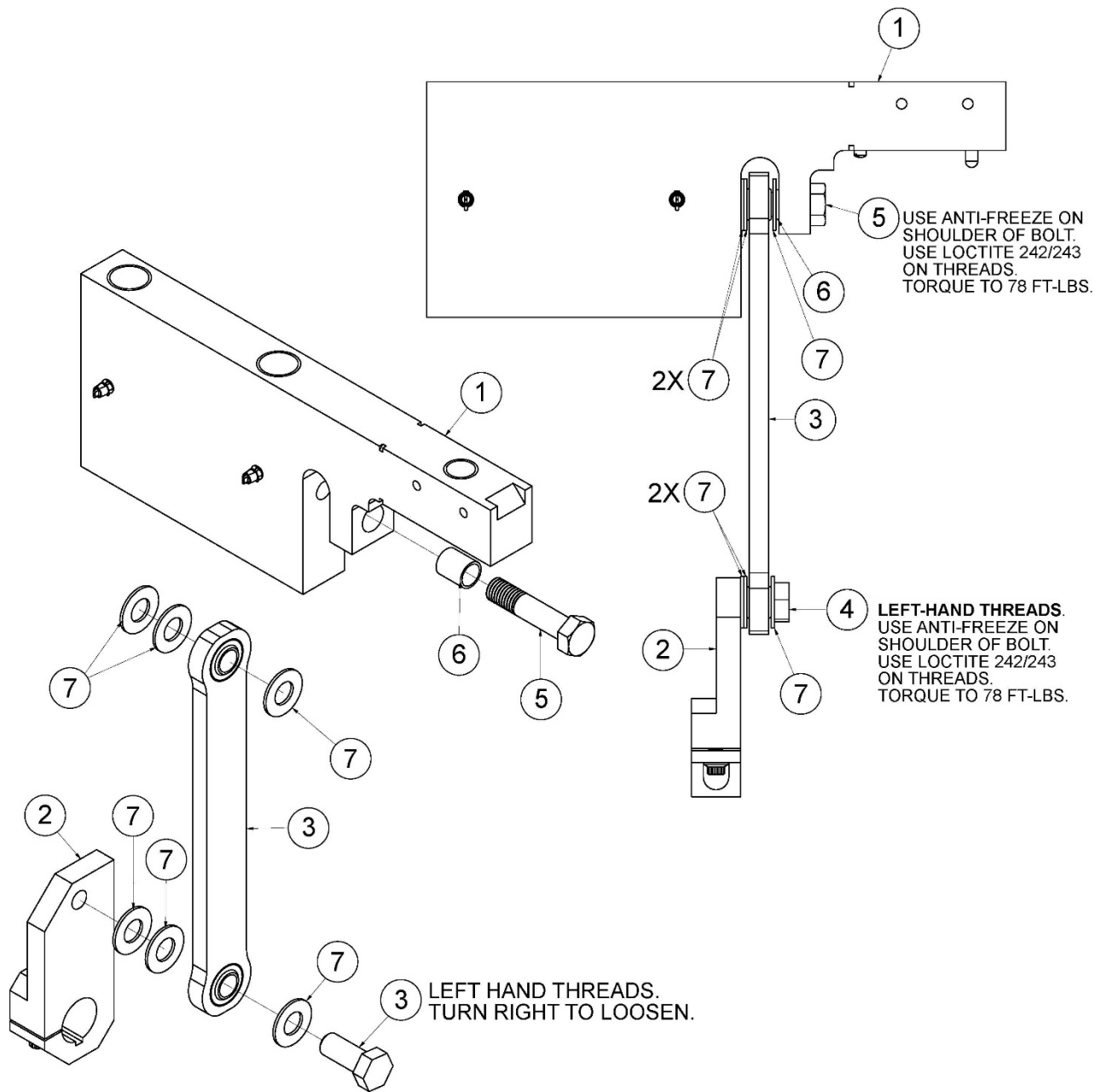

6. Orifice Drive Assembly (p/n 060100888)

Item	Qty	Part Number	Description
1	1	060100894	CRANK, ORIFICE TUBE DRIVE
2	1	060100890	ASSEMBLY. ARM, LINK, ORIFICE DRIVE
3	1	060100887	ARM, ORIFICE TUBE DRIVE
4	2	06000068	BEARING, FRUIT LIFT & ORIFICE ARM
5	5	004816100	WASHER, PLAIN N, 1/2", SS
6	1	004352572	SCREW, CAP HEX, 1/2-13 X 1 1/2, LEFT-HAND THREAD
7	1	004352571	SCREW, CAP HEX, 1/2-13 X 1-1/2, SS
8	1	004350212	SCREW, CAP HEX, 3/8-16 X 1-3/4, GR8

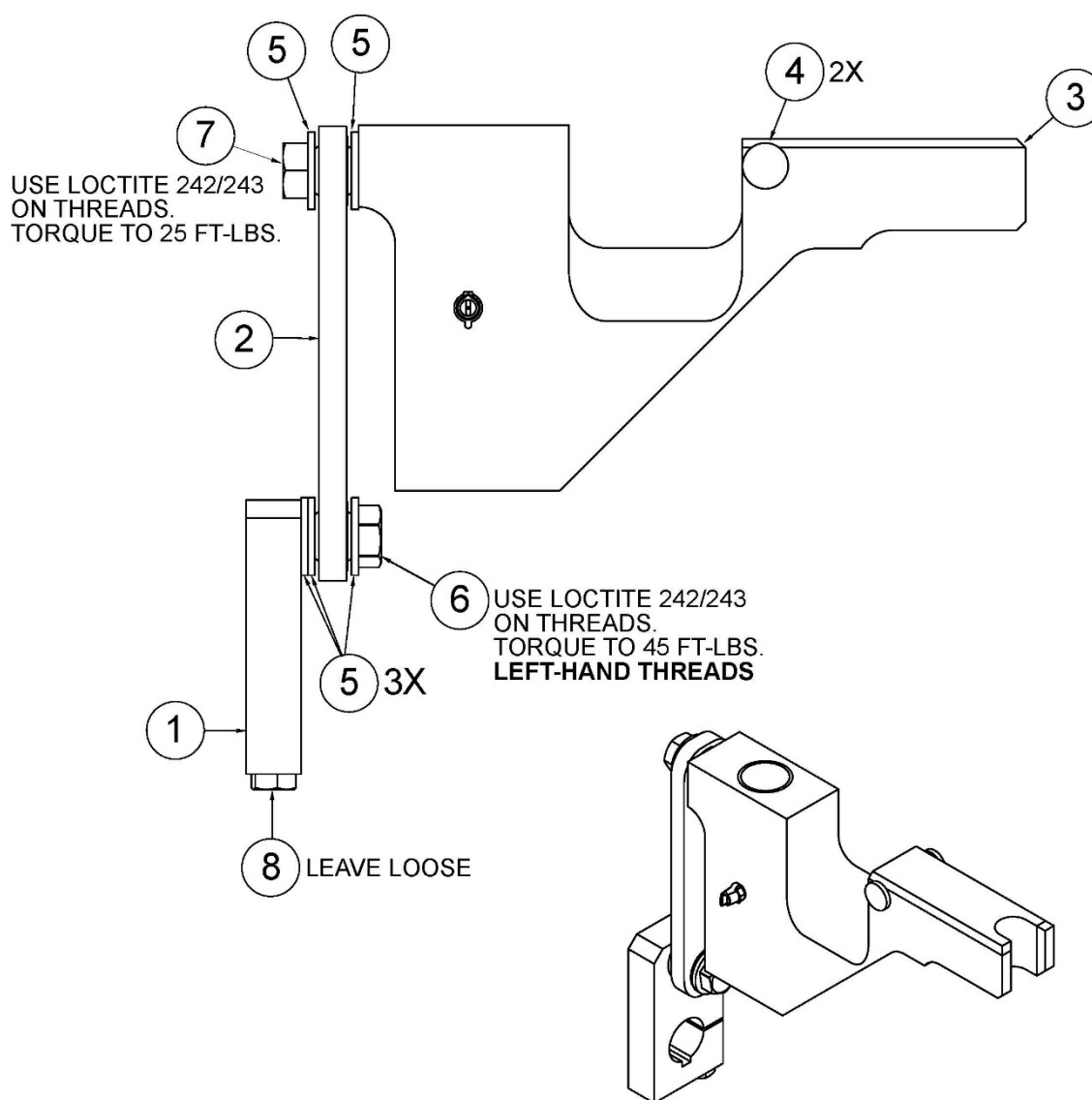

7. Hopper Motor Replacement

<u>Item</u>	<u>Qty</u>	<u>Part Number</u>	<u>Description</u>
1	1	060100843	FRUIT AGITATOR MOTOR ASSEMBLY
2	1	060100839	FRUIT AGITATOR, HOPPER
3	1	060100824	FRUIT AGITATOR ADAPTER, HOPPER
4	3	004816052	WASHER, PLAIN, #10, SS
5	2	004406123	SCREW ,SET, SOCKET,CUP POINT,10-24 X 3/16" LG,18-8SS
6	3	004352146	SCREW, CAP HEX, #10-32 X 3/8, 304SS

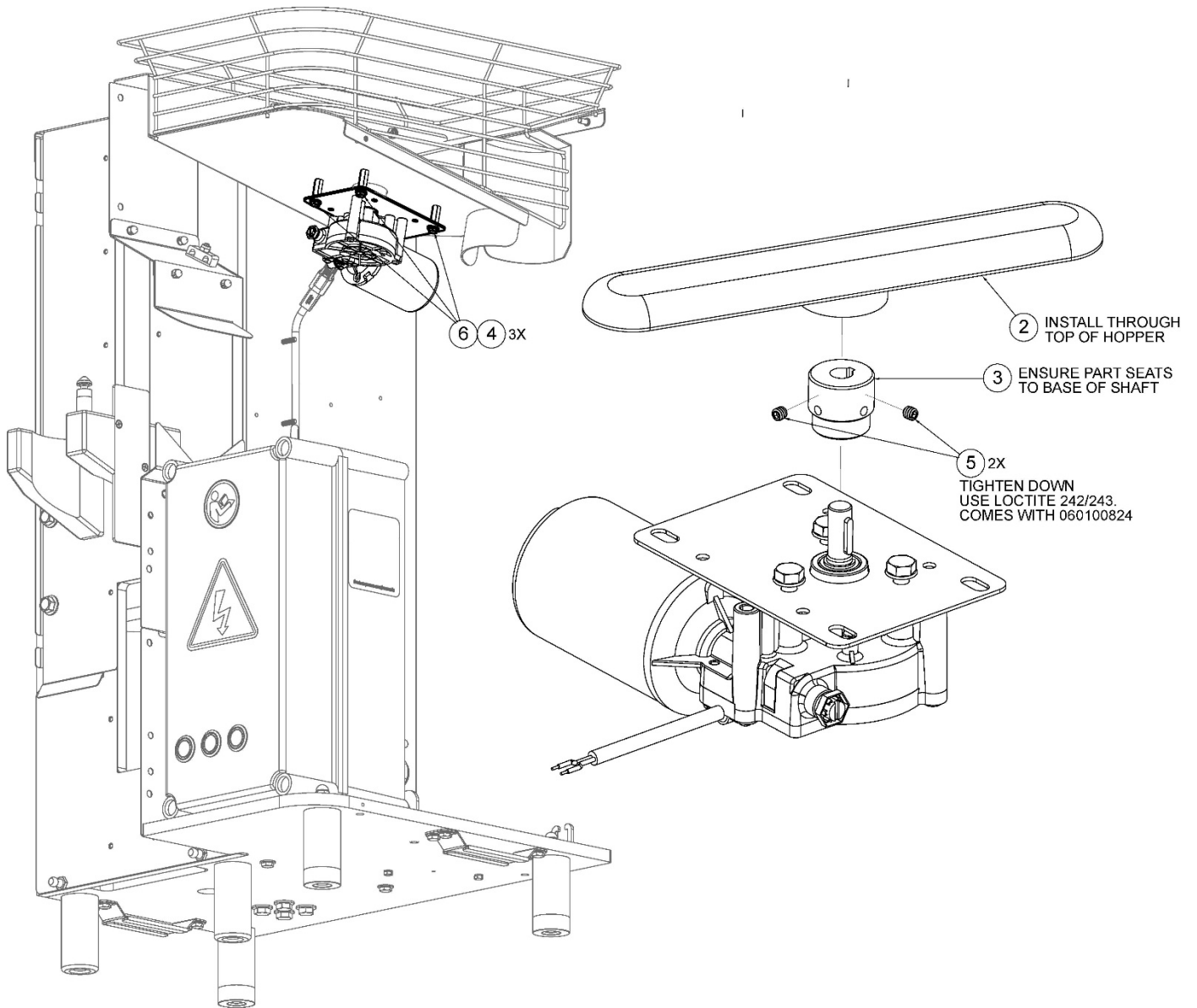

8. Motor Replacement

<u>Item</u>	<u>Qty</u>	<u>Part Number</u>	<u>Description</u>
1	1	060100946	MAIN GEARMOTOR, SPROCKET, ASSEMBLY
2	1	060100807	CHAIN GUIDE
3	1	060100780	TENSIONER, CHAIN
4	4	004816080	WASHER, PLAIN N, 3/8", 304SS
5	4	004806070	WASHER, LOCK, 3/8" REG, SS
6	4	004352406	SCREW,CAP,HEX, 3/8-16 X 1-3/4" LG, FULL THREAD, 304SS
7	4	004156074	NUT, HEX, S/L, LT, 3/8-16, 304SS

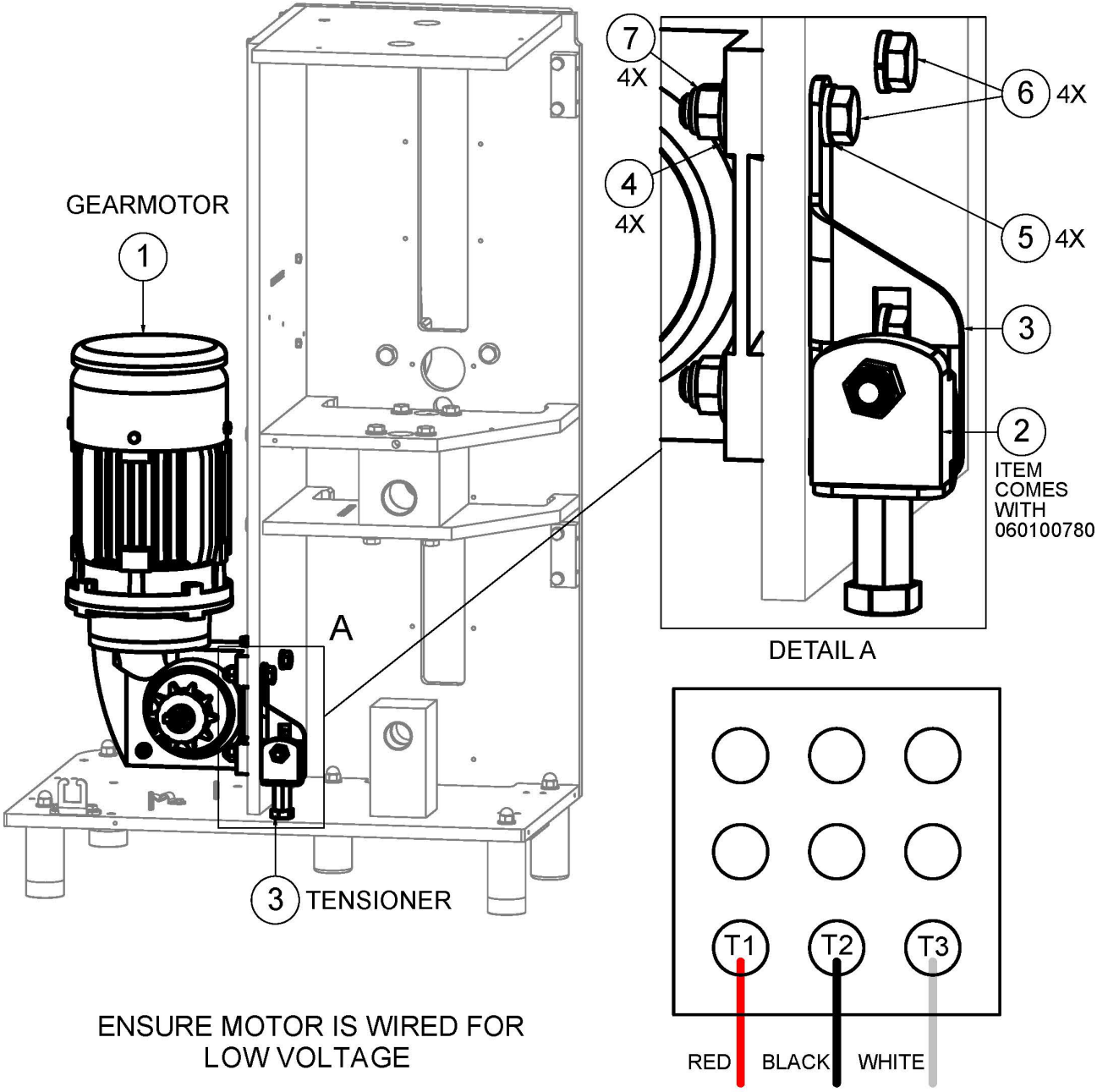

9. Safety Switch Replacement

<u>Item</u>	<u>Qty</u>	<u>Part Number</u>	<u>Description</u>
1	1	009998004	BIT, SPANNER INSERT, #8, 1/4" HEX SHANK
2	3	006200764	SAFETY SWITCH, INTERLOCK
3	4	004815126	METAL BONDED SEALING WASHER
4	4	004806030	WASHER, LOCK REG, #10, SS
5	18	004605037	SPACER, UNTHREADED, 5/16" OD X 3/16" LG, NYLON
6	2	004392211	SCREW, SPANNER, 8-32 X 1" LG, SS, TAMPER RESISTANT
7	8	004392197	SCREW, MACHINE, PAN HEAD, SPANNER TYPE, #8-32 X 1" LG, SS
8	2	004392175	SCREW, MACH, PAN, #8-32 X 3/4" LG, SPANNER, 304SS
9	8	004156166	NUT, ACORN, LOCK, DISTORTED THREAD, 8-32, 18-8SS
10	4	004156032	NUT, HEX, S/L, LT, 8-32, 304SS

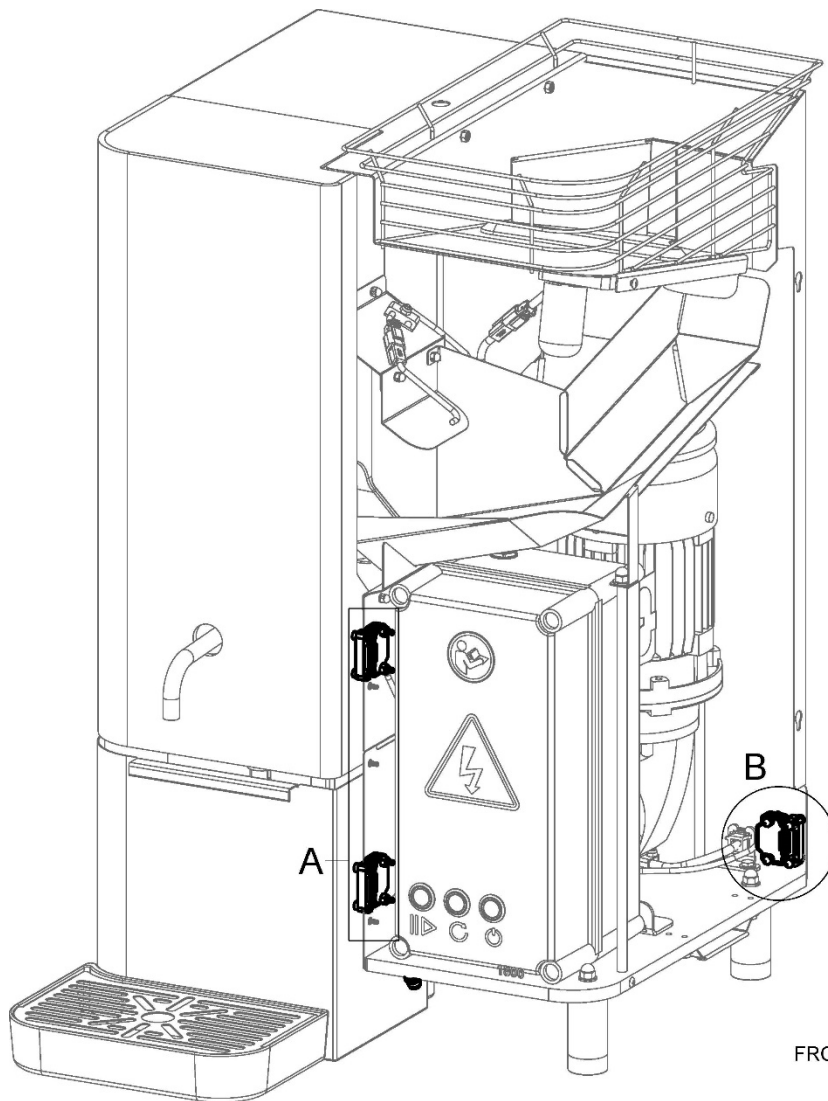

COVERS NOT SHOWN

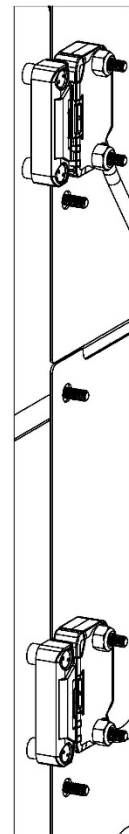

DETAIL A
FRONT SAFETY SWITCHES (2)

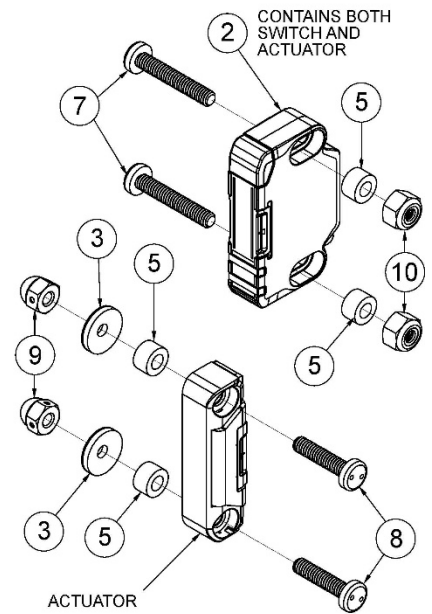

FRONT SAFETY SWITCH

Safety Switch Replacement

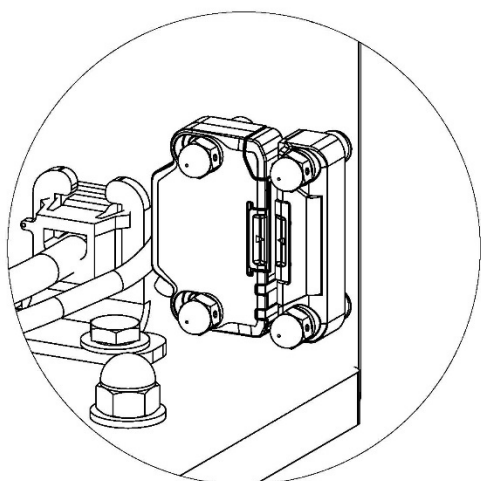

DETAIL B
SIDE SAFETY SWITCH

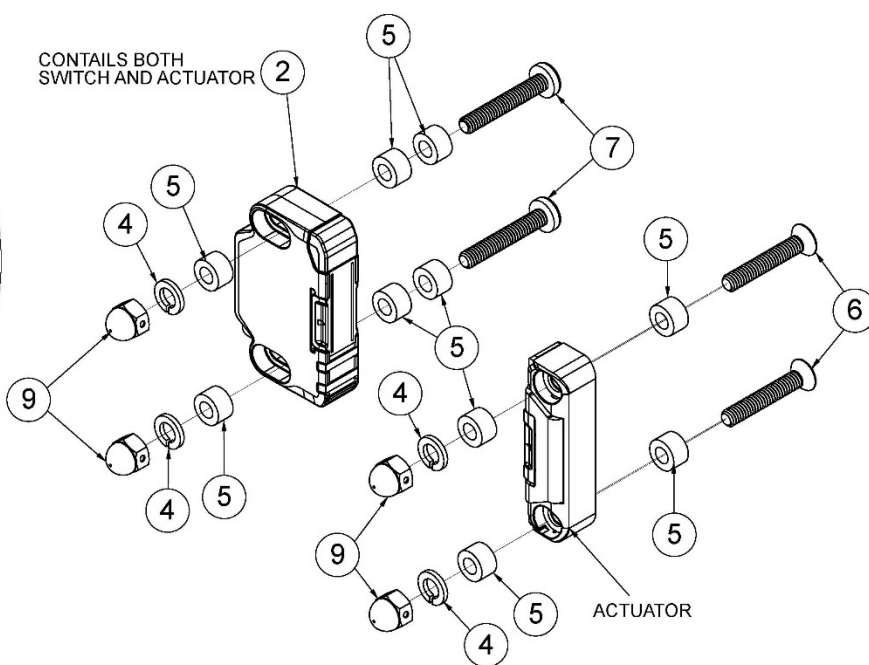

SIDE SAFETY SWITCH

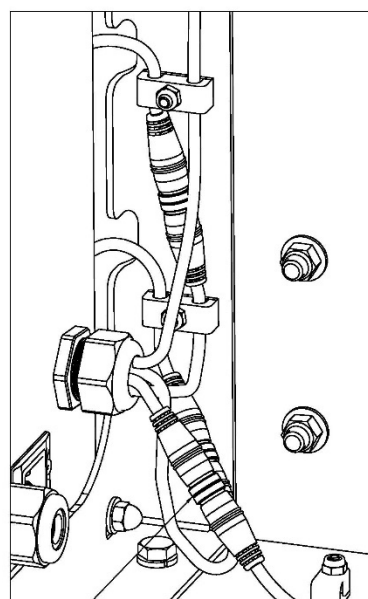
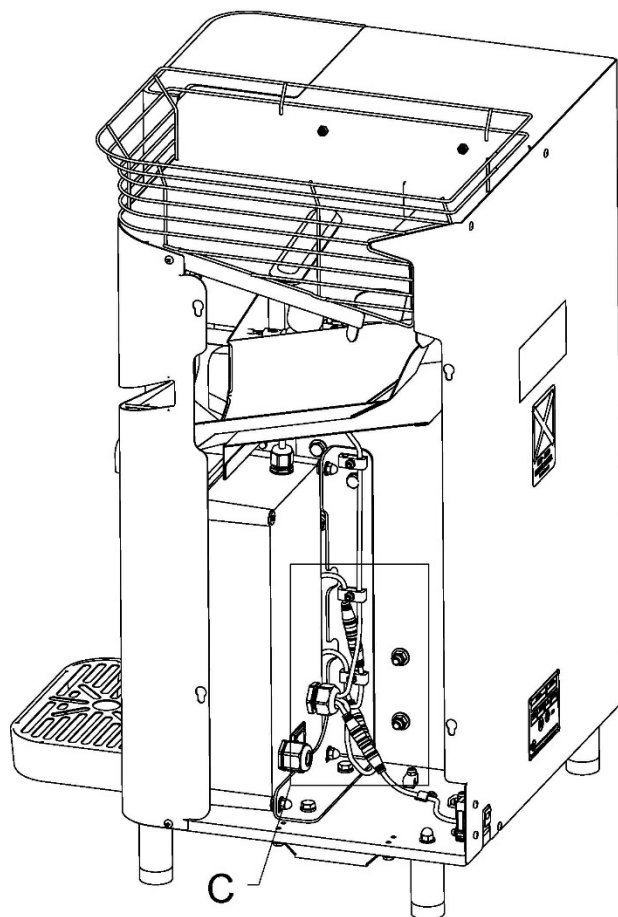

DETAIL C

UNSCREW CONNECTORS
TO REPLACE

10. Power Cord

<u>Item</u>	<u>Qty</u>	<u>Part Number</u>	<u>Description</u>
1	1	060100874	IEC PLUG, U.S., W/ STRAIN RELIEF, ASSEMBLY (US, CANADA, MEXICO, JAPAN)
2	1	060100912	IEC PLUG, CEE 7/7 , W/ STRAIN RELIEF, ASSEMBLY (MOST OF EUROPE, RUSSIA)
3	1	060100913	IEC PLUG, IRAM 2073, W/ STRAIN RELIEF, ASSEMBLY (AUSTRALIA, NEW ZEALAND, CHINA, ARGENTINA)
4	1	060100914	IEC PLUG, SEV 1011, W/ STRAIN RELIEF, ASSEMBLY (SWITZERLAND)
5	1	060100915	IEC PLUG, BS 1363, W/ STRAIN RELIEF, ASSEMBLY (UK, IRELAND, MALAYSIA, SINGAPORE)
6	1	060100931	IEC PLUG, CEI 23/50, W/ STRAIN RELIEF, ASSEMBLY (ITALY)
7	1	060100935	IEC PLUG, BS 546, W/ STRAIN RELIEF, ASSEMBLY (SOUTH AFRICA, HONG KONG)

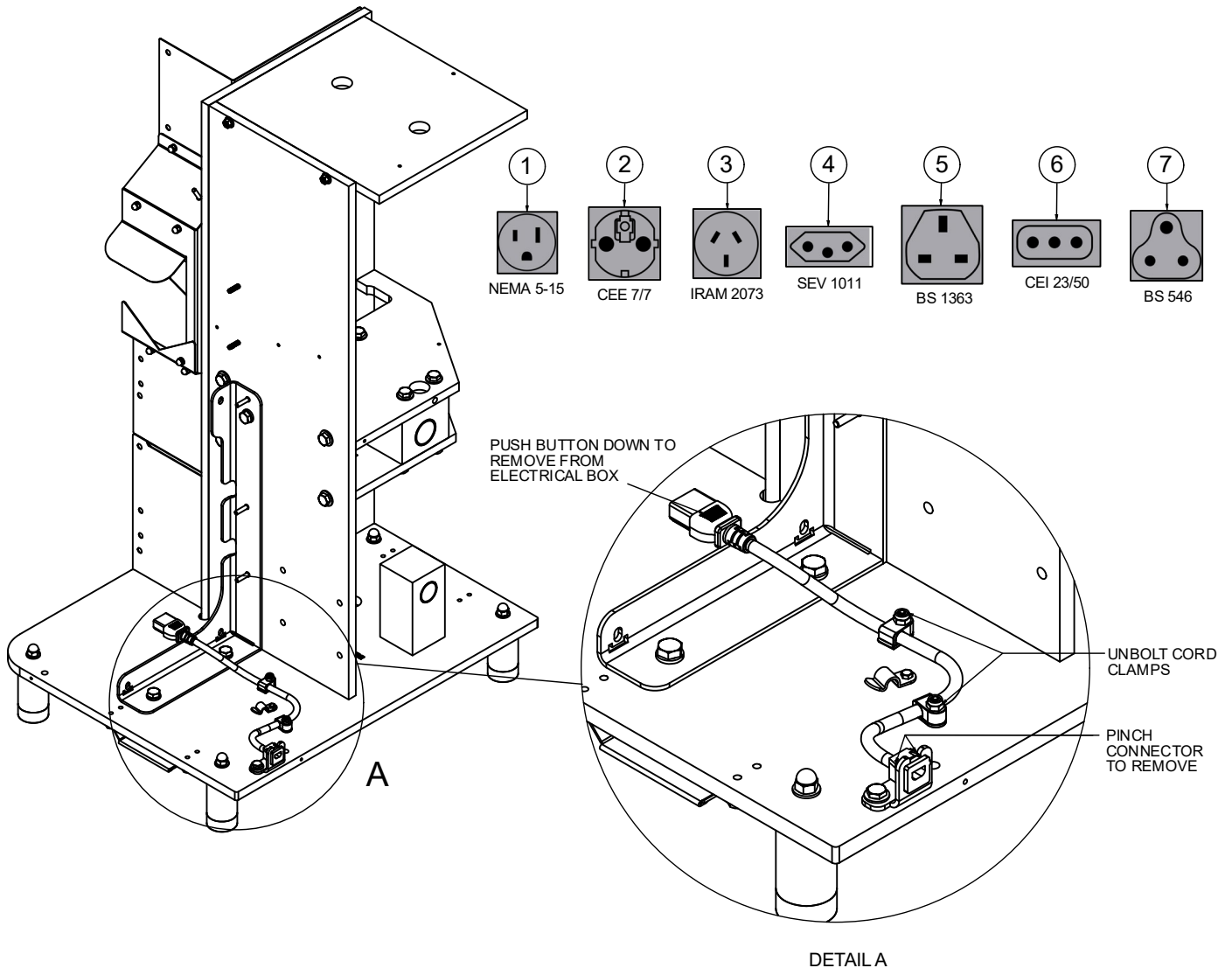

11. Electrical Panel Assembly, 115V (p/n 060100736)

Item	Qty	Part Number	Description
1	1	060100927	RUN SWITCH, ASSEMBLY, BLUE LED, 25MM BUTTON, W/ CONNECTOR
2	1	060100926	REVERSE SWITCH, ASSEMBLY, RED LED, 25MM BUTTON, W/ CONNECTOR
3	1	060100925	POWER SWITCH, ASSEMBLY, GREEN LED, 25MM BUTTON, W/ CONNECTOR
4	1	060100796	DELTA VFD, 115V, PROGRAMMED
5	1	006281383	POWER SUPPLY, 85-264VAC IN X 24VDC OUT, 3.125A, 75W
6	1	006080392	RELAY, SPADE-TERMINAL, SPDT, 24VDC, 5-TERMINALS
7	1	006020378	CIRCUIT BREAKER, 1-POLE, 2A, 250 VAC, 28VDC
8	1	006020234	CIRCUIT BREAKER, MOTOR PROTECTION, 10A
9	4	004385195	SCREW, CROSS HEAD, 100MM X 100MM X 10MM, PHILIP

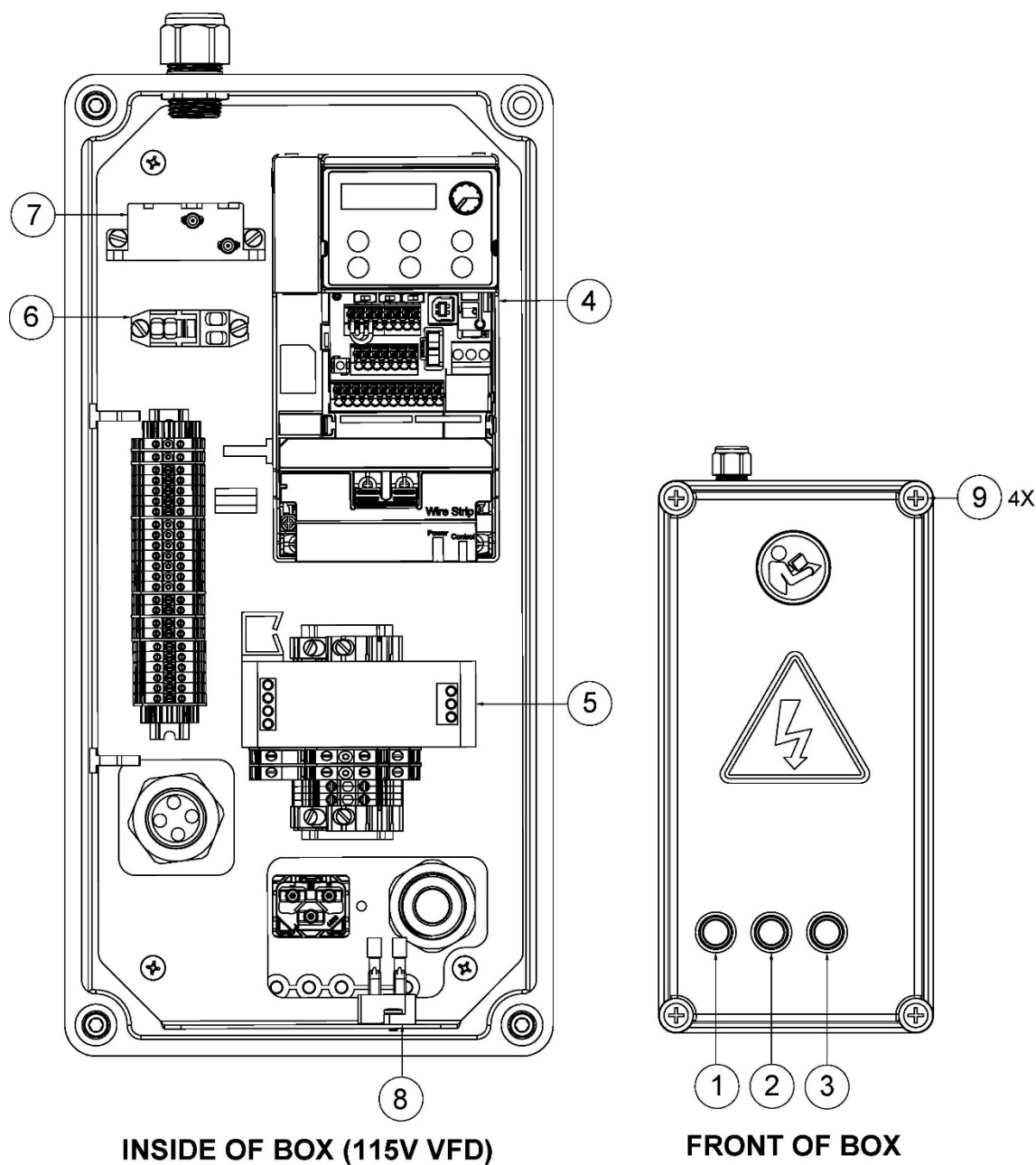

12. Electrical Wiring Diagram, 115V (p/n 060100736)

**ELECTRICAL WIRING DIAGRAM
115V**

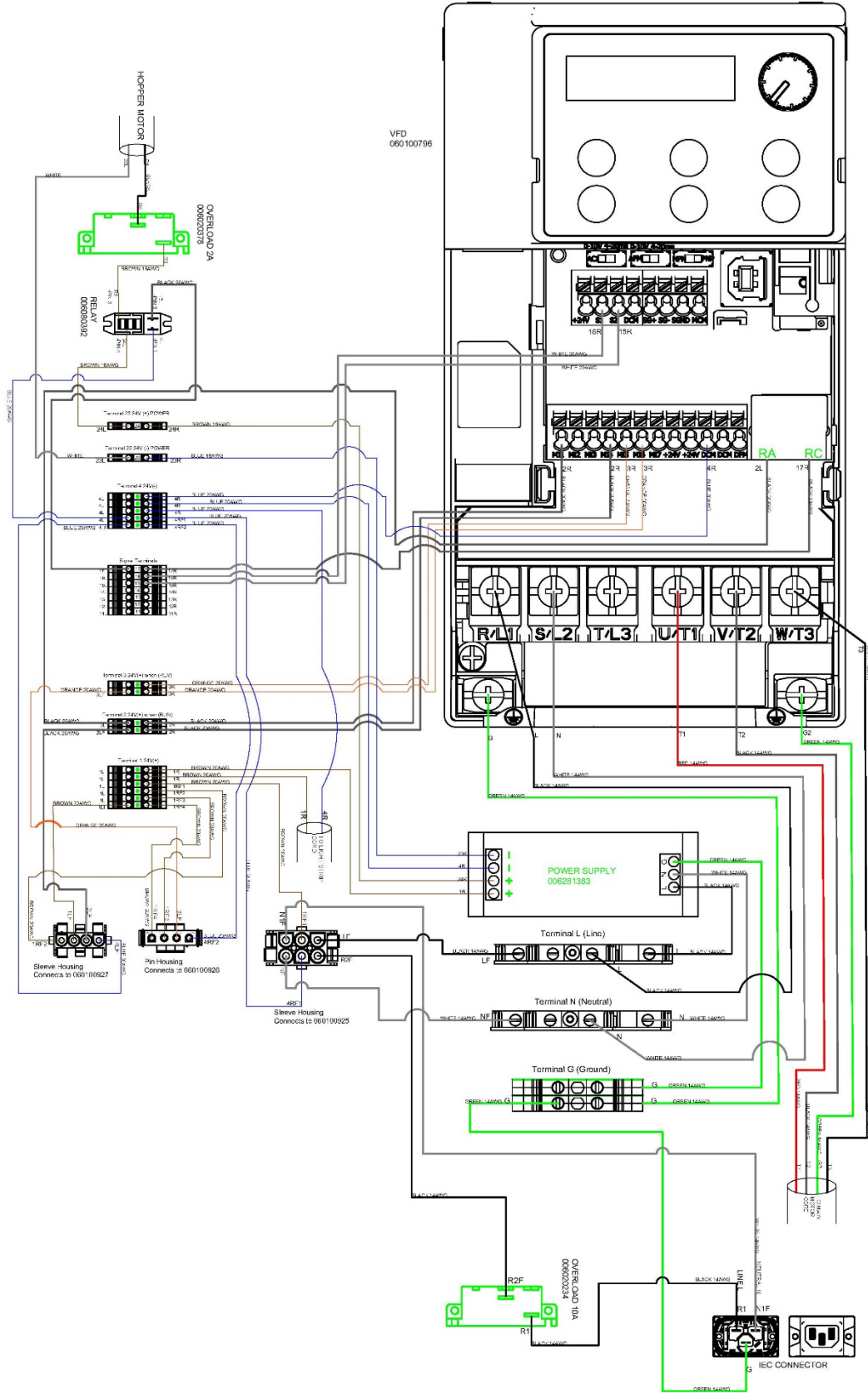

13. Electrical Panel Assembly, 230V (p/n 060100918)

Item	Qty	Part Number	Description
1	1	060100927	RUN SWITCH, ASSEMBLY, BLUE LED, 25MM BUTTON, W/ CONNECTOR
2	1	060100926	REVERSE SWITCH, ASSEMBLY, RED LED, 25MM BUTTON, W/ CONNECTOR
3	1	060100925	POWER SWITCH, ASSEMBLY, GREEN LED, 25MM BUTTON, W/ CONNECTOR
4	1	060100917	DELTA VFD, 230V, PROGRAMMED
5	1	006281383	POWER SUPPLY, 85-264VAC IN X 24VDC OUT, 3.125A, 75W
6	1	006080392	RELAY, SPADE-TERMINAL, SPDT, 24VDC, 5-TERMINALS
7	1	006020378	CIRCUIT BREAKER, 1-POLE, 2A, 250 VAC, 28VDC
8	2	006020251	CIRCUIT BREAKER, MOTOR PROTECTION, 5A (230V ONLY)
9	4	004385195	SCREW, CROSS HEAD, 100MM X 100MM X 10MM, PHILIP
10	1	006270335	FILTER, POWER LINE, 1 PH, 1 ST, 16A, 250VAC, QUICK CONNECT, FLG MOUNT

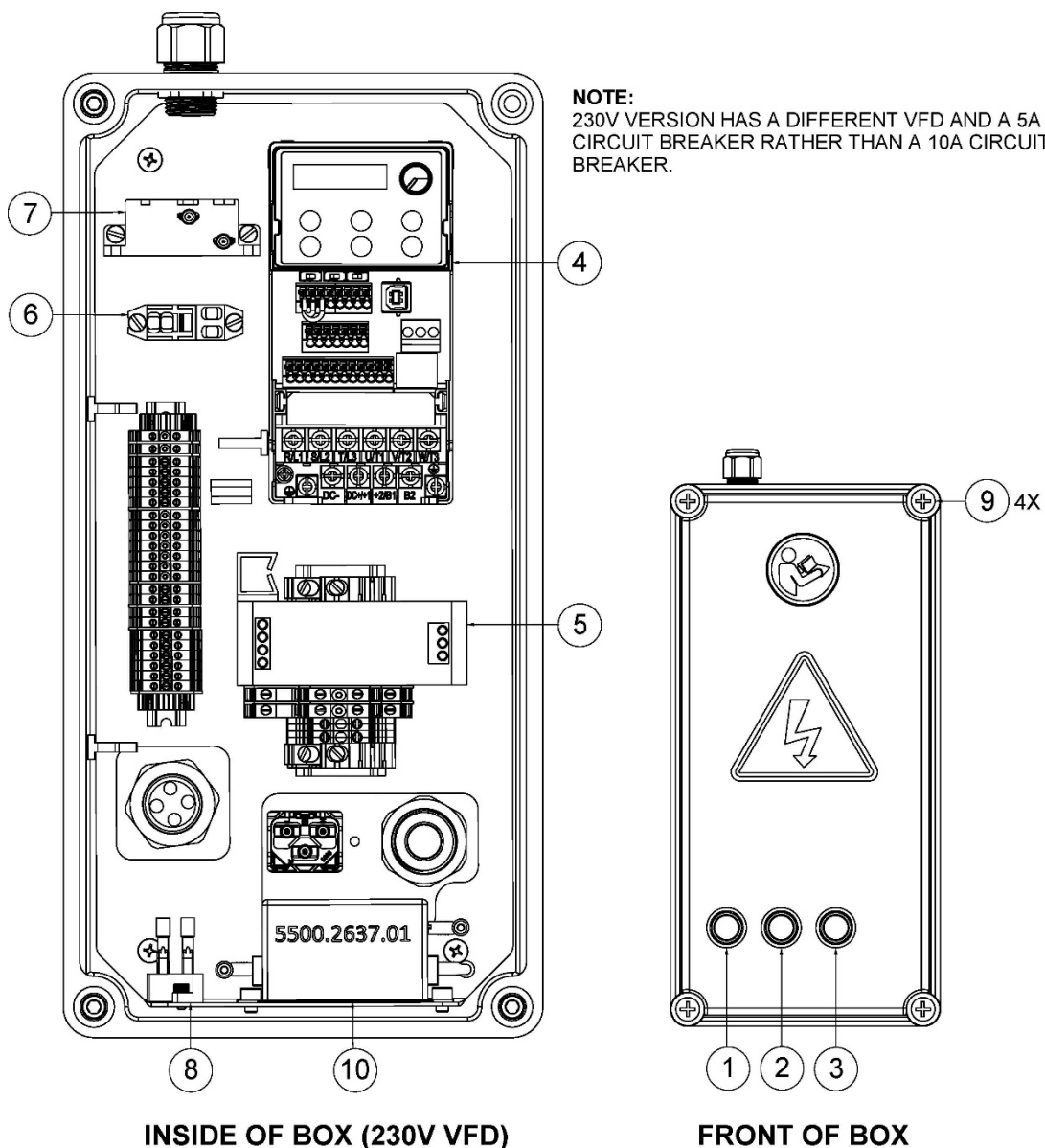

14. Electrical Wiring Diagram, 230V (p/n 060100918)

**ELECTRICAL WIRING DIAGRAM
230V**

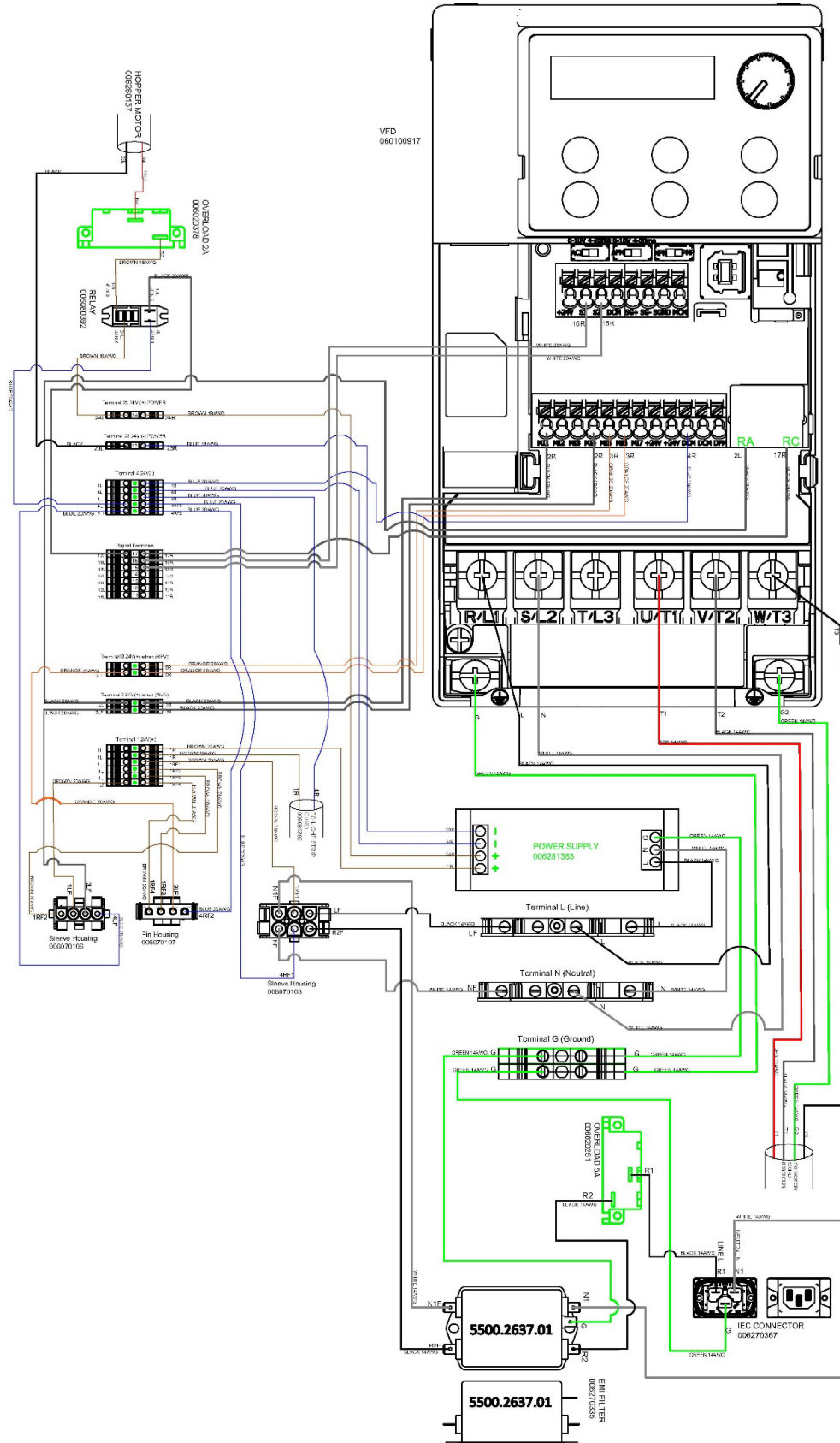

15. Waste Bin

Item	Qty	Part Number	Description
1	1	060100837	WASTE BIN, WELDMENT, WITH DRIP TRAY PINS
2	2	007160036	GROMMET, HOLE, 3/8" ID, 11/16" OD, FOR 1/16" MAT, BUNA-N RUBBER
3	2	004605037	SPACER, UNTHREADED, 5/16" OD X 3/16" LG, NYLON
4	2	004392175	SCREW, MACH, PAN, #8-32 X 3/4" LG, 304, SPANNER
5	2	004156166	NUT, ACORN, LOCK, DISTORTED THREAD, 8-32, 18-8SS
6	2	004815126	METAL BONDED SEALING WASHER

ALWAYS REINSTALL SAFETY SWITCH ACTUATOR WHEN REPLACING DOOR. OTHERWISE, MACHINE WILL NOT RUN.
NEVER REMOVE ACTUATOR FROM DOOR TO DEFEAT SAFETY SWITCH. THIS COULD RESULT IN INJURY AND WILL VOID WARRANTY.
 TO REMOVE SPANNER SCREWS, ITEM 00998004 IS REQUIRED

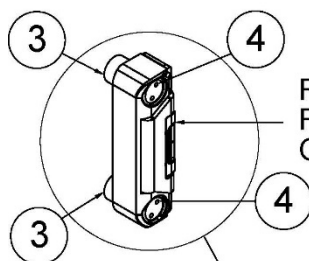

REFER TO DIAGRAM FOR REPLACEMENT OF SAFETY SWITCH

DETAIL A

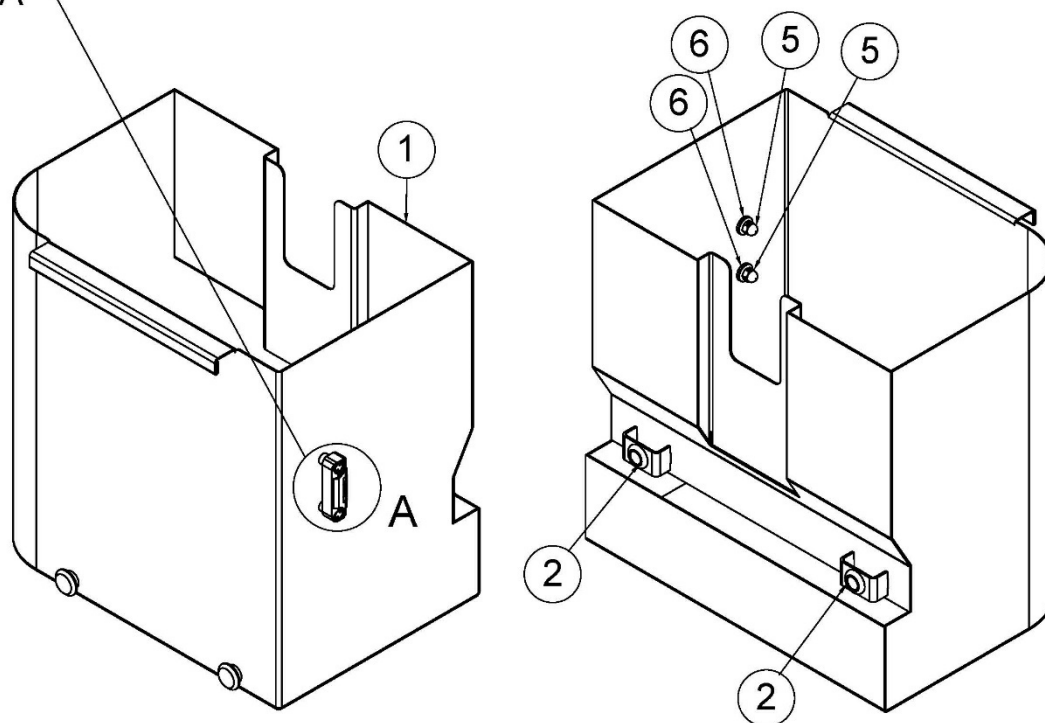

16. Cover Assembly

<u>Item</u>	<u>Qty</u>	<u>Part Number</u>	<u>Description</u>
1	1	060100911	DECAL, "BROUGHT TO YOU BY +JBT MAREL", 0.333" X 4.712" LG
2	1	060100907	DECAL, "1800", 1" X 0.375"
3	1	060100902	DECAL, BUTTON SYMBOLS, 0.75" X 4" LG
4	1	060100901	DECAL, "FRESH 'N SQUEEZE". 1.5" X 8"
5	1	060100893	FRONT PANEL, W/ BUTTON CUTOUTS, SAFETY ORANGE COATED
6	1	060100873	ACCESS DOOR ASSEMBLY, W/SNAP IN HANDLE, W/ KEYHOLE PINS
7	1	060100823	HOPPER, ASSEMBLY, WELDMENT
8	1	006090245	PLUG, SNAP-IN, 11/16" HOLE, NYLON
9	14	004401023	SCREW, PHILIP, X-TRA WIDE, 8-32" THREAD, 3/8" LG, PASSV, SS
10	2	004355378	SCREW, HEX, FLANGED, 1/4-20 X 1" LG

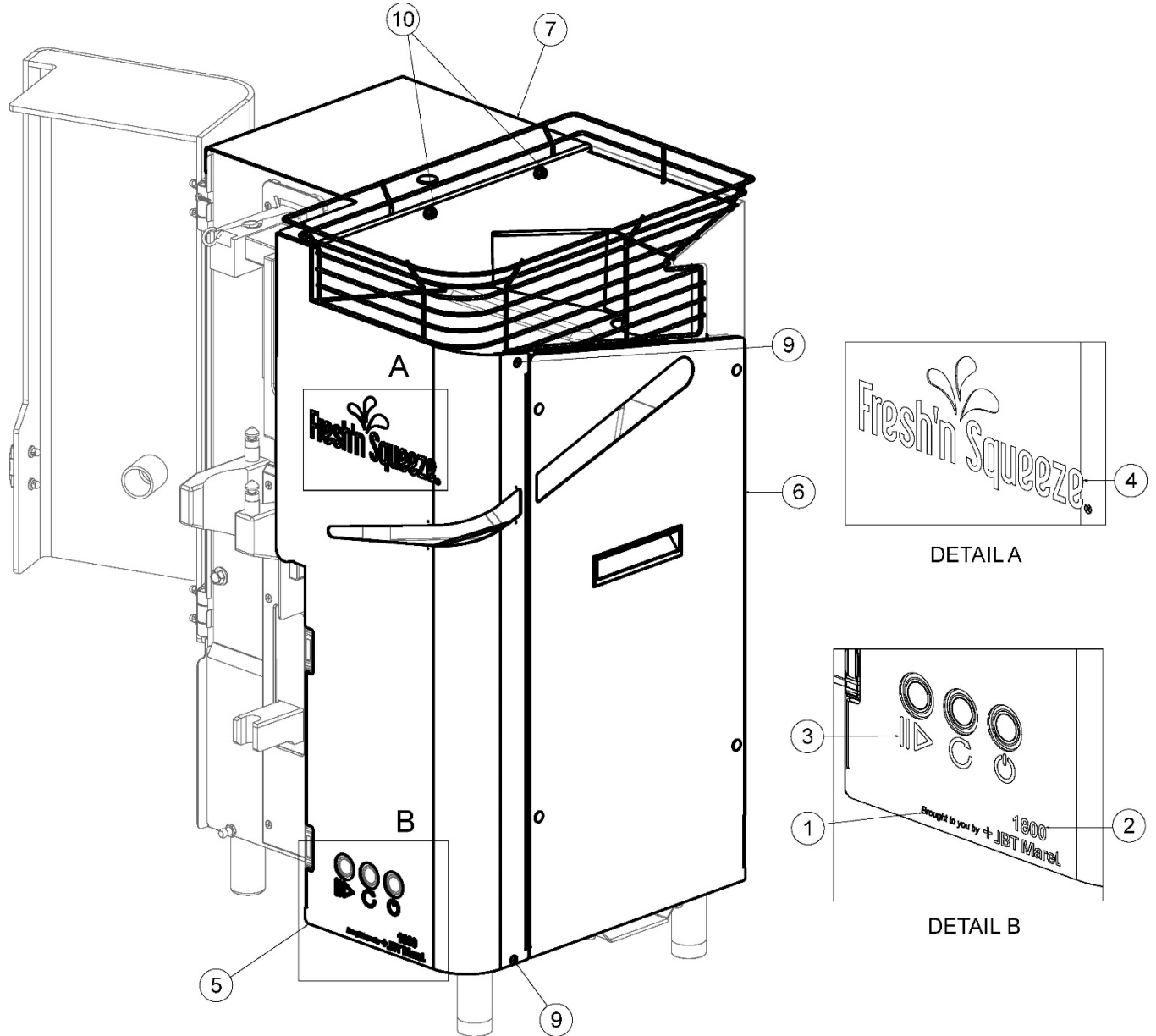

Cover Assembly

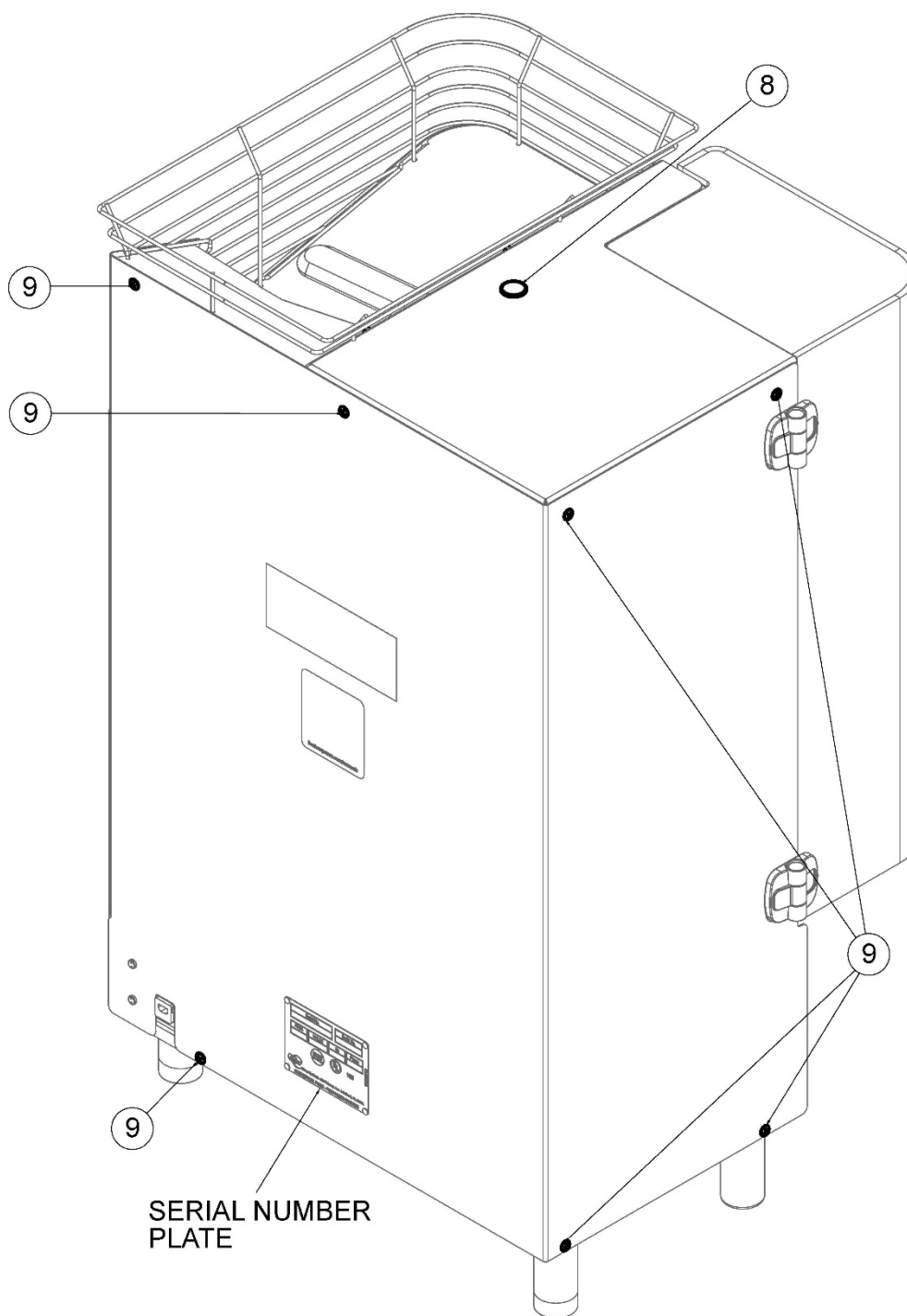

NOTE:

BACK COVER NOT SOLD BECAUSE MACHINE'S SERIAL NUMBER PLATE IS ATTACHED.
IF BACK COVER IS DAMAGED, CONTACT JBT MAREL SERVICE FOR REPLACEMENT.

17. Light Replacement

<u>Item</u>	<u>Qty</u>	<u>Part Number</u>	<u>Description</u>
1	1	060100868	GREEN, LED, RING LIGHT, FRONT PANEL
2	1	060100857	BACK PLATE, LED LIGHT RING

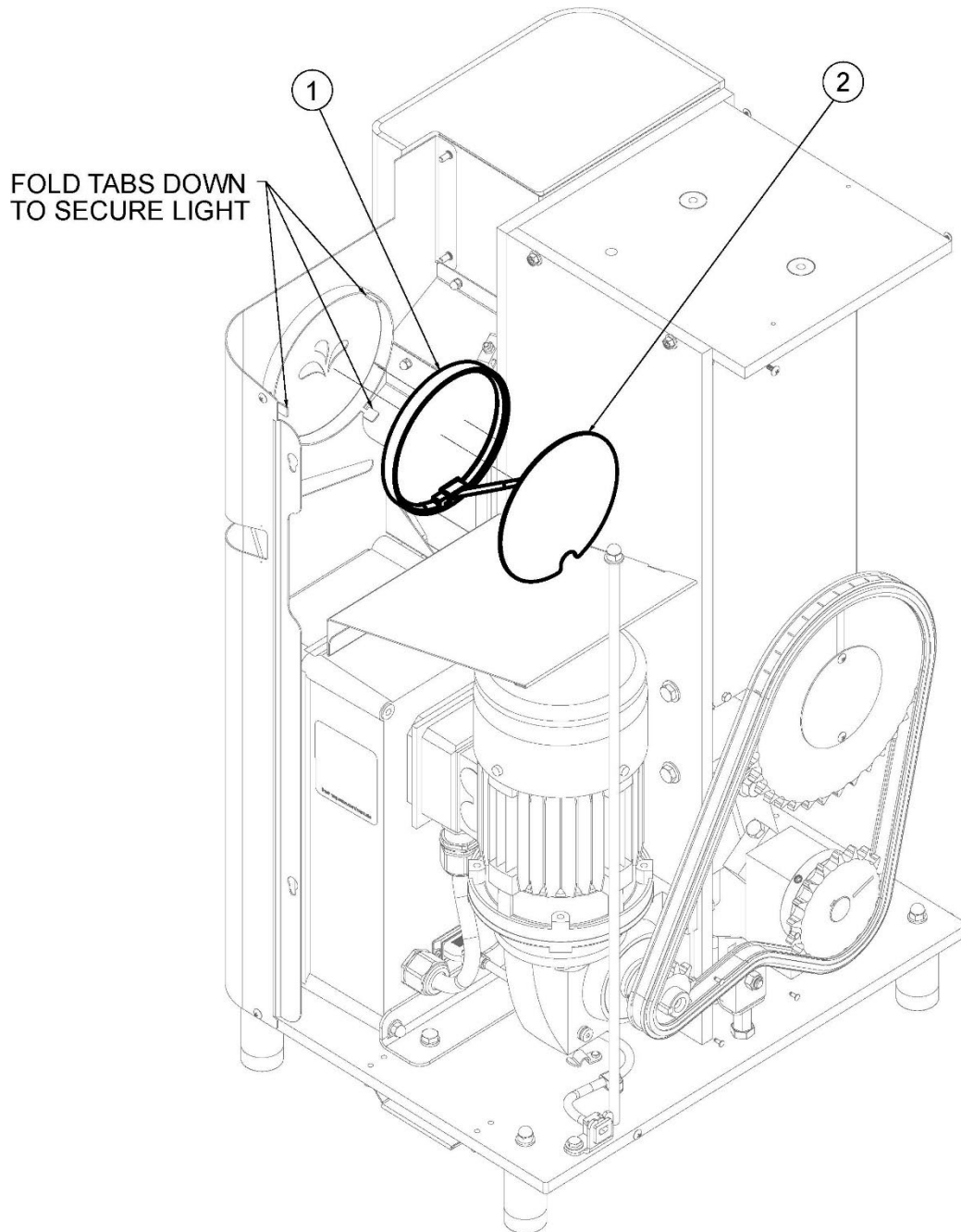

18. Feet Replacement

<u>Item</u>	<u>Qty</u>	<u>Part Number</u>	<u>Description</u>
1	2	060100908	FOOT, FRONT LEG, ASSEMBLY, BOLTED
2	3	060100875	RUBBER PAD FOOT, LEG, ASSEMBLY, BOLTED

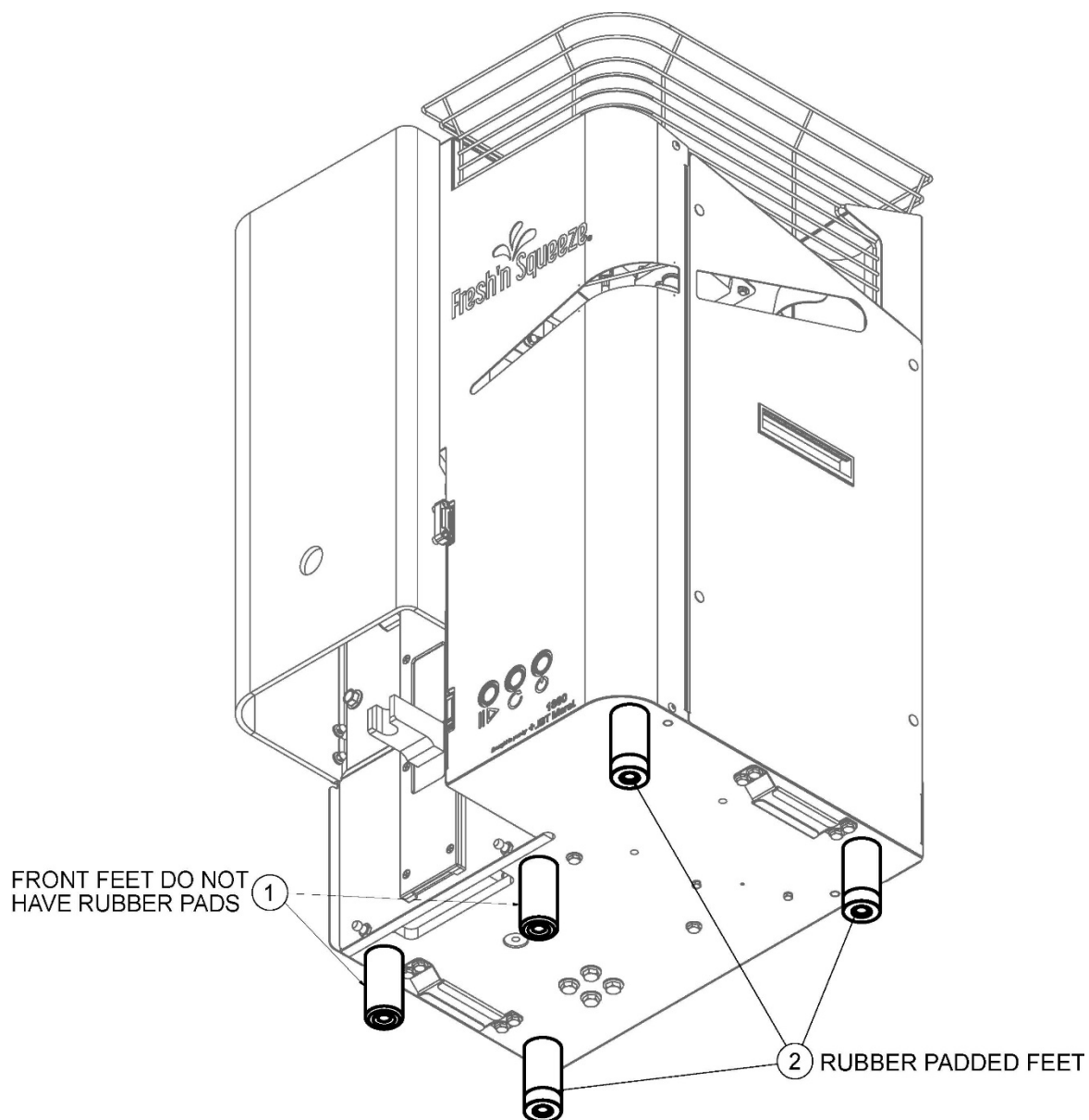

MACHINE WILL HAVE TO BE LIFTED IN ORDER TO REMOVE FEET.
ENSURE MACHINE IS ADEQUATELY SUPPORTED.

**CAUTION: DO NOT LIFT MACHINE BY YOURSELF.
ALWAYS USE TWO OR MORE PEOPLE.**