

# KOLD-DRAFT®

## Installation, Operation, Technical Service and Replacement Parts Manual

Ice Cube Makers - GT36x, GT56x, GB56x, GB106x

Stacking Instructions - Multiple GB56x or GB106x

Ice Cube Crushers - T27x, T28x

Pre-charged Remote Air-Cooled Condenser - RC214APV, RC314APV  
SC200



GT36x



GT56x



GB56x



GB106x

### KOLD DRAFT INTERNATIONAL

1525 East Lake Road  
Erie, PA 16511-1088 U.S.A.

(800) 840-9577

FAX: (800) 548-9392

www.kold-draft.com

May 5, 2017



# KOLD-DRAFT

Installation, Operation, Technical Service Specifications and Replacement Parts Manual

Ice Cube Makers

GT36x, GT56x GB56x, GB106x

Stacking Instructions

Multiple GB56x or Multiple GB106x

Ice Cube Crushers

T27xT28x

Pre-charged Remote Air-Cooled Condenser

RC214APV (For GB/GT56xR) RC314APV (For GB106xR)

Copyright 2015 KOLD DRAFT INTERNATIONAL

Unauthorized reproduction of this manual is freely permitted for all purposes except for monetary gain.

It is not guaranteed that this service manual is up to date, technically correct, complete, or free from writing problems or that the product is free from minor flaws or that it meets the needs of the customer.

May 2017

# Table of Contents

- SAFETY INFORMATION ..... 1
- ICE MAKER IDENTIFICATION ..... 2
  - Serial Number Plate Location ..... 2
  - Date Code Key ..... 2
  - Model Number Key ..... 3
- ICE CUBER Installation ..... 4
  - What's in the box ..... 4
  - Required Tools ..... 4
  - Pre-Install Checklist ..... 5
  - Additional Pre-install Information for Cooling Tower Applications (L models) ..... 7
- ASSEMBLY ..... 8
  - Unpacking ..... 8
  - Assembly Procedure ..... 8
- INITIAL START PROCEDURE ..... 10
- ICE MACHINE CLEANING PROCEDURE ..... 11
- SPECIFICATIONS ..... 12
  - Machine Capacities ..... 12
  - Electrical Use and Machine Dimensions/Weight ..... 13
  - Water Fill Levels, Cycle Times and Harvest Weights ..... 14
  - Cube Information ..... 14
  - Typical Refrigerant Operating Pressures ..... 14
- COMPONENTS ..... 15
  - Mechanical Components ..... 15
  - GB106x Series Unique Components ..... 19
    - Controller ..... 20
- ERROR-CODE TROUBLESHOOTING ..... 23
- SEQUENCE OF OPERATION ..... 28
  - Ice Making Sequence ..... 28
  - Ice Bin Full/Cleaning Mode ..... 29
  - Description of Each Process ..... 29
    - Fill ..... 29
    - Freeze ..... 29
    - Lower ..... 30
    - Harvest ..... 30
    - Raise ..... 30
    - Ice Bin Full ..... 30
    - Cleaning Mode ..... 30
    - Water Plate Closure Problems ..... 30
      - Shutdown-High Pressure ..... 30
- START METHODS ..... 31
  - Ice Making Mode Start Up ..... 31
  - Cleaning Mode Start Up ..... 31
- GT36X, GT56X, GB56X WIRING DIAGRAM ..... 32
- GB1064 A & L WIRING DIAGRAM ..... 33
- GB106XR WIRING DIAGRAM ..... 34

COMPRESSOR TEST PROCEDURE .....	35
Test Procedure for a Short Circuit to Ground (Ground Fault) .....	36
Test Procedure for Continuity And Proper Resistance .....	36
Test Procedure for Compressor Electrical Components.....	37
Testing The Run Capacitor: .....	37
Testing The Start Capacitor: .....	37
Additional Service Information .....	38
WATER PLATE REPLACEMENT .....	39
WATER PLATE ALIGNMENT .....	40
WATER PLATE UP/DOWN POSITION AND ADJUSTMENT .....	41
ACTUATOR MOTOR KIT APPLICATION LIST .....	42
PROBE TEST PROCEDURE.....	43
INSTRUCTIONS FOR GB1064 WATER FILL ADJUSTMENT .....	44
TROUBLESHOOTING .....	46
PARTS DIAGRAMS .....	52
GT36x Parts.....	53
GT56x Parts.....	54
GB56x Parts.....	56
GB106x Parts.....	58
PARTS LIST .....	61
ACTUATOR MOTOR KIT APPLICATION LIST .....	64
STACKING INSTRUCTIONS .....	65
ICE CUBE CRUSHERS - T27X.....	68
ICE CRUSHER SAFETY INFORMATION.....	69
ICE CRUSHER INSTALLATION .....	70
Pre-Install Checklist .....	70
Assembly/Installation .....	71
Initial Start-Up .....	74
ICE CRUSHER OPERATION.....	75
ICE CRUSHER CLEANING PROCEDURE .....	76
ADJUSTMENT AND LUBRICATION.....	76
WIRING DIAGRAM .....	77
PRE-CHARGED REMOTE AIR COOLED CONDENSER .....	78
PRE-CHARGED REMOTE AIR COOLED INSTALLATION .....	79
Pre-Install checklist .....	79
Installation.....	80
Specifications.....	80
Minimum Total Charge Required .....	80
Electrical Information .....	82
Removing From Service .....	82
SC200 Series Ice Machine.....	83

## **ICE CUBER-SAFETY INFORMATION**

Special attention should be given to potential hazard labeling on the equipment and the signal words and symbols that are used throughout this manual. They may also be used to alert against unsafe practices

Note: Note is used to notify personnel of installation, operation or maintenance information which is important, but not a cause of personal injury or property damage.

**Warning:** Indicates a potentially hazardous situation that may result in minor or moderate injury. The situation may also cause minor damage to the machine

**Caution:** Indicates a potentially hazardous situation that could cause serious injury or death. The situation may also critically damage the machine

**DANGER:** Indicates a potentially hazardous situation that could cause serious injury or death. The situation may also critically damage the machine

### Note:

- Check for freight damage before proceeding with the equipment installation. Be sure to inspect the equipment carefully for any damage that may not have been evident on the outside of the carton. Contact the freight carrier immediately to report any damage and file a claim.
- Read the entire manual before installing, operating or servicing the machine
- To ensure optimal efficiency and productivity follow these installation instructions exactly.
- All machines have been tested and adjusted for correct performance at the factory.
- Knowledge of proper installation and service procedures is essential for the safe operation and maintenance of KOLD-DRAFT equipment. Refer all installation and service work to qualified technicians.
- This equipment must be installed in compliance with the applicable federal, state/province, and/or local plumbing, electrical, and health/sanitation codes and requirements.
- Always disconnect the power supply before servicing the equipment or when the equipment will not be used for a period of time. Some circuits remain energized when the machine is switched off.
- Never operate equipment that has been damaged or does not have all the protective covers in place.
- Never operate equipment that has been altered from the original KOLD-DRAFT specifications.
- Use of non-approved parts when servicing KOLD-DRAFT equipment will void the equipment warranty.

**Warning:** Use only genuine KOLD-DRAFT replacement parts, Use of non-approved parts when servicing KOLD-DRAFT equipment may create a safety hazard, cause equipment damage, property damage and will void the warranty.

# ICE MAKER IDENTIFICATION

## Serial Number Plate Location

See the following for the location of the serial number plate.

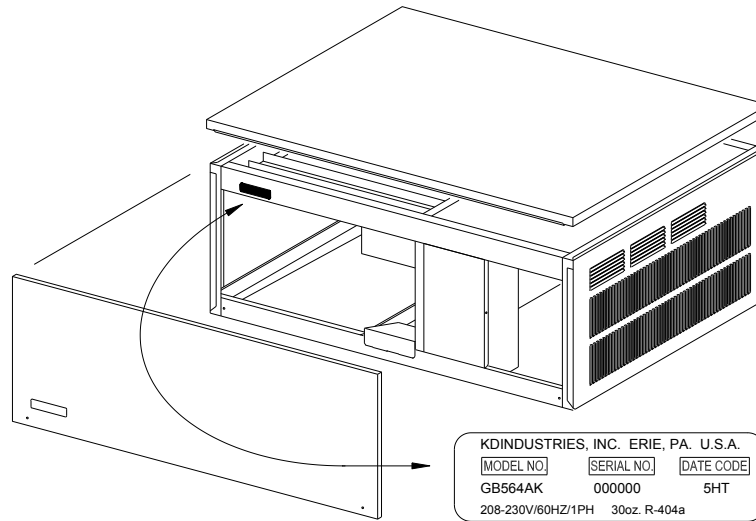

Note: A complete model number and date code are essential for the accurate selection of replacement parts. The sticker will be applied to the front of the top cross member of the machine

## Date Code Key

<b>YEAR KEY</b>			
<b>5K = 2000</b>	<b>6K = 2010</b>	<b>7K = 2020</b>	<b>8K = 2030</b>
<b>5A = 2001</b>	<b>6A = 2011</b>	<b>7A = 2021</b>	<b>8A = 2031</b>
<b>5B = 2002</b>	<b>6B = 2012</b>	<b>7B = 2022</b>	<b>8B = 2032</b>
<b>5C = 2003</b>	<b>6C = 2013</b>	<b>7C = 2023</b>	<b>8C = 2033</b>
<b>5D = 2004</b>	<b>6D = 2014</b>	<b>7D = 2024</b>	<b>8D = 2034</b>
<b>5E = 2005</b>	<b>6E = 2015</b>	<b>7E = 2025</b>	<b>8E = 2035</b>
<b>5F = 2006</b>	<b>6F = 2016</b>	<b>7F = 2026</b>	<b>8F = 2036</b>
<b>5G = 2007</b>	<b>6G = 2017</b>	<b>7G = 2027</b>	<b>8G = 2037</b>
<b>5H = 2008</b>	<b>6H = 2018</b>	<b>7H = 2028</b>	<b>8H = 2038</b>
<b>5J = 2009</b>	<b>6J = 2019</b>	<b>7J = 2029</b>	<b>8J = 2039</b>
<b>MONTH KEY</b>			
<b>M = JANUARY</b>	<b>R = APRIL</b>	<b>U = JULY</b>	<b>X = OCTOBER</b>
<b>N = FEBRUARY</b>	<b>S = MAY</b>	<b>V = AUGUST</b>	<b>Y = NOVEMBER</b>
<b>P = MARCH</b>	<b>T = JUNE</b>	<b>W = SEPTEMBER</b>	<b>Z = DECEMBER</b>
<b>EXAMPLE</b>			
<b>5HS = MAY, 2008</b>			

## Model Number Key

Note: Model numbers mentioned in this manual that look like GB56x are used to refer to general families of machines. The “x” could stand for any combination of a machine’s electrical characteristics, condenser type and cube size

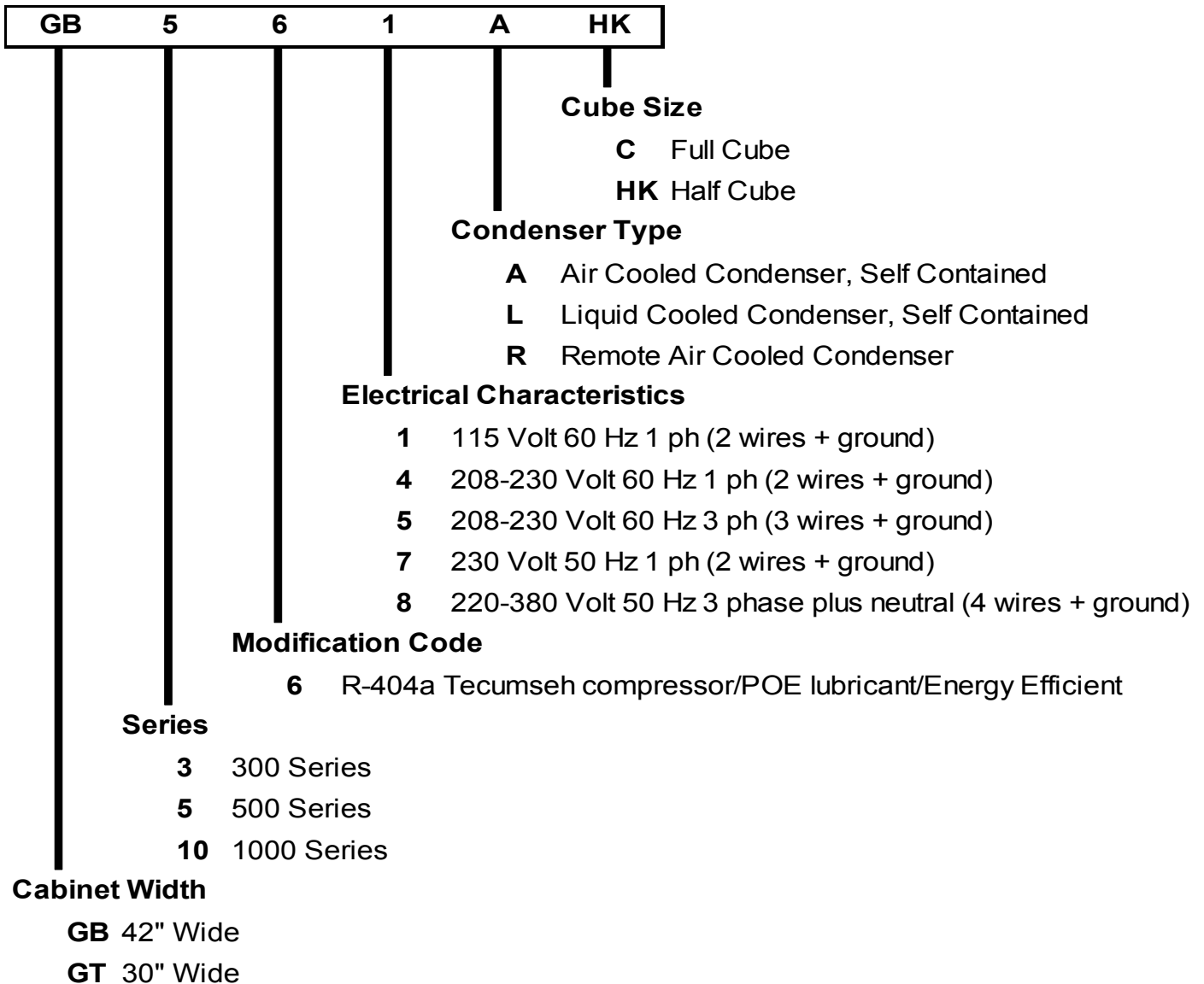

## **ICE CUBER INSTALLATION**

### ***Warning:***

- Do not operate equipment that has been damaged.
- Refer all maintenance to qualified personnel.
- Instruct all personnel in the proper use of the equipment.
- Clean up any liquid spills immediately.
- Always install equipment on a stable and level surface.
- All models are intended for indoor use only. Do not install the equipment in unprotected outdoor areas.
- Always securely attach individual component sections together. (Bins, Bagging Machines, Dispensers, Crushers, Ice Machines etc.)
- Do not install the equipment in wet areas.
- Do not locate the equipment near any heat source, in direct sunlight, in high ambient areas, or without proper clearance for ventilation. Placing equipment in these locations will result in reduced capacities, high system pressures and may cause equipment failure.

**Note:** Each Kold-Draft ice machine has successfully completed a quality assurance test and has been factory inspected before shipping. When receiving the unit please inspect it for physical damage. If damage is found:

1. Have carrier note the damage on the bill of lading.
2. File a damage claim report with the carrier immediately.
3. Call Kold-Draft with your claim number to arrange replacement or repair.

### **What's in the Box**

- Kold-Draft Ice Machine
- Warranty card attached to the front of the machine
- Two ice deflectors (four ice deflectors with a GB106x machine)
- Drain Pan hose with clamp (Two hoses and two clamps with a GB106x machine)
- Adhesive-backed foam weather-strip tape
- Information packet
  - Installation And Operation Manual
  - 4x 1/4-20 stainless steel bolts
  - 4x 1/4" stainless steel washers
  - 2x 8-32 pan head stainless steel Philips head screws

### **Required Tools**

- #2 Philips Head Screwdriver
- 7/16" Socket and Wrench
- Channel Lock Pliers

## **Pre-Install Checklist**

- Ambient air temperatures at the install location are between 45°F (7°C) and 90°F (32°C), the machine must be installed indoors.
- The machine will have the minimum opening sizes listed below. Heights listed are strictly the ice machine and do not include the height of the bin. Depths listed are adjusted to accommodate plumbing and electrical hookups.

<b>Model</b>	<b>Width</b>		<b>Depth</b>		<b>Height</b>	
	<b>(in)</b>	<b>(cm)</b>	<b>(in)</b>	<b>(cm)</b>	<b>(in)</b>	<b>(cm)</b>
GT36xA & GT36xL	38	97	29	74	17	43
GT56xA ,L,R	38	97	29	74	32	81
GB56xA	54	137	38	97	17	43
GB56xL,R	54	137	29	74	17	43
GB106xA	54	137	38	97	40	102
GB106xL,R	54	137	29	74	40	102

- Each ice maker and each ice bin must enter the drain stack through separate connections. Models equipped with a liquid condenser that does not re circulate coolant must have a drain for each condenser that enters the drain stack through separate connections
- The drain hose or pipe will remain a constant diameter from the machine to the drain
  - The building drain must be able to accommodate all the drain water from the ice machine operation.
- Individual drains will not be directly connected to a common manifold, drain or standpipe. If individual drains are to be discharged into a common manifold, drain or standpipe, a minimum 38mm (1.5") air gap must be provided at each connection. This is to prevent any backflow of drain water into the ice maker or ice bin.
- Drain lines will be installed with a minimum drop of 1" per 3' run (2.5cm per meter run).
- The temperatures of the water supply fall between 45°F (7°C) and 90°F(32°C)
- The water supply must be potable, not laden with sediment, and have free chlorine levels no greater than 0.2ppm.
- A minimum 5 psig (0.034 MPA) dynamic water supply pressure is required for proper operation of the ice maker water valve. Please note that on liquid cooled ice machines, where the same water supply is used for both condenser cooling and the potable water supply, the demand for condenser coolant may cause the supply pressure to drop. This is most notable at the time of peak load, at the beginning of the freeze cycle. The maximum water supply pressure is 100 psig (0.6 MPA).
- All water lines have been purged before connection.
- All KOLD-DRAFT models are intended to be installed with a permanent connection to the field electrical supply. Drop cord connections are not to be used with this equipment. Always be sure the power supply is the same as the ice machine's electrical specification, which is listed on the serial number tag on the front of the top frame cross member
- Each ice maker must be connected to the grid through its own dedicated fuse or HACR type circuit breaker.
- Each ice maker must be connected to a separate protected circuit with no other loads.
- Fused disconnects, installed adjacent to each ice maker, are recommended and may be required by local codes. These components must be supplied by the installer.

- Electrical service must fall within the voltage tolerances listed below:

Nominal (V)	No-Load Maximum	Full-Load Minimum
115 (1 Series)	126	104
208-230 (4 and 5 Series)	250	198
230 (7 Series)	250	210
220/380 (8 Series)	420/3 phase	210/1 phase

- Breaker or fuse service must be no greater than the maximum rating as specified on the rating label attached to the back of the machine.
- The minimum circuit ampacity listed on the back of the machine does not indicate a typical running current value. Use the minimum ampacity value for sizing branch circuit conductors up to 26 feet (8 meters) in length. For a conductor length over this length, increase the wire gauge as required by code.

**DANGER:** Failure to comply with these regulations may cause serious injury or death and cause damage to the machine and its surroundings.

**Warning:** **Water Treatment:** There are no specific requirements for water treatment provided that the ice making supply water is potable and not laden with sediment. **The use of additional water treatment may facilitate or reduce the frequency of the need for cleaning.** Please consult your local water conditioning supplier for specific recommendations.

Note:

- Ambient temperatures higher than the maximum specification will result in reduced capacities and high system pressures in air-cooled models. Temperatures lower than the minimum will cause the machine to malfunction due to an inability to eject the ice from the evaporator. Ambient temperatures less than 60°F (15°C) may cause the bin thermostat to malfunction.
- Clearance must be provided for ventilation and access for service. Ventilation is especially important for models with air-cooled condensers. Failure to provide adequate clearance may result in reduced capacities and high system pressures.
- Ice machine drains and bin drains may be insulated to prevent condensation.
- The use of water treatment may increase the intervals between cleaning operations and the overall machine life.
- If a water pressure regulator is used, the recommended setting is 30 to 50 psig (0.2 MPA to 0.3 MPA) dynamic.
- Do not connect the ice machine to a hot water supply line. Insulate the water line from sources of heat for greater operating efficiency. Supply water temperatures higher than the recommended maximum will cause reduced capacities.
- Normal protector size is based on rated voltage and operation at lower than extreme temperature limits. Branch circuit conductors may be sized to allow increasing the protector value up to the specified maximum. This may avoid nuisance protector opening under harsh operating conditions.

### **Additional Pre-install Information for Cooling Tower Applications (L models)**

The ice machine does not need to be modified for use with a cooling tower provided the cooling tower is properly designed for the application. Information regarding the amount of heat rejection, as well as the pressure drop through the condenser and liquid valves is required to properly select or design a cooling tower application for an ice machine.

Coolant entering the condenser must not exceed 90°F (32.2°C).

Coolant exiting the condenser must not exceed 110°F (43.3°C).

Allow for a pressure drop of 7 psi (48 KPA) between the liquid coolant inlet and outlet of the condenser.

The condenser liquid control valve will regulate the flow of coolant through the condenser, thereby controlling the high side pressure in the ice machine.

## ASSEMBLY

### Unpacking

Unpacking a KOLD-DRAFT machine can be done by prying off the boards that are holding the cardboard box to the shipping pallet. The box can then be lifted vertically to expose the machine. Tools to complete this job would include a claw hammer or some other form of pry-bar.

### Assembly Procedure

1. Remove the ice machine front-cover panel, top-cover panel and side-cover panels from the ice machine frame.
2. Remove all shipping materials from the ice machine. Cut off the water plate shipping strap.
3. For proper operation the ice machine and ice bin must be on a level surface. If the surface the ice bin will be installed on is not level, use shims or the adjusters on the ice bin legs to bring the machine to level. If shims were used, seal the bin to the floor using a sealant with NSF certification. If there are gaps larger than 1/8" (3mm) install a cove molding around the bottom of the bin to reduce the gap and seal the cove molding to the floor with the approved sealant.
4. Confirm that the following holes are installed in the bin top: a hole corresponding to the ice drop zone, drain pan outlet, bin level probe and the threaded mounting holes for the supplied bolts at the four corners of the machine. The hole for the drain pan outlet should be 2" (5cm) in diameter to allow sufficient access for the clamp. Drain hoses for drain pan outlets in GT36x, GT56xA, GB56x and the lower halves of GB106x models get directed through the back of the ice bin. Drain hoses for drain pan outlets in GT56xL and the upper halves of GB106x models get directed through pre-cut holes in the back of the ice machine frames. Drain pans should never be allowed to drain directly into the ice bin. After installation, seal around the drain tube where it leaves the machine.

Note: All KOLD-DRAFT bins will have a provision for the drain pan outlet tube to exit the rear of the bin. Ice machines that will be used on bins not manufactured by KOLD-DRAFT will require a drain riser adapter made by KOLD-DRAFT to allow sufficient clearance for the drain pan outlet tube to exit the back of the assembly.

5. Install gasket on top of bin if not already installed. Gasket material must be positioned so that it extends to the outside edge of the perimeter of the ice maker chassis when the ice-maker is in place. To apply the gasket, peel away the white backing strip and press firmly in place.
6. Carefully lift the ice machine and position it on the ice storage bin. Securely attach the ice machine to the ice storage bin with the supplied washers and bolts or other non-corroding hardware if not installed on a KOLD-DRAFT bin. If the ice machine is installed on an installed with an accessory such as a crusher, follow the installation instructions with the other equipment.

**DANGER: It is highly recommended that 2 or more people perform this job, if the machine falls it could cause serious injury or death.**

7. Make all plumbing and electrical connections to the ice machine and ice storage bin in accordance with local regulations.
8. Remove the strap securing the bin level probe and install through the bottom of the ice machine. Ice machines on top of other ice machines or ice crushers should have the bin probe stuck through the bottom of the machine directly above the bin. The hole for the bin probe will be in the same location on all variations of these machines, just to the right of the ice-making compartment or the ice chute in GT56x applications.

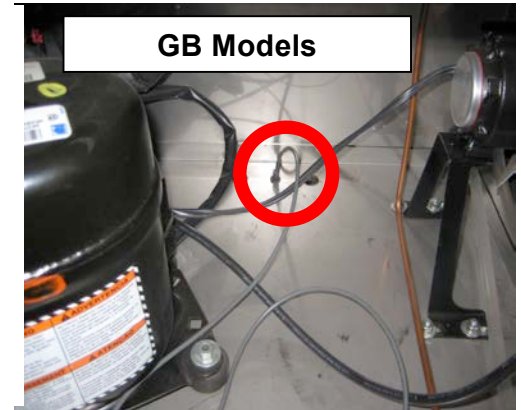
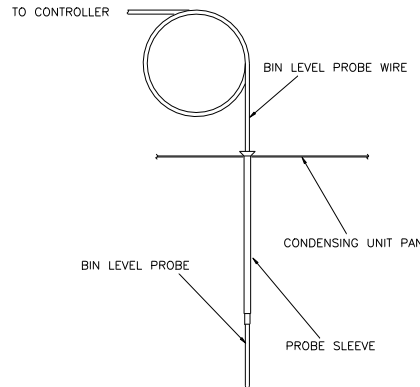
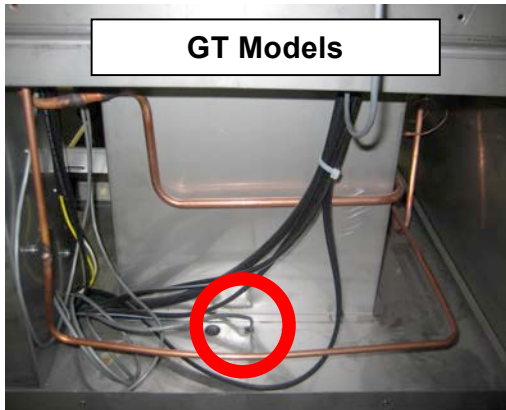

9. Install the ice deflectors.

**Front Deflectors:**

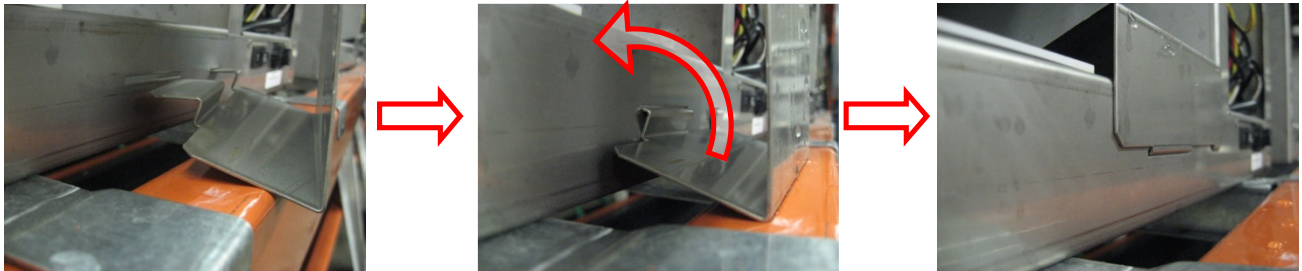

**Rear Deflectors:**



## **INITIAL START PROCEDURE**

1. Be sure that the on-off switch is in the “off” position and the ice-clean switch is in the “clean” position.
2. Turn on the power and water supply and check all supply lines for leaks.
3. Make sure all pump and water tank hoses are connected, then pour 1/2 quart (1/2 liter) of clean potable water into the circulation system to lubricate and prime the pump(s).

Note: this can be done by either pouring the water directly onto the evaporator, the evaporator is equipped with drain holes for this purpose and to allow melted frost to drain into the water tank. In tight spaces a funnel and hose can be used to pour water onto the evaporator. Alternatively the water can slowly be poured into the clear control stream box on the front of the water plate or between the evaporator and the top left wall of the water plate.

4. Move the on-off switch to the “on” position and observe the water flowing from the distributor tube filling the water tank. Also, observe that the water pump is circulating water through the system. A momentary sucking, cavitation sound is normal at the beginning of the process when the water level is low. The water fill is complete when the water level in the probe tube reaches the high-level probe. Observe that the water valve is de-energized by ensuring water has stopped flowing through the distributor tube. Check that there are no water leaks from the hoses or water tank into the drain pan.

Note: For GB106x models, observe that the water fill difference between the upper and lower water tanks measured from the top of the control stream box is less than 1/8 inch (3 mm) for “C” models and 1/4 inch (6 mm) for “HK” models.

5. Pull down on the right side of the water plate, stretching the springs until the water plate switch is disengaged, observe that the pump stops and the actuator motor rotates the cam arms counter-clockwise. Observe that the cam arms continue to turn, opening the water plate fully, dumping the water in the tank. After a moment, the cam arm rotation will reverse and close the water plate. The cam arm rotation will stop when the water plate is fully closed and the water fill process will repeat.
6. Move the ice-clean switch to the “ice” position, the water plate will cycle down and up one more time dumping the water. When this completes the machine will begin to make ice, observe that the compressor and the condenser fan motor, if so equipped, begin to run. If possible with liquid cooled models ensure there is water flow during the ice making cycle.
7. Test the bin level control operation by holding ice against it. Adjust the controller, if required, to shut off the ice machine within 30 seconds of contact between the ice and probe.
8. Make sure that the drain pan, ice deflectors and stacking chute (GB106x models and stacked ice machines only) are properly installed. Replace and secure all the cabinet panels. The front panel gets secured to the machine with the provided stainless steel sheet metal screws.
9. Discard all the ice from the start-up cycles, then clean and sanitize the ice storage bin according to the instructions provided with the bin.
10. Complete and mail the registration certificate to the factory. Leave all instructions with the owner/user.

## **ICE MACHINE CLEANING PROCEDURE**

**It is recommended to perform this cleaning procedure at a minimum twice per year.**

Note: Use a clean plastic bottle fitted with a stopper or cap that has a pouring tube and a vent to facilitate mixing and pouring of the specified solutions.

1. Mix 3 oz. (500023) KD Nickel-Safe Ice Machine Cleaner per gallon of warm water.
2. If the ice machine is operating, wait until the ice falls out of the evaporator, then move the Ice-Clean Switch to the "Clean" position.
3. Empty the storage bin and turn off any other ice machines on the same bin.
4. After the water fill is complete, turn off the ice machine. While pinching the water level control tube, remove it from the probe cap. Hold the water level control tube high enough so that the water does not overflow, release the control tube and pour about half the cleaning solution into the top of the probe tube. Pinch the control tube again and reassemble the probe tube to the cap. Pour the remaining cleaning solution into the control stream box.
5. Turn on the ice machine and allow the solution to circulate for 15 minutes then pull down on the right side of the water plate. This will cause it to open and dump the cleaning solution and then refill with water. Repeat the dump process three times to be sure all the cleaning solution is rinsed out of the machine.
6. Mix a sanitizing solution containing 0.5 ounce (15 ML) 5-1/4% sodium hypochlorite (household bleach or equivalent) and 1 quart (3.8 Liter) clean water.
7. Using the same process as in step #4, pour half of the sanitizing solution into water level probe tube and the other half into the control stream box.
8. Allow the solution to circulate for 15 minutes. Pull down on the right side of the water plate, to cause it to open and dump the sanitizing solution and then refill with water. Repeat this process two times to be sure all the cleaning solution is rinsed out of the machine. If necessary, adjust the water level probes to the proper levels.
9. While the cleaning and sanitizing solutions are circulating, clean and rinse all accessible parts and surfaces of the ice machine with clean towels and . Mix a cleaning solution containing 8 tablespoons (1/2 cup) (96g) baking soda and 1 Gal. (3.8 Liter) of warm water and a sanitizing solution containing 1 teaspoon (5 ML) 5-1/4% sodium hypochlorite and two quarts (1.9 Liter) of clean water.
10. After cleaning has been completed, move the Ice-Clean Switch to the "Ice" position. Check the operation of the machine, particularly the water level and subsequent ice cube formation. Adjust the water level probes if needed.

# SPECIFICATIONS

## Machine Capacities

Model Number	Capacity and Energy Input Ratings				Water Use, gal/100# (l/kg)		Cubes per cycle	
	Lb (Kg) per 24hr		kWh/100# (kJ/kg)	kWh/100# (kJ/kg)	Potable	Condenser		
	90/70 Ambient/Water							70/50 Ambient/Water
GT361AC	216 (98)		7.95 (631)	270 (122.47)	5.96 (473)	22 (1.84)	n/a	63
GT361AHK	255 (116)		7.31 (581)	332 (150.59)	5.12 (406)	23.6 (1.97)	n/a	126
GT361LC	262 (119)		5.56 (441)	309 (140.16)	4.56 (362)	22.2 (1.85)	165.3 (13.79)	63
GT361LHK	316 (143)		5.18 (411)	373 (169.19)	4.25 (337)	22.9 (1.91)	180.7 (15.08)	126
GT364AC	215 (97)		7.57 (601)	269 (122.01)	5.68 (450)	22.1 (1.8)	n/a	63
GT364AHK	255 (116)		6.91 (548)	332 (150.59)	4.84 (384)	23.6 (1.97)	n/a	126
GT364LC	255 (115)		5.76 (457)	301 (136.53)	4.72 (374)	22 (1.8)	163.4 (13.63)	63
GT364LHK	303 (137)		5.34 (424)	358 (162.38)	4.38 (347)	23.2 (1.94)	188.5 (15.73)	126
GT561AC	369 (167.22)		6.63 (526)	458 (207.74)	5.04 (400)	16.6 (1.39)	n/a	108
GT561AHK	453 (205.44)		6.19 (491)	575 (260.81)	4.52 (358)	20.4 (1.7)	n/a	216
GT561LC	447 (202.56)		5.15 (408)	510 (231.33)	4.43 (351)	13.2 (1.1)	137.4 (11.47)	108
GT561LHK	500 (226.89)		4.85 (384)	580 (263.08)	4.07 (323)	17.1 (1.43)	175.9 (14.68)	216
GT564AC	380 (172.19)		6.88 (545)	471 (213.64)	5.23 (415)	16.7 (1.39)	n/a	108
GT564AHK	433 (196.49)		5.99 (475)	550 (249.47)	4.37 (346)	18.4 (1.54)	n/a	216
GT564LC	429 (194.43)		5.14 (407)	489 (221.80)	4.42 (350)	16.9 (1.41)	175.6 (14.65)	108
GT564LHK	494 (224.26)		4.73 (375)	573 (259.90)	3.97 (315)	15.9 (1.33)	144.2 (12.03)	216
GB561AC	360 (163)		7.1 (563)	446 (202.30)	5.40 (428)	25 (2.1)	n/a	108
GB561AHK	428 (194)		6.6 (524)	544 (246.75)	4.82 (382)	25 (2.1)	n/a	216
GB561LC	420 (190)		5.5 (437)	479 (217.27)	4.73 (375)	25 (2.1)	142 (11.9)	108
GB561LHK	500 (227)		5.0 (397)	580 (263.08)	4.20 (333)	25 (2.1)	148 (12.4)	216
GB564AC	357 (162)		7.2 (571)	443 (200.94)	5.47 (434)	25 (2.1)	n/a	108
GB564AHK	424 (192)		6.5 (516)	538 (244.03)	4.75 (377)	25 (2.1)	n/a	216
GB564LC	460 (209)		5.2 (413)	524 (237.68)	4.47 (354)	25 (2.1)	150 (12.5)	108
GB564LHK	460 (209)		5.2 (413)	534 (242.21)	4.37 (346)	25 (2.1)	165 (13.8)	216
GB1064AC	725 (329)		6.1 (484)	906 (411)	4.58 (363)	23 (1.9)	n/a	216
GB1064AHK	823 (373)		5.6 (445)	1045 (474)	4.09 (324)	26.5 (2.2)	n/a	432
GB1064LC	835 (379)		4.46 (354)	952 (432)	3.84 (304)	16.1 (1.34)	141.8 (11.83)	216
GB1064LHK	900 (408)		4.6 (365)	1044 (473)	3.86 (306)	24 (2.0)	163 (13.6)	432
GB1064RC & RC214APV	760 (345)		5.9 (468)	950 (431)	4.43 (351)	25 (2.1)	n/a	216
GB1064RHK & RC214APV	850 (386)		5.6 (444)	1080 (490)	4.09 (324)	25 (2.1)	n/a	432

## Electrical Use and Machine Dimensions/Weight

Model Number	Amps	Amps	CA Power Tier	Dimensions - inches (cm)			Ship Weight
	Min Circuit	Max Fuse/Breaker		W	D	H	Ship Weight #(kg)
GT361AC	12	15	1	30.1 (76.5)	25.7 (65.3)	16.9 (42.9)	180 (82)
GT361AHK	12	15	1	30.1 (76.5)	25.7 (65.3)	16.9 (42.9)	180 (82)
GT361LC	11.1	15	2	30.1 (76.5)	25.7 (65.3)	16.9 (42.9)	174 (79)
GT361LHK	11.1	15	2	30.1 (76.5)	25.7 (65.3)	16.9 (42.9)	174 (79)
GT364AC	6.5	15	2	30.1 (76.5)	25.7 (65.3)	16.9 (42.9)	180 (82)
GT364AHK	6.5	15	2	30.1 (76.5)	25.7 (65.3)	16.9 (42.9)	180 (82)
GT364LC	6	15	1	30.1 (76.5)	25.7 (65.3)	16.9 (42.9)	174 (79)
GT364LHK	6	15	2	30.1 (76.5)	25.7 (65.3)	16.9 (42.9)	174 (79)
GT561AC	18.6	30	1	30.1 (76.5)	25.7 (65.3)	30.7 (78)	228 (103)
GT561AHK	18.6	30	1	30.1 (76.5)	25.7 (65.3)	30.7 (78)	228 (103)
GT561LC	17.7	30	1	30.1 (76.5)	25.7 (65.3)	30.7 (78)	218 (99)
GT561LHK	17.7	30	1	30.1 (76.5)	25.7 (65.3)	30.7 (78)	218 (99)
GT564AC	9.5	15	1	30.1 (76.5)	25.7 (65.3)	30.7 (78)	228 (103)
GT564AHK	9.5	15	1	30.1 (76.5)	25.7 (65.3)	30.7 (78)	228 (103)
GT564LC	9.1	15	1	30.1 (76.5)	25.7 (65.3)	30.7 (78)	218 (99)
GT564LHK	9.1	15	1	30.1 (76.5)	25.7 (65.3)	30.7 (78)	218 (99)
GB561AC	18.6	30	1	42.3 (107.4)	31.1 (79)	17 (43.2)	207 (94)
GB561AHK	18.6	30	1	42.3 (107.4)	31.1 (79)	17 (43.2)	207 (94)
GB561LC	17.7	30	1	42.3 (107.4)	25.63 (65.1)	17 (43.2)	185 (84)
GB561LHK	17.7	30	1	42.3 (107.4)	25.63 (65.1)	17 (43.2)	185 (84)
GB564AC	9.5	15	1	42.3 (107.4)	31.1 (79)	17 (43.2)	207 (94)
GB564AHK	9.5	15	1	42.3 (107.4)	31.1 (79)	17 (43.2)	207 (94)
GB564LC	9.1	15	1	42.3 (107.4)	25.63 (65.1)	17 (43.2)	185 (84)
GB564LHK	9.1	15	1	42.3 (107.4)	25.63 (65.1)	17 (43.2)	185 (84)
GB1064AC	16.3	25	1	42.3 (107.4)	31.1 (79)	33.7 (85.6)	348 (158)
GB1064AHK	16.3	25	1	42.3 (107.4)	25.7 (65.3)	33.7 (85.6)	312 (142)
GB1064LC	15.4	25	1	42.3 (107.4)	25.7 (65.3)	33.7 (85.6)	312 (142)
GB1064LHK	15.4	25	1	42.3 (107.4)	25.7 (65.3)	33.7 (85.6)	312 (142)
GB1064RC & RC214APV	18.1	30	1	42.3 (107.4)	25.7 (65.3)	33.7 (85.6)	335 (152)
GB1064RHK & RC214APV	18.1	30	1	42.3 (107.4)	25.7 (65.3)	33.7 (85.6)	335 (152)
RC214APV				40.75 (103.5)	22.75 (57.8)	30.2 (76.6)	160 (73)

## Water Fill Levels, Cycle Times and Harvest Weights

	Model Group and Cube Type			
	GB56x		GB106x	
	C	HK	C	HK
Water Fill Level inches (mm) *	2.75 (70)	2.75 (70)	2.75 (70)	2.75 (70)
Approximate Cycle Time (Minutes)	31	24	31	24
Approximate Harvest Weight-lbs. (kg)	7.70 (3.49)	7.10 (3.22)	15.40 (6.98)	14.20 (6.44)

Note: Rough measurement from top edge of water tank to water level in control tube after water fill is complete. Additional fine adjustments may be required.

## Cube Information

Cube Type	Cube Dimensions in. (mm)	Cube Weight oz. (g)	Cubes per Cycle	
			GB56x	GB106x
C (Full Cube)	1.25 x 1.25 x 1.25 (31 x 31 x 31)	1.15 (32.6)	108	216
HK (Half Cube)	1.25 x 1.25 x .62 (31 x 31 x 15)	.53 (15.0)	216	432

## Typical Refrigerant Operating Pressures

Measurement Point	Approximate Low Side (Suction Pressure)	High Side (Discharge Pressure) (R-404a)	
		Approximate Air Cooled	Approximate Liquid Cooled
Beginning of Freeze Cycle	50 PSI (345 KPA)	See Note 1	1650 KPA (See Note 3)
Just Before Defrost Cycle Begins	12 to 20 PSI (80 to 140 KPA)	See Note 2	1650 KPA (See Note 3)
During Defrost Cycle	70 to 150 PSI (480 to 1030 KPA)	150 PSI (1030 KPA)	150 PSI (1030 KPA)
Note 1- High side pressure in air cooled models, at the beginning of the freeze cycle, is likely to be higher than 250 PSI (1720 KPA)			
Note 2- High side pressure in air-cooled models, at the end of the freeze cycle, is likely to be lower than 250 PSI (1720 KPA).			
Note 3- 240 PSI (1650 KPA) is equivalent to 101°F (38°C) condensing temperature			

## COMPONENTS

### Mechanical Components

**Refrigerant Compressor:** Provided to pump refrigerant through the refrigeration system. See the serial number plate for refrigerant specification and electrical characteristics.

**Condenser:** All air-cooled and liquid-cooled models are provided with a self-contained refrigerant condenser to remove heat from the refrigeration system. These condensers are designated in the model number as (“A”) air-cooled and (“L”) liquid-cooled. Remote air-cooled condensers are also available for some models. These are designated as (“R”) in the model number. (See the remote air-cooled section of the manual for information on these models.)

**Condenser Fan and Motor:** Provided with all air-cooled (“A”) models to draw air through the condenser.

**Liquid Regulator Valve:** Provided with all liquid-cooled (“L”) models to regulate the flow of coolant through the condenser and maintain a specified refrigerant discharge pressure.

**Heat Exchanger:** Provided to sub-cool the refrigerant, ensuring that the refrigerant is liquid at the inlet of the expansion valve.

**Filter Drier:** Provided as insurance that all moisture and impurities are removed from the refrigeration system.

**Thermostatic Expansion Valve:** Maintains the proper flow of refrigerant, through the system, as the load changes during the ice making cycle.

**Evaporator:** A plated copper evaporator is found in all models. The evaporator provides the five freezing surfaces for ice cube formation.

**Defrost Valve:** Directs compressor discharge gas to the evaporator, warming it to release the ice cubes during the harvest cycle.

**Water Tank:** Provided as a sump to hold the water required to make one batch of ice cubes.

**Water Solenoid Valve:** Opens to allow potable water to enter the ice machine and closes when the water tank is filled to the correct level.

Note: There is a strainer in the water valve inlet, which protects the water valve from particles in the water supply. If the need for cleaning this strainer is frequent, an external water filter should be provided.

**Water Plate:** Functions as a water manifold with a flat surface and to regulate the web thickness between the cubes. This surface is positioned close to the evaporator and acts to form the sixth side of the ice cubes. The water plate surface has one spray hole for each cell in the evaporator, to provide water to the freezing surfaces. The water plate surface also has two drain holes under each cell, to allow unfrozen water to return to the water tank to be re-circulated. The water plate swings down during the harvest cycle to allow the ice cubes to fall out of the evaporator.

Note: If at any time during the Fill, Freeze, or Circulate cycle the water plate is manually opened the controller will switch to the step 3 of the ice making sequence on page 28.

**Water Pump:** Continuously circulates the water from the water tank, through the water plate during the ice making cycle. The water pump also operates during the wash cycle to circulate cleaning and sanitizing solution.

**Actuator Motor:** Rotates the cam arms counter-clockwise, at the beginning of the ice harvest cycle, to lower the water plate, so the ice can fall out of the evaporator. It then rotates clockwise, at the end of the harvest cycle, to close the water plate for the next ice making cycle.

**Actuator Motor Capacitor:** Installed between the two actuator motor windings, the function of this capacitor is to determine the direction of the rotation of the actuator motor.

**Cam Arms:** These are attached to the actuator motor output shaft and function initially to separate the water plate from the evaporator and then to support the water plate as it opens fully.

**Water Plate Springs:** Function as the connection between the cam arms and the water plate. They also act as a safety mechanism, stretching if any ice remains on the water plate surface as it is closing against the evaporator.

**Drain Pan:** Provided to catch the dreg water at the end of the ice making / cleaning and sanitizing cycles and directs it to the drain.

**Ice Deflectors-Front and Rear:** Provided to direct the falling ice to the storage bin.

**Controller:** Controls the ice machine utilizing multiple sensors, provides power directly to many of the ice machine components. Through solid-state relays, outputs and indirectly to the compressor and condenser fan motor, if so equipped, by operation of the Contactor. The controller also provides status indication of the ice machine and components as well as diagnostics for service personnel.

**On-Off Switch:** The “On” position provides power to the controller to operate the ice machine. The “Off” position interrupts power to the controller to shut down the ice machine.

**Caution:** Switching the machine “off” does not de-energize circuits, disconnect power before servicing.

**Ice-Clean Switch:** The “Ice” position signals the controller to provide full operation of the ice machine. The “Clean” position signals the controller to exclude operation of the contactor and thereby the compressor and condenser fan motor if so equipped. This position is useful for cleaning the ice machine and for test procedures where operation of the compressor is not required or desired.

**Ice Level Probe:** Senses when the ice bin is full- Contact between this probe and the ice in the storage bin will signal the controller to shut off the ice machine. When ice is removed from the probe, the ice machine will restart.

**Adjustment:** While holding ice against the probe tube, turn the adjustment knob on the controller to shut off the ice machine within one minute. A warmer (CCW Bottom blue knob) adjustment will shut off the ice machine sooner. A colder (CW) adjustment will delay shut off.

**Evaporator Temperature Probe:** Senses the temperature of the evaporator. During the defrost cycle, the evaporator must warm sufficiently to release the ice. This probe signals the controller to terminate the defrost cycle, after the ice has fallen out of the evaporator, and start the next ice making cycle.

Note: A secondary function of this probe is to signal the controller to shut off the ice machine if the evaporator should overheat.

Adjustment: Turn the adjustment knob on the controller warmer (CCW Top blue Knob), only if the defrost time is insufficient to drop all the ice from the evaporator, before the water plate begins to close. The defrost time should be increased no more than is required to ensure all the ice has fallen from the evaporator.

**Control Stream:** This is a small clear box, divided into two sections and located on the front face of the water plate. It is a “safety valve” that ensures evacuation of the water reservoir so that harvest cycles will begin without undue delay. Water flowing into the left section of the box is returned to the water tank and re-circulated through the system. Water flowing into the right section of the box is drained out of the system. The velocity of the stream flowing in the box, during the ice making cycle, is an indicator of the water pressure inside the water plate. This pressure will increase as the ice cubes fill out in the evaporator, covering the drain holes provided for each cell. This pressure increase will cause the stream, normally flowing into the left section of the box, to flow over the partition and into the right section, draining the system of excess water.

Adjustment: Turn the Philips head screw located behind the expansion valve such that the stream of water falls to the left of the control stream box partition, during the early portion of the ice making cycle, before the cubes are full.

**Water Level Probe Assembly:** This assembly consists of three stainless steel probes or a float type which are positioned in a clear water level tube. The water level tube is mounted in front of the water tank and is connected to it by a hose. The water level in the tank is visible in the tube. The water level probes or float are positioned in the water level tube. The longest is a reference probe and the tip of this probe is at the bottom of the tube. The next longest probe is the “LOW PROBE.” When the water level is low enough to separate from the tip of this probe, the controller is signaled to start the harvest cycle. The shortest probe is the “HIGH PROBE.” When the water level touches the tip of this probe during the water fill, the controller will de-energize the water inlet valve. The water level probe float type has a HIGH float and LOW float. As of 1/1/17 we will be adding a dual float, left side float is for harvest, right side is for water level. Adjustments stay the same.

Adjustment: The reference probe should be adjusted all the way down. The “Low Probe” should be adjusted so the tip is approximately .60” (15 mm) from the bottom of the probe tube. The “High Probe” determines how much water is taken into the system at the beginning of a cycle. It is adjusted as required by the size of the cube (“C” or “HK”) and the desired fullness (dimple size) of each cube. Typically all cubes should have a small dimple at the end of the freeze cycle. Lack of a dimple in the cubes is an indicator that the water tank level is too high at the start of the cycle. The water level probe float type has a HIGH float determines how much water is taken into the system at the beginning of a cycle and LOW float when it is low enough to tip the controller is signaled to start the harvest cycle.

Note: Making cubes without a 1/8 dimple will reduce ice machine capacity and may damage the water plate surface in extreme cases. If the control stream is draining water for more than 15 seconds, at the end of the ice making cycle, the water level in the tank is

too high. Lower the high probe or raise the low probe slightly, until proper operation is evident.



## WATER LEVEL ASSEMBLY (FLOAT TYPE) INSTALLATION INSTRUCTIONS

DOCUMENT #307 1054 01

### CAUTION! RISK OF PERSONAL INJURY, PROPERTY DAMAGE, EQUIPMENT FAILURE OR FIRE

Refer all maintenance to qualified personnel. Disconnect power before servicing equipment.

Read and understand all instructions before proceeding.

#### REMOVE OLD WATER LEVEL PROBES, WIRE HARNESSSES AND CONNECTORS

Remove the old water level probe assembly, wire harnesses and connectors from the control box all the way to the water level tube on the water plate. Start in the top right corner of the control box. On the PC board, there is a small black connector with black, white and red wires. Un-clip it and remove it thru the hole in the top/back of the control box. Remove all connected wire harnesses & connectors all the way to the water level tube on the water tank. Note which way the wiring is routed, for installation of the new water level probe assembly. You may cut out the wiring & connectors from the old water level probe assembly as needed. All new wire harnesses and connectors will be supplied with the new water level probe assembly.

#### CONNECT NEW WATER LEVEL PROBE, WIRE HARNESSSES AND CONNECTORS

1. In the replacement kit, find the harness with the small black connector on one end. Feed the black connector thru the hole in the control box and plug it into the PC board. The terminals on the other end of the harness will be connected in step 3 below.
2. Place the new probe with the correct float setup (see FLOAT SETUP below) into the water tube and hang it back onto the top edge of the water tank. Run the other end of the probe wire harness thru the machine to near the back of the control box.
3. Connect the terminals on the ends of the black, white & red wires to the terminals on the ends of the black, white & red wires on the harness you installed into the control box in step 1 above, being sure wire colors correspond for each connection.

#### FLOAT SETUP

In order for the probe switches to correctly work for **K CUBE** machines the top float must be flipped over so the magnetic strip is on top. The round blue disk above the top float must also be moved down to the empty groove below it. Both the K and C/HK setups are shown in the picture below. The black dots indicate where the magnetic strip is. If you are unsure where the magnetic strip is located, hold the float up to a light source and the magnetic ring will be more easily identified.

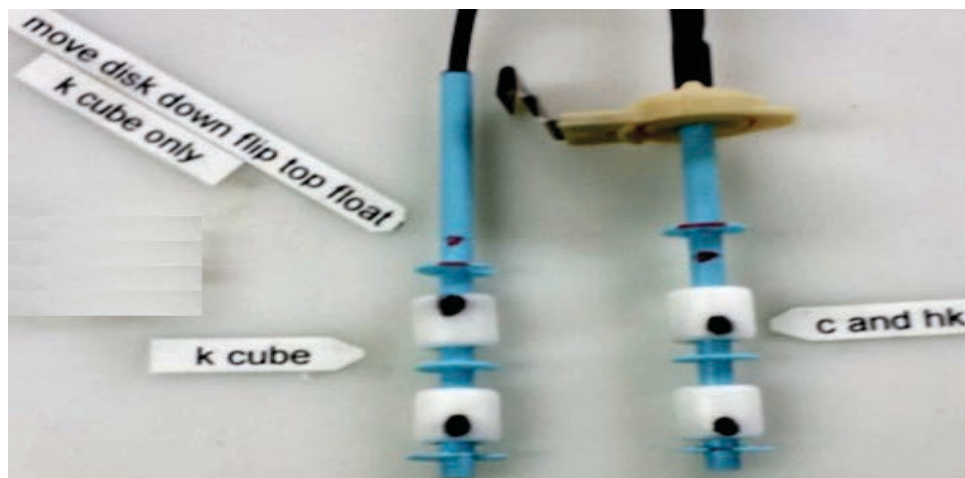

#### FLOAT ADJUSTMENTS

In order for the machines to make a solid cube some adjustments may be needed. If the ice being harvested is too light or does not have the right dimple size to make it solid, the entire probe will need to be raised slightly. This can be done by grabbing the probe at the top and pulling slightly. If the ice is too solid and there is no dimple in the ice cube then the probe needs to be lowered. Grabbing the probe at the top and pushing it in will lower it. Raise or lower the probe for right **ICE CUBE QUALITY** Proper adjustment of the control stream and water level probes will produce ice cubes containing a 1/8" to 3/16" dimple.

**Plate Up Switch:** This switch is actuated by the water plate and informs the controller about the position of the plate—fully up or not fully up. If this switch/magnetic is not actuated when the water plate closes, because ice is remaining on the water plate surface, the actuator motor will reverse and reopen the water plate. This will continue until the surface is clear.

Adjustment: The switch/magnetic should be actuated when the front cam arm is between the 10 o'clock and 11 o'clock positions. The switch/magnetic is closed when the "plate up" LED is lit. Adjust the actuation point by adjusting the height of the white actuation screw on the water plate.

Note: Do not bend the switch lever to make this adjustment.

**Arms Up Switch:** This switch acts to limit the clockwise rotation of the actuator motor. It informs the controller when the cam arms are in the "12 o'clock" position (water plate up), so the actuator motor can be de-energized.

Adjustment: The switch operator, which is attached to the output shaft of the actuator motor, can be rotated on the shaft and fixed in place with a set screw. When adjusted properly, the cam arm will stop in the "12 o'clock" position. The motor stops when the flat spot on the switch operator allows the switch lever to drop down.

Note: The front water plate spring must be on the left side of the cam hub when the water plate is fully closed (cam arm in the 12 o'clock position).

**Arms down Switch:** This switch acts to limit the counter-clockwise rotation of the actuator motor. It informs the controller when the cam arms are in the "7 o'clock" position (water plate down), so the actuator motor can be de-energized.

Adjustment: The switch operator, which is attached to the output shaft of the actuator motor, can be rotated on the shaft and fixed in place with a set screw. When adjusted properly, the cam arm will stop in the "7 o'clock" position. The motor stops when the flat spot on the switch operator allows the switch lever to drop down. Do not allow under-travel or over-travel so that the water plate is not in the most fully-open position (critical with HK models)

**Contactors:** Provided with all models to carry the compressor load. On self-contained and remote air-cooled models, the condenser fan motor is also connected to the contactor. The contactor coil is rated for line voltage and the contacts are rated for definite purpose applications (FLA and LRA).

**High Pressure Cutoff:** A manual reset pressure switch is provided, which will open the circuit to the contactor coil if the discharge pressure should reach 435 psig (2.38 MPA gauge). As of 04/16 new AUTOMATIC no need to reset it.

### **GB106x Series Unique Components**

**Stacking Chute:** Provided to direct the ice, from the upper ice making section, down through the lower ice making section of these machines.

**Ice Deflectors-Upper Front and Rear:** Provided to direct the falling ice, from the upper ice making section, to the stacking chute.

## Controller

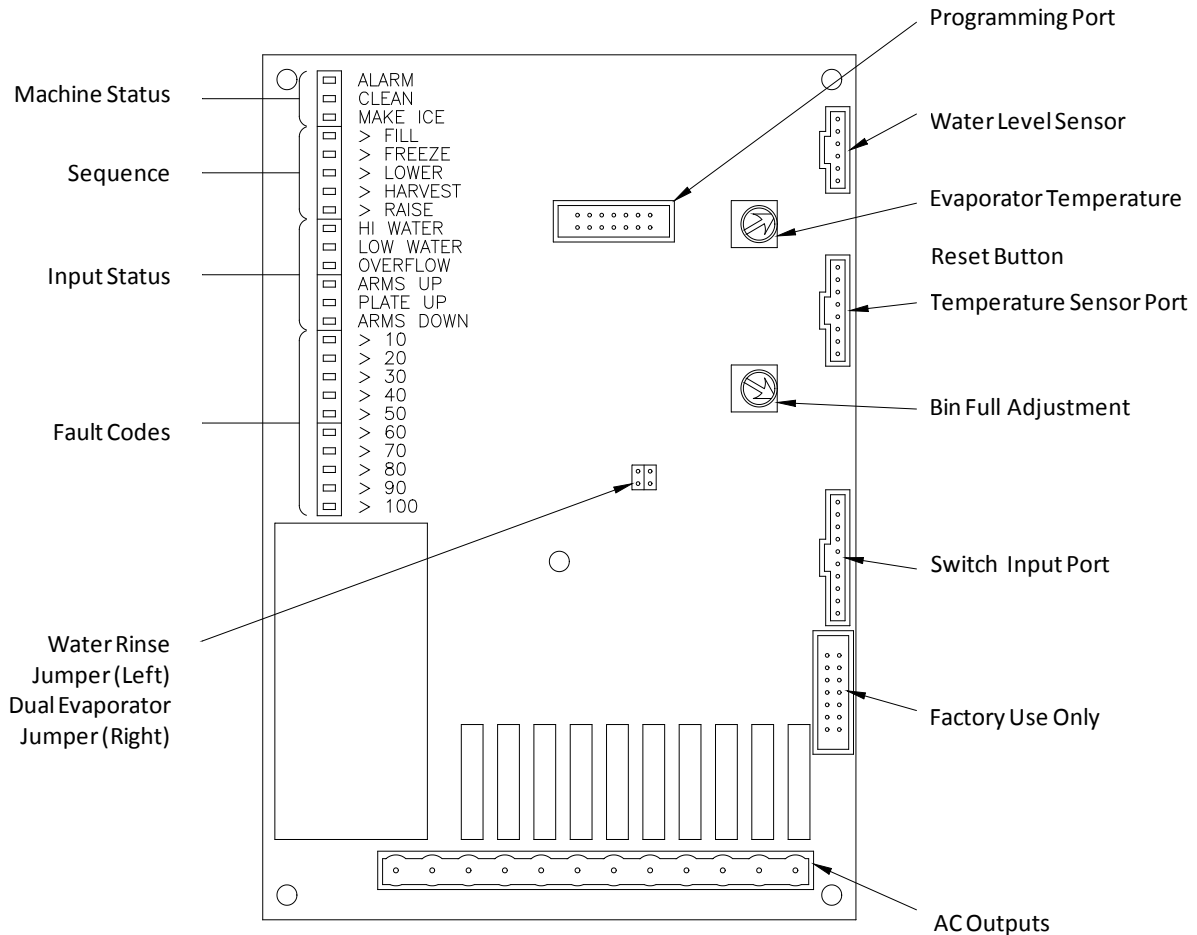

**Machine Status:** Displays the position of the Ice/Clean switch or an Alarm.

**Sequence:** Displays the current stage of the ice making process. (See Page 28 for more information)

**Input Status:** Displays the status of the individual sensors for the ice making process.

**Fault Codes:** The electronic control will monitor for the following conditions and shut down the ice machine as required to prevent damage to the equipment.

**>10 Rev 1.1, 1.2, 1.3, 1.4, 1.5** at any time the evaporator temperature exceeds 120F the controller will shut down the ice maker and provide LED fault indicators.

**Rev 1.6 and higher fault 10 removed**

**>20 Rev 1.1, 1.2, 1.3, 1.4, 1.5** If the water tray automatically cycles 3 times in a row due to a water plate obstruction the controller will shut down the ice maker and provide LED fault indicators.

**Rev 1.6 and higher After 3 consecutive failed attempts at raising the water plate, the machine will defrost in 5 minutes then try again. Led20 will flash during the 5 minute defrost. Machine will shut down if it fails after this defrost period.**

**>30 Rev 1.1, 1.2,** If the Freeze cycle exceeds 60 minutes the controller will shut down the ice maker and provide LED fault indicators.

**REV 1.3, 1.4, 1.5, 1.6** If the Freeze cycle exceeds 45 minutes three times in a row the controller will shut down the ice maker and provide LED fault indicators.

**Rev 1.63 and higher Reworked: Now flashes after 3 consecutive cycles over 35 minutes, but will not shut down the machine. Stops flashing once a cycle is under 35 min.**

- >40 Rev 1.1, 1.2, 1.3, 1.4, 1.5** If the Freeze cycle lasts less than 5 minutes 3 times in a row before an automatic harvest the controller will shut down the ice maker and provide LED fault indicators.  
**Rev 1.6 and higher** After 3 consecutive occurrences of fault 40 the machine will attempt to remove any blockages by defrosting and cycling water – LED40 will be flashing (5Hz) during this defrost and water cycle-defrost will last for 5 minutes – Water will cycle for 10 minutes –if the machine has 3 more consecutive short freeze cycles, LED 40 will be solid and the machine will shut down.
- >50 Rev 1.1, 1.2, 1.3, 1.4, 1.5** If the Harvest cycle exceeds 20 minutes the controller will shut down the ice maker and provide LED fault indicators.  
**Rev 1.6 and higher** Fault 50 Removed Ice Mode –Added a Max defrost time (5 minutes) –Ice maker will attempt to begin a new cycle after 5 minutes of defrost or when the Evaporator Temp. Probe reaches the set temperature.
- >60 Rev 1.1, 1.2** If the Fill cycle exceeds 5 minutes the controller will shut down the ice maker and provide LED fault indicators.  
**REV 1.3 and higher** Water fill exceeds 3 minutes then the Valve closes & waits 10 minutes, as LED60 Flashes. Valve then opens & tries again. This routine repeats 3X and results in a solid Code 60, if the fill is not completed on the third try.
- >70 Rev 1.1, 1.2** If the evaporator temperature during the Fill cycle is less than 31F the controller will energize the Defrost Valve until the evaporator temperature reaches 41F and provide a temporary LED fault indicator.  
**REV 1.3** Both Arm-Up/Arm Down (Cam ) Switches Closed (un-actuated ) at the same time (not allowed ).
- >80** Indicates that the machine is in full rinse mode (left jumper pulled)
- >90** Indicates **bin full**, Ice machine will be shut down after current batch is complete.

#### **REV 1.70**

**ICE MODE and CLEAN MODE: WATER WILL NOW HIT HIGH PROBE, THEN TURN ON WATER PUMP( WATER VALVE OFF ) AND THEN REFILL TO HIGH PROBE.**

**CHANGED HIGH AND LOW WATER DEBOUNCE**

**-0.5 –SECOND DELAY NOW APPLIES WHEN RETURNING TO THE FILL STATE**

**-ENTIRE FILL ROUTINE WILL NOT BE REPEATED IF RETURNING TO THE FILL STATE FROM THE HI WATER DEBOUNCE STATE, ONLY REFILLING TO THE HI WATER PROBE**

**-0.5-SECOND DELAY NOW APPLIES WHEN RETURNING TO THE FREEZE ( ICE MODE )**

**OR CIRULATE ( CLEAN MODE STATE**

#### **REV 1.80**

**ADDED SECONDARY FILL-ONCE THE FLOAT SWITCH REACHES THE HIGH POINT THE WATER PUMP(S) WILL START, WATER LEVEL WILL DROP AND THEN REFILL TO THE HIGH POINT AGAIN.**

**ADDED A 10 SECOND DELAY, BEFORE PLATE DROPS TO EMPTY EXCESS WATER IN WATER TANK.**

Note:

- The controller will need to be reset to clear these error codes.
- Board Revision numbers are found on the sticker placed on a processor chip in the middle of the control board. Example: K4B-1.2 indicates a board revision number 1.2

**Stacked Jumpers:**

- Under normal operation all machines will have a jumper across the left pins. If this jumper is removed the water valve will stay energized to thoroughly rinse the water plate during the water plate lowering, harvest and water plate rising cycles.

Note: The machine will need reset for the controller to acknowledge this change.

- The right jumper is used to tell the controller when it is being used on a dual evaporator machine (GB1064 models only). This is set at the factory and should never be removed.

**Programming Port:** Used by service technicians to alter or up date the controller software.

**Water Level Sensor:** Port for water level sensor probes or FLOAT.

**Evaporator Temperature Adjustment:** To increase the temperature of the evaporator at which the water plate closes, turn this dial counterclockwise. To decrease, turn the dial clockwise. The operator can adjust the harvest termination temperature between 35 and 60F.

Note: After adjustment the controller must be reset.

**Reset Button:** Reboots the controller.

**Temperature Sensor Port:** For evaporator and bin temperature sensor probes.

**Bin Full Adjustment:** To increase the temperature at which the ice level probe reacts to contact with ice in the bin turn the dial clockwise. To decrease, turn the dial counterclockwise. The temperature range for this adjustment is between 33 and 45F.

Note: After adjustment the controller must be reset.

**Switch Input Port:** For the on/off, ice/clean and limit switches

**Factory Use Only:** Used to display diagnostic codes to a LCD monitor used only by service the factory.

**Output:** AC output for powering the fan(s), compressor, water pump(s), actuator motor(s), contactor(s), and valves.



## ERROR-CODE TROUBLESHOOTING

-Before troubleshooting, first check the Control Board and verify your software Revision Level (Rev. 1.1, 1.2, or 1.3)-

CODE:	FAULT CODE INDICATES:	POSSIBLE CAUSE:	SOLUTION:
10>	(Rev. 1.1/1.2/1.3) Evaporator temp over 120F.	<ol style="list-style-type: none"> <li>1. Bad Evaporator Probe (shorted) or wiring.</li> <li>2. Hot Gas Valve stuck open- Cuber stuck in extended harvest mode.</li> <li>3. Bad Control Board.</li> <li>4. Actuator Motor won't raise the Water Plate.</li> </ol>	<ol style="list-style-type: none"> <li>1. Repair/replace wiring or replace Probe.</li> <li>2. Pull down the Water Plate and verify the Hot Gas Valve closes after the Water Plate closes. Repeat, with power to the Hot Gas Valve coil disconnected. If Hot Gas Valve does not close, replace it.</li> <li>3. Replace Control Board.</li> <li>4. Replace Actuator Motor. (Motor never raises Plate to actuate Plate Switch, so HGV stays open &amp; Evap temp rises &gt; 120F.</li> </ol>
20>	(Rev. 1.1) Water Plate failed to close after three consecutive attempts.  (Rev. 1.2/1.3) After 3 attempts to close, machine goes into a 30-minute shutdown, with the Plate open. It will repeat <u>this routine</u> (w/ the Plate closing 3 times & then a 30-minute wait) <u>four times</u> , before going out on Code 20. The Code 20 LED will <u>flash</u> as this routine is in process, and then light <u>solid</u> after the routine tries 4 times and ends Code 20.	<ol style="list-style-type: none"> <li>1. Cam Arm or Cam Pin is broken.</li> <li>2. Cam Spring disengaged or broken.</li> <li>3. Plate-Up Switch stuck open or not actuating.</li> <li>4. Over-freeze causing ice to stick to water plate.</li> <li>5. Silicone coating on Water Plate worn away.</li> <li>6. During harvest, the Evaporator Probe is out of adjustment (reads too warm) or is defective.</li> <li>7. Arms-Up Switch stuck closed- Plate stays down.</li> <li>8. Bin Probe is out of position</li> </ol>	<ol style="list-style-type: none"> <li>1. Replace Cam Arm or Cam Pin.</li> <li>2. Reinstall springs or replace as needed.</li> <li>3. Adjust switch actuator or replace as needed. Check to insure that the Plate-Up switch actuates before the Arms-Up switch actuates.</li> <li>4. Lower the short water level probe, in 1/16" increments, until cubes have a pea-sized dimple in the center.</li> <li>5. Replace the Water Plate if the factory coating is severely worn and is causing ice to stick to it. Use a Food-Grade Silicone spray to provide a temporary improved surface, until the water plate can be replaced.</li> <li>6. Adjust Evaporator Probe colder (turn CW), or replace if adjustment does not help.</li> <li>7. Free up, adjust or replace stuck/shorted Arms-Up Switch, or repair wiring.</li> <li>8. Re-position or replace Bin Probe.</li> </ol>
<b>CODE:</b>	<b>FAULT CODE</b>	<b>POSSIBLE CAUSE:</b>	<b>SOLUTION:</b>

<b>INDICATES:</b>			
30>	(Rev 1.1/1.2)		
	Freeze time exceeds <u>60 min.</u>		
30>	(Rev 1.3)		
	Freeze time exceeds <u>45 min.</u> three times consecutively.		
30>		<ol style="list-style-type: none"> <li>1. Not enough air or liquid flow through condenser.</li> <li>2. Low-level (harvest) probe shorted or touching side of glass tube.</li> <li>3. Inoperative water pump.</li> <li>4. Refrigeration problem.</li> <li>5. Bad Contactor (Compressor would be off!)</li> <li>6. Inlet Water Valve stuck open. Water Tank will be overflowing.</li> <li>7. Controller not shutting off Water Valve.</li> <li>8. Hot Gas Valve (HGV) stuck partially open, or with a liquid-cooled compressor, HGV stuck fully open, but Evaporator never gets hot enough (&gt;120F) to give an Error Code 10.</li> </ol>	<ol style="list-style-type: none"> <li>1. Reset high-pressure safety, if tripped. Clean the condenser, on air-cooled units. Check water/coolant supply, on liquid-cooled units.</li> <li>2. Check/repair shorted wiring to this probe, or gently move probe away from glass surface. Make sure probe is not pushed up/down out of vertical adjustment when moving it away from glass.</li> <li>3. Unplug the pump and confirm the impeller is not jammed with foreign material. Put machine in Wash Mode &amp; check voltage at pump-cable connector. On the Controller Board's AC output bus, check wires P5-2 and P5-6, during Wash Mode, for line voltage. If rated line voltage is present, and the pump's impeller is not obstructed, replace faulty Water Pump.</li> <li>4. Check for low refrigerant charge.</li> <li>5. Replace Contactor.</li> <li>6. Replace Water Valve.</li> <li>7. Replace Controller.</li> <li>8. Replace Hot Gas Valve.</li> </ol>
40>	(Rev 1.1/1.2/1.3)		
	Freeze time less than 5 min., for 3 consecutive times. (Water level in the glass Probe Tube is prematurely falling below the low-level probe, during the first 5 minutes of the freeze cycle, or, the Low-level probe circuit is open.)		
40>		<ol style="list-style-type: none"> <li>1. Slushing, in Pump, water lines or Water Tank, due to Expansion Valve mis-adjustment or <u>not</u> being wrapped in insulating foam, or failure.</li> <li>2. Low-level Probe circuit is open, or the Water-level Probe Assembly is bad.</li> <li>3. Water is being lost somewhere (leaking), causing premature harvest to occur.</li> <li>4. During harvest, Evaporator Probe out of adjustment (too Warm).</li> <li>5. High-level Probe possibly short circuiting during fill, causing short fill and hollow cubes.</li> </ol>	<ol style="list-style-type: none"> <li>1. Ensure Expansion Valve (TXV) is covered with insulating foam, Adjust TXV as needed. As a starting point, <u>gently</u> turn the TXV in CW direction until it stops, then turn it CCW 5-1/2 turns. Adjust in ¼ turn increments as needed.</li> <li>2. Repair wiring to Low-level Probe or replace Probe assembly.</li> <li>3. Inspect hoses, water tank, water pumps, water plate and water level probe assembly to locate leak, repair or replace bad part as needed.</li> <li>4. Adjust colder (CW).</li> <li>5. Locate &amp; repair short circuit.</li> </ol>
<b>CODE:</b>	<b>FAULT CODE</b>	<b>POSSIBLE CAUSE:</b>	<b>SOLUTION:</b>

	<p style="text-align: center;"><b>INDICATES:</b></p> <p style="text-align: center;">(Rev 1.1/1.2/1.3)</p>		
50>	Harvest cycle exceeds 20 min.	<ol style="list-style-type: none"> <li>1. Evaporator Temperature Probe out of adjustment (reads too warm), or is defective (open).</li> <li>2. Actuator Motor won't raise Water Plate.</li> <li>3. Actuator Motor won't lower Water Plate.</li> <li>4. Controller is defective.</li> <li>5. Arms-down Switch is stuck open (Lowering) Cam rotates CCW &amp; wraps spring around cam shaft, causing Cam or Spring damage.</li> <li>6. Arms-Down Switch stuck closed (plate supposed to lower, but is staying up.)</li> <li>7. Hot Gas Valve won't open.</li> <li>8. During harvest, Evaporator Probe out of adjustment (reads too cool) or defective. (Ice production may be low!)</li> <li>9. Bad Contactor (Compressor would be off!)</li> </ol>	<ol style="list-style-type: none"> <li>1. On the Controller, adjust Evaporator Probe pot CW, to a colder setting, so that the Water Plate returns to the closed position about 5 sec. after ice releases. If Evaporator Probe is non-responsive, and Actuator motor is confirmed operational, then replace the Evaporator Probe.</li> <li>2. Replace Actuator Motor – (motor should drive up when Water Plate is down &amp; Evaporator Probe is &gt; 38F. (35-45F)).</li> <li>3. Replace Actuator Motor</li> <li>4. Replace Control Board (When Water Plate is down &amp; Evap Probe is &gt; 38F, there should be line voltage to the Actuator Motor, between pins 2 &amp; 8*, on the green output connector of the Controller. If voltage not present, replace the Controller.</li> <li>5. Free up, adjust or replace Arms-Down Switch or repair open wiring.</li> <li>6. Free up, adjust or replace Arms-Down Switch or repair shorted wiring.</li> <li>7. Check power from the controller to the Valve Coil, to determine if problem is electrical or the Valve is just stuck closed. Replace Coil, Controller, wiring or Valve, as required.</li> <li>8. Adjust Evaporator Probe warmer, or replace if not responding.</li> <li>9. Replace Contactor.</li> </ol> <p>(*Check pins 2 &amp; 10, for upper Actuator Motor, on dual-Evaporator machine).</p>
<b>CODE:</b>	<b>FAULT CODE</b>	<b>POSSIBLE CAUSE:</b>	<b>SOLUTION:</b>

	<b>INDICATES:</b>		
60>	(Rev 1.1/1.2)		
	Water fill exceeds 5 min.		
	(Rev1.3)		
	Water fill exceeds 3 min, then the Valve closes & waits 10 min, as Code 60 LED flashes. Valve then opens & tries again. This routine repeats 3X & results in a solid Code 60, if the fill is not completed on the third try.	<ol style="list-style-type: none"> <li>1. Water supply off or major leak in the water tank, or water lines.</li> <li>2. External water filter plugged.</li> <li>3. Water solenoid valve inoperative.</li> <li>4. Upper (short) Probe, in the Water-Level Probe Assy, may have a loose wire connection (open).</li> <li>5. Common (longest) Probe, in the Water-Level Probe Assy, may have a loose connection (open)</li> <li>6. Controller is bad.</li> </ol>	<ol style="list-style-type: none"> <li>1. Turn on water supply or check for leaks.</li> <li>2. Replace, bypass or eliminate external water filter.</li> <li>3. Place in Wash Mode and pull down on water plate, to lower it. On the return up, water valve will energize to fill, until the short probe is reached. If water solenoid valve has power &amp; water, but does not open, replace the valve.</li> <li>4. Verify wire connection is securely crimped on top of probe &amp; back to Controller.</li> <li>5. Verify wire connection is securely crimped on top of probe &amp; back to Controller.</li> <li>6. Replace Controller.</li> </ol>
70>	(Rev 1.1/1.2)	(Rev 1.1/1.2)	
	Evaporator Temperature <31F, during water fill only. (System opens Hot Gas Valve to compensate, until an Evaporator temp of about 38F is reached. This temp range is adjustable from about 35-46F).	<ol style="list-style-type: none"> <li>1. This is not necessarily a fault condition, but could indicate that the incoming water temp is very cold, which can slow down ice production, as the Hot Gas Valve continuously reopens to warm the Evaporator to &gt;38F.</li> </ol>	<ol style="list-style-type: none"> <li>1. No action required. (Increase incoming water temp to &gt;45F for best results)</li> </ol>
	(Rev 1.3)	(Rev 1.3)	
	Both Arm-Up/Arm-Down (Cam) Switches Closed, (un-actuated) at the same time (Not allowed).	<ol style="list-style-type: none"> <li>1. Switches are loose.</li> <li>2. Switches are mis-wired.</li> <li>3. Switch Bracket bent &amp; switches not in position.</li> <li>4. Switch <u>Cams</u> loose and/or in the wrong position.</li> <li>5. Arms-Up Switch stuck closed – Plate stays down.</li> <li>6. Arms-Down Switch stuck closed – Plate stays up.</li> </ol>	<ol style="list-style-type: none"> <li>1. Tighten switches.</li> <li>2. Wiring should be to the Common &amp; Normally Closed (NC) positions, with black wire to the bottom-<u>front</u> NC terminal and red wire to the bottom-<u>rear</u> NC terminal. White wires should go to the Common terminals on top.</li> <li>3. Straighten bracket.</li> <li>4. Cam flats should be almost opposite each other. See Water Plate Up/Down adjustment, page 41 of Service Manual.</li> <li>5. Replace stuck/shorted Arms-Up Switch or check solutions 2-5 above.</li> <li>6. Replace stuck/shorted Arms-Down Switch or check solutions 2-5 above.</li> </ol>
<b>CODE:</b>	<b>FAULT CODE</b>	<b>POSSIBLE CAUSE:</b>	<b>SOLUTION:</b>

	<b>INDICATES:</b>		
80>	(Rev 1.3 only)	1. This is an optional mode, which is not as energy efficient.	1. Replace jumper to restore normal energy efficient minimum-rinse mode.
	Machine is in Full-Rinse Mode. (Left Jumper is pulled, on Controller)		
90>	(Rev 1.3 only)	1. This is a normal condition, indicating that the Bin is full. (Bin Probe is cold!) 2. If Code 90 is indicated, but Bin is <u>not</u> full, check for faulty Bin Probe, bad wiring to Bin Probe or faulty Controller Board.	1. No action required. 2. Repair wiring, replace bin Probe, or replace Controller.
	Ice Bin Full (A cold Bin Probe will shut down the icemaker right after the next harvest is complete)		

## SEQUENCE OF OPERATION

The following tables describe the general states and sequence of operation for the ice machine models in ice-making mode with an additional table depicting the status when the ice bin is full and the cleaning mode. The charts provide information about the inputs to the controller and the corresponding AC outputs associated with each part of the ice making cycle.

Note:

- Abnormal operation of the ice machine is covered in the Fault Condition section of the manual.
- The sequence of operation for GB106x models is identical to the GB56x and all models utilize the same controller.

Note: GB106x models employ two each of the following electrical components and controls:

- Condenser Fan Motor (air cooled models only)
- Actuator Motor
- Water Pump
- Defrost Valve
- Water Plate Switch
- Arms-Up Switch
- Arms-Down Switch

### Ice Making Sequence

	<b>Step 1 Fill</b>	<b>Step 2 Freeze</b>	<b>Step 3 Lower</b>	<b>Step 4 Harvest</b>	<b>Step 5 Raise</b>
Control	Status	Status	Status	Status	Status
Bin Level Probe	Warm/Not Full	Warm/Not Full	Warm/Not Full	Warm/Not Full	Warm/Not Full
Ice-Clean Switch	Ice	Ice	Ice	Ice	Ice
Contactator	Closed	Closed	Closed	Closed	Closed
Water Plate Switch	Up	Up	Down	Down	Down
Evaporator Temperature Probe	N/A	Cold	Cold	Warming	Warm
Water Level Control	Low Level/Rising	High/Level Falling	Low	Low	Low
Arms-Up/Down Switches	Arms Up	Arms Up	Arms Lowering	Arms Down	Arms Rising
Ice	None	Forming	Fully Formed	Fully Formed	None
Compressor (Condenser Fan)	On	On	On	On	On
Water Plate	Closed	Closed	Opening	Open	Closing
Water Pump	On	On	Off	Off	Off
Defrost Valve	Closed/ De-energized	Closed/ De-energized	Open/ Energized	Open/ Energized	Closed/ De-energized
Water Valve	Open/ Energized	Closed/ De-energized	Open/ Energized	Closed/ De-energized	Open/ Energized
Actuator Motor	Off	Off	On/CCW Rotation	Off	On/CW Rotation
Control Stream	Low	Low to High	Off	Off	Off

## Ice Bin Full/Cleaning Mode

	<b>Ice Bin Full</b>	<b>Cleaning Mode</b>
Control	Status	Status
Bin Level Probe	Cold/Bin Full	Warm or cold
Ice-Clean Switch	Ice	Clean
Contactora	Open	Open
Water Plate Switch	Up or Down	Up
Evaporator Temperature Probe	Warm or Cold	Warm
Water Level Control	Low or High	High*
Arms-Up/Down Switches	Water Plate Up or Down	Water Plate Up
Ice	None or Fully Formed	None
Compressor (Condenser Fan)	Off	Off
Water Plate	Open or Closed	Closed
Water Pump	Off	On
Defrost Valve	Closed	Closed
Water Valve	Closed	Closed*
Actuator Motor	Off	Off
Control Stream	Off	Low

\*Note: If the water level is low, the water valve will open to fill the water tank.

### Description of Each Process

The following sequence begins with the cuber as shipped from the factory with the water plate(s) closed and ready to begin a normal ice making cycle.

**Fill:** The water solenoid valve will be energized only until the water level reaches the high water level probe, and the water pump will run when the water plate is closed.

#### **REV 1.70, 1.8**

**ICE MODE and CLEAN MODE: WATER WILL NOW HIT HIGH PROBE, THEN TURN ON WATER PUMP( WATER VALVE OFF ) AND THEN REFILL TO HIGH PROBE.**

**CHANGED HIGH AND LOW WATER DEBOUNCE**

**-0.5 -SECOND DELAY NOW APPLIES WHEN RETURNING TO THE FILL STATE**

**-ENTIRE FILL ROUTINE WILL NOT BE REPEATED IF RETURNING TO THE FILL STATE FROM THE HI WATER DEBOUNCE STATE, ONLY REFILLING TO THE HI WATER PROBE**

**-0.5-SECOND DELAY NOW APPLIES WHEN RETURNING TO THE FREEZE ( ICE MODE ) OR CIRULATE ( CLEAN MODE STATE**

**Freeze:** Once the water fill cycle has been completed, the water solenoid valve will remain de-energized until the following harvest cycle. The water level in the liquid level probe tube lowers as the water is frozen, but no additional water will be introduced during the freeze cycle. The control stream runs continuously during the freeze cycle with the water returning to the water tank through the hole which can be seen through the control stream box to the left of the dam in the box. The control stream is a "safety valve" to insure the ability to initiate harvest rather than an ice quality control, and it should never need to go over the dam for more than 15 seconds before harvest begins.

Note: No water, other than condensation, should drip or run to the drain pan from the control stream or from the water tank during the freeze cycle. The water level in the liquid level probe tube must get below the level of the low water level probe initiate the harvest cycle. If there is an excess of water in the water tank, the water pump outlet pressure increases when the evaporator cells are full, and the control stream rises and flows over the dam to the drain pan to evacuate the liquid level control tube.

**Lower:** When the water level in the liquid level probe tube is below the low water level probe the controller senses the absence of continuity between the probes. Power is applied to the defrost valve coil allowing hot gas to circulate through the evaporator. The evaporator begins to defrost, and the water plate begins to open immediately. When the cam arm down switch is activated the water plate will stop.

**Harvest:** As long as the evaporator remains cold, the water plate(s) remain in the open position with the water solenoid valve de-energized. The defrost valve remains energized, and the evaporator(s) become warm enough to release the ice which drops by gravity into the ice storage area.

**Raise:** After the ice is out and the evaporator(s) warm to the reset temperature required by the controller the actuator motor(s) will be energized to close the water plate(s) The water solenoid valve will be energized to begin the water fill for the next ice-making cycle, the defrost valve will be de-energized, and the evaporator will begin to cool.

**Ice Bin Full:** When the level of ice reaches the bin probe, the ice maker stops automatically, and it remains off until the bin probe warms up when the ice level is lowered.

Note: in remote condenser models (r), the compressor continues to run after bin control shutdown until the low-side is pumped down to the setting of the pump down controller. This pressure should be between 5 and 10 psig and must never be vacuum.

**Cleaning Mode:** All of the cuber operational components except refrigeration are able to function with the make ice/clean switch in the clean position. Simply placing this switch in the cleaning position does not complete the cleaning and sanitizing of the cuber. Instructions pertaining to the cleaning of a machine can be found on page 11 of this manual.

Note: The frequency of the need for cleaning is determined by the supply water characteristics. The cuber should be cleaned no less frequently than once each 6 months, and it may require more frequent cleaning. The requirement for sanitizing frequency may be contained in local health code regulations.

**Water Plate Closure Problems:** If the plate up switch is not properly actuated, due to mis-adjustment, weak springs, or an obstruction to the water plate travel, such as ice which did not slide off of the plate, the actuator motor will immediately reverse and re-open the water plate.

**Shutdown-High Pressure:** All models are provided with a high pressure cutoff which interrupts power only to the compressor, and to the condenser fan motor if so equipped, when the high-side pressure rises to the cutoff setting. The high pressure cutoff requires manual resetting to restore power in all models. When this happens in air and remote cooled models be sure there is sufficient airflow, a clean condenser, and a properly functioning fan motor. In liquid cooled models make sure the liquid regulator valve is adjusted properly and that there is sufficient flow of coolant.

## **START METHODS**

### **Ice Making Mode Start Up**

**At power up in the ice making mode the electronic control will monitor the following criteria:**

If the evaporator temperature is colder than the Harvest Termination temperature at start up the controller will switch to the Lower state.

If there is an obstruction preventing the water plate from closing the Plate Up switch at startup, the controller will switch to the Lower state.

If the water plate is not in the up position at start up and the evaporator temperature is warmer than the Harvest Termination temperature, the controller will switch to the Raise state.

### **Cleaning Mode Start Up**

**At power up in the wash mode the electronic control will monitor the following criteria:**

If there is an obstruction preventing the water plate from closing the Plate Up switch at startup, the controller will switch to the “Lower” state.

If the water plate is not in the up position at start up, the controller will switch to the “Raise” state.

# GT36X, GT56X, GB56X WIRING DIAGRAM

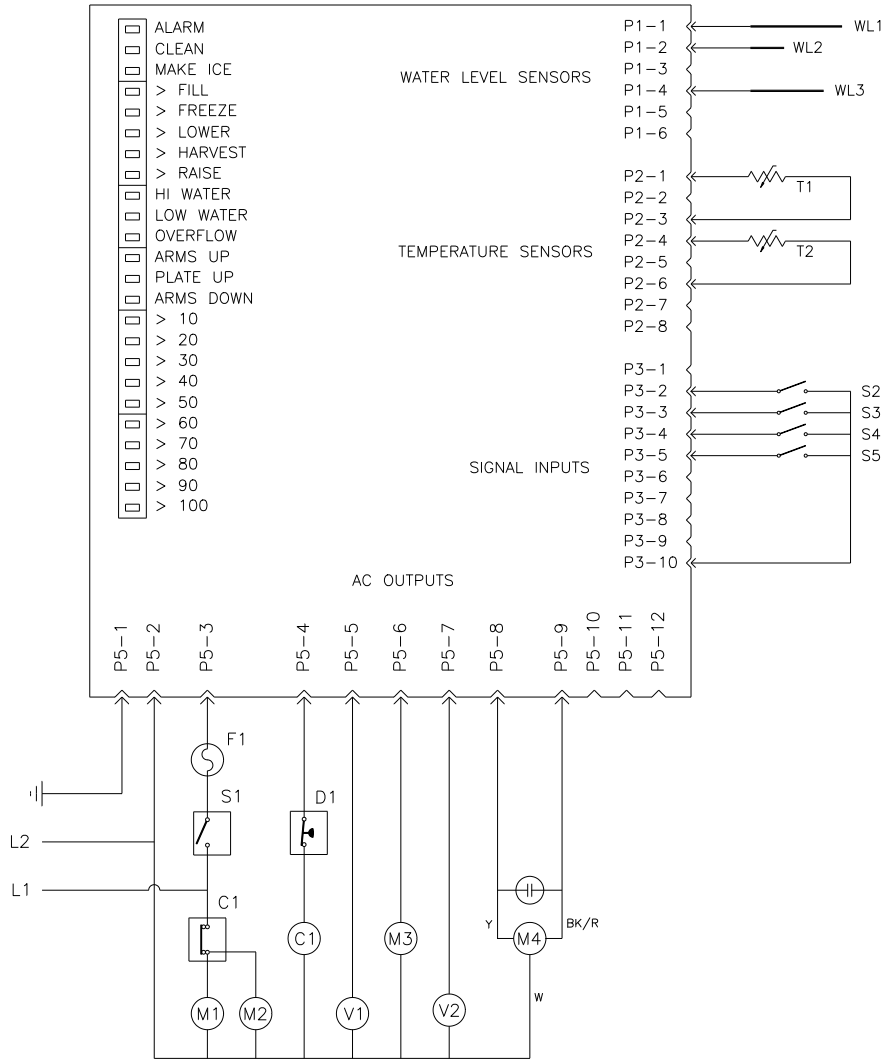

ITEM	DESCRIPTION
C1	CONTACTOR
D1	HIGH PRESSURE CUT-OFF
F1	4A FASTBLOW FUSE
M1	COMPRESSOR
M2	CONDENSER FAN MOTOR (AIR COOLED)
M3	WATER PUMP
M4	ACTUATOR MOTOR
RC1	RUN CAPACITOR
S1	ON-OFF SWITCH
S2	ARMS UP SWITCH
S3	PLATE UP SWITCH
S4	ARMS DOWN SWITCH
S5	ICE-CLEAN SWITCH
SC1	START CAPACITOR
SR1	START RELAY
T1	EVAPORATOR THERMOSTAT
T2	BIN THERMOSTAT
V1	WATER VALVE
V2	DEFROST VALVE
WL1	WATER LEVEL PROBE-REFERENCE
WL2	WATER LEVEL SENSOR-HIGH
WL3	WATER LEVEL SENSOR-LOW

## Compressor Wiring

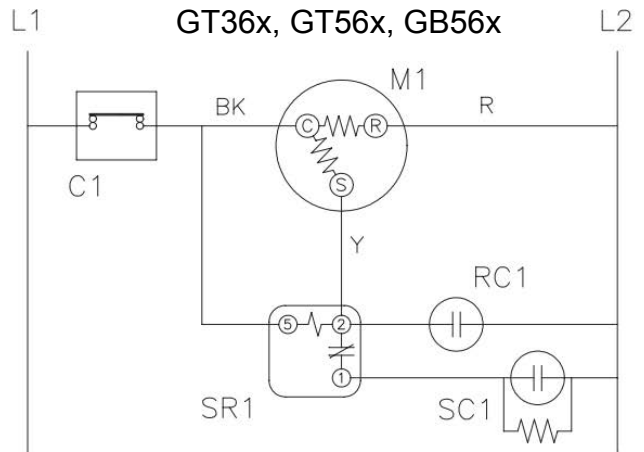
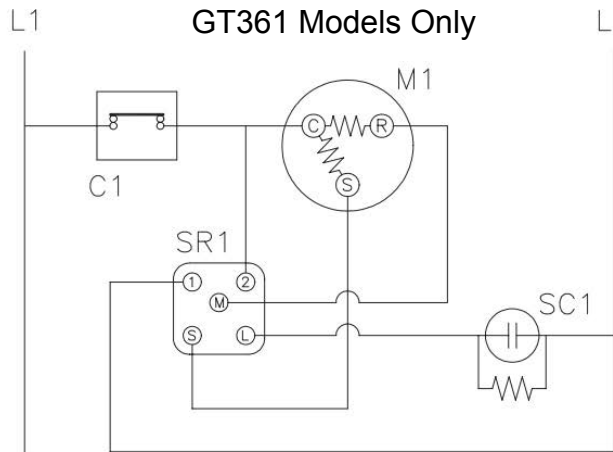

# GB1064 A & L WIRING DIAGRAM

Note: A wiring diagram for remote condenser models (GB106xR) is on the following page.

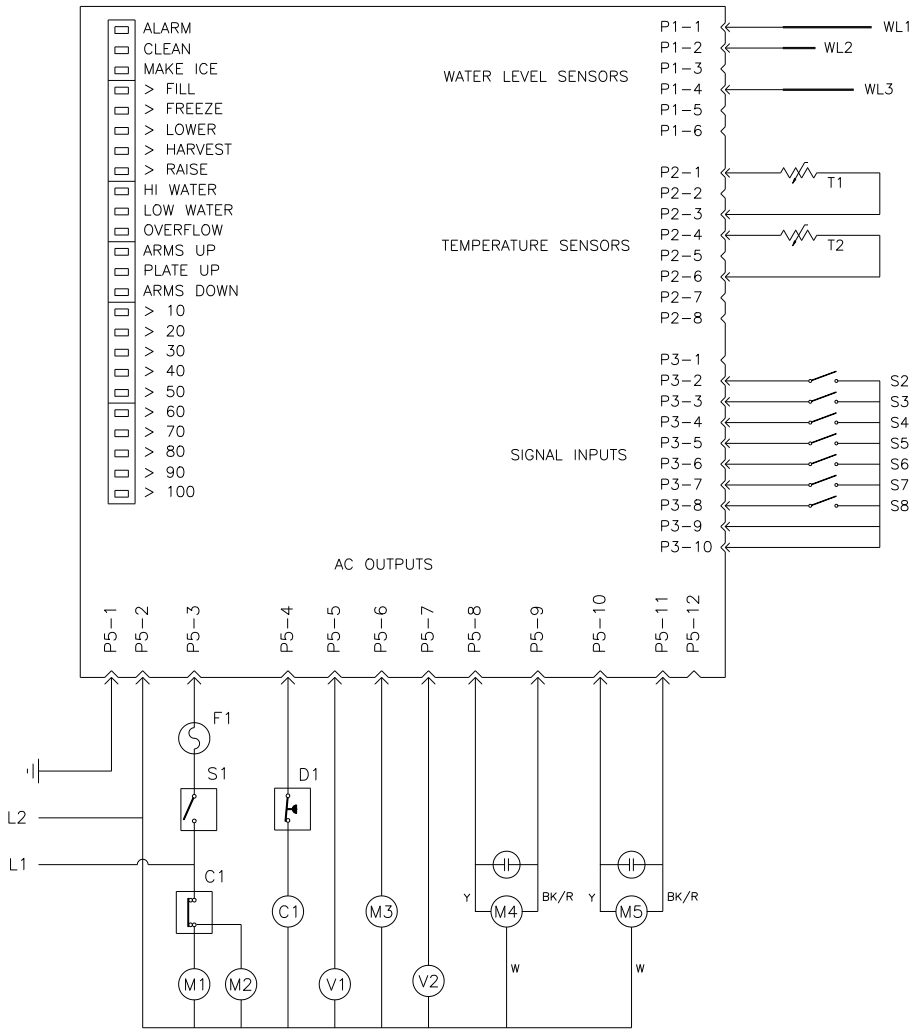

ITEM	DESCRIPTION	
C1	CONTACTOR	
D1	HIGH PRESSURE CUT-OFF	
F1	4A FASTBLOW FUSE	
M1	COMPRESSOR	
M2	CONDENSER FAN MOTOR (2) (AIR COOLED)	
M3	WATER PUMP (2)	
M4	ACTUATOR MOTOR-LOWER WATER PLATE	
M5	ACTUATOR MOTOR-UPPER WATER PLATE	
RC1	RUN CAPACITOR	
S1	ON-OFF SWITCH	
S2	ARMS UP SWITCH	LOWER WATER PLATE
S3	PLATE UP SWITCH	
S4	ARMS DOWN SWITCH	UPPER WATER PLATE
S5	ICE-CLEAN SWITCH	
S6	ARMS UP SWITCH	UPPER WATER PLATE
S7	PLATE UP SWITCH	
S8	ARMS DOWN SWITCH	
SC1	START CAPACITOR	
SR1	START RELAY	
T1	EVAPORATOR THERMOSTAT	
T2	BIN THERMOSTAT	
V1	WATER VALVE	
V2	DEFROST VALVE	
WL1	WATER LEVEL PROBE-REFERENCE	
WL2	WATER LEVEL SENSOR-HIGH	
WL3	WATER LEVEL SENSOR-LOW	

## Compressor Wiring

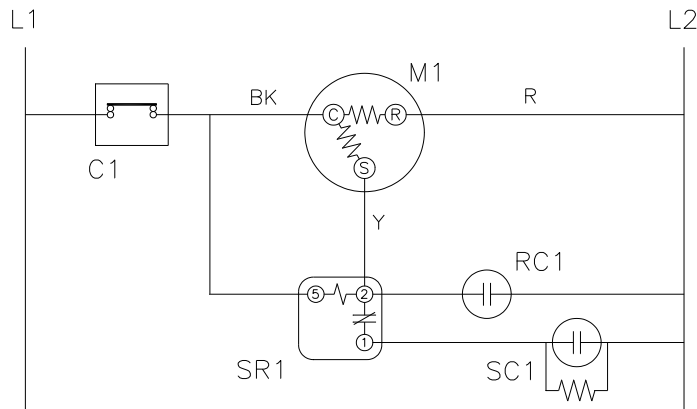

# GB106XR WIRING DIAGRAM

ITEM	DESCRIPTION
C1	CONTACTOR
D1	HIGH PRESSURE CUT-OFF
D2	LOW PRESSURE CUT-OFF (PUMP-DOWN)
F1	4A FASTBLOW FUSE
M1	COMPRESSOR
M2	CONDENSER FAN MOTOR (2) (AIR COOLED)
M3	WATER PUMP (2)
M4	ACTUATOR MOTOR-LOWER WATER PLATE
M5	ACTUATOR MOTOR-UPPER WATER PLATE
RC1	RUN CAPACITOR
S1	ON-OFF SWITCH
S2	ARMS UP SWITCH
S3	PLATE UP SWITCH
S4	ARMS DOWN SWITCH
S5	ICE-CLEAN SWITCH
S6	ARMS UP SWITCH
S7	PLATE UP SWITCH
S8	ARMS DOWN SWITCH
SC1	START CAPACITOR
SR1	START RELAY
T1	EVAPORATOR THERMOSTAT
T2	BIN THERMOSTAT
V1	WATER VALVE
V2	DEFROST VALVE (2)
V3	LIQUID LINE VALVE
WL1	WATER LEVEL PROBE-REFERENCE
WL2	WATER LEVEL SENSOR-HIGH
WL3	WATER LEVEL SENSOR-LOW

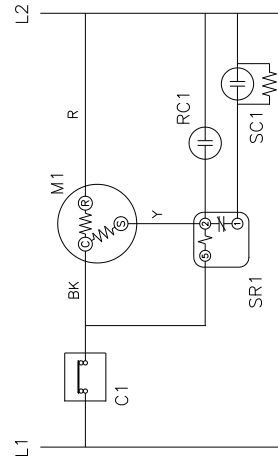
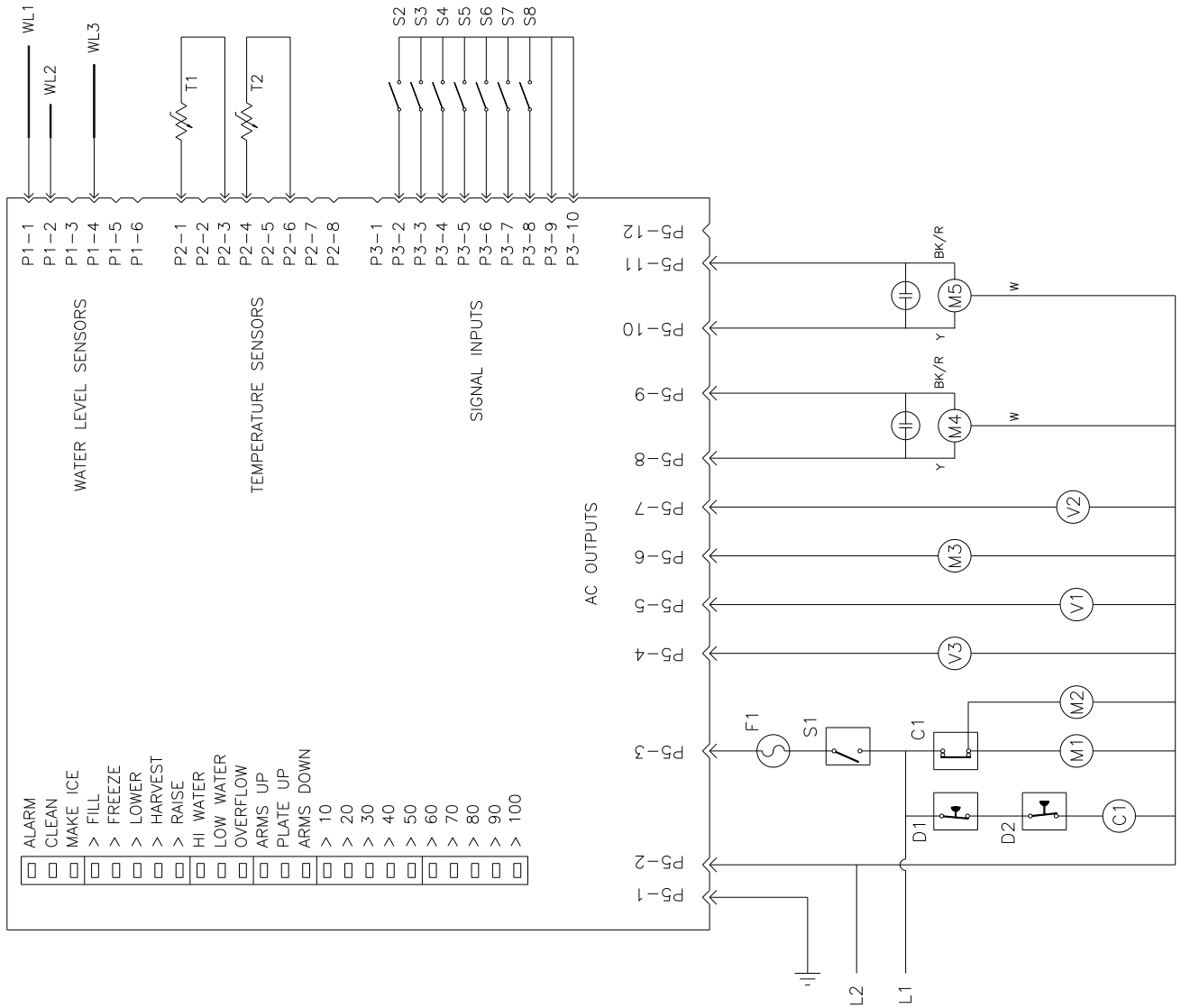

## **COMPRESSOR TEST PROCEDURE**

### ***Warning:***

- Refer all service work to qualified technicians.
- Knowledge of proper installation and service procedures is essential to the safe maintenance of KOLD-DRAFT equipment.
- Do not operate equipment that has been damaged.
- Always disconnect the power supply before servicing the equipment. Some circuits remain energized when the ice machine is switched off.
- Never operate the ice maker with any covers, panels or other parts removed or not properly secured.
- Never modify the circuitry of KOLD-DRAFT equipment from the original specifications.
- Use only genuine KOLD-DRAFT replacement parts.
- Use of non-approved parts when servicing KOLD-DRAFT equipment may create a safety hazard or cause equipment and property damage.
- Use of non-approved parts, when servicing KOLD-DRAFT equipment, will void the equipment warranty.
- Disconnect all electrical power before removing the protective terminal cover.
- Never energize the system unless the protective terminal cover is securely fastened.
- Never energize the system unless the compressor is properly connected to ground.
- Never reset a circuit breaker or replace a fuse without checking for a short circuit to ground. An open fuse or tripped circuit breaker is an indication of a ground fault. Energizing a compressor with a ground fault may cause terminal pin ejection, which will allow oil and refrigerant to spray out of the system. This oil spray, combined with an electrical spark, can ignite causing harm to personnel and property.
- Discharge all capacitors with a 20,000 ohm resistor before working with them or removing them from the ice machine. This must be done to avoid damage to measuring devices and the risk of electrical shock.

**Caution:** Failure to comply with all KOLD-DRAFT service guidelines may cause personal injury, equipment or property damage and voiding of the product warranty.

### **Note:**

- When servicing KOLD-DRAFT ice machine refrigeration systems, all work performed must be consistent with the best refrigeration service practices. These systems must remain clean, dry and properly charged with refrigerant, in order for the ice machine to operate as designed.
- See the Remote Air-Cooled Condenser section of the manual for additional service information related to these ice machines.
- All KOLD-DRAFT ice machine models utilize CSR (capacitor start/capacitor run) compressors. Each model includes a potential start relay, a start capacitor and a run capacitor, in the compressor circuitry, to start and operate these compressors properly and with maximum efficiency. All compressors also include thermal protectors—external on GT36x, GT56x, and GB56x models and internal on GB106x models. This procedure will help diagnose problems with these compressors and all related components.

### **Test Procedure for a Short Circuit to Ground (Ground Fault)**

1. Disconnect all electrical power to the system, making sure all power legs are open.
2. Remove the protective terminal cover. Inspect for evidence of overheating at any connection. Overheating is an indication that a compressor motor problem exists. Disconnect all leads from the terminal pins.
3. Check the compressor for a ground fault using an ohm meter or a high potential ground tester. Connect one lead to the copper suction line and connect the other lead to one of the terminal pins. Repeat this procedure for the two remaining terminal pins. If the instrument indicates any resistance less than 2 mega ohms between any pin and the suction line (compressor housing), a ground fault exists.
4. If a ground fault exists, replace the compressor. Do not reconnect the compressor or re-use any leads or terminal connectors that exhibit signs of overheating.

### **Test Procedure for Continuity and Proper Resistance**

1. If no ground fault has been found, determine if there is an open or short circuited motor winding or if the thermal protector is open.
2. Allow time for the thermal protector to reset. This may take as long as an hour for internal type thermal protectors.
3. For single phase compressors, test the continuity of the start winding by measuring between terminal pins C and S. Test the continuity of the main winding by measuring between terminal pins C and R. If there is no continuity in either winding, replace the compressor.
4. For three phase compressors, test the continuity of the windings by measuring between each pair of terminal pins: 1-2, 2-3 and 1-3. If there is no continuity between any set of terminal pins, replace the compressor.
5. If continuity is found in all motor windings, measure the resistance (ohms) of the windings.
6. For single phase compressors, measure between each pair of terminal pins: C-S, C-R and S-R. The sum of the resistance measured between C-S and C-R should equal the resistance measured between S-R, plus or minus a small deviation. Proper resistance may be confirmed by comparing the measured resistance to the resistance specifications for specific compressor models. If the resistance is not correct, replace the compressor. If the specifications are not found on the ice machine, please contact the factory.
7. For three phase compressors, measure between each pair of terminal pins: 1-2, 2-3 and 1-3. The resistance measured between each pair of pins should always be greater than zero and within 10% of one another. Proper resistance may be confirmed by comparing the measured resistance to the resistance specifications for specific compressor models. If the resistance is not correct, replace the compressor. If the specifications are not found on the ice machine, please contact the factory.

## **Test Procedure for Compressor Electrical Components**

1. Testing The Potential Relay:
2. Before testing the relay, be sure it is the one specified for use with the ice machine compressor and the mounting position of the relay is correct.
3. Measure for continuity between terminals 5 and 2—if there is no continuity, replace the relay.
4. Measure for continuity between terminals 2 and 1—if there is no continuity, the contacts are open and the relay must be replaced.
5. The relay may also malfunction if the supply voltage is 10% higher or lower than the rated voltage or if the relay is loosely mounted, allowing it to vibrate or if it is used in conjunction with an incorrect start capacitor.

### **Testing the Run Capacitor:**

1. Before testing the run capacitor, be sure it is the one specified for use with the ice machine compressor.
2. After making sure the capacitor is discharged, disconnect it and test the value with a capacitance meter. If the measured value is more than 10% higher or lower than the rated value, replace the run capacitor.
3. The capacitor may also malfunction if the supply voltage is more than 10% higher than the rated voltage.

### **Testing the Start Capacitor:**

1. Before testing the start capacitor, be sure it is the one specified for use with the ice machine compressor.
2. After making sure the capacitor is discharged, disconnect it and test the value with a capacitance meter. If the measured value less than the rated value or more than 20% higher than the rated value, replace the start capacitor.
3. As an alternative, test the run capacitor by determining if there is continuity across the terminals. Use a meter set to the R x 1 scale. If there is continuity the capacitor is shorted and must be replaced.
4. Another alternative is to set the meter to the R x 100,000 scale. If there is no needle deflection on an analog meter when placing the probes across the capacitor terminals or if infinite resistance is indicated on a digital meter, the capacitor is open and needs to be replaced.
5. The capacitor may also malfunction if the relay contacts are not working properly, or if the capacitor is subjected to prolonged operation of the start cycle, because the start relay is incorrect, the starting load is too high, or the supply voltage is more than 10% lower than the rated voltage.

### **Additional Service Information**

- Testing the External Thermal Protector:
- After allowing sufficient time for the thermal protector to reset, disconnect it and test for continuity across the terminals. If there is no continuity, replace the thermal protector.
- Disconnect and test the compressor wiring by confirming that there is continuity between relay terminal 5 and compressor terminal C and also between terminals 2 and S as well as 4 and R.
- Replace the potential relay if all other tests do not reveal the problem. A new relay will eliminate any electrical problems that cannot be determined with the previous testing. If a new relay does not correct the operation, the compressor may have a mechanical problem.

Note: Excessive short cycling may be caused by a faulty thermal protector, but it also may be caused by other malfunctioning system components such as the bin thermostat, Ice-Off-Wash switch, and contactor or high pressure cut-out.

## WATER PLATE REPLACEMENT

1. Turn off water and open plate until cams are in the 9:00 position then turn off the power.
2. Remove the control stream drain hose.
3. Remove water level probe assembly by sliding it to the right beyond the control stream box and lift. Disconnect tube assembly from main tank.
4. Remove the pump mounting screw holding the water plate brace, the inlet, and outlet hoses from the pump.
5. Pry plastic hinge brackets away from the plate.
6. Unhook the main springs from the water plate.
7. Remove the screws that mount the control module box. Pull the module forward to disconnect front cam.
8. Slide the water plate and tank to the right without turning and slide it forward out of the machine.
9. Remove the spring bosses, water plate brace, water deflector, pressure pads and the four screws holding the tank to the water plate. Remove plastic bolt from shoulder on water plate and place in new plate.
10. Attach the tank to new water plate with two #6 mach. screws on the left side and two #10 sheet metal screws on the front and back.
 

**Note:** The speed nuts on the front and back holes are no longer required.
11. With the open end of the water plate to the right, slide it back into the machine and to the left of its normal position.
12. Hook up the main springs to the water plate, rear spring first.
13. Hook on and snap into place the plastic hinge brackets
14. Secure the pump mounting screw holding the water plate brace.
15. Remove the water level probe assembly and reposition the control stream drain tube. Position and secure the control module box to mounting bracket. Check adjustment of plastic lift bolt. Reconnect harvest switch, if present.
16. Water plate must be aligned with the evaporator per drawing illustration.

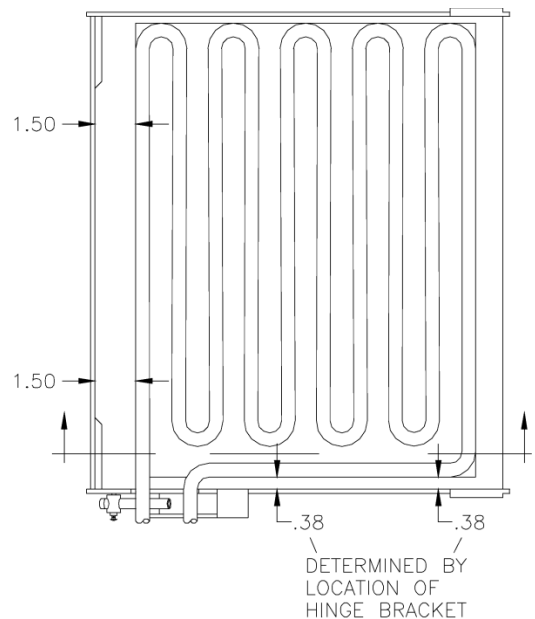

CLEARANCE SPECIFICATION:  
 .075" FULL CUBE "C" & HALF CUBE "HK"  
 CHECK CLEARANCE ALL CORNERS

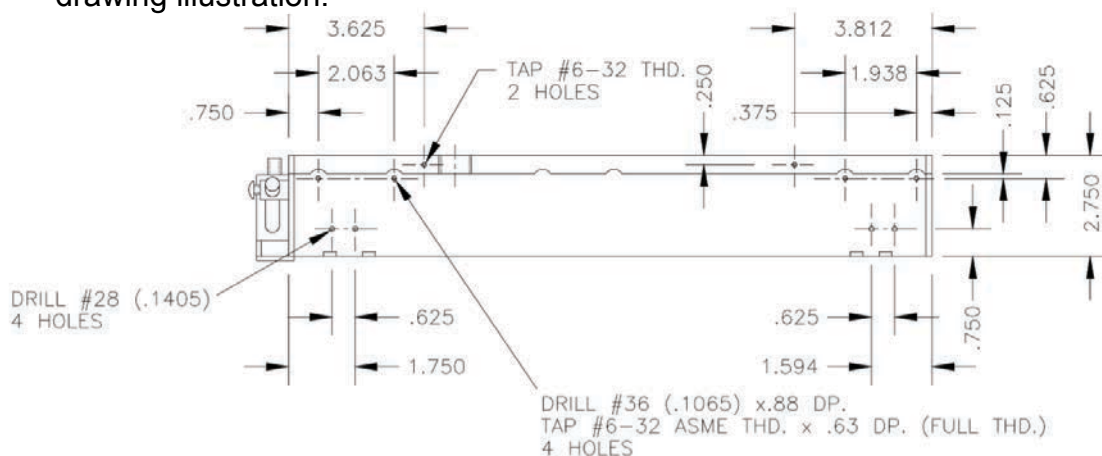
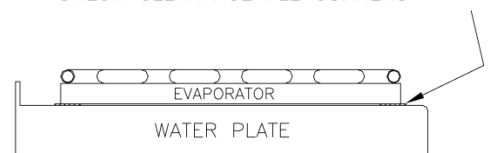

## WATER PLATE ALIGNMENT

If the water plate is not aligned with the evaporator, the cubes may appear cloudy or misshapen.

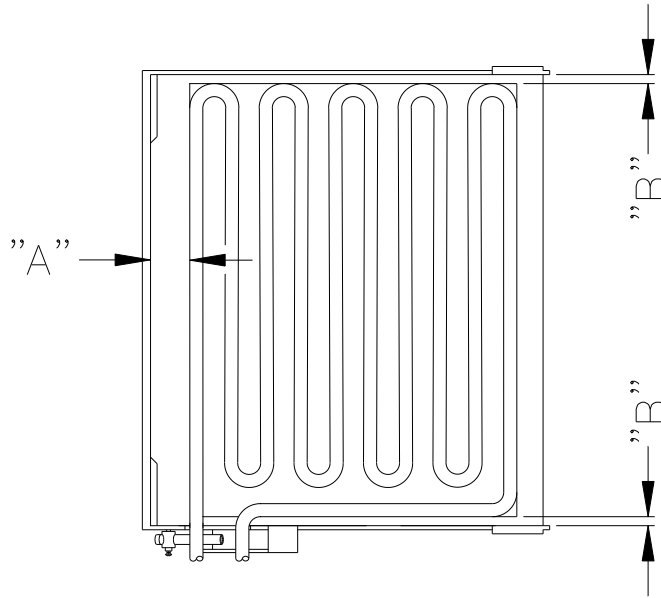

Dimension "A" is not adjustable. If this dimension is out of tolerance, the evaporator or water plate mounting components may be damaged.

Adjustments to dimension "B" can be made by sliding the front and rear hinges along the left edge of the water plate. Lightly tap the hinges as required to align the water plate with the evaporator. Alignment is correct when the space between the evaporator and the water plate is equal in front and in back.

**"A" = 1.5" ± 3/32" (38 mm ± 2.5 mm) "B" = 5/16" ± 1/16" (8 mm ± 1.5 mm)**

## WEB THICKNESS ADJUSTMENT

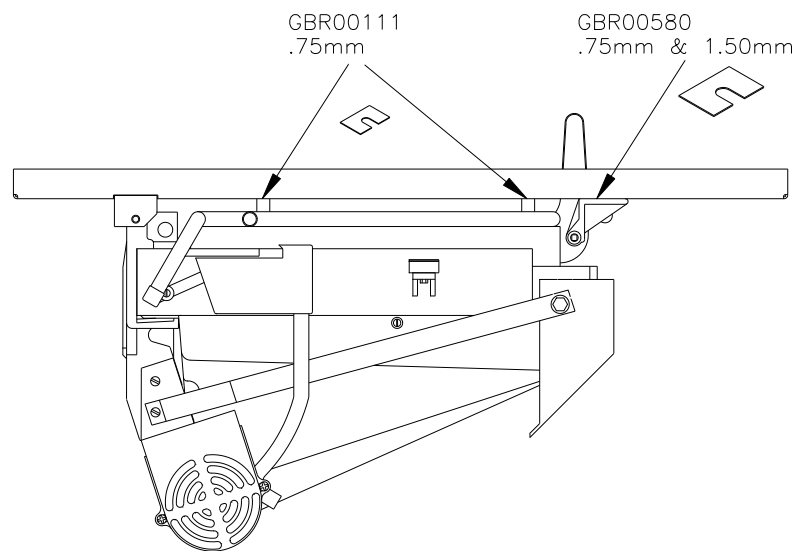

The web thickness between cubes (the gap between the bottom of the evaporator and the water plate surface) can be adjusted by inserting or removing shims between the support channels and the evaporator support posts or the cam shaft bearing brackets. Loosen the actuator motor mounting screws before inserting or removing shims between the channels and cam shaft bearing brackets. The web thickness specification for both C and HK models is 1/16" (2mm)

## WATER PLATE UP/DOWN POSITION AND ADJUSTMENT

When the water plate is up (closed), the spring end of the cam arm must be in the 12 o'clock position, with the spring on the left side of the cam arm hub. The arms up switch lever (front) will be down and the arms down switch lever (back) will be up. When the water plate opens, the cam arm turns counter clockwise until the arms down switch operator allows the arms down switch lever to drop. When the water plate is fully down (open), the cam arm should be in the seven o'clock position; the spring should be aligned with the cam arm. When closing again, the cam arm will turn clockwise, until the arms up switch operator allows the arms up switch lever to drop.

The positions of the cam arms, when the water plate is open and closed, may be adjusted by loosening the set screws and rotating the switch operators as required. Baseline positions of the switch operators for the front and back are 11 and 4 o'clock when the water plate is up. When the water plate is down, positions for the front and back switch operators are 6 o'clock and 11 o'clock. Note: The front operator is for adjusting the arms up switch and the back operator is for adjusting the arms down switch.

### Up Position

- If the cam arm in the up position is too far clockwise from 12 o'clock rotate the front switch operator clockwise to stop the arm's rotation earlier
- If the cam arm in the up position is too far counterclockwise from 12 o'clock rotate the front switch operator counterclockwise to stop the arm's rotation later
- If the cam arm in the down position is too far clockwise from 7 o'clock rotate the back switch operator clockwise to stop the arm's rotation later
- If the cam arm in the down position is too far counterclockwise from 7 o'clock rotate the back operator counterclockwise to stop the arm's rotation earlier

Note: Component relationships and/or operation, other than described, indicate component failure, maladjustment or improper reassembly when servicing the ice machine.

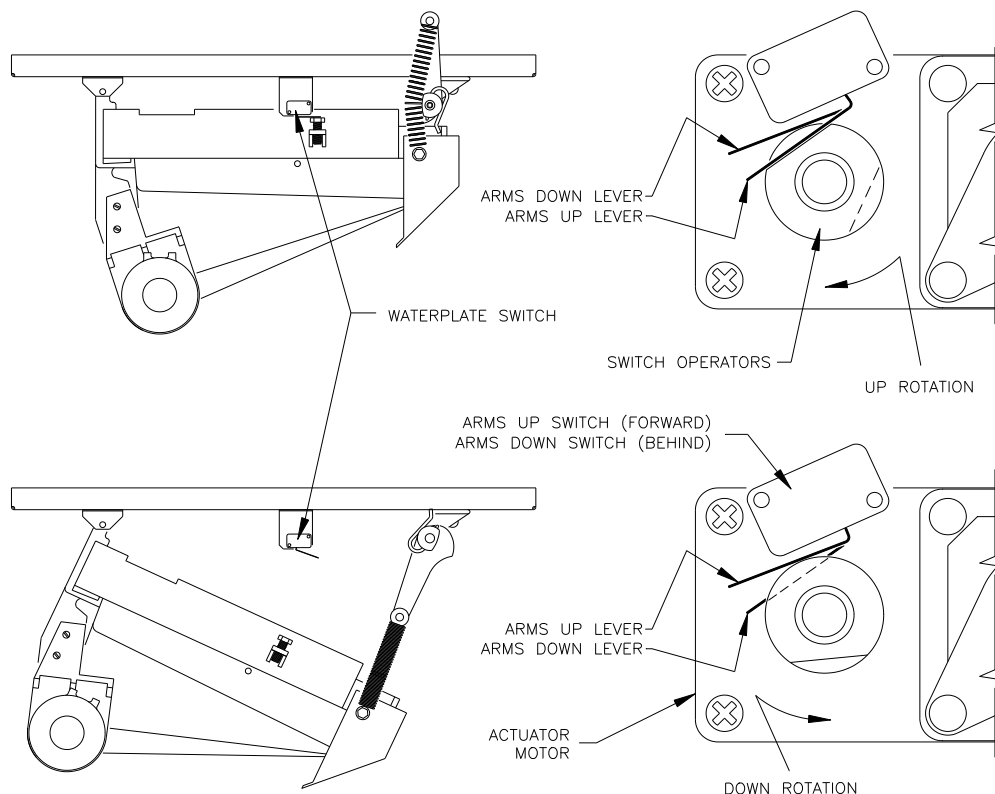

## ACTUATOR MOTOR ELECTRICAL TESTS

The following tests are for troubleshooting the actuator motor and related circuits:  
Use an AC voltmeter set for the proper range. Voltages in the tables are measure across the motor reversing capacitor (between the colored motor lead wires.

If there is no ice in the evaporator(s) and the water plate(s) is (are) not fully closed (with the water plate switch(es) pushed up and the "ARMS UP" LED on), the actuator motor(s) and pump(s) should be running. If not, be sure there is power to the motor(s) and also that the motor(s) is(are) not overheated and off due high temperature. Allow the motor to cool down before starting the test procedure.

**Always refer to the proper wiring diagram when troubleshooting.**

Motor winding resistances at 75° F (24° C) out of the circuit are as follows:

REX 115 volt motors, white to black or yellow, approximately 95 ohms

REX 230 volt motors, white to red or yellow, approximately 400 ohms

### **Voltages for Actuator Motor Electrical Tests**

Actuator Motor Test Parameters			
Voltage Reading	Capacitor	Motor	Remedy
115 volt motors, reads 180-240 or 230 volt motors, reads 290-370	Good	Good	Tap gear case to align bearings
Line voltage for any voltage motor	Open	Good	Replace capacitor
Line voltage for any voltage motor in one actuator switch position and 0 volts in the other position	Open and →	One motor winding open	Replace capacitor and
115 volt motors, reads 180-240 or 230 volt motors, reads 290-370 in one actuator switch position and 0 volts in the other position	Good	One motor winding open	Replace motor
0 volts in both actuator switch positions. Be sure there is power to the motor (line voltage) by leaving one probe on either capacitor lead and placing the other probe on the white motor lead.	Shorted or →	Both motor windings open	Disconnect the actuator motor from the circuit and test the winding resistance. If approximately 500 ohms from white to red or yellow, replace the capacitor. If the resistance is erratic, replace the motor.

## **PROBE TEST PROCEDURE**

### **Water Level Probes:**

Water level probes can be tested at any temperature and are good if they exhibit continuity (0 ohms resistance) along the length, between the probe wire and the connector at the controller.

It is advisable to flex the probe at the two connections, while testing for continuity, to eliminate the possibility of an intermittent failure.

### **Evaporator Temperature and Ice Level Probes:**

The evaporator temperature probe and the ice level probe are designed to have a nominal resistance of 5650 ohms at 32° F (0°C). To test these probes they must be placed in ice water 32°F (0°C) for a minute and then checked for resistance while the tube is still in the ice water. A probe is considered good if it exhibits a resistance value between 5400 and 5900 ohms at 32° F (0°C). Probes with values outside this range should be replaced.

## **FOR GB1064 MACHINES BUILT BEFORE 607945**

### **WATER FILL ADJUSTMENT INSTRUCTIONS**

Note: This applies **only for GB1064 machines** with serial numbers **before 607945**. Machines built after 607945 have an upgraded water valve which equalizes the amount of water in each tank per load.

Since supply pressures vary between the factory and install locations, water fill levels between the top and bottom water tanks will also vary. The water fill difference between the upper and lower water tanks should be less than 1/8 in (3 mm). A dynamic water pressure of 30 psig (0.2 MPA) minimum is required to ensure consistent water fill performance. Before adjusting the water fill levels be sure that the Water Level Probes are properly adjusted and no hoses are kinked. Refer to the Service Manual for the adjustment specifications according to cube size.

#### **To Adjust For Equal Fill:**

1. Place the selector in the “CLEAN” mode, switch the Power Switch to “ON”.
2. Pull down on the right side of either water plate, stretching the springs until the actuator motors rotate the cam arms counter-clockwise. Observe that the cam arms continue to turn, opening the water plates fully, dumping the water in the tanks. It may be necessary to turn the power off with the water plates fully open in order to completely drain the water tanks. At this point, the cam arm rotation will reverse and close the water plates. The cam arm rotation will stop when the water plates are fully closed and the water fill will occur. When the fill water reaches the “high-level probe” the water fill valve is de-energized and the water fill stops. A small amount of water will drain back from the water fill tubing to the lower water tank.
3. Compare the water levels in the probe tube and the upper section control stream overflow as seen on the next page to determine if the upper and lower water tanks are filling within the specified maximum difference
4. If the top tank level is lower than the bottom tank level by more than 1/8 inch (3 mm) for “C” models and 1/4 inch (6 mm) for “HK” models, squeeze the restrictor clamp to reduce the bottom tank fill rate. If the top tank level is more than 1/8 inch (3 mm) for “C” models and 1/4 inch (6 mm) for “HK” models 1/8” higher than the lower tank level, open the restrictor clamp to increase the lower tank fill rate. Small adjustments are recommended. When the adjustment appears to be correct, dump the water by pulling down on a water plate, as above, allow the water tanks to fill again and re-check the levels.



<b>TROUBLE SHOOTING</b>		
<b>Problem</b>	<b>Possible Cause</b>	<b>Solution</b>
Ice machine is not operating.	On-Off switch in "Off" position	Move switch to "On" position.
	No power at ice machine. Circuit protector open.	Replace fuse or reset breaker. Check circuit for overload condition.
	Ice machine off because bin is full of ice.	Use ice or move ice away from bin level probe.
	Ice machine off because bin level probe is defective.	Replace bin level probe.
	Ice machine off as if bin is full. Ambient temp below 50°F (10°C).	Ambient temperature must be 60°F (15°C) minimum.
Compressor is not operating. Water pump and other components are operating normally.  See compressor test procedure for more information.	Ice-Clean switch in "Clean" position.	Move switch to "Ice" position.
	High pressure cut-out open on air cooled models. Condenser dirty.	Clean condenser and reset high pressure cut-out. Confirm proper operating pressures.
	High pressure cut-out open on air cooled models. Air circulation through condenser is insufficient or hot air is recirculating through the condenser.	Provide adequate spacing between the ice machine and walls, ceilings or other equipment. See installation instructions for spacing requirements. Confirm proper pressures.
	High pressure cut-out open on liquid cooled models. Coolant liquid interrupted or insufficient	Restore adequate coolant liquid supply and reset high pressure cut out. Confirm proper operating pressures.
	High pressure cut-out open on liquid cooled models. Interior of condenser has a mineral build-up.	Clean or replace condenser.
	High pressure cut-out open. Refrigeration system is overcharged.	Remove refrigerant and recharge the system to specifications.
	Compressor thermal protector open because of low voltage condition.	Allow thermal protector to reset. Measure voltage at contactor while compressor is running. Correct power supply problem if voltage is lower than specified on the ice machine electrical plate. See compressor test procedure for more information.
	Compressor thermal-protector open because of defective run capacitor.	Replace run capacitor. See compressor test procedure for more information.
	Contactor is defective.	Check for voltage at coil terminals. Replace contactor if it does not close when the coil is energized.
	Compressor start capacitor or relay defective	Test and replace these parts if defective. See compressor test procedure for more information.

<b>TROUBLE SHOOTING</b>		
<b>Problem</b>	<b>Possible Cause</b>	<b>Solution</b>
	Compressor is defective.	Replace compressor. See compressor test procedure for more information.
Condenser fan motor is not operating on air-cooled models. Compressor is operating	Fan motor protector open.	Replace motor if it does not run when cool or at normal operating conditions.
	Fan motor defective	Replace motor.
Defrost performance slow	Condenser sub-cooling >11°C at the middle point of the freeze cycle on liquid-cooled models.	System is overcharged with refrigerant. Remove refrigerant and recharge the system to specifications.
	Condenser liquid regulating valve not closing fully during defrost on liquid-cooled models.	Adjust, repair or replace liquid regulating valve.
	Air cooled ice machine installed in a low ambient temperature location.	Ambient temperature must be 60°F (15°C) minimum.
	Ice frozen into the water plate surface. Thick web between ice cubes.	Adjust web thickness to specifications.
	Ice frozen into the water plate surface. Cubes are fully formed without small dimples.	Reduce the water fill level until ice cubes are produced with small dimples.
	Ice cubes have large dimples or are hollow at the end of the freeze cycle. Batch weight is too light.	Increase the water level until ice cubes are produced with small dimples.
	Evaporator grids are distorted.	Carefully straighten grids or replace evaporator if the damage is severe.
Water plate re-opens immediately after closing	"Water plate up" switch lever is not being pushed up completely.	Adjust "water plate up" switch actuator on water plate until it pushes up the switch lever completely.
	Water plate is prevented from closing by some obstruction such as ice remaining on the water plate surface.	Eliminate obstruction. Adjust the evaporator temperature probe so all ice is out of the evaporator before the water plate begins to close.
Water plate closes but re-opens before water fill is completed.	Water plate springs are stretched or weak and allow the water plate to drop slightly as the water fills the tank. The "water plate up" switch lever is allowed to drop and re-open the water plate.	Replace defective springs.
	A water plate spring is broken or disconnected from the cam arm or the water plate.	Replace broken spring or reattach disconnected spring.

<b>TROUBLE SHOOTING</b>		
<b>Problem</b>	<b>Possible Cause</b>	<b>Solution</b>
Water plate will not close after defrost.	Evaporator temperature probe is defective and not sensing warm evaporator temperature.	Test probe and replace if defective.
	Actuator motor output shaft is tuning but front cam is not turning.	Cam pin is broken or missing.
	Actuator motor will not run. No voltage measured at actuator motor.	Inspect operation of arms up and arms down switches. Adjust or replace if defective.
	Actuator motor will not run. No voltage measured at actuator motor and controller output terminal.	Test controller and replace if defective.
	Actuator motor will not run. Voltage measured at actuator motor. Actuator motor or capacitor defective.	Replace defective actuator motor or capacitor. See actuator motor test procedure for additional information.
	Actuator motor overheated. Open thermal overload.	Let motor cool and determine why motor is running continuously.
Defrost does not initiate when water level drops below low water level probe.	Water level probe does not sense that the water level is low.	Be sure there is no continuity path between the probes through water or mineral deposits on the probe cap. Make sure the cap is clean and dry especially after cleaning the ice machine.
	Water level probes are OK but no voltage measured at the controller output terminals to the actuator motor, water valve or defrost valve.	Test controller and replace if defective.
Defrost cycle ends and water plate closes before all ice is out of the evaporator.	Evaporator temperature adjustment is set too cold and terminates defrost too early.	Adjust evaporator temperature adjustment counter-clockwise (warmer) to extend defrost time.
	The evaporator temperature probe has poor contact with the evaporator and terminates defrost too early.	Be sure the evaporator temperature probe is fully inserted into the evaporator probe holder.
	Evaporator grids are distorted, slowing the fall of the ice from the evaporator.	Carefully straighten grids or replace evaporator if the damage is severe.

<b>TROUBLE SHOOTING</b>		
<b>Problem</b>	<b>Possible Cause</b>	<b>Solution</b>
Defrost valve opens during water fill.	Slow water fill.	The water supply pressure must be a minimum of 5 PSI (34 KPA) dynamic at the water valve. Be sure that the supply line is of adequate size. This is especially important for liquid cooled models where the potable water and condenser coolant water are supplied by the same water line. Check for restrictions in the water supply line including clogged filters. Check the water line strainer and clean it if needed.
	Cold potable water supply.	This is normal operation of the unit, if the water supply is too cold. Very cold water will not rinse the ice residue from the water plate, causing it to build up and affect normal operation.
Ice remains attached to the water plate surface at the end of defrost.	Ice frozen into the water plate surface. Thick web between ice cubes.	Adjust web thickness to specifications.
	Ice frozen into the water plate surface. Cubes are fully formed without small dimples.	Reduce the water level until ice cubes are produced with small dimples.
	Over-freezing	Be sure that the control stream does not go over the dam for longer than 15 seconds.
	Cold potable water supply.	Very cold water will not rinse the ice residue from the water plate thoroughly.

<b>TROUBLE SHOOTING</b>		
<b>Problem</b>	<b>Possible Cause</b>	<b>Solution</b>
Water valve will not close. Potable water level continues to rise after contacting the tip of the high water level probe, during the fill cycle.	No voltage measured at water valve coil. Water valve remains open because of water supply problem.	The water supply pressure must be a minimum of 5 PSI (34 KPA) dynamic at the water valve. Be sure that the supply line is of adequate size. This is especially important for liquid cooled models where the potable water and condenser coolant water are supplied by the same water line. Check for restrictions in the water supply line including clogged filters. Check the water line strainer and clean it if needed.
	No voltage measured at water valve coil. Water valve remains open because of dirty or defective water valve.	Disassemble and clean water valve if needed. Make sure the bleed holes in the valve diaphragm are open. Replace water valve if defective.
	Line voltage measured at water valve coil.	Test for continuity through the high level probe and the reference probe. Replace the probe if the continuity is broken.
	Water level probes test OK, but line voltage measured at water valve coil.	Test controller and replace if defective.
Water valve will not open. Potable water level never reaches the high water level reaches the high water level probe, during the fill cycle.	No voltage measured at water valve coil because of an abnormal probe continuity path.	Be sure there is no continuity path between the probes through water or mineral deposits on probes through water or mineral deposits on the probe cap. Make sure the cap is clean and dry especially after cleaning the ice machine.
	Test controller and replace if defective. No voltage measured at water valve coil and controller output terminal because of defective controller.	Test controller and replace if defective.
	Water valve closes when water contacts the tip of the low water level probe, because the low and high water level probes are reversed in the water level probe terminal plug.	Relocate and reinstall the probe wires, in the probe terminal plug or replace the water level probe set.

<b>TROUBLE SHOOTING</b>		
<b>Problem</b>	<b>Possible Cause</b>	<b>Solution</b>
Poorly formed or cloudy ice cubes.	Water plate pressure is low. Pump operating improperly because of low supply voltage.	Measure the supply voltage with the ice machine running. Be sure voltage is within the specified tolerances.
	Water plate pressure is low. Improper pump installed in ice machine.	Be sure the pump being used is proper for the ice machine model.
	Water plate pressure is low. Water plate is cracked or leaking	Repair or replace water plate.
	Ice cubes have large dimples or are hollow at the end of the freeze cycle.	Increase the water level until ice cubes are produced with small dimples.
	Water plate is out of alignment with evaporator.	Re-align water plate. See the water plate alignment illustration for more information
	Ice cubes do not break apart after defrost because of thick web between cubes.	Adjust spacing between evaporator and water plate. See the web thickness adjustment illustration for more information.
	Ice cubes have uneven dimples. Dimples are larger on right side of evaporator because of low refrigerant charge.	Remove refrigerant and recharge the system to specifications.
	Ice cubes have uneven dimples. Dimples are larger on right side of evaporator because of high evaporator superheat.	Adjust the expansion valve to decrease the evaporator superheat.
	Ice cubes have uneven dimples. Dimples are larger on left side of evaporator and ice may freeze into the right side surface of the water plate because of low evaporator superheat.	Adjust the expansion valve to increase the evaporator superheat.
Actuator motor turns clockwise at start of defrost.	Arms up and arms down switches are defective, or the relationship between the switches and switch operators is improper.	Confirm proper operation of the arms up and arms down switches and replace if needed. Confirm proper settings of the switch operators and adjust as required.
	Arms up and arms down switch wiring is incorrect.	Correct switch wiring.
Cam arms are improperly positioned when the water plate is fully opened and/or closed.	The relationship between the switches and switch operators is improper.	Adjust switch operators so the cam arms are at the 12 o'clock position when the water plate is fully closed and at the 7 o'clock position when the water plate is fully open. See the cam arm, switch and switch operator relationship illustration for more information.



## PARTS DIAGRAMS

### GT36x Parts – Left Side

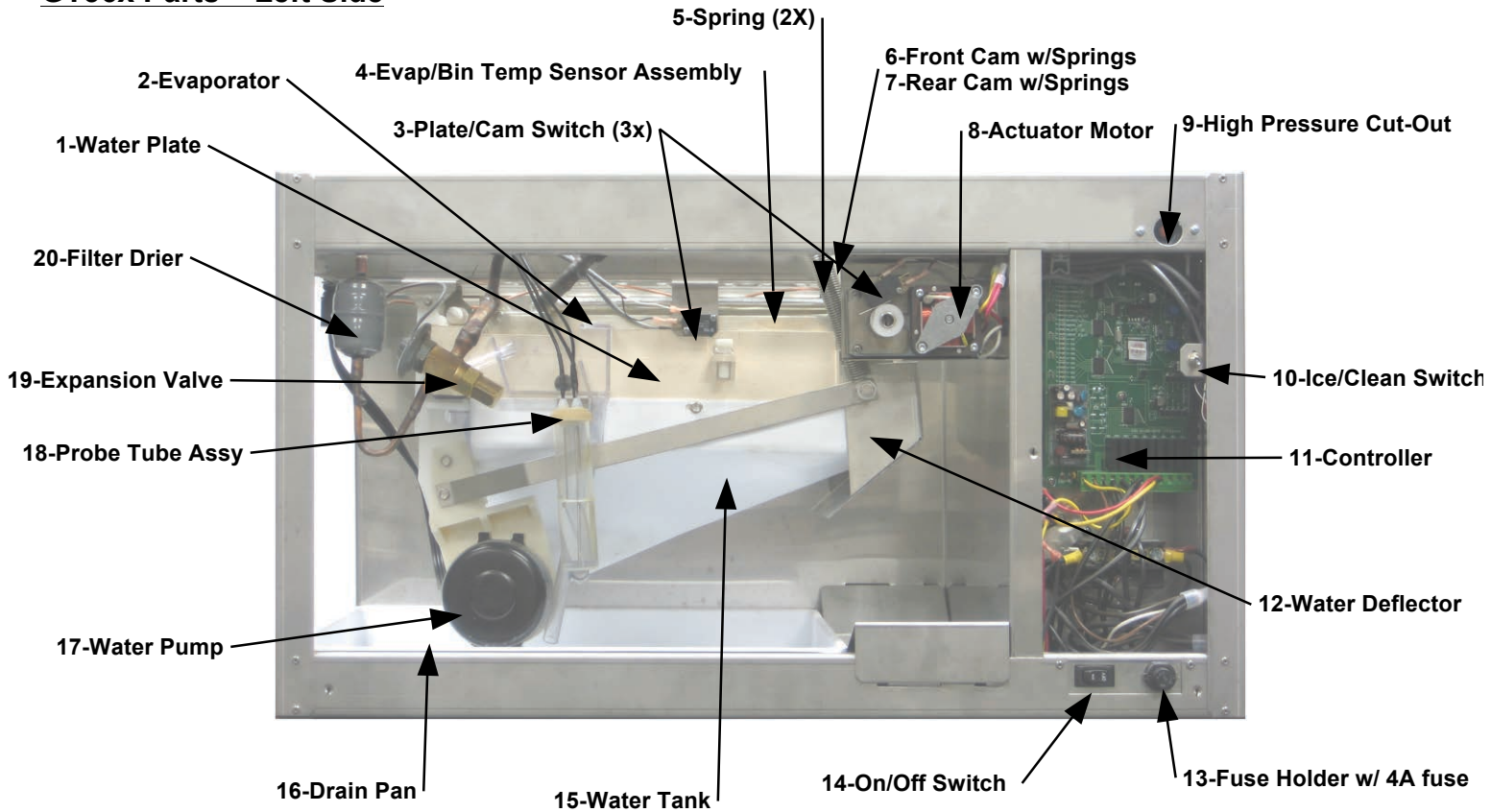

No.	Part Description	Model	Part No.	No.	Part Description	Model	Part No.
1	Water Plate "C"	GT36x	<a href="#">102141501</a>	10	Ice-Clean Switch	All	102138501
	Water Plate "HK"	GT36x	<a href="#">102141601</a>	11	<b>Controller ( PCB 1.8</b>	<b>All</b>	<b><a href="#">102145901</a></b>
2	Evaporator "C"	GT36x	<a href="#">102142101</a>	12	Water Deflector	GT36x	<a href="#">102141001</a>
	Evaporator "HK"	GT36x	<a href="#">102142001</a>	<b>13</b>	<b>Fuse Holder With Fuse 4amp</b>	<b>All</b>	<b><a href="#">102144901</a></b>
3	<b>Cam Switch 2Req'd</b>	<b>All</b>	<b><a href="#">102138001</a></b>		<b>Fuse Only</b>	<b>All</b>	<b><a href="#">102136301</a></b>
	<b>Magnetic Plate Switch-Kit</b>	<b>All</b>	<b><a href="#">102147701</a></b>	14	On-Off Switch	All	<a href="#">102138601</a>
<b>4</b>	<b>Evap./Bin Temperature Probe Assembly</b>	<b>GT36x</b>	<b><a href="#">102143901</a></b>				
<b>4</b>	<b>EVAPORATOR PROBE KIT 1.8</b>		<b><a href="#">102145701</a></b>	15	Water Tank	GT36x	<a href="#">102142301</a>
<b>4</b>	<b>BIN PROBE KIT 1.8</b>		<b><a href="#">102145801</a></b>				
5	Spring 2Req'd	All	<a href="#">GBR00909</a>	16	Drain Pan	GT36x	102142201
6	Cam (Front) with Spring	All	<a href="#">GBR00969</a>	17	<b>Water Pump All GT3,GT5,GB</b>	<b>ALL IM</b>	<b><a href="#">102146305</a></b>
7	Cam (Rear) with Spring	All	<a href="#">GBR00949</a>		<b>Power Supply</b>	<b>GT364</b>	<b><a href="#">102146303</a></b>
8	Actuator Motor	GT361	<a href="#">102140901</a>	18	<b>Water Level Assembly Float</b>	<b>GT36x</b>	<b><a href="#">102146201</a></b>
	Actuator Motor	GT364	<a href="#">102123802</a>	19	Expansion Valve	GT36x	<a href="#">102118802</a>
9	High Pressure Cut-Out (Manual Reset)	All	<a href="#">102105501</a>	20	Filter Drier	All	<a href="#">GBR02750</a>

**GT36x Parts – Right Side-Air Cooled**

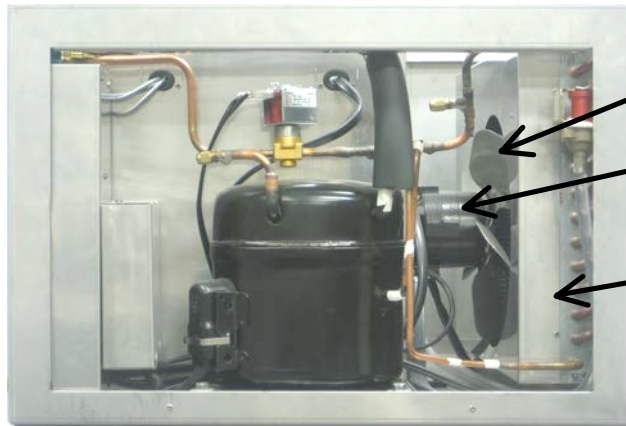

5-Fan Blade

6-Fan Motor

7-Condenser (Air Cooled)

**GT36x Parts – Right Side-Liquid Cooled**

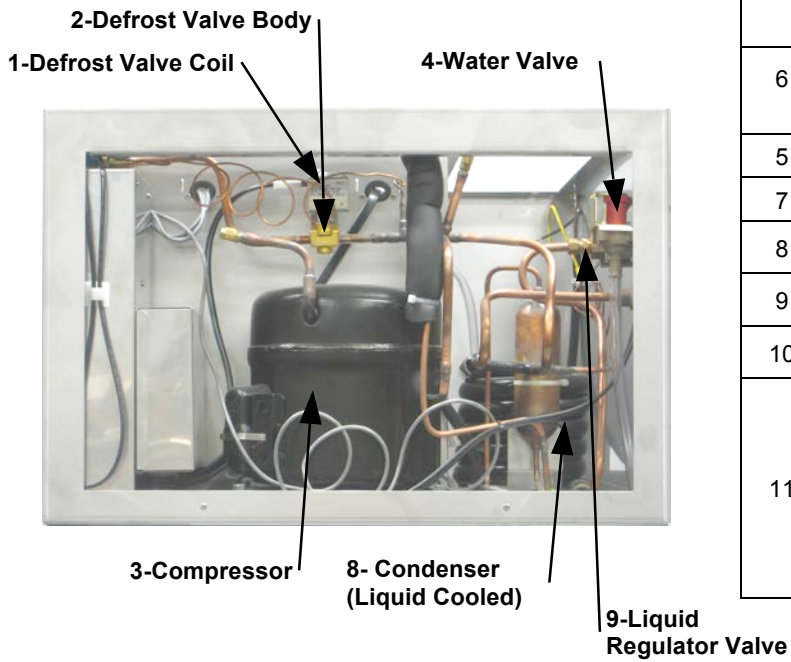

2-Defrost Valve Body

1-Defrost Valve Coil

4-Water Valve

3-Compressor

8- Condenser (Liquid Cooled)

9-Liquid Regulator Valve

No.	Description	Model	Part No.
1	Defrost Valve Coil	GT361	102101101
	Defrost Valve Coil	GT364	102101201
2	Defrost Valve Body	GT36x	102100801
3	Compressor	GT361	102140701
	Compressor	GT364	102141701
4	Water Valve-Before S/N 607945	GT361	102138301
	Water Valve-Before S/N 607945	GT364	102138401
	Water Valve-After S/N 607945	GT361	102141201
	Water Valve-After S/N 607945	GT364	102141101
6	Fan Motor	GT361	102139201
	Fan Motor	GT364	102139301
5	Fan Blade	GT36x	102101602
7	Condenser (Air Cooled)	GT36xA	102141901
8	Condenser (Liquid Cooled)	GT36xL	102102101
9	Liquid Regulator Valve	GT36xL	GAR00701D
10	Relay Box Assembly	GT361	102142401
11	Relay Box – Components		
	Relay Potential	GT364	102145101
	Start Capacitor		102119502
	Run Capacitor		102104401

## GT56x Parts – Left Side

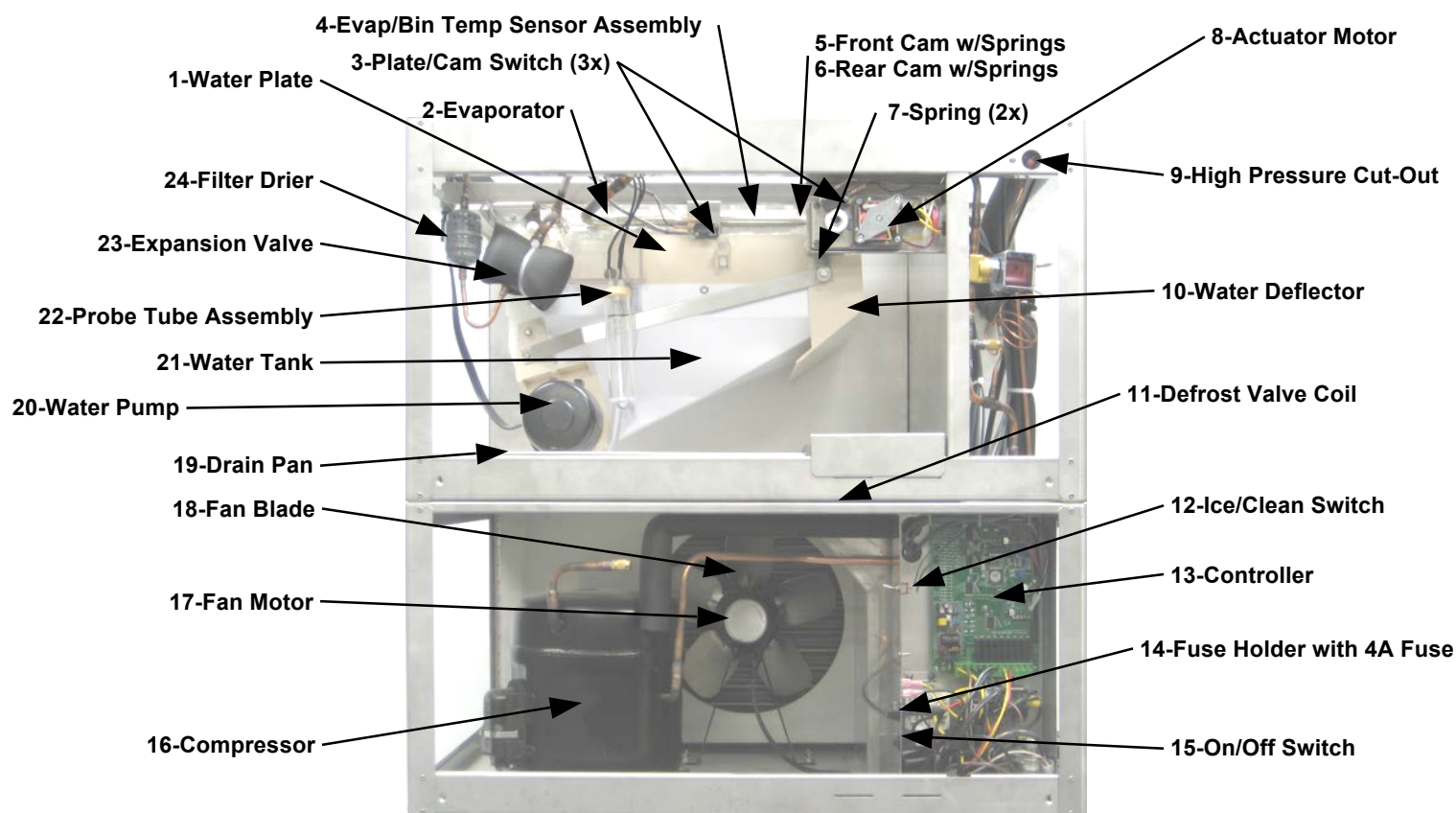

No.	Part Description	Model #	Part No.	No.	Part Description	Model #	Part No.
1	Water Plate "C"	GT56x	<a href="#">GBR00200</a>	12	Ice/Clean Switch	All	102138501
	Water Plate "HK"	GT56x	<a href="#">GBR00270</a>	13	<b>Controller ( PCB 1.8 )</b>	<b>All</b>	<a href="#">102145901</a>
2	Evaporator-"C" After S/N 608887	GT56x	102144501	14	<b>Fuse Holder With 4A Fuse FUSE ONLY</b>	<b>All</b>	<a href="#">102144901</a> <a href="#">102136301</a>
	Evaporator-"HK" After S/N 608887	GT56x	102144601	15	On/Off Switch	All	102138601
	Evaporator-"k"	GT56x	102147201	16	Compressor	GT561	102119128
	Bin/Evap. Combo	GT56x	102143901		Compressor	GT564	102119131
3	<b>Cam Switch (2)</b>	<b>All</b>	<a href="#">102138001</a>	17	Fan Motor	GT561	<a href="#">102139201</a>
	<b>Magnetic Plate Switch</b>	<b>All</b>	<a href="#">102147701</a>		Fan Motor	GT564	102139301
4	<b>Evap. Probe 1.8</b>	<b>GT56x</b>	<a href="#">102145701</a>		18	Fan Blade	All
	<b>Bin Probe 1.8</b>	<b>GT56x</b>	<a href="#">102145801</a>	19	Drain Pan	GT56x	102137801
5	Front Cam w/Springs	All	<a href="#">GBR00969</a>	20	<b>Water Pump All GT3,GT5,GB</b>	<b>ALL IM</b>	<a href="#">102146305</a>
6	Rear Cam w/Springs	All	<a href="#">GBR00949</a>		<b>Power Supply</b>	<b>GT564</b>	<a href="#">102146303</a>
7	Spring (2 per PK )	All	<a href="#">GBR00909</a>	21	Water Tank	GT56x	102143301
8	Actuator Motor	GT561	102123801				
	Actuator Motor	GT564	102123802	22	Water Fill Assembly Float	GT56x	102146201
9	High Pressure Cut-Out	All	102105501	23	Expansion Valve	GT56x	GBR02359
10	Water Deflector	GT561	<a href="#">GBR00202</a>	24	Filter Drier	All	<a href="#">GBR02750</a>

**GT56x Parts -Right Side**

Water valve in same location on “A” and “L” models.

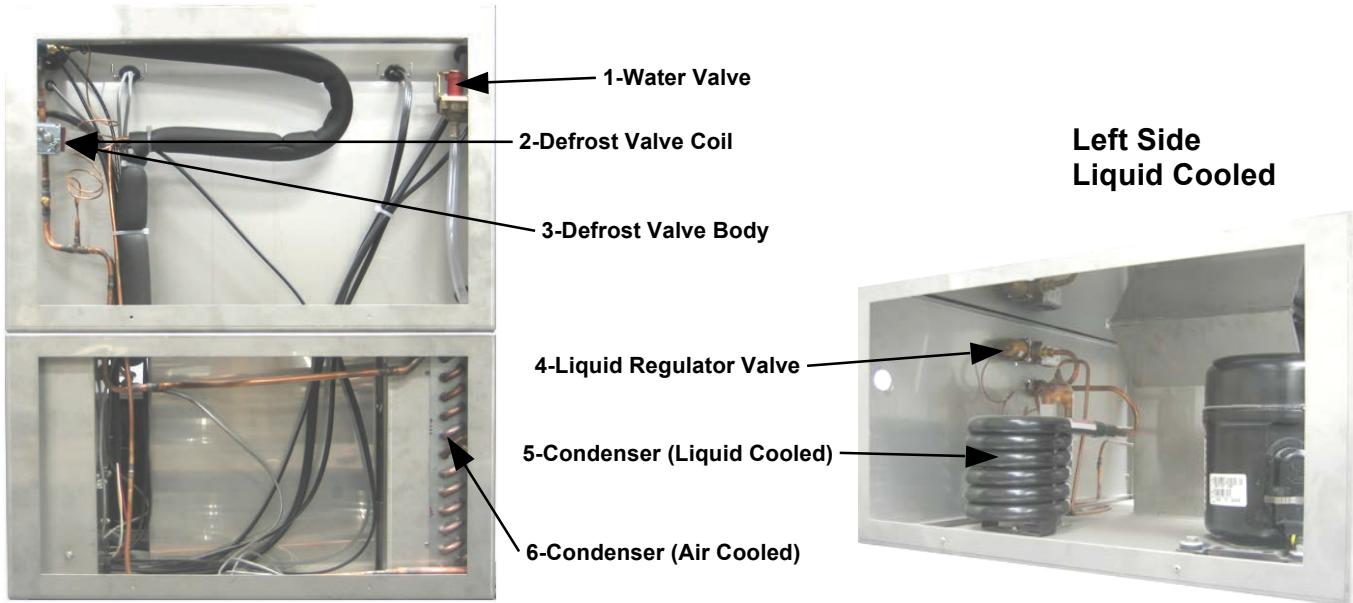

**GT561**

**RUN CAP-102119704**

**START CAP-102119508**

**START RELAY-**

**102104709**

**GT564**

**RUN CAP-102104401**

**START CAP-**

**START RELAY-**

**102104706**

No.	Description	Model(s)	Part No.
1	Water Valve-115V Before S/N 607945	GT561	102138301
	Water Valve-115V After S/N 607945	GT561	102141201
	Water Valve-230V Before S/N 607945	GT564	102138401
	Water Valve-230V After S/N 607945	GT564	102141101
2	Defrost Valve Coil	GT561	102101101
	Defrost Valve Coil	GT564	102101201
3	Defrost Valve Body	GT56x	102101001
4	Liquid Regulator Valve	GT56xL	GAR00701D
5	Condenser-Liquid Cooled	GT56xL	102102101
6	Condenser-Air Cooled	GT56xA	102101803

**102119502**

# GB56x

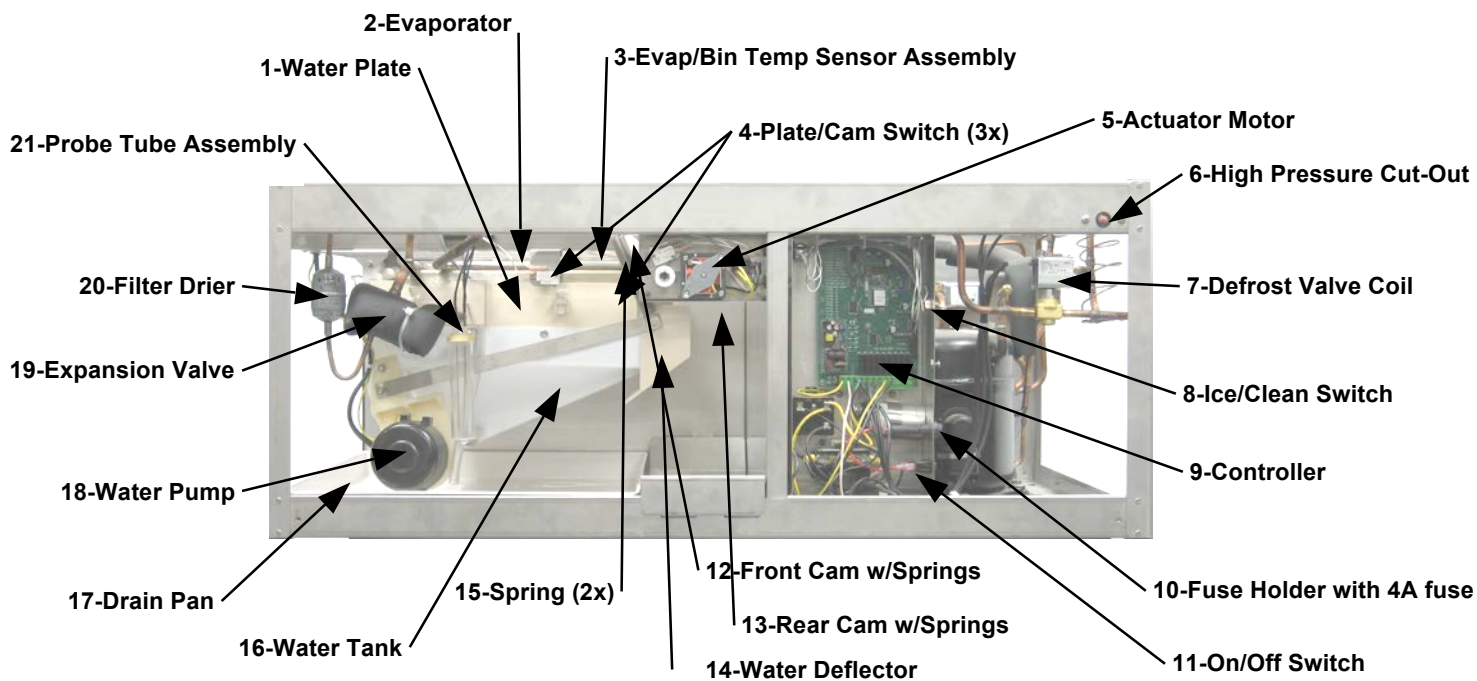

No.	Part Description	Model #	Part No.	No.	Part Description	Model #	Part No.
1	Water Plate "C"	GB56x	<a href="#">GBR00200</a>	9	Controller ( PCB 1.8 )	All	<a href="#">102145901</a>
	Water Plate "HK"	GB56x	<a href="#">GBR00270</a>	10	Fuse Holder with 4A Fuse FUSE ONLY	All	<a href="#">102144901</a> <a href="#">102136301</a>
2	Evaporator-"C"	GB56x	<a href="#">102144501</a>	11	On/Off Switch	All	<a href="#">102138601</a>
	Evaporator-"k"	GB56x	<a href="#">102147201</a>	12	Front Cam w/Springs	All	<a href="#">GBR00969</a>
	Evaporator-"HK"	GB56x	<a href="#">102144601</a>	13	Rear Cam w/Springs	All	<a href="#">GBR00949</a>
	Evap./Bin Temp Sensor-	GB56x	<a href="#">102143901</a>	14	Water Deflector	GB561x	<a href="#">GBR00202</a>
3	Evap. Probe 1.8	GB56x	<a href="#">102145701</a>	15	Spring (2 per PK )	All	<a href="#">GBR00909</a>
	Bin Probe 1.8	GB56x	<a href="#">102145801</a>	16	Water Tank	GB56x	<a href="#">102143301</a>
4	Cam Switch (2)	All	<a href="#">102138001</a>	17	Drain Pan	GB56x	<a href="#">102137801</a>
	Magnetic Plate Switch	All	<a href="#">102147701</a>				
5	Actuator Motor	GB561x	<a href="#">102123801</a>	18	Water Pump All GT3,GT5,GB	ALL IM	<a href="#">102146305</a>
	Actuator Motor	GB564x	<a href="#">102123802</a>		Power Supply	GB564	<a href="#">102146303</a>
6	High Pressure Cut-Out	All	<a href="#">102105501</a>	19	Expansion Valve	GB56x	<a href="#">GBR02359</a>
7	Defrost Valve Coil	GB561x	<a href="#">102101101</a>	20	Filter Drier	All	<a href="#">GBR02750</a>
	Defrost Valve Coil	GB564x	<a href="#">102101201</a>	21	Water Level Assembly Float	GB56x	<a href="#">102146201</a>
8	Ice/Clean Switch	All	<a href="#">102138501</a>				

## GB56x-Air Cooled

**GB561** RUN CAP – 102119704 START CAP – 102119508 START RELAY - 102104709

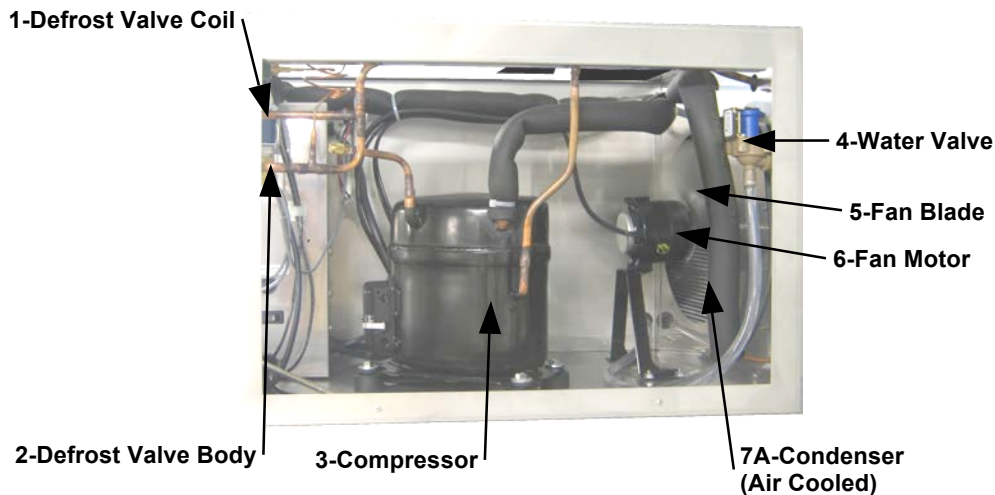

## GB56x-Liquid Cooled

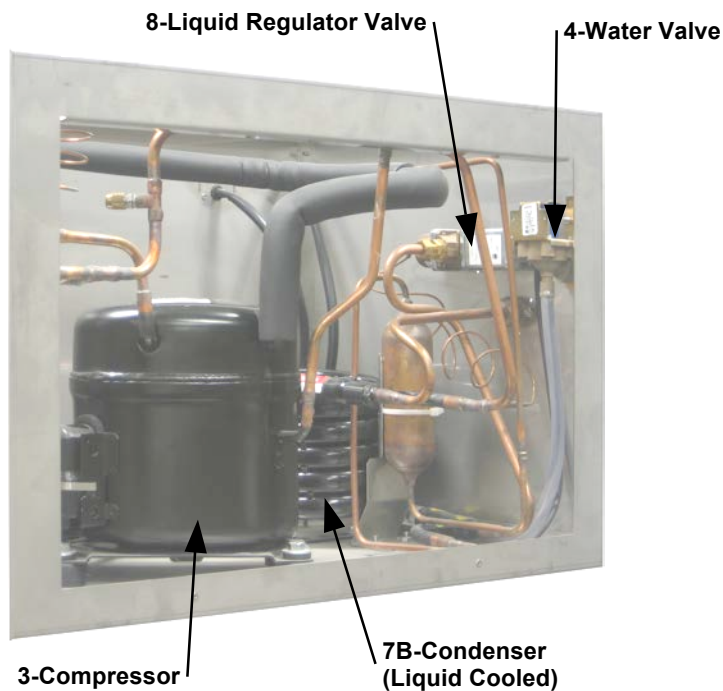

No.	Description	Model(s)	Part No.
1	Defrost Valve Coil	GB561	102101101
	Defrost Valve Coil	GB564	102101201
2	Defrost Valve Body	GB56x	102101001
3	Compressor	GB561	102119128
	Compressor	GB564	102119131
4	Water Valve S/N Before 607945	GB561	102138301
	Water Valve S/N After 607945	GB561	102141201
	Water Valve S/N Before 607945	GB564	102138401
	Water Valve S/N After 607945	GB564	102141101
5	Fan Blade	GB56x	102101602
6	Fan Motor	GB561	102139201
	Fan Motor	GB564	102139301
7A	Condenser-Air Cooled	GB56x	102101802
7B	Condenser-Liquid Cooled	GB56x	102102101
8	Liquid Regulator Valve	All	GAR00701D

**GB564**

RUN CAP – 102104401 START CAP – 102119502 START RELAY – 102104706

## GB1064X Parts

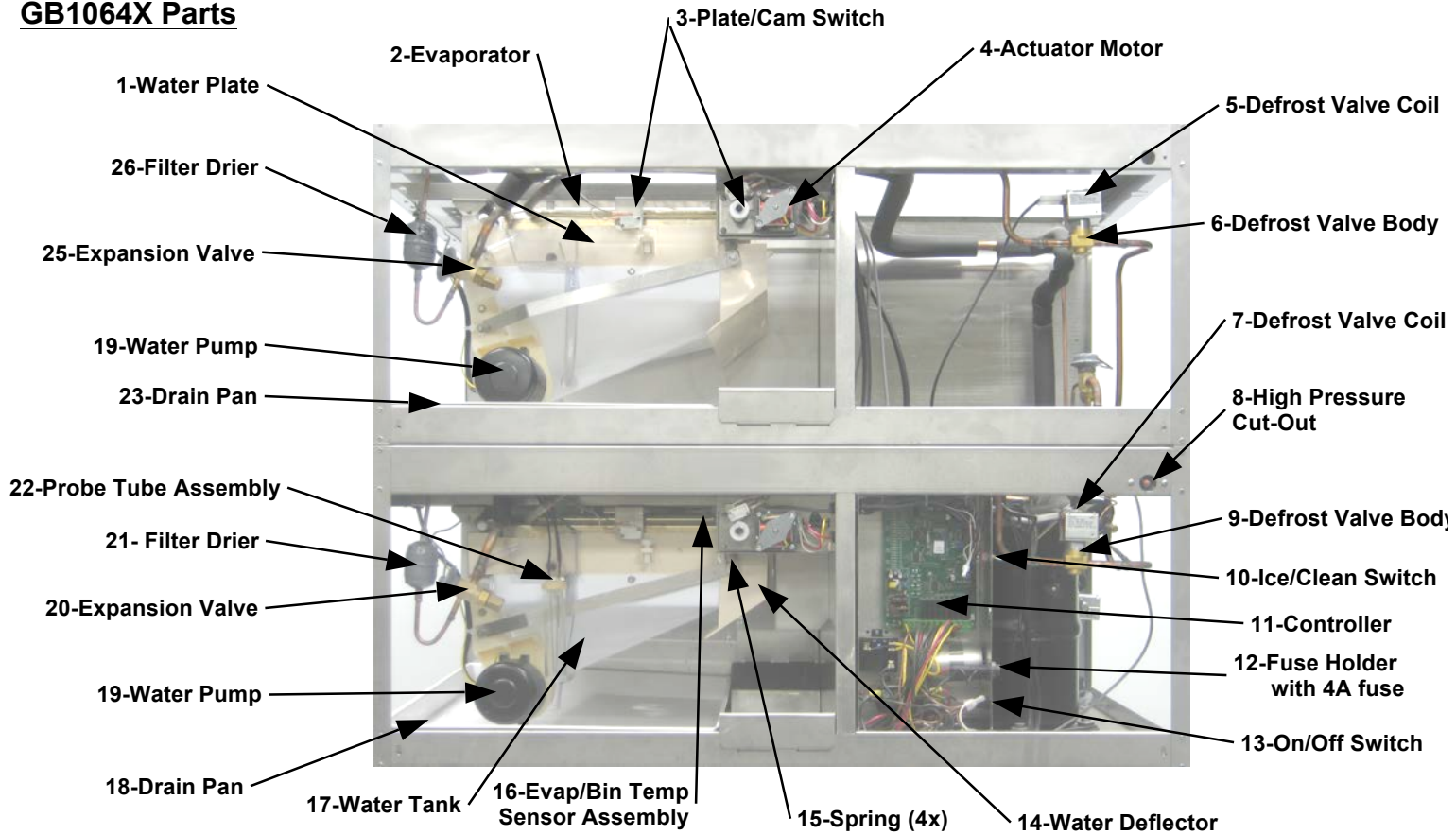

No.	Part Description	Model #	Part No.	No.	Part Description	Model #	Part No.
1	Water Plate "C"	GB106x	<a href="#">GBR00200</a>	12	Fuse Holder with 4A Fuse FUUSE ONLY	All	<a href="#">102144901</a> <a href="#">102136301</a>
	Water Plate "HK"	GB106x	<a href="#">GBR00270</a>		13	On/Off Switch	All
2	Evaporator-"C"	GB106x	<a href="#">102144501</a>	14	Water Deflector	GB106x	<a href="#">GBR00202</a>
	Evaporator-"k"	GB1064x	102147201	15	Spring (2 PER PK )4x	All	<a href="#">GBR00909</a>
	Evaporator-"HK"	GB106xHK	<a href="#">102144601</a>	16	Evap./Bin Sensor-	GB106x	<a href="#">102143901</a>
3	Cam Switch (4)	All	<a href="#">102138001</a>		Evap. Probe 1.8	GB1064x	<a href="#">102145701</a>
	Magnetic Plate Switch	All	<a href="#">102147701</a>	17	Bin Probe 1.8	GB1064x	<a href="#">102145801</a>
4	Actuator Motor	GB1064	<a href="#">102123802</a>		Water Tank	GB106x	102143301
5	Defrost Valve Coil	GB1064	<a href="#">102101201</a>	18	Drain Pan	GB106x	102137801
6	Defrost Valve Body	GB106xA/L	<a href="#">102101001</a>	19	Water Pump All GT3,GT5,GB	ALL IM	<a href="#">102146305</a>
	Defrost Valve Body	GB106xR	<a href="#">102100801</a>		Power Supply	GB1064	<a href="#">102146304</a>
7				20			
8	High Pressure Cut-Out	All	<a href="#">102105501</a>	21	Filter Drier	All	<a href="#">GBR02750</a>
9	Defrost Valve Body	GB106xA/L	<a href="#">102101001</a>	22	Water Level Assembly Float	GB106x	<a href="#">102146201</a>
	Defrost Valve Body	GB106xR	<a href="#">102100801</a>	23	Drain Pan	GB106x	102137801
10	Ice/Clean Switch	All	102138501				
11	Controller	All	<a href="#">102145901</a>	25	Expansion Valve	GB106x	GBR02359
				26	Filter Drier	All	<a href="#">GBR02750</a>

**GB1064R Side**

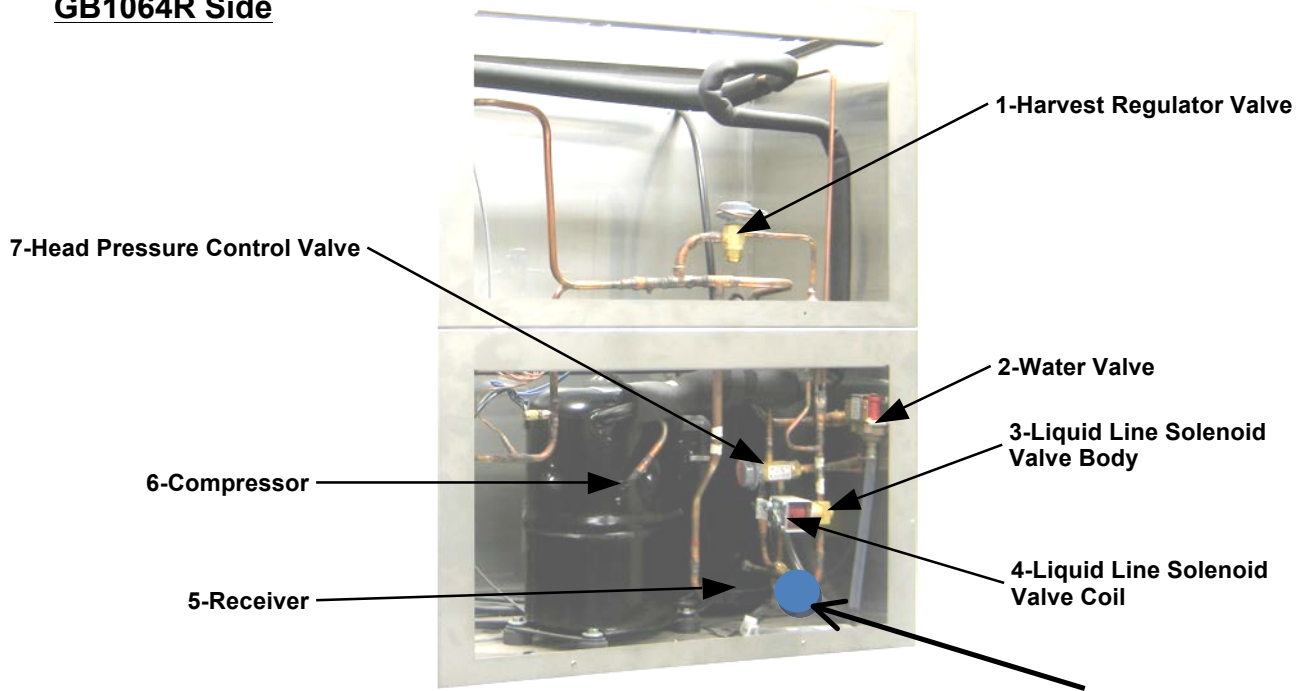

No.	Description	Model(s)	Part No.
1	Harvest Regulator Valve	GB106xR	102122001
2	Water Valve – S/N Before 607945	GB1064	102139101
	Water Valve – S/N After 607945	GB1064	102141301
3	Liquid Line Solenoid Valve Body	GB106xR	102101001
4	Liquid Line Solenoid Valve Coil	GB106xR	102101201
5	Receiver	GB106xR	102102301
6	Compressor	GB1064	102119126
7	Head Pressure Control Valve	GB106xR	GBR02351
8	Drier ( Add on 04/12/13 )	GB1064R	102107101

**RUNCAP** – 102119702

**START CAP** – 102119509

**START RELAY** - 102104713

8- Drier

## GB1064A Side

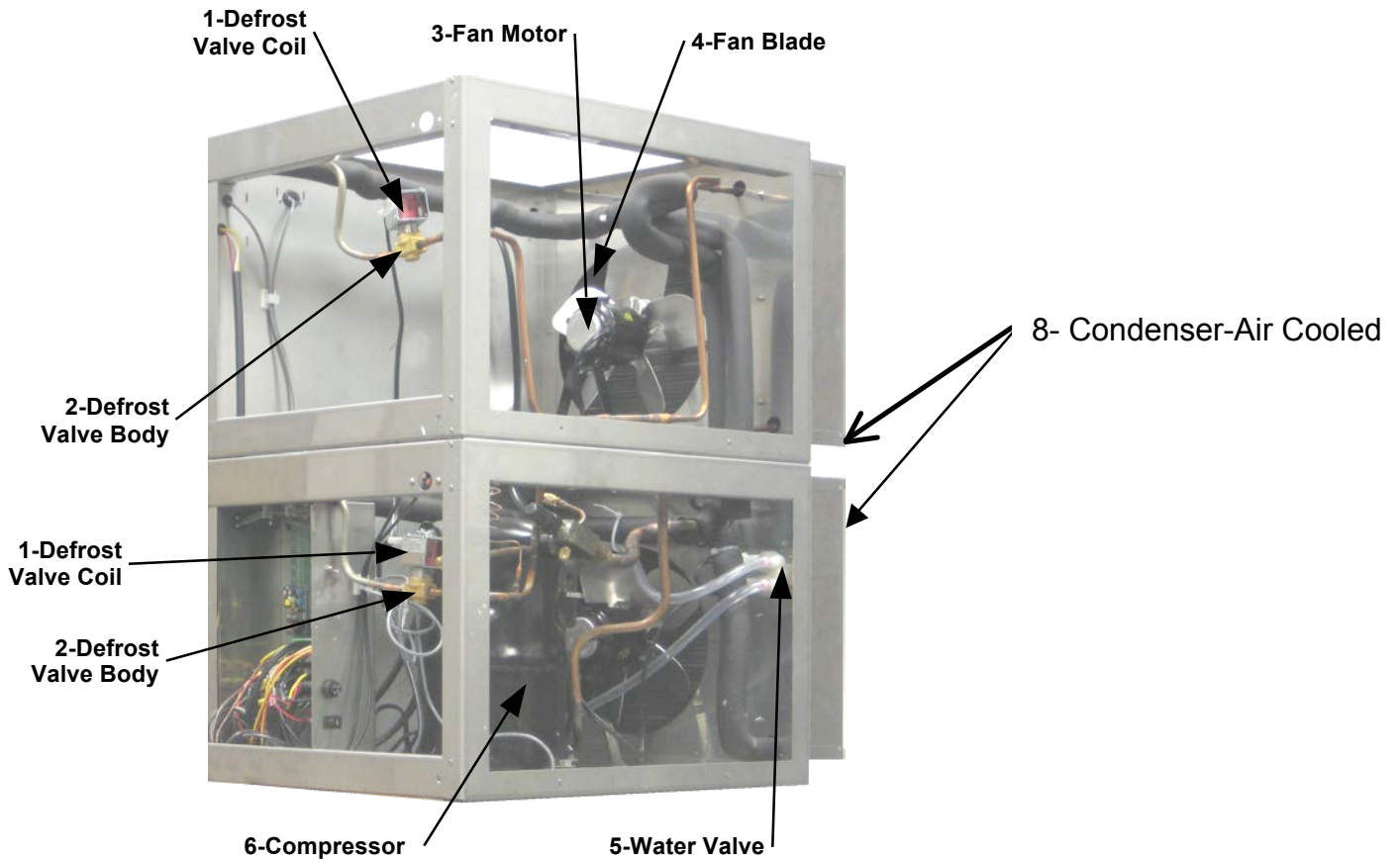

## GB1064L Side

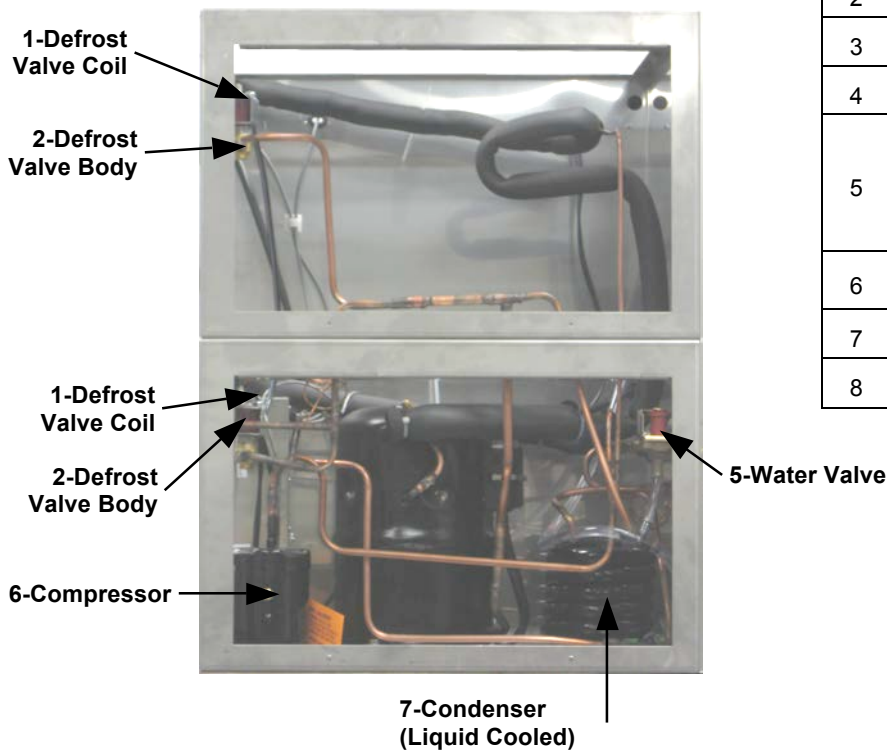

No.	Description	Model(s)	Part No.
1	Defrost Valve Coil	GB1064A	<a href="#">102101201</a>
	Defrost Valve Coil	GB1064L	<a href="#">102101101</a>
2	Defrost Valve Body	GB1064	<a href="#">102101001</a>
3	Fan Motor	GB1064A	102139301
4	Fan Blade	GB1064A	<a href="#">102101602</a>
5	Water Valve – S/N Before 607945	GB1064	<a href="#">102139101</a>
	Water Valve – S/N After 607945	GB1064	<a href="#">102141301</a>
6	Compressor	GB1064	102119126
7	Condenser-Liquid Cooled	GB1064L	<a href="#">102102101</a>
8	Condenser-Air Cooled	GB1064A	<a href="#">102101802</a>

## PARTS LIST

Description	Model(s)	Part Number
Actuator Motor	GT361	102140901
Actuator Motor	GT561, GB561	102123801
Actuator Motor	GT364, GT564, GB564, GB1064	102123802
Actuator Motor Box Cover	GT36x	102143401
Actuator Motor Box Cover	GT56x, GB56x, GB106x	102137201
Actuator Motor Capacitor	GT361, GT561, GB561	102124101
Actuator Motor Capacitor	GT364, GT564, GB564, GB1064	102124102
Cam (Front)	All	GBR00969
Cam (Rear)	All	GBR00949
Cam Pin	All	102121001
Cam Shaft	GT36x	102141801
Cam Shaft	GT56x, GB56x, GB106x	GBR00942
Cam Shaft Bracket	All	GBR00937
Cam Shaft Shim Set	All	GBR00580
Compressor	GT361	102140701
Compressor	GT364	102141701
Compressor	GT561, GB561	102119128
Compressor	GT564, GB564	102119131
Compressor	GB1064	102119126
Condenser-Air Cooled	GT36xA	102141901
Condenser-Air Cooled	GT56xA	102101803
Condenser-Air Cooled	GB56xA, GB1064A	102101802
Condenser-Liquid Cooled	GT36XI, GT56xL, GB56xL, GB106xL	102102101
Contacto-Single Pole 120V Coil	GT361, GT561, GB561	102103501
Contacto-Single Pole 240V Coil	GT364, GT564, GB564, GB1064	102103601
Control Box Cover	GT36x	102142501
Control Box Cover	GT56x	102142601
Control Box Cover	GB56x, GB106x	102137301
<b>Controller 1.8</b>	<b>All</b>	<b>102145901</b>
Defrost Valve Body	GT56x, GB56x, GB106xA/L	102101001
Defrost Valve Body	GT36x, GB106xR	102100801
Defrost Valve Coil	GT361, GT561, GB561	102101101
Defrost Valve Coil	GT364, GT564, GB564, GB1064	102101201
Drain Pan	GT36x	102142201
Drain Pan	GT56x, GB56x, GB106x	102137801
Drain Tube	All	102120101
<b>Drier</b>	<b>All</b>	<b>GBR02750</b>
<b>Drier ( GB1064R )ADD ON 04/12/13</b>	<b>GB1064R</b>	<b>102107101</b>
<b>Evap./Bin Temperature Probe Assembly</b>	<b>GT36x, GB56x, GB106x</b>	<b>102143901</b>
<b>Evap. Probe 1.8</b>	<b>GT56x, GB56x, GB106x</b>	<b>102145701</b>
<b>Bin Probe 1.8</b>	<b>GT56x, GB56x, GB106x</b>	<b>102145801</b>
<b>Evaporator "C"</b>	<b>GT36x</b>	<b>102142101</b>
<b>Evaporator "HK"</b>	<b>GT36x</b>	<b>102142001</b>
<b>Evaporator "C"</b>	<b>GT56x, GB56x, GB106x</b>	<b>102144501</b>
<b>Evaporator "K"</b>	<b>GT56x, GB56x, GB106x</b>	<b>102145701</b>

<b>Description</b>	<b>Model(s)</b>	<b>Part Number</b>
Evaporator "HK"	GT56x, GB56x, GB106x	102144601
Evaporator Shim Set	All	GBR00111
Evaporator Spacer Set	" C" "HK"	GBR00113
Expansion Valve	GT36x	102118802
Expansion Valve	GT56x, GB56x, GB106x	GBR02359
Fan Blade	GT36x, GT56x, GB56x, GB106x	102101602
Fan Motor	GT361, GT561, GB561	102139201
Fan Motor	GT364, GT564, GB564, GB1064	102139301
Fan Motor Support	All	102121404
Front Panel	GT36x	102143701
Front Panel	GT56x	102143801
Front Panel	GB56x	102137901
Front Panel	GB106x	102144101
Fuse Holder With Fuse 4amp	All FUUSE ONLY	102144901 102136301
Harvest Regulator Valve	GB106xR	102122001
Head Pressure Control Valve	GB106xR	GBR02351
High Pressure Cut-Out (Manual Reset)	All	102105501
Hose Kit	All	GBR02087
Ice Deflector Kit	GT36x	102143101
Ice Deflector Kit	GT56x	102143201
Ice Deflector Kit	GB56x, GB106x Lower	102137601
Ice Deflector Kit	GB106x Upper	102139701
Ice-Clean Switch	All	102138501
Left Side Panel	GT36x	102142701
Left Side Panel	GT56x	102142801
Left Side Panel	GB56x	102137101
Left Side Panel	GB106x	102139401
Liquid-Line Solenoid Valve Body	GB106x	102101001
Liquid-Line Solenoid Valve Coil	GB106x	102101201
Liquid Regulator Valve	All	GAR00701D
On-Off Switch	All	102138601
Cam Switch	All	102138001
Magnetic Plate Switch-Kit	All	102147701
Water Level Assembly ( FLOAT )	GT36x, GB56x, GB106x	102146201
Pump-Down Control	GB106xR	102105202
Receiver	GB106xR	102102302
Relay Box Assembly	GT361	102142401
Right Side Panel	GT36x, GB56x	102137501
Right Side Panel	GT56x	102142901
Right Side Panel	GB106x	102139501
Run Capacitor	GT561, GB561	102119704
Run Capacitor	GT564, GB564	102104401
Run Capacitor	GB1064	102119702
Spring ( 2 per PK )	All	GBR00909
Spring Boss	All	GBR00951
Stacking Chute	GB106x	102139601
Start Capacitor	GT561, GB561	102119508
Start Capacitor	GT564, GB564	102119502

Description	Model(s)	Part Number
Evaporator Shim Set	All	GBR00111
Evaporator Spacer Set	All	GBR00113
Start Capacitor	GB1064	102119509
Start Relay	GT561, GB561	102104709
Start Relay	GT564, GB564	102104706
Start Relay	GB1064	102104713
Top Panel	GT36x	102143501
Top Panel	GT56x	102143601
Top Panel	GB56x, GB106x	102137401
Water Deflector	GT36x	102141001
Water Deflector	GT56x, GB56x, GB106x	GBR00202
Water Distributor Tube	GT36x	102143001
Water Distributor Tube	GT56x, GB56x, GB106x	GBR00403
Water Plate "C"	GT36x	102141501
Water Plate "C"	GT56x, GB56x, GB106x	GBR00200
Water Plate "HK"	GT36x	102141601
Water Plate "HK"	GT56x, GB56x, GB106x	GBR00270
Water Plate Hinge Set	All	GBR0028206
Water Plate Plug Set	All	GBR00223
Water Pump All GT360,GT560,GB560,GB1060	ALL IM	102146305
Power Supply	GT364,GT564,GB564,	102146303
Power Supply	GB1060	102146304
Water Supply Tube	All	102137001
Water Tank	GT36x	102142301
Water Tank	GT56x,GB56x, GB106xC	102143301
Water Valve (Up to S/N 607944)	GT361, GT561, GB561	102138301
Water Valve (Up to S/N 607944)	GT364, GT564, GB564, GB1064	102138401
Water Valve (Up to S/N 607944)	GB1064	102139101
Water Valve (Starting at S/N 607945)	GT361, GT561, GB561	102141201
Water Valve (Starting at S/N 607945)	GT364, GT564, GB564	102141101
Water Valve (Starting at S/N 607945)	GB1064	102141301



## STACKING INSTRUCTIONS

### Caution:

- Knowledge of proper installation and service procedures is essential to the safe operation and maintenance of KOLD-DRAFT equipment. Refer all installation and service work to qualified technicians.
- Always disconnect the power supply before servicing the equipment or when the equipment will not be used for a period of time. Some circuits remain energized when the ice machine is switched off.
- Never operate equipment that has been damaged or does not have all the protective covers in place.
- Never operate equipment that has been altered from the original KOLD-DRAFT specifications.
- Special attention should be given to potential hazard labeling on the equipment and the signal words and symbols that are used throughout this manual.
- Instruct all personnel in the proper use of the equipment.
- Clean up any spillage immediately.
- Failure to comply with all KOLD-DRAFT installation guidelines may cause personal injury, equipment or property damage and may void the product warranty.

For stacking 2 or more KOLD-DRAFT 6 series energy efficient ice-making machines.

1. Remove the cabinet panels from the upper and lower ice machines.
2. Mount the frame spacers on the top side panel flanges of the lower ice machine frame.
3. Position so the spacer holes are aligned with the holes in the frame.
4. Position the front panel hanger on the top front rail as shown

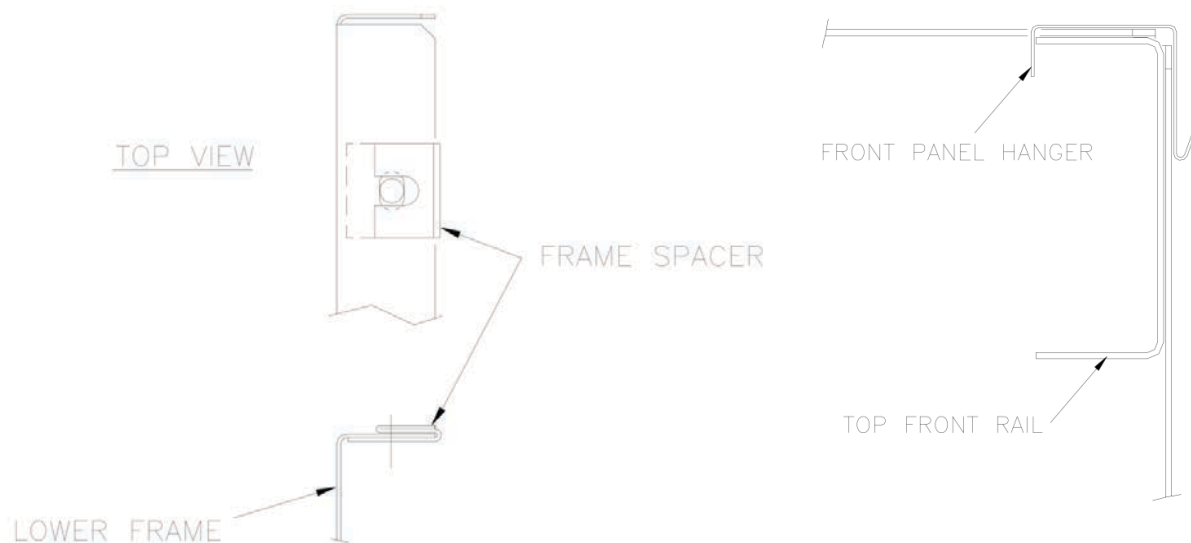

5. Apply the gasket provided to the top of the lower ice machine frame as shown. Place the gasket over the frame spacers to secure them in position.

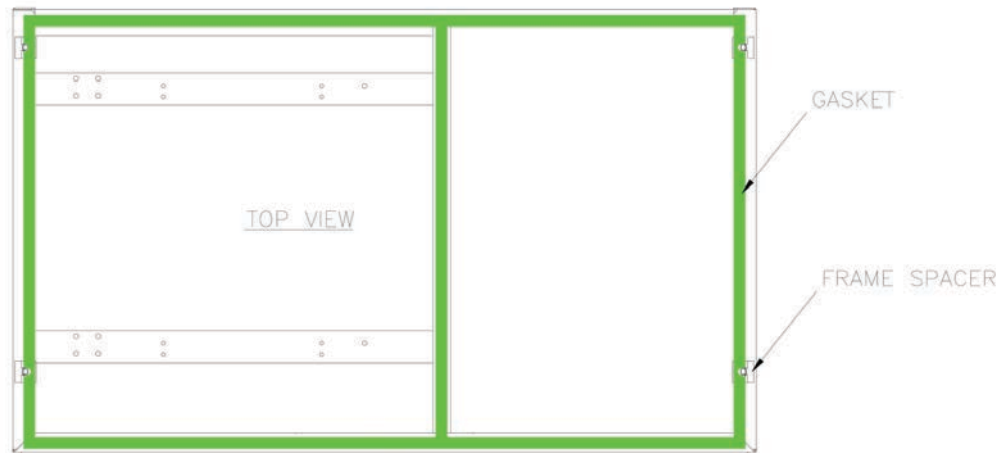

6. Position the stacking chute in the lower machine as shown. Locate on the support channels, against the partition wall.

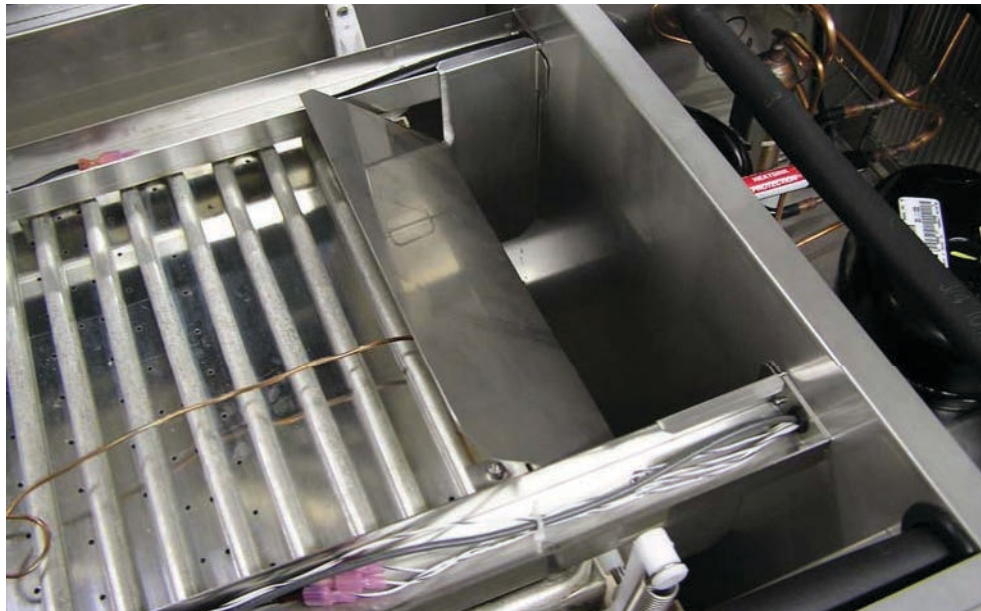

7. Carefully lift the upper machine and place it on top of the lower machine and align the frames. Fasten the frames together using the screws, washers and lock nuts provided

**DANGER:** It is highly recommended that 2 or more people perform this job, if the machine falls it could cause serious injury or death.

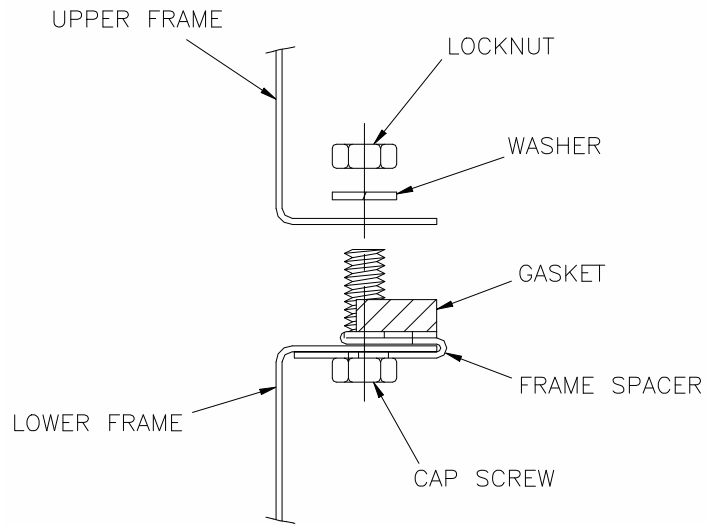

8. Replace the front and back deflectors of the top ice machine with the deflectors provided in the stacking kit. Install the deflectors into the slots in the back wall and front rail. Push down on the deflectors until they engage beside the stacking chute and snap in place.



9. Feed the bin probe from the upper machine, through one of the holes in the upper machine condensing unit pan and position in one of the holes in the lower ice machine condensing unit pan and adjust as required.

# **ICE CUBE CRUSHERS - T27X**

(For KOLD-DRAFT GB series Ice Makers)

## **Installation, Operation, Technical Service and Replacement Parts**

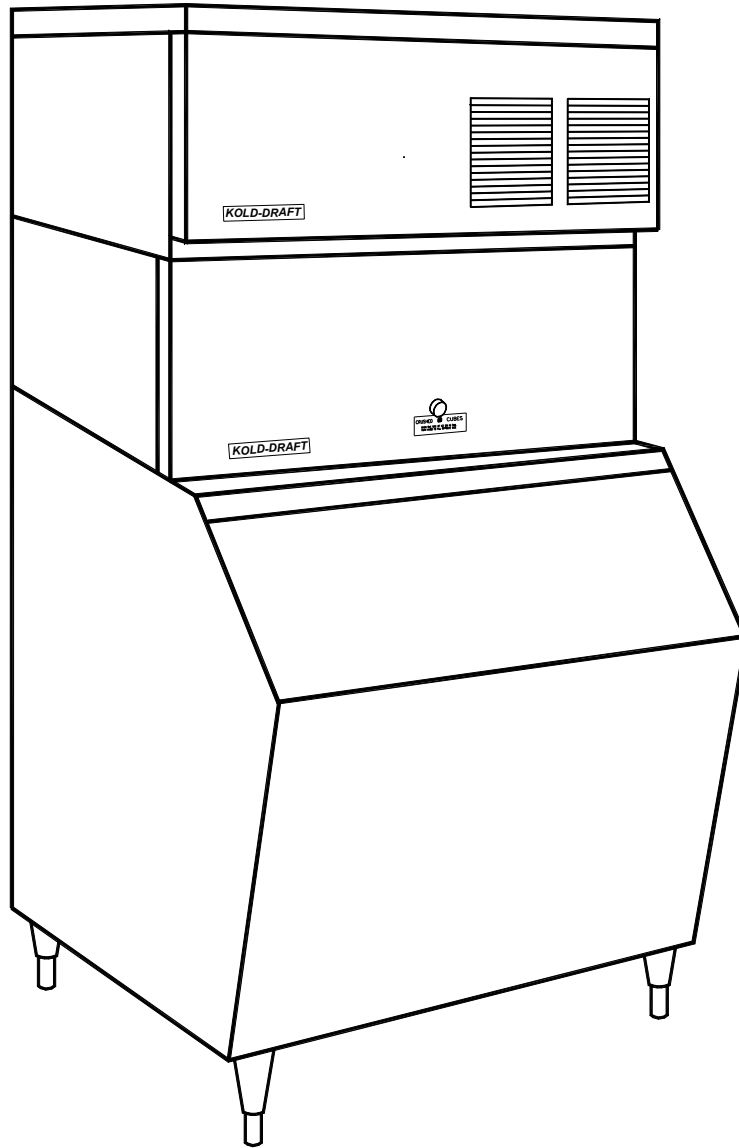

## ICE CRUSHER-SAFETY INFORMATION

Special attention should be given to potential hazard labeling on the equipment and the signal words and symbols that are used throughout this manual. They may also be used to alert against unsafe practices

**Note:** Note is used to notify personnel of installation, operation or maintenance information which is important, but not a cause of personal injury or property damage.

**Warning:** Indicates a potentially hazardous situation that may result in minor or moderate injury. The situation may also cause minor damage to the machine

**Caution:** Indicates a potentially hazardous situation that could cause serious injury or death. The situation may also critically damage the machine

**DANGER:** Indicates a potentially hazardous situation that could cause serious injury or death. The situation may also critically damage the machine

Check for freight damage before proceeding, even though damage to the carton may not have been evident, check for hidden damage and contact freight carrier immediately if necessary to file a claim.

This equipment must be installed in compliance with the applicable federal, state/province and/or local plumbing, electrical and health/sanitation codes and requirements.

**Caution:**

- Risk of personal injury, property damage, equipment failure or fire.
- Refer all maintenance to qualified personnel.
- Risk of personal injury, property damage, equipment failure or fire.
- Never operate this equipment with covers, panels or other parts removed or not properly secured.
- Warn all users to clean up spillage immediately, keep storage bin doors closed, and report any apparent leakage or unusual sounds to maintenance personnel.
- Proper installation must include KOLD-DRAFT® GB Series Ice maker mounted above Crusher.

## ICE CRUSHER INSTALLATION

### Notes:

- Check for freight damage before proceeding with the equipment installation. Be sure to inspect the equipment carefully for any damage that may not have been evident on the outside of the carton. Contact the freight carrier immediately to report any damage and file a claim.
- To ensure optimal efficiency and productivity these installation instructions should be followed accurately.
- All machines have been tested and adjusted for correct performance at the factory.
- This equipment must be installed in compliance with the applicable federal, state/province, and/or local plumbing, electrical, and health/sanitation codes and requirements.

### *Warning:*

- Do not operate equipment that has been damaged.
- Refer all maintenance to qualified personnel.
- Instruct all personnel in the proper use of the equipment.
- Clean up any liquid spills immediately.
- Always install equipment on a stable and level surface.
- All models are intended for indoor use only. Do not install the equipment in unprotected outdoor areas.
- Always securely attach individual machines together.
- Do not install the equipment in wet areas.
- Do not locate the equipment near any heat source, in direct sunlight, in high ambient areas, or without proper clearance for ventilation. Placing equipment in these locations will result in reduced capacities, high system pressures and may cause equipment failure.

### **Pre-Install Checklist**

- All KOLD-DRAFT models are intended to be installed with a permanent connection to the field electrical supply. Drop cord connections are not to be used with this equipment. Always be sure the power supply is the same as the ice machine's electrical specification which is listed on the serial number tag on the front of the top frame cross member
- Each ice crusher must be connected to the grid through its own dedicated fuse or HACR type circuit breaker.
- Each ice crusher must be connected to a separate protected circuit with no other loads.
- Fused disconnects, installed adjacent to each ice maker, are recommended and may be required by local codes.
- Electrical service must fall within the voltage tolerances listed below

Nominal (V)	No-Load Maximum	Full-Load Minimum
115 (1 Series)	126	104
208/230 (4 Series)	250	210

- Breaker or fuse rating must be no greater than the maximum rating as specified on the rating label attached to the back of the machine.
- The minimum circuit ampacity listed on the back of the machine does not indicate a typical running current value. Use the minimum ampacity value for sizing branch circuit conductors up to 8 meters (26 feet) in length. For a conductor length over 8 meters, increase the wire gauge as required by code.

**DANGER: Failure to comply with these regulations may cause serious injury or death and cause damage to the machine and its surroundings.**

## Assembly/Installation

1. Position the ice storage bin maintaining the minimum clearances specified in the ice maker instructions.
2. Level the bin with adjusters on its legs, or by shimming if the bin is to be sealed to the floor. If there are gaps between the bin and the floor greater than 1/8 inch, install a cove molding around the bin bottom. Seal the bin (and molding) to the floor with NSF Certified RTV sealant (Dow-Corning RTV 732 or equivalent).
3. Install gasket on top of bin if not already installed. Gasket material must be positioned so that it extends to the outside edge of the perimeter of the ice crusher chassis when the ice crusher is in place. To apply the gasket, peel away the white backing strip and press firmly in place.
4. Place the crusher on a flat surface. If the floor is a rough or marring surface place a large rag or rubber mat on the floor to the left of the crusher and stand the crusher on its left side.
5. Position the bottom guard so that the right side flange is hung over the ice breaker bar.

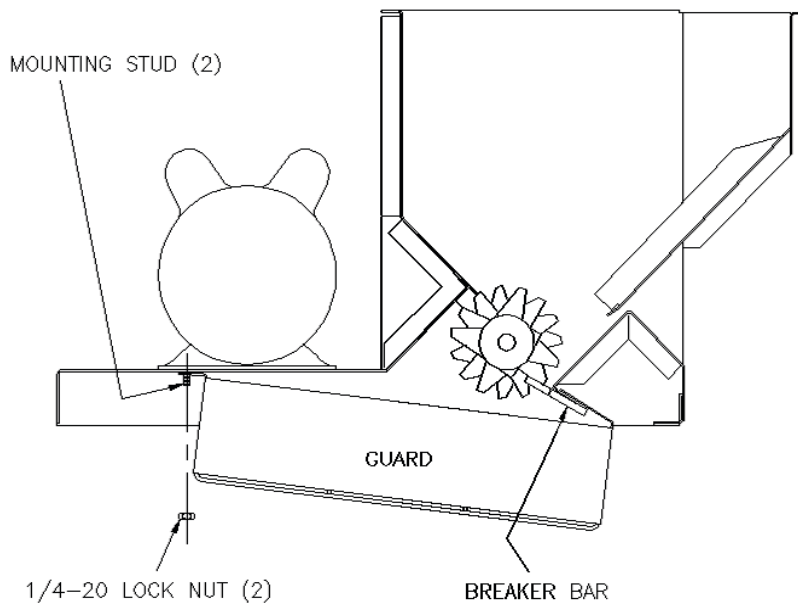

6. Install the left side flange over the mounting studs and secure in place with the supplied 1/4-20 lock nuts.

**Note:** Use care when positioning the ice crusher on the bin so that the guard is not damaged. Be sure to check for internal bin components such as deflectors, dividers etc., which may interfere with the guard during installation.

7. Carefully lift the crusher and place onto the bin. Remove the front cover and note the alignment of the mounting holes in the chassis if mounting means are provided on the bin. Follow the bin installation instructions for securing the crusher to the bin.

**Note:** The plastic selector knob must be removed before the front cover can be removed on older machines.

8. Insert the straight thermostat holder tube into the rubber grommet located directly behind the crusher motor. Route the crushed ice thermostat capillary tube through the straight thermostat tube holder. Ensure that the capillary tube is slightly protruding from the bottom of the tube holder.

Place the cube ice thermostat capillary tube into the bent thermostat tube holder. Ensure that the capillary tube is slightly protruding from the bottom of the tube holder. Mount the tube holder as shown using the supplied hardware. Tighten the clamp screws. The picture below is a view of the right side of the crusher assembly from within the crusher frame. This portion will be above the un-crushed cube side of the bin.

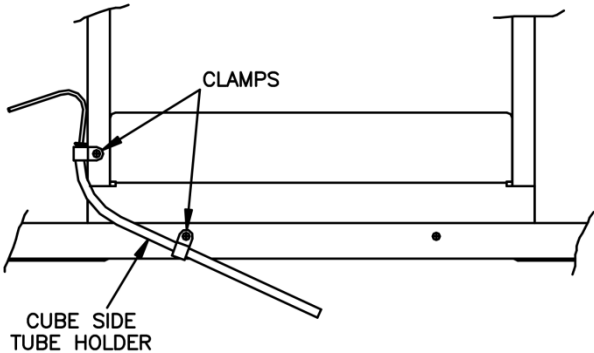

- 9. Install gasket on top of crusher.
- 10. Remove the ice maker cabinet panels, lift and position ice maker on top of crusher with gasket and align the mounting holes. Install cap screws, lock washers and nuts.

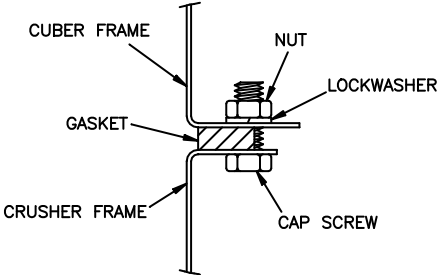

- 11. Mount the ice maker safety switch as shown. If not provided, locate and drill two 3/16 inch dia. holes in the ice maker lower front rail. Mount the safety switch support with the #8-32 screws

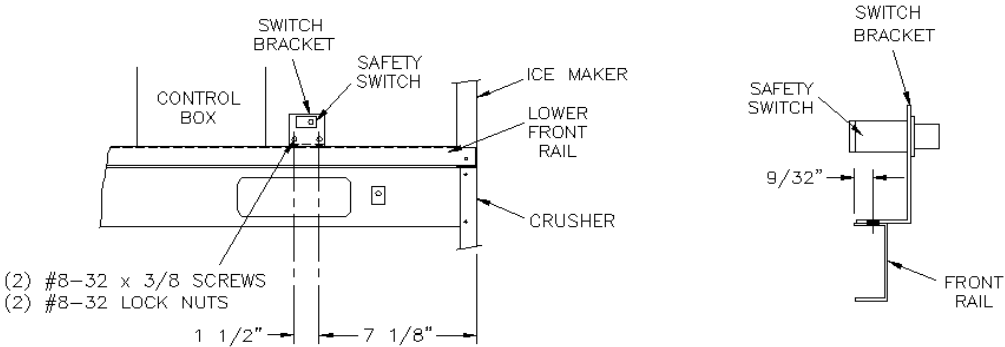

and lock nuts provided.

Notes:

- The crusher is designed to operate in conjunction with one or two KOLD-DRAFT® ice makers. Two motor control relay blocks are provided and a relay coil must be installed for each ice maker used. Each relay coil must have a voltage rating matching the voltage of

the ice maker, regardless of the crusher motor voltage. T271 crushers are supplied with 115V relays. T274 crushers are supplied with 208-230V relays. The relay coils are installed through the opening in the control box. A third relay is provided for controlling one or two ice makers with the same set of bin thermostats. This relay coil voltage rating is matched to the crusher motor voltage and is provided with the crusher.

- A dual safety switch system is employed in the crusher design to break the circuit to the motor. If either the front panel of the crusher or the front panel of the bottom ice maker is removed, a switch will open the motor circuit. The crusher safety switch is mounted in the crusher control box.

12. Install a grommet in the pre-cut hole in the floor of the ice maker's compressor compartment directly behind the controller box.

13. Push the safety switch wire assembly (wires with insulated 90 ° flag terminals) and the motor control wire assembly (wires with piggyback terminals) through the grommet into the ice maker

14. Connect the safety switch wires from the crusher to the "Common" and "Normally Open" terminals of the ice maker safety switch (the two outer terminals). (See Wiring Diagram)

**Note:** There are two motor control wire assemblies of different lengths. When using a stacked machine the shorter wire assembly gets connected to the lower ice maker and the longer wire gets connected to the upper ice maker. If the ice maker is not a stacked unit the longer wire is unused

**Warning:** The safety switches do not de-energize all circuits in the crusher or circuits in the ice maker. Before cleaning or servicing this equipment disconnect all power supplies.

15. Disconnect the white plug assembly from the ice maker hot gas valve. (If installing a GB1064 ice maker there are two hot gas valves. Use the lower of the two to connect the crusher).

16. Connect piggyback terminals of the motor control wire assembly to the tabs of the hot gas valve on the ice maker.

17. Reconnect the white plug assembly to the piggyback terminals of the motor control wire assembly as shown below.

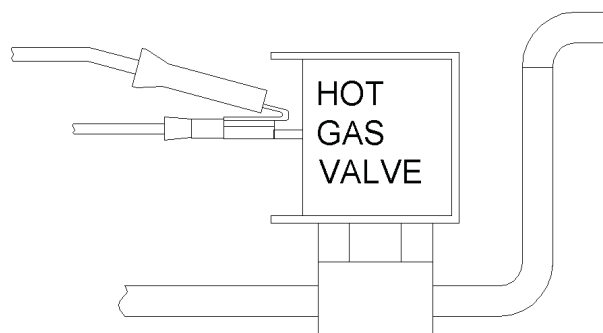

18. Locate the bin thermostat of the ice machine and cut the probe off of the end of the cable

19. Route the cable through one of the small holes in the bottom of the ice machine and into the back of the crusher control box

20. Pull the cable out through the front of the crusher control box and cut off the cable to a manageable length.
21. Strip the outer cable jacket back about 3". Then strip the red and black wires back about ¼".
22. Connect the stripped wires to the left relay as shown.

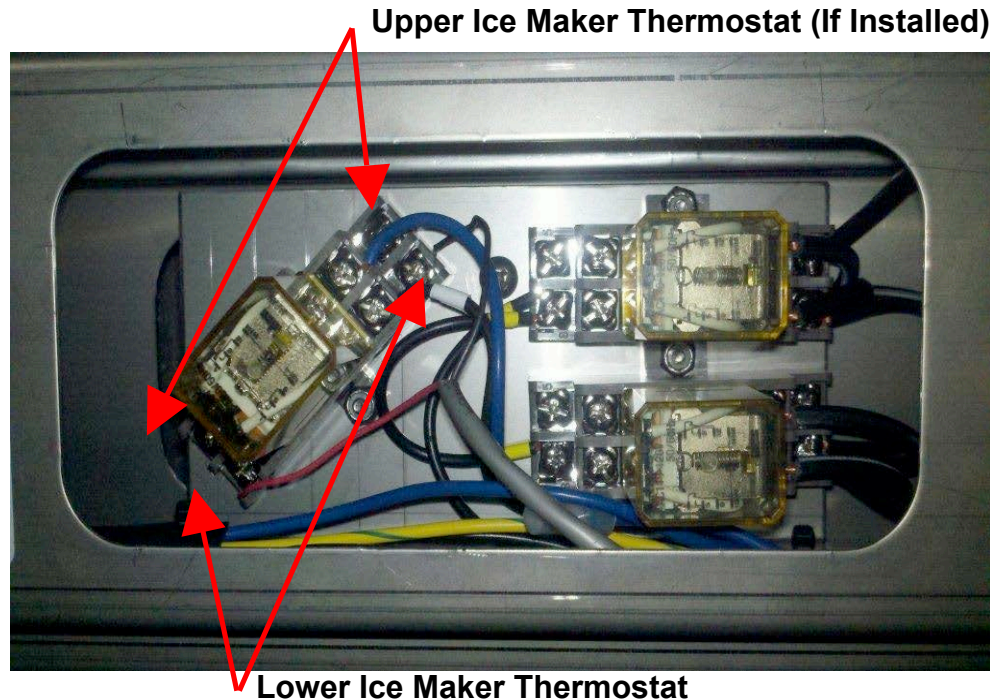

23. Turn off the breaker or disconnect the fuse that will service the machine.
  24. Make all electrical connections to the electrical service in a manner that complies with local code
- Note:
- If two separate ice making machines (for example two GB1064 models stacked) are installed the bin thermostats of both ice makers will need to be connected to the crusher.
  - Ensure that the thermostat cable is not routed through the ice chute. Do not run the cable through the same hole that the safety switch wire assembly and the motor control wire assembly are run through.

### **Initial Start-Up**

1. Ensure all electrical connections were made properly and turn on the electrical service.  
Note: There is no on-switch, the machine will run when the ice-maker tells it to.
2. Adjust the bin thermostat to turn off the ice maker before the ice level is above the guard screen.
3. Adjust the thermostats to shut off the ice maker approximately 1 minute after the ice contacts the capillary tubes.

Note:

- If ice is allowed to collect above the screen it will not clear when the ice below is removed. This condition will cause ice to pile up in the chute of the crusher and ultimately, damage the ice maker

- The use of the bottom guard will reduce the effective volume of the bin

### **ICE CRUSHER OPERATION**

With the crusher knob in the crushed position, ice falling from the ice maker will be directed by the selector plate through the crusher mechanism and deposited into the left side of the bin.

The crusher motor is powered through a relay which is energized by the hot gas valve circuit of the ice maker. The selector knob must be in the crushed position to close a switch and complete the circuit to the motor. Additionally, the front panel safety switches must be depressed (covers on) for motor operation.

With the crusher knob in the "CUBE" position, ice falling from the ice maker will bypass the crusher mechanism and be dumped into the right side of the bin. The crusher motor will not be energized.

## **ICE CRUSHER CLEANING PROCEDURE**

### **DANGER:**

- Disconnect or turn off all ice machine and crusher fuses or breakers before cleaning either machine.
- Do not use ammonia solutions or strong detergents in cleaning the crusher.
- Never use appliance polishes, finish preservatives or cleaners in areas that could contact ice.

### *Warning:*

- Always clean the ice maker first, following the ice maker cleaning instructions.
- Remove all ice from the bin before starting the cleaning procedure.
- Clean and sanitize storage bin last.

1. Remove ice maker panels, ice chute, deflectors, drain pan, crusher front panel and belt guard.
2. Wash interior with a solution of 2 tablespoons of baking soda per quart of clean warm water, 140°F (60°C) max. The crusher ice hopper can be accessed from the front and left side of the ice maker. Use a long handled brush to clean inside the hopper, as crusher teeth are sharp and can cause injury.
3. The bottom area of the crusher ice hopper can be accessed from inside the ice bin. Use a long handled brush.
4. Wipe down internal cabinet walls with a cloth soaked in cleaning solution.
5. Rinse with clean tap water.
6. Sanitize all ice contact surfaces with a solution of 1/2 teaspoon 5-1/4% sodium hypochlorite (chlorine bleach) per quart of clean tap water (minimum 100 PPM free chlorine). A spray bottle will facilitate this process.
7. Pour the remaining solution into the crusher chute, slowly, while rotating the cutter wheel by hand turning the pulley.
8. After adjusting and lubricating crusher (See following section), replace all enclosure panels and connect the electrical supply.
9. Exterior surfaces may be cleaned by standard methods suitable to the stainless steel finish.

## **ADJUSTMENT AND LUBRICATION**

1. Oil the crusher motor (if ports are provided) and grease the shaft bearings.  
(Do not over-lubricate)
2. Check the belt and pulleys for excessive wear. Adjust the belt tension to deflect 5/32 inch with two pounds applied to the center of the span.
3. Tighten any loose set screws, machine screws, nuts and electrical connections.

# WIRING DIAGRAM

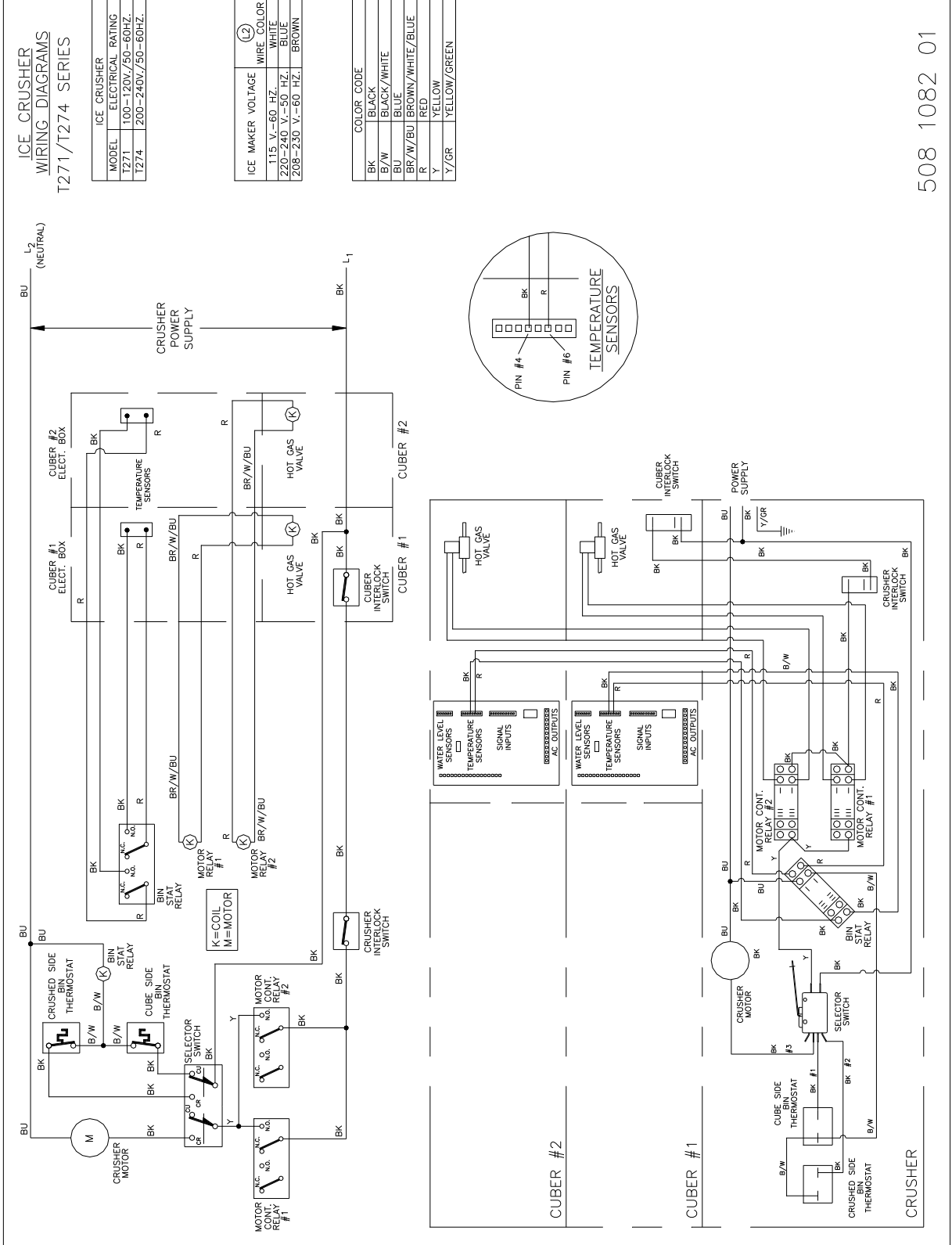

508 1082 01

# PRE-CHARGED REMOTE AIR-COOLED CONDENSER - RC214APV

## Installation, Operation, Technical Service and Replacement Parts

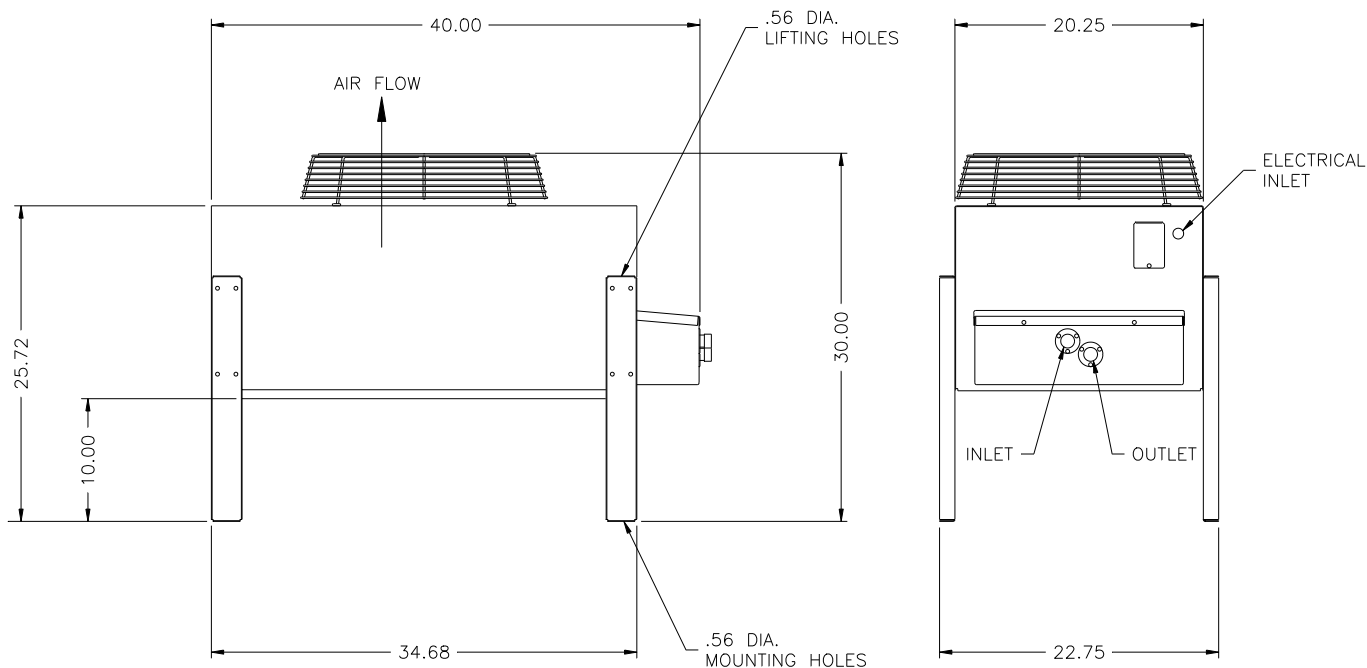

### PARTS FOR CONDENSER

- GBR01890** 1/2" MALE SELF SEAL COUPLING FOR CONDENSER / ICE MAKER
- GBR01889** 3/8" MALE SELF-SEALING COUPLING FOR CONDENSER / ICE MAKER

### PARTS FOR LINE SET

- GBR02218** 1/2" FEMALE SELF SEAL COUPLING FOR LINE SET
- GBR02219** 3/8" FEMALE SELF-SEALING COUPLING FOR LINE SET

### 102140601 FAN MOTOR-RC214APV/RC314APV -230V

Stock code	Quantity per	Uom	Description
<b>513105801</b>	<b>1.0000</b>	<b>PC</b>	<b>RAIN SHIELD-RC214APV CONDENSER</b>
<b>516102901</b>	<b>1.0000</b>	<b>EA</b>	<b>RC FAN MOTOR, US MOTORS 3402 1/10 HP</b>
<b>301182501</b>	<b>1.0000</b>	<b>EA</b>	<b>CONDENSER MOTOR MOUNT CRADLE</b>
<b>301182601</b>	<b>2.0000</b>	<b>EA</b>	<b>CONDENSER MOTOR MOUNT STRAP</b>
<b>503100321</b>	<b>3.0000</b>	<b>EA</b>	<b>SCREW #8-32 X 5/8 PH PAN HD SS</b>
<b>503101901</b>	<b>3.0000</b>	<b>EA</b>	<b>LOCKNUT-8-32 SS W/NYLON INSERT</b>
<b>510126601</b>	<b>1.0000</b>	<b>EA</b>	<b>RC RUN CAPACITOR - 5 MFD +/-6% 370 VAC</b>

## **PRE-CHARGED REMOTE AIR COOLED CONDENSER - INSTALLATION**

### **Note:**

- Check for freight damage before proceeding with the equipment installation. Be sure to inspect the equipment carefully for any damage that may not have been evident on the outside of the carton. Contact the freight carrier immediately to report any damage and file a claim.
- To ensure optimal efficiency and productivity these installation instructions should be followed accurately.
- All machines have been tested and adjusted for correct performance at the factory.
- This equipment must be installed in compliance with the applicable federal, state/province, and/or local plumbing, electrical, and health/sanitation codes and requirements.

### **Warning:**

- Do not operate equipment that has been damaged.
- Refer all maintenance to qualified personnel.
- Instruct all personnel in the proper use of the equipment.
- Clean up any liquid spills immediately.
- Always install equipment on a stable and level surface.
- Never operate this equipment with covers, panels, guards or other parts removed or not properly secured.
- KOLD-DRAFT reserves the right to disallow any warranty claims which result from the use of non KOLD-DRAFT condensers and/or line sets.
- Read the entire manual before installing, operating or servicing the machine.

### **Pre-Install Checklist**

- All KOLD-DRAFT models are intended to be installed with a permanent connection to the field electrical supply. Drop cord connections are not to be used with this equipment. Always be sure the power supply is the same as the ice machine's electrical specification which is listed on the serial number tag on the front of the top frame cross member
- Each ice maker must be connected to the grid through its own dedicated fuse or HACR type circuit breaker.
- Each ice maker must be connected to a separate protected circuit with no other loads.
- Fused disconnects, installed adjacent to each ice maker, are recommended and may be required by local codes.
- Breaker or fuse service must be no greater than the maximum rating as specified on the rating label attached to the back of the machine.
- The minimum circuit ampacity listed on the back of the machine does not indicate a typical running current value. Use the minimum ampacity value for sizing branch circuit conductors up to 8 meters (26 feet) in length. For a conductor length over 8 meters, increase the wire gauge as required by code.
- Remote condenser ambient air temperature: 110°F (43°C) maximum
- Try to keep the compressor warmer than the condenser. In most installations, the ice maker runs enough so that residual motor heat minimizes liquid migration to the crankcase. If the ice maker is in a cool location, or if it will be OFF for extended periods, a crankcase heater should be installed.
- Avoid placing the condenser in the exhaust air stream of other equipment or within a distance equal to the width of the condenser from a wall or another piece of equipment. Stay away from kitchen exhaust fans to prevent grease accumulation on the fins. Use a curb, which extends above the deepest expected pond in the condenser area of the roof.

## **Installation**

1. Unpack the condenser and install the mounting legs.
2. Fasten the condenser to its mounting surface using methods that will satisfy the building codes in your area. The condenser must not be lower than the receiver.
3. The line sets are packed separately, with the quantity and length marked on the carton. Make sure that the lines are correct for your installation.
4. A single circuit condenser installation, which uses one line set, will require a 1-3/4" dia. hole to pass the lines through a ceiling or wall. The lines for a 2 circuit condenser require a 2" dia. hole.
5. Each line set consists of a 3/8" liquid line, and a 1/2" insulated discharge line. Connect the 3/8" line to the lower (liquid) fitting on the condenser, and to the "Refrigerant In" on the ice maker. The 1/2" line connects to the upper (inlet) fitting on the condenser, and the "Refrigerant Out" on the ice maker.
6. Each fitting on the line sets, condenser and ice maker is self-sealing, and should be tightened 1/4 turn more than hand tight. Always use a backup wrench to prevent tubing twist when tightening these fittings.
7. The condenser fan motor requires power supply provisions that comply with all applicable code requirements. The Ice Maker is provided with wire connection pigtails that include an L1 red wire for connection to the fan motor circuit along with L2 and Grounding conductors.
8. The refrigerant lines should be routed inside the building or otherwise mechanically protected wherever possible.

**Caution:** For multiple-circuit installations fan power must be provided separately by a circuit that will not be interrupted so that the fan motor will run continuously.

Remote condenser Ice Maker models from the factory are provided with adequate refrigerant charge to accommodate all acceptable condenser ambient temperatures and up to 50 ft. refrigerant lines. The Ice Maker Nameplate label on the rear of the cabinet indicates the factory charge amount, maximum total charge, and refrigerant type. Ice makers are provided with re-sealable refrigerant line connection couplings.

## **Specifications**

<b>MODEL NUMBER</b>	<b>VOLTAGE</b>	<b>DESCRIPTION</b>	<b>W" x D" x H"</b>	<b>Gross Wt (Lbs)</b>
RC214APV	208-230/60/1 0.7 FLA	1 Circuit - 2 Ton - R/404a Pre-charged Remote Condenser GB564R/GT564R	20-1/8 x 34-3/4 x 30 w/legs & guard	160
RC314APV	208-230/60/1 0.7 FLA	1 Circuit - 2 Ton - R/404a Pre-charged Remote Condenser GB1060R	20-1/8 x 34-3/4 x 30 w/legs & guard	160

**Caution:** Refrigerant charges must be accurately weighed.

## **Minimum Total Charge Required**

### Note:

- The factory charge in dual-evaporator models is 168 oz (10.5 lb) R-404a.
- The maximum total system charge for dual-evaporators is 208 oz (13 lb) R-404a.
- The basic charge for a dual-evaporator model is 3 lb R-404a.

To determine the total charge, add the following to the basic charge below:

1. For each 10 feet of 3/8" O.D. liquid return tubing add 6 oz of R-404a.
2. For each 10 feet of 1/2" O.D. compressor discharge line >70° F add 1/2 oz R-404a.
3. For each 10 feet of 1/2" O.D. compressor discharge line <70° F add 11 oz R-404a (assume that at least 15' will be <70° F if not certain).
4. Use the following amounts of R-404a according to the condenser model and the MINIMUM ambient temperature expected at the condenser:

RC214APV & RC314APV	
+60° F	2.3 lb
+40° F	2.9 lb
+20° F	3.2 lb
0° F	3.3 lb
-20° F	3.5 lb

**EXAMPLE:** Calculate the minimum total system charge for a GB1060R Ice Maker with an RC214APV (single-circuit, 2-ton) condenser and 30 feet of interconnecting tubing with -20° F minimum condenser ambient temperature. The calculation would be as follows: 3 lb (basic charge) + 16.5 oz (15' of 1/2" O.D. discharge line at <70° F) + 0.75 oz (15' of 1/2" O.D. discharge line at >70° F) + 3.5 lb (flooded condenser at -20° F) = 121.25 oz (7.6 lb). The factory charge for GB1060R models is 10.5 lb.

**Caution:**

- Do not exceed the specified maximum total system charge.
- Interconnecting lines over 50' are not recommended.
- Lines must be pitched upward toward the condenser with no "droops" or traps.

**Note:** The compressor will start immediately when power is applied, regardless of the "On/Off" or the "Make Ice/Clean" switch positions, if the low-side pressure is at or above the pump-down controller cut-in setting and the high-pressure cutout is not open. Be sure that the compressor stops when the low-side pressure is between 5 and 15 psig.

## Electrical Information

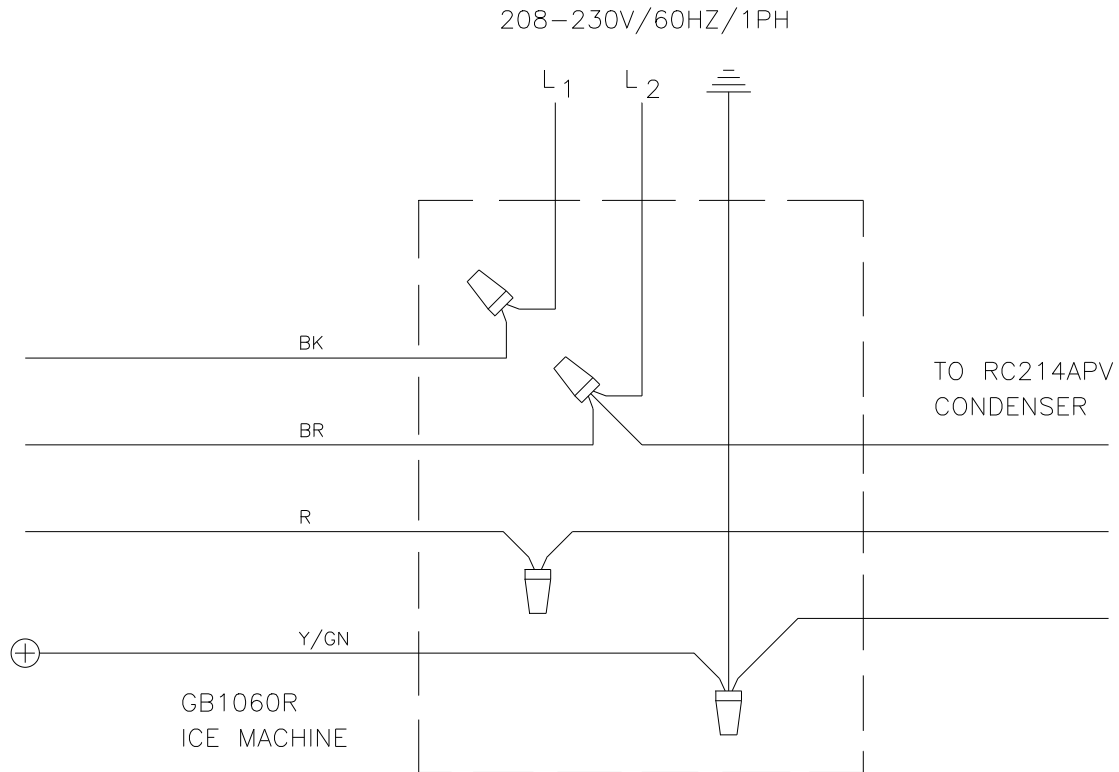

### Removing From Service

When the ice maker is determined to be no longer useable please be sure that it is rendered safe for storage or disposal. All applicable recycling measures should be exercised to avoid injury and harm to the environment.

The manufacturer and/or seller are not responsible for any harm to people, animals, property, and the environment caused by incorrect installation and/or disposal.

-END OF DOCUMENT-

**KOLD-DRAFT®**

# SC200 Series Ice Machine



## Installation & Operation Manual



Intertek



Intertek

### **Kold-Draft International, LLC**

1525 East Lake Road  
Erie, PA 16511-1088 U.S.A.  
Phone: (800) 840-9577  
Fax: (800) 548-9392  
[www.kold-draft.com](http://www.kold-draft.com)

**KOLD-DRAFT INTERNATIONAL, LLC**  
A DIVISION OF THE LEGACY COMPANIES, LLC

Installation & Operation Manual

SC200 Series Ice Machine

Copyright2016 KOLD-DRAFT INTERNATIONAL, LLC

Unauthorized reproduction of this manual is freely permitted for all purposes except for monetary gain.

It is not guaranteed that this service manual is up to date, technically correct, complete, or free from writing problems or that the product is free from minor flaws or that it meets the needs of the customer.

May 2017

## Table of Contents

### Section 1 General Information

Safety Information.....	1
Model Number Key.....	2
Date Code Key.....	2
Serial Number Plate Location.....	2

**Section 2 Installation**

Unpacking .....3  
Carton Contents.....3  
Installation Requirements.....4  
Plumbing.....5  
Electrical.....6  
Ice Cube Information .....6

**Section 3 Operation**

Initial Start Procedure.....7  
Ice Machine Restart.....7  
Controls and Adjustments.....8  
Sequence of Operation.....9  
Description of Each Process.....10-11

**Section 4 Service Information**

Cleaning Procedure.....12  
Cleaning Mode Start-Up.....13  
Storage and Winterization.....13  
Removal from Service.....13  
Wiring Diagram.....14  
Problems and Solutions.....15-17

## Safety Warnings and Information

Special attention should be given to potential hazard labeling on the equipment and the signal words and symbols that are used throughout this manual. They may also be used to alert against unsafe practices.



**WARNING:** Indicates a potentially hazardous situation that may result in serious injury or death.



**CAUTION:** Indicates a potentially hazardous situation that may result in personal injury. The situation may also result in equipment or property damage.

**NOTE:** Indicates installation, operation, or maintenance information which is important, but not related to personal injury or property damage.

**NOTE:**

- Check for freight damage before proceeding with the equipment installation. Be sure to inspect the equipment carefully for any damage that may not have been evident on the outside of the carton. Contact the freight carrier immediately to report any damage and file a claim. Have carrier note the damage on the bill of lading. Call Kold-Draft with your claim number to arrange replacement or repair.
- Read the entire manual before installing, operating or servicing the machine.
- To ensure optimal efficiency and productivity follow these installation instructions exactly.
- All machines have been tested and adjusted for correct performance at the factory.
- Knowledge of proper installation and service procedures is essential for the safe operation and maintenance of KOLD-DRAFT equipment. Refer all installation and service work to qualified technicians.
- This equipment must be installed in compliance with the applicable federal, state/province, and/or local plumbing, electrical, and health/sanitation codes and requirements.
- Always disconnect the power supply before servicing the equipment or when the equipment will not be used for a period of time. Some circuits remain energized when the machine is switched off.
- Never operate equipment that has been damaged or does not have all the protective covers in place.
- Never operate equipment that has been altered from the original KOLD-DRAFT specifications.



**WARNING:** Use only genuine KOLD-DRAFT replacement parts, Use of non-approved parts when servicing KOLD-DRAFT equipment may create a safety hazard, cause equipment damage, property damage and will void the warranty.

Ice Maker Identification  
Model Number Key

**SC 2 0 1 A C**

**Cube Size**

- C = Full Cube
- HK = Half Cube
- K = Cube-Let

**Condenser Type**

- A = Air cooled condenser-self contained
- L = Liquid cooled condenser-self contained

**Electrical Characteristics**

- 1 = 115 volt-60 hz.-1ph. (2-wire plus ground)
- 4 = 208/230 volt-60 hz.-1ph. (2-wire plus ground)
- 7 = 220/240 volt-50 hz.-1ph. (2-wire plus ground)

**Modification Code**

- 0 = No Modifications

**Series**

- 2 = 200 Series

**Model Family**

- SC = Self Contained

**Date Code Key**

YEAR KEY			
6E = 2015	7A = 2021	7G = 2027	8C = 2033
6F = 2016	7B = 2022	7H = 2028	8D = 2034
6G = 2017	7C = 2023	7J = 2029	8E = 2035
6H = 2018	7D = 2024	8K = 2030	8F = 2036
6J = 2019	7E = 2025	8A = 2031	8G = 2037
7K = 2020	7F = 2026	8B = 2032	8H = 2038
MONTH KEY			
M = JANUARY	R = APRIL	U = JULY	X = OCTOBER
N = FEBRUARY	S = MAY	V = AUGUST	Y = NOVEMBER
P = MARCH	T = JUNE	W = SEPTEMBER	Z = DECEMBER
EXAMPLE			
6EN = FEBRUARY 2015			

**NOTE:** The serial number plate is located in the condensing unit compartment, on the left side wall. A complete model number and date code are essential for the accurate identification of the ice machine and proper selection of replacement parts.

## Installation Information

### **WARNING:**

- Instruct all personnel in the proper use of the equipment.
- Clean up any liquid spills immediately.
- Always install equipment on a stable and level surface.
- All models are intended for indoor use only. Do not install the equipment in unprotected outdoor areas.
- Do not install the equipment in wet areas.
- Do not locate the equipment near any heat source, in direct sunlight, in high ambient areas, or without proper clearance for ventilation. Placing equipment in these locations will result in reduced capacities, high system pressures and may cause equipment failure.

NOTE: Each Kold-Draft ice machine has successfully completed a quality assurance test and has been factory inspected before shipping.

### Unpacking

Unpacking a KOLD-DRAFT machine can be done by prying off the boards that are holding the cardboard box to the shipping pallet. The box can then be lifted vertically to expose the machine.

Remove all packaging materials from the ice machine and protective film from the stainless steel surfaces.

### Carton Contents

- Kold-Draft SC200 Series Ice Machine
- **Warranty card attached to the front of the machine (must be fully completed and returned to the factory within 15 days of installation to register this product and to initiate warranty coverage.)** NOTE: Failure to return this registration form will void your warranty.
- Installation & Operation Manual. Leave these with the owner/user.

## Installation Requirements

- The ice machine must be installed indoors and the location should be free of airborne contaminants including any corrosive elements.
- Ambient air temperatures at the install location must be between 45°F (7°C) and 90°F (32°C). Ambient temperatures higher than the maximum specification will result in reduced capacities and high system pressures in air-cooled models. Temperatures lower than the minimum may cause the machine to be unable to eject the ice from the evaporator. Ambient temperatures less than 60°F (15°C) may cause the bin probe to malfunction.
- The machine may be built into a cabinet. Clearance is not required around the top and sides, but must be provided in back for plumbing and electrical connections and in front for free flow of air in and out of the condensing unit compartment.
- Do not install air cooled units in closets or small rooms where the free flow of air to the unit is restricted.
- The location must not be near heat generating equipment.
- The location must not be near anything that can contaminate it or the ice inside.
- The ice machine should be mounted on the legs provided and leveled by screwing the leg adjusters in or out as required. If the legs are not used, shim the bottom of the machine as required to make it level. Seal any gaps at the floor with approved sealant or use cove molding for larger gaps. Make sure the lower front cover remains removable for service.
- The location must be capable of supporting the weight of the ice machine, with a full bin of ice.

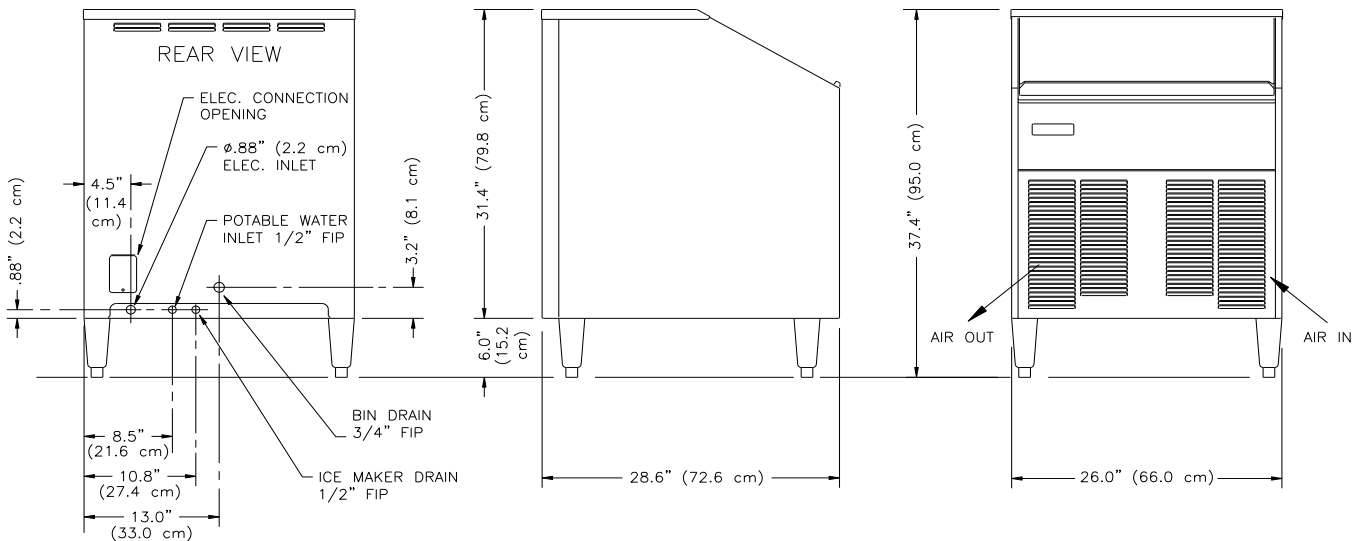

## Plumbing

- The drain hose or pipe must not be reduced in size from the machine to the drain. The building drain must be able to accommodate all the drain water from the ice machine operation.

- Individual drains will not be directly connected to a common manifold, drain or standpipe. If individual drains are to be discharged into a common manifold, drain or standpipe, a minimum 1.5" (38mm) air gap must be provided at each connection. This is to prevent any backflow of drain water into the ice maker or ice bin.

**NOTE: Installation must provide adequate backflow prevention to comply with applicable federal, state and local codes.**

- Drain lines will be installed with a minimum drop of 1/4" per ft. (2.1cm per meter) run. Ice machine drains and bin drains may be insulated to prevent condensation.
- Water supply temperature must be between 45°F (7°C) and 90°F (32°C). Do not connect the ice machine to a hot water supply line. Insulate the water line from sources of heat for greater operating efficiency. Supply water temperatures higher than the recommended maximum will cause reduced capacities.
- The water supply must be potable, not laden with sediment, and have free chlorine levels no greater than 0.2ppm. Supplies with higher chlorine levels should be filtered. There are no specific requirements for water treatment, but the use of water conditioning may increase the intervals between cleaning operations and overall machine life. Please consult a local water conditioning supplier for specific recommendations for your area.
- A minimum 20 psig (dynamic) water supply pressure is required for proper operation of the ice maker water valve. Please note that on liquid cooled ice machines, where the same water supply is used for both condenser cooling and the potable water supply, the demand for condenser coolant may cause the supply pressure to drop. This is most notable at the time of peak load, at the beginning of the freeze cycle. The maximum water supply pressure is 100 psig (0.6 MPA). If a water pressure regulator is used the recommended setting is 30 to 50 psig (0.2 MPA to 0.3 MPA) dynamic.

**All water lines must be purged before connection to the ice machine**

## Electrical

**WARNING:** Failure to comply with these regulations may cause serious injury or death and cause damage to the machine and its surroundings.

**CAUTION:** Switching the machine "off" does not de-energize all circuits. Always disconnect power before servicing.

- All KOLD-DRAFT models are intended to be installed with a permanent connection to the field electrical supply. See rating plate on the back of the machine for power supply requirements.
- Each ice maker must be connected to a separate protected circuit with no other loads.
- Fused disconnects, installed adjacent to each ice maker, are recommended and may be required by local codes. These components must be supplied by the installer.
- Electrical service must fall within the voltage tolerances listed below:

<b>Model</b>	<b>Nominal (V)</b>	<b>No-Load Maximum</b>	<b>Full-Load Minimum</b>
SC201	115	126	104
SC204	208-230	250	198
SC207	230	250	210

Maximum Overload Protection must be no greater than specified. The minimum circuit ampacity specified does not indicate a typical running current value. Use the minimum ampacity value for sizing branch circuit conductors up to 26 feet (8 meters) in length. For a conductor length over this length, increase the wire gauge as required by code.

### **Ice Cube Information**

<b>Cube Type</b>	<b>Cube Dimensions</b>	<b>Cube Weight</b>	<b>Cubes per Cycle</b>
C (Full Cube)	1-1/4 x 1-1/4 x 1-1/4 in (32 x 32 x 32 mm)	1.15 oz (32.6 g)	45
HK (Half Cube)	1-1/4 x 1-1/4 x 5/8 in (32 x 32 x 16 mm)	.53 oz (15.0 g)	90
K (Cublet)	1-1/4 x 5/8 x 5/8 in (32 x 16 x 16 mm)	.28oz (7.9 g)	90

## **Operation**

### **Initial Start Procedure**

11. Be sure that the on-off switch is in the “off” position and the ice-clean switch is in the “ice” position.
12. Make sure all water lines and hoses are securely connected, turn on water supply and check for leaks.
13. Move the on-off switch to the “on” position and observe the water plate opening. Any water in the tank will then be drained. The compressor will turn on, the water plate will close and the sump tank will start to fill.

14. Also, observe that the water pump is circulating water through the system. A momentary sucking, cavitation sound is normal at the beginning of the process when the water level is low. Check that there are no water leaks from the hoses or water tank into the bin.
15. The machine will begin to make ice.
16. When ice is available, test the bin probe adjustment by holding ice against it. Adjust the controller, if required. Code 90 indicates ice bin full, a cold bin probe will shut down the ice machine right after the next harvest is complete.
17. Replace and secure all the cabinet panels.
18. Discard all the ice from the start-up cycles, then clean and sanitize the ice storage bin according to the instructions provided.

## **Ice Machine Re-Start**

**At power up, in the ice making mode, the electronic control will monitor the conditions and operate in the following manner:**

If the evaporator temperature is colder than the harvest termination temperature at start up, the water plate will open (lower).

If there is an obstruction preventing the water plate from closing, it will re-open (lower)

If the evaporator temperature is warmer than the harvest termination temperature and the water plate is open, it will close (raise).

## **Controls and Adjustments**

**On-Off Switch:** Used to turn the ice machine on or off.

**CAUTION:** Switching the machine “off” does not de-energize all circuits. Always disconnect power before servicing.

**Ice-Clean Switch:** The “Ice” position signals the controller to provide full operation of the ice machine. The “Clean” position will exclude operation of the compressor and condenser fan motor (air cooled models) and provide operation required for the cleaning procedure.

**Defrost Button:** Push this button anytime lowering the water plate and/or forcing the ice machine into the defrost mode is desired. The water plate will remain down for four minutes and then return to normal operation. Pushing the button again, while the plate is down, will immediately return the machine to normal operation.

**Float Switch:** Closes water inlet valve when water sump is full

**Evaporator Probe:** Provides evaporator temperature information to the control board to begin and end the defrost cycle. Adjust the left potentiometer on the control board to determine ice cube fullness. Turn CW to extend the freeze time and CCW to shorten it.

**NOTE:** Ice cubes should never be frozen completely full. A small dimple in each cube indicates a proper adjustment. Making cubes without a dimple will reduce ice machine capacity and may cause damage to the water plate and operating mechanism.

**Bin Probe:** This probe will sense contact with the ice, when the bin is full and turn off the ice machine. When ice is used and is no longer in contact the probe, it will signal the control to turn on the ice machine. When the ice machine is off due to a full bin, the code 90 indicator will be lit on the control board. Contact with ice should turn off the ice machine within one minute.

If adjustment is required, hold ice against the probe. Turn the right side potentiometer on the control board CCW to shut off the machine within one minute. CW adjustment is required if the ice machine shuts down, as if the bin is full, when ice has not contacted the probe.

**Plate-Up Switch:** This switch limits the upward travel of the water plate. It opens to de-energize the actuator motor, by way of an operator when its shaft is in the full up (closed) position.

This switch also provides a way for the controller to determine that the plate is blocked. When the plate is closing, the controller provides a time limit for this switch to open. If the time limit is exceeded, the controller will reopen the water plate to clear it. This will repeat until the surface is clear.

**Plate-Down Switch:** This switch limits the downward travel of the water plate. It opens to de-energize the actuator motor, by way of an operator when its shaft is in the full down (open) position.

### Sequence of Operation

The following tables describe the general states and sequence of operation for the ice machine models in ice-making mode with an additional table depicting the status when the ice bin is full and the cleaning mode. The charts provide information about the inputs to the controller and the corresponding AC outputs associated with each part of the ice making cycle.

Note:

- Abnormal operation of the ice machine is covered in the Fault Condition section of the manual.

### Ice Making Sequence

	Step 1 Fill	Step 2 Freeze	Step 3 Lower	Step 4 Harvest	Step 5 Raise
Control	Status	Status	Status	Status	Status
Bin Level Probe	Warm/Not Full	Warm/Not Full	Warm/Not Full	Warm/Not Full	Warm/Not Full
Ice-Clean Switch	Ice	Ice	Ice	Ice	Ice
Harvest Switch	“Run”	“Run”	“Run”	“Run”	“Run”
Evaporator Temperature Probe	N/A	Cold	Cold	Warming	Warm
Plate-Up/Down	Plate Up	Plate Up	Plate Lowering	Plate Down	Plate Rising

Switches					
Ice	None	Forming	Fully Formed	Fully Formed	None
Compressor (Condenser Fan)	On	On	On	On	On
Water Plate	Closed	Closed	Opening	Open	Closing
Water Pump	On	On/Pause/On	Off	Off	On
Defrost Valve	Closed/ De-energized	Closed/ De-energized	Open/ Energized	Open/ Energized	Closed/ De-energized
Water Valve	Open/ Energized	Closed/ De-energized	Closed/ De-energized	Closed/ De-energized	Open/ Energized
Actuator Motor	Off	Off	On/CCW Rotation	Off	On/CW Rotation
Dump Valve	Off	Off	Open/ Energized	Open/ Energized	Closed/ De-energized

## Sequence of Operation

### Description of Each Process

The following sequence begins with the cuber as shipped from the factory with the water plate(s) closed and ready to begin a normal ice making cycle.

**Fill:** The water solenoid valve will be energized until the water level switch indicates that the sump is full. The water pump will run as the water is filling the sump, If the water plate is open, it will close before the pump starts. The water solenoid valve will remain de-energized until the following cycle starts. No additional water will be introduced during the freeze cycle.

**Freeze:** The freeze cycle begins as the sump is filling with water. The water level in the sump will drop as the ice cubes are formed.

**Lower:** When the evaporator outlet reaches the set temperature point the machine will go into harvest. The water plate begins to open and the defrost valve is energized to allow hot gas to circulate through the evaporator. The evaporator warms to begin the ice harvest. The dump valve is also open at this time, to drain the remaining mineral laden water from the sump. When fully open, the water plate will stop.

**Harvest:** The evaporator continues to warm until the ice falls out onto the water plate and into the ice bin. When the evaporator reaches a pre-set temperature, indicating that all the ice has dropped out, the defrost valve is de-energized and the water plate begins to close.

**Raise:** The water solenoid valve will be energized, as the water plate closes, to begin filling the sump for the next ice-making cycle. When fully closed, the water plate will stop and the water pump will be energized. The evaporator cools and begins to remove heat from the water to make the next batch of ice.

**Ice Bin Full:** When the level of ice reaches the bin probe, the ice maker stops automatically, and it remains off until the bin probe warms up when the ice level is lowered.

**Cleaning Mode:** All of the operational components except refrigeration are able to function with the make ice/clean switch in the clean position. Simply placing this switch in the cleaning position does not complete the cleaning and sanitizing of the cuber. Instructions pertaining to the cleaning of a machine can be found on page 12 of this manual.

Note: The frequency of the need for cleaning is determined by the supply water characteristics. The cuber should be cleaned no less frequently than once each 6 months, and it may require more frequent cleaning. The requirement for sanitizing frequency may be contained in local health code regulations.

**Water Plate Closure Problems:** If the water plate is not able to close due to ice remaining on the water plate surface, the plate will reopen until it is clear.

**Shutdown-High Pressure:** All models are provided with a high pressure cutoff, which interrupts power to the compressor and to the condenser fan motor, if so equipped, when the high-side pressure rises to the cutoff setting. The high pressure cutoff will automatically reset, restoring power when the pressure drops. When this happens it is important to determine the cause of the high pressure and correct.

## Maintenance and Service Information

### Ice Machine Cleaning Procedure

**It is recommended to perform this cleaning procedure a minimum of twice per year.**

1. While the ice machine is operating, wait until the ice falls out of the evaporator and the water plate fully returns to the up position. Turn the machine off and empty the storage bin. Move the Ice-Clean Switch to the “Clean” position and turn the ice machine on.
2. While the water plate is filling pour 3 fl. oz. (90 ML) of Kold-Draft nickel-safe ice machine cleaner (Kold-Draft part no. [500023](#)) into the water sump through the opening along its front edge.
3. The cleaning solution will circulate for 20 minutes and then drain. The sump will fill again, with the water circulating and then drain. This will repeat 3 more times, to be sure all the cleaning solution is rinsed out of the machine and then stop. When this process is complete, turn the machine off.
4. Mix a sanitizing solution containing 0.5 ounce (15 ML) 5-1/4% sodium hypochlorite (household bleach or equivalent) and 1 gallon (3.8 liter) warm clean water.
5. Pour the sanitizing solution into the sump. Leaving the Ice-Clean Switch in the “Clean” position turn the machine on.
6. The sanitizing solution will circulate for 20 minutes and then drain. The sump will fill again, with the water circulating and then drain. This will repeat 2 more times, to be sure all the sanitizing solution is rinsed out of the machine and then stop.
7. While these solutions are circulating in the ice machine, clean and sanitize all accessible surfaces of the ice machine and bin. Mix a cleaning solution as follows: 8 tablespoons (1/2 cup) (96g) baking soda and 1 gallon (3.8 liter) of warm clean water. Mix a sanitizing solution as follows: 2 teaspoon (10 ML) 5-1/4% sodium hypochlorite and 1 gallon (3.8 liter) of warm clean water. Use clean towels to apply these solutions and rinse well when done.
8. After all cleaning, sanitizing and rinsing has been completed turn the machine off. Move the Ice-Clean Switch to the “Ice” position. Check for proper operation of the machine and dispose of the first batch of ice.

### **Cleaning Mode Start Up**

**At power up in the wash mode the electronic control will monitor the following criteria:**

If the water plate is not in the full up (closed) position at start up, the controller will close the plate.

If there is ice on the surface of the water plate, preventing it from closing, the controller will reopen the plate to clear it.

## **Storage and Winterization**

Clean and sanitize the ice machine.

Disconnect the electric power supply.

Disconnect water and drain lines.

Remove and empty the water sump.

Open water valve and dump valve and blow compressed air through all lines.

Remove and drain the water plate assembly.

Reassemble water plate assembly and water sump.

Replace all cabinet panels.

## **Removal from Service**

When the ice maker is determined to be no longer useable please be sure that it is rendered safe for storage or disposal. All applicable recycling measures should be exercised to avoid injury and harm to the environment.

The manufacturer and/or seller are not responsible for any harm to people, animals, property, and the environment caused by incorrect installation and/or disposal

## **Wiring Diagram**

ITEM	DESCRIPTION
D1	HIGH PRESSURE CUT-OFF
M1	COMPRESSOR
M2	CONDENSER FAN MOTOR (AIR COOLED)
M3	WATER PUMP
M4	ACTUATOR MOTOR
OL1	OVERLOAD
R1	RELAY
S1	ON-OFF SWITCH
S2	ARMS UP SWITCH
S3	MANUAL DEFROST
S4	ARMS DOWN SWITCH
S5	ICE-CLEAN SWITCH
S6	FLOAT SWITCH
SC1	START CAPACITOR
SR1	START RELAY (CURRENT)
T1	EVAPORATOR THERMISTOR
T2	BIN THERMISTOR
V1	WATER VALVE
V2	DEFROST VALVE
V4	DUMP VALVE

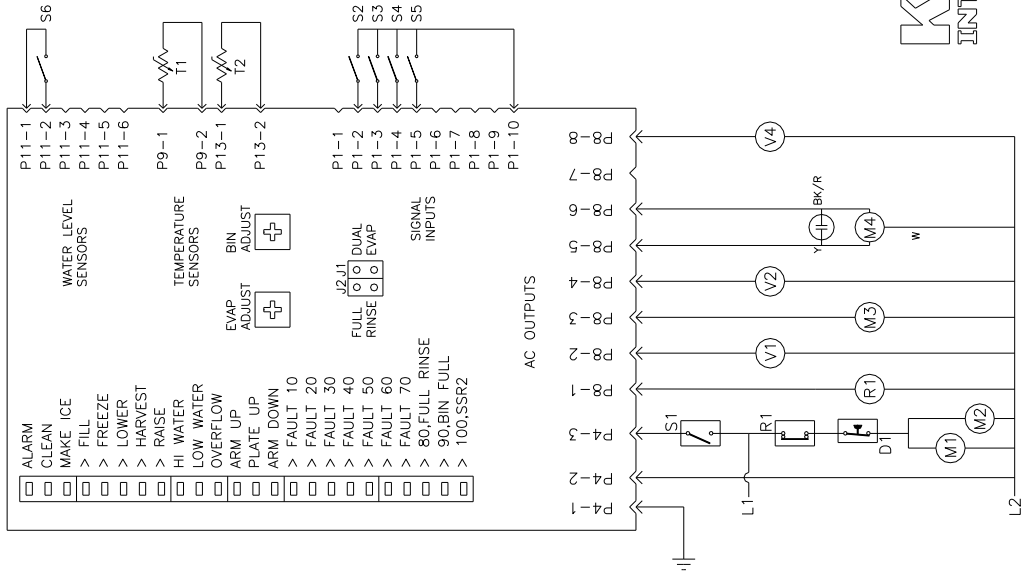

THE ELECTRONIC CONTROL WILL MONITOR FOR THE FOLLOWING CONDITIONS AND PREVENT THE ICE MACHINE FROM OPERATING AS REQUIRED TO PREVENT DAMAGE.

LED\_10—EVAPORATOR PROBE NOT CONNECTED OR DAMAGED.

LED\_20—WATER PLATE HAS RE-OPENED 13 CONSECUTIVE TIMES WITHOUT STARTING A FREEZE CYCLE.

LED\_30—FREEZE CYCLE EXCEEDS 45 MINUTES. FLASHES AFTER 3 CONSECUTIVE 45-MINUTE CYCLES.

LED\_40—FREEZE CYCLE SHORTER THAN 5 MINUTES. FLASHES AFTER 3 CONSECUTIVE ATTEMPTS AND CIRCULATES WATER SOLID AFTER 6 CONSECUTIVE ATTEMPTS.

LED\_60—WATER FILL EXCEEDS 3 MINUTES.

LED\_70—CAM SWITCH FAULT—BOTH ARM-UP AND ARM-DOWN SWITCHES ARE ENGAGED AT THE SAME TIME.

LED\_80—NO JUMPER ON J2. (NO FUNCTIONAL SIGNIFICANCE)

LED\_90—BIN FULL—BIN PROBE'S TEMPERATURE IS LESS THAN THE BIN ADJUST'S SETPOINT

SC200 SERIES  
AIR COOLED

**KOLDO-DRAFT**  
INTERNATIONAL,LLC  
ERIE,PA,USA

507 1093 01

### Problems and Solutions

PROBLEM	POSSIBLE CAUSE	SOLUTION
---------	----------------	----------

Ice machine is not operating.	On-Off switch in "Off" position	Move switch to "On" position.
	No power at ice machine. Circuit protector open.	Reset breaker. Check circuit for overload condition.
	Ice machine off because bin is full of ice.	Use ice or move ice away from bin probe.
	Ice machine off because bin probe is defective.	Replace bin probe.
	Ice machine off as if bin is full. Ambient temp below 50°F (10°C).	Ambient temperature must be 60°F (15°C) minimum.
Condenser fan motor is not operating on air-cooled models. Compressor is operating	Ice-Clean switch in "Clean" position.	Move switch to "Ice" position.
	High pressure cut-out open on air cooled models. Condenser dirty.	Clean condenser. Confirm proper operating pressures.
	High pressure cut-out open on air cooled models. Air circulation through condenser is insufficient or hot air is re-circulating through the condenser.	Provide adequate spacing between the ice machine and walls, ceilings or other equipment. See installation instructions for spacing requirements. Confirm proper pressures.
	High pressure cut-out open. Refrigeration system is overcharged.	Remove refrigerant and recharge the system to specifications.
	Compressor thermal protector is open because of low voltage condition.	Allow thermal protector to reset. Measure voltage at relay while compressor is running. Correct power supply problem if voltage is lower than specified on the ice machine electrical plate.
	Compressor thermal protector is open because of defective run capacitor.	Replace run capacitor.
	Relay is defective.	Check for voltage at terminals. Replace relay if it does not close when the coil is energized.
	Compressor start capacitor or relay defective	Test and replace these parts if defective.
Compressor is defective.	Replace compressor.	
Condenser fan motor is not operating on air-cooled models. Compressor is operating	Fan motor protector open.	Replace motor if it does not run when cool or at normal operating conditions.
	Fan motor defective	Replace motor.
Water plate re-opens immediately after closing	"Plate up" switch lever is not being pushed up completely.	Adjust "Plate up" switch actuator near water plate until it releases the switch lever completely.
	Water plate is prevented from closing by some obstruction such as ice remaining on the water plate surface.	Eliminate obstruction.

## Problems and Solutions

PROBLEM	POSSIBLE CAUSE	SOLUTION
---------	----------------	----------

Water plate will not close after defrost.	Actuator motor output shaft is turning but front cam is not turning.	Connection between actuator motor shaft and right side operator broken. Check set screw, tighten or replace.
	Actuator motor will not run. No voltage measured at actuator motor.	Inspect operation of plate up and plate down switches. Adjust or replace if defective.
Defrost cycle ends before all ice is out of the evaporator	Evaporator grids are distorted, slowing the fall of the ice from the evaporator.	Carefully straighten grids or replace evaporator if the damage is severe.
	Excessive scale build-up in evaporator cells	Clean and de-scale ice machine
Ice remains attached to the water plate surface at the end of defrost.	Ice frozen into the water plate surface. Thick web between ice cubes.	Adjust web thickness to specifications.
	Over-freezing	Increase the temperature set point that initiates harvest.
	Cold potable water supply.	Make sure water supply temperature is within the acceptable range.
Water valve will not close. Potable water level continues to rise after the float is fully up.	No voltage measured at water valve coil. Water valve remains open because of water supply problem.	The water supply pressure must be a minimum of 5 PSI (34 KPA) dynamic at the water valve. Be sure that the supply line is of adequate size. This is especially important for liquid cooled models where the potable water and condenser coolant water are supplied by the same water line. Check for restrictions in the water supply line including clogged filters. Check the water valve strainer and clean it if needed.
	No voltage measured at water valve coil. Water valve remains open because of dirty or defective water valve.	Disassemble and clean water valve if needed. Make sure the bleed holes in the valve diaphragm are open. Replace water valve if defective.
	Line voltage measured at water valve coil.	Test for proper water float switch operation. Reed switch could be defective.
	Water level float switch OK, but line voltage measured at water valve coil.	Check controller for output to water valve. Controller could be defective

### Problems and Solutions

PROBLEM	POSSIBLE CAUSE	SOLUTION
---------	----------------	----------

Water valve will not open. Potable water level never reaches the high water level during the fill cycle.	No voltage measured at water valve coil at fill cycle.	Float switch defective.
	Float switch, OK but no voltage measured at water valve coil at fill cycle.	Check for line voltage at controller output to water valve. Controller could be defective.
Actuator motor turns wrong way at start or end of defrost. When viewed from left side, CW to open and CCW to close.	Relationship between water plate up or down switch and its operator is incorrect.	Adjust operators as required for proper operation
	Water plate up or down switch defective.	Replace switch