



Model: KCHMT29.12.2D

PNC: 738286

REV: 6/5/2024

Spare Parts List

NO	DESCRIPTION	Serial #	QTY	COMPONENT PNC	Model Number	Model PNC
2	TEMPERATURE CONTROLLER	<01021232	1PC	0USF42	KCHMT29.12.2D	738286
		≥01021232	1PC	0USDET	KCHMT29.12.2D	738286
2a	Inner Chest Temperature Sensor Probe	ALL	1PC	0USC4C	KCHMT29.12.2D	738286
2b	Controller Mounting Plate	ALL	1PC	0USDIF	KCHMT29.12.2D	738286
8	CABLE COVER	ALL	1PC	0USK07	KCHMT29.12.2D	738286
9	BRAKE WHEEL	ALL	2PCS	0USF03	KCHMT29.12.2D	738286
10	FRONT SUPPORT OF UNIT BOARD	ALL	1PC	0USJ55	KCHMT29.12.2D	738286
11	NORMAL WHEEL	ALL	2PCS	0USH63	KCHMT29.12.2D	738286
11a	Castor Mounting Bolt (4-PACK)	ALL	4PC	0USC2U	KCHMT29.12.2D	738286
11b	Castor Mounting Locking Washer (4-PACK)	ALL	4PC	0USC4A	KCHMT29.12.2D	738286
11c	Castor Mounting Flat Washer (4-PACK)	ALL	4PC	0USC2X	KCHMT29.12.2D	738286
12	BACK SUPPORT OF UNIT BOARD	ALL	1PC	0USJ56	KCHMT29.12.2D	738286
14	BODY	ALL	1PC	N/A	KCHMT29.12.2D	738286
15	TOP CLIP	ALL	4PCS	0USL80	KCHMT29.12.2D	738286
16	UNIT ROOM COVER	ALL	1PC	0USI09	KCHMT29.12.2D	738286
17	PLUG	ALL	1PC	0USH67	KCHMT29.12.2D	738286
18	LOCATION KNOB	ALL	2PCS	0USH46	KCHMT29.12.2D	738286
19	FIXED CLIP OF CUTTING BOARD	ALL	2PCS	0USG68	KCHMT29.12.2D	738286
20	CUTTING BOARD	ALL	1PC	0USF48	KCHMT29.12.2D	738286
21	TOP	ALL	1PC	0USH96	KCHMT29.12.2D	738286
22	PAN SUPPORT /FRONT/BACK	ALL	2PCS	0USJ29	KCHMT29.12.2D	738286
22a	Support Screw	ALL		0USM14	KCHMT29.12.2D	738286
23	STANDARD PAN	ALL	12PCS	N/A	KCHMT29.12.2D	738286
24	PAN SUPPORT /LEFT/RIGHT	ALL	2PCS	0USJ32	KCHMT29.12.2D	738286
25	PAN SUPPORT	ALL	3PCS	0USJ31	KCHMT29.12.2D	738286
26	HANDLE OF COVER	ALL	1PC	0USH09	KCHMT29.12.2D	738286

27	MOVING COVER	ALL	1PC	0USH60	KCHMT29.12.2D	738286
27a	MOVING COVER LINER	ALL	1PC	0USL28	KCHMT29.12.2D	738286
28	FIXED COVER	ALL	1PC	0USG70	KCHMT29.12.2D	738286
28a	FIXED COVER LINER	ALL	1PC	0USL68	KCHMT29.12.2D	738286
29	CONDENSER	ALL	1PC	0USF34	KCHMT29.12.2D	738286
30	FILTER DRIER	ALL	1PC	0USG65	KCHMT29.12.2D	738286
31	DRIER SUPPORT	ALL	1PC	0USI78	KCHMT29.12.2D	738286
32	CAPILLARY	ALL	1PC	0USM33	KCHMT29.12.2D	738286
33	CONDENSER FAN	ALL	1PC	0USF40	KCHMT29.12.2D	738286
33a	CONDENSER FAN BLADE	ALL	1PC	0USC4J	KCHMT29.12.2D	738286
34	Basket Guard Grills	ALL	1PC	0USDIJ	KCHMT29.12.2D	738286
35	EVAPORATE PIPE	ALL	1PC	0USM41	KCHMT29.12.2D	738286
36	WATER BOX	ALL	1PC	0USI34	KCHMT29.12.2D	738286
37	COMPRESSOR	ALL	1PC	0USF23	KCHMT29.12.2D	738286
37a	COMPRESSOR ELECTRICAL COMPONENT SET	ALL	1PC	0USDF0	KCHMT29.12.2D	738286
38	SUCTION PIPE	ALL	1PC	0USH79	KCHMT29.12.2D	738286
39	CONNECTOR SUPPORT	ALL	1PC	0USDEE	KCHMT29.12.2D	738286
40	CABLE CONNECTOR	ALL	1PC	0USF09	KCHMT29.12.2D	738286
41	CONNECTOR COVER	ALL	1PC	0USJ98	KCHMT29.12.2D	738286
42	UNIT BOARD	ALL	1PC	0USK24	KCHMT29.12.2D	738286
44	CIRCLE FAN	ALL	2PCS	0USF14	KCHMT29.12.2D	738286
45	CIRCLE FAN SUPPORT	ALL	1PC	0USJ99	KCHMT29.12.2D	738286
46	EVAPORATOR	ALL	1PC	0USG29	KCHMT29.12.2D	738286
46a	Evaporator Temperature Sensor Probe	ALL	1PC	0USC6R	KCHMT29.12.2D	738286
47	EVAPORATOR WATER PAN	ALL	1PC	0USG54	KCHMT29.12.2D	738286
48	FIXED SUPPORT OF EVAPORATOR COVER	ALL	2PCS	0USK05	KCHMT29.12.2D	738286
49	EVAPORATOR COVER	ALL	1PC	0USJ97	KCHMT29.12.2D	738286
51	SENSOR FIXED CLIP	ALL	1PC	0USM10	KCHMT29.12.2D	738286
62	CONDUCT BOARD	ALL	1PC	0USK01	KCHMT29.12.2D	738286

62a	CONDUCT BOARD SIDE PLATE	ALL	2PCS	0USL29	KCHMT29.12.2D	738286
63	FIXED BOLT	ALL	2PCS	0USG67	KCHMT29.12.2D	738286
64	FIXED NUT	ALL	2PCS	0USG73	KCHMT29.12.2D	738286
65	BACK FRAME	ALL	1PC	0USM42	KCHMT29.12.2D	738286
66	FRONT FRAME	ALL	1PC	0USM43	KCHMT29.12.2D	738286
66a	FRONT FRAME COVER (TOP)	ALL	1PC	0USM04	KCHMT29.12.2D	738286
66b	FRONT FRAME COVER (BOTTOM)	ALL	1PC	0USM04	KCHMT29.12.2D	738286
66c	FRONT FRAME COVER (LEFT)	ALL	1PC	0USM05	KCHMT29.12.2D	738286
66d	FRONT FRAME COVER (RIGHT)	ALL	1PC	0USDEG	KCHMT29.12.2D	738286
67	BRIDGE	ALL	1PC	0USM44	KCHMT29.12.2D	738286
68	GASKET	ALL	2PCS	0USM45	KCHMT29.12.2D	738286
69	GUIDE (RIGHT)	<33920034	2PCS	0USM46	KCHMT29.12.2D	738286
		≥33920034	2PCS	0USE8B	KCHMT29.12.2D	738286
70	GUIDE (LEFT)	<33920034	2PCS	0USM47	KCHMT29.12.2D	738286
		≥33920034	2PCS	0USE8A	KCHMT29.12.2D	738286
71	DRAWER PANNEL	ALL	2PCS	0USM48	KCHMT29.12.2D	738286
71a	DRAWER BODY	ALL	2PCS	0USM49	KCHMT29.12.2D	738286
72	BACK FRAME CLIP	ALL	2PCS	0USM50	KCHMT29.12.2D	738286
73	DRAWER SUPPORT	ALL	2PCS	0USM51	KCHMT29.12.2D	738286
74	FRONT SUPPORT	ALL	2PCS	0USM52	KCHMT29.12.2D	738286

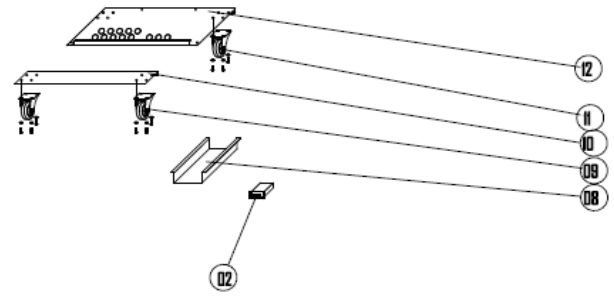
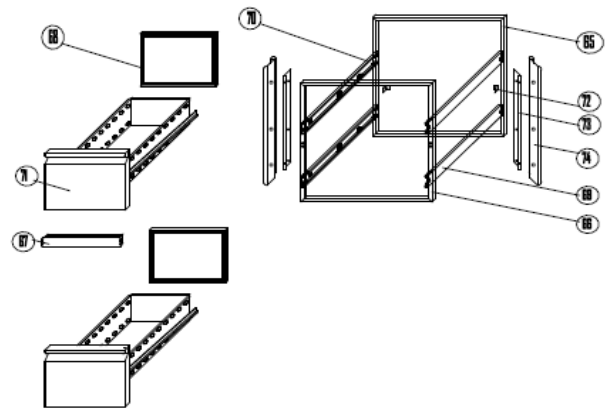
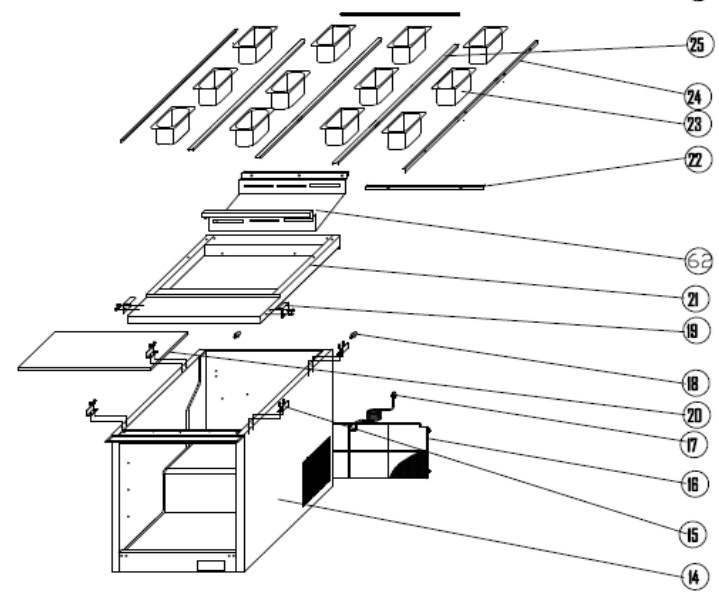
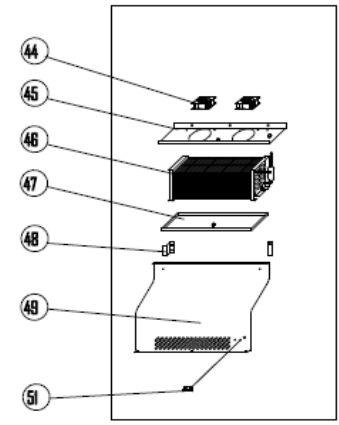
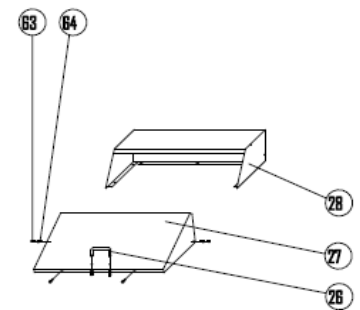
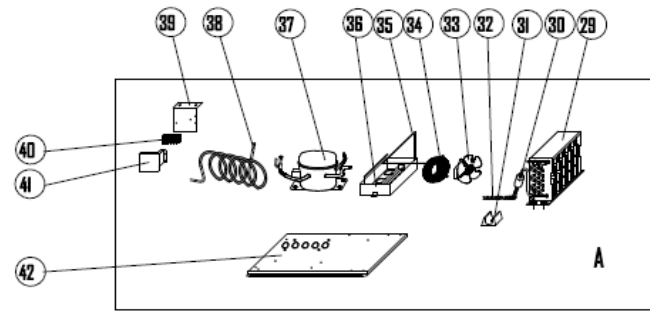

EXPLODE OF KCHMT29.12.2D