



COMMERCIAL

Spare Parts List

Model: KCHUC48F

PNC: 738266

REV: 2/18/2025

NO	DESCRIPTION	Serial #	QTY	COMPONENT PNC	Model Number	Model PNC
3	Temperature Controller	<03021184	1PC	0USH92	KCHUC48F	738266
		≥03021184	1PC	0USDES	KCHUC48F	738266
3a	Inner Chest Temperature Sensor Probe	ALL	1PC	0USC4F	KCHUC48F	738266
3b	Controller Mounting Plate	ALL	1PC	0USDIF	KCHUC48F	738266
5	Sensor Fixed Clip	ALL	1PC	0USM10	KCHUC48F	738266
7	Evaporator Cover	ALL	1PC	0USK10	KCHUC48F	738266
8	FIXED SUPPORT OF EVAPORATOR COVER	ALL	2PCS	0USK05	KCHUC48F	738266
9	EVAPORATOR WATER PAN	ALL	1PC	0USG59	KCHUC48F	738266
9a	DRAIN PIPE(A INT)	ALL	1PC	096263	KCHUC48F	738266
9b	DRAIN PIPE(B EXT)	ALL	1PC	0USG04	KCHUC48F	738266
9c	DRAIN FIXER	ALL	1PC	0USN75	KCHUC48F	738266
9d	DRAIN PIPE	ALL	1PC	0USM54	KCHUC48F	738266
10	Protector For Heating Element	ALL	1PC	0USH71	KCHUC48F	738266
11	Defrost Heating Element	ALL	1PC	0USF56	KCHUC48F	738266
12	Evaporator	ALL	1PC	0USG36	KCHUC48F	738266
12a	Evaporator Temperature Sensor Probe	ALL	1PC	0USC6U	KCHUC48F	738266
13	Circle Fan Support	ALL	1PC	0USK33	KCHUC48F	738266
14	Circle Fan	ALL	2PCS	096250	KCHUC48F	738266
15	Normal Wheel	ALL	2PCS	0USH63	KCHUC48F	738266
16	Lower Door Hinge/Right	ALL	1PC	0USF81	KCHUC48F	738266
17	Body	ALL	1PC	N/A	KCHUC48F	738266
18	Top Clip	ALL	2PCS	0USL80	KCHUC48F	738266
19	Unit Room Cover	ALL	1PC	0USI14	KCHUC48F	738266
20	PLUG	ALL	1PC	0USH67	KCHUC48F	738266
21	Location Knob	ALL	2PCS	0USH46	KCHUC48F	738266
22	Top	ALL	1PC	0USI01	KCHUC48F	738266
23	Condenser	<03321310	1PC	0USF34	KCHUC48F	738266
		≥03321310	1PC	0USO57	KCHUC48F	738266
24	FILTER DRIER	ALL	1PC	0USG65	KCHUC48F	738266
24a	CAPILLARY	ALL	1PC	0USL77	KCHUC48F	738266
25	CONDENSER FAN	ALL	1PC	0USF40	KCHUC48F	738266
25a	CONDENSER FAN BLADE	ALL	1PC	0USC4J	KCHUC48F	738266
26	Basket Guard Grills	ALL	1PC	0USDIJ	KCHUC48F	738266
27	EVAPORATE PIPE	ALL	1PC	0USG14	KCHUC48F	738266
28	WATER BOX	ALL	1PC	0USI35	KCHUC48F	738266
29	COMPRESSOR	ALL	1PC	0USF28	KCHUC48F	738266
29a	COMPRESSOR ELECTRICAL COMPONENT SET	ALL	1PC	0USDF5	KCHUC48F	738266
30	Suction Pipe	ALL	1PC	0USO27	KCHUC48F	738266
31	CONNECTOR SUPPORT	ALL	1PC	0USDEE	KCHUC48F	738266
32	Cable Connector	ALL	1PC	0USF09	KCHUC48F	738266
33	CONNECTOR COVER	ALL	1PC	0USJ98	KCHUC48F	738266
34	GUIDE OF UNIT BOARD/LEFT	ALL	1PC	0USK50	KCHUC48F	738266
35	UNIT BOARD	ALL	1PC	0USK32	KCHUC48F	738266
36	SHELF SUPPORT B	ALL	4PCS	0USI66	KCHUC48F	738266
36a	Shelf Support Screw	ALL	8PCS	0USM14	KCHUC48F	738266
37	Shelf	ALL	2PCS	0USCOM	KCHUC48F	738266
38	SHELF SUPPORT A	ALL	4PCS	0USI44	KCHUC48F	738266
38a	Shelf Support Screw	ALL	12PCS	0USM14	KCHUC48F	738266
39	K Shape Clip	ALL	8PCS	0USH19	KCHUC48F	738266
40	Up Hinge/Left	ALL	1PC	0USI16	KCHUC48F	738266
41	UP HINGE /RIGHT	ALL	1PC	0USI17	KCHUC48F	738266

42	BUSHING	ALL	2PCS	096268	KCHUC48F	738266
43	DOOR SPRING HINGE	ALL	2PCS	0USF83	KCHUC48F	738266
44	DOOR/LEFT	ALL	1PC	0USM97	KCHUC48F	738266
45	GASKET	ALL	2PCS	0USH00	KCHUC48F	738266
46	RIGHT DOOR	ALL	1PC	0USM98	KCHUC48F	738266
47	DOOR SWITCH	ALL	2PCS	096253	KCHUC48F	738266
48	Door Switch Case	ALL	2PCS	0USF88	KCHUC48F	738266
50	CABLE COVER	ALL	1PC	0USK07	KCHUC48F	738266
51	BRAKE WHEEL	ALL	2PCS	0USF03	KCHUC48F	738266
51a	Castor Mounting Bolt (4-PACK)	ALL	4PC	0USC2U	KCHUC48F	738266
51b	Castor Mounting Locking Washer (4-PACK)	ALL	4PC	0USC4A	KCHUC48F	738266
51c	Castor Mounting Flat Washer (4-PACK)	ALL	4PC	0USC2X	KCHUC48F	738266
52	FRONT SUPPORT OF UNIT BOARD	ALL	1PC	0USJ59	KCHUC48F	738266
53	BACK SUPPORT OF UNIT BOARD	ALL	1PC	0USJ60	KCHUC48F	738266
54	Lower Door Hinge/Left	ALL	1PC	0USF80	KCHUC48F	738266
55	GUIDE OF UNIT BOARD/RIGHT	ALL	1PC	0USK49	KCHUC48F	738266
56	DRIER SUPPORT	ALL	1PC	0USI78	KCHUC48F	738266
57	Middle Girder	ALL	1PC	0USC6C	KCHUC48F	738266
58	Middle Girder Fixer	ALL	2PCS	0USH59	KCHUC48F	738266
59	Transformer	ALL	1PC	096252	KCHUC48F	738266
60	Unit Room Cover - Bottom	<9052150		N/A	KCHUC48F	738266
		≥9052150	1PC	0USFAH	KCHUC48F	738266

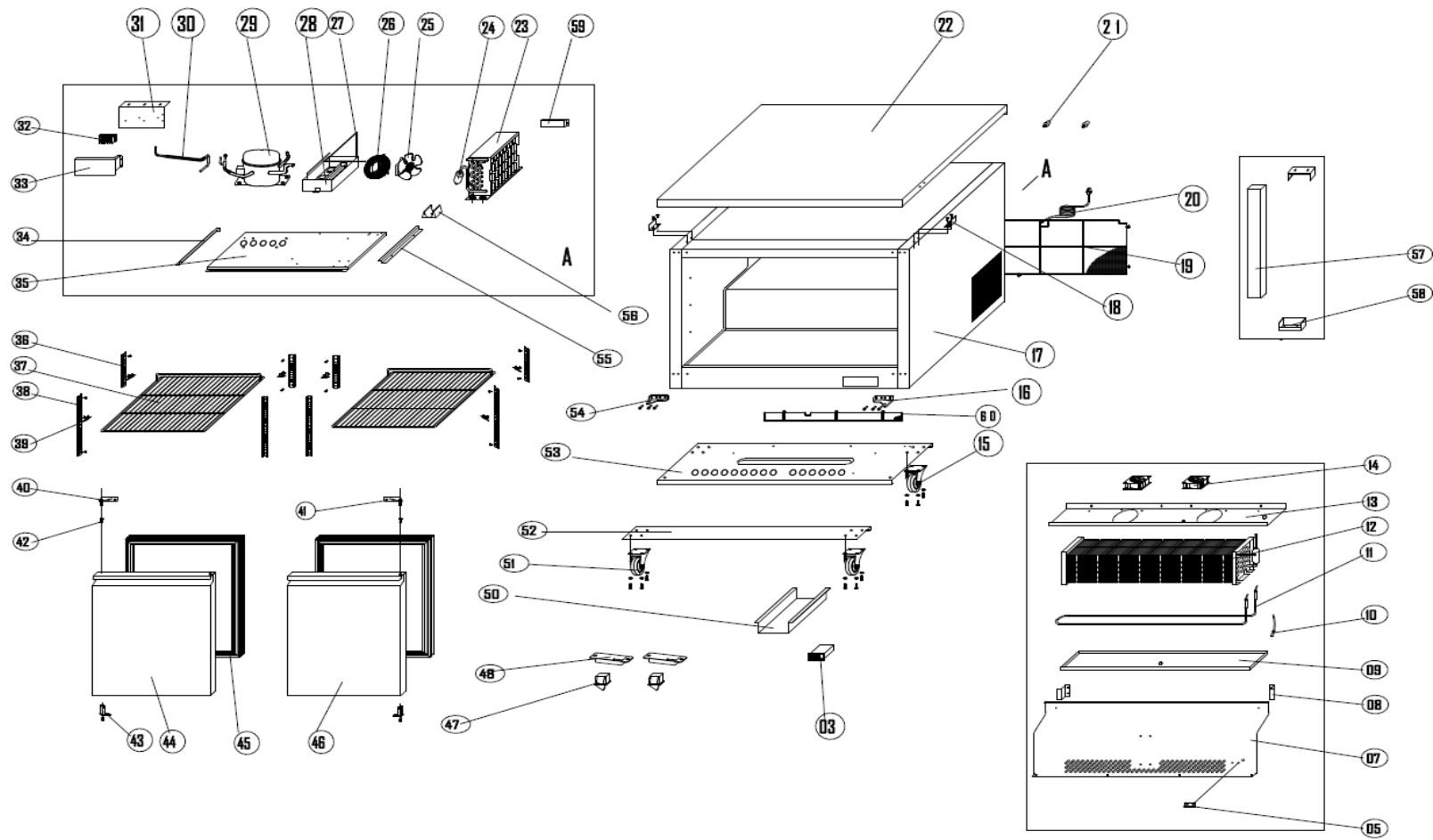

EXPLODE OF KCHUC48F