



Model: KCHUCWT48F

PNC: 738304

REV: 2/18/2025

Spare Parts List

NO	DESCRIPTION	Serial #	QTY	COMPONENT PNC	Model Number	Model PNC
3	Thermostat Controller	<01821644	1PC	0USH92	KCHUCWT48F	738304
		≥01821644	1PC	0USDES	KCHUCWT48F	738304
3a	Inner Chest Temperature Sensor Probe	ALL	1PC	0USC4F	KCHUCWT48F	738304
3b	Controller Mounting Plate	ALL	1PC	0USDIF	KCHUCWT48F	738304
5	Sensor Fixed Clip	ALL	1PC	0USM10	KCHUCWT48F	738304
7	Evaporator Cover	ALL	1PC	0USK10	KCHUCWT48F	738304
8	FIXED SUPPORT OF EVAPORATOR COVER	ALL	2PCS	0USK05	KCHUCWT48F	738304
9	EVAPORATOR WATER PAN	ALL	1PC	0USG59	KCHUCWT48F	738304
9a	DRAIN PIPE(A INT)	ALL	1PC	096263	KCHUCWT48F	738304
9b	DRAIN PIPE(B EXT)	ALL	1PC	0USG04	KCHUCWT48F	738304
9c	DRAIN FIXER	ALL	1PC	0USN75	KCHUCWT48F	738304
9d	DRAIN PIPE	ALL	1PC	0USM54	KCHUCWT48F	738304
10	Protector For Heating Element	ALL	1PC	0USH71	KCHUCWT48F	738304
11	Defrost Heating Element	ALL	1PC	0USF56	KCHUCWT48F	738304
12	Evaporator	ALL	1PC	0USG36	KCHUCWT48F	738304
12a	Evaporator Temperature Sensor Probe	ALL	1PC	0USC6U	KCHUCWT48F	738304
13	Circle Fan Support	ALL	1PC	0USK33	KCHUCWT48F	738304
14	Circle Fan	ALL	2PCS	096250	KCHUCWT48F	738304
15	Normal Wheel	ALL	2PCS	0USH63	KCHUCWT48F	738304
16	Lower Door Hinge/Right	ALL	1PC	0USF81	KCHUCWT48F	738304
17	Body	ALL	1PC	N/A	KCHUCWT48F	738304
18	Top Clip	ALL	2PCS	0USL80	KCHUCWT48F	738304
19	Unit Room Cover	ALL	1PC	0USI14	KCHUCWT48F	738304
20	PLUG	ALL	1PC	0USH67	KCHUCWT48F	738304
21	Location Knob	ALL	2PCS	0USH46	KCHUCWT48F	738304
22	Top	ALL	1PC	0USO37	KCHUCWT48F	738304
23	Condenser	<03321104	1PC	0USF34	KCHUCWT48F	738304
		≥03321104	1PC	0USO57	KCHUCWT48F	738304
24	FILTER DRIER	ALL	1PC	0USG65	KCHUCWT48F	738304
24a	CAPILLARY	ALL	1PC	0USL77	KCHUCWT48F	738304
25	CONDENSER FAN	ALL	1PC	0USDGW	KCHUCWT48F	738304
25a	CONDENSER FAN BLADE	ALL	1PC	0USC4J	KCHUCWT48F	738304
26	Basket Guard Grills	ALL	1PC	0USDIJ	KCHUCWT48F	738304
27	EVAPORATE PIPE	ALL	1PC	0USG14	KCHUCWT48F	738304
28	WATER BOX	ALL	1PC	0USI35	KCHUCWT48F	738304
29	COMPRESSOR	ALL	1PC	0USF28	KCHUCWT48F	738304
29a	COMPRESSOR ELECTRICAL COMPONENT SET	ALL	1PC	0USDF5	KCHUCWT48F	738304
30	Suction Pipe	ALL	1PC	0USO27	KCHUCWT48F	738304
31	CONNECTOR SUPPORT	ALL	1PC	0USDEE	KCHUCWT48F	738304
32	Cable Connector	ALL	1PC	0USF09	KCHUCWT48F	738304
33	CONNECTOR COVER	ALL	1PC	0USJ98	KCHUCWT48F	738304
34	GUIDE OF UNIT BOARD/LEFT	ALL	1PC	0USK50	KCHUCWT48F	738304
35	UNIT BOARD	ALL	1PC	0USK32	KCHUCWT48F	738304
36	SHELF SUPPORT B	ALL	4PCS	0USI66	KCHUCWT48F	738304
36a	Shelf Support Screw	ALL	8PCS	0USM14	KCHUCWT48F	738304
37	Shelf	ALL	2PCS	0USCOM	KCHUCWT48F	738304
38	SHELF SUPPORT A	ALL	4PCS	0USI44	KCHUCWT48F	738304
38a	Shelf Support Screw	ALL	12PCS	0USM14	KCHUCWT48F	738304
39	K Shape Clip	ALL	8PCS	0USH19	KCHUCWT48F	738304
40	Up Hinge/Left	ALL	1PC	0USI16	KCHUCWT48F	738304
41	UP HINGE /RIGHT	ALL	1PC	0USI17	KCHUCWT48F	738304

42	BUSHING	ALL	2PCS	096268	KCHUCWT48F	738304
43	DOOR SPRING HINGE	ALL	2PCS	0USF83	KCHUCWT48F	738304
44	DOOR/LEFT	ALL	1PC	0USM97	KCHUCWT48F	738304
45	GASKET	ALL	2PCS	0USH00	KCHUCWT48F	738304
46	RIGHT DOOR	ALL	1PC	0USM98	KCHUCWT48F	738304
47	DOOR SWITCH	ALL	2PCS	096253	KCHUCWT48F	738304
48	Door Switch Case	ALL	2PCS	0USF88	KCHUCWT48F	738304
50	CABLE COVER	ALL	1PC	0USK07	KCHUCWT48F	738304
51	BRAKE WHEEL	ALL	2PCS	0USF03	KCHUCWT48F	738304
51a	Castor Mounting Bolt (4-PACK)	ALL	4PC	0USC2U	KCHUCWT48F	738304
51b	Castor Mounting Locking Washer (4-PACK)	ALL	4PC	0USC4A	KCHUCWT48F	738304
51c	Castor Mounting Flat Washer (4-PACK)	ALL	4PC	0USC2X	KCHUCWT48F	738304
52	FRONT SUPPORT OF UNIT BOARD	ALL	1PC	0USJ59	KCHUCWT48F	738304
53	BACK SUPPORT OF UNIT BOARD	ALL	1PC	0USJ60	KCHUCWT48F	738304
54	Lower Door Hinge/Left	ALL	1PC	0USF80	KCHUCWT48F	738304
55	GUIDE OF UNIT BOARD/RIGHT	ALL	1PC	0USK49	KCHUCWT48F	738304
56	DRIER SUPPORT	ALL	1PC	0USI78	KCHUCWT48F	738304
57	Middle Girder	ALL	1PC	0USC6C	KCHUCWT48F	738304
58	Middle Girder Fixer	ALL	2PCS	0USH59	KCHUCWT48F	738304
59	Transformer	ALL	1PC	096252	KCHUCWT48F	738304
60	Unit Room Cover - Bottom	<9052152		N/A	KCHUCWT48F	738304
		≥9052152	1PC	0USFAH	KCHUCWT48F	738304

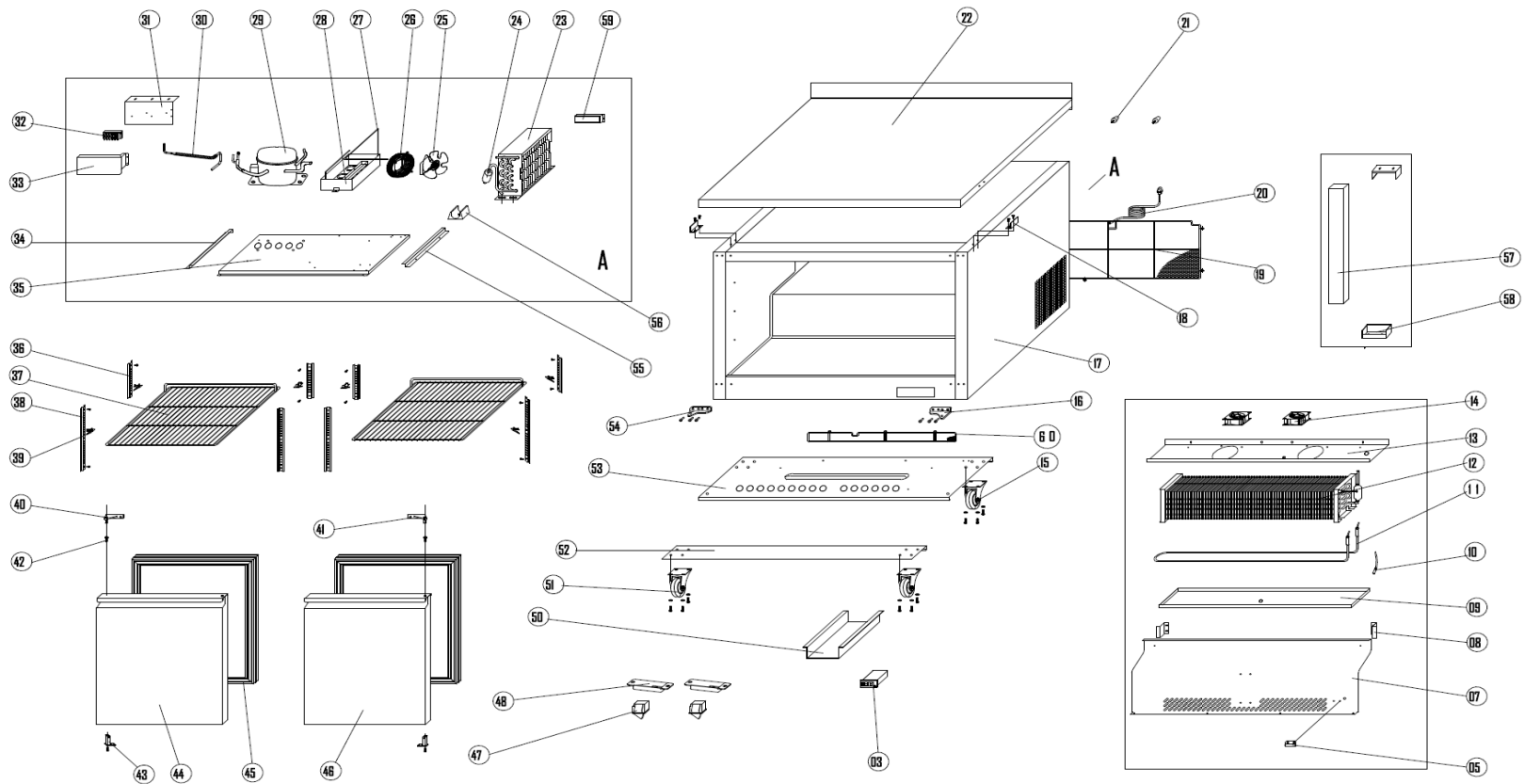

EXPLODE OF KCHUCWT48F