



## **INSTRUCTION MANUAL EQUIPMENT STAND**

**2-Drawer Models KE036, KE048 & KE060**

**4-Drawer Models KE065, KE072 & KE084**

**6-Drawer Models KE096, KE110 & KE125**

**8-Drawer Model KE139**

500 S. State College Blvd. Fullerton, CA 92831 | Phone: (714) 870-8661 Toll-Free: (800) 833-1106 Fax: (714) 870-6473

[www.kairak.com](http://www.kairak.com)

© KAIRAK, a division of ITW Food Equipment Group LLC. All Rights Reserved.

# TABLE OF CONTENTS

<b>1. THE SERIAL TAG</b>	<b>PAGE 3</b>
<b>2. RECEIPT INSPECTION</b>	<b>PAGE 4</b>
<b>3. INSTALLATION</b>	<b>PAGE 4</b>
A-Location	<b>PAGE 4</b>
B-Packaging	<b>PAGE 5</b>
C-Adjusting the Casters	<b>PAGE 5</b>
D-Cord & Plug	<b>PAGE 6</b>
E-Power Supply	<b>PAGE 6</b>
F-Placing Equipment On Top Of Unit	<b>PAGE 6</b>
<b>4. OPERATION</b>	
A-Refrigerators	<b>PAGE 7</b>
<b>5. CARE &amp; MAINTENANCE</b>	
A-Cleaning The Condenser/Filter	<b>PAGE 7</b>
B-Replacing The Gaskets	<b>PAGE 8</b>
C-Cleaning The Cabinet Surface	<b>PAGE 8</b>
<b>6. DRAWERS</b>	
A-Removing The Drawers And Frame Module	<b>PAGE 9</b>
<b>7. MICROPROCESSOR CONTROL</b>	
A-Control Features	<b>PAGE 10</b>
B-Alarm Explanations	<b>PAGE 11</b>
C-Control Panel Diagram	<b>PAGE 12</b>
D-Notes To The User	<b>PAGE 13</b>
E-Enter The Service	<b>PAGE 13</b>
F-Service Parameters	<b>PAGE 14</b>
G-Adjusting Thermostat Set Point High	<b>PAGE 14</b>
H-Adjusting Thermostat Set Point Low	<b>PAGE 15</b>
I-Changing The Temperature Scale	<b>PAGE 16</b>
J-Setting The 24-Hour Clock	<b>PAGE 16</b>
K-Setting The Date	<b>PAGE 18</b>
L-Setting Daylight Savings Time	<b>PAGE 19</b>
M-Starting A Manual Defrost	<b>PAGE 20</b>
N-Setting Defrost Lockouts	<b>PAGE 21</b>
O-Adjusting The Drawer Perimeter Heaters	<b>PAGE 23</b>
P-Adjusting The Room Temperature Offset	<b>PAGE 24</b>
Q-Setting The Audible Alarm Style	<b>PAGE 25</b>
R-Viewing Sensor Temperatures	<b>PAGE 26</b>
<b>8. WIRING DIAGRAM</b>	<b>PAGE 27</b>
<b>9. TROUBLE SHOOTING GUIDE</b>	<b>PAGE 28</b>
<b>10. SERVICE ASSISTANCE</b>	
A-Service Information	<b>PAGE 29</b>
B-Spare Parts Information	<b>PAGE 29</b>
<b>11. WARRANTIES</b>	<b>PAGE 30</b>
<b>12. SERVICE PARTS LIST</b>	<b>PAGE 31</b>

# 1. THE SERIAL TAG

The serial tag is a permanently affixed label on which is recorded vital electrical and refrigeration data about your Kairak product, as well as the model and serial number. This tag is located in the right interior compartment on all standard Equipment Stand models.

## READING THE SERIAL TAG

- **Serial** = The permanent ID# of your Kairak unit
- **Model** = The model # of your Kairak unit
- **Volts** = Voltage
- **Hz** = Cycle
- **PH** = Phase
- **Total Current** = Maximum amp draw
- **Minimum Circuit** = Minimum circuit ampacity
- **Lights** = Light wattage
- **Heaters** = Heater amperage (Hot Food units only)
- **Refrigerant** = Refrigerant type used
- **Design Pressure** = High & low side operating pressures and refrigerant charge
- **Agency Labels** = Designates agency listings

<b>SERIAL</b>		<b>MODEL</b>	
<b>VOLTS</b>	<b>HZ</b>	<b>PH</b>	
<b>TOTAL CURRENT</b>		<b>AMPS</b>	
<b>MINIMUM CIRCUIT</b>		<b>AMPS</b>	
<b>MAXIMUM OVERCURRENT PROTECTION</b>			<b>AMPS</b>
<b>LIGHTS</b>		<b>WATTS</b>	
<b>HEATERS</b>		<b>AMPS</b>	
<b>REFRIGERANT</b>		<b>TYPE</b>	<b>OZ</b>
<b>DESIGN PRESSURE</b>		<b>HIGH</b>	<b>LOW</b>
<b>REFRIGERANT</b>		<b>TYPE</b>	<b>OZ</b>
<b>DESIGN PRESSURE</b>		<b>HIGH</b>	<b>LOW</b>



## 2. RECEIPT INSPECTION

All Kairak products are factory tested for performance and are free from defects when shipped. The utmost care has been taken in crating this product to protect against damage in transit.

You should carefully inspect your Kairak unit for damage during delivery. If damage is detected, you should save all the crating materials and make note on the carrier's Bill Of Lading describing the damage. A freight claim should be filed immediately. If damage is subsequently noted during or immediately after installation, contact the respective carrier and file a freight claim. There is a fifteen (15) day limit to file freight damage with the carrier. Under no condition may a damaged unit be returned to Kairak without first obtaining written permission (return authorization). You may contact Kairak customer care at (714) 870-8661 or Toll-Free (800) 833-1106 to request a return.

## 3. INSTALLATION

### 3A - LOCATION:

Unit must be placed on leveled floor for proper usage.

### 3B - PACKAGING:

Your Kairak unit is shipped from the factory packaged with stretch wrap material.

Most exterior stainless steel surfaces have a protective blue vinyl covering to prevent scratching during manufacturing, shipping and installation. After the unit is installed in place of application peel, remove and discard the covering from all surfaces.

The equipment stands are shipped on a skid that is designed to allow a unit to be slid off the skid onto the factory installed casters. When a unit is being removed from the skid two or more runners will act as slides and will remain with the unit while it is being removed. These runners prevent damage to the machine when it drops off the skid to the floor. The runners are retained by the bolts located in the top holes of the mounting brackets **(B)**.

To unload the machine, remove the exterior packaging. Next remove the retaining brackets. This bracket is held in place by two bolts into the skid and two screws into the caster channel. There are two of these brackets per skid segment. Next remove the remaining bolts in the lower holes of the mounting brackets **(A)** leaving the bolts in the upper holes **(B)** in place. Next push the machine off the skid keeping the length of the machine parallel to the skid's 4x4 pieces. On longer machines this may require two or more individuals. When the machine is on its casters the 2x4 runners can be removed by removing the bolts from the top holes **(B)** in the mounting brackets. The mounting brackets are removed from the caster channel by twisting the bracket 90 degrees.

### 3. INSTALLATION (CONTINUED)

#### RETAINING BRACKET

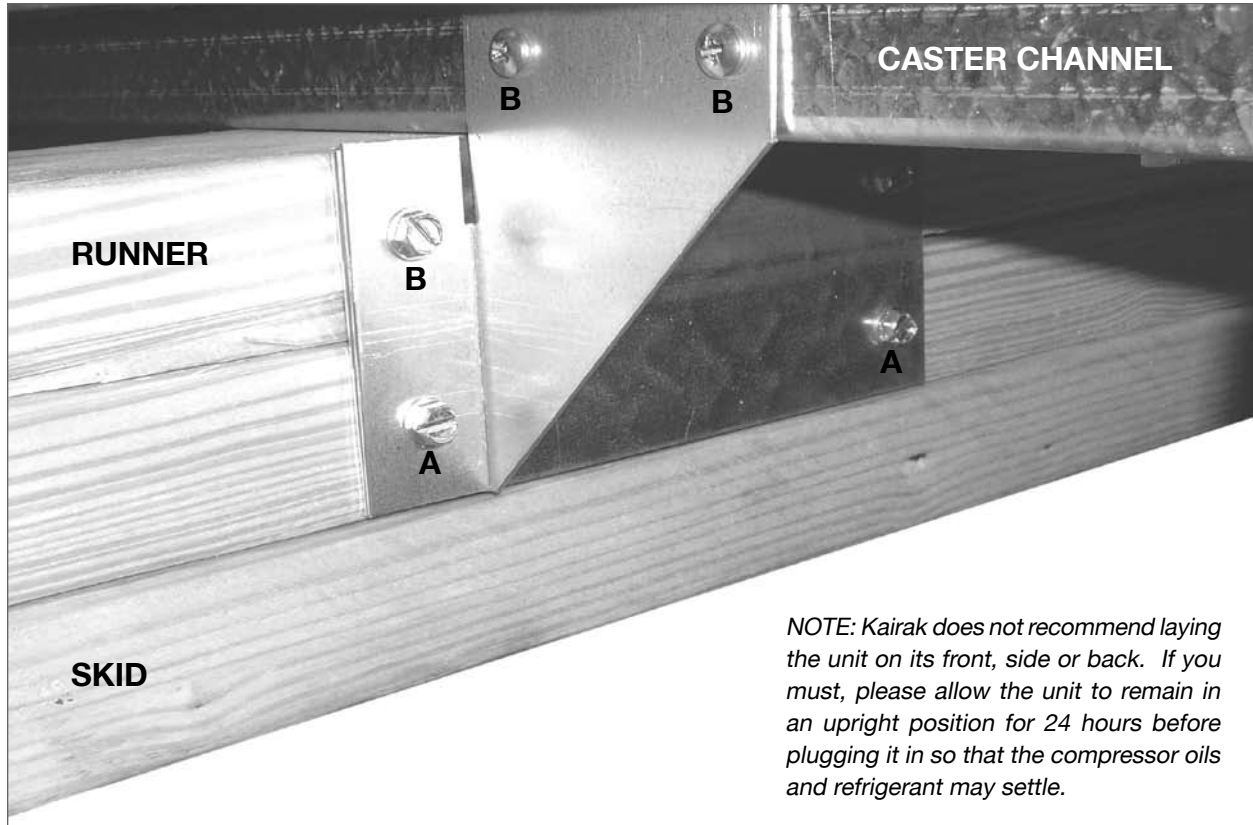

FIG. 1

#### 3C - ADJUSTING THE CASTERS:

To adjust the caster loosen the two bolts and move caster to desired location, spacing between casters not to exceed 48 inches. Casters on each end of the unit can not exceed 8 inches from the end of the cabinet.

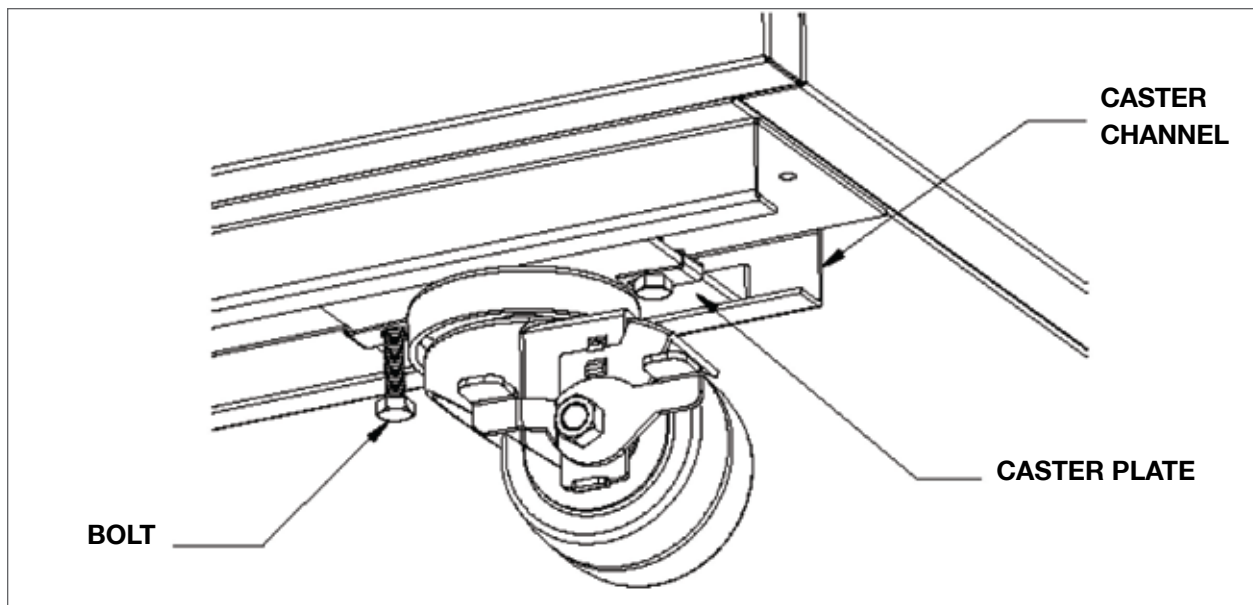

FIG. 2

## 3. INSTALLATION (CONTINUED)

### 3D - CORD & PLUG:

All self-contained models are shipped standard with a NEMA 5-15P plug and 9 foot cord and spring retainer attached at the rear of the cabinet. Select only a dedicated electrical outlet for power source.

*NOTE: Do not under any circumstances, cut or remove the round grounding prong from the plug, or use an extension cord.*

### 3E - POWER SUPPLY:

The supply voltage should be checked prior to connection to be certain that proper voltage for the cabinet wiring is available (refer to the serial tag to determine correct unit voltage). Make connections in accordance with local electrical codes. Use qualified electricians.

Use of a separate, dedicated circuit is required. Size wiring to handle indicated load and provide necessary overcurrent protector in circuit (see amperage requirements on the unit's serial tag).

### 3F - PLACING EQUIPMENT ON TOP OF UNIT:

Equipment may be placed on top of your Kairak equipment stand. A stainless steel worktop, provided standard is required on cabinets being used to support equipment weighing in excess of 100 lbs. or producing heat in excess of 140°F to the top surface. Refer to below chart to determine Maximum Top Load Capacity for your unit.

MODEL	MAX TOP LOAD CAPACITY LBS.
KE036	625
KE048	625
KE060	1200
KE065	1200
KE072	1200
KE084	1500
KE096	1500
KE110	1500
KE125	2000
KE139	2000

## 4. OPERATION

### 4A - REFRIGERATORS:

Refrigerators do not require manual defrosting. During normal operation, a refrigerator continuously circulates above freezing cabinet air through the coil. A compressor “OFF” cycle occurs every 2 1/2 Hours for 20 minutes to melt any frost which may accumulate on the coil during the compressor “ON” cycle. The control will read “dEF” and the green water drop will be illuminated. With standard holding refrigerators, high relative humidity is also maintained to prevent dehydration of stored product.

### MICROPROCESSOR CONTROL



FIG. 3

## 5. CARE & MAINTENANCE

### 5A - CLEANING THE CONDENSER/FILTER:

The most important thing you can do to insure a long, reliable service life for your Kairak is to regularly clean the condenser coil and or filter if provided.

The microprocessor control will notify you through a “CLN-FIL” message when the condensing temperature of the refrigerator reaches 140 degrees F or greater. If the condensing temperature reaches 160 degrees F the compressor will automatically turn off . When the temperature drops below 140 degrees F the compressor will restart and when the temperature drops below 120 degrees F the alarm will reset.

**WARNING:** DISCONNECT ELECTRICAL POWER SUPPLY BEFORE CLEANING ANY PARTS OF THE UNIT.

To clean the condenser/filter, first disconnect electrical power to the cabinet and remove the front louver assembly. To do so, place hands under the louver panel and pull out and up to get louver panel off bracket of the unit. See diagram below.

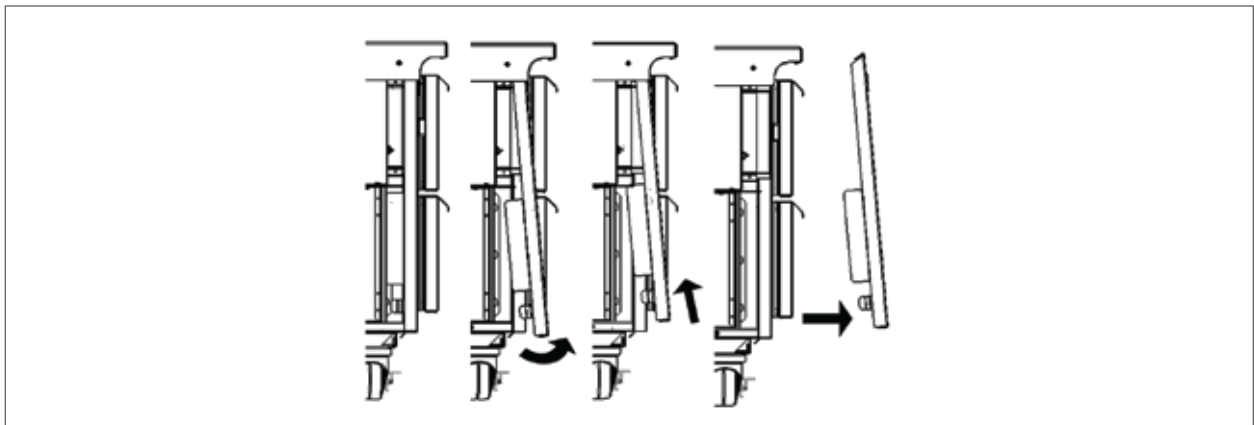

FIG. 4

## 5. CARE & MAINTENANCE (CONTINUED)

### 5A - CLEANING THE CONDENSER/FILTER (CONTINUED):

Proceed to vacuum or brush any dirt, lint or dust from the finned condenser coil/filter, the compressor and other cooling system parts. If significant dirt is clogging the condenser fins or filter, use compressed air to blow this clear.

To replace the louver assembly reverse the process.

### 5B - REPLACING THE GASKETS:

To remove the gasket to be replaced, grasp it firmly by one corner and pull it out. Before attempting to install a new gasket, both the unit and the gasket itself must be at room temperature. Insert the four corners first by using a rubber mallet (or hammer with a block of wood). After the corners are properly inserted, work your way towards the center from both ends by gently hitting with a mallet until the gasket is completely seated in place (see figure 5 for proper gasket placement).

*NOTE: The gasket may appear too large, but if it is installed as indicated above it will slip into place.*

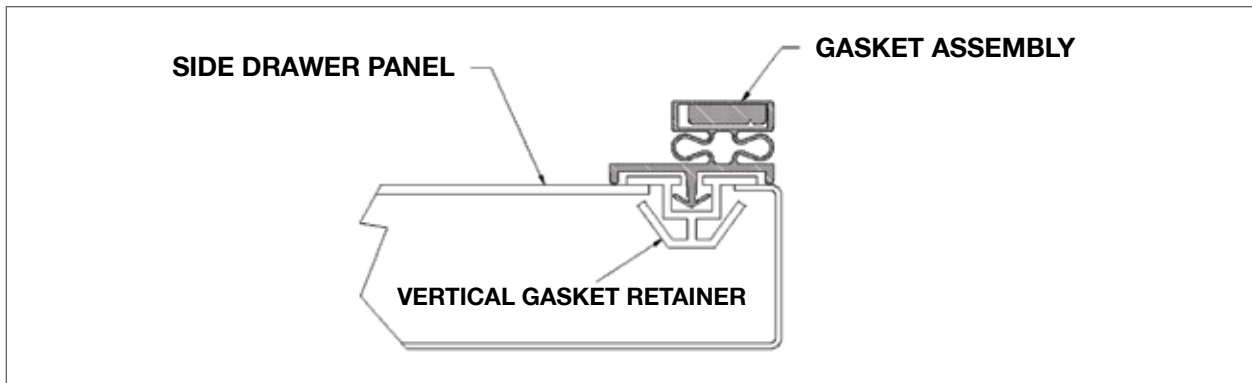

FIG. 5

### 5C - CLEANING THE CABINET SURFACES:

**WARNING:** DISCONNECT ELECTRICAL POWER SUPPLY BEFORE CLEANING ANY PARTS OF THE UNIT.

Exterior stainless steel should be cleaned with warm water, mild soap and a soft cloth. Apply with a dampened cloth and wipe in the direction of the metal grain.

Avoid the use of strong detergents and gritty, abrasive cleaners as they may tend to mar and scratch the surface. Do NOT use cleansers containing chlorine, such as bleach, this may promote corrosion of the stainless steel.

Care should also be taken to avoid splashing the unit with water, containing chlorinated cleansers, when mopping the floor around the unit.

For stubborn odor or spills, use baking soda and water (mixed to a 1 tbsp baking soda to 1 pint water ratio).

A stainless steel polish is recommended for shining of unit.

## 6. DRAWERS

### 6A - REMOVING THE DRAWERS AND FRAME MODULE:

Remove the drawer (s) from the drawer frame by lifting up on the drawer and pull out. Once the drawer(s) have been removed, the drawer frame module can also be removed by loosening the black front and back clamping knobs (2 of each) located on the cross rail locks and liner locks. Slide the front cross rail locks towards the center of the drawer frame module and allow the liner locks to drop down from the top of the liner. Pull the door frame module forward, tip forward and pull out. The entire frame assembly is now free to slide out of the cabinet.

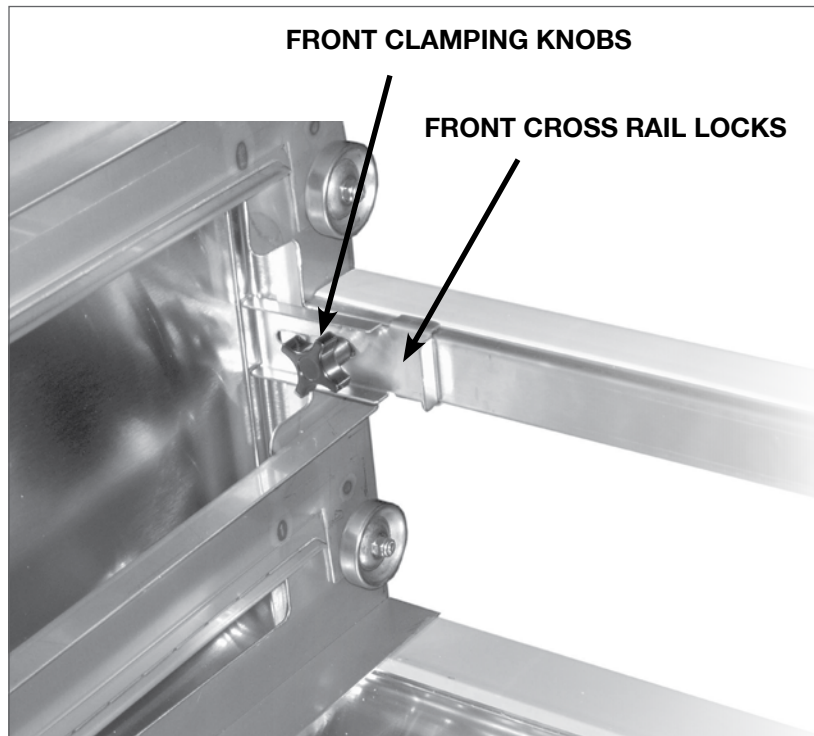

FIG. 6

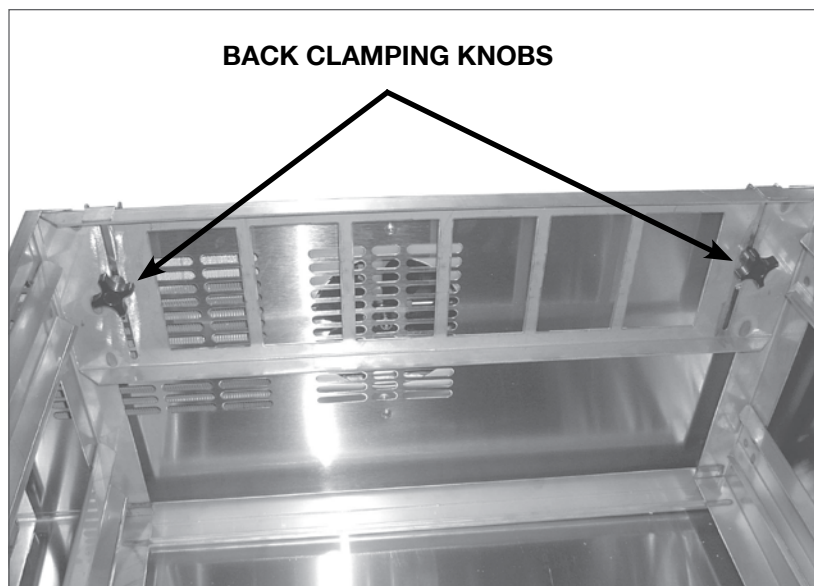

FIG. 7

# 7. MICROPROCESSOR CONTROL

Your new refrigerator cabinet is equipped with a state-of-the-art microprocessor control, which precisely regulates operation and provides alarms when problems occur. It is supplied from the factory completely ready for use and requires no adjustments, but without the audible alarms activated. See pages 10 thru 26 for more information.

## MICROPROCESSOR CONTROL

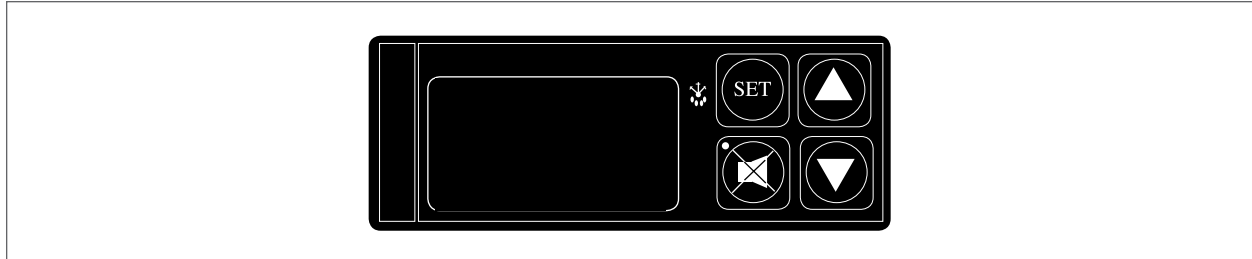

FIG. 8

### 7A - CONTROL FEATURES:

#### 1 - INTERNAL TIME CLOCK

- Eliminates external defrost time clock.
- Defrost cycle can be quickly adjusted to suit individual location and use.
- Must be set at power-up. (See page 17, "Setting the 24-Hour Clock")
- Will automatically update for Daylight Savings Time.

#### 2 - WATER RESISTANT HOUSING

The face of the control is water resistant to provide for protection during cleaning.

#### 3 - PARAMETER/SERVICE LEVELS

- See "Customer / Service Parameters" on Page 14.

#### 4 - DEFROST LOCKOUTS (See "Setting Defrost Lockouts" on page 21)

Customers can set up to 4 different defrost lockout periods. The lockout prevents the unit from going into a defrost cycle during peak kitchen use.

*Note: The 24-hour clock must be set for this feature to operate correctly.*

#### 5 - COMMUNICATION ABILITY

A NAFEM Data Protocol (NDP) compliant RS-485 serial communications port is available to interface with data collection software (by others). All microprocessor control equipped models are capable of communicating within a NAFEM Data Protocol network if provided with an optional Gateway Hub (available from Kairak). The actual communications software is available from a number of third party software vendors.

#### 6 - ANTI-CONDENSATE DOOR PERIMETER HEATER CONTROL

The "No-Sweat" feature is an energy savings system that allows the customer to adjust the percent of time for the drawer heater to be "On" as needed for the prevailing ambient conditions (from 0 - 100% of the time each day). It is used to prevent condensation from forming around the perimeter of the drawers. The factory default setting is 100%. Adjust this set point down to a point just before condensation forms to save energy.

# 7. MICROPROCESSOR CONTROL (CONT.)

## 7A - CONTROL FEATURES (CONTINUED):

### 7 - ALARMS (See the following pages for explanations)

- High Cabinet Air Temperature
- Low Cabinet Air Temperature
- Loss Of Power
- Sensor Failure
- Clean Condenser

### 8 - DISPLAY FEATURES

- 3-Digit LED Display
- Defrost in Progress Icon
- Fahrenheit or Celsius Temperature Scale In Use

## 7B - ALARM EXPLANATIONS:

*\*NOTE: Explanation of alarms assume the audible alarm style is set at a 3-second burst or a continuous audible alarm. References to the audible alarm do not apply if the audible alarm style is set to OFF (Refer to page 25 for setting the audible alarm style).*



### HIGH CABINET AIR TEMPERATURE:

The audible alarm will sound and the display will read HI CAB when the temperature inside the cabinet rises above a pre-programmed limit. The limit is determined by the type of unit being operated (i.e.: refrigerator/freezer). To turn off the audible alarm, press the alarm cancel button. The visual alarm text will continue to display until the cabinet air temperature falls below the limit. If the temperature does not fall below the limit within 5 minutes, the audible alarm\* will sound again and an additional Call Service message will display.

#### POSSIBLE CAUSES:

- Drawers open for extended periods of time.
- Large amounts of hot product placed inside the cabinet.
- Condenser coil dirty.

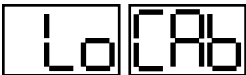

### LOW CABINET AIR TEMPERATURE:

The audible alarm will sound and the display will read Lo Cab when the temperature inside the cabinet falls below a pre-programmed limit. The limit is determined by the type of unit being operated (i.e.: refrigerator/freezer). To turn off the audible alarm, press the alarm cancel button. The visual alarm text will continue to display until the cabinet air temperature rises above the limit. If the temperature does not rise above the limit within 5 minutes, the audible alarm will sound again and an additional Call Service message will display.

#### POSSIBLE CAUSES:

- No product in unit.
- Failed sensors.

# 7. MICROPROCESSOR CONTROL (CONT.)

## 7B - ALARM EXPLANATIONS (CONTINUED):

### LOSS OF POWER:

The audible alarm will sound and the display will read ELE LOS, when the unit regains power after an outage. To turn off the audible alarm and/or clear the visual text, press the alarm cancel button.

### CONDENSER CLEAN:

The audible alarm will sound and the display will read Clean Filter when discharge temperatures exceeds 140 degrees. As the load on the condenser decreases, the alarm will turn off by itself. As the temperature on the condenser continue to rise, the audible alarm will return until the problem has been eliminated.

### SENSOR FAILURES:

The audible alarm will sound and the display will read CAB SEN, COL SEN or DIS SEN when that particular sensor has failed to operate. To turn off the audible alarm, press the alarm cancel function of the sensor, the audible alarm will sound again in either 5 minutes or 24 hours.

## 7C - CONTROL PANEL DIAGRAM:

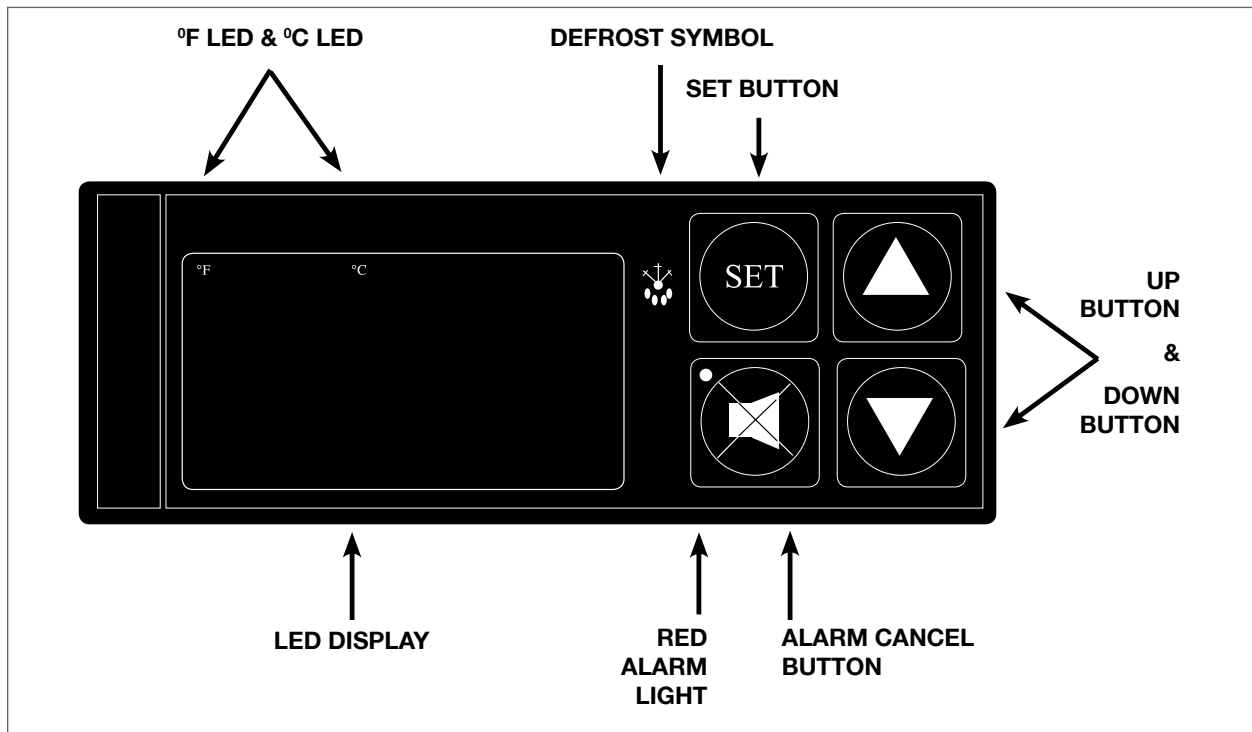

FIG. 9



# 7. MICROPROCESSOR CONTROL (CONT.)

## 7D - NOTES TO THE USER:

You only have 20-30 seconds between button pushes. If you take longer than 30 seconds, the controller will revert back to displaying the cabinet temperature. If you enter the wrong security code, the controller will revert back to displaying the cabinet temperature. You can exit the parameters at any time by pressing the alarm cancel button or by waiting 20-30 seconds.

## 7E - ENTER THE SERVICE ACCESS:

Use the security code 0, A, 1  and the following instructions:

Press the set button.  The display will read  Service Access.

Press the set button. 

The display will show three zeros with the left zero flashing.   
↑

Press the set button. 

The display will show three zeros with the center zero flashing.   
↑

Press the down arrow key  to sequence through F, E, d, C, b, A, 9, 8, 7,...etc.



When you reach A press set. 

The display will show zero, A, zero with the right zero flashing.   
↑

Press the up arrow key  to sequence through 1, 2, 3, 4, 5, 6, 7, 8, 9, A, b,...etc.

When you reach 1 press set. 

The display will read  Thermostat Set Point High.

Press  to view and  again to exit.

You are now in the SERVICE PARAMETERS.

## 7. MICROPROCESSOR CONTROL (CONT.)

### 7F - SERVICE PARAMETERS:

Listed below are the available parameters in the order they appear, using the down arrow key on the controller. You can use either the up or down arrow keys to scroll through the options.



Thermostat Set Point High



Defrost Lockout 3



Thermostat Set Point Low



Defrost Lockout 4



Temperature Scale



Point Compensation Factor



Time (24-hour clock)



Room Temperature Offset



Date (month-day-year)



Audible Alarm Style



Daylight Savings



Cabinet Air Sensor Temp



Start Manual Defrost



Evaporator Coil Sensor



Defrost Lockout 1



Discharge Line Sensor



Defrost Lockout 2



### 7G - ADJUSTING THERMOSTAT SET POINT HIGH:



This parameter sets the high point of the desired cabinet temperature range. Typically, freezers will range from -3° F to 0° F (-19° C to -18° C) and refrigerators will range from 36° F to 40° F (2° C to 4° C) for this parameter setting. This parameter is preset at the factory and does not have to be adjusted unless the customer chooses to do so. *Note: Set Point Low and Set Point High cannot be set to the same temperature. There must be at least 1-2 degree difference between the two settings.*

# 7. MICROPROCESSOR CONTROL (CONT.)

## 7G - ADJUSTING THERMOSTAT SET POINT HIGH (CONTINUED):



Follow the instructions to enter the customer access code on page 13.

When the control display reads  Thermostat Set Point High. Press the set button. 

Use the arrow keys   to adjust the temperature to your desired setting.

When the display shows the temperature you want press the set button. 

The display will then read  Thermostat Set Point High.

You can use the up or down arrow keys to scroll to the next parameter  



Or press the alarm cancel button to exit 



## 7H - ADJUSTING THERMOSTAT SET POINT LOW:

This parameter sets the low point of the desired cabinet temperature range. Typically, freezers will range from -6° F to -4° F (-21° C to -20° C) and refrigerators will range from 32° F to 34° F ( 0° C to 1° C) for this parameter setting. This parameter is preset at the factory and does not have to be adjusted unless the customer chooses to do so. *Note: Set Point Low and Set Point High cannot be set to the same temperature. There will be at least 1-2 degree difference between the two settings.*

Follow the instructions to enter the service access code on page 13.



When the control displays  Thermostat Set High, press the down arrow key  until the

Control display reads  Thermostat Set Point Low. Press the set button. 

Use the arrow keys   to adjust the temperature to your desired setting. 

When the display shows the temperature you want press the set button.

The display will then read  Thermostat Set Point Low.

You can use the up or down arrow keys to scroll to the next parameter  



Or press the alarm cancel button to exit 



# 7. MICROPROCESSOR CONTROL (CONT.)

## 7I - CHANGING THE TEMPERATURE SCALE:

The temperature scale determines if the temperature displayed will be in degrees Fahrenheit or degrees Celsius.

Follow the instructions to enter the customer access code on page 13.

When the control displays  Thermostat Set High, press the down arrow key  until the

Control display reads  Temperature Scale. Press the set button. 

The display will start with the current setting either  for degrees Fahrenheit  
↑

Or  for degrees Celsius.

Use the arrow keys   to toggle between the options.

When the display shows the scale you want press the set button. 

The display will then read  Temperature Scale.

You can use the up or down arrow keys   to scroll to the next parameter

Or press the alarm cancel button to exit 

## 7J - SETTING THE 24-HOUR CLOCK:

The internal time clock must be set in order for the data storage memory to correctly log events and to allow any defrost lockout to occur at the correct time of day. If the clock is not set, the control assumes the time is 12 am at the time power is supplied to the unit. The hours on the 24-hour time clock are read the following way:



H01 = 1:00 a.m.	H07 = 7:00 a.m.	H13 = 1:00 p.m.	H19 = 7:00 p.m.
H02 = 2:00 a.m.	H08 = 8:00 a.m.	H14 = 2:00 p.m.	H20 = 8:00 p.m.
H03 = 3:00 a.m.	H09 = 9:00 a.m.	H15 = 3:00 p.m.	H21 = 9:00 p.m.
H04 = 4:00 a.m.	H10 = 10:00 a.m.	H16 = 4:00 p.m.	H22 = 10:00 p.m.
H05 = 5:00 a.m.	H11 = 11:00 a.m.	H17 = 5:00 p.m.	H23 = 11:00 p.m.
H06 = 6:00 a.m.	H12 = 12:00 p.m.	H18 = 6:00 p.m.	H24 = 12:00 a.m.

## 7. MICROPROCESSOR CONTROL (CONT.)

### 7J - SETTING THE 24-HOUR CLOCK (CONTINUED):

Follow the instructions to enter the customer access code on page 13.

When the control displays  Thermostat Set High,

Press the down arrow key  until the control display reads  Clock.



Press the set button. 

The display will show  Hours. The right two numbers will be flashing.

Use the arrow keys   to set the hour.

When the correct hour is displayed, press the set button. 

The display will show  Minutes. The right two numbers will be flashing.

Use the arrow keys to set the minutes.  

When the correct minutes are displayed, press the set button. 

The display will then read  Clock.

You can use the up or down arrow keys   to scroll to the next parameter

Or press the alarm cancel button to exit. 

# 7. MICROPROCESSOR CONTROL (CONT.)

## 7K - SETTING THE DATE:

The date must be set in order for the data storage memory to correctly log events.

Follow the instructions to enter the service access code on page 8.

When the control displays  Thermostat Set Point High,

Press the down arrow key 

Until the control display reads  Date. Press the set button. 

The display will show  (year). The right two numbers will be flashing.

Press the arrow keys   to set the year.

When the correct year is displayed, press the set button. 

The display will show  (month). The right two numbers will be flashing.

Use the arrow keys   to set the month.

When the correct month is displayed, press the set button. 

The display will show  (day). The right two numbers will be flashing.

Press the arrow keys   to set the day.

When the correct day is displayed, press the set button. 

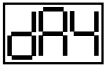
The display will then read  Date.

You can use the up or down arrow keys   to scroll to the next parameter,

Or press the alarm cancel button to exit. 

## 7. MICROPROCESSOR CONTROL (CONT.)

### 7L - SETTING DAYLIGHT SAVINGS TIME:

This parameter is preset at the factory to automatically adjust the 24-hour clock for Daylight Savings Time.

Follow the instructions to enter the customer access code on page 13.

When the control displays  Thermostat Set Point High,

Press the down arrow key 



Until the display reads  Daylight Savings Time.

Press the set button. 

The display will show  Daylight Savings Time,

(Yes, automatically adjust for Daylight Savings Time).

For "YES" press the set button, 

For "NO" press the up or down arrow key.  

The display will read  Daylight Savings Time (no).

Press the set button. 

The display will read  Daylight Savings Time.

You can use the up or down arrow keys   to scroll to the next parameter

Or press the alarm cancel button to exit. 

# 7. MICROPROCESSOR CONTROL (CONT.)

## 7M - STARTING A MANUAL DEFROST CYCLE:

This parameter allows a service technician to start a defrost cycle at any time. This parameter will override any lockout settings.

Follow the instructions to enter the customer access code on page 13.

When the control displays  Thermostat Set High,

Press the down arrow key 

Until the control display reads  Start Manual Defrost.

Press the set button. 

The display will show 

Press either arrow key   (YES)

The display will show 

Press the set button. 

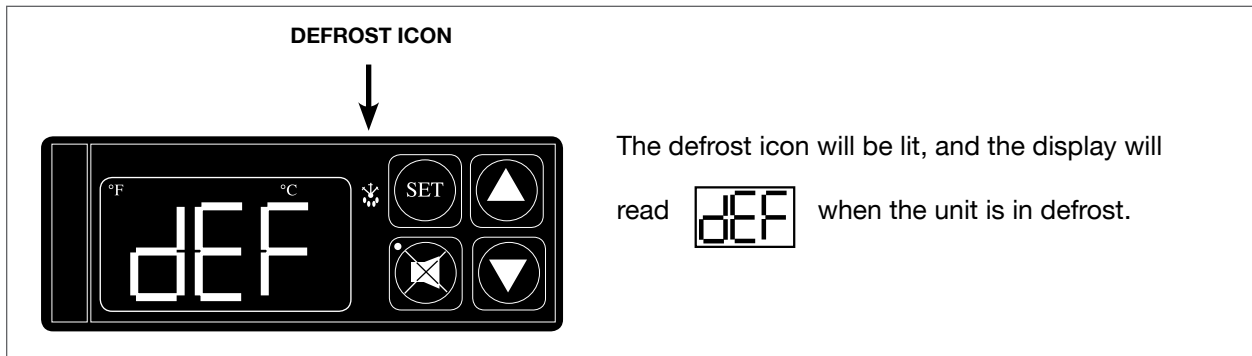



FIG. 10

NOTE: Kairak refrigerator units also have an off-cycle defrost, at which time the control will read 

This defrost is temperature terminated and can last from 3 - 20 minutes (dEF will be displayed for 20 - 37 minutes time).

# 7. MICROPROCESSOR CONTROL (CONT.)

## 7N - SETTING THE DEFROST LOCKOUTS:





The defrost lockout parameters allow the customer to prevent the unit from going into a defrost cycle for two hours during a set time frame. Customers can set up to four defrost lockout parameters. They are all programmed the same way. The parameters will be set for the time the lockout is to start. The controller automatically calculates 2 hours from that setting. The options are similar to the 24-hour clock settings and are in 30-minute increments. Each of the lockout parameters covers 6 hours of the 24-hour clock.

*Note: The 24-hour clock must be set for this feature to operate at the correct time of day.*

See "Setting the 24-Hour Clock" on page 16.

### SAMPLE:



			
OFF	OFF	OFF	OFF
020 = 2:00 a.m.	080 = 8:00 a.m.	140 = 2:00 p.m.	200 = 8:00 p.m.
023 = 2:30 a.m.	083 = 8:30 a.m.	143 = 2:30 p.m.	203 = 8:30 p.m.
030 = 3:00 a.m.	090 = 9:00 a.m.	150 = 3:00 p.m.	210 = 9:00 p.m.
033 = 3:30 a.m.	093 = 9:30 a.m.	153 = 3:30 p.m.	213 = 9:30 p.m.
040 = 4:00 a.m.	100 = 10:00 a.m.	160 = 4:00 p.m.	220 = 10:00 p.m.
043 = 4:30 a.m.	103 = 10:30 a.m.	163 = 4:30 p.m.	223 = 10:30 p.m.
050 = 5:00 a.m.	110 = 11:00 a.m.	170 = 5:00 p.m.	230 = 11:00 p.m.
053 = 5:30 a.m.	113 = 11:30 a.m.	173 = 5:30 p.m.	233 = 11:30 p.m.
060 = 6:00 a.m.	120 = 12:00 p.m.	180 = 6:00 p.m.	240* = 12:00 a.m.
063 = 6:30 a.m.	123 = 12:30 p.m.	183 = 6:30 p.m.	243* = 12:30 a.m.
070 = 7:00 a.m.	130 = 1:00 p.m.	190 = 7:00 p.m.	010 = 1:00 a.m.
073 = 7:30 a.m.	133 = 1:30 p.m.	193 = 7:30 p.m.	013 = 1:30 a.m.
080 = 8:00 a.m.	140 = 2:00 p.m.	200 = 8:00 p.m.	020 = 2:00 a.m.

\* Denotes not available.

A lockout can not be programmed to start at 12:00 a.m. or 12:30 a.m. due to conflicts with other internal programs. The defrost lockouts can not be programmed to run back-to-back. For example, if dL1 is set to 080, then a defrost cycle would be locked out from 8:00 a.m. to 10:00 a.m. Because of the dL1 setting the dL2 parameter would not let the user choose a lockout start time before 10:30 a.m. All lockouts are preset at the factory to OFF.

# 7. MICROPROCESSOR CONTROL (CONT.)

## 7N - SETTING THE DEFROST LOCKOUTS (CONTINUED):

Follow the instructions to enter the customer access code on page 13.

When the control displays  Thermostat Set High,

Press the down arrow key 

Until the control display reads     or

Press the set button 

The display will show  Off.

Press the arrow keys   to set the start time.

When the correct time is displayed, press the set button. 

The display will then read     or

You can use the up or down arrow keys   to scroll to the next parameter

Or press the alarm cancel button to exit. 

# 7. MICROPROCESSOR CONTROL (CONT.)

## 70 - ADJUSTING THE DRAWER PERIMETER HEATERS:

This parameter allows the customer to turn ON and OFF the anti-condensate drawer perimeter heaters. This parameter is set to the highest setting (100) at the factory so that the drawer heaters stay on continuously. If you choose to have the drawer heaters cycle on and off, lower this parameter to approximately 30. If condensation forms around the drawers, increase the parameter until condensation stops. The exact setting will vary depending on ambient conditions.



Follow the instructions to enter the customer access code on page 13.

When the control displays  Thermostat Set High,

Press the down arrow key 

Until the control display reads  DewPoint Compensation Factor.

Press the set button. 

Press the arrow keys   to adjust the factor to your desired setting.

When the display shows the factor you want, press the set button. 

The display will then read  DewPoint Compensation Factor.

You can use the up or down arrow keys   to scroll to the next parameter

Or press the alarm cancel button to exit. 

# 7. MICROPROCESSOR CONTROL (CONT.)

## 7P - ADJUSTING THE ROOM TEMPERATURE OFFSET:

The room temperature offset parameter allows a service technician or end user the ability to have the display show a temperature that is within three degrees of the actual temperature being read by the cabinet air sensor. This allows for continuity of reading between different temperature reading devices, (i.e.: thermistor vs. thermocouple vs. handheld thermometer.) This parameter is preset at the factory to “-2.5°F”.



Follow the instructions to enter the customer access code on page 13.

When the control displays  Thermostat Set High,

press the down arrow key 

Until the control display reads  Room Temperature Offset.

Press the set button. 

Use the arrow keys   to adjust the offset to your desired setting.

When the display shows the offset you want press the set button. 

The display will then read  Room Temperature Offset.

You can use the up or down arrow keys   to scroll to the next parameter

Or press the alarm cancel button to exit. 

## 7. MICROPROCESSOR CONTROL (CONT.)

### 7Q - SETTING THE AUDIBLE ALARM STYLE:



These parameters will allow the customer to turn on/off the audible alarm feature on the microprocessor control. The audible alarm is preset from the factory to OFF. The customer can choose between an audible alarm that sounds for 3 seconds then automatically turns off, or a continuous audible alarm that must be manually acknowledged. Regardless of this feature's setting, visual alarm text will display when conditions warrant.

Follow the instructions to enter the customer access code on page 13.

When the control displays  Thermostat Set Point High,

Press the up arrow key 

Until the display reads  Audible Alarm Style.

Press the set button  The display will read  OFF.

Use the arrow keys   to scroll between  for the 3-Second

Audible Alarm Burst or  for Continuous Audible Alarm.

When the display shows your choice of style, press the set button. 

The display will then read  thermostat Set Point High.

You can use the up or down arrow keys   to scroll to the next parameter

Or press the alarm cancel button to exit. 

## 7. MICROPROCESSOR CONTROL (CONT.)

### 7R - VIEWING SENSOR TEMPERATURES:

These parameters allow a service technician or customer to view the temperature of all sensors within the unit. The temperatures cannot be adjusted.

Follow the instructions to enter the customer access code on page 13.

When the control displays  Thermostat Set Point High,

Press the up arrow key 

Until the display reads  Evaporator Coil Sensor

Or Discharge Line Sensor  or press the set button.

The display will read the temperature of the designated sensor.

You can use the up or down arrow keys   to scroll to the next parameter

Or press the alarm cancel button to exit. 

# 8. WIRING DIAGRAM

Note: Refer to the wiring diagram below for any service work performed by a qualified technician.

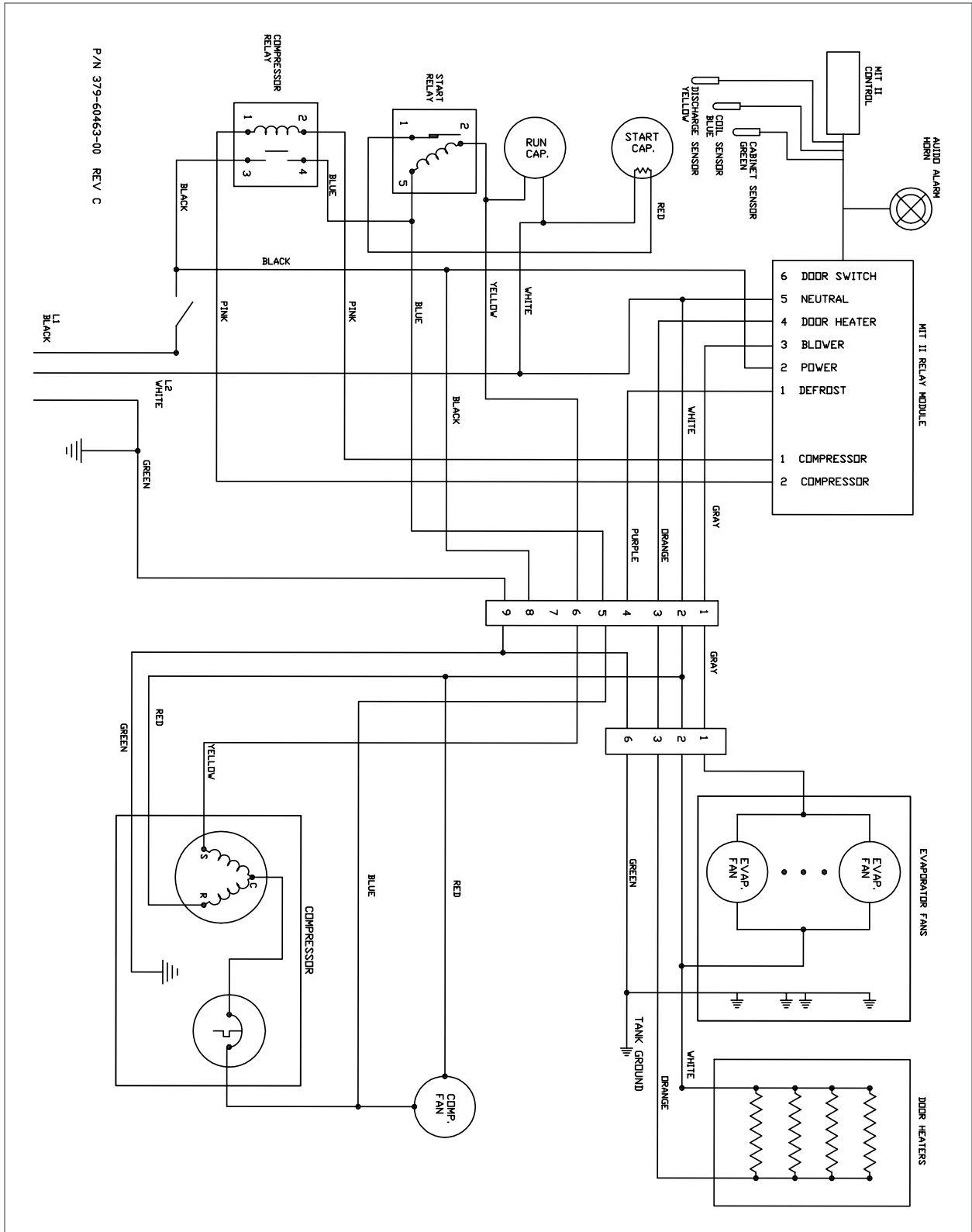

## 9. TROUBLESHOOTING GUIDE

PROBLEM	POSSIBLE SOLUTION
1. Condensing unit fails to start.	a. Check if cord & plug has been disconnected.
2. Condensing unit operates for prolonged periods or continuously.	a. Are drawers closing properly? b. Dirty condenser or filter. Clean properly. c. Evaporator coils iced. Needs to defrost. See instructions for setting a manual defrost cycle p. 13.
3. Food Compartment is too warm.	a. Check drawer (s) and gasket (s) for proper seal. b. Check if a large quantity of warm food was recently added or the door was kept open for a long period of time. c. Microprocessor control setting is too high. Readjust per instructions on p. 9 and 10.
4. Food Compartment is too cold.	a. Check if a large quantity of very cold or frozen food has recently been added. Allow adequate time for the cabinet to recover its normal operating temperature. b. Adjust the microprocessor control to warmer setting. Readjust per instruction on p. 9 and 10.
5. Condensation on exterior surface.	a. Check drawer (s) alignment and gaskets for proper seal. b. Condensation on the exterior surface of the unit is perfectly normal during periods of high humidity. c. Check perimeter heat setting and increase setting if <100 (see section VII).
6. Compressor hums & does not start.	a. Call for service.

# 10. SERVICE ASSISTANCE

## 10A - SERVICE INFORMATION:

Before calling for service, please check the following:

- Is the electrical cord plugged in?
- Is the fuse OK or circuit breaker on?
- Clean condenser coil
- Is the power switch on?

If after checking the above items and the unit is still not operating properly, please contact Kairak for an authorized service agent.

Kairak  
500 S. State College Blvd.  
Fullerton, CA 92831  
Phone: (714) 870-8661 Toll-Free (800) 833-1106  
Fax: (714) 870-6473

Kairak reserves the right to change specifications or discontinue models without notice.

## 10B - SPARE PARTS INFORMATION:

To purchase replacement parts or to speak to service support for Kairak units please contact us:

Phone: (714) 870-8661  
Toll-Free: (800) 833-1106  
Fax: (714) 870-6473  
Email: [parts@kairak.com](mailto:parts@kairak.com)

# 11. WARRANTIES

Kairak's warranty coverage warrants that Kairak-branded products are free of defects in materials and factory workmanship. The following applies to all Kairak Model and Serial numbers.

Kairak's warranty is extended only to the original purchaser and shall not apply to any failures resulting from damage in transit, improper installation, alteration, normal wear, misuse, abuse, improper voltage, accident or negligence. The warranty excludes; T-stat adjustments, time clock adjustments, gaskets, cutting boards, filters, clogged drains, ice build-up with no mechanical failures, and the loss of contamination of food due to mechanical or electrical failure. Warranty does not apply outside the United States.

In order to be covered under this warranty, prior authorization to perform the necessary and appropriate service must be obtained from the factory. Model and Serial number must be provided at the time of service request. Kairak does not assume responsibility for any expenses, including labor, parts or travel expenses incurred without such prior authorization. Kairak shall not be liable, whether in contract or in tort or under any other legal theory for loss of use, revenue or profit, substitute use or performance, incidental, indirect or special and/or consequential damages, loss of refrigerant or for any other loss or cost of similar type. Such related charges will be back charged to the responsible party. The decision of the Kairak Service and Warranty, as to whether a defect is within the terms of this warranty shall be final.

Failure to object or provision contained in a customer's purchase order or other communication shall not be deemed as a waiver of terms or conditions of their warranty, nor shall it be considered acceptance of such provisions. This warranty supersedes and is in lieu of all other warranties, expressed or implied and of other obligations of liabilities, on the part of Kairak.

In case of freight damage, do not refuse shipment, but call agent's attention to its condition, making careful note of the details on freight bill before freight charges are paid. File claim for damages with freight agent immediately.

**BLU FIXTURES** manufactured by Kairak hold a 3-year parts and labor warranty. Kairak holds a 5-year compressor warranty, with a one-time compressor only replacement after the first year. Kairak will warranty the labor to replace the compressor for the first three years, 30 days from the ship date. After the first three years, labor, tax, shipping and miscellaneous parts will not be included. Please contact our warranty department for compressor replacement procedures during the warranty period. BLU remote Fixtures are designed to operate with Kairak remote systems only. Violation of these terms will void all warranty.

**REFRIGERANT FIXTURES** manufactured by Kairak hold a 1-year parts and labor warranty. Kairak holds a 5-year compressor warranty, with a one-time compressor only replacement after the first year. Kairak will warranty the labor to replace the compressor for the first year, 30 days from the ship date. After the first year, labor, tax, shipping and miscellaneous parts will not be included. Please contact our warranty department for compressor replacement procedures during the warranty period.

**REMOTE SYSTEMS** manufactured by Kairak hold a 1-year parts and 90-day labor warranty on the remote system, with an option to purchase 1-year labor warranty at the time of purchase order receipt. This warranty does not apply to motors, switches, controls, accessories or parts manufactured by others and purchased by Kairak, unless the manufacturer warranties the same to Kairak. Kairak holds a 5-year compressor warranty, with a one-time compressor only replacement after the first year. Kairak will warranty the labor to replace the compressor for the first year, 30 days from the ship date. After the first year, labor, tax, shipping and miscellaneous parts will not be included. Please contact our warranty department for compressor replacement procedures during the warranty period.

**TO REQUEST AUTHORIZED SERVICE, CALL THE KAIRAK SERVICE AND WARRANTY HOTLINE: (800) 833-1106.** After-hour requests must be urgent in nature and documented with Kairak's after-hours service line prior to service being performed. Kairak is responsible for straight time only, unless otherwise approved by the warranty department.

## 12. SERVICE PARTS LIST

**NOTE:** Part numbers listed are for standard products as currently manufactured. For products manufactured as other than standard, please contact the factory. Drawers: Models with a \* next to model number are designed with two pan configurations. Determine which is needed based on configuration of drawer.

ITEM	DESCRIPTION	PART NUMBER
<b>CASTER</b>	<b>ALL MODELS</b>	
	4" ADJUSTABLE CASTER NO LOCK	SER-60536-00
	4" ADJUSTABLE CASTER WITH LOCK	SER-60536-01
<b>DRAWER</b>	<b>1 PAN SIDE-BY-SIDE MODELS KE036 &amp; KE065*</b>	
	DRAWER ASSEMBLY	550-10053-00
	DRAWER FACE ASSEMBLY	550-10057-00
	DRAWER FRAME ASSEMBLY	550-10059-00
	DRAWER FRAME INSERT	SER-60537-00
	DRAWER GASKET	341-60176-02
	DRAWER ROLLER	344-60155-00
<b>DRAWER</b>	<b>2 PAN SIDE-BY-SIDE MODELS KE048, KE065*, KE084, &amp; KE139</b>	
	DRAWER ASSEMBLY	550-10054-00
	DRAWER FACE ASSEMBLY	550-10058-00
	DRAWER FRAME ASSEMBLY	550-10060-00
	DRAWER FRAME INSERT	SER-60537-01
	DRAWER GASKET	341-60176-03
	DRAWER ROLLER	344-60155-00
<b>DRAWER</b>	<b>3 PAN SIDE-BY-SIDE MODELS KE060 &amp; KE125*</b>	
	DRAWER ASSEMBLY	550-10067-00
	DRAWER FACE ASSEMBLY	550-10076-00
	DRAWER FRAME ASSEMBLY	550-10077-00
	DRAWER FRAME INSERT	SER-60537-03
	DRAWER GASKET	341-60176-04
	DRAWER ROLLER	344-60155-00
<b>DRAWER</b>	<b>2 PAN FRONT-TO-BACK MODEL KE072</b>	
	DRAWER ASSEMBLY	550-10074-00
	DRAWER FACE ASSEMBLY	550-10069-00
	DRAWER FRAME ASSEMBLY	550-10070-00
	DRAWER FRAME INSERT	SER-60537-02
	DRAWER GASKET	341-60176-01
	DRAWER ROLLER	344-60155-00
<b>LOUVER</b>	<b>ALL MODELS</b>	
	LOUVER PANEL LEFT HAND SYSTEM	500-70075-00
	LOUVER PANEL RIGHT HAND SYSTEM	500-70075-01
<b>MICROPROCESSOR</b>	<b>ALL MODELS</b>	
	MICROPROCESSOR CONTROL HEAD	337-60403-00
	MICROPROCESSOR CABINET TEMPERATURE SENSOR	337-60405-03
	MICROPROCESSOR COIL TEMPERATURE SENSOR	337-60406-03
	MICROPROCESSOR LIQUID LINE TEMPERATURE SENSOR	337-60407-01
	MICROPROCESSOR RELAY MODULE	337-60317-00

# NOTES