

parts catalog

vulcano on demand

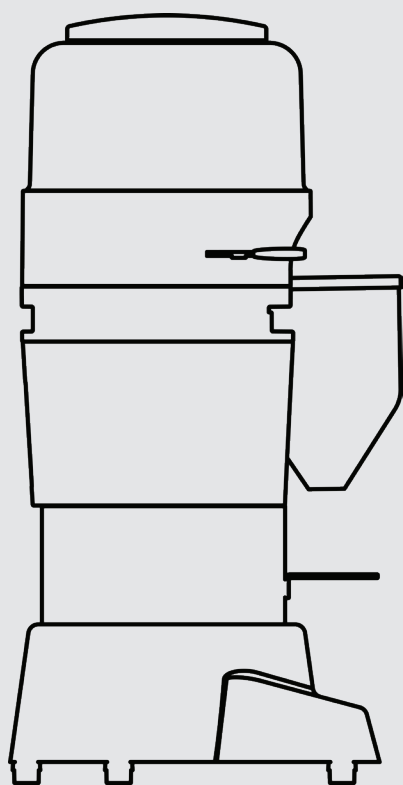





la marzocco

handmade in florence

VULCANO ON DEMAND dimensions

VULCANO GRINDER – DOSER

	mm	inches
A	240	9 ½
B	295	11 ¾
C	250	10
D	455	18
H	610	24
∅	235	9 ¼

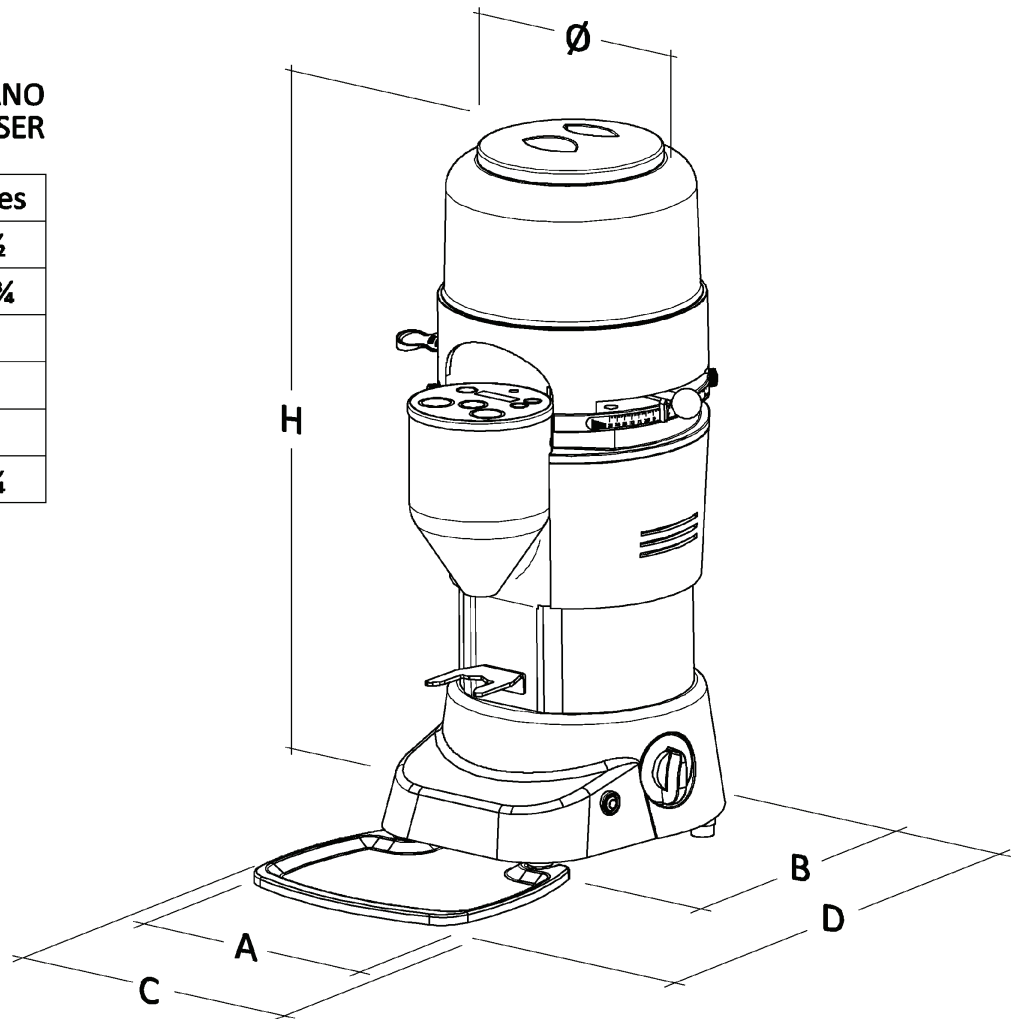



la marzocco

handmade in florence

NOTE:



la marzocco

handmade in florence

VULCANO ON DEMAND

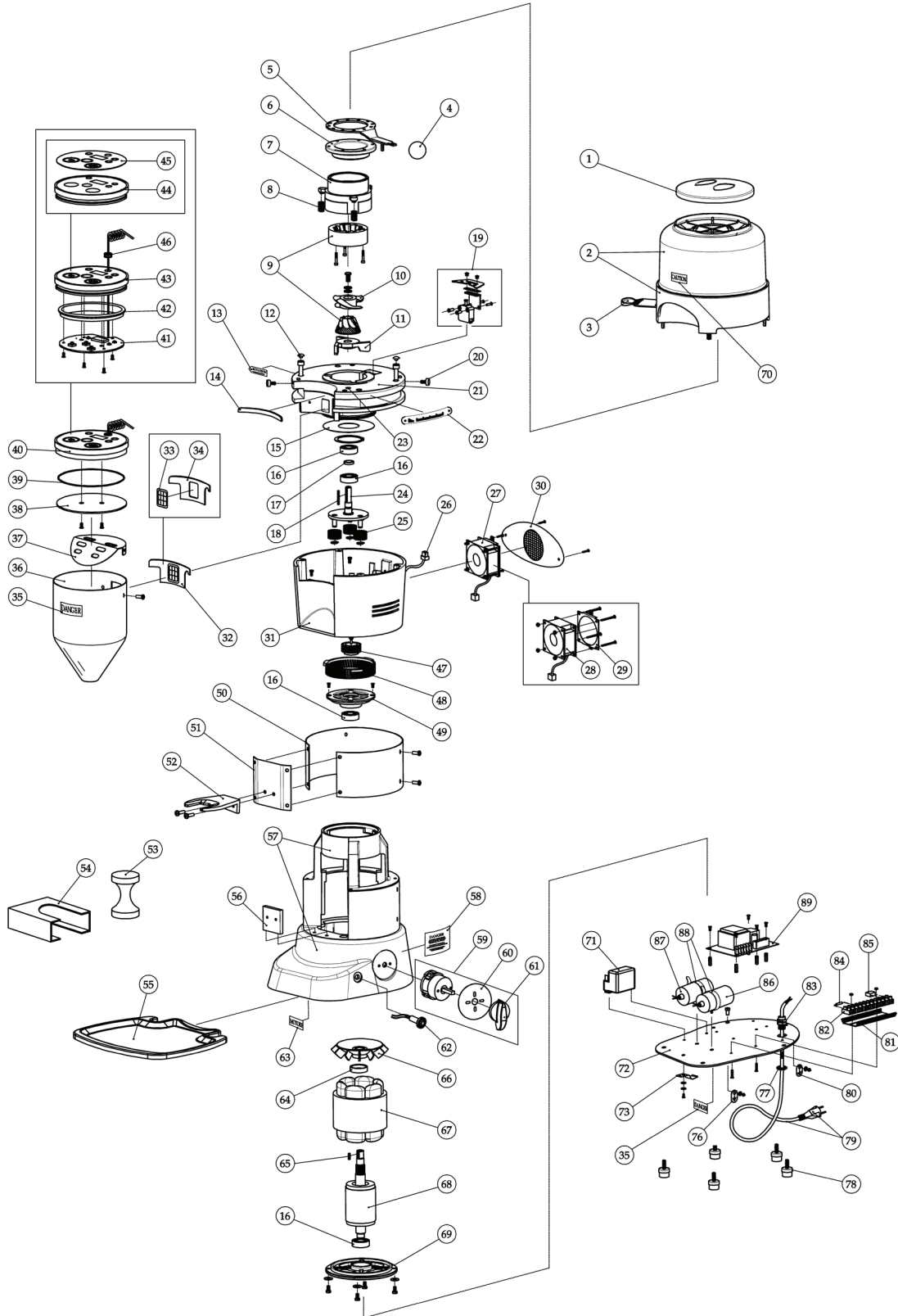



la marzocco

handmade in florence

VULCANO ON DEMAND

ON DEMAND

1	M.1.003	Hopper cover	
2	M.1.004	Complete Vulcano hopper set	
3	M.1.005	Vulcano locking slide	
4	M.1.006	Ball grip for adjustment lever	
5	M.1.007	Adjustment lever for Vulcano	
6	M.1.008	Vulcano coffee grinding adjustment disk	
7	M.1.009	Upper grinding blade holder single phase	
8	M.1.010	Grinding adjustment spring	
9	M.1.011	Conical grinding blade set	
10	M.1.012	Propeller single phase	
11	M.1.013	Lower grinding blade holder single phase	
12	M.1.014	Cap for TCE M6 screws	
13	M.1.015	Label: Motor rotation	
14	M.1.016	Upper gasket	
15	M.1.017	Disc to close body-head	
16	M.1.018	Bearing 6202 DDU CM	
17	M.1.019	Thickness planetary shaft	
18	M.1.020	Key 3x3x30 UNI 6604 A	
19	M.1.021	Safety microswitch	
20	M.1.022	Check pin for hopper for Vulcano	
21	M.1.023	Vulcano On Demand body-head	
22	M.1.024	Grinding adjustment indicator	
23	M.1.025	Hexagonal cable lock	
24	M.1.026	Shaft with 3 pivots for sigle phase	
25	M.1.027	Reduction satellite	
26	M.1.028	Connection cable for fan	
27	M.1.029	Fan 60x60 – wired with frame	
30	D.4.003	Filter for Vulcano On Demand	
31	M.1.033	Body for Vulcano On Demand	
32	M.1.034	Gasket with Grid type "C"	
33	M.1.035	Grid type "C"	
34	M.1.036	Gasket	
35	M.1.037	"Danger" label	Vers. 110 V/60 Hz Vers. 100 V/50-60 Hz Vers. 220 V/60 Hz
36	M.1.040	Funnel H160 Vulcano	
37	M.1.041	Coffee outlet guard	
38	M.1.042	Bottom for push button lid	
39	M.1.043	O-Ring 110.74x1.78 NBR70	
40	M.1.044	Assembly push buttons card with display	
42	M.1.046	Gasket push button holder lid	
43	M.1.047	Lid and adhesive membrane	
44	M.1.048	Push button holder lid with display window	
45	M.1.049	Adhesive membrane Vulcano	
Item	Codice	Descrizione	



la marzocco

handmade in florence

VULCANO ON DEMAND

ON DEMAND

46	M.1.050	Cable locking 40-80-20 black	
47	M.1.051	Reduction planet	
48	M.1.212	Reduction crown	
49	M.1.213	Bearing holder-disk	
50	M.1.054	Cover for Vulcano Automatic/On Demand	
51	M.1.055	Motor cover for Vulcano On Demand	
52	M.1.056	Fork for electronic	
53	M.1.057	Hand tamper double diam. D. 52.5 / 57.8	
54	M.1.058	Support for filter holder	
55	M.1.059	Drip tray	
56	M.1.060	Support for motor cover Vulcano On Demand	
57	M.1.061	Base and inner body	
59	M.1.064.R	Rotative switch. plate switch and switch	
60	M.1.065	Switch plate O / I	
61	M.1.066	Rotative switch knob	
62	M.1.067	Pilot light 230/400V - green	Vers. 220-230 V/50 Hz Vers. 230-240 V/50 Hz
	M.1.070	Pilot light 110V UL - red	Vers. 220 V/60 Hz Vers. 110 V/60 Hz Vers. 100 V/50-60 Hz
63		Motor label	
64	M.1.073	Fixing ring fan	
65	M.1.074	Key 4x4x14 UNI 6604 A	
66	M.1.075	Cooling fan	
67	M.1.076	Coiled stator single phase 220-240V/50Hz	Vers. 220-230 V/50 Hz Vers. 230-240 V/50 Hz
	M.1.078	Coiled stator single phase 110V/60Hz	Vers. 110 V/60 Hz Vers. 100 V/50-60 Hz
	M.1.080	Coiled stator single phase 220V/60Hz	Vers. 220 V/60 Hz
68	M.1.081	Rotor	
69	M.1.082	Motor cap	
70	M.1.083	Label: "Caution - Hopper"	Vers. 110 V/60 Hz Vers. 100 V/50-60 Hz Vers. 220 V/60 Hz
	M.1.086	Relè "Texas" 4CR1-625	Vers. 220-230 V/50 Hz
	M.1.087	Relè "Texas" 4CR1-630	Vers. 230-240 V/50 Hz
71	M.1.088	Relè "Texas" 4CR1-640	Vers. 220 V/60 Hz
	M.1.089	Relè "Texas" 4CR1-670	Vers. 100 V/60 Hz
	M.1.090	Relè "Texas" 4CR1-690	Vers. 110 V/60 Hz Vers. 100 V/50 Hz
72	M.1.092	Vulcano On Demand bottom plate	
Item	Codice	Descrizione	



la marzocco

handmade in florence

NOTE:



la marzocco

handmade in florence

VULCANO ON DEMAND

ON DEMAND

73	M.1.093	Sheet for Drip Tray locking	
76	M.1.094	"External unipotential clamp" plate	Vers. CE
77	M.1.095	Nut for PG11 cable locking	
78	M.1.096	Foot DD2015H	
79	M.1.097	Electric cable - "Italy"	
	M.1.098	Electric cable - "Europe"	
	M.1.099	Electric cable - "USA"	
	M.1.100	Electric cable - "Australia"	
	M.1.101	Electric cable - "Great Britain"	
	M.1.102	Electric cable - "Israel"	
	M.1.103	Electric cable - "Switzerland"	
	M.1.104	Electric cable - "China"	
	M.1.105	Electric cable - "Argentina"	
80	M.1.107	"Ground" plate	
81	M.1.109	Terminal blocks	12 poles
82	M.1.109	Under terminal blocks	12 poles
83	M.1.110	Capacitor 0,47 uF	Vers. 220-230 V/50 Hz
			Vers. 230-240 V/50 Hz
			Vers. 220 V/60 Hz
84	M.1.111	Load resistor 220 Kilo-ohm 2 Watt	Vers. 220-230 V/50 Hz
			Vers. 230-240 V/50 Hz
	M.1.112	Load resistor 68 Kilo-ohm 2 Watt	Vers. 110 V/60 Hz
			Vers. 100 V/50-60 Hz
85	M.1.113	Flexible Cable locking NSK-K PG11 black	
86	M.1.114	Capacitor 12.5 uF	Vers. 220-230 V/50 Hz
			Vers. 230-240 V/50 Hz
	M.1.115	Capacitor 40 uF UL	Vers. 220 V/60 Hz
			Vers. 110 V/60 Hz
			Vers. 100 V/50-60 Hz
87	M.1.116	Capacitor 10 uF	Vers. 220-230 V/50 Hz
			Vers. 230-240 V/50 Hz
	M.1.117	Capacitor 30 uF UL	Vers. 220 V/60 Hz
	M.1.115	Capacitor 40 uF UL	Vers. 110 V/60 Hz
			Vers. 100 V/50-60 Hz
88	M.1.119	Strap RELF 170 black	
89	M.1.120	Board for double timer 220-240V el. C	Vers. 220-230 V/50 Hz
			Vers. 230-240 V/50 Hz
	M.1.121	Board for double timer 100-115V el. C	Vers. 220 V/60 Hz
			Vers. 110 V/60 Hz
			Vers. 100 V/50-60 Hz
Item	Codice	Descrizione	

LA MARZOCCO SRL
Via La Torre, 14/H
Localita' La Torre
50038 Scarperia e San Piero
(Florence) - ITALY
T. +39 055 849 191
F. +39 055 849 1990
info@lamarzocco.com
www.lamarzocco.com