

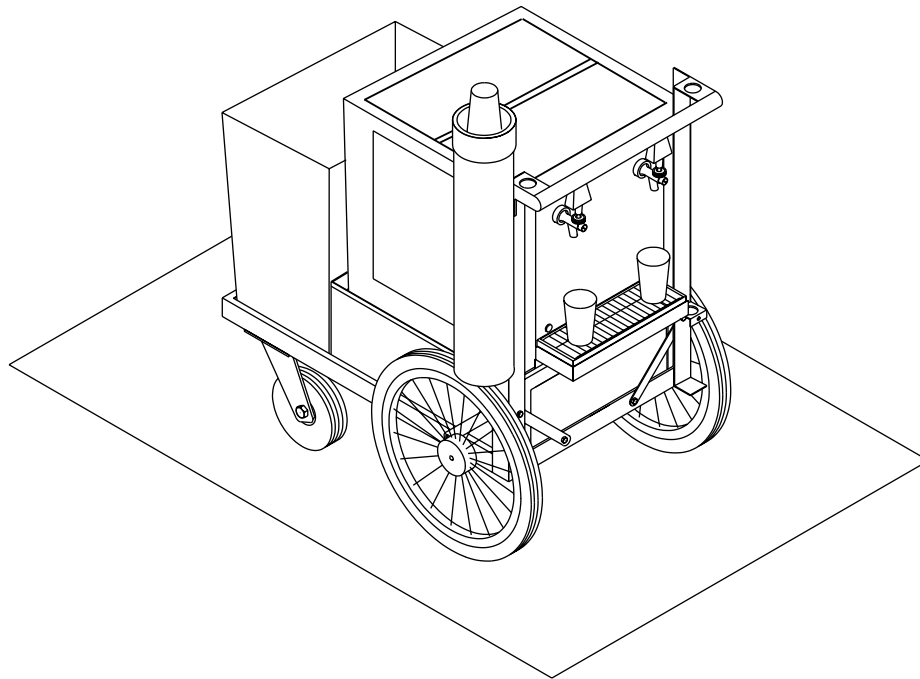

Please refer to the Lancer web site (www.lancercorp.com) for information relating to Lancer Installation and Service Manuals, Instruction Sheets, Technical Bulletins, Service Bulletins, etc.

INSTALLATION AND SERVICE MANUAL
FOR
TWO LITER PREMIX
PUSH CART
(Part Number 85-1751)



This manual is an initial release



6655 LANCER BLVD. • SAN ANTONIO, TEXAS 78219 USA • (210) 310-7000

FAX SALES

• NORTH AMERICA – 210-310-7245 • INTERNATIONAL SALES – 210-310-7242 • CUSTOMER SERVICE – 210-310-7242 •
• LATIN AMERICA – 210-524-9567 / 210-310-7245 • EUROPE – 32-2-755-2399 • PACIFIC – 61-8-8268-1978 •

FAX ENGINEERING: • 210-310-7096

"Lancer" is the registered trademark of Lancer • Copyright — 1997 by Lancer, all rights reserved.

DATE:	01/27/97
P.N.	28-0325

TABLE OF CONTENTS

TABLE OF CONTENTS	i
SPECIFICATIONS	i
1. PACKAGING AND INSPECTION	1
1.1 RECEIVING AND UNPACKING	1
1.2 COMPONENTS	1
2. ASSEMBLY	1
2.1 ASSEMBLY INSTRUCTIONS	1
2.2 CO ₂ REGULATOR ASSEMBLY	3
2.3 CUTTING THE BOTTLE TUBES	3
3. OPERATION	4
3.1 CUP DISPENSER	4
3.2 DISPENSING VALVE	4
3.3 CO ₂ PRESSURE ASSEMBLY	4
3.4 CO ₂ PRODUCT BOTTLES AND CO ₂ CYLINDER EXCHANGE	4
3.5 CO ₂ CYLINDER REFILL PROCEDURE	5
3.6 UNLOADING 2 LITER PET BOTTLES FROM PUSH CART ICE CUBE COOLER	5
4. MAINTENANCE	7
4.1 CUP DISPENSER	7
4.2 CLEANING AND SANITIZING	7
4.3 REPLACEMENT OF BEVERAGE HOSE INSIDE DISPENSING VALVE ASSEMBLY	7
4.4 CO ₂ CYLINDER	7
4.5 CO ₂ REGULATOR ASSEMBLY	8
5. ILLUSTRATIONS, PARTS LISTINGS, AND WIRING DIAGRAMS	10
5.1 COOLER AND HARDWARE	10-11
5.2 CO ₂ CYLINDER ASSEMBLY	11
5.3 REGULATOR ASSEMBLY	12
5.4 CONNECTOR VALVE ASSEMBLY	12
5.5 DISPENSING VALVE ASSEMBLY	13
5.6 CUP DISPENSER ASSEMBLY	13
5.7 REFILL ADAPTER ASSEMBLY	14
5.8 PRESSURE GAUGE TESTING ASSEMBLY	14

SPECIFICATIONS

CARBON DIOXIDE (CO₂) REQUIREMENTS

Pressure Regulator Setting	22 PSI (Preset)
Relief Valve Setting	30 PSI (Preset)
CO ₂ Cylinder Capacity	10 ounces of liquid CO ₂ (Sufficient for 5 complete discharges of each dispensing system)
CO ₂ Cylinder Refill	Use 50 pound CO ₂ Bottle <i>with a dip tube</i>

DRINK CAPACITY

The system consists of two (2) independent banks of five (5) two (2) liter bottles. Each bank is capable of providing 34 - 12 ounce cups or 24 - 16 ounce cups per one complete discharge using no ice in cup.

1. PACKAGING AND INSPECTION

1.1 RECEIVING AND UNPACKING

Open shipping case and carefully remove beverage dispenser components. Each unit has been thoroughly inspected and tested prior to shipment. Inspect all items for damage. In the event of shortage or damage, notify the delivering carrier (as well as Lancer) immediately. Merchandise should be inspected for concealed damage no later than 15 days after receipt.

1.2 COMPONENTS

- A. Installation and Service Manual
- B. CO₂ Cylinders
- C. Dispensing Valve Assemblies - two (2)
- D. CO₂ Regulator Assemblies - two (2)
- E. Eight (8) Bottle Connector/Valve Assemblies
- F. Cup Dispenser
- G. Graphics Panel (Optional)
- H. Refill Adapter (Optional)
- I. Pressure Gauge Assembly (Optional)

2. ASSEMBLY

2.1 ASSEMBLY INSTRUCTIONS

- A. Unpack the push cart and check the items received against the parts list.
- B. Assemble the push cart per the Instruction Sheet included with cart.

NOTE

The riser is supplied mounted to the Push Cart.

- C. Install the cup rest bracket on the push cart riser.

NOTE

The cup rest bracket sits on the riser, with the angle flange of the bracket inside the riser, the cube resting on the bracket to hold it down.

- D. Unpack the cup dispenser, and install the two mounting brackets on the push cart handle. The smaller tapered end of the bracket should be facing down.
- E. Unpack the cube, being careful to not damage the dispensing valves while unpacking. Place the cube on the riser, and on the angle flange of the cup dispenser.
- F. Place the drip tray in the cup rest bracket. Place the wire cup rest in the drip tray.
- G. Place the cup dispenser on the two mounting brackets. The black end of the cup dispenser is up (i.e., the cups are displaced up). Place cups in the cup dispenser.

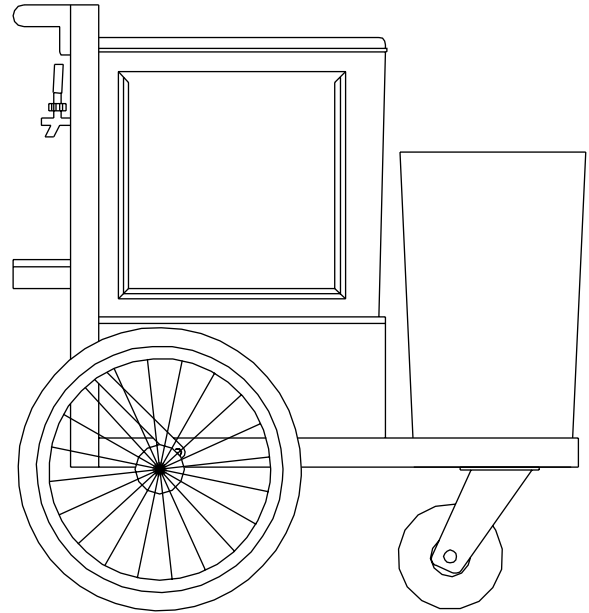

**Fully Assembled Push Cart
Side View
Figure 1**

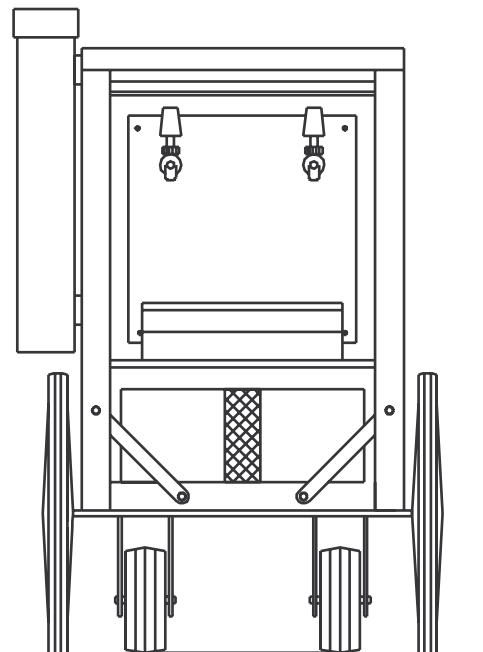

**Fully Assembled Push Cart
Backside View
Figure 2**

- H. Place the trash bin on the front of the cart as shown.
- I. Install the (optional) umbrella in the mounting bracket.
- J. Remove the caps of eight (8) 2 liter beverage products. Screw on the eight connector valve bottle fitting assemblies.

CAUTION

DO NOT OVER TIGHTEN THE FITTINGS. OVER TIGHTENING CAN CAUSE LEAKS! PLACE THESE BOTTLES IN THE SPRING FRAME AS SHOWN.

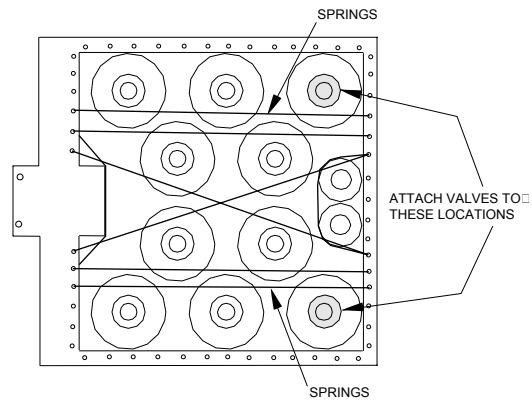

Bottle Hold Down Springs and Bottle Placement

Figure 3

- K. Remove the caps of two (2) 2 liter products. Screw the bottle onto the connector valve bottle fittings inside the cube that are connected to the dispensing valves. Place these two bottles in the spring frame farthest away from the valves (see Figure 3).

NOTE

Place the four (4) corner bottles in first. Then put the bottles in between them. Then put the four (4) center bottles in.

- L. Reverse this order to remove the bottles.
- M. Charge the two CO₂ cylinders following the instructions on the cylinders.

CAUTION

BE SURE TO WEIGH THE CYLINDERS AFTER CHARGING. THE FILLED WEIGHT MUST NOT EXCEED 1.0 KG, OR 2 LB., 3 OZ. FAILURE TO KEEP THE WEIGHT BELOW THIS AMOUNT COULD RESULT IN OVERPRESSURE OF THE CYLINDER, AND CAUSE THE SAFETY RELIEF VALVE TO OPEN.

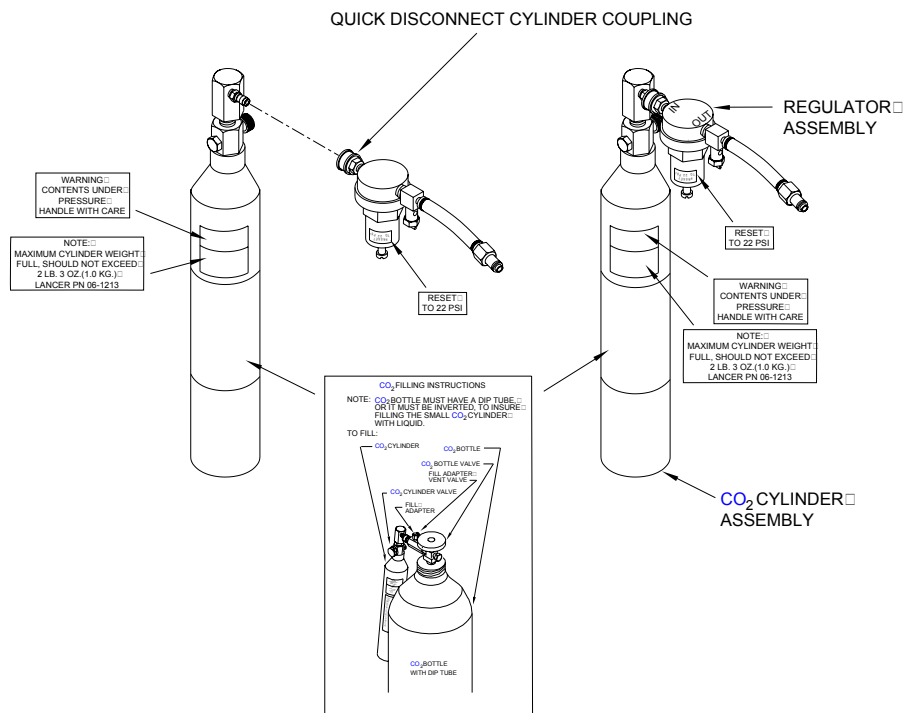

Quick Disconnect Cylinder Coupling

- N. Place the two cylinders in the spring frame as shown. Connect a regulator assembly to each of the cylinder assemblies, by pulling back on the quick disconnect body on the regulator, and pushing it on the stem on the cylinder assembly.
- O. Connect the regulator assembly and the bottles in series as follows: Plug the hose end of the regulator assembly into the fitting on the bottle fitting assembly, on the center bottle farthest away from the CO₂ cylinder. Plug the hose end from that bottle into the corner bottle next to the dispensing valves. Plug the hose end from that bottle into the center bottle along the side. Plug the hose end from that bottle into the center bottle next to the CO₂ cylinder. Plug the hose end from that bottle into the bottle with the hose that connects to the valves. Make sure the dispensing valves are closed.
- P. Open the CO₂ cylinder valve. Check for leaks.
- Q. Make sure the drain plug is in the drain hole in the bottom of the cube. Cover with ice as required.

NOTE

Do not allow water to rise above the spring frame.

2.2 CO₂ REGULATOR ASSEMBLY

- A. Attach CO₂ Regulator Assembly to CO₂ Cylinder, utilizing Quick Disconnect Cylinder Coupling (see Figure 4).
- B. Pull back Socket Sleeve to connect or disconnect coupling.

NOTE

Do not attempt to disconnect cylinder coupling while under pressure. Coupling will not disconnect.

2.3 CUTTING THE BOTTLE TUBES

Cutting the bottle tubes to the correct length is an important step. Bottle tubes are supplied as loose items, to be cut by the user to the correct length for the height of the bottles being used. Use the following procedure when cutting the bottle tubes (see Figure 5):

- A. Measure from the very bottom of an empty bottle, to the top of the bottle.

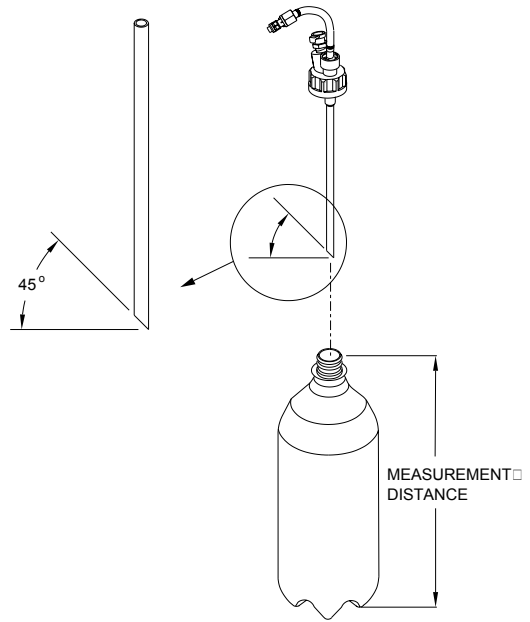

**Cutting the Bottle Tube
Figure 5**

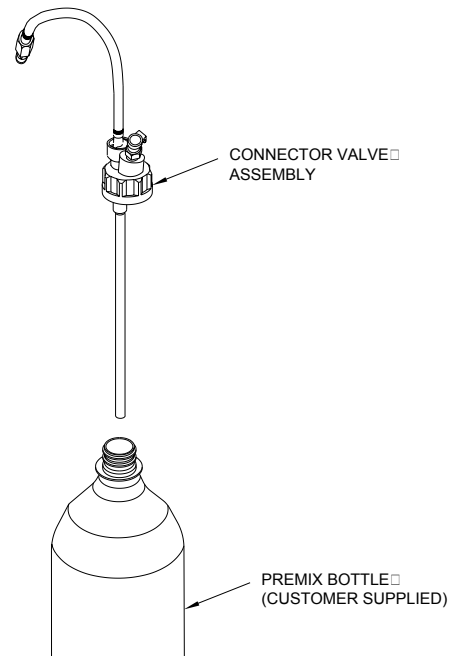

**Connector Valve Assembly
Figure 6**

- B. Cut the tubes 7/8 inch (22 mm) shorter than the height measured just above.
- C. If the end of the tube is not already cut at an angle, carefully cut the tube at a 45° angle.
- D. Push the tube onto the barbed end of the connector/valve bottle fitting assembly.
- E. Slowly open the valve on the CO₂ cylinder. Check for leaks. Close the lid of the cooler.

3. OPERATION

3.1 CUP DISPENSER

The Cup Dispenser will hold cup sizes ranging between 12 and 20 ounces in capacity.

3.2 DISPENSING VALVE

The Dispensing Valve will dispense any type of beverage product. Beverage flow is controlled by turning the Flow Screw on the Valve Body until desired flow is maintained (see Figure 8). The Product Hose is insulated to maintain constant product temperature regardless of environmental conditions. The Valve operates by pulling the handle forward, and upon release, the Valve will automatically close.

3.3 CO₂ PRESSURE ASSEMBLY

All beverage products are dispensed utilizing CO₂ pressure. Each CO₂ Cylinder has a rated capacity of ten (10) ounces of liquid CO₂ gas, which is sufficient to dispense five (5) complete refills of any type beverage product. The empty CO₂ Cylinder is then exchanged for a charged CO₂ Cylinder. CO₂ Cylinders may be refilled by the user through a fast, safe, and inexpensive method described in this manual, or CO₂ Cylinders may be refilled by a local commercial liquid gas supplier. It is advisable to maintain a supply of charged CO₂ Cylinders for quick exchange. The CO₂ Cylinder is ICC approved and equipped with a Safety Diaphragm Relief Valve.

A. Pressure Regulator setting

The Regulator pressure is preset to 22 PSI.

B. Safety Relief Valve setting

The Safety Relief Valve is preset to 30 PSI.

C. To disconnect CO₂ cylinder from regulator assembly

Follow the procedure below:

- (1) Close the Cylinder Valve.
- (2) Bleed off pressure through a Gas Socket.
- (3) Disconnect Cylinder, by pulling back sleeve on Cylinder Coupling.

3.4 CO₂ PRODUCT BOTTLES AND CO₂ CYLINDER EXCHANGE

Empty beverage bottles and an empty CO₂ Cylinder (when necessary) can be exchanged in about 30 seconds, upon the Vendor's return to the refill station.

NOTE

The 2 liter push cart contains two independent dispenser systems. The total number of servings per cart is therefore 2X the numbers shown the chart in Figure 7.

- A. Open lid of ice cube cooler.
- B. Disconnect the lines to the connector valve assembly on each bottle.
- C. Remove the bottle with the hose to the dispensing valve. Unscrew the Connector/Valve Assembly from that bottle.
- D. Follow steps (1) through (6) below, if the CO₂ Cylinder is to be exchanged.
 - (1) Remove CO₂ Cylinder Assembly.
 - (2) Close Cylinder Valve.
 - (3) Bleed off pressure through Gas Socket.
 - (4) Disconnect empty Cylinder from Regulator Assembly (normally, the Cylinder is not

NUMBER OF SERVINGS BY SIZE OF INDIVIDUAL SERVING	
ACTUAL PRODUCT SERVED IN OUNCES	NUMBER OF SERVINGS PER COMPLETE REFILL
12	34
16	24

Figure 7

completely empty, but do not bleed off as the small remaining amount is later used to facilitate refill).

- (5) Connect full (charged) Cylinder to Regulator Assembly.
 - (6) Open Cylinder Valve and replace CO₂ Assembly.
- E. Remove empty product bottles and replace with full 2-liter bottles of Premix.
 F. Connect Dispensing Valve Assembly to a bottle, and place into the unit or cooler.
 G. Connect CO₂ Assembly to bottle. Connect all lines to all bottles (see Figure 7). Close cover.
 H. Refill Cup Dispenser.

3.5 CO₂ CYLINDER REFILL PROCEDURE

- A. CO₂ Cylinder Assembly (PN 20-0016). CO₂ Cylinders may be refilled, following the outlined procedures below, at the rate of one (1) CO₂ Cylinder per minute. The following equipment is necessary to utilize the refill method:

NOTE

The fill adapter (PN 17-0385/01) is designed to be placed on USA CO₂ bottles with 0.830-14 NGO thread. If the threads are different on the CO₂ bottles being used, it will be necessary to make an adapter to interface between the CO₂ bottle being used and the adapter. An adapter is not supplied because of thread variances between bottles. It will be necessary to make an identical piece, with the threads on the female end identical to the threads on the CO₂ bottle being used.

- (1) Fifty (50) pound CO₂ supply bottle with a siphon (dip) tube. This should be available from any local commercial liquid gas supplier. A fifty (50) pound liquid CO₂ bottle will normally refill approximately seventy to seventy-two (70 to 72) CO₂ Cylinders.
 - (2) CO₂ Cylinder Refill Adapter (PN 17-0385/01).
 - (3) Scale with minimum graduations of a quarter ounce (1/4 ounce). Although an accurate spring scale is acceptable, a triple beam balance scale is preferable. Either scale may be obtained at a nominal cost from local suppliers.
- B. Refill Procedure (see Figure 8)
- (1) Connect Refill Adapter to liquid CO₂ supply bottle (50 pounds).
 - (2) Connect empty CO₂ Cylinder to Refill Adapter, utilizing Quick Disconnect Coupling. Close Refill Adapter Vent Valve.
 - (3) Open CO₂ Cylinder valve
(PN 20-0016).
 - (4) Open supply bottle valve for about three to five (3 to 5) seconds. Close valve.
 - (5) Open Refill Adapter Vent Valve, allowing pressure to disperse. This chills the CO₂ Cylinder. Close Refill Adapter Vent Valve.
 - (6) Open supply bottle valve until CO₂ Cylinder is filled (hissing sound will stop). Close supply bottle valve.

- (7) Close CO₂ Cylinder valve.
- (8) Open Refill Adapter Vent Valve. This disperses pressure. Disconnect CO₂ Cylinder from Refill Adapter.

NOTE

CO₂ Cylinder will not disconnect from Refill Adapter unless Refill Adapter Vent Valve has been opened.

CAUTION

DO NOT OPERATE CO₂ CYLINDER WHEN GROSS WEIGHT IS IN EXCESS OF THAT INDICATED ON THE CO₂ CYLINDER. THE CO₂ CYLINDER IS ICC APPROVED AND EQUIPPED WITH A SAFETY DIAPHRAGM RELIEF VALVE. IF OPERATED OR STORED WHEN THE WEIGHT IS IN EXCESS OF THAT RECOMMENDED, SEVERE HEAT MAY CAUSE THE SAFETY DIAPHRAGM RELIEF VALVE TO OPEN; THEREBY, DISPERSING EXCESSIVE PRESSURE. REFER TO MAINTENANCE SECTION, AND PARTS AND SERVICE SECTION, FOR INSTRUCTIONS ON REPLACING DIAPHRAGM.

CO₂ FILLING INSTRUCTIONS

NOTE: CO₂ BOTTLE MUST HAVE A DIP TUBE, OR IT MUST BE INVERTED, TO INSURE FILLING THE SMALL CO₂ CYLINDER WITH LIQUID.

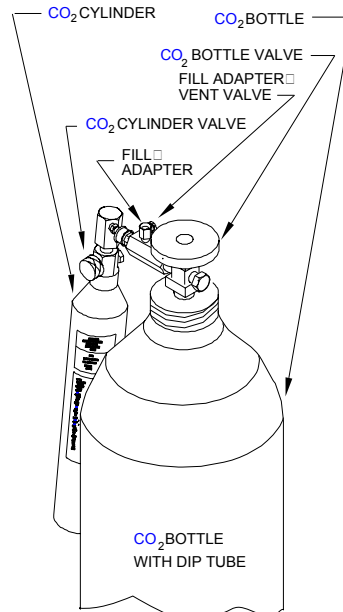

- TO FILL:
- (1) CLOSE THE FILL ADAPTOR VENT.
 - (2) CONNECT THE SMALL CO₂ CYLINDER TO THE FILL ADAPTER.
 - (3) OPEN THE VALVE ON THE SMALL CO₂ CYLINDER VALVE.
 - (4) OPEN THE CO₂ BOTTLE VALVE FOR 5 SECONDS. CLOSE THE VALVE.
 - (5) OPEN THE FILL ADAPTER VENT VALVE (THIS COOLS THE CO₂ CYLINDER). CLOSE THE VENT VALVE.
 - (6) OPEN THE CO₂ BOTTLE VALVE (LISTEN FOR THE GAS FLOW TO STOP).
 - (7) CLOSE THE CO₂ CYLINDER VALVE.
 - (8) CLOSE THE CO₂ BOTTLE VALVE.
 - (9) OPEN THE FILL ADAPTER VENT VALVE.
 - (10) DISCONNECT THE CO₂ CYLINDER FROM THE FILL ADAPTER.
 - (11) WEIGH THE CO₂ CYLINDER. THE MAXIMUM WEIGHT ALLOWABLE IS 1.0 KG (2 LB., 3 OZ.). IF THE CYLINDER IS OVERWEIGHT, OPEN THE VALVE TO EXHAUST GAS. RE-WEIGH THE CYLINDER.
- REPEAT AS REQUIRED TO REACH SPECIFIED WEIGHT.

**CO₂ Filling Instructions
Figure 8**

- (9) Weigh CO₂ Cylinder. If gross weight is over that indicated on the CO₂ Cylinder, bleed off pressure until referenced weight is achieved. The CO₂ Cylinder now contains ten (10) ounces of liquid CO₂ which is sufficient to dispense five (5) complete refills of any type beverage.

3.6 UNLOADING 2 LITER PET BOTTLES FROM PUSH CART ICE CUBE COOLER

- A. Release the quick disconnects from the bottle fittings.
- B. Remove the empty bottles from the cube.

WARNING

UNVENTED BOTTLES CAN BECOME PROJECTILES.

CAUTION

VENTING OF THE BOTTLE MUST OCCUR IMMEDIATELY WHEN THE FITTING IS TURNED 1/8 OF A TURN. IF VENTING DOES NOT TAKE PLACE, DEPRESS THE END OF THE QUICK DISCONNECT TO VENT.

- C. Remove the bottle fitting from the bottles.

4. MAINTENANCE

4.1 COOLER AND LID

- A. Scuff and dirt marks are readily and easily removed with a damp cloth and mild detergent, although stubborn marks may require a cleaner. At the end of each day's activity, the unit should be cleaned and allowed to air dry prior to storage.
- B. To drain the cube, pull out the plug in the bottom of the cube. The water will drain out of the bottom, through the riser, and through a pipe in the center of the riser. If the cube is removed and tipped to dump the ice, be careful to not damage the dispensing valves.

4.2 CUP DISPENSER

- A. The Cup Dispenser should be cleaned periodically with a damp cloth and detergent, or cleaner. The Cup Dispenser is constructed of Stainless Steel which helps to ensure a rust and corrosion free operation.
- B. See Section 5 for parts breakdown and related information.

4.3 CLEANING AND SANITIZING

- A. Bottles are to be discarded after each use. However, five (5) empty 2-liter bottles must be retained for cleaning and sanitizing the unit.
- B. Prepare a sanitizing solution of between 50 to 150 PPM of available chlorine, not to exceed 200 PPM and fill one (1) bottle with sanitizing solution.
- C. Assemble four (4) empty product bottles into the hold down frame. Place the remaining product bottle (filled with sanitizing solution in Step B above) into the frame and connect to the CO₂ Cylinder/Regulator Assembly.
- D. Connect the CO₂ cylinder/pressure regulator to the bottle with sanitizing solution.
- E. Connect the four (4) empty, de-pressurized bottles in series, downstream of the sanitizer bottle.
- F. Turn on the valve on the CO₂ cylinder.
- G. Activate the dispensing valve until all the sanitizing solution has been dispensed through the system.
- H. Shut off the CO₂.
- I. Depressurize by opening the dispensing valve until all pressure is exhausted.
- J. Unscrew the connector/valve assembly from each bottle. Drain all sanitizing solution from each assembly. Drain the cube by pulling the plug in the bottom of the cube.

NOTE

If necessary, push the end of the male fitting of the connector/valve assembly to allow the liquid solution to drain from the hoses of the connector/valve assembly. Also drain the dispensing valve hose assembly.

- J. Rinse the exterior of all bottle fittings with the sanitizing solution.
- K. Air dry in a clean environment. Cover if necessary.

4.4 CO₂ CYLINDER

CAUTION

FOR THE FOLLOWING PROCEDURE, DO **NOT** HOLD THE CO₂ CYLINDER WITH A JAW TYPE WRENCH, OR A VISE. A JAW TYPE WRENCH WILL MAR THE CYLINDER, WEAKEN THE CYLINDER WALL, AND POSSIBLY CAUSE A FAILURE. CLAMPING THE CO₂ CYLINDER IN A VISE WILL CRUSH THE CYLINDER, AGAIN WEAKENING THE CYLINDER WALL, AND WILL RESULT IN CYLINDER FAILURE.

HOLD THE CO₂ CYLINDER WITH A STRAP WRENCH. THE STRAP WRENCH WILL HAVE A LEATHER OR CLOTH TYPE STRAP, THAT WILL NOT MAR THE CYLINDER SURFACE.

The CO₂ Cylinder used by the cart is virtually free of maintenance. *If any maintenance is required, other than that described below, return the CO₂ Cylinder to Lancer for repair.*

A. Safety Diaphragm Relief Valve

If the Safety Diaphragm Relief Valve leaks, or the Diaphragm has ruptured due to extreme pressure, follow the instructions provided below. For a parts breakdown, see Section 5.

The safety relief valve is not replaceable. In the event this valve ruptures or leaks, replace the complete valve (PN 17-0514) as follows:

- (1) Open Cylinder Valve and exhaust all CO₂ pressure.
- (2) Remove adapter from the CO₂ valve.

- (3) Remove the CO₂ valve.

NOTE

Hold the CO₂ cylinder with a strap wrench as noted above.

- (4) Install new CO₂ valve. Torque to 20.0 ft lbs.
- (5) Install adapter. Torque to 20.0 ft lbs.
- (6) Charge the CO₂ cylinder. Check for leaks.

B. Repairing Leaks on the CO₂ Cylinder Assembly

If a leak should occur because of a failed O-Ring, replace the defective O-Ring:

- (1) Between the cylinder and the CO₂ valve.
 - a. Open the CO₂ cylinder valve to exhaust all of the CO₂ pressure.
 - b. Remove the CO₂ valve from the cylinder.

NOTE

Hold the CO₂ cylinder with a strap wrench as noted above.

- c. Replace the O-Ring (PN [02-0219](#)) on the valve.
 - d. Lubricate the O-Ring slightly with a silicone spray.
 - e. Install the valve on the cylinder. Torque to 20.0 ft lbs.
- (2) Between the CO₂ valve and the adapter.
 - a. Open the CO₂ cylinder valve to exhaust all of the CO₂ pressure.
 - b. While holding the CO₂ valve with a wrench, remove the adapter.
 - c. Replace the O-Ring (PN [02-0003](#)).
 - d. Install the adapter on the valve. Torque to 20.0 ft lbs.

- (3) ***For any other leaks, return the CO₂ cylinder assembly to Lancer.***

4.5 CO₂ REGULATOR ASSEMBLY

For Parts breakdown and related information, see Section 5.

A. Hose Connector

If leakage occurs in the Hose Connector, replace the Hose Connector and hose.

B. CO₂ Cylinder Coupling (Socket)

If leakage occurs between the Socket and the Plug, when the CO₂ Regulator assembly is coupled with the CO₂ Cylinder, disconnect and visually inspect the Socket O-Ring. If the O-Ring is nicked, cut, or otherwise defective, replace the O-Ring.

C. CO₂ Regulator

CO₂ Regulators cannot be disassembled for maintenance without special equipment and should be returned to Lancer for any needed repair. The following procedure can be used to check the regulator pressure.

- (1) A pressure gauge testing assembly (PN 82-1751) is available to check the relief valve/regulator pressure (see Section 5.8).
- (2) If it is necessary to check or readjust the pressure, follow these steps:

NOTE

The pressure testing assembly is to be used to check the pressure of the regulator assembly only if the pressure from the regulator assembly (PN 18-0274) is not correct.

- (a) Plug the pressure testing assembly onto the male fitting of the regulator assembly.
- (b) On the CO₂ cylinder, turn on the valve. The pressure of the regulator should be 22 PSI.

- (c) If necessary, readjust the regulator to the correct pressure, by loosening the locknut, adjusting the screw to the correct pressure, then tighten the locknut.
- (3) Plug the gauge assembly onto the regulator assembly (see Figure 9).
- (4) Connect the regulator assembly to a CO₂ cylinder assembly. Open the CO₂ cylinder valve.
- (5) The regulator pressure valve should be at 22 PSI, \pm 3 PSI.
- (6) To reset, back off the lock nut on the regulator, and back out the adjusting screw.
- (7) Disconnect the gauge assembly, and push in the end of the male fitting to relieve the pressure in the regulator assembly.
- (8) Connect the gauge assembly.
- (9) Turn the adjusting screw until the correct pressure is obtained
- (10) Lock the adjusting screw with the lock nut.

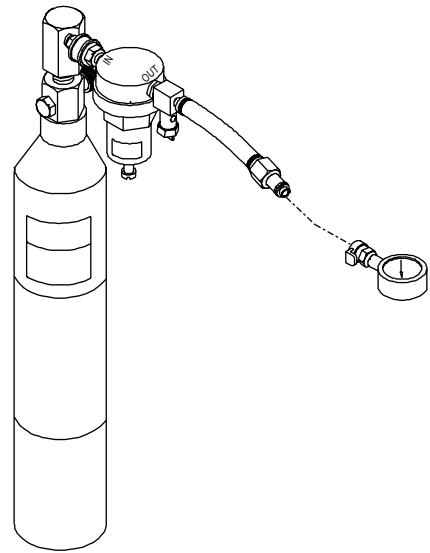

**Pressure Testing
Figure 9**

D. Relief Valve/Check valve

The relief valve/check valve cannot be field repaired. In the event of failure, replace with a new valve (PN 17-0517). The relief pressure is preset, and is not to be field adjusted.

NOTES

5. ILLUSTRATIONS, PARTS LISTINGS, AND WIRING DIAGRAMS

5.1 COOLER AND HARDWARE

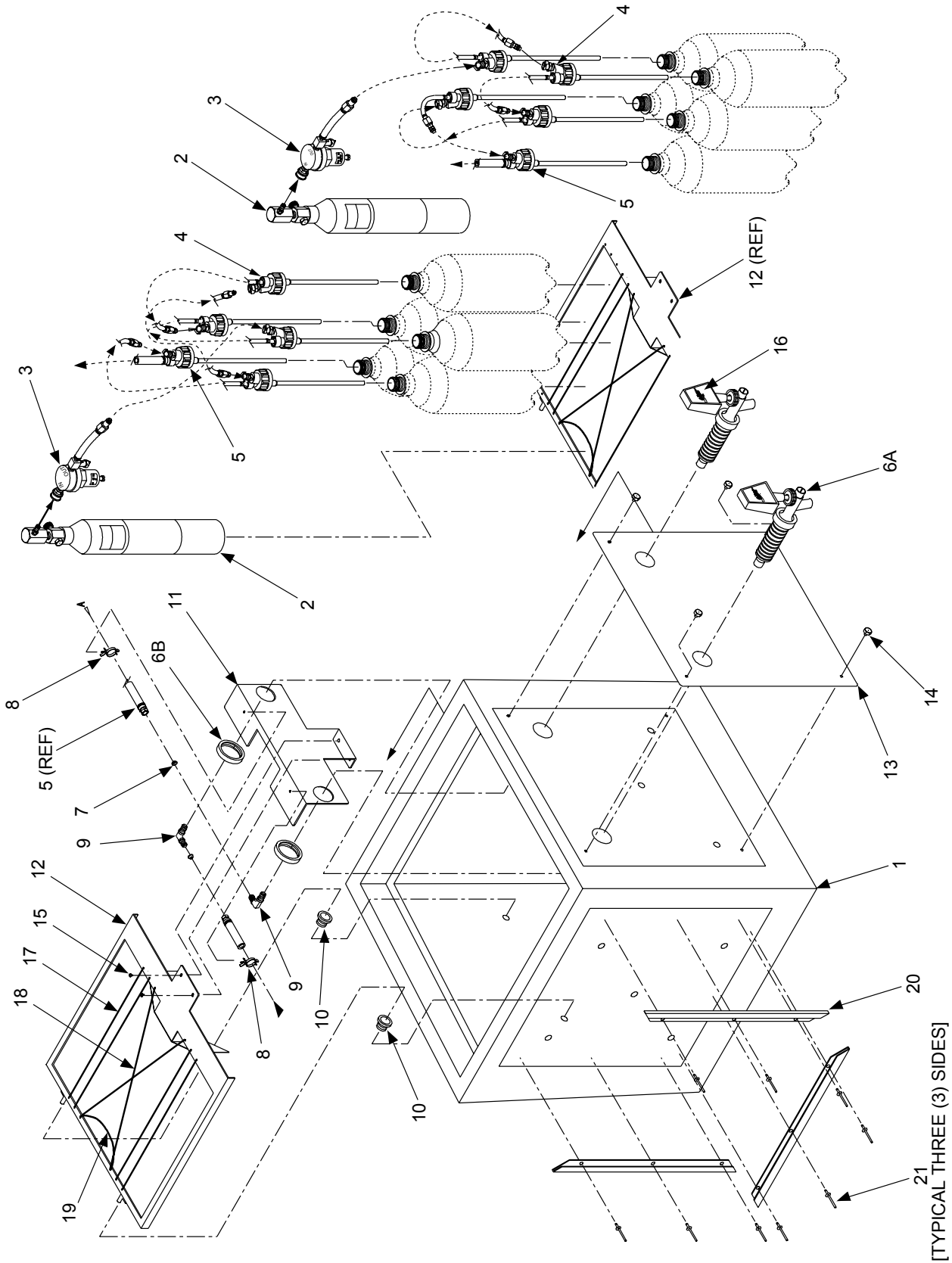

5.1 COOLER AND HARDWARE (CONTINUED)

ITEM	PART NO.	DESCRIPTION	ITEM	PART NO.	DESCRIPTION
1	23-0918	Cube Assy, with Covers	12	82-1785	Assy, Frame, Hold Down
2	20-0016	Cylinder Assy	13	30-6302	Plate, Front Escutcheon
3	18-0274	Regulator Assy	14	04-0816	Screws, Self-Tapping, 8 x 0500, TEK
4	17-0509	Connector/Valve Assy	15	04-0448	Screw, 8 - 32 x 0.250 LG
5	17-0526	Connector/Valve Assy, to Valve	16	82-1184	Kit, Label, 8 Flavor
6	19-0003	Dispensing Valve, with Handle (includes attaching nut)	17	03-0260	Spring A, Bottle Hold Down
7	05-0011	Washer	18	03-0261	Spring B, Bottle Hold Down
8	13-0087	Retainer, Standoff Lock Clip	19	03-0262	Spring C, Cylinder Hold Down
9	01-1369	Elbow Adapter	20	05-1196	Molding, J-Shaped
10	04-0811	Insert, Push In, Barbed	21	04-0815	Poprivets, 1/8 inch, Aluminum
11	30-6314	Plate, Hold Down			

5.2 CO₂ CYLINDER ASSEMBLY

WARNING:
CONTENTS UNDER
PRESSURE:
HANDLE WITH CARE

NOTE:
MAXIMUM CYLINDER WEIGHT:
FULL, SHOULD NOT EXCEED:
2 LB. 3 OZ.(1.0 KG.):
LANCER PN 06-1213

CO₂ FILLING INSTRUCTIONS

NOTE: CO₂ BOTTLE MUST HAVE A DIP TUBE, OR IT MUST BE LAID ON ITS SIDE, TO INSURE FILLING THE SMALL CO₂ CYLINDER WITH LIQUID.

TO FILL:

- (1) CLOSE THE FILL ADAPTER VENT VALVE.
- (2) CONNECT THE SMALL CO₂ CYLINDER TO THE FILL ADAPTER.
- (3) OPEN THE VALVE ON THE SMALL CO₂ CYLINDER.
- (4) OPEN THE CO₂ BOTTLE VALVE FOR 3 SECONDS. CLOSE THE VALVE.
- (5) OPEN THE FILL ADAPTER VENT VALVE (THIS COOLS THE CO₂ CYLINDER). CLOSE THE VENT VALVE.
- (6) OPEN THE CO₂ BOTTLE VALVE. LISTEN FOR THE GAS FLOW TO STOP.
- (7) CLOSE THE CO₂ CYLINDER VALVE.
- (8) CLOSE THE CO₂ BOTTLE VALVE.
- (9) OPEN THE FILL ADAPTER VENT VALVE.
- (10) DISCONNECT THE CO₂ CYLINDER FROM THE FILL ADAPTER.
- (11) WEIGH THE CO₂ CYLINDER. THE MAXIMUM WEIGHT ALLOWABLE IS: 1.0 KG (2 LB. - 3 OZ.). IF THE CYLINDER IS OVERWEIGHT, OPEN THE VALVE TO EXHAUST GAS. RE-WEIGH THE CYLINDER. REPEAT AS REQUIRED TO REACH SPECIFIED WEIGHT.

ITEM	PART NO.	DESCRIPTION
1	20-0016	CO ₂ Cylinder Assy
2	20-0015	Cylinder
3	02-0219	O-Ring
4	17-0514	Valve, CO ₂
5	02-0003	O-Ring
6	01-1620	Adapter
7	17-0518	Plug Fitting
8	06-1213	Label, Warning
9	06-1218	Label, How to Fill

5.3 REGULATOR ASSEMBLY

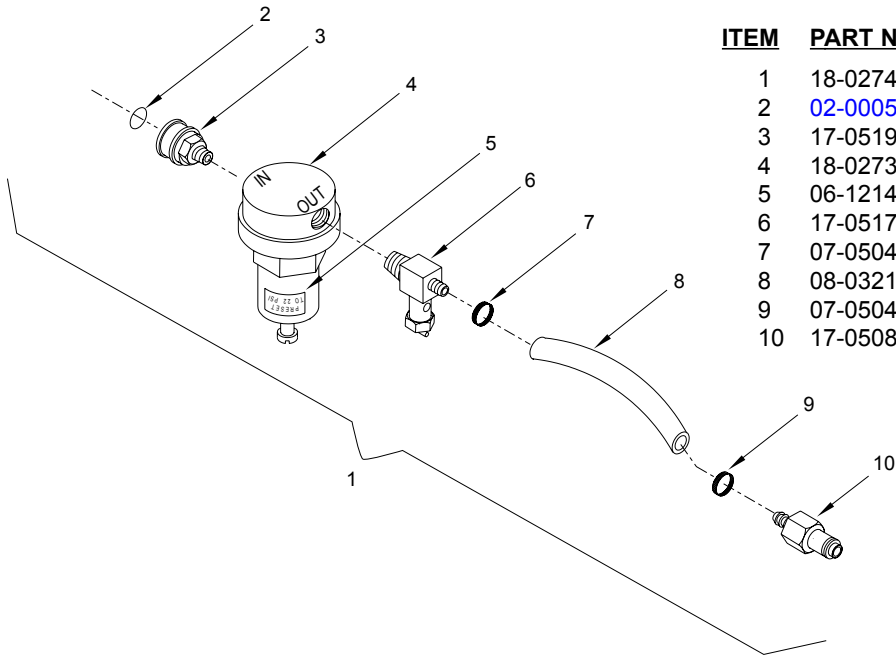

ITEM	PART NO.	DESCRIPTION
1	18-0274	Regulator Assy
2	02-0005	O-Ring
3	17-0519	Coupling, Quick Disconnect
4	18-0273	Regulator Valve
5	06-1214	Label
6	17-0517	Relief/Backflow Check Valve
7	07-0504	Clamp
8	08-0321	Hose
9	07-0504	Clamp
10	17-0508	Fitting, Plug

5.4 CONNECTOR VALVE ASSEMBLY

ITEM	PART NO.	DESCRIPTION
1	17-0509	Connector Valve Assy
2	17-0507	Fitting, Coupling
3	07-0504	Clamp
4	17-0508	Fitting, Plug
5	08-0321	Hose, Out
6	07-0504	Clamp
7	03-0191	Clip, Retainer
8	04-0756	Washer
9	02-0419	O-Ring
10	05-1072	Connector/Valve Body
11	02-0158	O-Ring
12	01-1604	Fitting, Connector/Valve Body
13	08-0322	Hose, Bottle

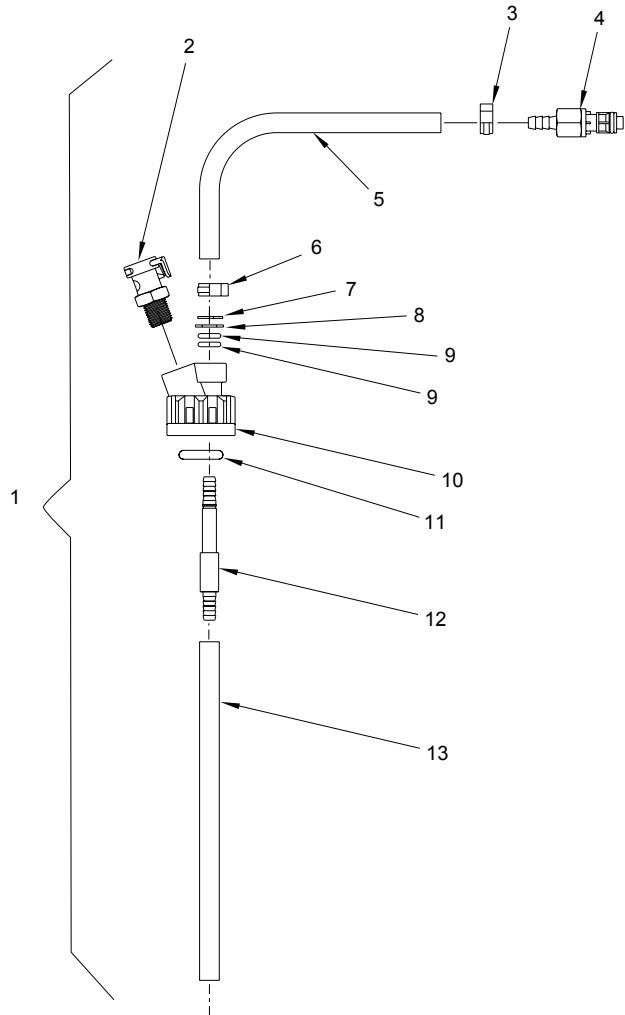

5.5 DISPENSING VALVE ASSEMBLY

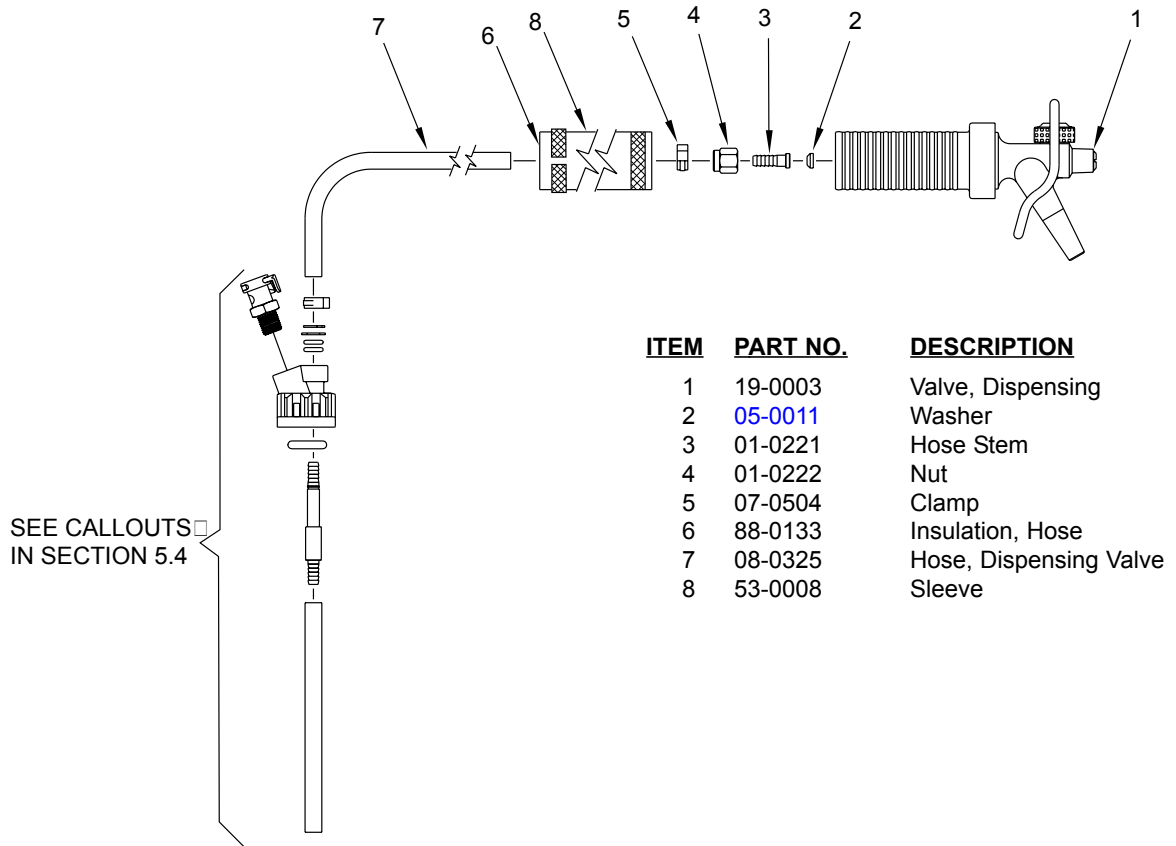

5.6 CUP DISPENSER ASSEMBLY

<u>ITEM</u>	<u>PART NO.</u>	<u>DESCRIPTION</u>
1	23-0935	Cup Dispenser Assy

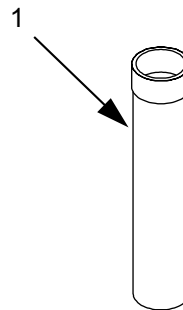

5.7 REFILL ADAPTER ASSEMBLY

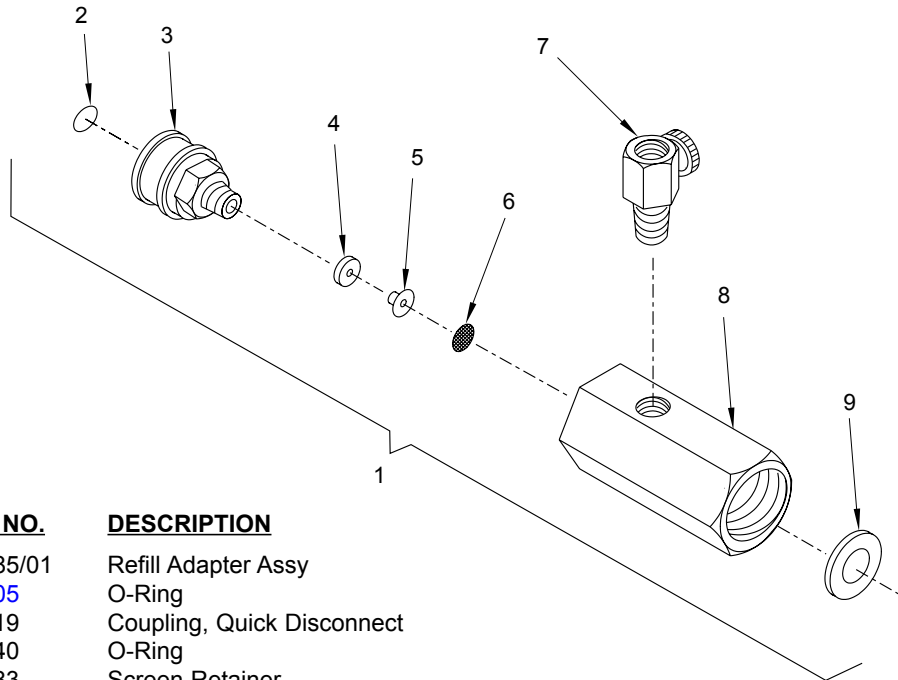

ITEM	PART NO.	DESCRIPTION
1	17-0385/01	Refill Adapter Assy
2	02-0005	O-Ring
3	17-0519	Coupling, Quick Disconnect
4	02-0140	O-Ring
5	01-0283	Screen Retainer
6	07-0007	Screen
7	17-0520	Vent Valve
8	01-1643	Body, Refill Adapter
9	02-0342	Washer

5.8 PRESSURE GAUGE TESTING ASSEMBLY

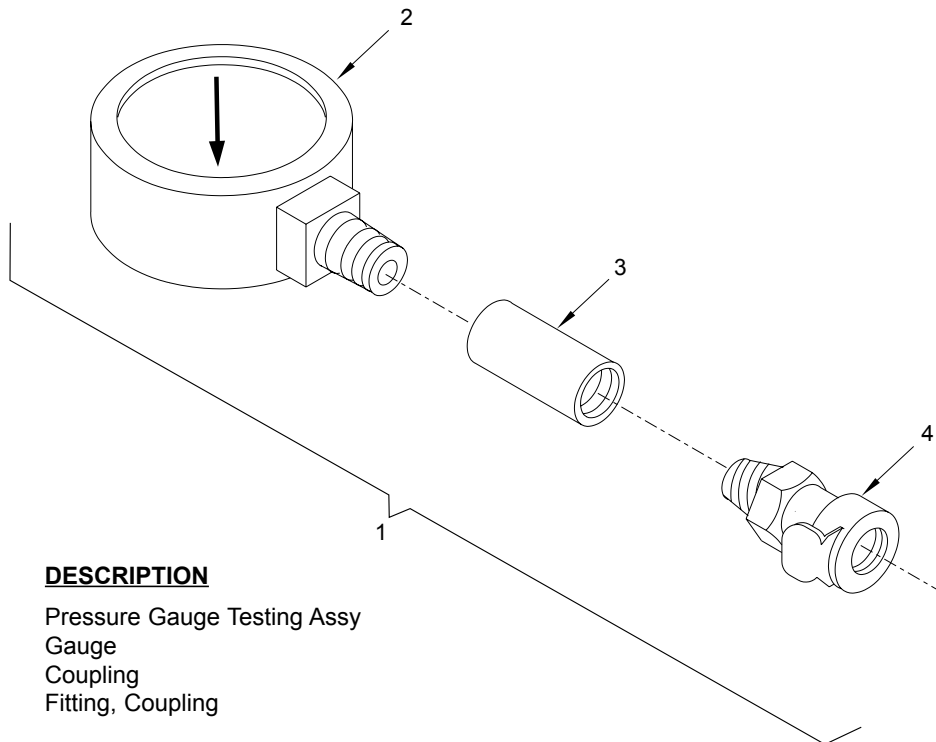

ITEM	PART NO.	DESCRIPTION
1	82-1751	Pressure Gauge Testing Assy
2	16-0025	Gauge
3	01-1631	Coupling
4	17-0524	Fitting, Coupling