



Model LCR7W

7-Spit Rotisserie Oven with Wash System Operator's Manual

LBC Bakery Equipment, Inc.

6026 31st Ave NE

Tulalip, WA 98271, USA

Phone: 888-RACKOVN (888-722-5686)

Fax: 425-642-8310

Email: service@lcbakery.com

READ FIRST

THIS MANUAL MUST BE RETAINED FOR FUTURE REFERENCE. READ, UNDERSTAND AND FOLLOW THE INSTRUCTIONS AND WARNINGS CONTAINED IN THIS MANUAL. IT IS THE RESPONSIBILITY OF THE OWNER/OPERATORS OF THIS APPLIANCE TO TRAIN, SUPERVISE AND AUTHORIZE ANY PERSON DESIGNATED AS AN OPERATOR. ALL OPERATORS MUST READ AND UNDERSTAND THIS MANUAL.

	WARNING DO NOT STORE OR USE GASOLINE OR OTHER FLAMMABLE VAPORS AND LIQUIDS IN THE VICINITY OF THIS OR ANY OTHER APPLIANCE.	
	WARNING IMPROPER INSTALLATION, ADJUSTMENT, SERVICE OR MAINTENANCE CAN CAUSE PROPERTY DAMAGE, INJURY OR DEATH. READ THE INSTALLATION, OPERATING AND MAINTENANCE INSTRUCTIONS THOROUGHLY BEFORE INSTALLING OR SERVICING THIS EQUIPMENT.	
	CAUTION ALWAYS KEEP THE AREA NEAR THE APPLIANCE FREE FROM COMBUSTIBLE MATERIALS.	

Your LBC Rotisserie was manufactured to rigid standards. The appliance has been tested and is listed by Intertek Testing Services (ETL Semko) and meets applicable safety and sanitation standards.

- A The **responsibility of the manufacturer** is to supply suitable, comprehensive instructions and recommendations for proper operation and maintenance.
- B All operations, maintenance and repair of this or any appliance must be performed by properly trained and qualified personnel, and all such operations, maintenance and repair must be performed in a diligent manner. It is the **responsibility of the owner/operator** to ensure proper training and diligence of any person coming into contact with either the subject units or the output (product, fumes or otherwise) of the subject units. It is the **responsibility of the owner/operator** to ensure that the subject units are installed and operated in accordance with OSHA Standard 1910.263.
- C A regular periodic program of cleaning, inspection and maintenance must be established and comprehensive maintenance records maintained. It is the **sole responsibility of the owner/operator** to establish, schedule and enforce the frequency and scope of these programs in keeping with recommended practice and with due consideration given to actual operating conditions.
- D The appliance must be operated within limits which will not exceed its working limits. It is the **responsibility of the user** to operate this appliance in accordance with the rules and limits described in this manual and the published product specification sheet, and in accordance with the directions and instructions of the

owner/operator of the appliance or employer, and in accordance with applicable federal, state and local laws and ordinances.

TABLE OF CONTENTS

CHAPTER	PAGE
Read First	2
Safe Operating Rules	4
Equipment Description	6
Configurations	7
Control Overview	8
Operation	
How to Program and Save a Recipe	10
How to Run a Recipe	11
Resetting the Timer	13
How to Use the Wash System	13
Maintenance	16
Parts List	17
Warranty	18

SAFE OPERATING RULES (Part 1 of 2)

YOU MUST READ AND UNDERSTAND THIS SECTION BEFORE YOU OPERATE THIS APPLIANCE.

Hot Surfaces

- The appliance may be hot. Do not contact hot surfaces in the appliance interior without proper protection. Contact with hot surfaces can cause serious burns, loss of skin and hair and the use of limbs.
- The appliance door may not stay open and may close on its own.
- Avoid contact with hot surfaces when loading or unloading the oven. Use cooking mitts to handle spits, forks or baskets. Contact with hot product can cause you to react suddenly and result in spilling or dropping the product, which can cause physical harm.

Hot Water and Steam

- This appliance produces steam in the process of cooking. When opening the loading door, hot air and steam will be released from the oven interior. Steam is very hot and contact can cause serious burns, loss of skin and hair, loss of the use of limbs and serious injury to eyes and internal organs. Excessive contact with steam can even result in loss of life. Open the loading door slowly and keep your face and hands clear of the opening.
- Steam produced by the appliance can cause the floor to become wet. If this happens, wipe or mop up the water and alert other employees of the hazard.
- Steam and/or hot water may be expelled through the appliance drain. The drain line should be connected to a proper air gap drain during installation to allow excess water to be evacuated from the work area. Steam and water from the drain may be very hot and contact can cause serious burns, loss of skin and hair, loss of the use of limbs and serious injury to eyes and internal organs.
- Use caution to avoid slipping when operating this appliance or when in the area of the appliance. In the event that the drain becomes clogged, continued use of the appliance may result in water spilling onto the floor in the general work area around the appliance. If the drain becomes clogged and water spills on the floor:
 - Turn the appliance off to prevent more water spillage.
 - Mop up and clean up any water on the floor in front of the appliance or in the surrounding work area.
 - Alert other personnel, employees, customers or observers of the hazard.
 - Notify supervisor, servicer or maintenance persons and have the drain unclogged.
- In the normal operation of the appliance, product intended for cooking may spill onto the floor. If this happens:
 - Mop up and clean up any product on the floor in front of the appliance or in the surrounding work area.
 - Alert other personnel, employees, customers or observers of the hazard.

Sharp Edges and Pinch Hazards

- Use caution to avoid contact with sharp edges. Doors, covers, etc. may have edges that can cut or snag skin and clothes. Use caution when working on, cleaning or servicing the appliance.
- Keep hands and fingers out of the path of the loading door when closing to avoid pinching.

Strains, Over-Extension, Over-Exertion and Lifting Hazards

- Use caution when loading or unloading heavy product from the appliance. Cooked product may be heavy and result in sprains, strains or injury to back, arms, hands or legs. Do not lift more than you are safely capable of lifting.

Other Precautions

- Never stand on top of the appliance for any reason.
- Do not store anything on top of the appliance.
- Do not attempt to burn off surface contamination.

SAFE OPERATING RULES (Part 2 of 2)

YOU MUST READ AND UNDERSTAND THIS SECTION BEFORE YOU OPERATE THIS APPLIANCE.

Smoke or Fire Hazard

- If you see flames or smoke in or around the appliance:
 - Turn the appliance off and contact your supervisor or an authorized service provider.
 - Call 911 or contact fire safety personnel in accordance with your employer's emergency plan.
 - **Do not open the loading door** as this will allow oxygen to reach any flames and may cause injury to persons, property damage and may cause loss of life.
- Do not operate the appliance or any other appliance if you hear bangs, pops or other abnormal noises. Turn off the appliance and contact your supervisor or authorized service provider.
- Do not allow any flammable materials to be put into the appliance. The following materials are flammable:
 - Gasoline and petroleum products, including wax and tar.
 - Wood chips, wood and paper.
 - Flour dust and fine corn meal that can become airborne.
 - Charred baked products or any other burned material.
- If a fire suppression system discharges while you are operating the appliance, turn off the appliance and follow your employer's emergency plan, or exit the building or work area.
- Do not operate the appliance if an attached fire suppression system or fire alarm system is dysfunctional or has been discharged. Contact your supervisor or contact the fire safety system servicer.

Electrical Hazard

- Do not operate the appliance if electrical covers are removed or there are frayed, burned or exposed wires or if any live electrical terminals are exposed. Turn off the appliance and any circuit breaker or disconnect device supplying electrical power to the appliance as described in your employer's emergency plan.
- Do not operate the appliance if any circuit breaker or fuse connected to the appliance becomes tripped and cannot be reset. Contact your supervisor or authorized servicer or electrician to correct the condition before operating the appliance. Alert other employees and service personnel to the hazard.
- Do not operate the appliance if you feel an electrical shock when in contact with the appliance or other devices attached to the appliance. Contact your supervisor or authorized servicer or electrician to correct the condition before operating the appliance. Alert other employees and service personnel to the hazard.

Improper Operation

- Do not operate the appliance if covers, doors or other components are removed.
- Do not operate the appliance if any other person has applied a lock-out on the electrical supply or has tagged the appliance in a way to suggest that the appliance not be used. Contact your supervisor for further instructions or refer to your employer's safety plan.

Health and Safety in Cooked Products

- For the safety and health of those who will consume goods produced through the use of the appliance, use all caution and diligence to prevent the ingestion of any item or material that is unsafe or unfit for human consumption.
- Do not use the appliance if you see any material floating in the air in the appliance or if you see any foreign matter in the finished food product.
- Do not use the appliance if you smell unfamiliar smells or if you smell any odor that you know to be unhealthy.
- Do not under-cook any product that can carry bacteria such as but not limited to E.coli, salmonella or any other pathogen.
- Do not cook, roast or handle any meat or meat product that contains any known diseases or pathogens.
- In all cases, follow all food-safe practices as mandated by law and your employer.

EQUIPMENT DESCRIPTION

Exterior Dimensions

- 39.4" Height 39.9" Width 31.9" Depth (Single Door)

NOTE 1: The depth shown is for the LCR7W-1D single-door oven, measured from the door front surface and excluding handle. For the LCR7W-2D double-door oven, measured between the front and rear door outer surfaces, deduct 1.1". NOTE 2: The height shown does not include a stand or legs. For the stand add 32.1". For legs add 7.0".

Construction

- The exterior top, front, rear and sides are constructed of stainless steel, as is the oven cook cavity (including the carousel parts, dip plates, forks, spits and baskets). The underside is constructed of stainless steel and corrosion-resistant aluminized steel.
- The loading door includes double-pane tempered safety glass with a low-energy coating for increased efficiency. The inner pane is hinged to make cleaning easier.
- The oven cook cavity is insulated with high-temp insulation for reduced heat loss and increased energy efficiency.
- A high-output halogen lamp is located at the upper front ceiling of the oven to thoroughly illuminate the cook chamber for easy viewing.

Performance

- Fast-acting heater elements are utilized for energy-efficient convective cooking.
- Top-mounted fans thoroughly circulate convection air for even browning of the food product.

Capacity

- 28—35 Chicken Capacity

Controls

- Simple, intuitive and easy-to-understand layout.
- Large displays for time, temperature and recipe number.
- Sear, roast and warm/hold event buttons to facilitate recipe setups.
- Up to 3-event recipe capability.
- Storage for up to 3 recipes.
- 6 quick-select buttons for your most-frequently-used recipes.
- Carousel and interior fans automatically stop when loading door is opened and automatically resume when door is closed.
- Press-and-hold jog button to rotate carousel while door is open for easier loading and unloading.
- Buzzer alarm to indicate end of cook cycle.
- Washdown feature with choices for standard wash (1X) and heavy wash (2X).

CONFIGURATIONS

**Countertop or
Floor Mount**

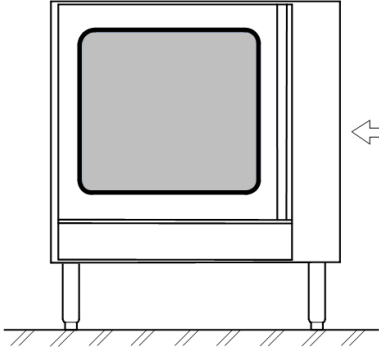

← **LCR7W Rotisserie**

Stand Mount

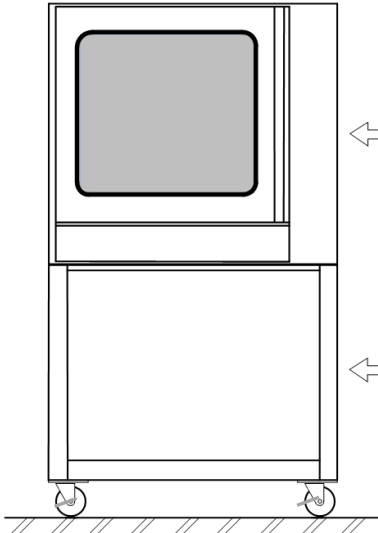

← **LCR7W Rotisserie**

← **LST7 Stand**

CONTROL OVERVIEW (Part 1 of 2)

See pages 9 for more thorough descriptions of the features shown below.

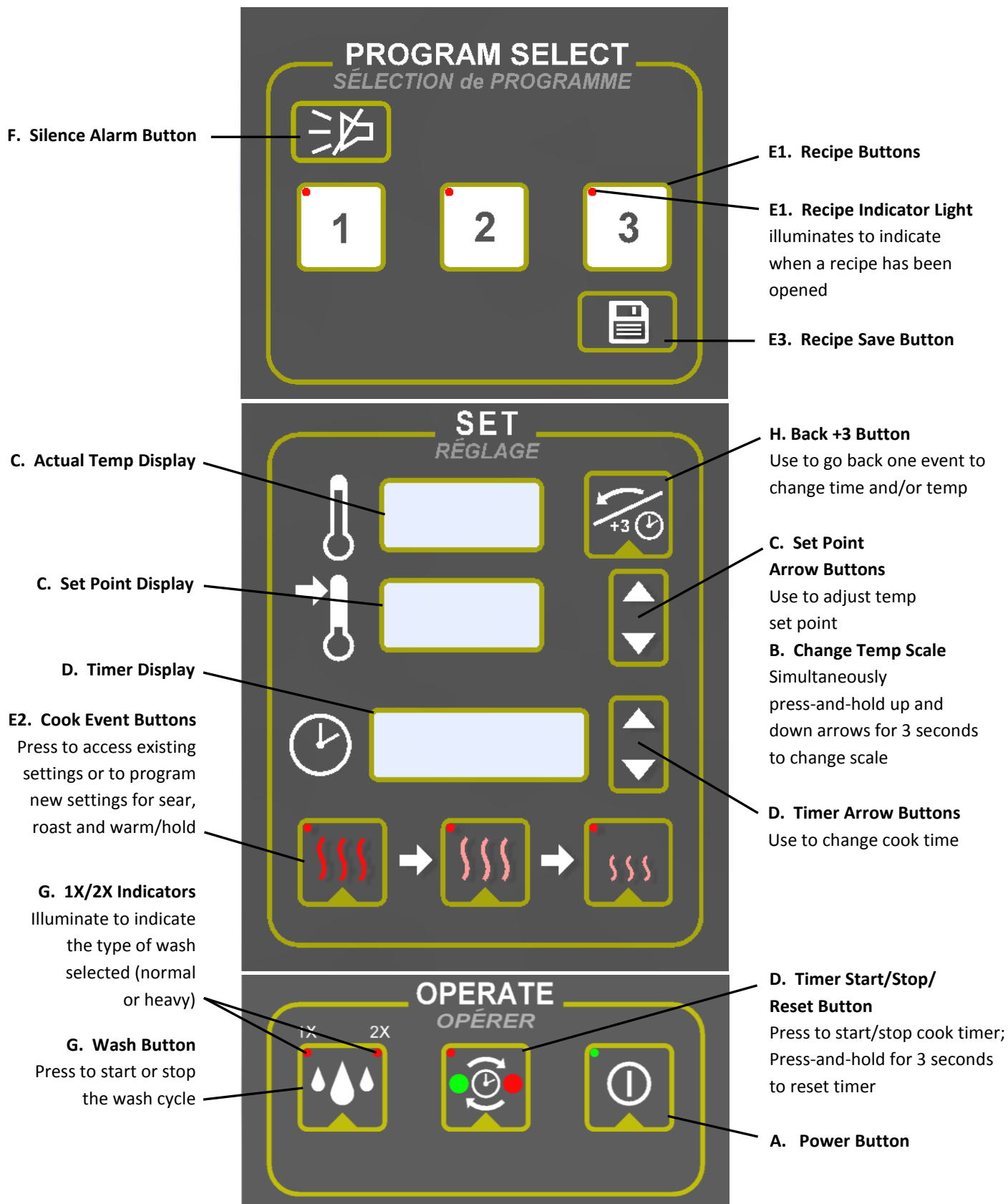

CONTROL OVERVIEW (Part 2 of 2)

NOTICE

During the first few hours of operation, you may notice a small amount of smoke coming from the rotisserie and/or a faint odor. This is normal in a new oven and will disappear after a few hours of use.

- A Power Button.** Press this button to turn the oven on or off. The Power indicator light will remain on whenever the appliance is connected to an electrical supply.
- B Change Temperature Scale.** The oven can display temperatures in either °F or °C. To change from one scale to the other, simultaneously press-and-hold both set point arrows for 3 seconds. Unless selected otherwise, this scale will remain active for all future startups. Saved recipes will automatically change to the selected scale.
- C Set Point and Actual Temperature.** Use the set point arrows to enter the desired temperature, which will appear in the adjacent set point display. The oven will heat or cool to match the set point. The oven interior temperature will appear in the actual temp display
- D Cook Timer.** The timer start/stop/reset button can be used in the following ways:
- 1 Start the Timer.** Press the timer start/stop button once to start the timer. When the timer is counting, a “spinning” indicator will appear in the timer display. If the loading door is opened while the timer is counting, the countdown will automatically pause. The countdown will resume when the door is closed. A buzzer will sound when the timer has counted to zero. Press the silence alarm button to stop the buzzer.
 - 2 Stop the Timer.** If the timer is counting, press the start/stop button again to stop the countdown. When the timer is stopped, the spinning timer indicator will disappear and timer button status light will flash. Press the timer start/stop button again to restart the timer.
 - 3 Reset the Timer.** Press-and-hold the button for 3 seconds to reset the timer.
- E Recipe Features**
- 1 Recipe Buttons.** Up to 3 recipes may be stored. A status light on one of the recipe buttons will illuminate to indicate which recipe is active.
 - 2 Cook Event Buttons.** The sear, roast and warm/hold buttons allow you to create up to 3 cooking steps.
 - 3 Save Button.** Press the save button twice to save a recipe.
- F Silence Alarm Button**
- G Wash Button.** When the cook/wash handle is set to wash, the oven automatically begins to operate in 1X (normal) wash mode. Press the wash button to select the 2X (heavy) wash mode for heavier cleaning. Press the wash button a second time to return to the 1X (normal) wash mode. To exit the wash mode and return to cook mode, turn the cook/wash handle to cook. NOTE: When the oven completes the wash cycle, it will automatically turn itself off.
- H Back+3 Button.** A single press goes back event and adds three minutes to this event. Each additional press of this button adds 3 minutes to the event.

OPERATION (Part 1 of 6)

How to Program and Save a Recipe

- Press the power button to turn the oven on.

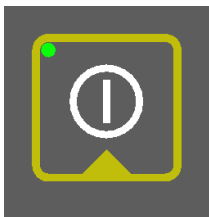

- Set the oven to cook mode. Turn the cook/wash handle to the left.

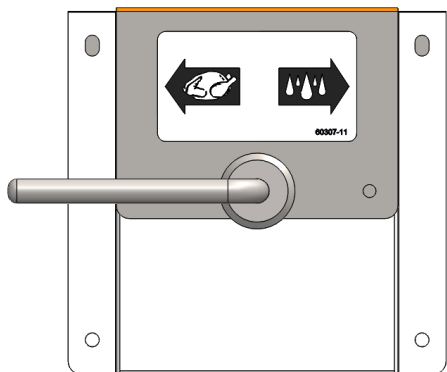

- Select your recipe. NOTE: The oven will automatically heat to the temperature shown in the set point display.

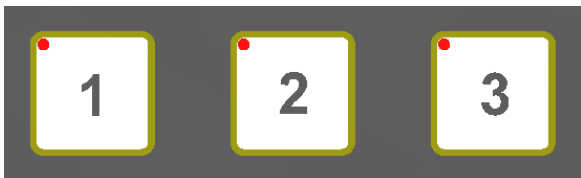

- Setup or deactivate the sear event. To setup, press the sear button and enter a set point and time. If you prefer to deactivate the sear event, enter a sear time of "0:00."

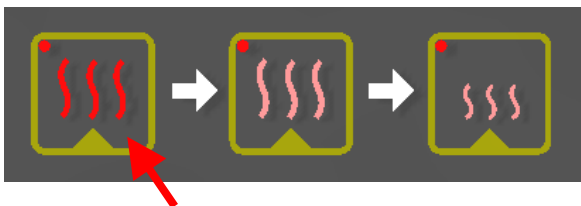

- Setup or deactivate the roast event. To setup, press the roast button and enter a set point and time. If you prefer to deactivate the roast event, enter a roast time of "0:00."

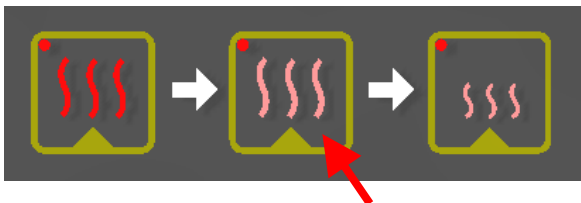

OPERATION (Part 2 of 6)

- **Setup the warm/hold event.** To setup, press the warm/hold button and enter a set point. (NOTE: The warm/hold step has no time parameter and the timer display will be blank.)

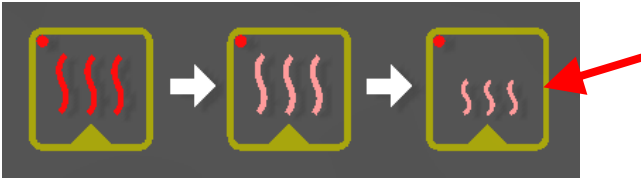

- **Press save button twice to save your recipe.** The oven will automatically adjust to the set temp of the first step with a time value.



How to Run a Recipe

- **Press the power button to turn the oven on.**

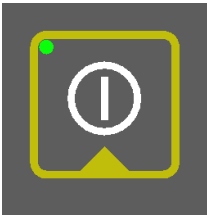

- **Set the oven to cook mode.** Turn the cook/wash handle to the left.

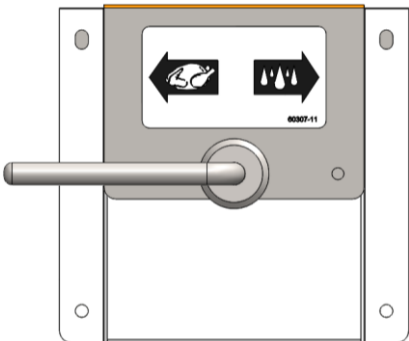

- **Select your recipe.** NOTE: The oven will automatically heat to the temperature shown in the set point display.



OPERATION (Part 3 of 6)

- **After the oven has reached temperature, an alert will sound and you may load your product for cooking.** Press the silence alarm button to silence oven. Press the yellow jog pushbutton to rotate the carousel wheel and release the button to stop the wheel.
- **Close the loading door and press the timer start button.** A “spinning” timer-counting indicator will appear in the timer display to indicate the timer is active and counting down. To pause the timer, press the timer button a second time. The timer indicator will disappear to show the timer is paused. Press the timer button a third time to resume the countdown. NOTE: The timer countdown will pause whenever the loading door is opened and resume when the loading door is closed again.

To reset the timer, press and hold the timer button for 3 seconds.

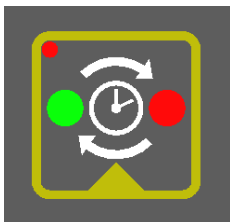

- **If needed, the temperature and/or time can be modified for the step showing in the control displays.** Only the currently-displayed step may be changed. To save the modifications, press the save button twice.



- **When the buzzer alert sounds to indicate the cook cycle has elapsed, press the silence alarm button.**



- **Open the door and check the internal temperature of the product with a temperature probe.** If necessary, the warm/hold temperature can be changed at this time.
- **If it is necessary to cook the product longer, use the back+3 button.** Pressing back+3 will move the recipe back one event and add 3 minutes to that event. Additional presses add 3 minutes for each press. The timer can also be changed for this event. The oven will automatically adjust temperature to the new setting.

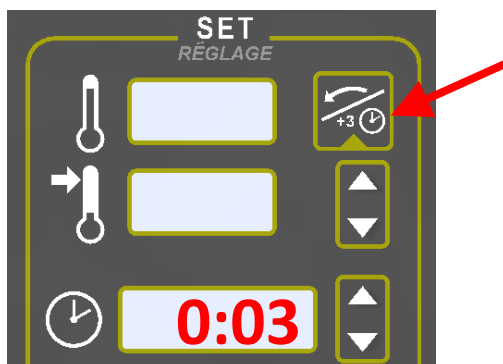

OPERATION (Part 4 of 6)

- **Remove the cooked product or leave it in the oven during the warm/hold step.** If removing the product and preparing for a subsequent cook, press and hold the timer start/stop button for 3 seconds to reset the original cook settings.

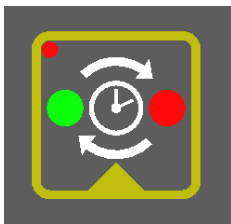

- **To save the changes, press the save button twice.**



- **To reset the timer, press and hold the timer button for 3 seconds.**

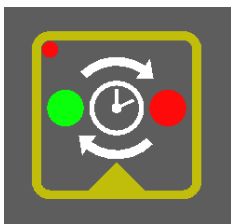

How to Use the Wash System

- **Press the power button to turn the oven on.**

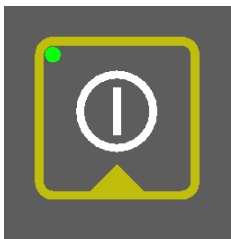

- **Set the oven to wash mode.** Turn the handle on the cook/wash control box to the right.

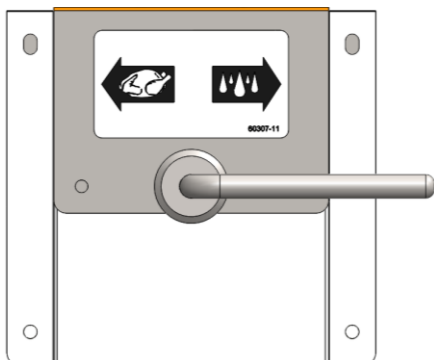

OPERATION (Part 5 of 6)

- Remove all cooked product from the oven along with any meat, bones or other debris from the oven interior. **Press the wash button and select your desired wash mode.** The oven will automatically start in the 1X (normal) wash mode. To activate the 2X (heavy) wash mode, press the wash button once. Repeated presses will toggle between 1X and 2X modes.

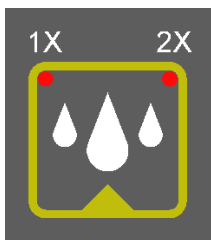

Once a wash mode has been selected, a pump within the oven will automatically draw soap from the soap container. If the soap container is empty, an alert will sound.

After drawing soap, the oven automatically adjusts its temperature to the optimal soap-activation temperature. It is normal for the oven to appear to be inactive during this temperature-adjustment step. When the oven has reached optimal temperature, the spray arm will briefly douse the interior with a premixed soap-and-water solution. The solution will soak for a period of time to allow it to react with the fat residue inside the oven. At the end of the soak cycle, the oven will automatically rinse.

Next, the oven will repeat the steps already outlined. They are (1) a soap step where soap is drawn from the soap bottle, (2) a douse step where the interior is sprayed with a soap-water solution, (3) a soak step where the solution is allowed to soak into and attack fat residue and (4) a rinse step where the soap solution is rinsed away with water. A final rinse ends the wash cycle. When the wash cycle has completed, the oven will automatically shut off.

- After washing, remove the drip plates.** The plates hang loosely inside the oven. No tools are required for this step. Do not be concerned if cooking residue remains on the plates; it will be loose and will come off easily. It is recommended that residue be scraped with a plastic (non-metal) scraper into a disposing receptacle before washing with regular dish-washing soap and warm water. For easier removal, hand-turn the spray arm as shown.

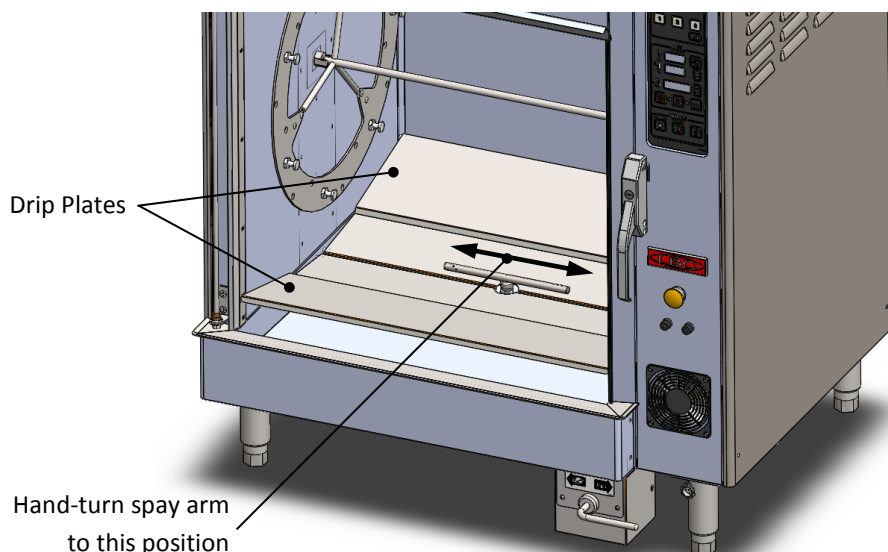

OPERATION (Part 6 of 6)

- After removing the drip plates, **inspect the grease catch pan and drain screen**. Both are located under the drip plates. Remove any product debris that may have accumulated in these areas.

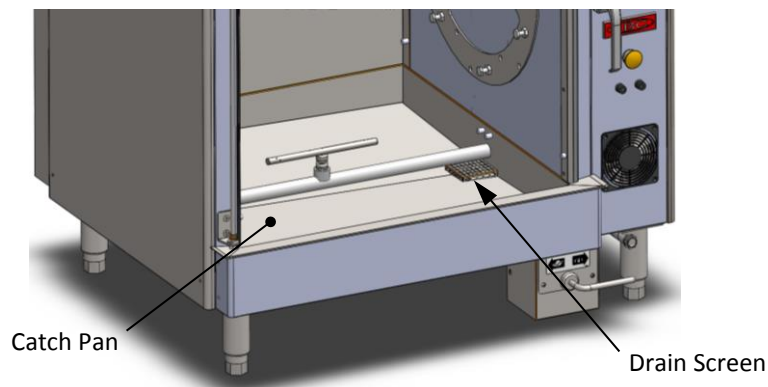

- **Clean the remainder of the oven interior** with warm, soapy water and a soft rag and replace the drip plates.
- **Once weekly (minimum), remove the fan guard and ceiling panel and clean the upper and lower surfaces.** Both parts are located at the inner ceiling of the oven and are retained with thumb nuts.

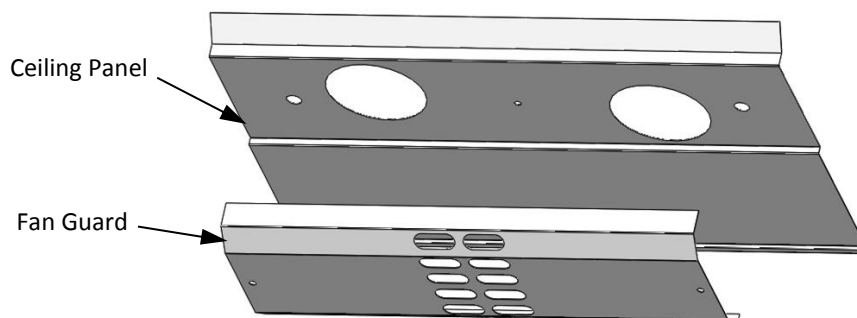

MAINTENANCE



WARNING

KEEP WATER AND SOLUTIONS OUT OF CONTROLS. NEVER SPRAY OR HOSE CONTROL CONSOLE.



CAUTION

ALWAYS KEEP THE AREA NEAR THE APPLIANCE FREE FROM COMBUSTIBLE MATERIALS.



CAUTION

KEEP THE FLOOR IN FRONT OF THE APPLIANCE CLEAN AND DRY. IF SPILLS OCCUR, CLEAN THEM IMMEDIATELY TO AVOID THE DANGER OF SLIPS OR FALLS.



NOTICE

Never use chlorine-based cleansers on this appliance. Chlorine corrodes stainless steel.

NOTICE

To maintain optimum safety and performance, it is recommended that a program of regular maintenance be implemented. It is the sole responsibility of the user to establish, schedule and enforce such a program. Although the actual service schedule will vary depending on the environment in which the equipment is operating, it is recommended that the above be done by an LBC-authorized service representative every six months.

After Each Use

- Remove all skewers or baskets from the carousel. Wash them with warm water and soap and rinse with water.

Daily

- Inspect the oven interior – including under the drip plates – for parts of chickens that may have dropped during the cooking process and dispose them.
- With the loading door open, hinge the inner glass frame outward for cleaning. **Do not use abrasive cleaners or wash pads as abrasives will damage the low-energy coating.**
- Use the automatic wash system. The Operation section of this manual includes instructions on how to use the wash system. The Operation section (see How to Use the Wash-Down System) also includes detailed instructions for after-wash cleaning.

Weekly (Minimum)

- Clean the ceiling panel and fan guard. Clean upper and lower surfaces. Both parts are located at the inner ceiling of the oven and are retained with thumb nuts for easy removal. The Operation section of this manual (see How to Use Wash-Down System) includes detailed instructions for this step.

As Needed

- Empty the grease receptacle to ensure it does not overflow.
- Replace the soap bottle when empty. Use only CIP Oven Cleaner, which can be purchased from LBC Bakery Equipment. See the Parts List section of this manual.



WARNING

CLEANER IS CORROSIVE. CAREFULLY READ PRECAUTIONS AND FIRST AID INFORMATION ON CONTAINER LABEL.



PARTS LIST



WARNING

BOTH HIGH AND LOW VOLTAGES ARE PRESENT INSIDE OF THIS APPLIANCE WHEN THE UNIT IS PLUGGED/WIRED INTO A LIVE RECEPTACLE. BEFORE REPLACING ANY PARTS, DISCONNECT THE UNIT FROM THE ELECTRIC POWER SUPPLY.



CAUTION

USE OF ANY REPLACEMENT PARTS OTHER THAN THOSE SUPPLIED BY LBC OR THEIR AUTHORIZED DISTRIBUTORS CAN CAUSE BODILY INJURY TO THE OPERATOR AND/OR DAMAGE TO THE APPLIANCE AND WILL VOID ALL WARRANTIES.



NOTICE

Service on this or any other LBC appliance must be performed by qualified personnel. For an approved service representative in your area, visit our website at www.lcbakery.com or call our factory toll free at 1-888-722-5686.

To order any of the parts or accessories listed below, visit our website at www.lcbakery.com. You may also call our factory toll free at 1-888-722-5686, or fax us at 1-425-642-8310, or email us at service@lcbakery.com.

Item No.	Part Description	Part No.	Comments
1	200W Interior Light	31603-88	
2	15A Fuse	30900-01	
3	CIP (Clean In Place) Oven Cleaner	72103-05	72103-05 is a carton of 2 each 2.5 gallon bottles of cleaner
4	Cap, Hose Attachment	72103-06	For CIP Oven Cleaner Bottle
5	Angle Spit	LCR7-SV	Stainless Steel
		LCR7-SV-C	Non-Stick Coating
6	Fork Spit	LCR7-SF	Stainless Steel
		LCR7-SF-C	Non-Stick Coating
7	Basket	LCR7-SB	Stainless Steel
		LCR7-SB-C	Non-Stick Coating
8	Chain Restraint Kit (Safety Tether)	72609-51	
9	Stand with Swivel Casters	LST7	
10	Water Filtration System	72610-48	
11	Scale Stick Filter	72610-48A	For Water Filtration System
12	Carbon Block Filter	72610-48B	For Water Filtration System



LIMITED WARRANTY

LBC Bakery Equipment ("LBC Equipment") has been skillfully manufactured, carefully inspected and packaged to meet rigid standards of excellence. LBC Bakery Equipment, Inc. (LBC) warrants products produced and sold by LBC and its duly authorized agents against defects in materials and workmanship within the following limitations:

What is Provided:

- Limited replacement parts as specified below, including standard ground shipping from LBC or service parts center when required.
- Limited labor for repair as specified below, including authorized service agent's transportation, portal to portal, up to one hundred (100) miles round trip and two (2) hours travel time.
- LBC, or an authorized service representative, will repair or replace, at LBC's sole discretion, any LBC equipment, including but not limited to the listed exclusions.

Coverage Period:

Extending from the date of shipment from LBC or its duly authorized dealer/distributor for the specified period:

- LRO and LMO Model Rack Ovens, LRP Model Rack Proofers, LRPR Model Retarder Proofers, LCR Model Rotisseries and LHC Model Holding Cabinets for a period of one (1) year limited parts and labor.
- Replacement parts shall be warranted for a period of ninety (90) days after installation by an authorized LBC service agent.

Conditions:

- Covered equipment must have been properly installed according to the requirements of the installation manual and all applicable local codes.
- The equipment shall not have been abused, misused or neglected or used for purposes other than intended by LBC.
- Water connected to the appliance shall have been in compliance with the following requirements:
 - Cold Water: 30 - 80 PSI
 - pH: 7 - 7.5
 - Conductivity: < 1/500,000 Ω per inch
 - Total Dissolved Solids: < 100 ppm
 - Hardness: 6.3 - 8.8 grains per gallon
 - Maximum Salinity and Ion content:
 - Chlorides: < 30 ppm
 - Sulfates: < 40 ppm
 - Iron: < 0.1 ppm
 - Copper: < 0.05 ppm
 - Manganese: < 0.05 ppm
- It is the responsibility of the purchaser to install and maintain the water supply to the appliance. Failure to provide satisfactory water quality in accordance with the operating manual requirements can cause damage to internal components and will VOID the warranty.
- All repair work is to be performed by an LBC authorized service agent.
- Equipment must be at the installation location of the original purchaser/user and shall not have been resold or reclaimed by another party.

Conditions (Continued):

- LBC equipment is for commercial use only. If sold as a component of another (OEM) manufacturer's equipment, or if used as a consumer product, such equipment is sold AS IS and without any warranty.
- Conditions of sale of the equipment shall have been met in full.
- The request for repair shall be made within the limited period of the warranty.
Failure to meet the above conditions will void this warranty.

Exclusions:

This warranty does not cover the following:

- Routine general maintenance, or periodic adjustment.
- Thermostat calibration after the first 30 days of use.
- Glass, Lamps, Gaskets, Oven Racks and other consumable parts.
- Air and gas burner adjustments.
- Fuse replacement.
- Cleaning and adjusting burners and pilot burners.
- Rack oven shutter adjustments.
- Repairs adjustments and corrections in the refrigeration portion of retarder/proofers resulting from the improper installation.
- Retightening of screws and fasteners.
- Failures caused by erratic or inadequate electrical, water, ventilation or gas service.
- Unauthorized repairs.
- Premature rusting, corrosion, or mineral build up caused by incoming water.
- Attached water treatment systems.
- Expedited freight on replacement parts other than standard ground shipments.
- Ordinary wear and tear.
- Use of the equipment for purposes other than those intended including non-commercial use such as residential or domestic.
- Appliances installed outside the contiguous U.S., including Alaska and Hawaii, and Canada.
- Incidental costs, charges, loss of business and damages as incurred by the user or others as a result of the use or failure of the equipment.
- Work and workmanship of the authorized service agent or others in the repair of the equipment.
- Other failures that are beyond the reasonable scope of this warranty.
- Damage caused during shipment is to be reported to the carrier, is not covered under this warranty, and is the sole responsibility of the purchaser/user.
- Natural disaster.

This warranty is exclusive and in lieu of all other warranties, expressed or implied, including expressed or implied warranties of merchantability or fitness for a particular purpose, each of which is hereby expressly disclaimed. The remedies described herein are exclusive and in no event shall LBC be liable for special, consequential or incidental damages for the breach or delay in the performance of this warranty