

MODELS LMO Max-E & LMO Max-G

ROTATING RACK OVEN

INSTALLATION and SERVICE MANUAL

GAS OVENS: POST IN A PROMINENT LOCATION, THE INSTRUCTIONS TO BE FOLLOWED IN THE EVENT THE SMELL OF GAS IS DETECTED. THIS INFORMATION SHALL BE OBTAINED FROM THE LOCAL GAS SUPPLIER.

RETAIN THIS MANUAL FOR FUTURE REFERENCE.

LBC BAKERY EQUIPMENT, INC.

6026 31st Ave NE
Tulalip, WA 98271, USA
Toll Free: 888-722-5686 (888-RACKOVN)
E-mail: sales@lcbakery.com
www.lcbakery.com

READ FIRST (Part 1 of 2)

ALL OPERATORS OF THIS EQUIPMENT MUST BE OF LEGAL AGE TO OPERATE SUCH EQUIPMENT AND MUST BE FAMILIAR WITH AND UNDERSTAND ALL CAUTION LABELS.

READ, UNDERSTAND AND FOLLOW THE INSTRUCTIONS AND WARNINGS CONTAINED IN THIS MANUAL. IT IS THE RESPONSIBILITY OF THE OWNER/OPERATOR OF THIS APPLIANCE TO TRAIN, SUPERVISE AND AUTHORIZE ANY PERSON DESIGNATED AS AN OPERATOR. ALL OPERATORS MUST READ AND UNDERSTAND THIS MANUAL.

IMPORTANT

GAS OVENS: IN THE EVENT A GAS ODOR IS DETECTED, SHUT DOWN UNIT AT MAIN SHUTOFF VALVE AND CONTACT YOUR LOCAL GAS COMPANY OR GAS SUPPLIER FOR SERVICE.

FOR YOUR SAFETY

DO NOT STORE OR USE GASOLINE OR OTHER FLAMMABLE VAPORS OR LIQUIDS IN THE VICINITY OF THIS OR ANY OTHER APPLIANCE.

WARNING

IMPROPER INSTALLATION, ADJUSTMENT, ALTERATION, SERVICE OR MAINTENANCE CAN CAUSE PROPERTY DAMAGE, INJURY OR DEATH. DO NOT OPERATE, CLEAN OR SERVICE THIS MACHINE BEFORE READING THIS MANUAL AND UNDERSTANDING COMPLETELY THE SAFETY INSTRUCTIONS FOUND HEREIN AND ON THE MACHINE'S LABELS.

IN THE EVENT OF A POWER FAILURE, DO NOT ATTEMPT TO OPERATE THIS DEVICE.

KEEP AREA AROUND THE OVEN CLEAR OF COMBUSTIBLES.

GAS OVENS: DO NOT OBSTRUCT COMBUSTION AND VENTILATION OPENINGS ON THE OVEN.

WIRING SCHEMATICS ARE LOCATED BEHIND THE APPLIANCE CONTROL PANEL IN CONTROL COMPARTMENT.

READ FIRST (Part 2 of 2)

WARNING

THIS APPLIANCE IS EQUIPPED WITH A THREE-PRONG (GROUNDED) PLUG FOR YOUR PROTECTION AGAINST SHOCK HAZARD. PLUG DIRECTLY INTO A THREE-PRONG RECEPTACLE. DO NOT CUT OR REMOVE THE GROUNDING PRONG FROM THIS PLUG.

WARNING

DISCONNECT FROM POWER SOURCE WHEN CLEANING AND/OR SERVICING THIS MACHINE.

WARNING

NEVER ATTEMPT TO CLEAN THIS MACHINE WHILE IT IS HOT OR HEATING AS RISK OF SERIOUS INJURY COULD RESULT.

WARNING

NEVER OPERATE THIS MACHINE WITH SAFETY COVERS OR INSPECTION PLATES REMOVED OR WITH SAFETY SWITCHES INOPERATIVE.

TABLE of CONTENTS

READ FIRST	2
GAS OVENS: LIGHTING & SHUTDOWN	5
ELECTRIC OVENS: SPECIFICATIONS	6
GAS OVENS: SPECIFICATIONS	8
SAFETY CONSIDERATIONS	9
RECEIVING	10
INSTALLATION	11
GAS OVENS: NATURAL/PROPANE GAS CONVERSION	15
STARTUP & INSPECTION	17
PRESSURE PANEL SETTINGS	20
CONTROL OPERATION & SETUP	21
DEFAULT PARAMETER SETTINGS	24
ILLUSTRATED PARTS BREAKDOWN	28
ELECTRICAL SCHEMATICS	36
LBC LIMITED WARRANTY	41

GAS OVENS: LIGHTING & SHUTDOWN

Lighting Instructions

After Long-Term Shutdown

1. Turn on the gas supply to the oven.
2. Open the gas valve access door located above the loading door. Switch the gas valve to "ON."

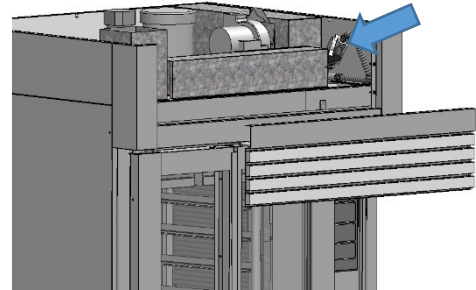

3. Keep the gas valve door open until the burner lights the first time.

WARNING
IF THE BURNER DOES NOT LIGHT, TURN OFF ALL GAS TO THE OVEN FOR 5 MINUTES AND THEN BEGIN AT STEP 1.

Daily Use

1. Press the "Power" button to turn the oven on. Close the oven door.
2. Set the oven temperature to the desired operating temperature by pressing the up or down arrow buttons next to the "Set Temperature" display.

Shutdown Instructions

Daily Use

Press the "Power" button to turn the oven off.

Long-Term Shutdown

Open the gas valve access door located above the loading door. Switch the gas valve to "OFF" and turn off the gas supply to the oven.

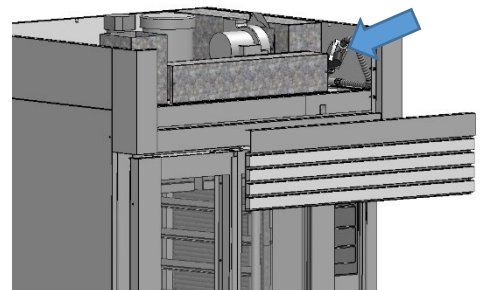
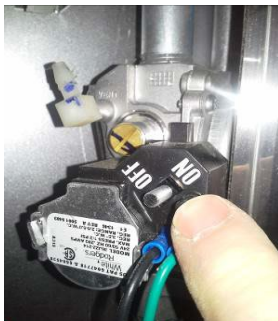

ELECTRIC OVENS: SPECIFICATIONS

Installation Requirements

- Oven ships fully assembled and will fit through a 36" door opening with removal of the oven door assembly, valence and back panel. Check local codes to determine if the oven needs to be installed under a hood.
- Clearance to Combustibles: 1" from back and sides, 18" from top
- Flooring: Appliance must be installed on a floor of noncombustible construction with noncombustible flooring and surface finish and with no combustible material against the underside thereof, or on noncombustible slabs or arches having no combustible material against the underside. Such construction shall in all cases extend not less than 12" beyond the equipment on all sides.

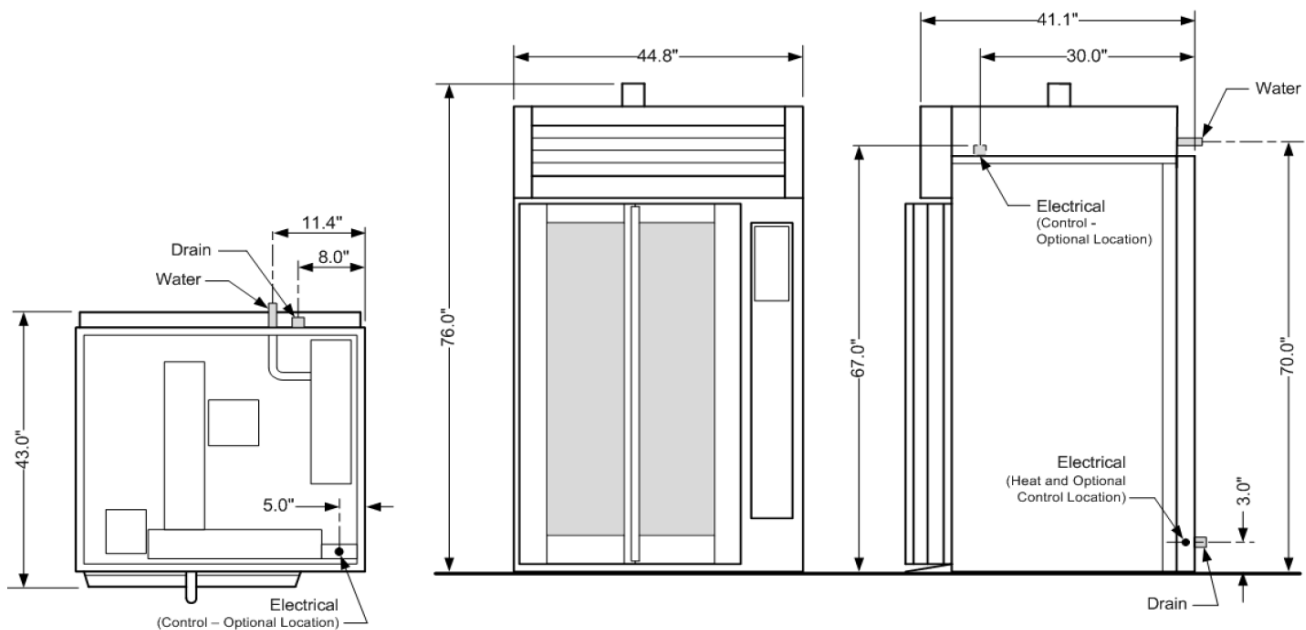

Water Quality Requirements

Parameter	Value	Parameter	Value
Alkalinity	< 22 ppm	Magnesium	< 0.65 ppm
Aluminum	< 17 ppb	pH	8.5
Calcium	< 3.3 ppm	Sodium	< 8.5 ppm
Free Chlorine Radical	< 0.6 ppm	Total Hardness	< 11.9 ppm

Utility Requirements

Total kW	Voltage, ph, Hz	MCA	MOP	Water	Drain
24.0 (Heaters)	208V, 3ph, 60Hz	85	100	1/2"NPT, cold water, 3 gpm @ 45 psi min	3/4"NPT, route to air gap drain
	240V, 3ph, 60Hz	75	85		
	480V, 3ph, 60Hz	35	55		
0.7 (Control)	120V, 1ph, 60Hz	15	15		

GAS OVENS: SPECIFICATIONS

Installation Requirements

- Oven ships fully assembled and will fit through a 36" door opening with removal of the oven door assembly, valence and back panel.
- Clearance to Combustibles: 1" from back and sides, 18" from top
- Flooring: Appliance must be installed on a floor of noncombustible construction with noncombustible flooring and surface finish and with no combustible material against the underside thereof, or on noncombustible slabs or arches having no combustible material against the underside. Such construction shall in all cases extend not less than 12" beyond the equipment on all sides.

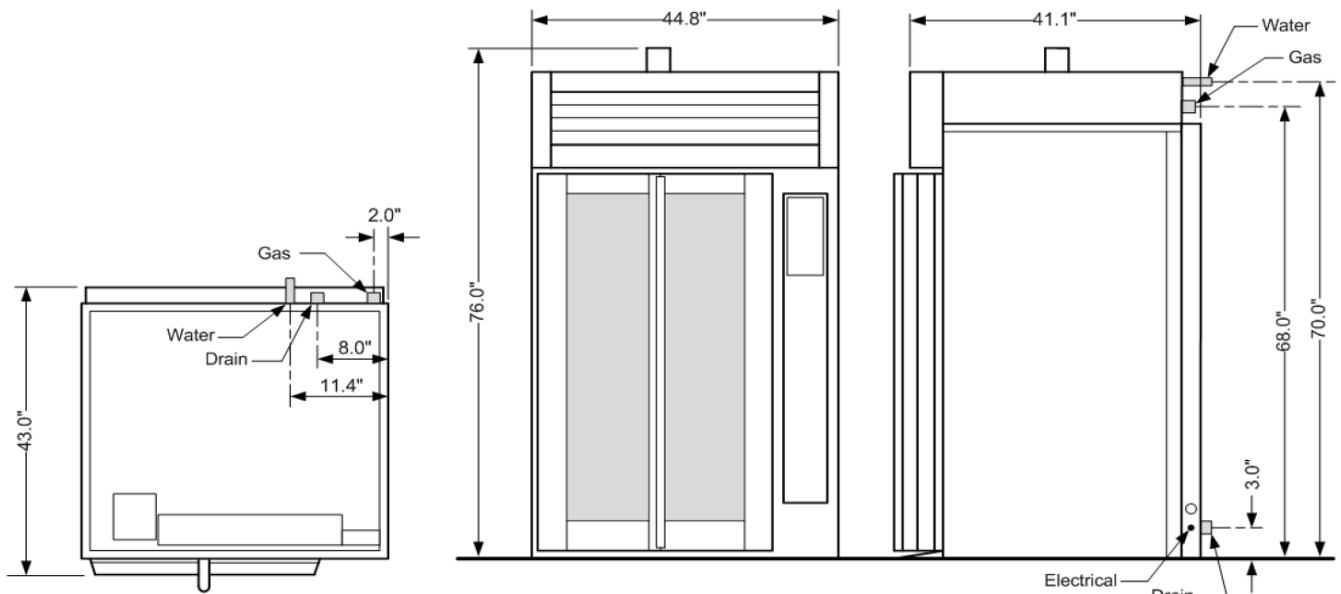

Water Quality Requirements

Parameter	Value	Parameter	Value
Alkalinity	< 22 ppm	Magnesium	< 0.65 ppm
Aluminum	< 17 ppb	pH	8.5
Calcium	< 3.3 ppm	Sodium	< 8.5 ppm
Free Chlorine Radical	< 0.6 ppm	Total Hardness	< 11.9 ppm

Utility Requirements

Electric	Gas	Water	Drain
120V, 15A, 60Hz dedicated circuit; NEMA 5-15R receptical required	1/2"NPT connection, 125 kBTU/hr, supply pressure = 5 - 14 inwc	1/2"NPT, cold water, 3 gph @ 45 psi min	3/4"NPT, route to air gap drain

SAFETY CONSIDERATIONS

Your LBC Bakery Equipment oven was manufactured to rigid standards. The oven is ETL listed as a unit, and meets applicable safety standards.

- A) **The responsibility of the manufacturer** is to supply suitable, comprehensive instructions and recommendations for operation and maintenance of appliance.
- B) All operations, maintenance and repair of oven must be performed by properly trained and qualified personnel, and all operations, maintenance and repair must be performed in a diligent manner. It is the **responsibility of owner/operator** to ensure proper training and diligence of any person coming into contact with either oven or output (product, exhaust or otherwise) of oven. It is the **responsibility of owner/operator** to ensure oven is installed and operated in accordance with OSHA Standard 1910.263.
- C) A regular periodic program of cleaning, inspection and maintenance must be established and comprehensive maintenance records maintained. It is the **sole responsibility of user** to establish, schedule and enforce frequency and scope of these programs in keeping with recommended practice and with due consideration given to actual operating conditions.
- D) The units must be operated within limits which will not exceed working limits of any component.

CAUTION

THIS APPLIANCE WEIGHS MORE THAN 1000 LBS. FOR SAFE HANDLING, INSTALLER SHOULD OBTAIN HELP AS NEEDED OR EMPLOY APPROPRIATE MATERIAL-HANDLING EQUIPMENT (SUCH AS A FORKLIFT, DOLLY OR PALLET JACK) TO REMOVE THE UNIT FROM ITS PACKING MATERIALS AND MOVE IT TO THE PLACE OF INSTALLATION.

NOTE: IF REQUIRED, YOU CAN REMOVE THE INNER RIGHT WALL COVER AND REMOVE THE STEAMER MASS IN FOUR SECTIONS.

Upon receiving the appliance, immediately check for damage (both visible and concealed) and loss. **Visible damage must be noted on the freight bill at the time of delivery and signed by the carrier's agent.** Concealed damage or loss means damage or loss which does not become apparent until the merchandise has been uncrated. **If concealed damage or loss is discovered upon unpacking, make a written request for inspection by the carrier's agent within 15 days of delivery.** All packing material should be kept for inspection. **DO NOT return damaged merchandise to LBC Bakery Equipment, Inc.; you must file your own claim with the carrier.**

INSTALLATION (Part 1 of 4)

General Information

This appliance, when installed, must be electrically grounded in accordance with state and local codes, or in the absence of local codes, with the *National Electrical Code (ANSI/NFPA 70)* or the *Canadian Electrical Code (CSA C22.2 No. 3, latest edition)* as applicable.

The appliance requires some assembly by an authorized LBC trained service technician.

Do not enclose the top of the appliance to other construction. The top of the oven must be accessible for service and must not be enclosed or covered. This clearance may be gained by removing baffles, filters and other components, provided that removing the components does not create a hazard. Gas Ovens: The top of the oven must also be open and have adequate air supply for combustion.

WARNING

THIS APPLIANCE MUST BE INSTALLED WITH A MINIMUM OF 1 INCH CLEARANCE FROM SIDES AND BACK AND 18 INCHES CLEARANCE FROM THE TOP TO COMBUSTIBLE SURFACES.

WARNING

THIS APPLIANCE MUST BE INSTALLED ON A NON-COMBUSTIBLE FLOOR EXTENDING 12 INCHES BEYOND THE APPLIANCE, WITH NON-COMBUSTIBLE CONSTRUCTION UNDER THE FLOOR.

General Information – Gas Ovens

This appliance must be installed under a ventilation hood.

This appliance must be connected to a gas shutoff valve in accordance with *CSA 9.1-M97 – ANSI Z21.15-1997* and *Addenda CGA 9.1 a-2001 – Z21.15a-2001*, *Manually Operated Gas Valves for Appliance, Appliance Connector Valves and End Valves*.

The installation of this appliance must conform with local codes, or in the absence of local codes, with the *National Fuel Gas Code (ANSI Z223.1/NFPA 54)* or the *Natural Gas and Propane Installation Code (CSA B149.1)* as applicable, including:

- The appliance and its individual shutoff valve must be disconnected from the gas supply piping system during any pressure testing of that system at test pressures in excess of 1/2 psi.
- The appliance must be isolated from the gas supply piping system by closing its individual shutoff valve during any pressure testing of the gas supply piping system at test pressures equal to or less than 1/2 psi.

This appliance is configured to operate on natural gas or propane gas. A gas conversion kit is available for this appliance. See the name plate on the appliance to determine if the appliance is configured for natural gas or propane gas. For conversion instructions, see the “Natural/Propane Gas Conversion” section of this manual.

INSTALLATION (Part 2 of 4)

Uncrating and Moving

1. Move oven to area where it is to be installed. NOTE: If the oven is to be moved through a 36" door, see section directly below.
2. Disassemble crate. Use caution to avoid damage to oven with pry bars or nail removers.
3. Remove plastic wrap and padding from outside of oven. Remove components from inside of the oven.
4. Use a fork lift to lift oven off of shipping skid. Slide forks under outer wall of oven. **Do not lift at middle of oven floor.** As an alternate method, oven is equipped with lifting eyes on top. Connect a chain or lifting strap capable of lifting 2000 pounds to the two lifting eyes to raise oven off of skid. Place oven on floor close to its final location.

Moving the Oven through a 36" Doorway (contact LBC for detailed instructions)

1. Disassemble crate. Use caution to avoid damage to oven with pry bars or nail removers. Remove plastic wrap and padding from outside of oven. Remove components from inside of the oven.
2. Remove top access cover of oven. Remove four internal hex-head screws between the slats of forward valance, then tilt access cover forward and lift it out.
3. Open loading doors. Remove door latch cam follower.
4. Remove valance assembly by removing the four screws attaching it to side trim. Slide the valance forward.
5. Remove top trim.
6. Remove screw attaching magnetic reed door switch to front of oven above control. Allow switch to hang in position.
7. Remove door assembly.

WARNING

DOOR ASSEMBLY IS HEAVY. USE EVERY PRECAUTION TO AVOID PINCHING FINGERS. USE ASSISTANCE TO MOVE DOOR ASSEMBLY.

- a. Remove the two screws attaching the lower door hinge to the front of the oven on both doors.
 - b. Remove the screws connecting the oven floor to the threshold.
 - c. Remove the four screws connecting the door mechanism to the front of the oven at the top of the door assembly. **Use caution to keep fingers out of pinch points.**
 - d. Carefully move door assembly away from front of oven without tilting it. Wrap door assembly with stretch wrap, rope or tape to keep doors from opening or moving.
 - e. Prop door in a safe location. Make sure it will not fall.
8. Gas Ovens: Remove two screws from gas inlet pipe bracket at back of oven. Push gas pipe forward so it clears door opening.
 9. Remove power cord and rear panel from oven.
 10. Move the oven through doorway sideways. NOTE 1: Oven weighs more than 1000 lb. If required, you can remove inner right wall cover and remove steamer mass in four sections. NOTE 2: Oven floor can be removed if necessary to lift oven from the inside.
 11. Replace all components removed in steps 1 through 10.

INSTALLATION (Part 3 of 4)

Setting the Oven in Place

1. Locate the oven in final location. Refer to “Specifications” section of this manual, “Installation Requirements” notes, for clearance to combustibles specifications.
2. Confirm floor is non-combustible and is supported by non-combustible construction.
3. Confirm there are no buried electrical wires or conduit, pipes or other utilities beneath oven.
4. Level oven by installing stainless steel shims under four corners as required. NOTE: Keep oven directly on floor if possible.

Electrical Connections

Both electric and gas ovens require connection to 120 VAC, 15 amp dedicated service. Gas ovens are shipped with cord and plug. Do not tamper with or modify plug or ground connection on cord.

Electrical Connections – Electric Ovens

Oven electrical connection for heat circuit is located in electrical box in control compartment. A 1” conduit raceway is provided to a junction box in lower right rear of oven.

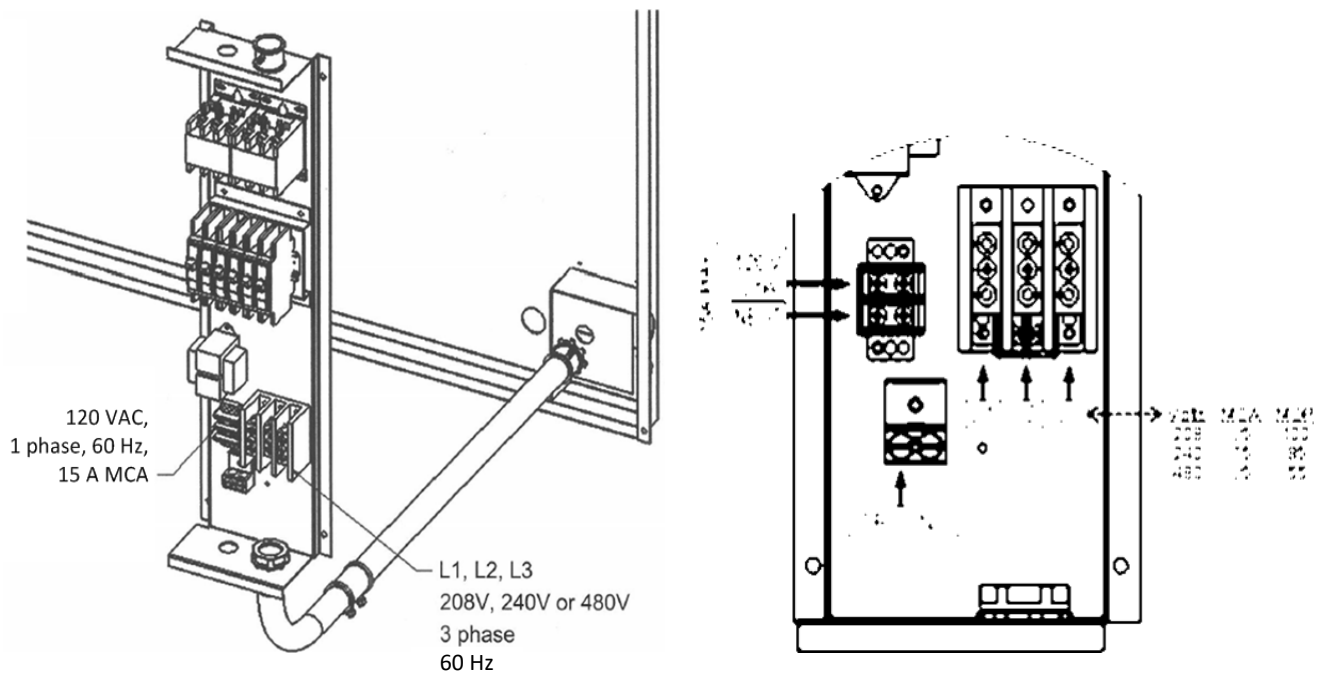

Gas Supply Specifications – Gas Ovens

1. Confirm available gas type is same as that stated on name plate of oven.
2. Confirm gas supply is regulated. Maximum pressure is not to exceed 14 inwc or 1/2 psi. Confirm supply is adequate for 125 kBtu per hour. Gas supply pipe should not be less than 3/4” NPT.
3. Confirm that an approved gas shutoff valve is installed before the appliance.
4. Connect gas supply to oven using an approved 3/4” gas supply connector. Use only sealant approved for gas connections.

INSTALLATION (Part 4 of 4)

Water Connection

This appliance must be installed with adequate backflow prevention in accordance with applicable federal, state and local codes.

1. Confirm availability of cold water near connection point on top of oven.
2. Confirm that there is a water shutoff valve within reach of connection point.
3. If necessary, install and connect a water treatment device at water supply connection downstream from water shutoff valve. An LBC water filtration assembly (no. 72610-48) with carbon block and scale stick cartridges is strongly recommended.
4. Connect water supply to the water solenoid valve on the top of the oven using an approved water connector.

Drain Connection

1. The drain fitting is 3/4" NPTM, located at the right rear corner of the oven.
2. Confirm that an air gap drain is available within 10 feet of the drain connection point.
3. Connect the drain line to the drain fitting using a hose or pipe suitable for connection to a drain and capable of handling 210°F water. The drain line should be 3/4" or larger and must slope 1/4 inch per foot to the drain.

Hood Interface

NOTE 1: Some locations require that the heat output of the oven be interlocked with the operation of the ventilation hood system. The heat circuit interlock connection is located at the electrical connection point in the front of the oven. To interlock the oven heat circuit to the hood, remove the jumper at wires 9 and 10 and connect to a dry contact connection. The interlock device should simply interrupt the 24 volts between wires 9 and 10. NOTE 2: The Commonwealth of Massachusetts requires that the flow of gas to the oven is interrupted when the hood ventilator is not operating.

Hood Ventilator Interlock
Connect point. Remove
This jumper and connect
The interlock here.

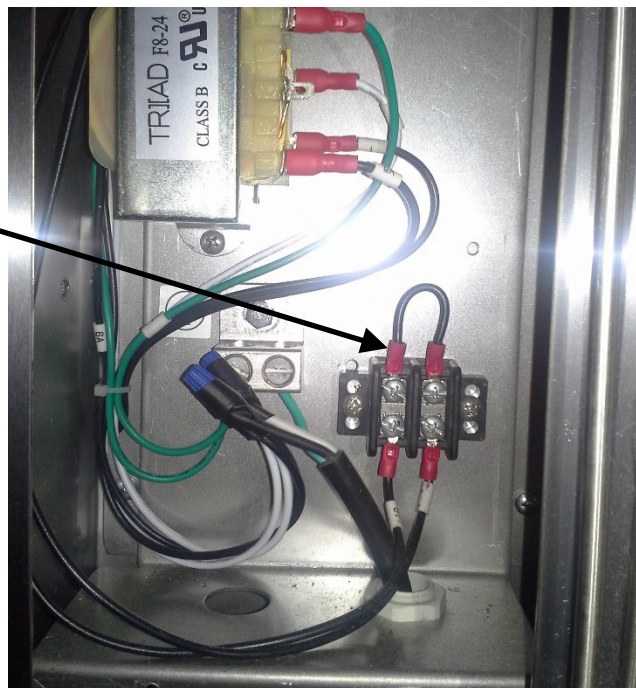

GAS OVENS: NATURAL/PROPANE GAS CONVERSION

(Part 1 of 2)

This oven was shipped configured to operate on either natural gas or propane gas. Consult the data plate to determine which fuel the oven is configured for.

The oven can be reconfigured for either natural gas or propane gas.

Gas Pressure

Both **natural gas and propane gas configurations have a manifold pressure setting of 3.5 inwc.** Do not change pressure regulator spring when making conversion. Always confirm gas pressure once conversion is complete.

To check manifold pressure, loosen set screw in manifold pressure tap. Install 1/4" hose from manometer on pressure tap. Read manifold pressure with burner on. Tighten set screw when manometer hose is removed.

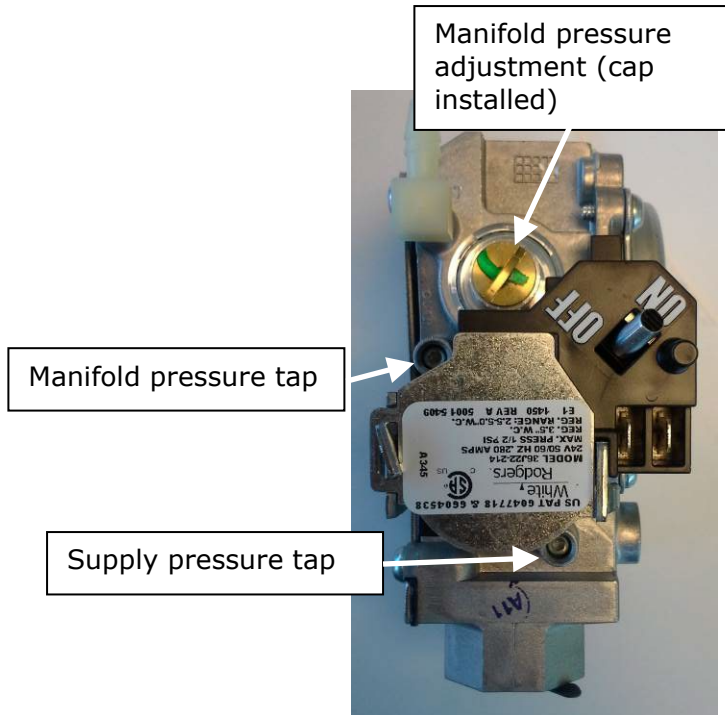

Burner Orifices and Exhaust Restrictor Plate

The orifices for each burner are different for natural gas and propane gas. The firing rate is 125,000 BTU/hr.

Natural Gas orifice is drilled and marked #49 and the restrictor plate is marked "NG".

Propane Gas orifice is drilled and marked #53 and the restrictor plate is marked "LP".

To Change Orifices

1. Turn off the gas supply to the oven at the wall.
2. Remove the burner cover from the top of the oven.
3. Disconnect the electrical wires at the front of the burner for the hot surface ignition and the flame sensor.
4. Disconnect the wires from the gas valve.
5. Disconnect the flexible gas line at the union located at the gas valve (see illustration).

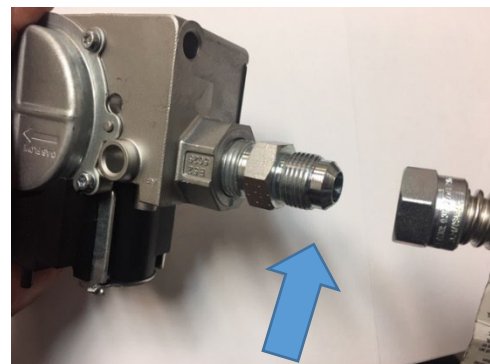

Disconnect gas Line here.

GAS OVENS: NATURAL/PROPANE GAS CONVERSION

(Part 2 of 2)

6. Carefully pull burner assembly up and out of top of oven. Use caution to avoid damaging the hot-surface ignitor and flame sensor on the burner.
7. Remove burners from burner assembly.
8. Remove and replace gas orifices. Clean any sealant or seal tape from orifice threads and manifold. Use only sealant approved for fuel gas.
9. Reassemble burner assembly.
10. Replace burner assembly in oven. Reconnect gas line, hot surface igniter wires and flame sensor wire.
11. Loosen the screws mounting the draft inducer to the exhaust collector box. Remove the top screw. Remove and replace the restrictor plate. Re-install the top screw and tighten all mounting screws. (Note: The hole in the restrictor plate must align with the center of the draft inducer inlet.)
12. Replace burner cover on top of oven.
13. Attach appropriate label provided on data plate to indicate conversion of burner.

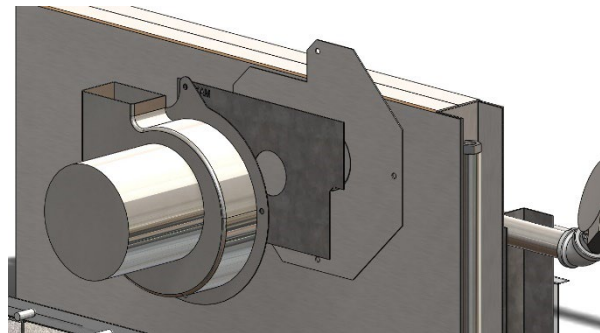
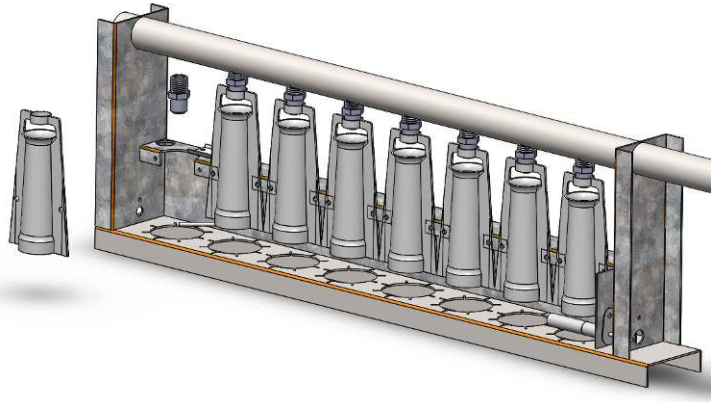

THIS OVEN IS
CONFIGURED FOR
NATURAL GAS

OR

THIS OVEN IS
CONFIGURED FOR
PROPANE GAS

14. Turn on gas supply to oven. Check for leaks.
15. Light oven. Refer to "Lighting & Shutdown" section of this manual.

STARTUP & INSPECTION

LMO-Max START-UP FORM: This form **MUST BE SIGNED & RETURNED** to LBC via Email to service@lbcbakery.com or FAX 425-642-8310, in order for the Customers Warranty to take effect

LMO-Max Rack Oven Inspection Procedure



Specifics	<u>Serial Number</u>	_____		
	Model Number	_____		
	Location Name	_____		
	Address	_____		
	City, State	_____		
Photos:	(Attach the following Photos to this inspection):			
	Any visible damage	_____		
	Data plate	_____		
	Power Connection in the oven connection box	_____		
	Water Supply (filter, RO system or softener)	_____		
	Gas Supply Pipe	_____		
Location Details:			AS FOUND	<u>If No., CORRECTED?</u>
	Oven on Non-combustible floor?	Y _____ N _____		
	Is the oven Level?	Y _____ N _____		
Oven Type:				
	Gas	Nat _____ Prop. _____		
	Electric (Voltage):	208 Volts _____ 240 Volts _____ 480 Volts _____		
Install Quality:				
	Supply voltages: Dedicated 120 VAC, 15Amp Max Rating	Y _____ N _____		
	Water Connection: No leaks? (Fig. 1)	Y _____ N _____		
	Gas Connection: No leaks? (Fig. 2)	Y _____ N _____		
	Drain Connection: Properly connected and			
	to an air-gap drain? (Fig. 3)	Y _____ N _____		
	If hood interlock is required; confirm proper connection and			
	hood power switch is properly labeled	Y _____ N _____		
Functional Check: Turn on power to oven.				
	Press power button on control. Unit turns on?	Y _____ N _____		
	Interior lights turn on when the door is opened?	Y _____ N _____		
	Roll in a rack and close loading door. Confirm:			
	Blower motor starts? (Audible)	Y _____ N _____		
	Rack starts to rotate. Wheels off the ground?	Y _____ N _____		

	Burner test:			
	Set to 125° F. (Temp starts to rise within a minute)?	Y _____	N _____	_____
		(If temp does not start to rise, Call LBC)		
	Supply side gas pressure when burner is running?	_____	WC	_____
		(If less than 5" and greater than 14", Call LBC)		
	Set to 300° F. Minutes to go from 150° to 250° F?	_____	Mins	
	Combustion Test:			
	Set to 350° F. Wait one minute:			
	<u>Check Carbon Monoxide for 1 minute.</u>	CO _____	PPM	
		<u>(If greater than 75%, Call LBC)</u>		
	Take Photo of CO Measurement.			
	Check sensor VOLTAGE at test point:	_____	VAC	
		(If Voltage is not between 3-6 VDC, call LBC)		
	Steam Test: Can you hear hear the solenoid open and water spraying? (Audible)	Y _____	N _____	_____
	Rack Stopping Position (Hot Oven):			
	Carrier Stops at the door when door is opened?	Y _____	N _____	_____
	Check Air-Gap settings on pressure panel.			
	Refer to settings in manual.	Y _____	N _____	_____

Final Inspection:				
	Loading doors open/close freely past 90° without obstruction	Y	N	_____
	Doors open 1/2" to 1" before motor and rack Stops?	Y	N	_____
	Gas is on?	Y	N	_____
	Electrical Is on?	Y	N	_____
	Water is on?	Y	N	_____
	Gaskets: Installed and seated correctly?	Y	N	_____
	No cracks or missing pieces?	Y	N	_____
	All screws and electrical are tight? (If not, tighten down firm)	Y	N	_____
	All plumbing connections are tight and do not leak.	Y	N	_____



Fig. 1



Fig. 2

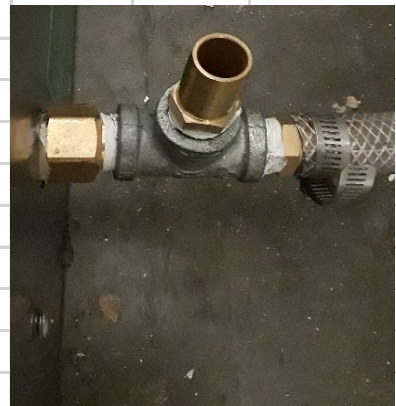

Fig.3

FOR TECHNICAL SUPPORT, CALL LBC: 888-722-5686 x1

Name: _____ Company: _____

Signature: _____

Date: _____

PRESSURE PANEL SETTINGS

Adjust gap between shutter side of air opening adjacent to adjusting screw.

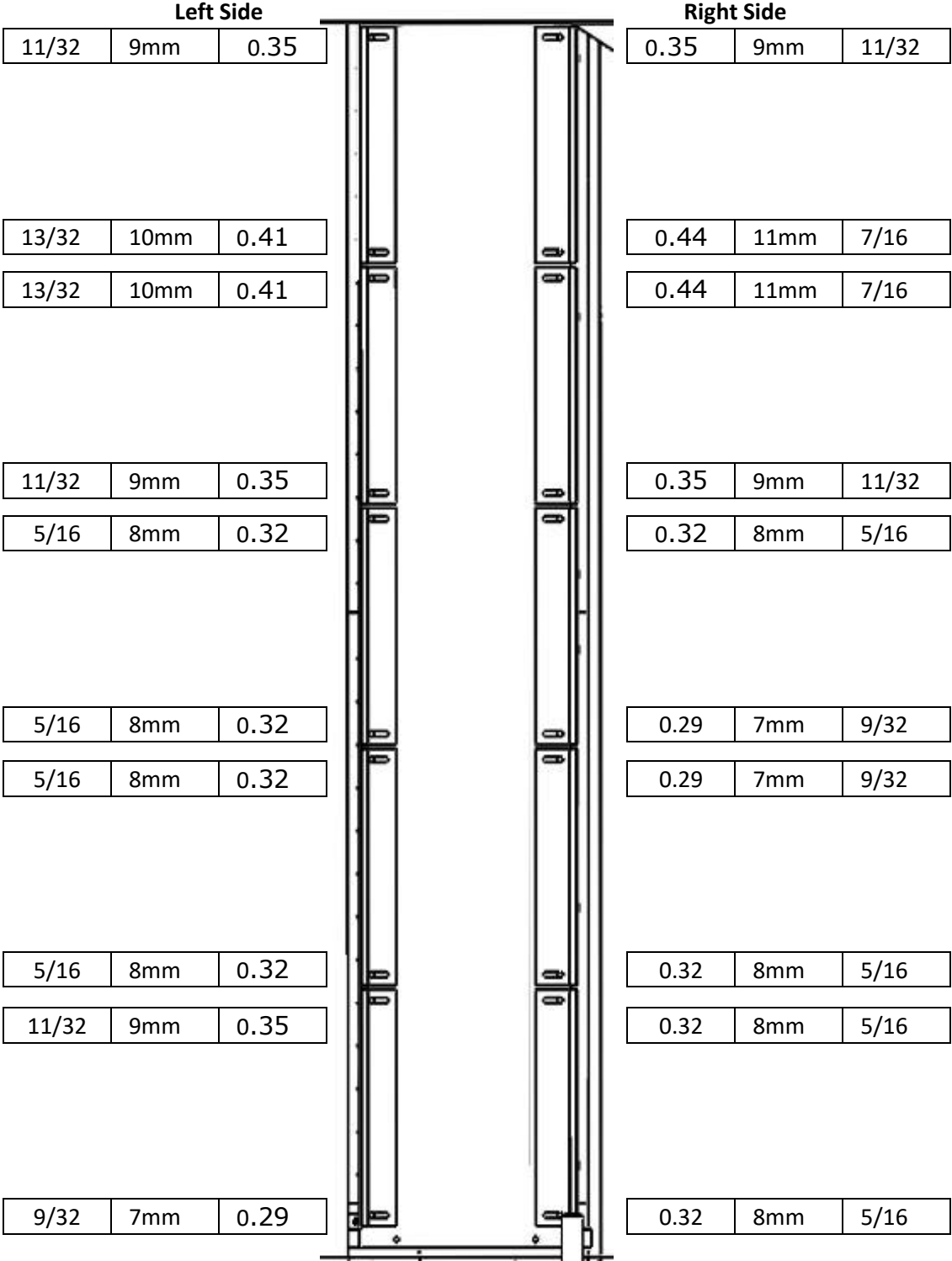

CONTROL OPERATION & SETUP (Part 1 of 3)

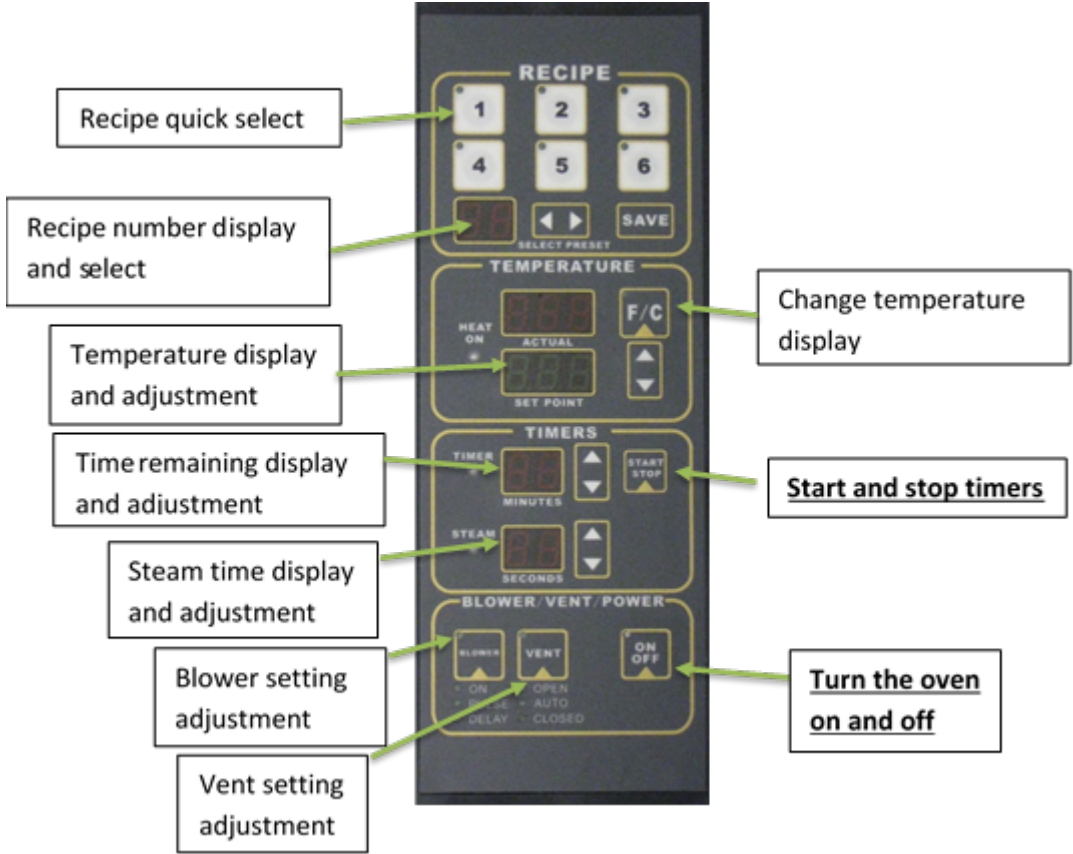

CONTROL SETUP (Part 2 of 3)

The oven control can be tailored to operate differently, depending on the customer. Here is a list of the configurable parameters:

- Sb – Temperature Set-back causes the control to reduce the thermostat setting when the oven is running, but not being used for more than a selected time. The oven is not being used when the door remains closed, and the timer is not running. Sb can be set to “On” or “OF”.
- St – Set-back Temperature determines what the thermostat will be when set-back occurs. It can also be set to “00” and cause the oven to turn off when the set-back time is reached. St is shown in 10-degree increments.
- Id – Idle delay is the selected time that the oven can be unused before set-back occurs. Id is shown in ten-minute increments and can be set for 10 minutes, up to 120 minutes.
- IL – Idle Illumination can be set to “On”, where the interior light and rack rotator will continue to operate when the door is closed and the oven is on, or to “OF”, where the interior light and the rack rotator will be off if the oven door is closed, and the timer is not running for more than 45 seconds.
- PL – Programming Limitation limits the user from accessing certain function and changing pre-set recipes. PL can be set to “On” to turn on the limits or “OF” to allow user access and recipe changes.
- FC – F or C temperature restrictions fixes the temperature display in Degrees “F”, Degrees “C” or allows the user to change the display when set to “B”.
- tP – Step Function; “On” allows the use of recipe steps. “OF” prohibits the use of recipe steps. Turning steps on or off requires that the entire recipe list must be re-written.
- T4 – The maximum steam time that the user can select is set from 1 to 99 seconds.
- T5 – Proportional Steam for user settings up to 59 seconds, in seconds ON for every 10 seconds. “01” will turn the water on for 1 second, then off for 9 seconds and then repeats. “10” turns the water on continuously until the user set steam time or the T6 limit is reached.
- T6 – Maximum total water that will be dispensed in a user set steam cycle set for up to 59 seconds is set in seconds.

- T7 – Maximum total water that will be dispensed in a user set steam cycle set for 60 to 99 seconds is set in seconds.
- T8 – Proportional Steam for user settings for 60 up to 99 seconds, in seconds ON for every 10 seconds. “01” will turn the water on for 1 second, then off for 9 seconds and then repeats. “10” turns the water on continuously until the user set steam time or the T7 limit is reached.
- T9 – Post steam delay is the length of time that the circulation blower will stay off at the end of a steam cycle in seconds.
- P5 – Power On Option determines if the oven will stay off or turn on when the electrical supply to the oven is connected. “UP” = on, “dn” = off.
- Temp Offset is a numeric value, positive or negative, that is added to the sensed temperature of the oven when it is displayed, limited to 36 degrees F or 20 degrees C. Increasing the value of this number will lower the temperature in the oven. Decreasing the value of this number will raise the temperature in the oven.

To access and adjust these parameters:

1. Press the power button to turn the oven off.
2. Press and hold the “F/C” button until the digital display shows “Sb” in the **TIME** display.
3. Continue holding the “F/C” button until all the parameters are set.
4. Press the **TIME** up and down buttons to scroll through the parameter. Press the **STEAM** up and down buttons to adjust the set value that is displayed in the STEAM time display.
5. Press the **TEMPERATURE SET-POINT** up and down buttons to adjust the temperature offset value.
6. Once the “F/C” button is released, the changes to the off-set and the parameters will be automatically saved.

Be sure to mark on the back of the control panel or in this manual any changes that you make to the parameters. This information will be needed if the control is ever replaced.

CONTROL OPERATION & SETUP (Part 3 of 3)

Temperature Calibration

1. Place the sensor of an electronic thermometer in the air distribution slot of the pressure panel. Locate the thermometer outside the oven, preferably with the sensor wire over the top door hinge. **Caution: Do not attempt to calibrate the thermostat to a tray thermometer.**
2. Heat the oven to operating temperature (350 to 425°F) and allow the oven to operate for at least 30 minutes at the set temperature with the door closed.
3. With the oven heated to set point, press the “Power” button to turn the control off.
4. Press and hold the temperature “F/C” button until the actual temperature and the offset value are displayed. Compare the displayed temperature to the temperature on the electronic thermometer.
5. Continue to hold the “F/C” button and press the temperature up or down buttons to adjust the offset value. The actual temperature display will adjust to show the recalibrated value. Match the temperature on the display with the temperature on the electronic thermostat.
6. Release the “F/C” button. Press the power button to turn the oven back on.
7. Check the calibration through two heat cycles.
8. Remove the thermometer sensor from the pressure panel air distribution slot.

DEFAULT PARAMETER SETTINGS

General Settings		LMO/Max
Sb	Set-Back	OFF
St	Set-back Temperature	25
Id	Idle Delay	9
IL	Idle Illumination	ON
PL	Programming Limitation	OF
FC	F or C restriction	_B
tP	Step Recipe	OF
t4	Maximum Settable Steam	30
t5	Proportional Steam, 1-59	10
t6	Maximum Water, 1-59	20
t7	Maximum Water, 60-99	20
t8	Proportional Steam, 60-99	10
P5	Power On Option	dn
t9	Post Steam delay	0

NOTES

ILLUSTRATED PARTS BREAKDOWN

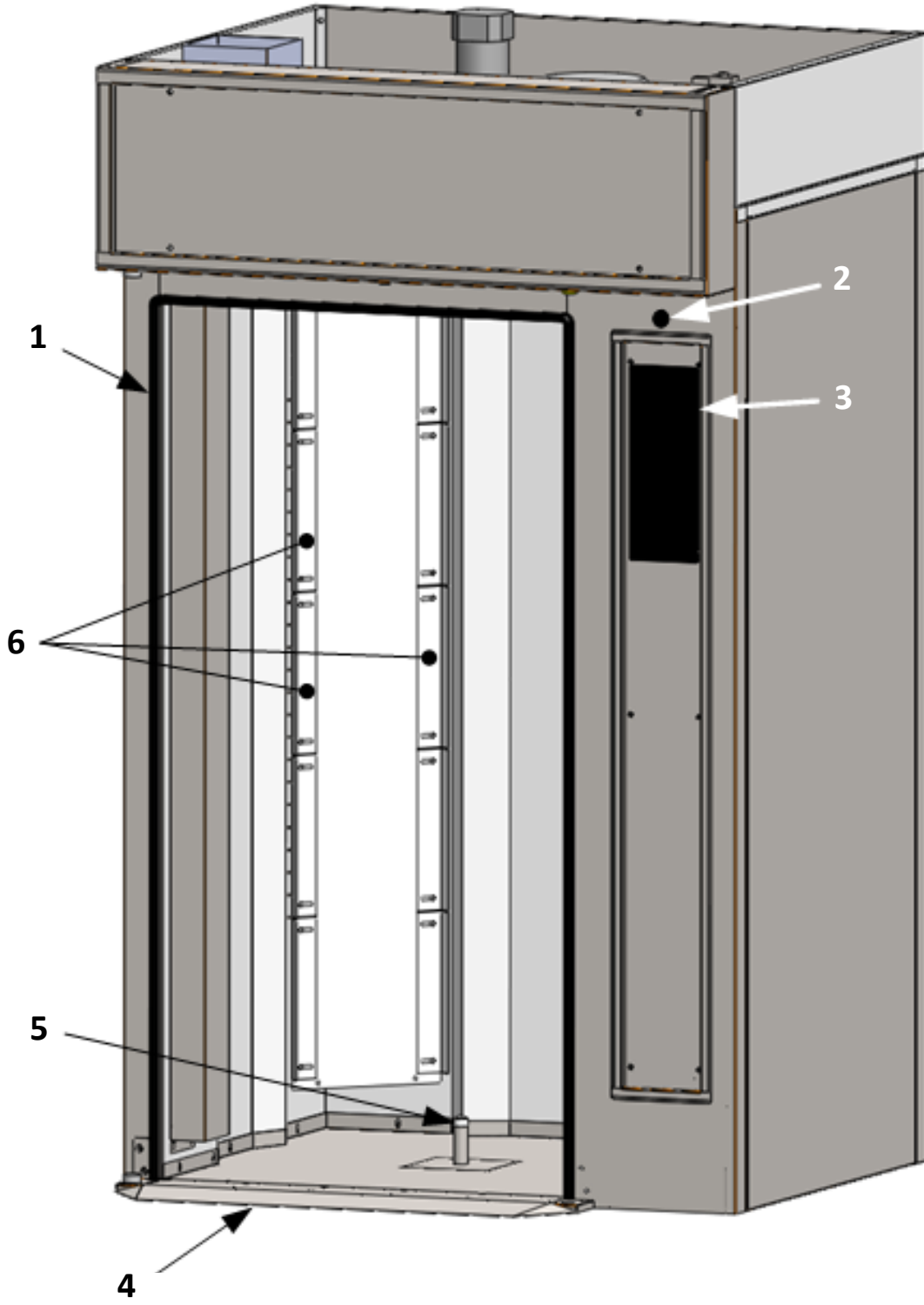

Oven – Front View

ILLUSTRATED PARTS BREAKDOWN (Part 2 of 10)

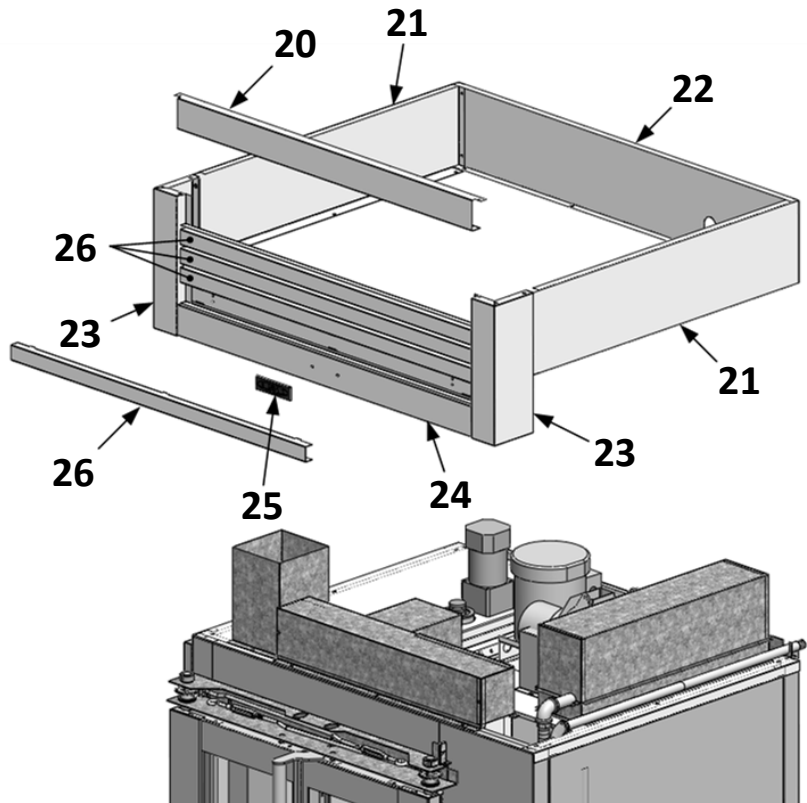

Top Trim

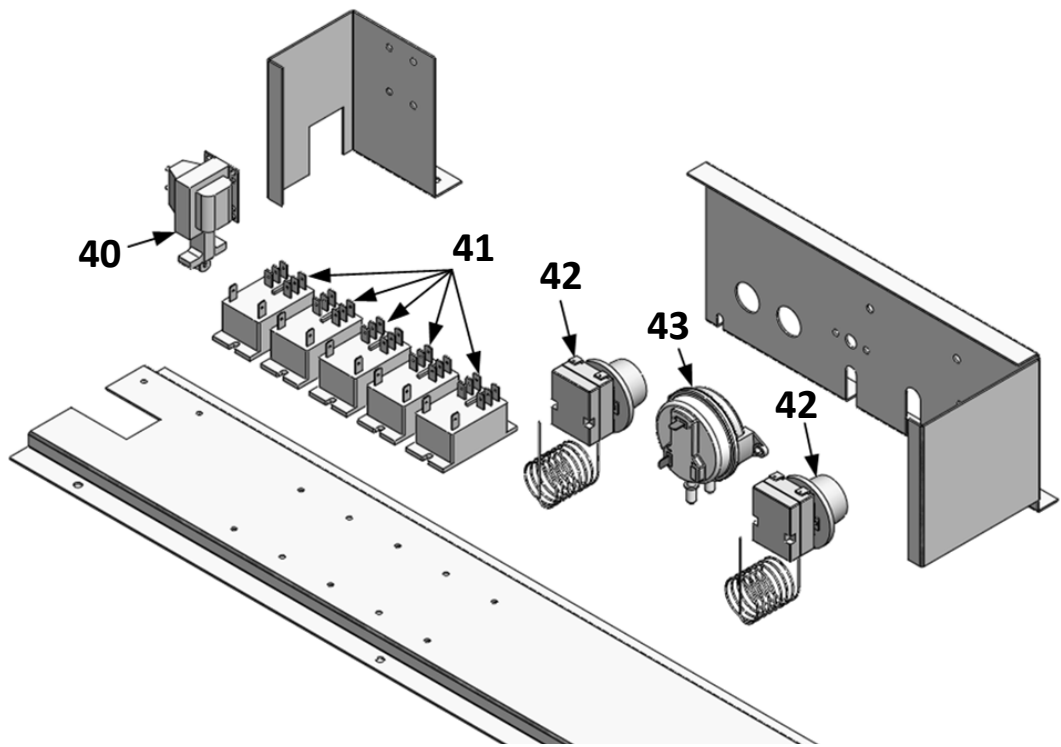

Control Box (Upper Front of Oven)

ILLUSTRATED PARTS BREAKDOWN (Part 3 of 10)

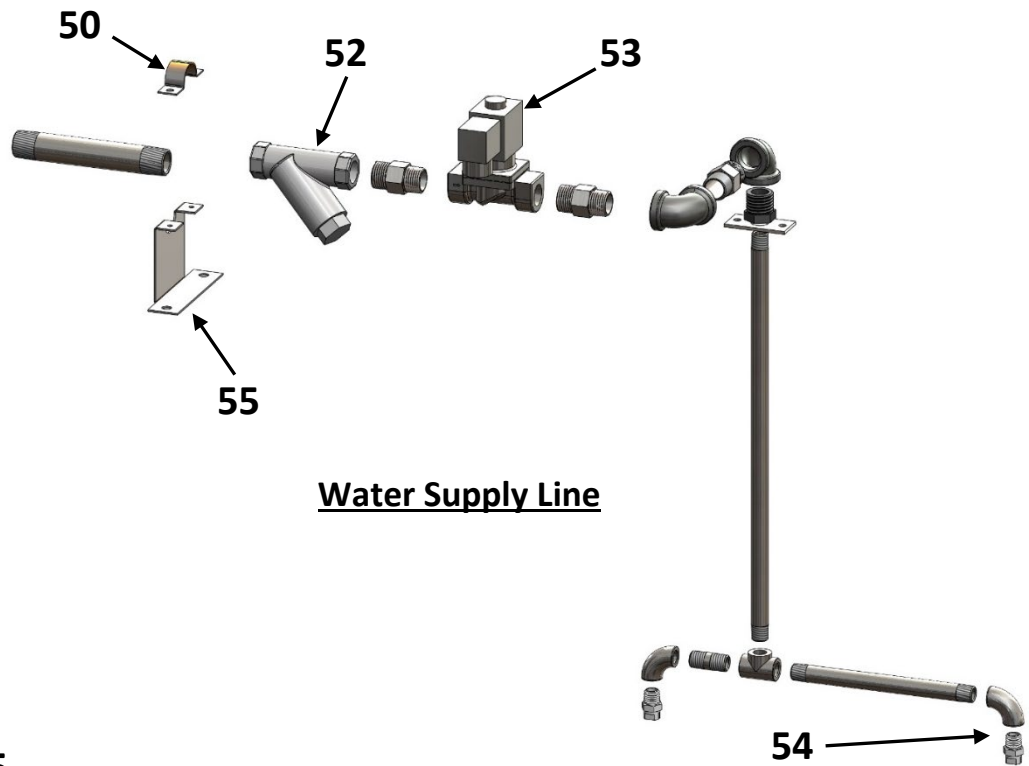

Water Supply Line

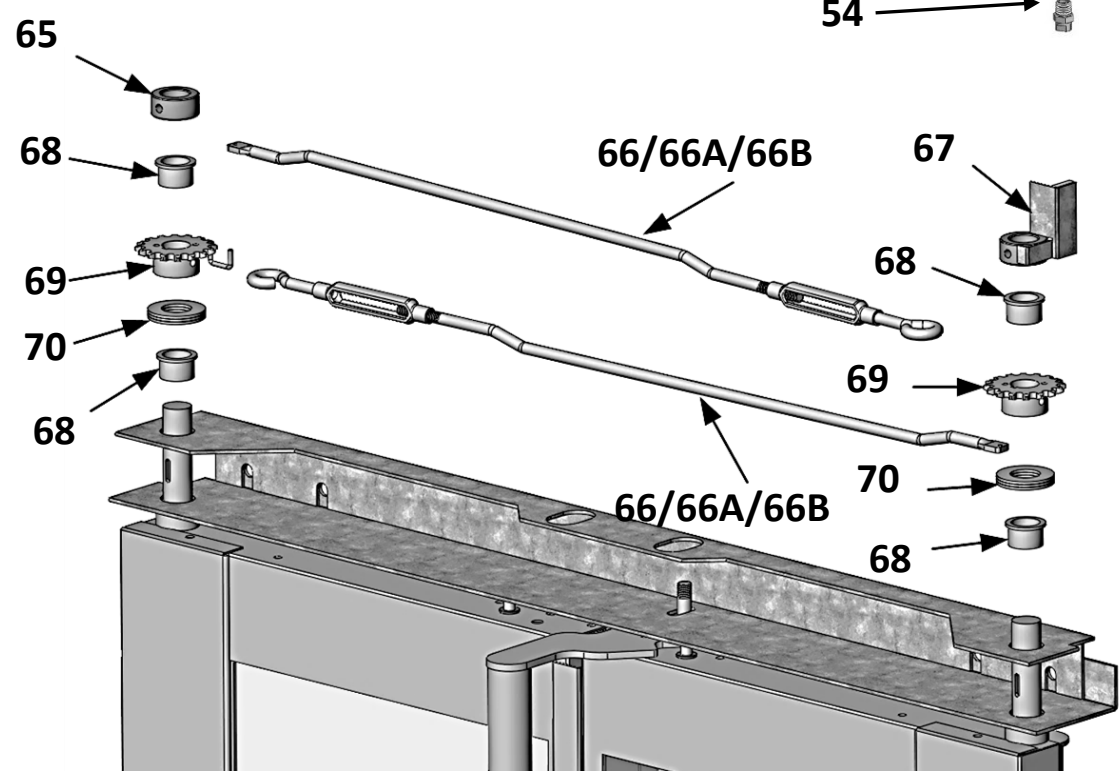

Door Closure Parts

ILLUSTRATED PARTS BREAKDOWN (Part 4 of 10)

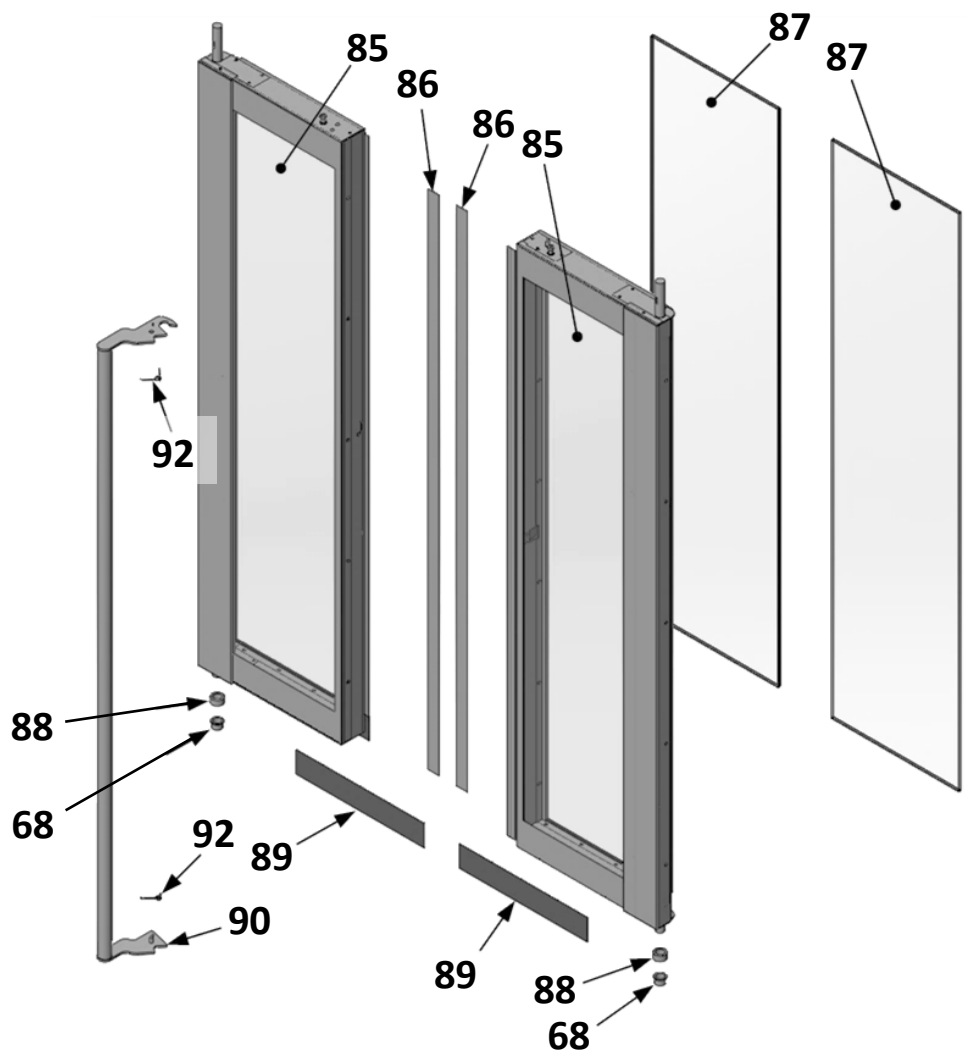

Loading Doors

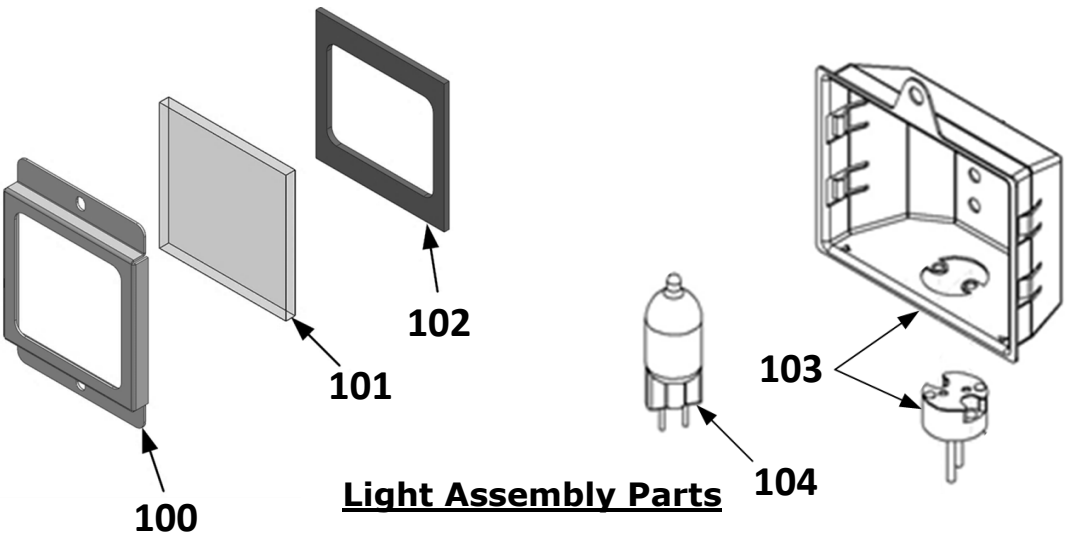

Light Assembly Parts

ILLUSTRATED PARTS BREAKDOWN (Part 5 of 10)

Rotation Assembly

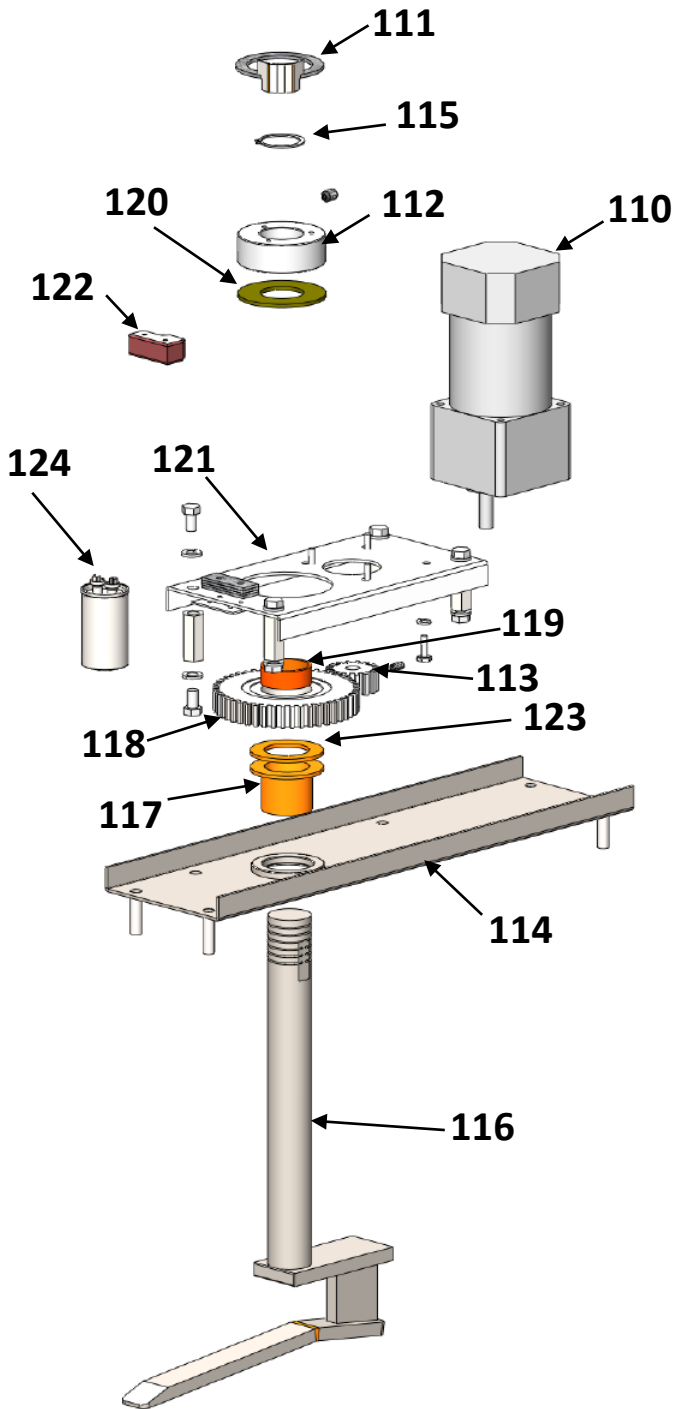

Blower Motor / Fan

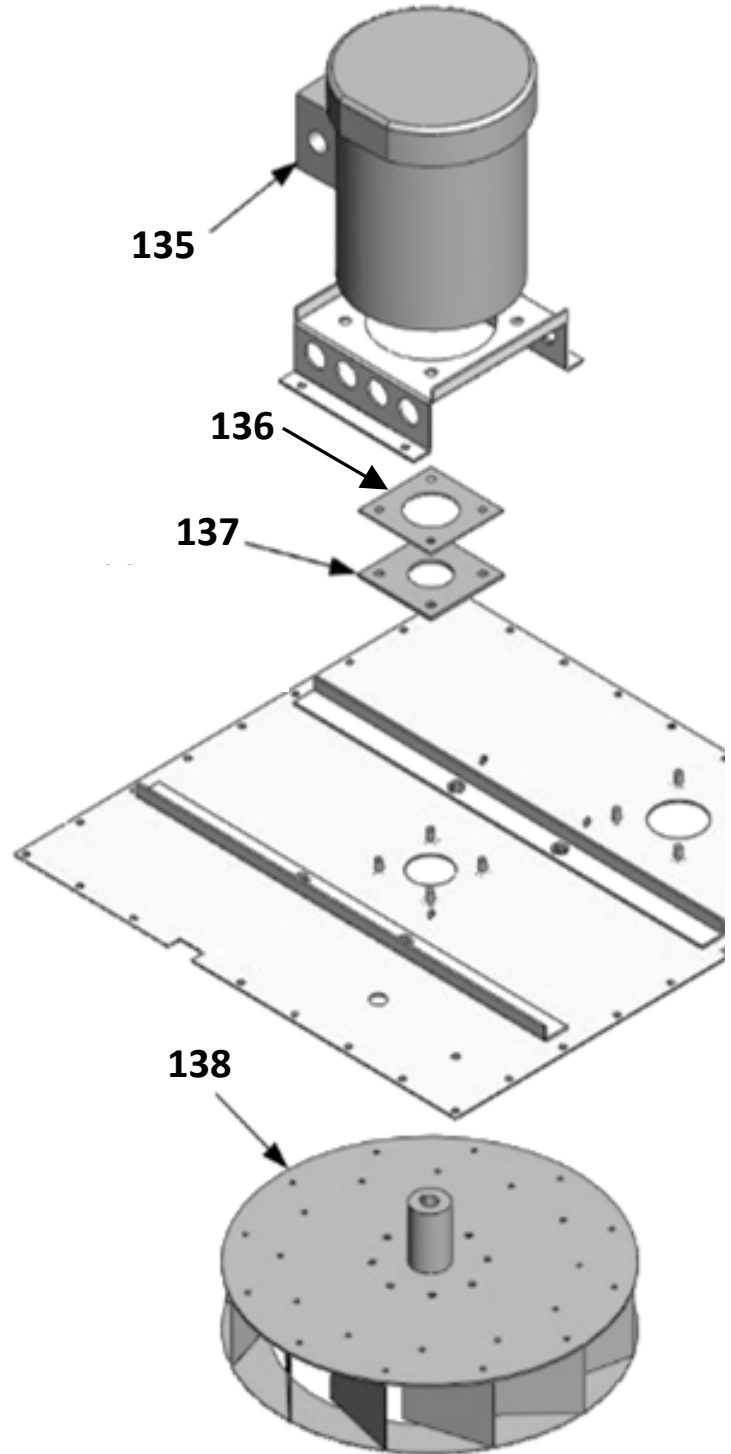

ELECTRIC OVENS: ILLUSTRATED PARTS BREAKDOWN ***(Part 6 of 10)***

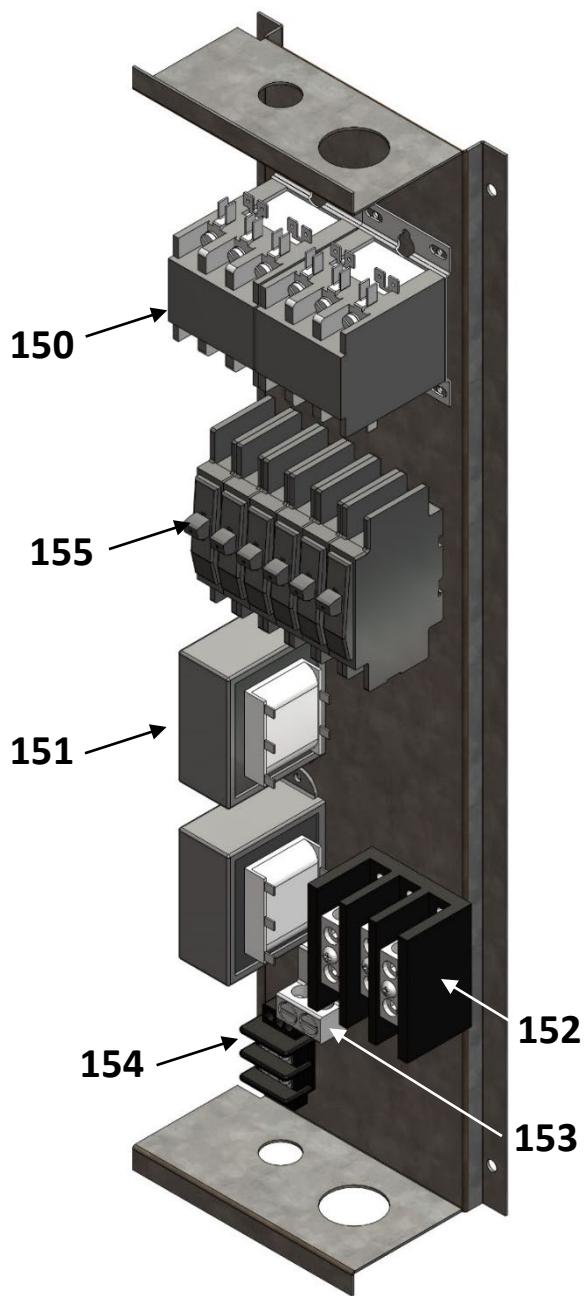

Control Box
(Behind Control Door)

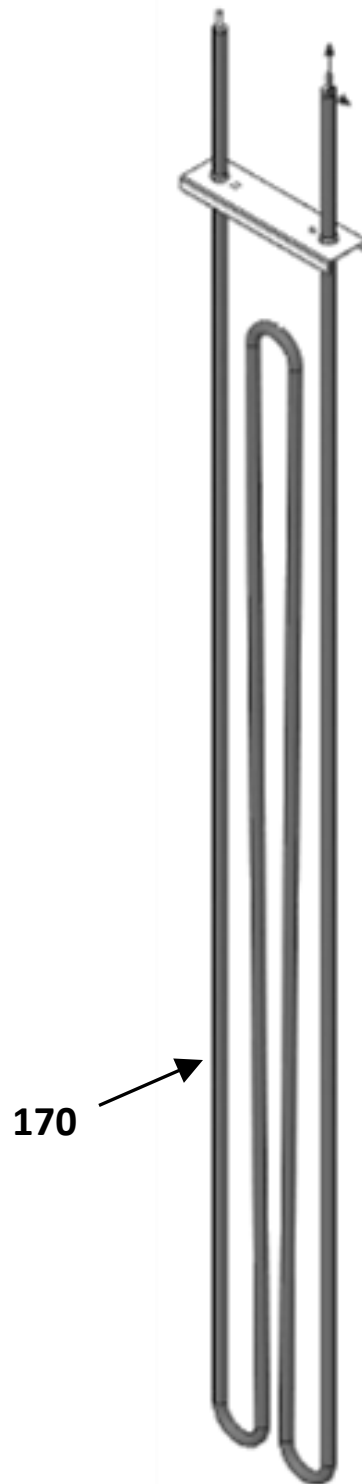

Heater Element

GAS OVENS: ILLUSTRATED PARTS BREAKDOWN (Part 7 of 10)

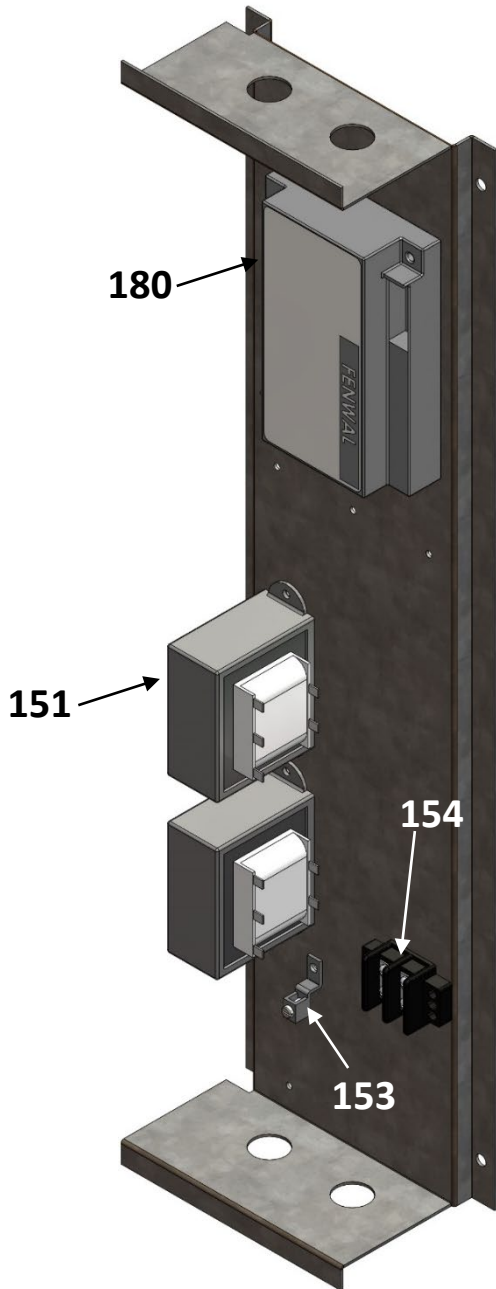

Control Box
(Behind Control Door)

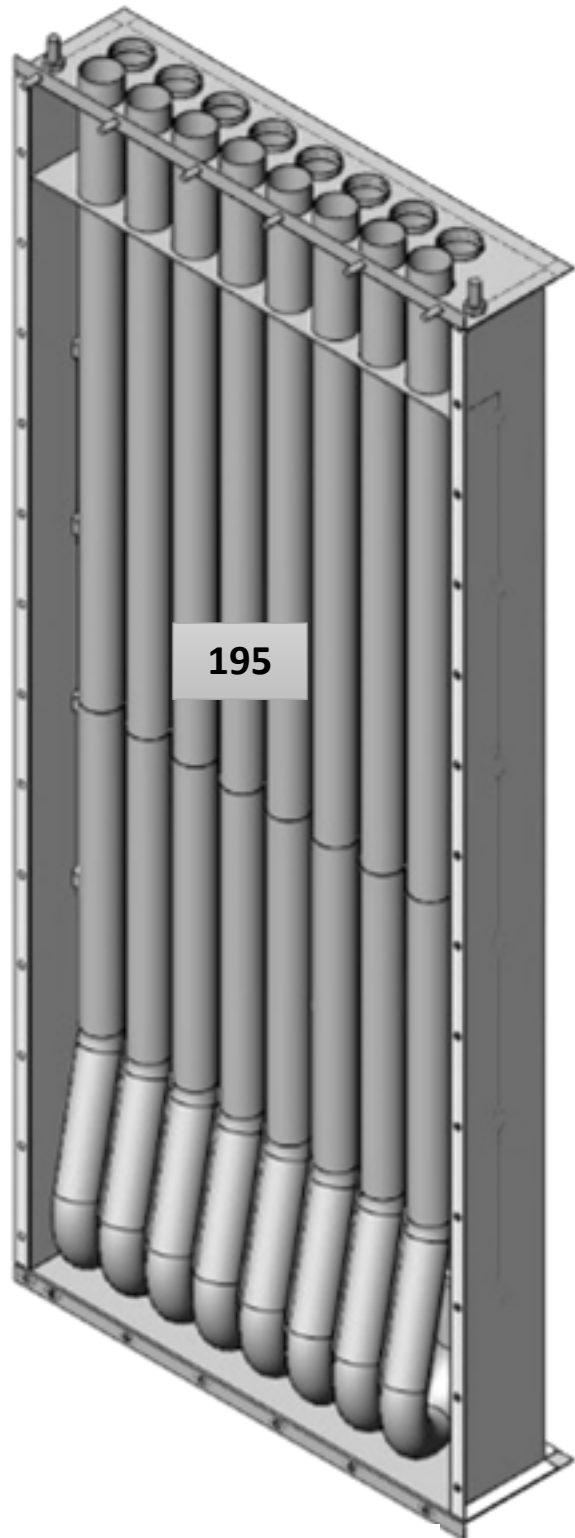

Heat Exchanger

GAS OVENS: ILLUSTRATED PARTS BREAKDOWN (Part 8 of 10)

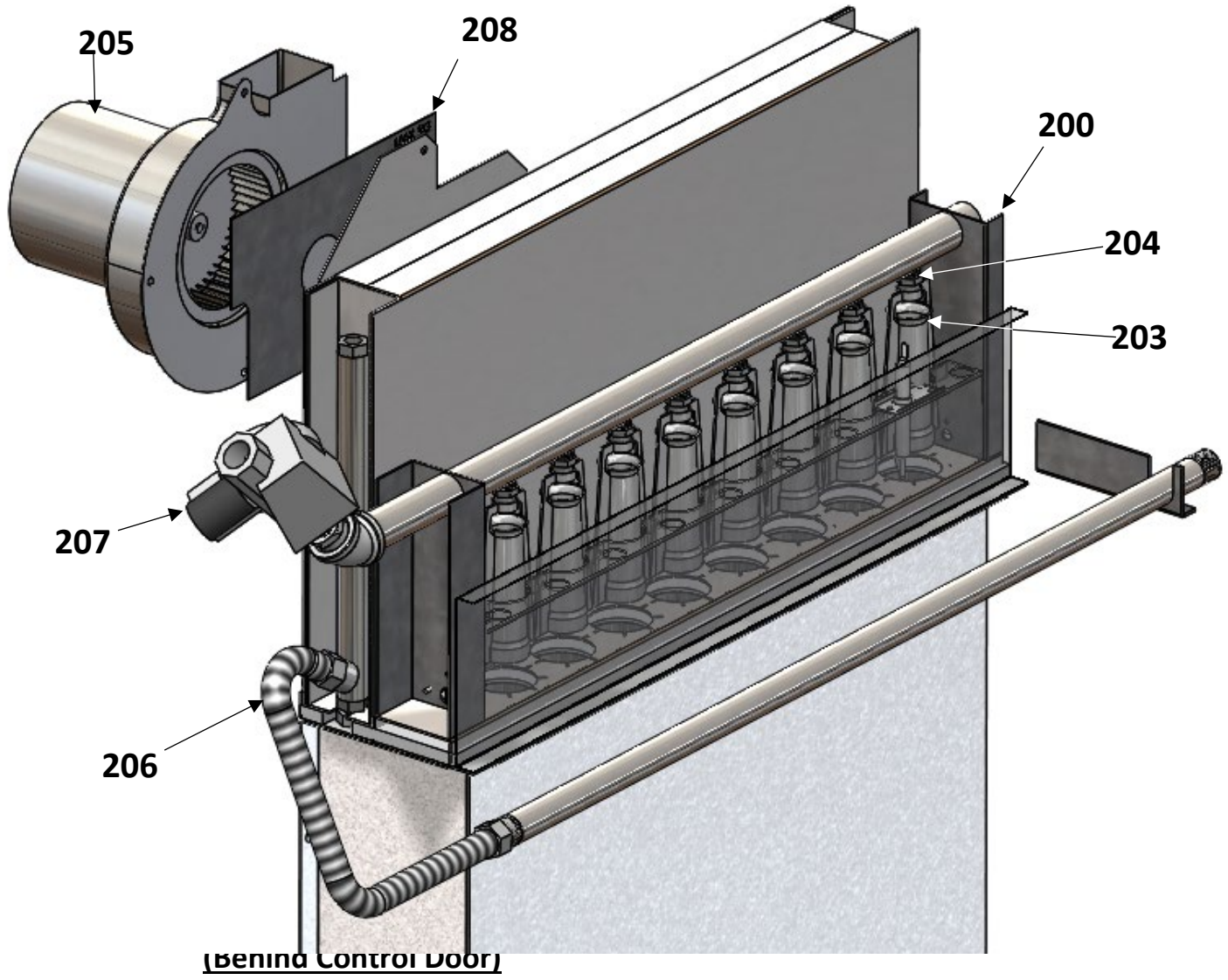

(Behind Control Door)



burner, Gas Supply, Exhaust

ILLUSTRATED PARTS BREAKDOWN (Part 9 of 10)

1	Door Gasket	1	72602-24-6	
2	Overheat Indicator	1	31600-19	
3	Main Control	1	40102-70	
4	Loading Ramp	1	151-574-1	
5	Bushing, Rack Pin	1	151-580-3	
6	Shutter, Pressure Panel	10	151-219M	
<hr/>				
20	Top Runner, Hood Face	1	151-507-3	
21	Side, Top Trim	2	151-260M	
22	Rear Panel, Top Trim	1	151-259-M	
23	Cover, Hood End	2	151-506	
24	Bottom, Valence	1	180-507-1	
25	Logo Plate, LBC	1	60301-162	
26	Louver, Valance	4	151-508	
<hr/>				
40	Solenoid, Laminated	1	70403-04-1	
41	Relay	5	30701-05	
42	Thermostat	2	30401-28	
43	Pressure Switch	1	30308-07	
<hr/>				
50	Clamp, Water Supply	1	151-541-1	
51	Check Valve	1	70404-08	
52	Strainer	1	73701-04	
53	Solenoid Valve	1	70403-03	
54	Spray Nozzle, Steamer	1	70101-77	
55	Support, Water Supply	1	151-541	
<hr/>				
65	Set Collar	1	70203-02	
66	Linkage Rod	2	151-504	
66A	M8 Turnbuckle	2		
66B	Chain	2		
67	Switch Magnet Assembly - Door	1	151-798	
68	Flange Bearing, Bronze	4	151-503	
69	Sprocket Weldment, Door Closure	2		
70	Washer, Sprocket Spacer	6		
<hr/>				
85	Glass, Outer - Door	2	151-491-2M	
86	Lap Strip	2	151-493M	
87	Glass, Inner - Door	2	151-491-1M	
88	Bushing, Spacer	2	151-499C	
89	Door Sweep	2	151-490-8M	
90	Door Handle (with Springs)	1	151-792M	
91	Spring, Door Handle - Top	1	51001-16	
92	Spring, Door Handle - Bottom	1	51001-15	

100	Frame, Light Cover	3	151-583-1	
101	Glass, Light Cover	3	151-583-2	
102	Gasket, Light Cover	3	151-583-4	
103	Light Assembly	3	31602-31	
104	Xenon Lamp	3	31602-28	
<hr/>				
110	Motor, Rack Rotation	1	30200-56-1	
111	Rotator Cam	1	151-523	
112	Bushing	1	50803-002	
113	Drive Gear	1	73000-05c	
114	Bottom Assembly - Rotator	1	151-739	
115	Snap Ring	1	20601-04	
116	Lifting Blade - Rotator	1	151-579	
117	Bushing, Flange	1	70200-11	
118	Driven Gear	1	73000-06a	
119	Bushing, Gear	1	70200-13	
120	Friction Washer	1	70200-14	
121	Top Channel - Rotator	1	150-151a	
122	Roller Switch	1	30301-15	
123	Thrust Bearing	1	70200-12	
124	Rotation Capacitor	1	40704-12	
<hr/>				
135	Motor, Blower	1	30200-66	
136	Clamp, Blower Seal	1	151-271	
137	Seal, Blower	1	151-270	
138	Blower Wheel	1	151-801	
<hr/>				
150	Contactor	1 or 2	30700-17	
151	Transformer	2	31400-32	
152	Terminal Block	1	30500-07	
153	Ground Lug	1	31200-08	
154	Terminal Block	1	30500-01	
155	Breaker (50A)	2	31800-12	Max-E only
<hr/>				
170	Element (208V)	3	151-802-208	208V Max-E only
	Element (240V)	3	151-802-240	240-480V Max-E
<hr/>				
180	Gas Control Module	1	80300-18	Max-G only
<hr/>				
195	Heat Exchanger	1	151-703-3-G	Max-G only
<hr/>				
200	Burner Assembly	1	151-763-1	Max-G only
201	Flame Sensor	1	41100-36-7	Max-G Only
202	Ignitor	1	80302-12	Max-G only
203	In-shot Burner	8	80002-15	Max-G only
204	Orifice	8	80400-49	Natural Gas
205	Draft Inducer	1	30200-86	Max-G only
206	Flexible Gas Connector	1	70302-09	Max-G only
207	Gas Valve	1	80505-15	Max-G only

208	Exhaust Restrictor Plate	1	151-808	Natural Gas
-----	--------------------------	---	---------	-------------

ELECTRICAL SCHEMATICS

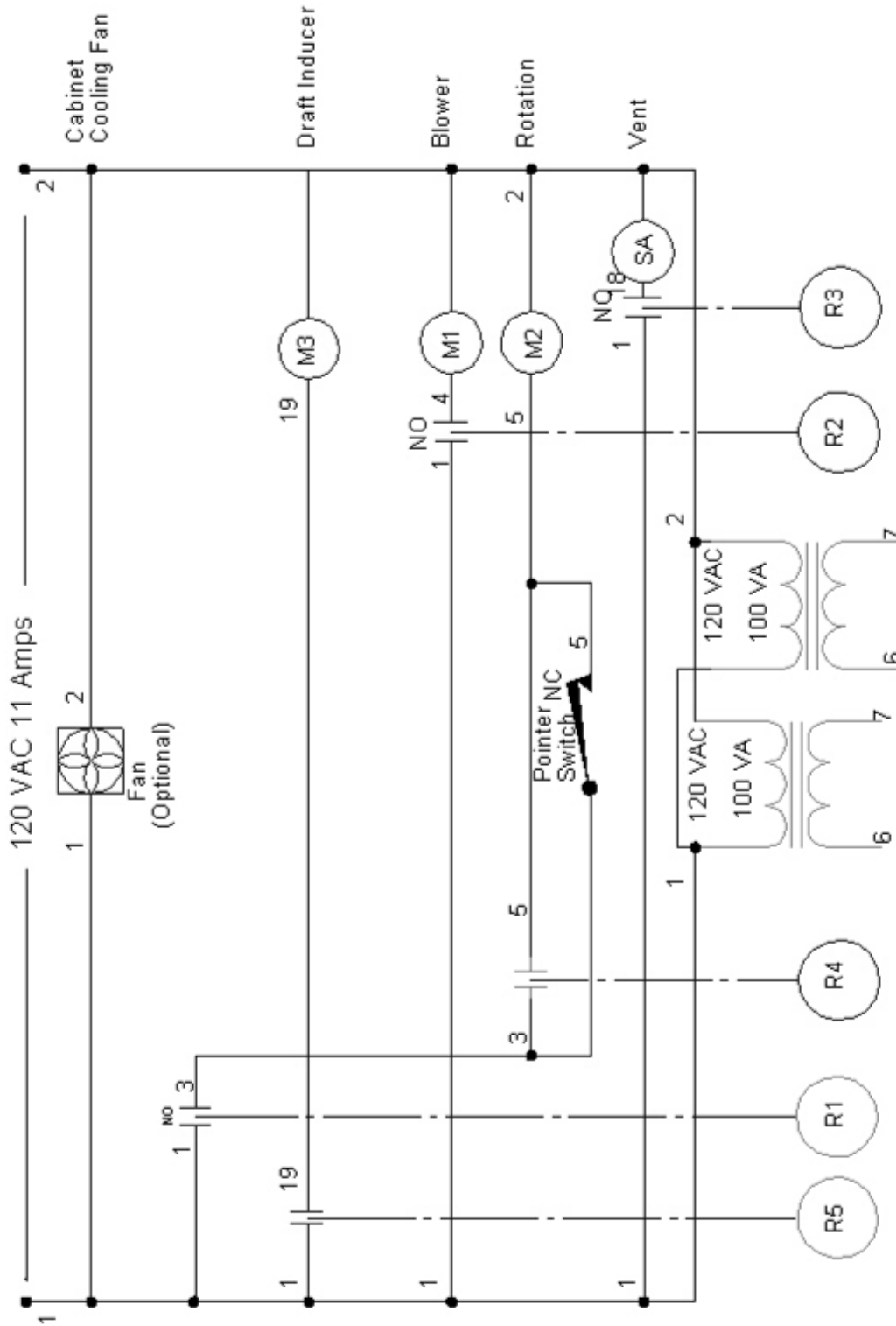

High Voltage Circuit

ELECTRICAL SCHEMATICS (Part 2 of 4)

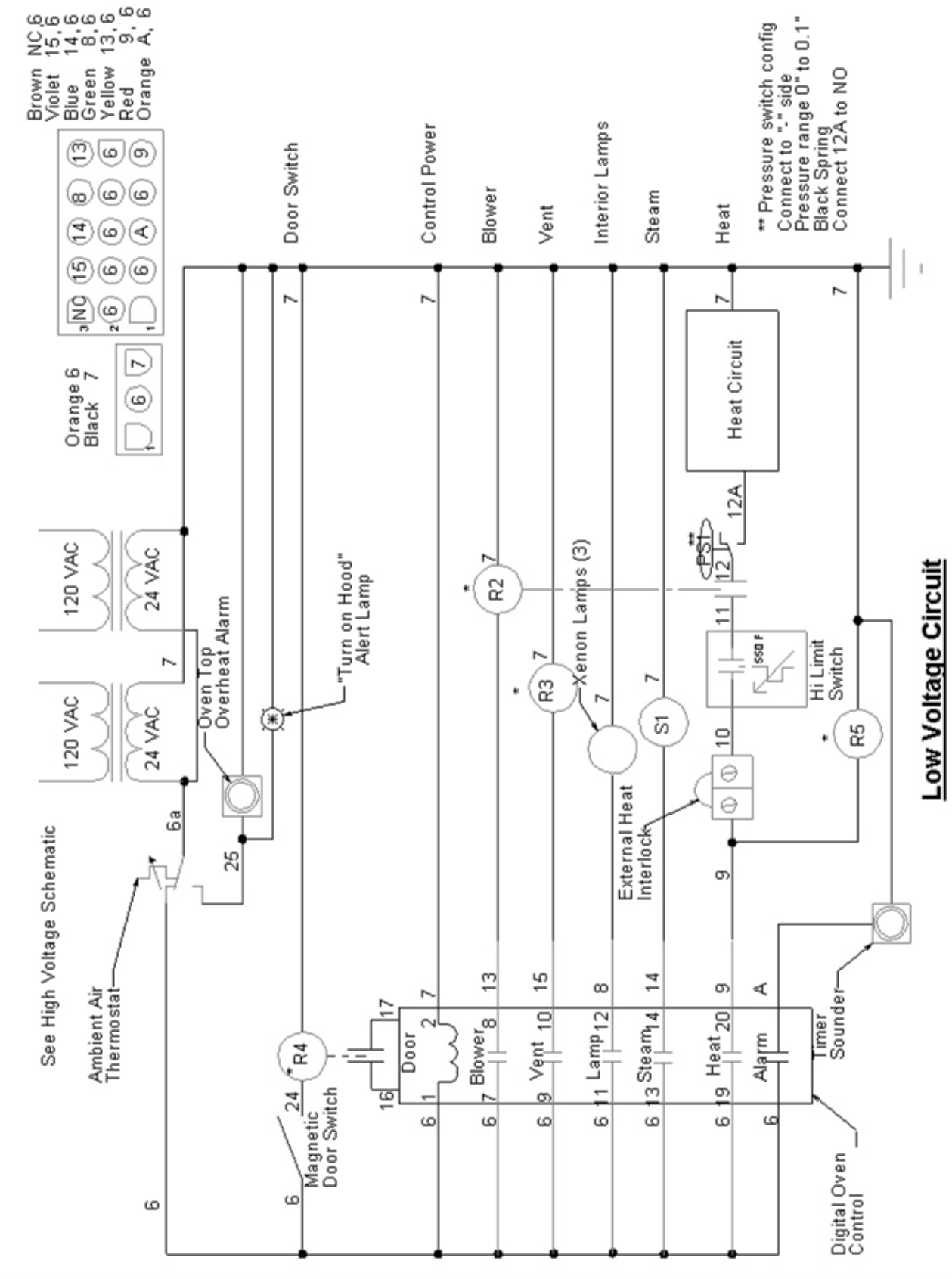

ELECTRICAL SCHEMATICS (Part 3 of 4)

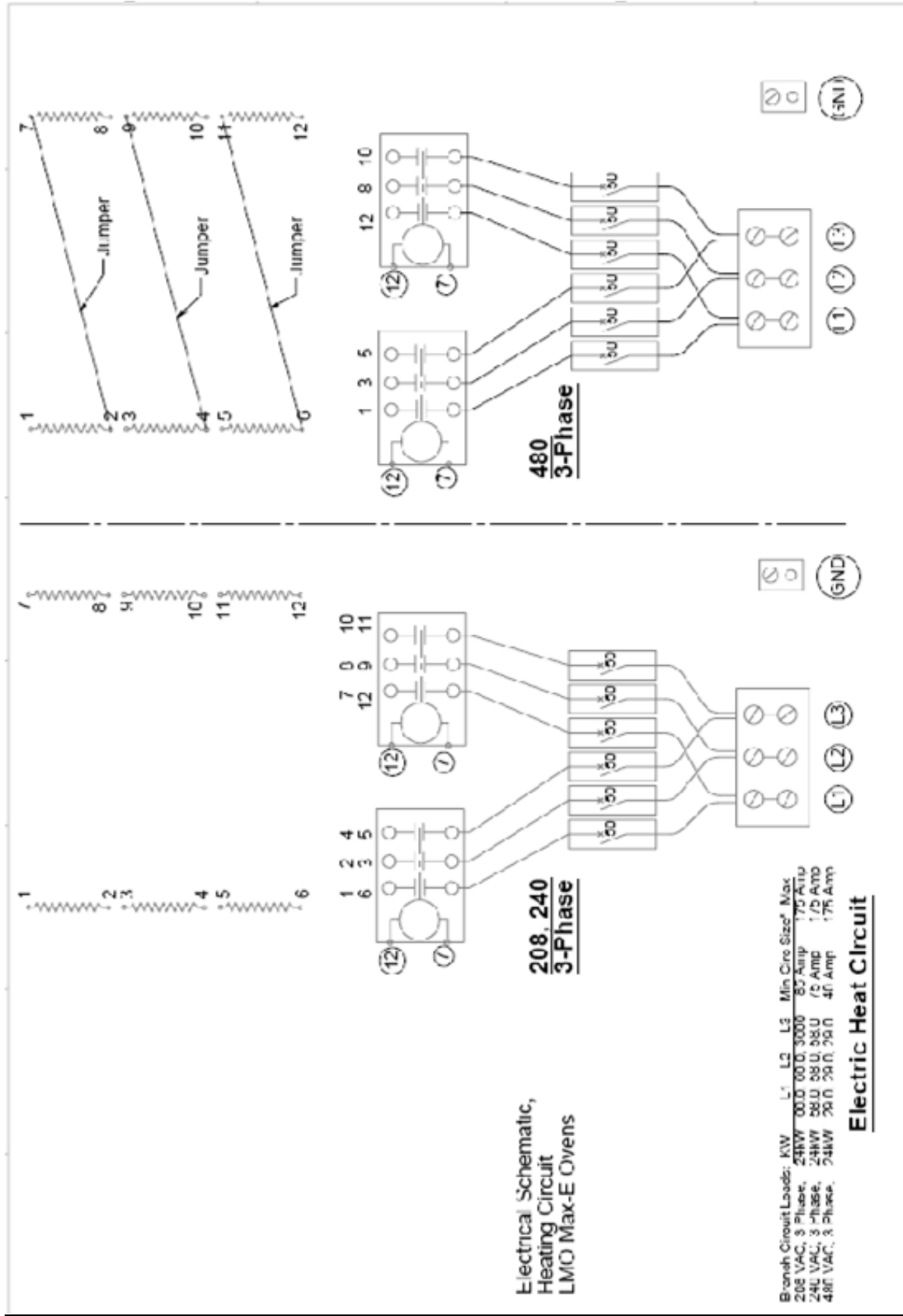

	UNLESS OTHERWISE SPECIFIED DIMENSIONS ARE IN INCHES (MILLIMETERS ARE IN PARENTHESES)	MATERIAL TYPE:	BLANK DIMS:	X	MODEL:
	TOLERANCES ARE: DECIMALS .015 FRACTIONS ±.015 ANGLES ±.015 HOLE DIA ±.015 HOLE DIA ±.015	DRAWN BY: 3H	DATE: 12/4/2015	CHK. DATE:	APP'D. DATE:
DESCRIPTION: Schematic for LMO Ovens					
DWC. NO: 61111-1(H)-7					
					REV:
					SHEET 3 OF 7

ELECTRICAL SCHEMATICS (Part 4 of 4)

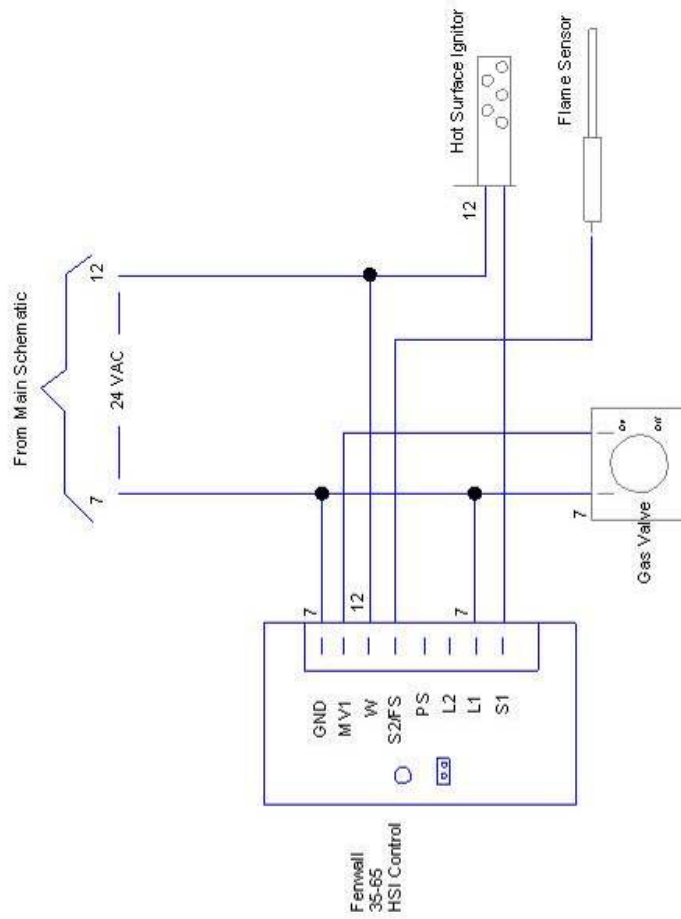

Gas Heat Circuit

LBC Bakery Equipment Everett WA	UNLESS OTHERWISE SPECIFIED DIMENSIONS ARE IN INCHES (PARE)	MATERIAL PART # :	MATERIAL TYPE :	BLANK DIMS. :	X	MODEL:
	TOLERANCES ARE: DECIMALS .0005 FRACTIONS 1/32" HOLE .002 SHAFT .001	DWG. BY: SH	DWG. DATE: 6/15/2015	CHK. BY:	APVD. DATE:	APVD. BY:
DESCRIPTION: Schematic for LMO Ovens						
						SHEET 4 OF 7
						DWG. NO: 61111-180-2
						REV:

LBC LIMITED WARRANTY

LBC Bakery Equipment ("LBC Equipment") has been skillfully manufactured, carefully inspected and packaged to meet rigid standards of excellence. LBC Bakery Equipment Company (LBC) warrants products produced and sold by LBC and its duly authorized agents, against defects in materials and workmanship within the following limitations:

What is Provided:

- Limited replacement parts as specified below, including standard ground shipping from LBC or service parts center when required.
- Limited labor for repair as specified below, including authorized service agent's transportation, portal to portal, up to one hundred (100) miles round trip and two (2) hours travel time.
- LBC, or an authorized service representative, will repair or replace, at LBC's sole discretion, any LBC equipment, including but not limited to the listed exclusions.

Coverage Period:

Extending from the date of shipment from LBC or its duly authorized dealer/distributor for the specified period.

- LRO and LMO Model Rack Ovens, LRP Model Rack Proofers and LRPR Model Retarder Proofers for a period of one (1) year limited parts and labor.
- Replacement parts shall be warranted for a period of ninety (90) days after installation by an authorized LBC service agent.

Conditions:

- Covered equipment must have been properly installed and according to the requirements of the installation manual and all applicable local codes.
- The equipment shall not have been abused, misused or neglected or used for purposes other than intended by LBC.
- Water connected to the appliance shall have been in compliance with the following requirements:
 - Cold water, 30 to 80 PSI
 - pH between 7 and 7.5
 - Conductivity less than 1/500,000 Ω per inch
 - Total dissolved solids less than 100 ppm
 - Hardness from 6.3 to 8.8 grains per gallon
 - Maximum Salinity and Ion content:
 - Chlorides:* < 30 ppm
 - Sulfates:* < 40 ppm
 - Iron:* < 0.1 ppm
 - Copper:* < 0.05 ppm
 - Manganese:* < 0.05 ppm

Conditions (cont):

- It is the responsibility of the purchaser to install and maintain the water supply to the appliance. Failure to provide satisfactory water quality of the appliance in accordance with the operating manual requirements can cause damage to internal components and will VOID the warranty.
- All repair work is to be performed by an LBC authorized service agent.

- Equipment must be at the installation location of the original purchaser/user and shall not have been resold or reclaimed by another party.
- LBC equipment is for commercial use only. If sold as a component of another (OEM) manufacturer's equipment, or if used as a consumer product, such equipment is sold AS IS and without any warranty.
- Conditions of sale of the equipment shall have been met in full.
- The request for repair shall be made within the limited period of the warranty.

Failure to meet the above conditions will void this warranty

Exclusions:

This warranty does not cover the following:

- Routine general maintenance, or periodic adjustment
- Thermostat calibration after the first 30 days of use
- Lamps, Gaskets, Oven Racks and other consumable parts
- Air and gas burner adjustments
- Fuse replacement
- Cleaning and adjusting burners and pilot burners
- Rack oven shutter adjustments
- Repairs, adjustments and corrections in the refrigeration portion of retarder/proofer resulting from the improper installation
- Retightening of screws and fasteners
- Failures caused by erratic or inadequate electrical, water, ventilation or gas service
- Unauthorized repairs
- Premature rusting, corrosion, or mineral build up caused by incoming water
- Attached water treatment systems
- Expedited freight on replacement parts other than standard ground shipments
- Ordinary wear and tear
- Use of the equipment for purposes other than those intended including non-commercial use such as residential or domestic
- Appliances installed outside the contiguous U.S., including Alaska and Hawaii, and Canada
- Incidental costs, charges, loss of business and damages as incurred by the user or others as a result of the use or failure of the equipment
- Work and workmanship of the authorized service agent or others in the repair of the equipment
- Other failures that are beyond the reasonable scope of this warranty
- Damage caused during shipment is to be reported to the carrier, is not covered under this warranty, and is the sole responsibility of the purchaser/user
- Natural disaster

LBC Bakery Equipment, Inc.
6026 31st Ave NE
Tulalip, WA 98271

Toll Free: 888-722-5686
Fax: 425-642-8310
E-mail: service@lcbakery.com
Web: www.lcbakery.com