



SINMAG

Manufacturers of Bakery and Foodservice Equipment



Models LPC-19-E & LPC-31-E

ELECTRIC CONVEYOR OVEN OPERATOR'S MANUAL

RETAIN THIS MANUAL FOR FUTURE REFERENCE.

LBC BAKERY EQUIPMENT, INC.

6026 31ST Ave NE

Marysville, WA 98271, USA

Phone: 888-RACKOVN (888-722-5686)

Email: service@lcbakery.com

Website: www.lcbakery.com

REV B 8/2016

READ FIRST

READ, UNDERSTAND AND FOLLOW THE INSTRUCTIONS AND WARNINGS CONTAINED IN THIS MANUAL. IT IS THE RESPONSIBILITY OF THE OWNER/OPERATORS OF THIS APPLIANCE TO TRAIN, SUPERVISE AND AUTHORIZE ANY PERSON DESIGNATED AS AN OPERATOR. ALL OPERATORS MUST READ AND UNDERSTAND THIS MANUAL.

	WARNING	DO NOT STORE OR USE GASOLINE OR OTHER FLAMMABLE VAPORS OR LIQUIDS IN THE VICINITY OF THIS OR ANY OTHER APPLIANCE.	
	WARNING	IMPROPER INSTALLATION, ADJUSTMENT, SERVICE OR MAINTENANCE CAN CAUSE PROPERTY DAMAGE, INJURY OR DEATH. READ THE INSTALLATION, OPERATING AND MAINTENANCE INSTRUCTIONS THOROUGHLY BEFORE INSTALLING OR SERVICING THIS EQUIPMENT.	
	CAUTION	ALWAYS KEEP THE AREA NEAR THE APPLIANCE FREE FROM COMBUSTIBLE MATERIALS.	

Your LBC Conveyor Oven was manufactured to rigid standards. The appliance has been tested and is listed by Intertek Testing Services (ETL Semko) and meets applicable safety and sanitation standards.

- A) The **responsibility of the manufacturer** is to supply suitable, comprehensive instructions and recommendations for proper operation and maintenance.
- B) All operations, maintenance and repair of this or any appliance must be performed by properly trained and qualified personnel, and all such operations, maintenance and repair must be performed in a diligent manner. It is the **responsibility of the owner/operator** to ensure proper training and diligence of any person coming into contact with either the subject units or the output (product, fumes or otherwise) of the subject units. It is the **responsibility of the owner/operator** to ensure that the subject units are installed and operated in accordance with OSHA Standard 1910.263.
- C) A regular periodic program of cleaning, inspection and maintenance must be established and comprehensive maintenance records maintained. It is the **sole responsibility of the owner/operator** to establish, schedule and enforce the frequency and scope of these programs in keeping with recommended practice and with due consideration given to actual operating conditions.
- D) The appliance must be operated within limits which will not exceed its working limits. It is the **responsibility of the user** to operate this appliance in accordance with the rules and limits described in this manual and the published product specification sheet, and in accordance with the directions and instructions of the owner/operator of the appliance or employer, and in accordance with applicable federal, state and local laws and ordinances.

TABLE OF CONTENTS

CHAPTER	PAGE
Read First	2
Notes	4
Safe Operating Rules	5
Equipment Description	7
Clearance Requirements	8
Configurations	9
Control Operation	10
Changing Belt Direction	11
Cook Time and Set Point Chart	11
Cleaning and Maintenance	12
Warranty	16

NOTES

SAFE OPERATING RULES (Part 1 of 2)

YOU MUST READ AND UNDERSTAND THIS SECTION BEFORE YOU OPERATE THIS APPLIANCE.

Hot Surfaces

- The appliance may be hot. Do not contact hot surfaces without proper protection. Contact with hot surfaces can cause serious burns, loss of skin and hair and the use of limbs.
- Avoid contact with hot surfaces when loading or unloading the oven. Use appliance mitts to load and unload product. Contact with hot product can cause you to react suddenly and result in spilling or dropping the product, which can cause physical harm.

Hot Water, Steam and Spillage Hazards

- This appliance produces steam in the process of cooking, which may be released from the oven interior. Steam is very hot and contact can cause serious burns, loss of skin and hair, loss of the use of limbs and serious injury to eyes and internal organs. Excessive contact with steam can even result in loss of life. When using the sandwich door, keep your face and hands clear of the door opening. Also keep your face and hands clear of the cook chamber entrance and exit openings.
- Steam produced by the appliance can cause the floor to become wet. If this happens, wipe or mop up the water and alert other employees of the hazard. Use caution to avoid slipping when operating this appliance or when in the area of the appliance.
- In the normal operation of the appliance, product intended for cooking may spill onto the floor. If this happens:
 - Mop up and clean up any product on the floor in front of the appliance or in the surrounding work area.
 - Alert other personnel, employees, customers or observers of the hazard.

Sharp Edges and Pinch Hazards

- Use caution to avoid contact with sharp edges. Doors, covers, etc. may have edges that can cut or snag skin and clothes. Use caution when working on, cleaning or servicing the appliance.
- Keep hands and fingers out of the path of the sandwich door when closing to avoid pinching.

Strains, Over-Extension, Over-Exertion and Lifting Hazards

- Use caution when loading or unloading heavy product from the appliance. Cooked product may be heavy and result in sprains, strains or injury to back, arms, hands or legs. Do not lift more than you are safely capable of lifting.

Other Precautions

- Never stand on top of the appliance for any reason.
- Do not store anything on top of the appliance.

Smoke or Fire Hazard

- If you see flames or smoke in or around the appliance:
 - Turn the appliance off and contact your supervisor or an authorized service provider.
 - Call 911 or contact fire safety personnel in accordance with your employer's emergency plan.
- Do not operate the appliance or any other appliance if you hear bangs, pops or other abnormal noises. Turn off the appliance and contact your supervisor or authorized service provider.
- Do not allow any flammable materials to be put into the appliance. The following materials are flammable:
 - Gasoline and petroleum products, including wax and tar.
 - Wood chips, wood and paper.
 - Flour dust and fine corn meal that can become airborne.
 - Charred baked products or any other burned material.
 - Animal and vegetable fats that vaporize or become overheated.

SAFE OPERATING RULES (Part 2 of 2)

YOU MUST READ AND UNDERSTAND THIS SECTION BEFORE YOU OPERATE THIS APPLIANCE.

- Do not operate the appliance if an attached fire suppression system or fire alarm system is dysfunctional or has been discharged. Contact your supervisor or contact the fire safety system servicer.
- If a fire suppression system discharges while you are operating the appliance, turn off the appliance and follow your employer's emergency plan, or exit the building or work area.

Electrical Hazard

- Do not operate the appliance if electrical covers are removed or there are frayed, burned or exposed wires or if any live electrical terminals are exposed. Turn off the appliance and any circuit breaker or disconnect device supplying electrical power to the appliance as described in your employer's emergency plan.
- Do not operate the appliance if any circuit breaker or fuse connected to the appliance becomes tripped and cannot be reset. Contact your supervisor or authorized servicer or electrician to correct the condition before operating the appliance. Alert other employees and service personnel to the hazard.
- Do not operate the appliance if you feel an electrical shock when in contact with the appliance or other devices attached to the appliance. Contact your supervisor or authorized servicer or electrician to correct the condition before operating the appliance. Alert other employees and service personnel to the hazard.
- This appliance is equipped with a three-prong (grounding) plug for protection against shock hazard and should be plugged directly into a properly grounded three-prong receptacle. Do not cut or remove the grounding prong from the plug.

Improper Operation

- Do not operate the appliance if covers, doors or other components are removed.
- Do not operate the appliance if any other person has applied a lock-out on the electrical supply or has tagged the appliance in a way to suggest that the appliance not be used. Contact your supervisor for further instructions or refer to your employer's safety plan.

Health and Safety in Cooked Products

- For the safety and health of those who will consume goods produced through the use of the appliance, use all caution and diligence to prevent the ingestion of any item or material that is unsafe or unfit for human consumption.
- Do not use the appliance if you see any material floating in the air in the appliance or if you see any foreign matter in the finished food product.
- Do not use the appliance if you smell unfamiliar smells or if you smell any odor that you know to be unhealthy.
- Do not under-cook any product that can carry bacteria such as but not limited to e-coli, salmonella or any other pathogen.
- Do not cook, roast or handle any meat or meat product that contains any known diseases or pathogens.
- In all cases, follow all food-safe practices as mandated by law and your employer.

EQUIPMENT DESCRIPTION

Exterior Dimensions

See Configurations Section.

Construction

- The exterior top, front, rear and sides are constructed of stainless steel, as is the sandwich door and oven interior (including all interior ducting, conveyor belt and entrance/exit shelves).
- The exterior underside is constructed of corrosion-resistant aluminized steel.
- The sandwich door window is constructed of thick, tempered safety glass.

Performance

- Fast-acting Firebar® elements utilized for rapid run-up and recovery.
- Rear-mounted fan thoroughly circulates convection air for rapid cooking and even browning of the food product.
- The cook chamber is insulated with high-temp insulation for reduced heat loss and increased energy efficiency.

Controls

- Simple, intuitive and easy-to-understand layout.
- Large displays for time and temperature.
- Belt Time Range: 03m:00s – 30m:00s.
- Set Point Range: 145-570°F.
- Temperature scale can be easily set to either °F or °C.
- On shutdown, the last settings used are retained in memory and reappear on the subsequent startup.

Features

- Cool-Down Feature. This automatic feature allows the oven to cool slowly to extend the life of the interior electrical components. On shutdown, if the oven cook chamber temperature exceeds 200°F [93°C], the heater fans continue to run for a period after the heaters have turned off. Once the oven cook chamber temperature has dropped to 200°F [93°C], the fans will automatically stop and the control will turn off. While in cool-down Mode, the word “Cool” will appear in the Conveyor Speed display.
- Change Belt Direction. The direction of the belt can be changed to run from left to right or right to left. A two-position belt-direction switch with identifying label is located at the backside of the cook chamber. Set the switch to your desired direction.

CLEARANCE REQUIREMENTS

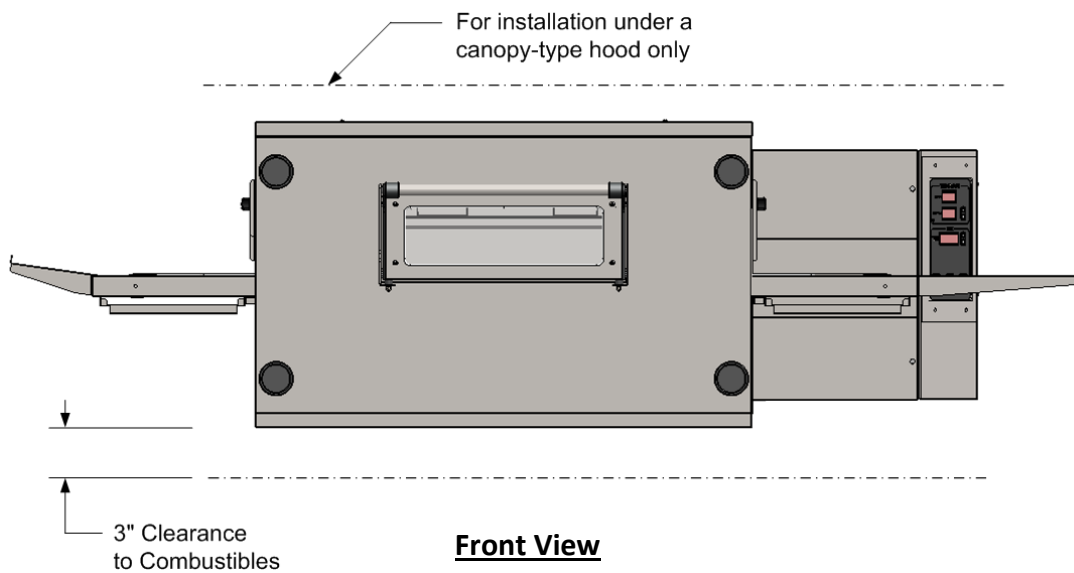
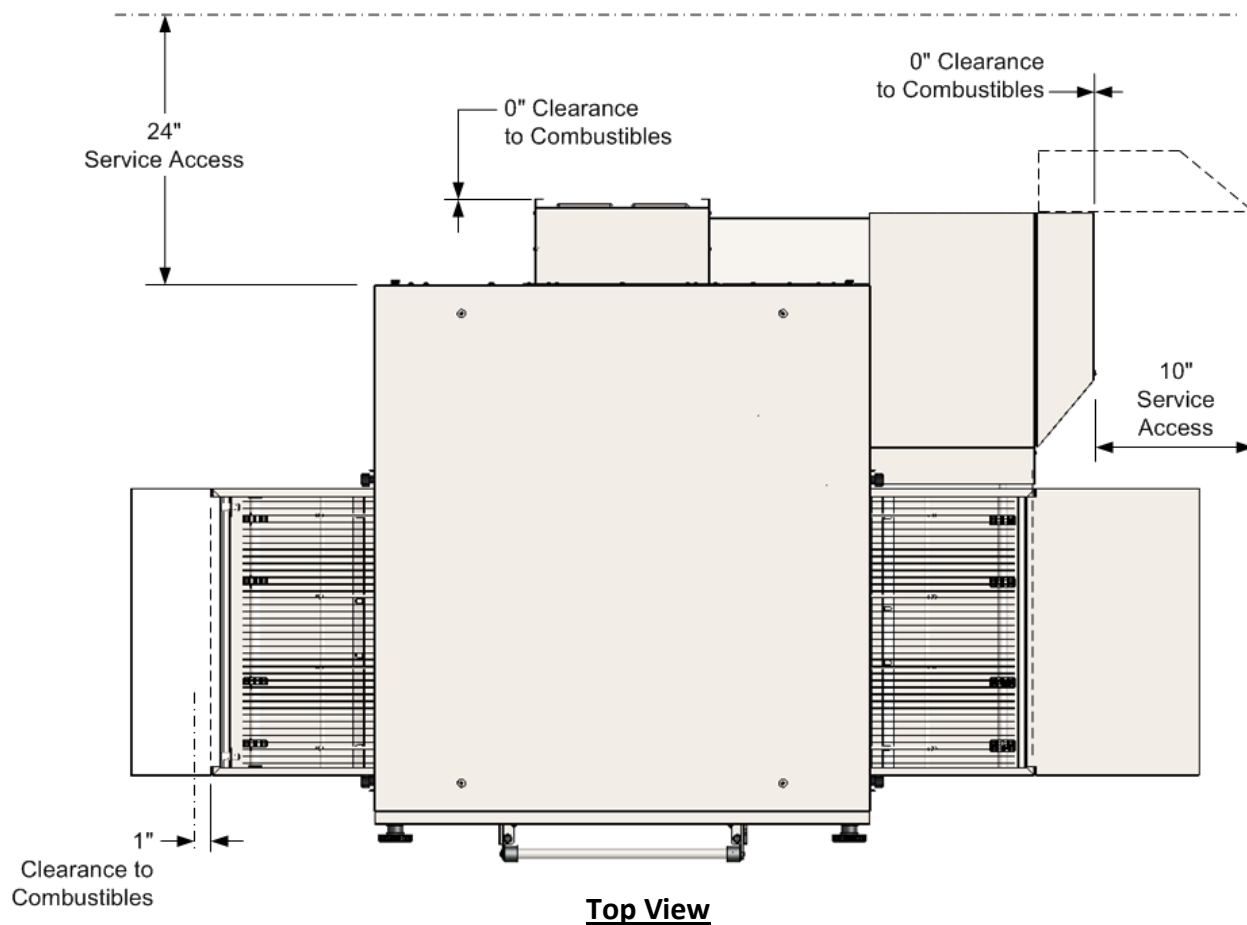

CONFIGURATIONS

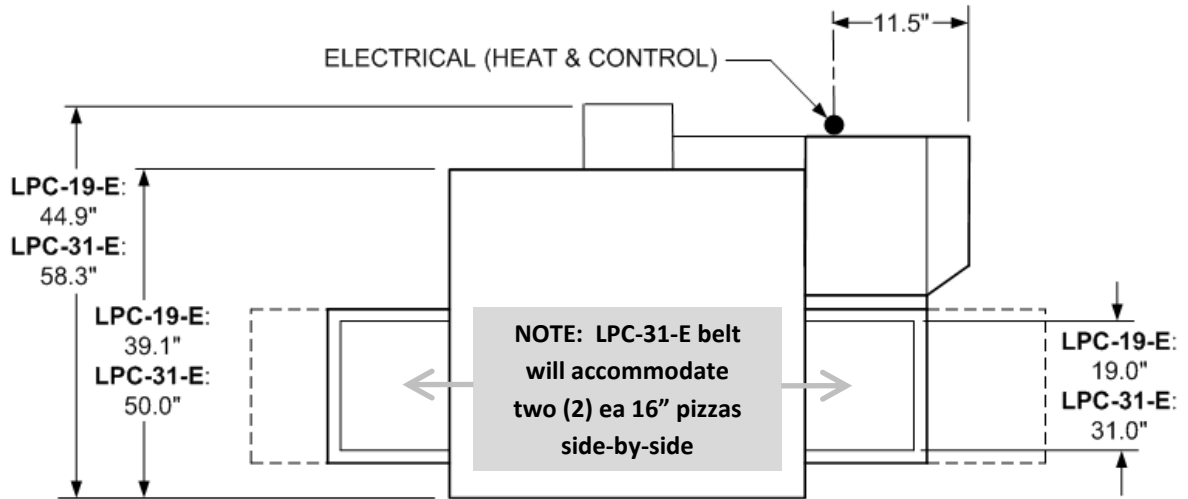

Top View

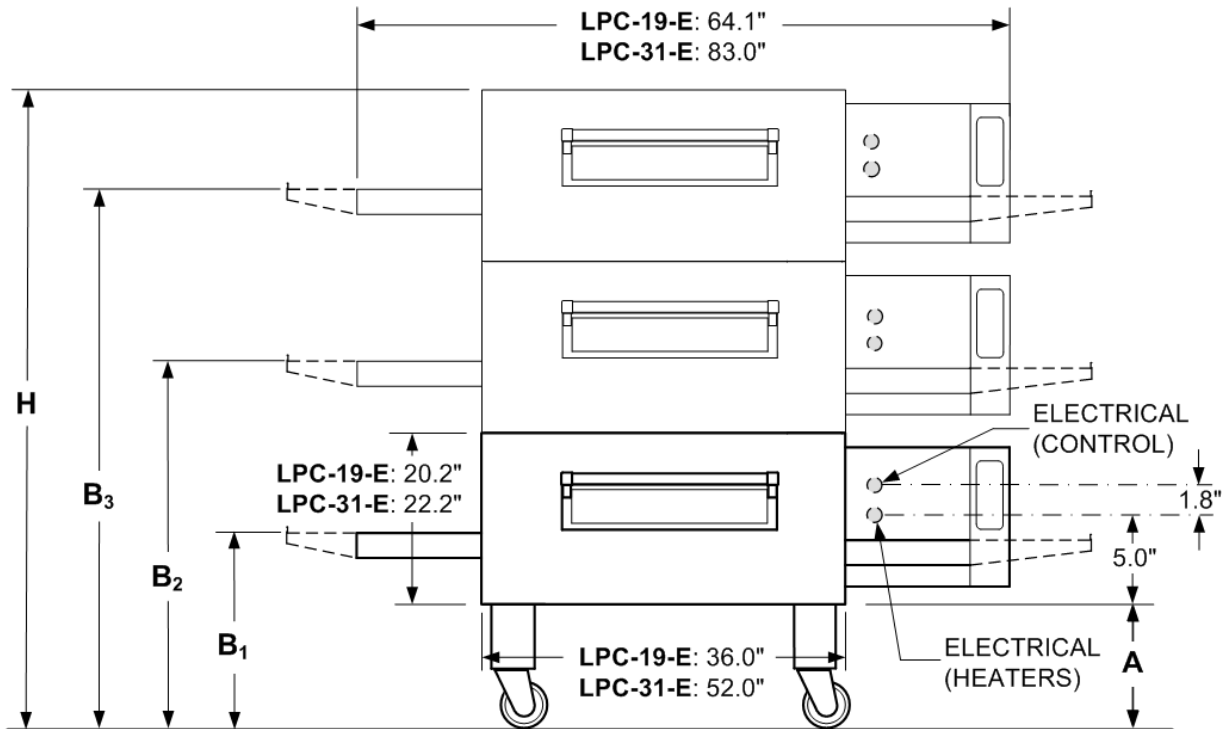

Front View

Appliance Dimensions:

Dims	LPC-19-E-1 (1 Deck)	LPC-19-E-2 (2 Decks)	LPC-19-E-3 (3 Decks)	LPC-31-E-1 (1 Deck)	LPC-31-E-2 (2 Decks)	LPC-31-E-3 (3 Decks)
A	21.7"	16.9"	5.6"	21.7"	16.9"	5.6"
B ₁	32.6"	27.8"	16.6"	34.6"	29.8"	18.6"
B ₂	N/A	48.0"	36.8"	N/A	52.0"	40.8"
B ₃	N/A	N/A	57.0"	N/A	N/A	63.0"
H	43.8"	59.2"	68.2"	47.8"	65.2"	76.1"

CONTROL OPERATION

NOTICE

During the first few hours of operation, you may notice a small amount of smoke and/or a faint odor coming from the appliance. This is normal in new equipment and will disappear after a few hours of use.

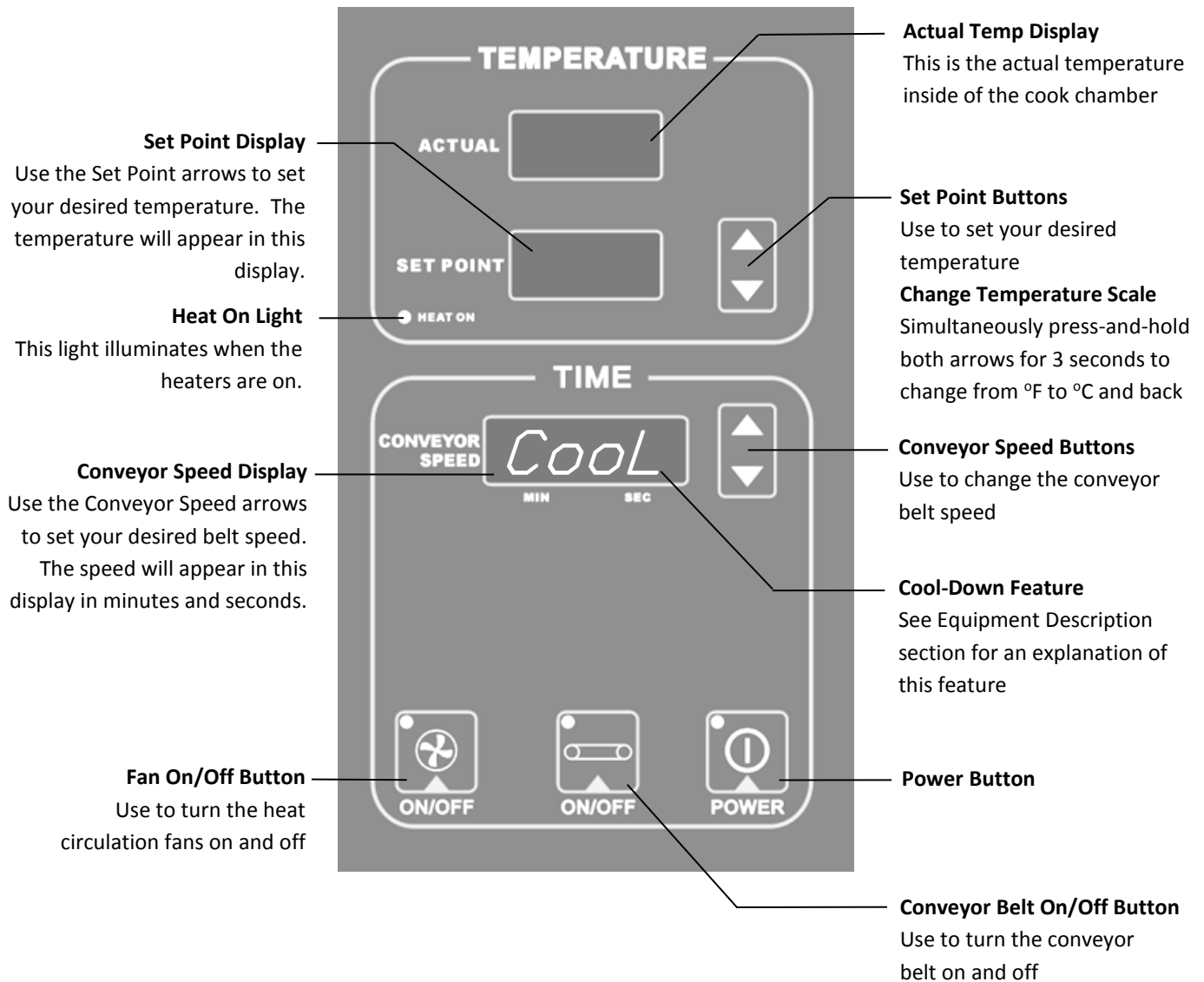

CHANGING BELT DIRECTION











To change the direction of the conveyor belt, locate the two-position switch with identifying label at the backside of the cook chamber. Set the switch to your desired direction.

COOK TIME and SET POINT CHART

NOTE: Settings shown are for reference only. Your settings may vary.

Product	Cook Time	Set Point
Bagel Bites	5:00 min	425°F [218°C]
Bagel, Open Face	1:00 min	550°F [288°C]
Bisquits	6:45 min	325°F [163°C]
Bread, Garlic (rethermalized)	2:30 min	475°F [246°C]
Bread Sticks (frozen)	6:00 min	450°F [232°C]
Bread Sticks (rethermalized)	4:30 min	475°F [246°C]
Cheese Sticks (frozen)	6:00 min	450°F [232°C]
Cheese Sticks (rethermalized)	4:30 min	475°F [246°C]
Chicken Nuggets (frozen)	6:00 min	450°F [232°C]
Cookies	9:00 min	375°F [191°C]
Jalapiño Poppers	6:45 min	400°F [204°C]
Pizza (fresh)	6:30 min	475°F [246°C]
Pizza (frozen, slacked in refrigerator 12 hrs)	6:30 min	425°F [218°C]
Pizza (par-baked crust)	6:30 min	525°F [274°C]
Pizza (rethermalized)	3:30 min	500°F [260°C]
Pizza Slice (rethermalized)	2:15 min	500°F [260°C]
Sandwich, Open Face	1:00 min	550°F [288°C]

CLEANING and MAINTENANCE (Part 1 of 4)

	WARNING	DISABLE ELECTRICAL POWER AT SERVICE BREAKER BEFORE CLEANING OVEN.	
	WARNING	KEEP WATER AND SOLUTIONS OUT OF CONTROLS. NEVER SPRAY OR HOSE CONTROL CONSOLE.	
	CAUTION	ALWAYS KEEP THE AREA NEAR THE APPLIANCE FREE FROM COMBUSTIBLE MATERIALS.	
	CAUTION	KEEP THE FLOOR IN FRONT OF THE APPLIANCE CLEAN AND DRY. IF SPILLS OCCUR, CLEAN THEM IMMEDIATELY TO AVOID THE DANGER OF SLIPS OR FALLS.	
	CAUTION	MOST CLEANERS ARE HARMFUL TO THE SKIN, EYES, MUCOUS MEMBRANES AND CLOTHING. PRECAUTIONS SHOULD BE TAKEN WHEN USING THEM. WEAR RUBBER GLOVES, GOGGLES OR FACE SHIELD AND PROTECTIVE CLOTHING. CAREFULLY READ THE WARNING AND FOLLOW THE DIRECTIONS ON THE LABEL OF THE CLEANER TO BE USED.	
	NOTICE	Never use chlorine-based cleansers on this appliance. Chlorine corrodes stainless steel.	
	NOTICE	To maintain optimum safety and performance, it is recommended that a program of regular maintenance be implemented. It is the sole responsibility of the user to establish, schedule and enforce such a program. Although the actual service schedule will vary depending on the environment in which the equipment is operating, it is recommended that the above be done by an LBC-authorized service representative every six months.	

Daily Cleaning

Use a mild detergent or stainless steel cleaner for the following cleaning steps:

- Empty and clean crumb trays
- Clean exterior surfaces
- Clean sandwich door (including the inner glass surface)
- Clean conveyor belt surface

CLEANING and MAINTENANCE (Part 2 of 4)

Weekly Cleaning

Use a mild detergent or stainless steel cleaner to clean the oven interior per the following steps:

- Remove the front retaining knobs and remove the front panel.

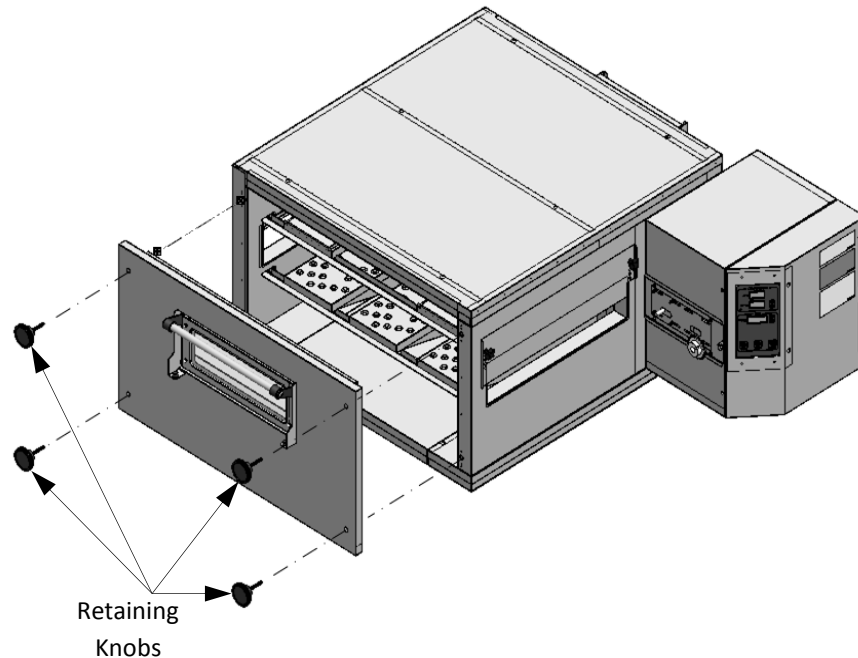

- Remove and clean the conveyor belt assembly. To do this, locate chain cover at side of the control compartment (Illustration 1) and remove cover retention screw with a phillips screwdriver. Slide cover in direction of arrow shown in photo. Lift frame at each corner (Illustration 2) and slide frame into oven approximately one inch. Chain should be loose on sprocket (Illustration 3). Disengage chain from conveyor belt sprocket and remove conveyor from oven interior by sliding it from control end of the cook chamber.



CAUTION

THE CONVEYOR BELT ASSEMBLY IS HEAVY. FOR SAFE HANDLING, OBTAIN HELP AS NEEDED OR EMPLOY APPROPRIATE MATERIAL-HANDLING EQUIPMENT TO REMOVE THE ASSEMBLY FROM THE APPLIANCE AND TO MOVE IT TO A SUITABLE LOCATION FOR CLEANING.



Illustration 1



Illustration 2



Illustration 3

CLEANING and MAINTENANCE (Part 3 of 4)

- Next, gently lift and slide the horizontal ducts toward the front of the cook chamber. No tools are required. (NOTE: Both top ducts match one another and can be reinstalled in any order; there is no need to number them. All bottom ducts also match one another and can be reinstalled in any order. To further help avoid mistakes during reinstallation, the oven has been designed so the top ducts fit only in the top position and the bottom ducts fit only in the bottom position.)

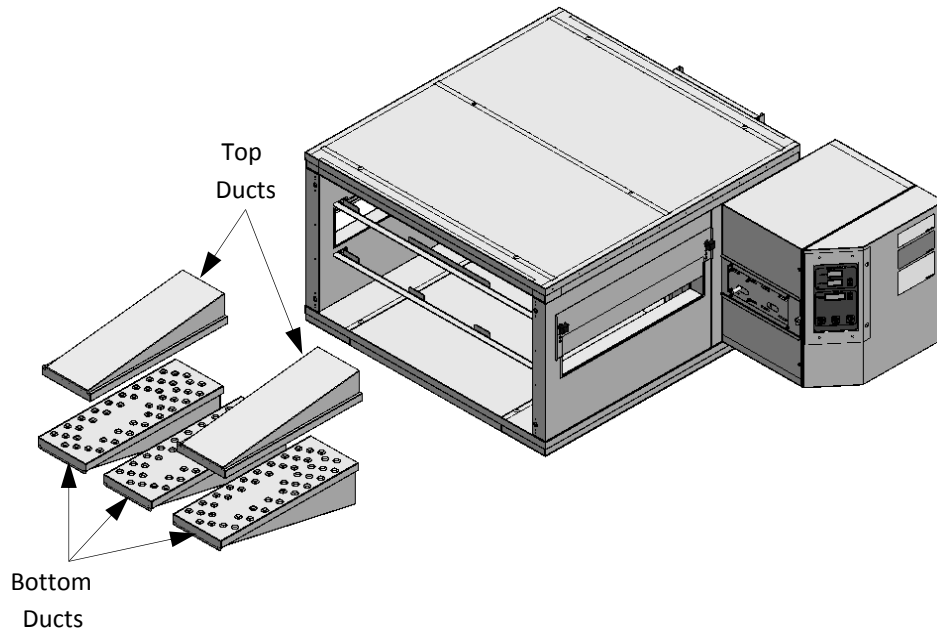



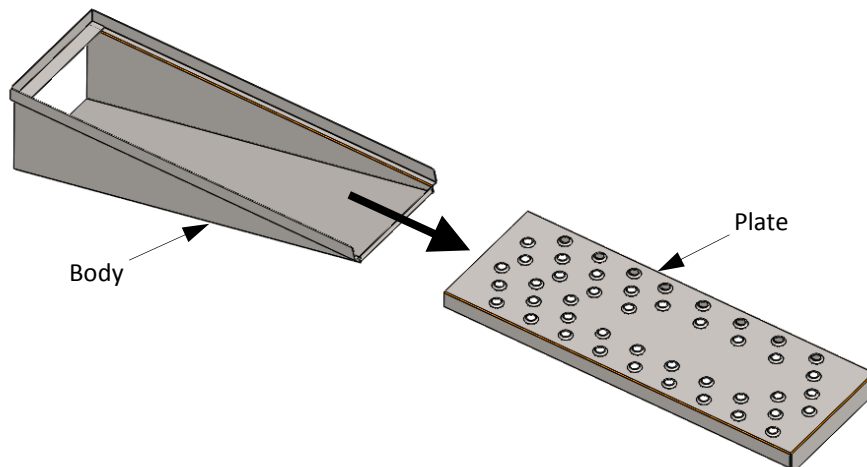

- Disassemble horizontal ducts for cleaning. No tools are required. Slide plate from duct body in direction indicated by arrow. When cleaning, it is important to remove food particles and residue from all perforated holes of all duct parts.



- With conveyor belt assembly removed, clean oven cook chamber.
- Follow the steps outlined above in reverse order to reassemble the oven.

CLEANING and MAINTENANCE (Part 4 of 4)

	WARNING	BOTH HIGH AND LOW VOLTAGES ARE PRESENT INSIDE OF THIS APPLIANCE WHEN THE UNIT IS PLUGGED/WIRED INTO A LIVE RECEPTACLE. BEFORE REPLACING ANY PARTS, DISCONNECT THE UNIT FROM THE ELECTRIC POWER SUPPLY.	
	CAUTION	USE OF ANY REPLACEMENT PARTS OTHER THAN THOSE SUPPLIED BY LBC OR THEIR AUTHORIZED DISTRIBUTORS CAN CAUSE BODILY INJURY TO THE OPERATOR AND/OR DAMAGE TO THE APPLIANCE AND WILL VOID ALL WARRANTIES.	
	NOTICE	Service on this or any other LBC appliance must be performed by qualified personnel. For an approved service representative in your area, visit our website at www.lcbakery.com or call our factory toll free at 1-888-722-5686.	

Periodic Preventive Maintenance

A regular preventive maintenance schedule must be established. The time interval for preventive maintenance will depend on the environment in which the oven is operating – including total hours of use, type of food product being cooked, etc. Maintenance is necessary to keep the fans and motor free from dust and debris, thus extending the life of your appliance. Refer to the Service / Preventive Maintenance section of the Installation, Service & Parts Manual. Periodic preventive maintenance should be done by an LBC-authorized service technician. If you need help locating an approved servicer in your area, contact LBC Bakery Equipment.



LIMITED WARRANTY

LBC Bakery Equipment ("LBC Equipment") has been skillfully manufactured, carefully inspected and packaged to meet rigid standards of excellence. LBC Bakery Equipment, Inc. (LBC) warrants products produced and sold by LBC and its duly authorized agents against defects in materials and workmanship within the following limitations:

What is Provided:

- Limited replacement parts as specified below, including standard ground shipping from LBC or service parts center when required.
- Limited labor for repair as specified below, including authorized service agent's transportation, portal to portal, up to one hundred (100) miles round trip and two (2) hours travel time.
- LBC, or an authorized service representative, will repair or replace, at LBC's sole discretion, any LBC equipment, including but not limited to the listed exclusions.

Coverage Period:

Extending from the date of shipment from LBC or its duly authorized dealer/distributor for the specified period:

- LRO and LMO Model Rack Ovens, LRP Model Rack Proofers, LRPR Model Retarder Proofers, LCR Model Rotisseries and LHC Model Holding Cabinets for a period of one (1) year limited parts and labor.
- Replacement parts shall be warranted for a period of ninety (90) days after installation by an authorized LBC service agent.

Conditions:

- Covered equipment must have been properly installed according to the requirements of the installation manual and all applicable local codes.
- The equipment shall not have been abused, misused or neglected or used for purposes other than intended by LBC.
- Water connected to the appliance shall have been in compliance with the following requirements:
 - Cold Water: 30 - 80 PSI
 - pH: 7 - 7.5
 - Conductivity: < 1/500,000 Ω per inch
 - Total Dissolved Solids: < 100 ppm
 - Hardness: 6.3 - 8.8 grains per gallon
 - Maximum Salinity and Ion content:
 - Chlorides: < 30 ppm
 - Sulfates: < 40 ppm
 - Iron: < 0.1 ppm
 - Copper: < 0.05 ppm
 - Manganese: < 0.05 ppm
- It is the responsibility of the purchaser to install and maintain the water supply to the appliance. Failure to provide satisfactory water quality in accordance with the operating manual requirements can cause damage to internal components and will VOID the warranty.
- All repair work is to be performed by an LBC authorized service agent.
- Equipment must be at the installation location of the original purchaser/user and shall not have been resold or reclaimed by another party.

Conditions (Continued):

- LBC equipment is for commercial use only. If sold as a component of another (OEM) manufacturer's equipment, or if used as a consumer product, such equipment is sold AS IS and without any warranty.
- Conditions of sale of the equipment shall have been met in full.
- The request for repair shall be made within the limited period of the warranty.
Failure to meet the above conditions will void this warranty.

Exclusions:

This warranty does not cover the following:

- Routine general maintenance, or periodic adjustment.
- Thermostat calibration after the first 30 days of use.
- Glass, Lamps, Gaskets, Oven Racks and other consumable parts.
- Air and gas burner adjustments.
- Fuse replacement.
- Cleaning and adjusting burners and pilot burners.
- Rack oven shutter adjustments.
- Repairs adjustments and corrections in the refrigeration portion of retarder/proofers resulting from the improper installation.
- Retightening of screws and fasteners.
- Failures caused by erratic or inadequate electrical, water, ventilation or gas service.
- Unauthorized repairs.
- Premature rusting, corrosion, or mineral build up caused by incoming water.
- Attached water treatment systems.
- Expedited freight on replacement parts other than standard ground shipments.
- Ordinary wear and tear.
- Use of the equipment for purposes other than those intended including non-commercial use such as residential or domestic.
- Appliances installed outside the contiguous U.S., including Alaska and Hawaii, and Canada.
- Incidental costs, charges, loss of business and damages as incurred by the user or others as a result of the use or failure of the equipment.
- Work and workmanship of the authorized service agent or others in the repair of the equipment.
- Other failures that are beyond the reasonable scope of this warranty.
- Damage caused during shipment is to be reported to the carrier, is not covered under this warranty, and is the sole responsibility of the purchaser/user.
- Natural disaster.

This warranty is exclusive and in lieu of all other warranties, expressed or implied, including expressed or implied warranties of merchantability or fitness for a particular purpose, each of which is hereby expressly disclaimed. The remedies described herein are exclusive and in no event shall LBC be liable for special, consequential or incidental damages for the breach or delay in the performance of this warranty