



Models / Modelos/ Modèles:

LRO-1G5, LRO-2G5, LRO-1E5, LRO-2E5

Installation, Service and Parts Manual

Installation, Service et Pièces Manuel / Instalación, Servicio y Manual de Piezas

Keep This Manual with the Oven

Conservez ce Manuel avec le Four / Mantener este Manual con el Horno

LBC Bakery Equipment, Inc.

6026 31st Ave NE, Marysville, WA 98271, USA

Toll Free: 888-722-5686

Email: sales@lcbakery.com

Rev: 5-2022

Contents

Notes	3
Notices (English)	4
Notices (Français)	5
Notices (Española)	6
Specifications (Gas Ovens)/ Specifications / Especificaciones	7
Specifications (Electric Ovens)/ Spécifications / Especificaciones	8
Drawings	9
Conditions of Installation / <i>Les conditions d'Installation</i> / <i>Condiciones la Instalación</i>	11
Must Read! (English).....	13
Doit lire! (Français)	15
Debe leer! (Español)	17
Assembly (English).....	19
Assemblée (Français).....	19
Asamblea (Español)	19
Electrical Connections (Gas)	20
Electrical Connections (Electric 208-240 Volt)	21
Electrical Connections (480 Volt Electric).....	22
Gas Connection (English)	23
Connexion au gaz (Français).....	24
Conexión de gas (Español).....	25
Start-Up Instructions	26
Air Shutter Settings LRO-1	30
Air Shutter Settings LRO-2	31
Illustrated Parts List / Liste illustrée des pièces / Ilustrado Lista de Piezas.....	32
Schematics.....	47
Limited Warranty.....	54

Notes

THIS MANUAL MUST BE RETAINED FOR FUTURE REFERENCE. READ, UNDERSTAND AND FOLLOW THE INSTRUCTIONS AND WARNINGS CONTAINED IN THIS MANUAL.

CE MANUEL DOIT ÊTRE RETENU POUR RÉFÉRENCE FUTURE. LIRE, COMPRENDRE ET SUIVRE LES INSTRUCTIONS ET LES AVERTISSEMENTS CONTENUS DANS CE MANUEL.

ESTE MANUAL DEBE SER RETENIDO PARA FUTURAS REFERENCIAS. LEA, ENTIENDA Y SIGA LAS INSTRUCCIONES Y ADVERTENCIAS CONTENIDAS EN ESTE MANUAL.

Notices (English)

FOR YOUR SAFETY

DO NOT STORE OR USE GASOLINE OR OTHER FLAMABLE LIQUIDS IN THE VICINITY OF THIS OR ANY OTHER APPLIANCE.

POST IN A PROMINENT LOCATION.

IF YOU SMELL GAS, TURN OFF THE GAS AND CALL YOUR GAS SUPPLIER AND YOUR AUTHORIZED SERVICE AGENT. EVACUATE ALL PERSONNEL FROM THE AREA.

WARNING

IMPROPER INSTALLATION, ADJUSTMENT, ALTERATION, SERVICE OR MAINTENANCE CAN CAUSE DAMAGE, INJURY OR DEATH. READ THE INSTALLATION MANUAL THOROUGHLY BEFORE INSTALLING OR SERVICING THIS EQUIPMENT.

IT IS THE **RESPONSIBILITY OF THE MANUFACTURER** TO PROVIDE SUITABLE, COMPREHENSIVE INSTRUCTIONS AND RECOMMENDATIONS FOR PROPER INSTALLATION, OPERATION AND MAINTENANCE.

IT IS THE **RESPONSIBILITY OF THE OWNER/OPERATOR** TO INSURE THE PROPER TRAINING AND DILIGENCE OF ANY PERSON COMING INTO CONTACT WITH THE OVENS OR THEIR OUTPUT. IT IS THE RESPONSIBILITY OF THE OWNER/OPERATOR TO ENSURE THAT THE OVEN IS INSTALLED AND OPERATED IN ACCORDANCE WITH OSHA STANDARD 1910.263.

A REGULAR PERIODIC PROGRAM OF CLEANING, INSPECTION AND MAINTENANCE MUST BE ESTABLISHED AND COMPREHENSIVE MAINTENANCE RECORDS MAINTAINED. IT IS THE **SOLE RESPONSIBILITY OF THE OWNER/OPERATOR** TO ESTABLISH, SCHEDULE AND ENFORCE THE FREQUENCY AND SCOPE OF THESE PROGRAMS IN KEEPING WITH RECOMMENDED PRACTICE AND WITH DUE CONSIDERATION GIVEN TO ACTUAL OPERATING CONDITIONS.

THIS OVEN MUST BE OPERATED WITHIN LIMITS, WHICH WILL NOT EXCEED ITS WORKING LIMITS. IT IS THE **RESPONSIBILITY OF THE USER** TO OPERATE THIS OVEN IN ACCORDANCE WITH THE RULES AND LIMITS DESCRIBED IN THIS MANUAL AND THE PUBLISHED PRODUCT SPECIFICATION SHEET, AND IN ACCORDANCE WITH THE DIRECTIONS AND INSTRUCTIONS OF THE OWNER/OPERATOR OF THE OVEN OR EMPLOYER, AND IN ACCORDANCE WITH APPLICABLE FEDERAL, STATE AND LOCAL LAWS AND ORDINANCES.

Notices (Français)

POUR VOTRE SÉCURITÉ

NE PAS ENTREPOSER OU UTILISER DE L'ESSENCE OU D'AUTRES LIQUIDES INFLAMMABLES À PROXIMITÉ DE CET APPAREIL OU DE TOUT AUTRE APPAREIL.

POSTE DANS UN ENDROIT PROBABLE.

SI VOUS SENTEZ DU GAZ, ARRÊTEZ LE GAZ ET APPELER VOTRE FOURNISSEUR DE GAZ ET VOTRE AGENT DE SERVICE AUTORISÉ. ÉVACUEZ TOUT LE PERSONNEL DE LA ZONE

ATTENTION

UNE INSTALLATION, UN AJUSTEMENT, UNE MODIFICATION, UN ENTRETIEN OU UNE MAINTENANCE INCORRECTS PEUVENT ENTRAÎNER DES DOMMAGES, DES BLESSURES OU LA MORT. LIRE ATTENTIVEMENT LE MANUEL D'INSTALLATION AVANT D'INSTALLER OU D'ENTREtenir CET APPAREIL.

IL EST DE **LA RESPONSABILITÉ DU FABRICANT** DE FOURNIR DES INSTRUCTIONS ET DES RECOMMANDATIONS ADÉQUATES ET COMPLÈTES POUR UNE INSTALLATION, UN FONCTIONNEMENT ET UN ENTRETIEN APPROPRIÉS.

IL EST DE LA **RESPONSABILITÉ DU PROPRIÉTAIRE / OPÉRATEUR** D'ASSURER L'APPRENTISSAGE ET LA DILIGENCE APPROPRIÉS DE TOUTE PERSONNE ENTRANT EN CONTACT AVEC LES FOURS OU LEUR SORTIE. IL EST DE LA RESPONSABILITÉ DU PROPRIÉTAIRE / OPERATEUR DE S'ASSURER QUE LE FOUR EST INSTALLÉ ET FONCTIONNÉ CONFORMÉMENT À LA NORME OSHA 1910.263.

UN PROGRAMME PÉRIODIQUE RÉGULIER DE NETTOYAGE, D'INSPECTION ET D'ENTRETIEN DOIT ÊTRE ÉTABLI ET DES DOSSIERS D'ENTRETIEN COMPLETS SONT MAINTENUS. IL EST DE LA SEULE **RESPONSABILITÉ DU PROPRIÉTAIRE / OPÉRATEUR** D'ÉTABLIR, DE CALCULER ET D'APPLIQUER LA FRÉQUENCE ET L'ÉTENDUE DE CES PROGRAMMES EN FONCTION DES PRATIQUES RECOMMANDÉES ET EN TENANT COMPTE DES CONDITIONS D'EXPLOITATION RÉELLES.

CE FOUR DOIT FONCTIONNER DANS LES LIMITES QUI NE DÉPASSERONT PAS SES LIMITES DE TRAVAIL. IL INCOMBE **À L'UTILISATEUR DE FAIRE FONCTIONNER** CE FOUR CONFORMÉMENT AUX RÈGLES ET LIMITES DÉCRITES DANS CE MANUEL ET DANS LA FICHE DE SPÉCIFICATION DU PRODUIT PUBLIÉ, ET CONFORMÉMENT AUX DIRECTIVES ET INSTRUCTIONS DU PROPRIÉTAIRE / EXPLOITANT DU FOUR OU DE L'EMPLOYEUR, ET CONFORMITÉ AUX LOIS ET ORDONNANCES FÉDÉRALES, LOCALES ET LOCALES APPLICABLES.

Notices (Española)

POR TU SEGURIDAD

NO ALMACENE NI UTILICE GASOLINA U OTROS LÍQUIDOS INFLAMABLES EN EL LUGAR DE ESTE O CUALQUIER OTRO APARATO.

PUBLICAR EN UNA UBICACIÓN PROMINENTE.

SI HUELE GAS, APAGUE EL GAS Y LLAME A SU PROVEEDOR DE GAS YA SU AGENTE DE SERVICIO AUTORIZADO. EVACUE A TODO EL PERSONAL DE LA ZONA.

ADVERTENCIA

LA INSTALACIÓN, EL AJUSTE, LA ALTERACIÓN, EL SERVICIO O EL MANTENIMIENTO INADECUADOS PUEDEN CAUSAR DAÑOS, LESIONES O LA MUERTE. LEA EL MANUAL DE INSTALACIÓN ANTES DE INSTALAR O REALIZAR EL MANTENIMIENTO DE ESTE EQUIPO.

ES LA **RESPONSABILIDAD DEL FABRICANTE** PROPORCIONAR INSTRUCCIONES Y RECOMENDACIONES ADECUADAS Y COMPENSIBLES PARA UNA INSTALACIÓN, FUNCIONAMIENTO Y MANTENIMIENTO ADECUADOS.

ES **RESPONSABILIDAD DEL PROPIETARIO / OPERADOR** ASEGURAR EL ENTRENAMIENTO ADECUADO Y LA DILIGENCIA DE CUALQUIER PERSONA QUE ENTRA EN CONTACTO CON LOS HORNO O SU SALIDA. ES RESPONSABILIDAD DEL PROPIETARIO / OPERADOR ASEGURARSE DE QUE EL HORNO SE INSTALE Y FUNCIONE DE ACUERDO CON LA NORMA OSHA 1910.263.

SE DEBE ESTABLECER UN PROGRAMA PERIÓDICO REGULAR DE LIMPIEZA, INSPECCIÓN Y MANTENIMIENTO Y MANTENIMIENTOS INTEGRALES DE MANTENIMIENTO MANTENIDOS. ES **LA RESPONSABILIDAD EXCLUSIVA DEL PROPIETARIO / OPERADOR** ESTABLECER, PROGRAMAR Y EFECTUAR LA FRECUENCIA Y EL ALCANCE DE ESTOS PROGRAMAS AL MANTENERSE CON LA PRÁCTICA RECOMENDADA Y CON LA DEBIDA CONSIDERACIÓN DADA A LAS CONDICIONES OPERATIVAS REALES.

ESTE HORNO DEBE SER OPERADO DENTRO DE LÍMITES, QUE NO EXCEDERÁ SUS LÍMITES DE TRABAJO. ES **RESPONSABILIDAD DEL USUARIO OPERAR** ESTE HORNO DE ACUERDO CON LAS REGLAS Y LÍMITES DESCRITOS EN ESTE MANUAL Y LA HOJA DE ESPECIFICACIONES DEL PRODUCTO PUBLICADO, Y DE ACUERDO CON LAS INSTRUCCIONES Y DIRECCIONES DEL PROPIETARIO / OPERADOR DEL HORNO O EMPLEADOR, Y EN CONFORMIDAD CON LAS LEYES Y ORDENANZAS FEDERALES, ESTATALES Y LOCALES APLICABLES.

Specifications (Gas Ovens) / Specifications / Especificaciones

Model / Modèle / Modelo	H x W x D*	Clearance to Combustibles / Distance aux combustibles / Distancia hasta Combustibles	Weight / Poids / Peso		Class / Classe / Clase
			Actual / Réel / Real	Crated / Crated / Crated	
LRO-1__	105 x 55 x 88" [2654x1397x2235mm]	Sides 0, Back 0 / Flanc 0, Derrière 0 / Costado 0, Parte Posterior 0	2500 lb [1135 kg]	3089 lb [1401 kg]	77.5
LRO-2__	105 x 72 x 108" [2654x1829x2743mm]		3380 lb [1530 kg]	4380 lb [1990 kg]	

Electric Requirements / Exigence Électriques / Requisitos Eléctricos

Model / Modèle / Modelo	Voltage / Tension / Voltaje	kW	Min Circuit Amps / Circuit Min / Circuito Mín	Max Breaker Amps / Disjoncteur de Max / Interruptor de Máx
LRO – G5	120V/208VAC, 3ph, 60Hz ^①	1.8	15	20
	120V/240VAC, 3ph, 60Hz ^①	1.8	15	20
Optional Voltage	120V/240VAC, 1ph, 60Hz ^②	1.8	20	20
	120VAC, 1ph, 60Hz / 480VAC, 3ph, 60Hz	0.8/1.0	15/15	20/20

Gas Requirements / Exigences de Gaz / Requisitos de Gas (NG and LPG)

Model / Modèle / Modelo	Input Rate / Taux d'Entrée / Tasa de Entrada		Input Pressure / Press ion d'entrée / Presión de entrada	Manifold Pressure	Orifices Drill Size		
	kBTU/hr	kCal/hr	Min/Max Natural Gas	Natural Gas/Propane	Natural	Propane	
LRO-1G5-__	175	44	5" / 14" wc [1.2/3.5 kPa]	10"/14" wc [2.5/3.5 kPa]	3.5"/8.5" wc [0.87/2.1 kPa] †	#45	#55
LRO-2G5-__	290	73				#45	#55

Venting / Ventilation / Ventilación

Water / Eau / Agua

Model	CFM M3/Min ‡	Pressure Drop	Eyebrow Hood Type	Input Pressure / Pression d'Entrée / Presión de Entrada
LRO-1__	530 15	1 inwc [250 Pa]	Type II or Type I as required. ‡‡	40 psi [275 kPa] Min; 100 psi [700 kPa] Max
LRO-2__	800 23			

Water Condition / Eau Condition / Agua Condición

Alkalinity < 22 ppm	Magnesium < 0.65 ppm
Aluminum < 17 ppm	pH = 8.5
Calcium < 3.3 ppm	Sodium < 8.5 ppm
Free Chlorine Radical < 0.6 ppm	Total Hardness < 11.9 ppm

① This Connection requires 5 wires: L1, L2, L3, Neutral and Ground.

② This connection requires 4 wires: L1, L2, Neutral and Ground.

* Clearance, tilt up / Dégagement d'incliner / Espacio libre para inclinara = 112" [2845mm]

** Non-combustible floors supported by non-combustible structure /
Planchers combustibles non pris en charge par la structure combustible non /
Pisos no combustibles soportados por la estructura no combustible

‡ See tag on valve / Voir tag sur la valve / Ver tag en la válvula

‡ External roof-top fan required / Externe sur le toit ventilateur requis / Externa en la azotea requiere ventilador

‡‡ Per local Codes / Par codes locaux / Por códigos locales

Specifications (Electric Ovens) / Spécifications / Especificaciones

Model / Modèle / Modelo	H x W x D*	Clearance to Combustibles / Distance aux combustibles / Distancia hasta Combustibles	Weight / Poids / Peso		Class / Classe / Clase
			Actual / Réel / Real	Crated / Crated / Crated	
LRO-1__	105 x 55 x 88" [2654x1397x2235mm]	Sides 0, Back 0 / Flanc 0, Derrière 0 / Costado 0, Parte Posterior 0	2500 lb [1135 kg]	2900 lb [1315 kg]	77.5
LRO-2__	105 x 72 x 108" [2654x1829x2743mm]		3380 lb [1530 kg]	4380 lb [1990 kg]	

Electric Requirements / Exigence Électriques / Requisitos Eléctricos

Model / Modèle / Modelo	Voltage / Tension / Voltaje	kW	Min Circuit Amps / Circuit Min / Circuito Mín	Max Breaker Amps / Disjoncteur de Max / Interruptor de Máx
LRO-1E5	120V/208VAC, 3ph, 60 Hz ^①	41.5	145	175
Optional Voltage	120V/240VAC, 3ph, 60 Hz ^①	41.5	125	150
	120VAC, 1ph, 60Hz ^③ /480VAC, 3ph, 60Hz ^② (Not Available in Canada)	40	15/85	20/100
	480 VAC, 3ph, 60 Hz ^②	40	85	100
LRO-2E5	120V/208VAC, 3ph, 60 Hz ^①	51.6	180	200
Optional Voltage	120V/240VAC, 3ph, 60 Hz ^①	55	165	200
	120VAC, 1ph, 60 Hz ^③ /480VAC, 3ph, 60 Hz ^② (Not Available in Canada)	55	15/85	20/100
	480 VAC, 3ph, 60 Hz ^②	55	85	100

Model	CFM M3/Min ‡	Pressure Drop	Eyebrow Hood Type	Input Pressure / Pression d'Entrée / Presión de Entrada
LRO-1__	530 15	1" wc [250 Pa]	Type II or Type I as required.##	40 psi [275 kPa] Min; 100 psi [700 kPa] Max
LRO-2__	800 23			

Water Condition / Eau Condition / Agua Condición

Alkalinity < 22 ppm	Magnesium < 0.65 ppm
Aluminum < 17 ppm	pH = 8.5
Calcium < 3.3 ppm	Sodium < 8.5 ppm
Free Chlorine Radical < 0.6 ppm	Total Hardness < 11.9 ppm

① This Connection requires 5 wires: L1, L2, L3, Neutral and Ground.

② This connection requires 4 wires: L1, L2, Neutral and Ground.

③ This Connection requires 3 wires: L1, Neutral and Ground.

* **Clearance, tilt up / Dégagement d'incliner / Espacio libre para inclinar = 112" [2845mm]**

** **Non-combustible floors supported by non-combustible structure / Planchers combustibles non pris en charge par la structure combustible non / Pisos no combustibles soportados por la estructura no combustible**

‡ **External roof-top fan required / Externe sur le toit ventilateur requis / Externa en la azotea requiere ventilador**

Per local Codes / Par codes locaux / Por códigos locales

Drawings

LRO-1E/G5

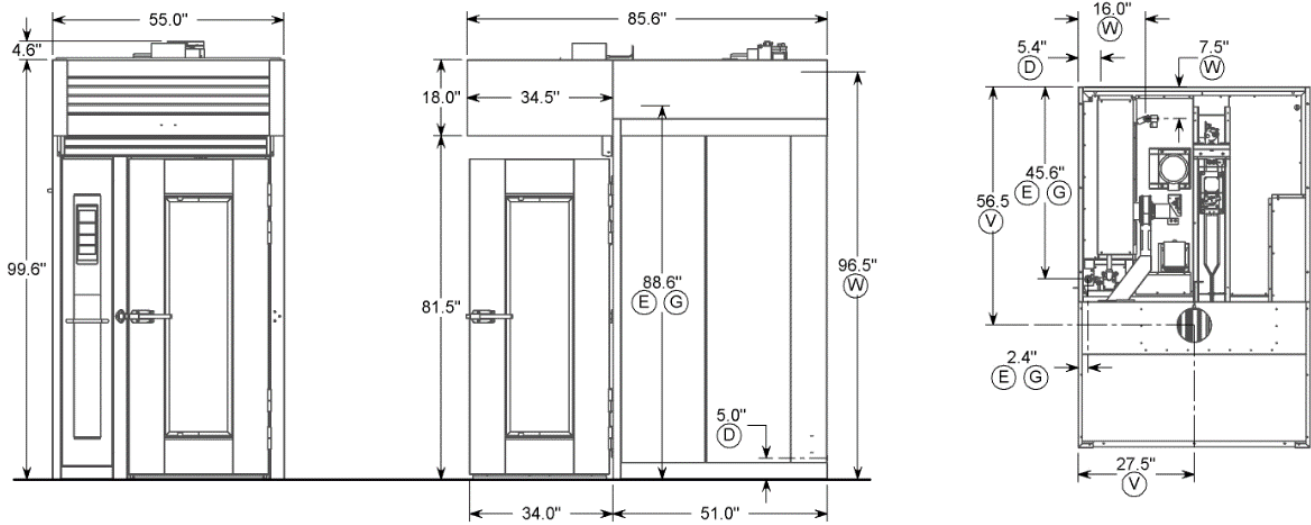

LRO-2E/G5

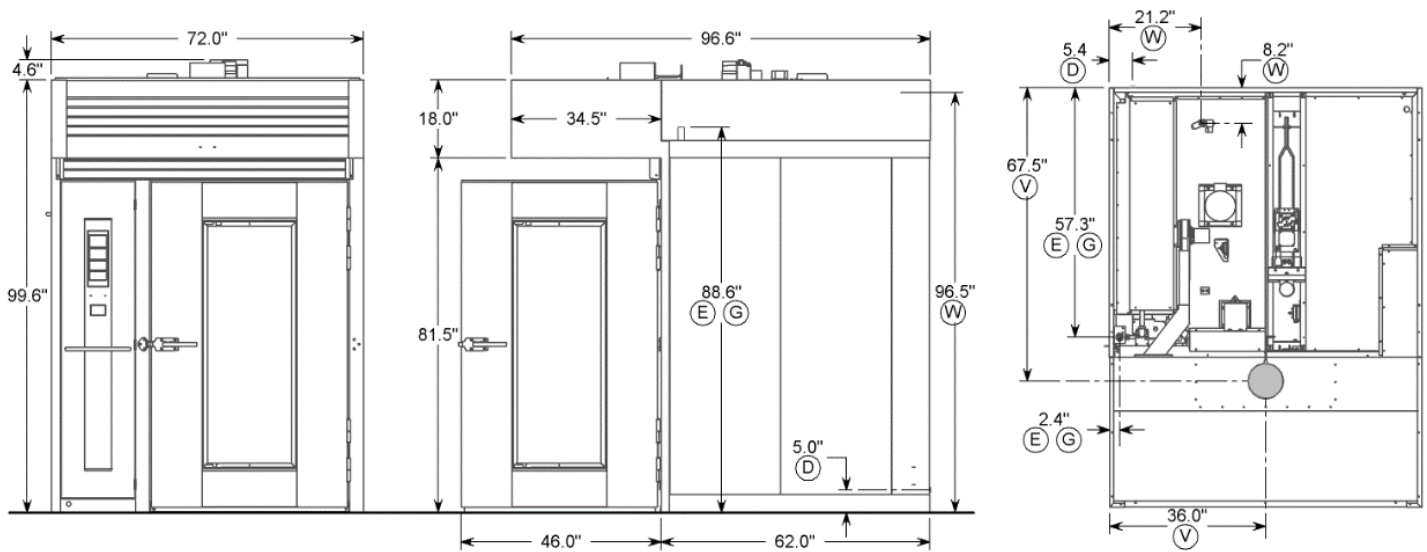

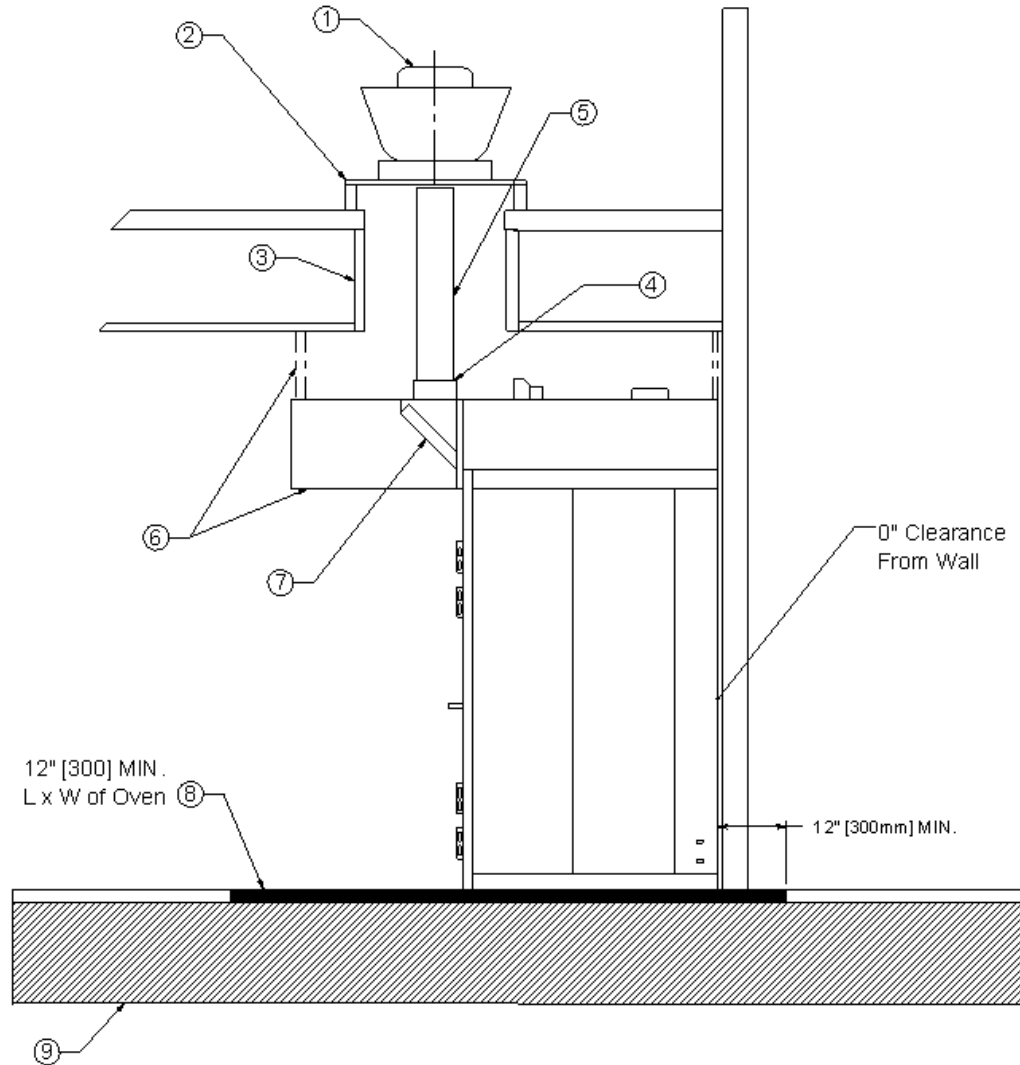

- 1) Roof-top ventilator (not supplied) / *Ventilateur de toit (non fourni) / Ventilador de techo (no suministrado)*
- 2) Riser / *Bordure du Trottoir / Bordillo*
- 3) Pipe space to combustibles / *Espace minimum pour combustibles / Espacio mínimo para combustibles*
If Type I Hood = 18in [460mm]; If Type B Vent = 1in [25mm]
- 4) Air flow switch (supplied) / *Détecteur de débit d'air (fourni) / Interruptor de flujo de aire (suministrado)*
- 5) Duct (not supplied) / *Conduit (non fourni) / Duct (no suministrado)*
- 6) If enclosed, the top of the oven must be vented to the room / *Si clos, en haut de la four doit être ventilé de la salle / Si está cerrado, la parte superior del horno debe ser ventilada a la habitación*
- 7) Grease filters (supplied) / *Filtres à graisse (fourni) / Filtros de grasa (suministrado)*
- 8) Non-combustible floor & support / *Incombustible plancher & support / Incombustible piso y el apoyo*
- 9) No pipes or wires / *Pas de tuyaux ou de fils / Sin tuberías ni cables*

Conditions of Installation / 'Les conditions d'Installation / Condiciones la Instalación

CAUTION

Rack ovens are large and require special handling equipment. Rack ovens cannot be off-loaded from a liftgate truck without a fork lift. Door openings to the site must be big enough for the crates.

Responsibility of the Customer

1. Obtain all required permits and license
2. The floor must be clear and level
3. The pathway must be clear and ready for passage of the oven sections
4. Electrical, Gas, Water, Drain and Ventilation should be installed to within 5' of the oven
5. A Qualified Electrician, Plumber and Ventilation mechanic should be ready to make connections
6. Be sure that there is room to tilt the oven up and have room for access to the top
7. Be sure make-up air is adequate to supply 85% of the air vented through the hood
8. Remove all trash and crating from the work area
9. Provide all outer trim and metal work required by local codes

ATTENTION

Les fours à crémaillère sont grands et nécessitent un équipement de manutention spécial. Les fours à crémaillère ne peuvent pas être déchargés d'un camion sans hayon élévateur. Les ouvertures de portes du site doivent être suffisamment grandes pour les caisses.

Responsabilité du client

1. Obtenir tous les permis et licences requis.
2. Le sol doit être clair et horizontal.
3. La voie doit être claire et prête pour le passage des sections du four.
4. L'électricité, le gaz, l'eau, le drain et la ventilation doivent être installés à moins de 1.5 metre du four.
5. Un électricien qualifié, plombier et mécanicien de ventilation devrait être prêt à faire des connexions.
6. Assurez-vous qu'il y a de la place pour incliner le four et avoir de la place pour accéder au haut.
7. Assurez-vous que l'air d'appoint est suffisant pour alimenter 85% de l'air ventilé à travers la hotte.
8. Retirez toutes les ordures et les caisses de la zone de travail.
9. Fournir toute la garniture extérieure et le travail du métal requis par les codes locaux.

PRECAUCIÓN

Los hornos de estantes son grandes y requieren un equipo de manejo especial. Los hornos Rack no se pueden descargar desde un camión con puerta levadiza sin una carretilla elevadora. Las aberturas de las puertas del sitio deben ser lo suficientemente grandes para las cajas.

Responsabilidad del cliente

1. Obtenga todos los permisos y licencias requeridos.
2. El piso debe estar despejado y nivelado.
3. El camino debe estar despejado y listo para el paso de las secciones del horno.
4. Eléctrico, Gas, Agua, Drenaje y Ventilación deben instalarse a 1.5 metre o menos del horno.
5. Un mecánico calificado de electricista, fontanero y ventilación debe estar listo para hacer las conexiones.
6. Asegúrese de que haya espacio para la habitación y acceso a la parte superior.
7. Asegúrese de que el aire de reposición sea adecuado para suministrar el 85% del aire ventilado a través de la campana.
8. Retire toda la basura y embalaje del área de trabajo.
Proporcione todos los códigos locales requeridos.

Must Read! (English)

WARNING

INSTALLATION OF THE UNIT MUST BE DONE BY PERSONNEL QUALIFIED TO WORK WITH ELECTRICITY AND PLUMBING. IMPROPER INSTALLATION CAN CAUSE INJURY TO PERSONNEL AND/OR DAMAGE TO EQUIPMENT. UNIT MUST BE INSTALLED IN ACCORDANCE WITH ALL APPLICABLE CODES.

WARNING

DO NOT ALLOW ANY PART OF YOUR BODY TO BE UNDER THE OVEN DURING THE LIFTING PROCESS. KEEP EVERYONE CLEAR FROM THE OVEN IF IT SHOULD FALL.

WARNING

THIS LBC BAKERY OVEN PRODUCES HUMIDITY THAT CAN CAUSE THE INTERIOR FLOORING AND ADJACENT EXTERIOR FLOORING TO BECOME SLIPPERY. USE EXTREME CAUTION WHEN WALKING ON A WET OR DAMP FLOOR.

WARNING

WHEN THE LOADING DOOR IS OPENED, HOT AIR AND STEAM ARE RELEASED FROM THE OVEN INTERIOR. TO AVOID BURNS OPEN DOOR SLOWLY AND KEEP YOUR FACE AND HANDS CLEAR OF THE OPENING. ALL INTERIOR SURFACES ARE VERY HOT. DO NOT TOUCH ANYTHING WITHOUT OVEN MITTS.

WARNING

THE THERMAL OVERLOAD RELAYS FOR THE CIRCULATION BLOWER MOTOR AND THE LIFTER / ROTATOR MOTOR ARE RESET AUTOMATICALLY. ALL POWER TO THE OVEN MUST BE TURNED OFF BEFORE SERVICING.

WARNING

THE WATER FROM THE STEAM DRAIN OUTLET IS EXTREMELY HOT AND MAY CAUSE SERIOUS BURNS.

WARNING

WIRES ENTERING THE DISCONNECT MAY STILL BE LIVE EVEN WHEN THE SWITCH IS TURNED OFF. SWITCH THE MAIN BREAKER AT THE WALL TO "OFF" WHEN SERVICING THE OVEN.

CAUTION: INSTALLATION MUST CONFORM WITH LOCAL CODES OR IN THE ABSENCE OF LOCAL CODES THE NATIONAL FUEL GAS CODE, ANSIZ223.11996.

CAUTION: THIS APPLIANCE, WHEN INSTALLED, MUST BE ELECTRICALLY GROUNDED IN ACCORDANCE WITH LOCAL CODES, OR IN THE ABSENCE OF LOCAL CODES, WITH THE NATIONAL ELECTRICAL CODE, ANSI/NFPA 70-1996.

CAUTION: FOR INSTALLATION IN CANADA THE INSTALLATION MUST BE IN ACCORDANCE WITH CAN/CGA-B149.1&2 OF THE INSTALLATION CODE, AND LOCAL CODES WHERE APPLICABLE. ALL ELECTRIC

WIRING MUST BE IN ACCORDANCE WITH THE CURRENT CANADIAN ELECTRICAL CODE, C22.1 PART 1.
GROUNDING THIS APPLIANCE MUST CONFORM TO CANADIAN ELECTRICAL CODE, CSA C22.2.

CAUTION: TO REDUCE THE RISK OF FIRE, THE APPLIANCE IS TO BE MOUNTED ON FLOORS OF NON-COMBUSTIBLE CONSTRUCTION WITH NONCOMBUSTIBLE FLOORING, SURFACE FINISH AND WITH NO COMBUSTIBLE MATERIAL AGAINST THE UNDERSIDE THEREOF, OR ON NON-COMBUSTIBLE SLABS OR ARCHES HAVING NO COMBUSTIBLE MATERIAL AGAINST THE UNDERSIDE. SUCH CONSTRUCTION SHALL EXTEND A MINIMUM OF 12 INCHES BEYOND THE EQUIPMENT ON ALL SIDES.

CAUTION: CAUTION SHOULD BE TAKEN WHEN ENCLOSING HOOD TO CEILING AND OVEN IS UNDER A FIRE SPRINKLER; HOOD EXHAUST STACK WILL EMIT HEAT.

NOTICE: No other exhaust systems may be connected to this system. Do not try to vent or exhaust another appliance into this hood.

NOTICE: Do not allow more than 14 inches pressure to be applied to the gas valve at any time.

NOTICE: Service on this, or any other, LBC BAKERY appliance must be performed by qualified personnel only. Consult your authorized service agency directory or call the factory at 888-722-5686 or go to www.lbcbakery.com for the service agent nearest you.

NOTICE: To maintain optimum safety and performance for LBC BAKERY ovens, it is recommended that a program of scheduled periodic maintenance be implemented. It is sole responsibility of the user to establish, schedule and enforce such a program. The actual service interval will vary depending on the environment.

NOTICE: Depending on the environment in which the equipment is operating, it is recommended that preventative maintenance be done by an LBC Bakery authorized service agency at least every 6 months.

NOTICE: The ambient temperature outside the oven should not exceed 104 deg F. This includes the temperature of the air above and around the oven.

NOTICE: During the first few hours of operation you may notice a small amount of smoke coming off of the oven, and a faint odor from the smoke. This is normal for a new oven and will disappear after the first few hours of use.

Doit lire! (Français)

ATTENTION

L'INSTALLATION DE L'UNITÉ DOIT ÊTRE EFFECTUÉE PAR DU PERSONNEL QUALIFIÉ POUR TRAVAILLER AVEC L'ÉLECTRICITÉ ET LA PLOMBERIE. UNE INSTALLATION INCORRECTE PEUT CAUSER DES BLESSURES AU PERSONNEL ET / OU ENDOMMAGER L'ÉQUIPEMENT. L'UNITE DOIT ETRE INSTALLEE CONFORMEMENT A TOUS LES CODES APPLICABLES.

ATTENTION

NE PAS LAISSER AUCUNE PARTIE DE VOTRE CORPS POUR ÊTRE SOUS LE FOUR PENDANT LE PROCESSUS DE LEVAGE. GARDEZ TOUT LE MONDE FORMULAIRE DE CLAIR DU FOUR EN CAS DE CHUTE.

ATTENTION

CE FOUR DE BOULANGERIE LBC PRODUIT DE L'HUMIDITÉ QUI PEUVENT CAUSER LA SOLS INTÉRIEURS ET SOLS EXTÉRIEURS ADJACENTS QUI PEUVENT DEVENIR GLISSANTES. SOYEZ EXTRÊMEMENT PRUDENT LORSQUE MARCHE SUR UN PLANCHER MOUILLÉ OU HUMIDE.

ATTENTION

QUAND LA PORTE DE CHARGEMENT EST OUVERTE, AIR CHAUD ET VAPEUR SONT LIBÉRÉS DE L'INTÉRIEUR DU FOUR. POUR ÉVITER LES BRÛLURES PORTE OUVERTE LENTEMENT ET GARDEZ VOTRE VISAGE ET MAINS À L'ÉCART DE L'OUVERTURE. TOUTES LES SURFACES INTÉRIEURES SONT TRÈS CHAUDS. NE TOUCHEZ À RIEN, SANS GANTS DE CUISINE.

ATTENTION

LES RELAIS DE SURCHARGE THERMIQUE DU MOTEUR VENTILATEUR DE CIRCULATION ET LE MOTEUR LEVE / MOTEUR ROTATEUR SONT REMIS À ZÉRO AUTOMATIQUEMENT. TOUT LE POUVOIR AUX FOUR DOIT ÊTRE ÉTEINT AVANT L'ENTRETIEN.

ATTENTION L'EAU DE LA PRISE DE DRAIN DE VAPEUR EST EXTRÊMEMENT CHAUD ET PEUT PROVOQUER DE GRAVES BRÛLURES.

ATTENTION

ATTENTION IL FAUT PRENDRE QUAND ENCLOSE HOTTE AU PLAFOND ET FOUR EST EN VERTU D'UNE GICLEURS D'INCENDIE; PILE HOTTE NE ÉMETTENT DE LA CHALEUR.

PRUDENCE: INSTALLATION DOIT ÊTRE CONFORME AUX CODES LOCAUX OU EN L'ABSENCE DE CODES LOCAUX DU NATIONAL FUEL GAS CODE, ANSI Z223.11996.

PRUDENCE: CET APPAREIL LORSQUE INSTALLÉ, DOIT ÊTRE À LA TERRE CONFORMÉMENT AUX CODES LOCAUX, OU EN L'ABSENCE DE CODES LOCAUX, AVEC LE NATIONAL ELECTRICAL CODE ANSI / NFPA 70-1996.

PRUDENCE: POUR INSTALLATION AU CANADA L'INSTALLATION DOIT ÊTRE EN CONFORMITÉ AVEC CAN/CGA-B149.1 & 2 DU CODE INSTALLATION ET CODES LOCAUX SI APPLICABLES. TOUT LE CÂBLAGE ÉLECTRIQUE DOIT ÊTRE EN CONFORMITÉ AVEC LE CODE COURANT ÉLECTRIQUE CANADIEN, C22.1, PARTIE 1. TERRE CET APPAREIL DOIT SE CONFORMER AU CODE CANADIEN DE L'ÉLECTRICITÉ, CSA C22.2.

PRUDENCE: POUR RÉDUIRE LE RISQUE D'INCENDIE, L'APPAREIL DOIT ÊTRE MONTÉ SUR DES PLANCHERS DE CONSTRUCTION NON COMBUSTIBLE AVEC PLANCHER NON COMBUSTIBLE, FINI DE SURFACE ET SANS MATÉRIAU COMBUSTIBLE CONTRE LE SOUS-SOL OU SUR DES DALLES OU DES ARCHES NON COMBUSTIBLES N'AYANT AUCUN MATÉRIAU COMBUSTIBLE CONTRE LE FEU DESSOUS. CETTE CONSTRUCTION S'ÉTEND AU MINIMUM DE 12 POUCHES AU-DELÀ DE L'ÉQUIPEMENT DE TOUS LES CÔTÉS.

PRUDENCE: ATTENTION IL FAUT PRENDRE QUAND ENCLOSE HOTTE AU PLAFOND ET FOUR EST EN VERTU D'UNE GICLEURS D'INCENDIE; PILE HOTTE NE ÉMETTENT DE LA CHALEUR.

AVIS: Aucun système d'échappement peut être raccordé à ce système. Ne pas essayer d'évacuer ou d'épuiser un autre appareil dans cette hotte.

AVIS: Ne permettent pas plus de 14 pouces (3,5 kPa) de pression à appliquer à la soupape à gaz, à tout moment.

AVIS: Service à ce sujet, ou tout autre appareil LBC Bakery doit être effectuée par du personnel qualifié. Consultez votre annuaire de service autorisé ou appeler l'usine au 888-722-5686 ou consultez le site www.lcbakery.com pour l'agent sde servise le plus proche.

AVIS: Pour maintenir la sécurité et des performances optimales pour les modèles LBC Fours de boulangerie, il est recommandé qu'un programme d'entretien périodique prévu être mis en oeuvre. C'est la seule responsabilité de l'utilisateur de créer, planifier et mettre en ouvre un tel programme. Bien que l'intervalle de service réele peut varier selon l'environnement dans lequel l'appareil est en marche, il est recommandé ce qui suit sera faite par un boulangerie LBC Centre de Service Autorisé au moins tou les 6 mois.

AVIS: En fonction de l'environnement dans lequel l'équipement fonctionne, il est recommandé que l'entretien préventif soit effectué par une agence de maintenance agréée LBC Bakery au moins tous les 6 mois.

AVIS: La température ambiante à l'extérieur du four ne doit pas dépasser 40 degrés C. Cela inclut la température de l'air au-dessus et autour du four.

AVIS: Au cours des premières heures de fonctionnement, vous remarquerez peut-être une petite quantité de fumée provenant du four et une légère odeur de la fumée. Ceci est normal pour un nouveau four et disparaîtra après les premières heures d'utilisation.

Debe leer! (Español)

ADVERTENCIA

LA INSTALACIÓN DE LA UNIDAD DEBE SER REALIZADA POR PERSONAL CUALIFICADO PARA TRABAJAR CON ELECTRICIDAD Y PLOMERÍA. LA INSTALACIÓN INCORRECTA PUEDE CAUSAR LESIONES AL PERSONAL Y / O DAÑOS AL EQUIPO. LA UNIDAD DEBE INSTALARSE DE ACUERDO CON TODOS LOS CÓDIGOS APLICABLES.

ADVERTENCIA

NO PERMITA QUE CUALQUIER PARTE DEL CUERPO SE ENCUENTRE BAJO EL HORNO DURANTE EL PROCESO DE ELEVACIÓN. MANTENGA A TODOS LIMPIOS AL HORNO SI DEBERÍA CAER.

ADVERTENCIA

ESTE HORNO DE PANADERÍA LBC PRODUCE HUMEDAD QUE PUEDE CAUSAR QUE EL SUELO INTERIOR Y EL SUELO EXTERIOR ADYACENTE SE VUELVEN RESBALADIZOS. TENGA EXTREMA PRECAUCIÓN AL CAMINAR EN UN PISO HÚMEDO O AMURRIDO.

ADVERTENCIA

CUANDO SE ABRE LA PUERTA DE CARGA, SE LIBERA EL AIRE CALIENTE Y EL VAPOR DEL INTERIOR DEL HORNO. PARA EVITAR QUEMADURAS, ABRA LA PUERTA LENTAMENTE Y MANTENGA SU CARA Y LAS MANOS ALEJADAS DE LA ABERTURA. TODAS LAS SUPERFICIES INTERIORES ESTAN MUY CALIENTES. NO TOQUE NINGUNO SIN HORQUILLAS.

ADVERTENCIA

LOS RELÉS DE SOBRECARGA TÉRMICA PARA EL MOTOR DEL CIRCULADOR Y EL MOTOR DEL ELEVADOR / ROTADOR SE REINICIAN AUTOMÁTICAMENTE. TODA LA ENERGÍA AL HORNO DEBE APAGARSE ANTES DE REALIZAR EL SERVICIO.

ADVERTENCIA

EL AGUA DE LA SALIDA DE DRENAJE DE VAPOR EXTREMADAMENTE CALIENTE Y PUEDE CAUSAR QUEMADURAS GRAVES.

ADVERTENCIA

LOS ALAMBRES QUE ENTRAN EN LA DESCONEXIÓN PUEDEN TODAVÍA VIVIR AUN CUANDO EL INTERRUPTOR ESTÁ APAGADO. APAGUE EL INTERRUPTOR PRINCIPAL EN LA PARED PARA DESCONECTARLO AL MANTENIMIENTO DEL HORNO.

PRECAUCIÓN: LA INSTALACIÓN DEBE CONFORMARSE CON LOS CÓDIGOS LOCALES O, EN AUSENCIA DE CÓDIGOS LOCALES, EL CÓDIGO NACIONAL DE GASOLINA DE COMBUSTIBLE, ANSI Z223.11996.

PRECAUCIÓN: ESTA APLICACIÓN, CUANDO SE INSTALA, DEBE CONECTAR A TIERRA ELÉCTRICA DE ACUERDO CON LOS CÓDIGOS LOCALES, O EN AUSENCIA DE CÓDIGOS LOCALES, CON EL CÓDIGO ELÉCTRICO NACIONAL, ANSI / NFPA 70-1996.

PRECAUCIÓN: PARA LA INSTALACIÓN EN CANADÁ, LA INSTALACIÓN DEBE ESTAR DE ACUERDO CON CAN / CGA-B149.1 Y 2 DEL CÓDIGO DE INSTALACIÓN, Y LOS CÓDIGOS LOCALES DONDE CORRESPONDA. TODOS LOS CABLEADOS ELÉCTRICOS DEBEN RESPETARSE CON EL CÓDIGO ELÉCTRICO CANADIENSE ACTUAL, C22.1 PARTE 1. PUESTA A TIERRA ESTE APARATO DEBE CONFORMARSE CON EL CÓDIGO ELÉCTRICO CANADIENSE, CSA C22.2.

PRECAUCIÓN: PARA REDUCIR EL RIESGO DE INCENDIO, EL APARATO SE MONTARÁ EN SUELOS DE CONSTRUCCIÓN NO COMBUSTIBLE CON PISOS NO COMBUSTIBLES, ACABADOS DE SUPERFICIE Y SIN MATERIAL COMBUSTIBLE CONTRA EL SUJETO, O SOBRE LOSAS O ARCOS NO COMBUSTIBLES QUE NO TENGAN MATERIAL COMBUSTIBLE CONTRA EL ENVÉS. DICHA CONSTRUCCIÓN DEBERÁ EXTENDER UN MÍNIMO DE 12 PULGADAS MÁS ALLÁ DEL EQUIPO EN TODOS LOS LADOS.

PRECAUCIÓN: SE DEBE TENER CUIDADO AL ENTREGAR LA CAMPANA AL TECHO Y EL HORNO ESTÁ DEBAJO DEL ROCIADOR; LA PILA DE ESCAPE DE LA CAMPANA EMITIRÁ CALOR.

AVISO: No se pueden conectar otros sistemas de escape a este sistema. No intente enrollar o agotar otro electrodoméstico en esta campana.

AVISO: No permita que se apliquen más de 14 pulgadas a la válvula de gas en ningún momento.

AVISO: El servicio en este, o en cualquier otro, dispositivo LBC BAKERY debe ser realizado únicamente por personal calificado. Consulte a su agencia de servicio autorizado o comuníquese con la fábrica al 888-722-5686 o visite www.lcbakery.com para obtener el servicio más cercano.

AVISO: Para mantener un rendimiento y rendimiento óptimos para los hornos LBC BAKERY, se recomienda implementar un programa de mantenimiento periódico programado. Es responsabilidad del usuario establecer, programar y hacer cumplir dicho programa. El intervalo de servicio real variará según el entorno.

AVISO: Dependiendo del ambiente, se recomienda que se recomiende que se le autorice a LBC Bakery por lo menos cada 6 meses.

AVISO: La temperatura ambiente fuera del horno no debe exceder los 40 grados C. Esto incluye la temperatura del aire sobre y alrededor del horno.

AVISO: Durante las primeras horas de operación, una pequeña cantidad de humo del horno y un leve olor a humo. Esto es normal para un horno nuevo y desaparecerá después de las primeras horas de uso.

Assembly (English)

See Oven Assembly Instructions insert.

Assemblée (Français)

Voir la notice d'instructions de montage du four.

Asamblea (Español)

Ver inserción de las instrucciones de montaje del horno.

Electrical Connections (Gas)

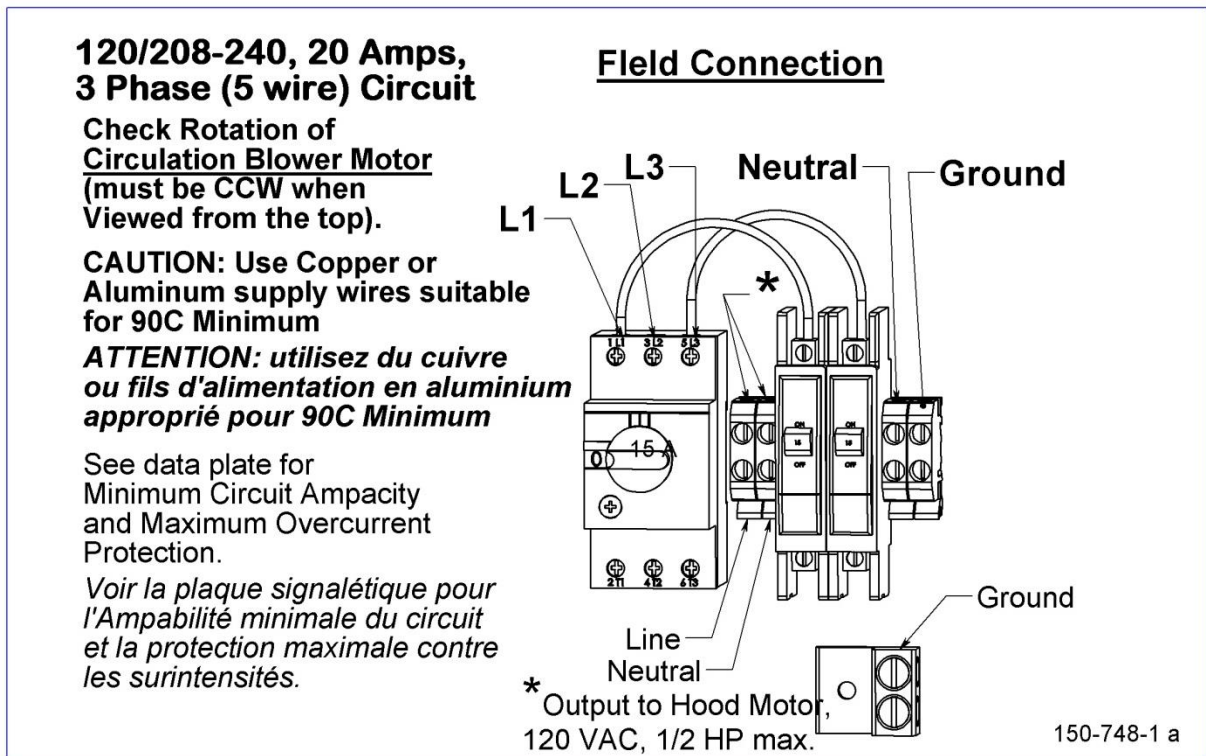

Note: The electrical connection for gas ovens requires a single supply for the circulation motor and the control circuit. This is important so that the oven will not operate without the circulation motor running.

Remarque: Le raccordement électrique des fours à gaz nécessite une alimentation unique pour le moteur de circulation et le circuit de commande. Ceci est important pour que le four ne fonctionne pas sans le moteur de circulation en marche.

Nota: La conexión eléctrica para hornos de gas requiere una sola fuente para el tráfico del motor y el circuito de control. Esto es importante para que el horno no funcione sin el motor en funcionamiento.

Electrical Connections (Electric 208-240 Volt)

LRO-1E

LRO-2E

Hood Ventilator Output
Connexion
d'alimentation du
ventilateur
Conexión de potencia
del ventilador
 (1/2 Hp Maximum, 120 VAC)

Power Input
Entrée électrique
Entrada eléctrica
 (See data plate
 for circuit sizes)

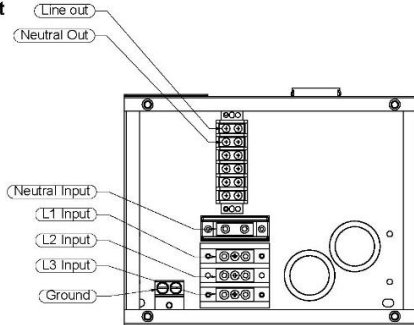

Use Wires Suitable for 90 deg C Min.
 Utilisez des Câbles Appropriate pour 90 deg C Min.
 Utilice cables adecuados para 90 deg C Min.

Power Input
Entrée électrique
Entrada eléctrica
 (See data plate
 for circuit sizes)

Hood Ventilator Output
Connexion
d'alimentation du
ventilateur
Conexión de potencia
del ventilador
 (1/2 Hp Maximum, 120 VAC)

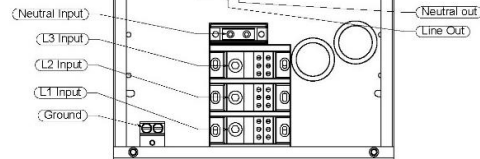

Use Wires Suitable for 90 deg C Min.
 Utilisez des Câbles Appropriate pour 90 deg C Min.
 Utilice cables adecuados para 90 deg C Min.

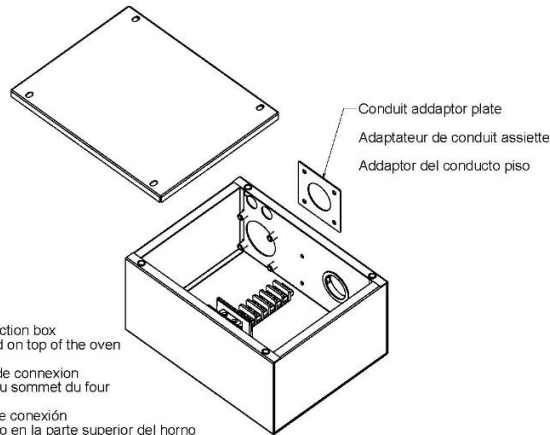

Connection box
 located on top of the oven
 Boîte de connexion
 situé au sommet du four
 Caja de conexión
 ubicado en la parte superior del horno

Electrical Connections (480 Volt Electric)

For US only

LRO-1E

LRO-2E

Hood Ventilator Output
Connexion
d'alimentation du
ventilateur
Conexión de potencia
del ventilador
(1/2 Hp Maximum, 120 VAC)

Power Input
Entrée électrique
Entrada eléctrica
(See data plate
for circuit sizes)

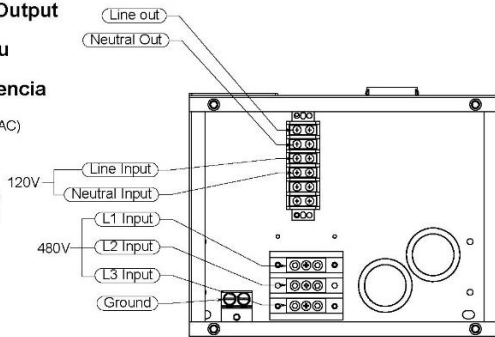

Use Wires Suitable for 90 deg C Min.
Utilisez des Câbles Appropriés pour 90 deg C Min.
Utilice cables adecuados para 90 deg C Min.

Power Input
Entrée électrique
Entrada eléctrica
(See data plate
for circuit sizes)

Hood Ventilator Output
Connexion
d'alimentation du
ventilateur
Conexión de potencia
del ventilador
(1/2 Hp Maximum, 120 VAC)

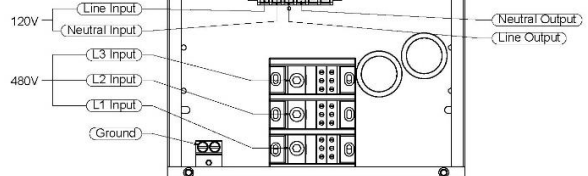

Use Wires Suitable for 90 deg C Min.
Utilisez des Câbles Appropriés pour 90 deg C Min.
Utilice cables adecuados para 90 deg C Min.

For Canada only

LRO-1E

LRO-2E

Power Input
Entrée électrique
(See data plate
for circuit sizes)

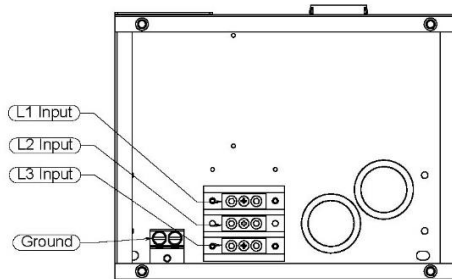

Use Wires Suitable for 90 deg C Min.
Utilisez des Câbles Appropriés pour 90 deg C Min.

Note: This service is connected to a 480/120 VAC 1KVA transformer mounted below.
Remarque: Ce service est connecté à un transformateur 480/120 VAC 1KVA monté ci-dessous.

Power Input
Entrée électrique
(See data plate
for circuit sizes)

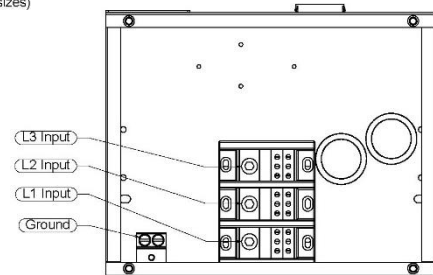

Use Wires Suitable for 90 deg C Min.
Utilisez des Câbles Appropriés pour 90 deg C Min.

Note: This service is connected to a 480/120 VAC 1KVA transformer mounted below.
Remarque: Ce service est connecté à un transformateur 480/120 VAC 1KVA monté ci-dessous.

Gas Connection (English)

LRO-1G5 and LRO-2G5 ovens can operate on Natural Gas or Propane Gas. Refer to the data plate for the type of gas to which the oven is configured.

Gas supply pressure should be within the following pressures:

- Natural Gas: 5" Minimum, 14" Maximum.
- Propane Gas: 10" Minimum, 14" Maximum.

Supply lines to the oven should be large enough to supply the pressure required at the heating rate of the oven. The minimum size for gas lines is 1" NPT. A short flexible connection to the oven is recommended in order to minimize the stress fittings and threaded connections.

CAUTION: THIS APPLIANCE, WHEN INSTALLED, MUST BE ELECTRICALLY GROUNDED IN ACCORDANCE WITH LOCAL CODES, OR IN THE ABSENCE OF LOCAL CODES, WITH THE NATIONAL ELECTRICAL CODE, ANSI/NFPA 70-1996.

CAUTION: FOR INSTALLATION IN CANADA THE INSTALLATION MUST BE IN ACCORDANCE WITH CAN/CGA-B149.1&2 OF THE INSTALLATION CODE, AND LOCAL CODES WHERE APPLICABLE. ALL ELECTRIC WIRING MUST BE IN ACCORDANCE WITH THE CURRENT CANADIAN ELECTRICAL CODE, C22.1 PART 1. GROUNDING THIS APPLIANCE MUST CONFORM TO CANADIAN ELECTRICAL CODE, CSA C22.2.

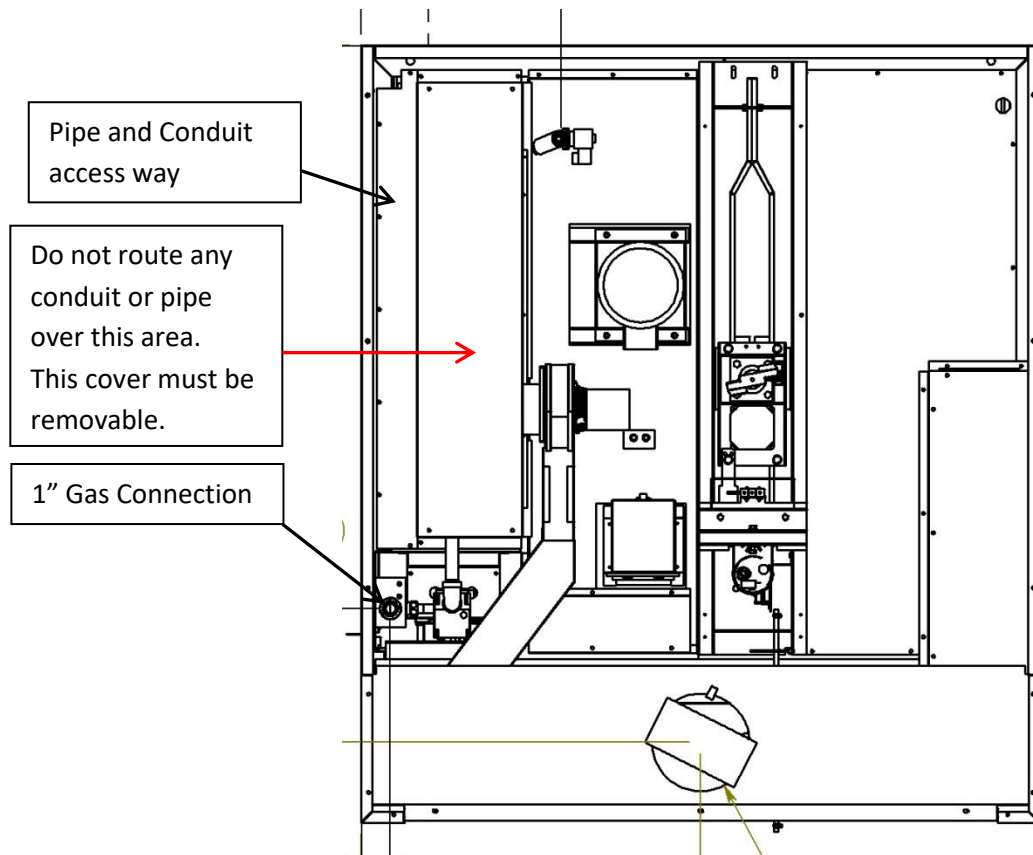

Connexion au gaz (Français)

Les fours LRO-1G5 et LRO-2G5 peuvent fonctionner au gaz naturel ou au gaz propane. Reportez-vous à la plaque signalétique pour le type de gaz sur lequel le four est configuré.

La pression d'alimentation en gaz doit être sous les pressions suivantes:

- Gaz naturel: 5 "minimum, 14" maximum.
- Gaz propane: 10 "minimum, 14" maximum.

Les conduites d'alimentation du four doivent être suffisamment grandes pour fournir la pression nécessaire à la vitesse de chauffage du four. La taille minimale pour les conduites de gaz est de 1 "NPT. Une connexion courte et flexible au four est recommandée afin de minimiser les raccords de contrainte et les raccords filetés.

PRUDENCE: CET APPAREIL LORSQUE INSTALLÉ, DOIT ÊTRE À LA TERRE CONFORMÉMENT AUX CODES LOCAUX, OU EN L'ABSENCE DE CODES LOCAUX, AVEC LE NATIONAL ELECTRICAL CODE ANSI / NFPA 70-1996.

PRUDENCE: POUR INSTALLATION AU CANADA L'INSTALLATION DOIT ÊTRE EN CONFORMITÉ AVEC CAN/CGA-B149.1 & 2 DU CODE INSTALLATION ET CODES LOCAUX SI APPLICABLES. TOUT LE CÂBLAGE ÉLECTRIQUE DOIT ÊTRE EN CONFORMITÉ AVEC LE CODE COURANT ÉLECTRIQUE CANADIEN, C22.1, PARTIE 1. TERRE CET APPAREIL DOIT SE CONFORMER AU CODE CANADIEN DE L'ÉLECTRICITÉ, CSA C22.2.

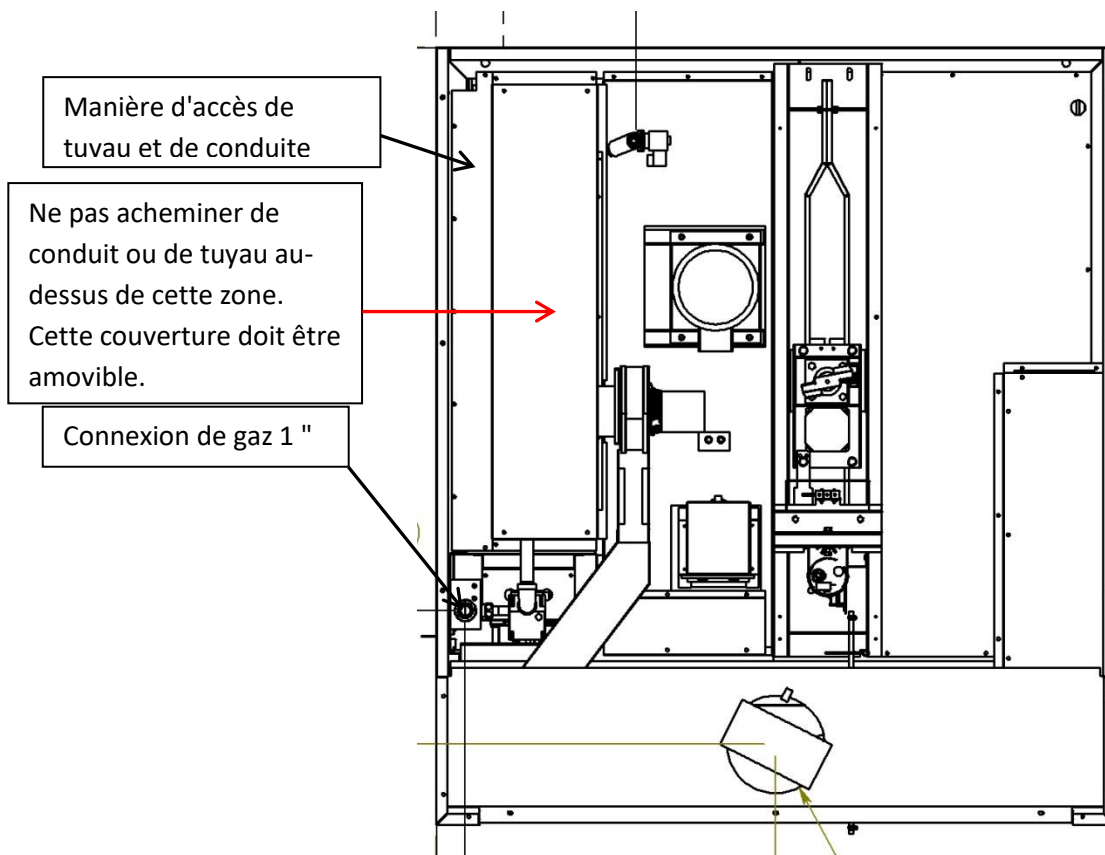

Conexión de gas (Español)

Los hornos LRO-1G5 y LRO-2G5 pueden operar con Gas Natural o Gas Propano. Consulte la placa de datos para conocer el tipo de gas al que está configurado el horno.

La presión del suministro de gas debe estar dentro de las siguientes presiones:

- Gas natural: 5 "mínimo, 14" máximo.
- Gas Propano: 10 "Mínimo, 14" Máximo.

Las líneas de suministro al horno deben ser lo suficientemente grandes como para suministrar la presión requerida a la velocidad de calentamiento del horno. El tamaño mínimo para líneas de gas es 1 "NPT. Se recomienda una conexión corta y flexible al horno para minimizar los accesorios de tensión y las conexiones roscadas.

PRECAUCIÓN: ESTA APLICACIÓN, CUANDO SE INSTALA, DEBE CONECTAR A TIERRA ELÉCTRICA DE ACUERDO CON LOS CÓDIGOS LOCALES, O EN AUSENCIA DE CÓDIGOS LOCALES, CON EL CÓDIGO ELÉCTRICO NACIONAL, ANSI / NFPA 70-1996.

PRECAUCIÓN: PARA LA INSTALACIÓN EN CANADÁ, LA INSTALACIÓN DEBE ESTAR DE ACUERDO CON CAN / CGA-B149.1 Y 2 DEL CÓDIGO DE INSTALACIÓN, Y LOS CÓDIGOS LOCALES DONDE CORRESPONDA. TODOS LOS CABLEADOS ELÉCTRICOS DEBEN RESPETARSE CON EL CÓDIGO ELÉCTRICO CANADIENSE ACTUAL, C22.1 PARTE 1. PUESTA A TIERRA ESTE APARATO DEBE CONFORMARSE CON EL CÓDIGO ELÉCTRICO CANADIENSE, CSA C22.2.

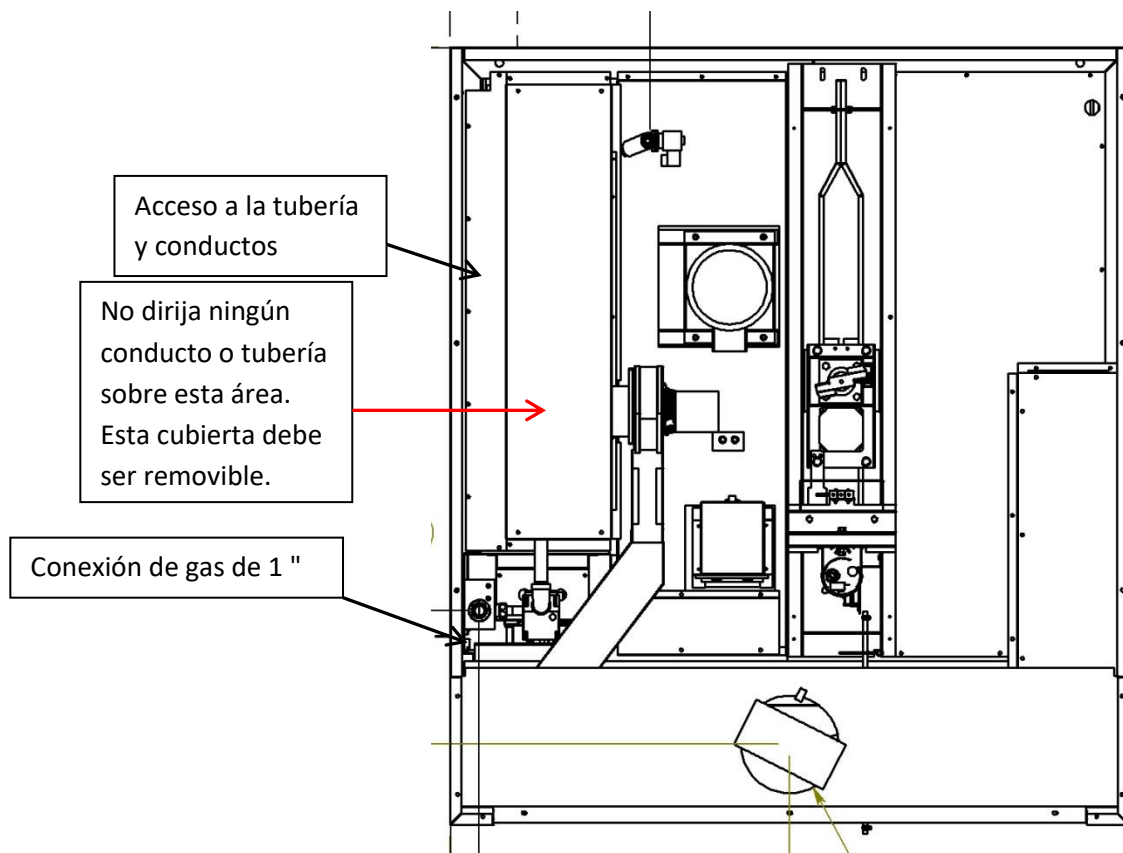

Start-Up Instructions

LBC BAKERY EQUIPMENT, INC. - LRO RACK OVEN STARTUP FORM

This form **MUST BE SIGNED & RETURNED** to LBC at service@lcbakery.com or faxed to (425)642-8310 in order for warranty coverage to become effective. If submitting via email, either scan completed form or carefully photograph each page for submission.

REQUIRED TOOLS/METERS: manometer, multi-meter, amp-clamp, combustion meter/gas analyzer, 6' ladder, variety of standard and metric hand tools (including allen wrenches).

****IF ANYTHING PREVENTS A SUCCESSFUL AND COMPLETE STARTUP, CALL LBC IMMEDIATELY WHILE ONSITE at (888)722-5686****

Serial Number _____
 Model Number _____
 Location Name _____
 Address _____
 City, State _____

Include photos of the following with this startup form:

- 1 Any visible damage _____
- 2 Data plate _____
- 3 Power connection (inside the oven connection box) _____
- 4 Water supply system (i.e., filters, RO system, etc.) _____
- 5 Gas supply pipe (must be 1" black pipe; MUST NOT PREVENT ACCESS TO BURNER COVER!) _____
- 6 Water pressure gauge with water to oven turned "ON" _____
- 7 Drain pipe as it terminates into floor drain _____
- 8 Oven as installed, including area above oven and areas surrounding oven _____

Location Details:

- 1 Confirm oven is on a NON-COMBUSTIBLE floor. IF NOT, CALL LBC!!! _____
- 2 Confirm no utilities are known to be under the oven. IF UTILITIES EXIST BENEATH THE OVEN, CALL LBC. _____
- 3 Confirm oven is level. IF NOT, CALL LBC. _____
- 4 Confirm there is a minimum of 3' above the oven (including above false ceiling). IF NOT, CALL LBC. _____
- 5 Confirm top of the oven is open to fresh air (makeup air). IF NOT, CALL LBC. _____
- 6 Confirm gas supply type to oven (ask GC or others if not labeled!!!) Nat _____ Propane _____
- 7 Oven gas type per data plate (must be the same as gas type supplied to oven- IF NOT, CALL LBC!!!) Nat _____ Propane _____
- 8 Record gas SUPPLY-SIDE pressure (inches WC) _____ (must be 5 - 14" WC - IF NOT, CALL LBC!!!)
- 9 Water Supply Treatment: RO _____ Filter Cartridge _____ Softener _____ (CALL LBC IF Softener!) None _____
 Other _____
- 10 Confirm supply voltages using meter:
 - Record high voltage (SB 200-250 for 208V connection; 440 - 490 for 480V connection)

L1 to L2	_____	VOLTS
L2 to L3	_____	VOLTS
L1 to L3	_____	VOLTS
	_____	VOLTS
 - Record 120 volt breaker to neutral (SB 100 - 130) _____

Installation Quality:

- 1 Confirm gap on the latch side of the door is even to within 1/8" top-to-bottom. If not, call LBC. _____
- 2 Confirm gap at the top of the door is even to within 1/8" left-to-right. If not, call LBC. _____
- 3 Confirm burner cover is installed. If not, install it. _____
- 4 Confirm snorkel between draft inducer and hood is installed. If not, install it. _____
- 5 Confirm chamber vent duct is in place and secured to hood. If not, install it. _____
- 6 Confirm flex line between gas supply pipe and gas valve is connected on both ends (SEE PHOTO). If not, connect it USING THE GASKET SUPPLIED WITH THE OVEN. _____
- 7 Confirm fasteners inside the oven (ceiling, floor clamp, hinges, etc.) and hood are tight. If not, tighten them. _____
- 8 Confirm filters above door are seated properly within the frame. If not, adjust until seated properly. _____
- 9 Confirm there are no leaks where the water supply is connected above the oven. _____

Check floor sweep:

- Confirm door sweep is lowered to the floor and seals when door is closed. If not, adjust. _____
- Confirm metal backing plate is 3/4" from the floor. If not, adjust. _____

Functional Checks:

- Turn OFF gas supply shutoff lever (behind control door)
- Turn oven ON

Test Hood Airflow:

- 1 Hold sheet of paper to filters above door, confirm paper is sucked tight to filters. If not, check that exhaust fan is connected to the oven and all breakers & switches are on. _____

Check Blower Motor Direction:

- 1 Close oven door and confirm blower motor is rotating counter clockwise (MUST BE

VIEWS FROM TOP OF OVEN). If motor is not rotating counter clockwise, then an electrician needs to reverse the power legs.

- 2 After blower rotation is CONFIRMED as COUNTER CLOCKWISE, relocate the wire connected to the blower direction air switch located just in front of the blower motor from the "Common" terminal to "Normally Closed" terminal.

Check Burner:

- Turn ON gas supply shutoff lever (behind control door)
- Turn oven control ON; Vent CLOSED; Blower ON

- 1 Set temperature to 200F. Confirm actual temp rises to 200F.
- 2 Measure and record supply side gas pressure when burner is lit (should be 5" - 14" WC)
- 3 Measure and record pressure FROM gas valve when burner is lit (i.e., manifold supply pressure). Confirm pressure remains CONSISTENT.

_____"WC
_____"WC as consistently observed

Combustion Test:

Set temp to 450F

- 1 **MEASURE CARBON MONOXIDE: Wait one minute AFTER OVEN LIGHTS and THEN insert tip of combustion analyzer (meter) wand into exhaust. Once CO per the meter stabilizes at the highest level, record this number (maximum 50 PPM - CALL LBC IF HIGHER!).**
NOTE: DO NOT PLACE COMBUSTION ANALYZER WAND INTO EXHAUST AT THE TIME THE OVEN LIGHTS, ALWAYS WAIT ONE MINUTE AFTER FLAME IGNITION BEFORE INSERTING THE WAND INTO THE EXHAUST!!

____ CO PPM (max 50 ppm)

- 2 Take photo of highest CO PPM measurement on meter and submit with this checklist.
- 3 Check flame sensor voltage at the ignition control (Fenwal) between the two blue female Faston connections next to the red light while the oven is firing. Confirm the voltage is a minimum of 2.5VDC and is consistent for a period of ten seconds (+/- 0.1VDC). SEE PHOTO. Record the voltage observed.

____ VDC as consistently measured

NOTE: If the voltage is less than 2.5VDC, inspect the sensor and confirm it is positioned below the burner, in the flame. Confirm wire connection between the sensor and ignition control (Fenwal) is secure. If voltage remains under 2.5VDC, recheck gas pressure per steps above. Call LBC if unable to achieve consistent 2.5+ VDC.

Steam Test:

1. Static Water Pressure: observe water gauge inside control door (bottom) and confirm pressure is a minimum of 40PSI when the oven is not calling for steam.
2. Dynamic Water Pressure: press and hold the "steam" button on the backup control located inside control door (top) for 30 seconds while watching the water pressure gauge. Confirm water pressure remains at a minimum of 25psi for the entire 30 second duration (other than a brief drop to zero when button is first pressed).

_____ Static PSI observed

_____ Dynamic PSI observed

Rack Stopping Position (perform test when oven is HOT):

1. Confirm carrier stops with rack centered in door for easy removal. If not, adjust.
2. Confirm all four set screws on carrier are tight. If not, tighten.
3. Confirm two chrome caps covering set screws are installed. If not, install.

Check Rack Carrier Height (perform test when oven is HOT):

Open door, insert oven rack onto carrier

1. Confirm top of C-channel on rack is 1/4" - 5/8" above the flange on the rack carrier. SEE PHOTO. If gap is not 1/4" - 5/8", adjust carrier height.

Close oven door, WAIT for rack to lift entirely and begin to spin. Turn oven OFF.

1. Open the oven door and WITHOUT SPINNING THE RACK, confirm gap between the bottom of each rack caster and the oven floor is a minimum of 1/2". If not, adjust lift limit switch to achieve 1/2" clearance under casters for the full 360 degree rack rotation.

Final Inspection:

- 1 Confirm covers are installed in control compartment and inside oven. If not, install
- 2 Confirm manual gas valve inside oven is on. If not, turn on.
- 3 Confirm breakers inside oven are on. If not, turn on.
- 4 Confirm water pressure remains at the static minimum of 40PSI. If not, contact LBC or GC.
- 5 Confirm drain line is connected to floor drain. If not, contact LBC or GC.

Record Control Parameters Settings:

With oven turned "OFF", press and hold the F/C button on the control for appx five seconds until control lights up. Toggle through the Control Parameter Settings using the up/down arrows next to the TIMER display. Record the value shown in the STEAM display for each parameter. SEE PHOTO.

Sb _____

St _____

id _____

IL _____

PL _____

FC _____

tP _____

T4 _____

t5 _____

t6 _____

t7 _____

t8 _____

t9 _____

P5 _____

Temp Offset _____

(Temp offset is the value in "SET POINT" display when F/C button held down for 5+ seconds.)

Print Technician Name & Co: _____

Technician Signature: _____

Date Startup Completed: _____

GAS FLEX LINE AS PROPERLY CONNECTED

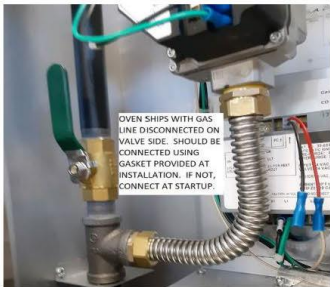

RACK CARRIER HEIGHT AS PROPERLY ADJUSTED



CHECK VDC BETWEEN TWO BLUE FEMALE CONNECTORS

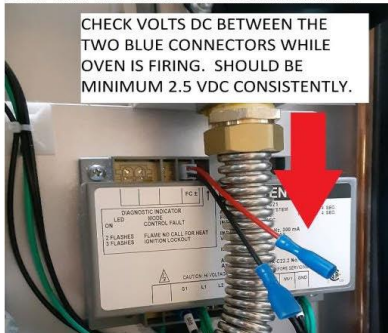

PRESS AND HOLD F/C TO ACCESS PARAMETERS



Air Shutter Settings LRO-1



Use the spacing tool to measure the shutter gap as shown.

Utilisez l'outil d'espacement pour mesurer l'écart d'obturation comme indiqué.

Use la herramienta de espaciado para medir el espacio del obturador como se muestra.



Use the angle tool to confirm shutter angle as shown.

Utilisez l'outil d'angle pour confirmer l'angle d'obturation comme indiqué.

Use la herramienta de ángulo para confirmar el ángulo del obturador como se muestra.

LRO-1G5 & E5	Rear / Arrière / Trasero		
	94 Deg		
	Inch	mm	Fraction
Top	0.50	13	1/2
2	0.21	5	7/32
3	0.21	5	7/32
4	0.18	5	3/16
5	0.21	5	7/32
6	0.25	6	1/4
7	0.25	6	1/4
8	0.25	6	1/4
9	0.29	7	9/32
10	0.38	10	3/8
11	0.35	9	11/32
Bottom	0.47	12	15/32

	Middle / Centre / Centro		
	90 Deg		
	Inch	mm	Fraction
	0.29	7	9/32
	0.21	5	7/32
	0.18	5	3/16
	0.18	5	3/16
	0.18	5	3/16
	0.21	5	7/32
	0.21	5	7/32
	0.25	6	1/4
	0.25	6	1/4
	0.25	6	1/4
	0.25	6	1/4
	0.25	6	1/4
	0.29	7	9/32
	0.32	8	5/16
	0.44	11	7/16

	Front / Avante / Anterior		
	90 Deg		
	Inch	mm	Fraction
	0.41	10	13/32
	0.25	6	1/4
	0.25	6	1/4
	0.29	7	9/32
	0.25	6	1/4
	0.25	6	1/4
	0.25	6	1/4
	0.25	6	1/4
	0.25	6	1/4
	0.25	6	1/4
	0.29	7	9/32
	0.38	10	3/8
	0.44	11	7/16

Air Shutter Settings LRO-2



Use the spacing tool to measure the shutter gap as shown.

Utilisez l'outil d'espacement pour mesurer l'écart d'obturation comme indiqué.

Use la herramienta de espaciado para medir el espacio del obturador como se muestra.



Use the angle tool to confirm shutter angle as shown.

Utilisez l'outil d'angle pour confirmer l'angle d'obturation comme indiqué.

Use la herramienta de ángulo para confirmar el ángulo del obturador como se muestra.

LRO-1G5 &E5	Rear / Arrière / Trasero		
	94 Deg		
	Inch	mm	Fraction
Top	0.38	10	3/8
2	0.38	10	3/8
3	0.50	13	1/2
4	0.47	12	15/32
5	0.47	12	15/32
6	0.47	12	15/32
7	0.47	12	15/32
8	0.5	13	1/2
9	0.47	12	15/32
10	0.59	15	19/32
11	0.66	17	21/32
Bottom	0.75	19	3/4

Middle / Centre / Centro		
90 Deg		
Inch	mm	Fraction
0.35	9	11/32
0.38	10	3/8
0.32	8	5/16
0.29	7	9/32
0.29	7	9/32
0.21	5	7/32
0.25	6	1/4
0.32	8	5/16
0.32	8	5/16
0.32	8	5/16
0.41	10	13/32
0.41	10	13/32

Front / Avante / Anterior		
90 Deg		
Inch	mm	Fraction
0.41	10	13/32
0.50	13	1/2
0.56	14	9/16
0.44	11	7/16
0.47	12	15/32
0.44	11	7/16
0.44	11	7/16
0.47	12	15/32
0.50	13	1/2
0.56	14	9/16
0.59	15	19/32
0.59	15	19/32

Illustrated Parts List / Liste illustrée des pièces / Ilustrado Lista de Piezas

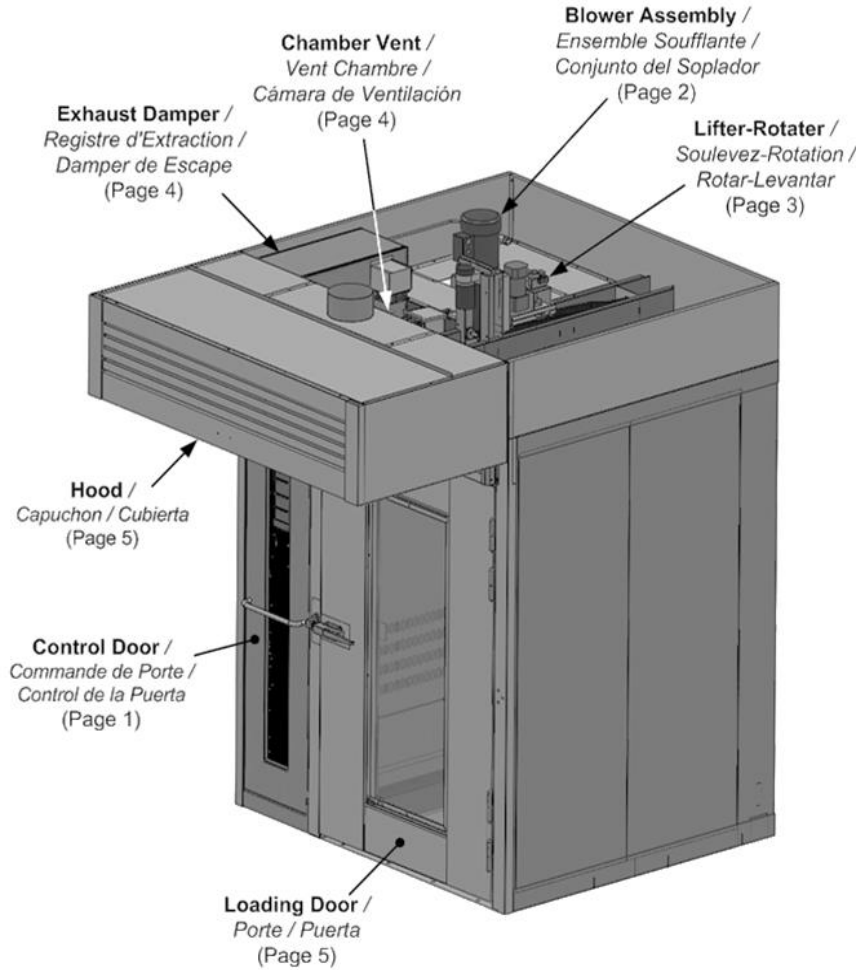

Not Shown/ Pas montré /
No mostrada

Water Assembly/
Assemblée de l'eau /
Asamblea de agua

Gas Inlet/ Entrée de gaz /
Entrada de Gas

Loading Door Hinges/
Charnières de porte de
chargement / Bisagras
para puertas de carga

Electrical Box/ Boîte
électrique / Caja electrica

Burner Assembly/ Brûleur
/ Asamblea del quemador

Heat Exchanger
Assembly/ Ensemble
d'échangeur de chaleur /
Asamblea del
intercambiador de calor

Heating Element
Assembly/Heating

Element Assembly/ Heating Element Assembly

Overview / Aperçu / Visión de Conjunto

Door with Digital Control /

Porte avec contrôle numérique / Puerta con control digital

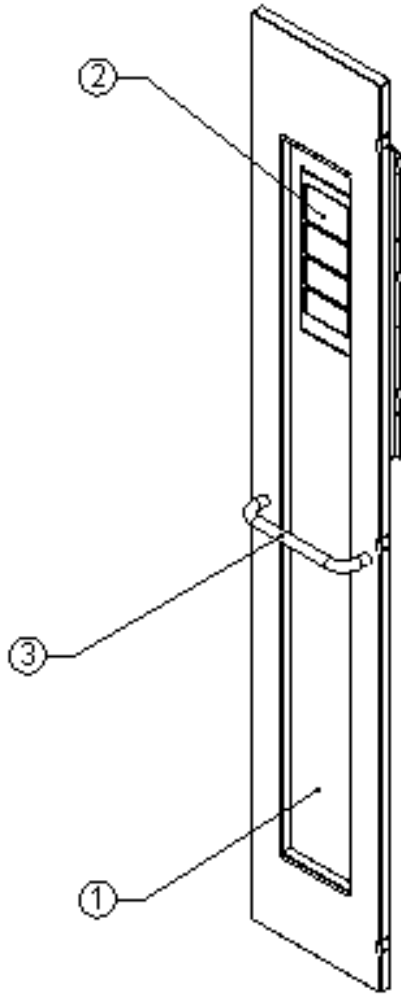

Item	Parts		Description
	LRO-1__	LRO-2__	
1	60301-101	60301-151-D	Overlay (-70)
2	40102-70	40102-70	Control
3	70301-03	70301-04	Handle

Touch Screen Control with Android™ /
Contrôle d'écran tactile avec Android™ /
Control de pantalla táctil con Android™

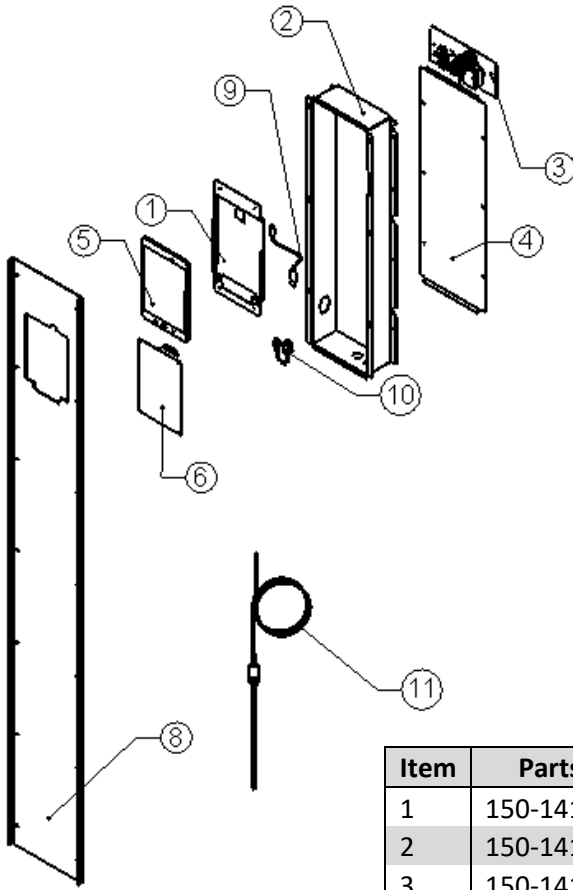

Item	Parts - LRO	Description
1	150-1415	Mounting Bracket
2	150-1416	Control Surround
3	150-1417	Back-up Control Assembly
4	150-225-4	Rear Cover
5	40102-100-3	Control Tablet
6	40102-100-1	I/O Board
N/S	41100-33	RTD Temp Sensor
8	150-1418-100-1	Door Panel Overlay, Gasket
9	40102-100-5	12" Micro USB, Cable
10	40102-100-4	IOIO Board Cable
11	41100-42a	K-Type Thermocouple

Android is a trade mark of Google Inc.

-70 Digital Control /
 contrôle numérique /
 control digital

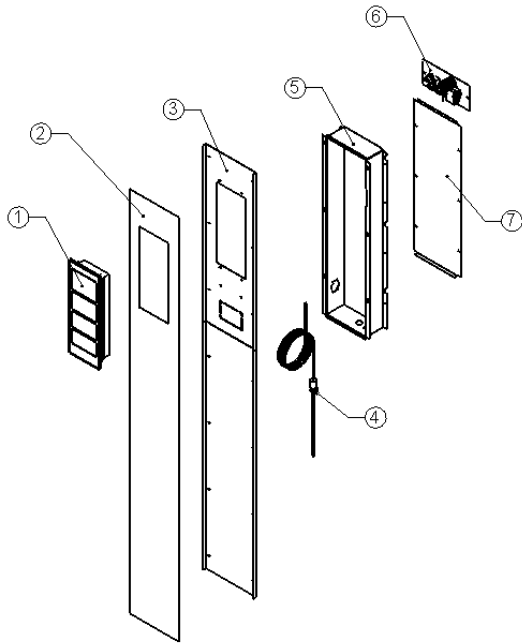

Item	Parts - LRO	Description
1	40102-70	Circuit Board, Digital
2	60301-101	Overlay LRO -70
3	150-1221	Panel, Control Mount
4	41100-42	Thermocouple, LRO/LMO/Pizza
5	150-1416	Surround, Control
6	150-1417	Assy, Back Up Control
7	150-225-4	Control, Rear Cover

-54 Digital Control /
 Contrôle numérique /
 Control digital

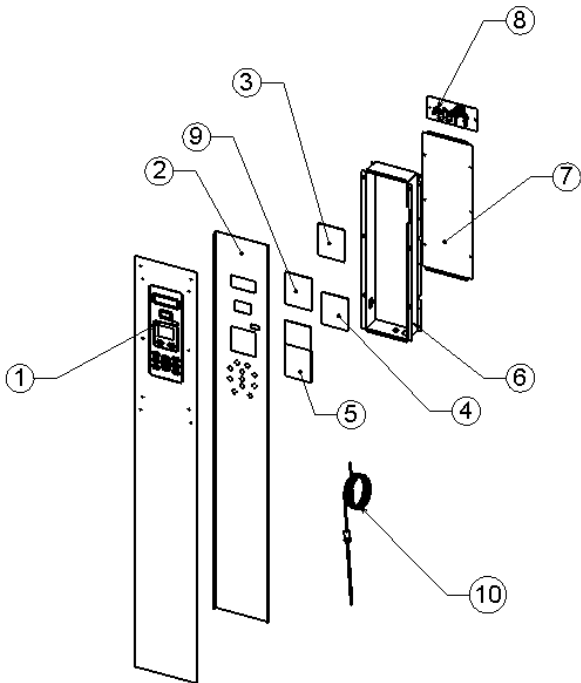

Item	Parts - LRO	Description
1	60601-151-L	Label, LRO, -54
2	150-1276	Panel, Control Mount
3	40102-54-3	Circuit Board, CPU
4	40102-54-4	Circuit Board, Relay
5	40102-54-5	Circuit Board, Touch Pad
6	150-1416	Surround, Control
7	150-225-4	Control, Rear Cover
8	150-1417	Assy, Back Up Control
9	40102-54-1	LED Board
10	41100-42a	K-Type Thermocouple

Blower Assembly /
Ensemble Soufflante /
Conjunto del Soplador

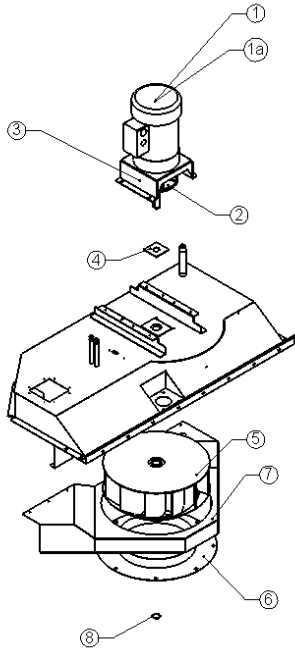

Item	Parts		Description
	LRO-1__	LRO-2__	
1	30200-59	30200-59	Motor, 3-Phase
1a	30200-59-1	30200-59-1	Motor, 1-Phase
2	71500-14	71500-14	Heat Slinger
3	150-367	150-367	Motor Mount
4	150-368	150-368	Shaft Seal, Bushing
5	71500-13	71500-15	Blower Wheel
6	71500-03	71500-05a	Inlet Ring
7	150-1381	160-1319-1	Blower Shelf
8	20601-07	20601-07	Snap Ring

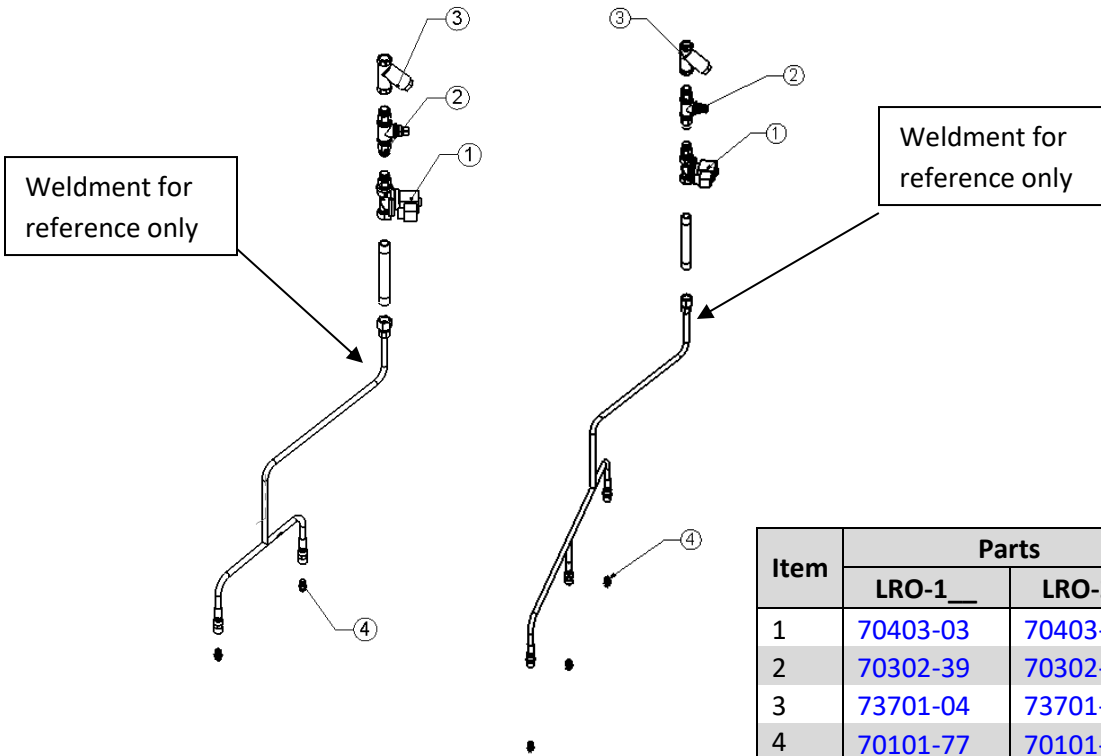

Item	Parts		Description
	LRO-1__	LRO-2__	
1	70403-03	70403-03	Solenoid Valve
2	70302-39	70302-39	1/2 Close Nipple
3	73701-04	73701-04	Strainer
4	70101-77	70101-77	Spray Nozzle

Water Supply /
approvisionnement en eau /
suministro de agua

Item	Parts		Description
	LRO-1__	LRO-2__	
1	150-138	150-138	Clip, Teflon
2	150-137	150-137	Clip, SS
3	30301-02	30301-02	Microswitch
4	30308-05	30308-05	Air Switch
5	70104-01	70104-01	Hose
6	71700-03	71700-03	Hose Clamp
7	50803-004	50803-004	Lifter Pin
8	150-130-1	150-130-1	Bracket
9	150-179-2	150-179-2	Switch Bracket
10	150-720	160-720	Lift Rotation Base
11	150-719-2	150-719-2	Fork Assembly
12	30200-68-A	30200-68-A	Actuator Kit
13	73500-04	73500-04	Collar ½ ID

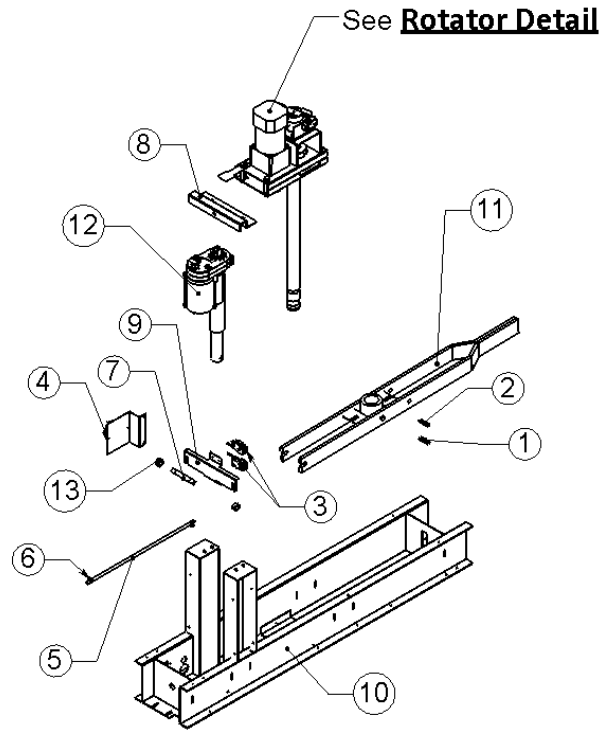

**Lifter-Rotater /
Soulevez-Rotation ,
Rotar-Levantar**

Item	Parts - LRO	Description
1	73000-06a	Driven Gear
N/S	40704-12	Capacitor, 12µf
2	73000-05C	Sprocket
3	30200-56-1	Drive Motor
8	150-718-201	Rotator Top
4	70200-11	Flange Bushing
5	70200-12	Washer
6	150-718-202	Rotator Bottom
7	150-150-2	Spacer
9	50803-002	Drive Collar
10	70200-13	Bearing, Gear
11	70200-14	Friction Disk
12	20601-04	Snap Ring
13	50803-001-99	Rotation Shaft
14	150-160	Teflon Spacer
15	150-161	Microswitch Brkt
16	30301-15	Microswitch
17	150-158b	Spring Tab
18	150-159-1a	Pointer Assy
*	70200-15	Bushing, Split

**Rotator Detail /
Rotateurs Détail /
Detalle de los
Rotadores**

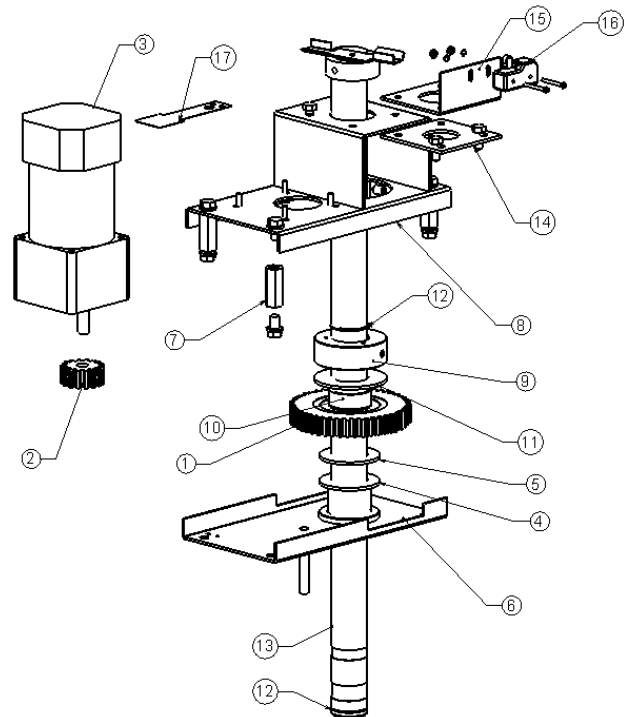

Florescent Light /
 Lumière fluoescence /
 Luz fluoescence

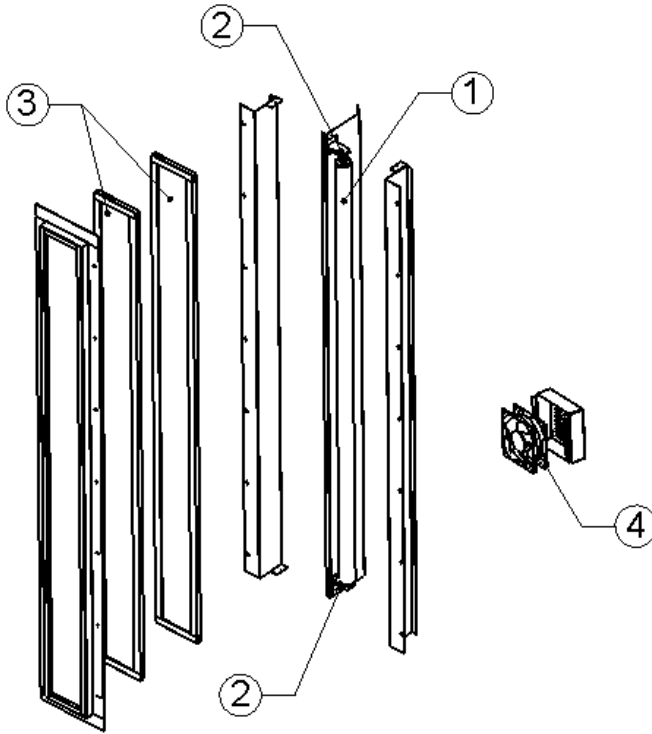

Item	Parts - LRO	Description
1	31600-13	Bulb, 4' Florescent
2	31602-07-A	Florescent Lamp Fixture
3	71301-20	Window, Light Rack Oven
4	150-1397	Fan Assembly

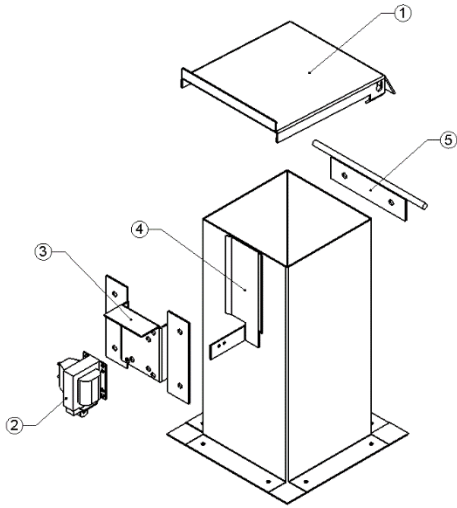

Item	Parts - LRO	Description
1	150-1226	Lid, Vent
2	70403-04-1	Solenoid Act.
3	150-1259	Solenoid Mount
4	150-1260	Vent Shuttle
5	150-1275	Hinge, Lid

Chamber Vent /
Vent Chambre /
Cámara de
Ventilación

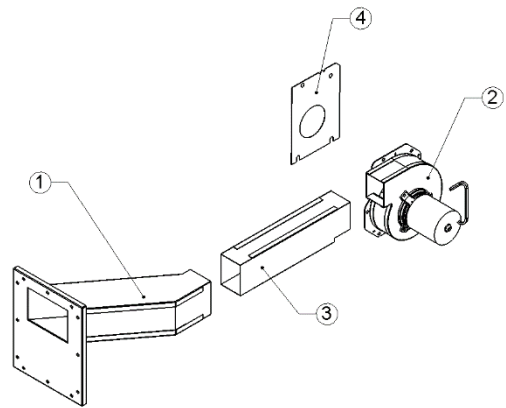

Item	Parts		Description
	LRO-1__	LRO-2__	
1	160-1355	160-1355	Exhaust Duct
2	30200-87	30200-87	Draft Blower
3	150-1356	160-1356	Duct Extender
4	150-1376-1	160-1376-1	Exhaust Restrictor

Exhaust Duct /
Conduit d'échappement /
Ducto de escape

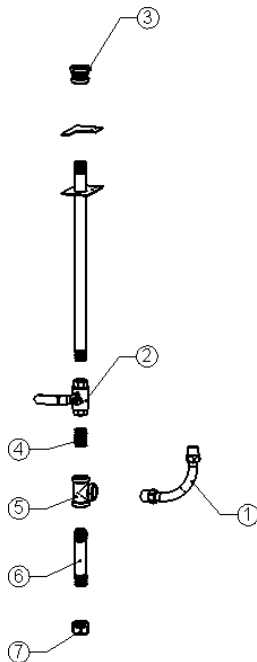

Item	Parts - LRO	Description
1	70101-103	Flexible Gas Line
2	70402-09	Manual Gas Valve
3	70200-32-11	Bell Reducer
4	70200-32-9	3/4 NPT Nipple, Close
5	70200-32-2	3/4 NPT Tee
6	70200-32-8	3/4 x 4in NPT Pipe
7	70200-32-3	3/4 NPT Pipe Cap

Gas Inlet /
Entrée du Gaz /
Entrada de Gas

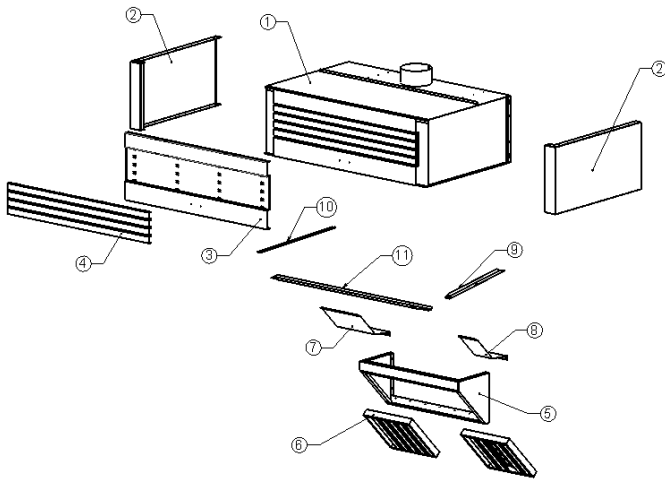

Hood / Capuchon / Cubierta
Standard Hood

Item	Parts		Description
	LRO-1__	LRO-2__	
1	150-780C	160-780C	Hood Assembly
2	150-1222	150-1222	Hood End Cover
3	150-1457	160-1221	Hood Face
4	150-1206-5	160-1206-5	Louver Hood
5	160-1218b	160-1218b	Filter Box Assembly
6	72606-11	72606-11	Grease Filter
7	150-1451-1	160-1451-1	Body Vent Cover
8	150-1451-2	160-1451-1	Body Vent Cover
9	160-1447-4	160-1447-4	Drip Catch L/S
10	160-1447-3	160-1447-3	Drip Catch R/S
11	150-1447-1	160-1447-2	Drip Catch Front
*	150-1487	150-1487	Grease Cup

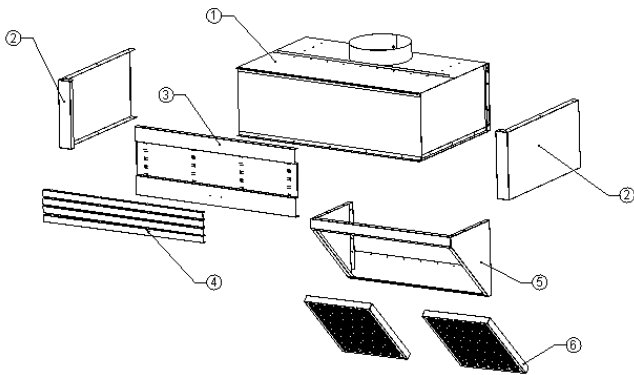

Hood-U / Capuchon-U / Cubierta-U
UL Listed Version

Item	Parts		Description
	LRO-1__	LRO-2__	
1	150-780U	160-780U	Hood
2	150-1222U	150-1222U	Hood End Cover
3	150-1221U	160-1221U	Hood Face
4	150-1206-5	160-1206-5	Louver, Hood
5	160-1218U	160-1217U-1	Filter Box Assembly
6	72602-20	72602-20	Grease Filter
*	160-1485	160-1485	Grease Cup

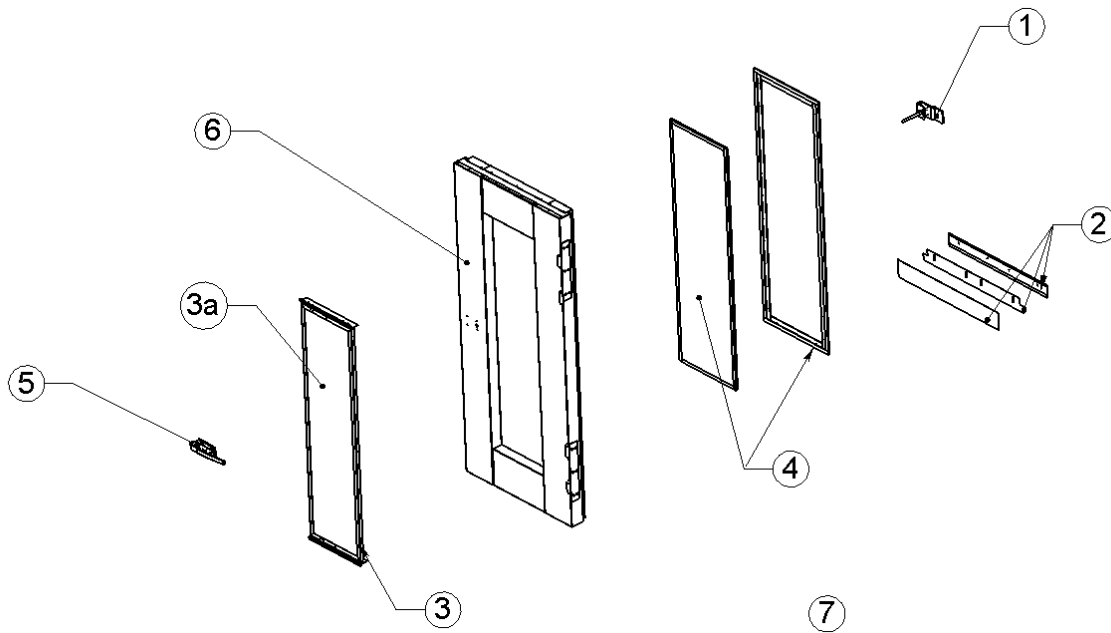

Loading Door /
Porte de chargement /
Puerta de carga

Item	Parts		Description
	LRO-1__	LRO-2__	
1	150-1323	150-1323	Escape Handle
2	72609-18	72609-181	Floor Sweep Assembly
3	160-1312	160-705B-30	Front Window Assembly
3a	71301-29	71301-25	Glass for item 3
4	71301-26	71301-24C	Glass, Main Door
5	50800-103	50800-103	Latch
6	150-1307E	160-705E-16	Door Weldment Assembly
7	150-705E6	160-705E6	Complete Door Assy
*	72609-18	72609-181	Door Sweep

Door Hinges /
Chargement Charnières /
Cargando Bisagras

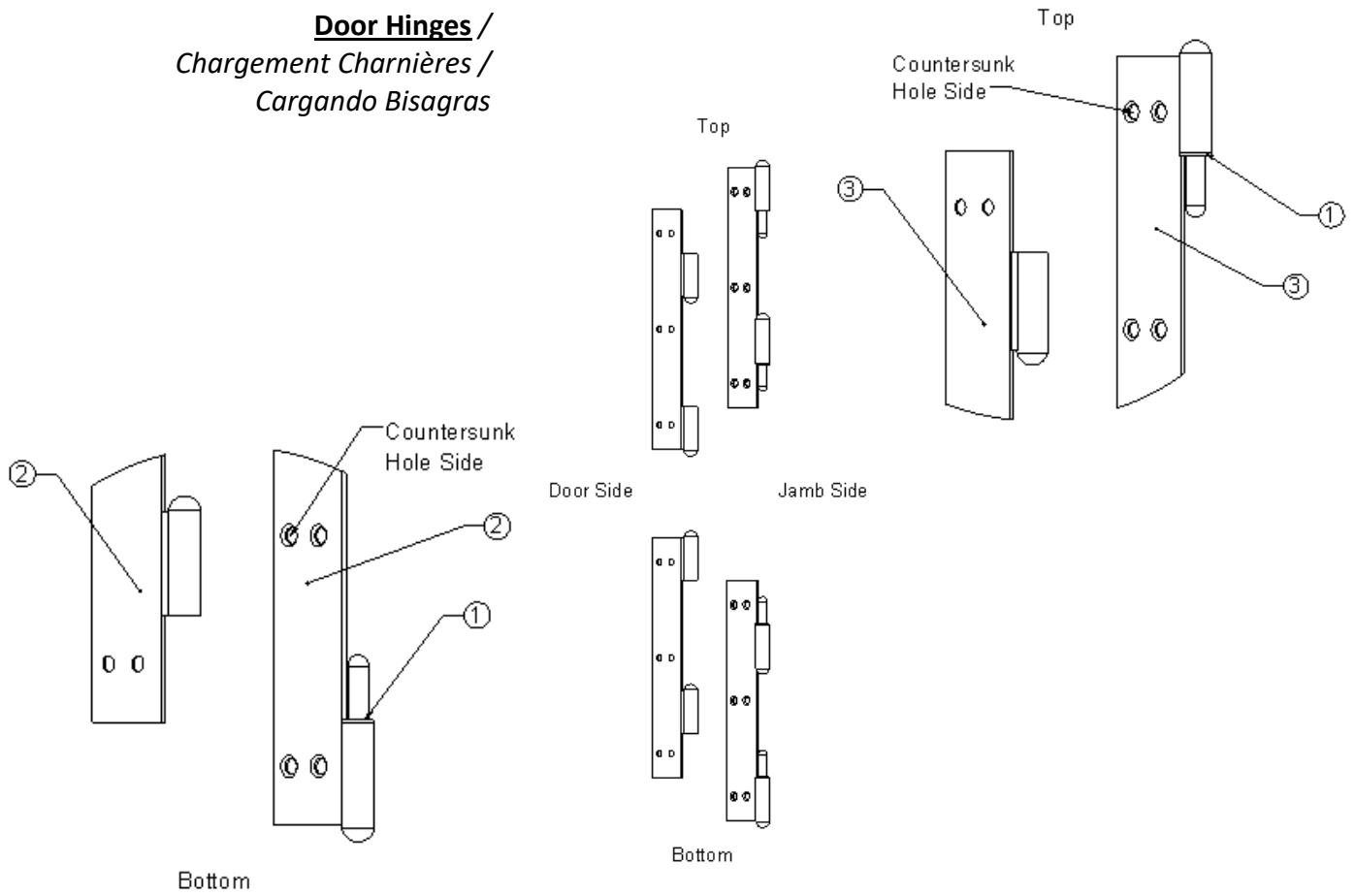

All LRO Ovens		
Item	Parts	Description
1	70601-25-3	Washer, Spacer
2	150-786	Female Hinge Bottom
	150-787	Male Hinge Bottom
3	150-786-1	Female Hinge, Top
	150-787-1	Male Hinge, Top
-	Screws	M6 x 8 Flat Head SS Internal Hex Drive

Electrical Box /
Compartiment Électrique /
Compartimiento Eeléctrical

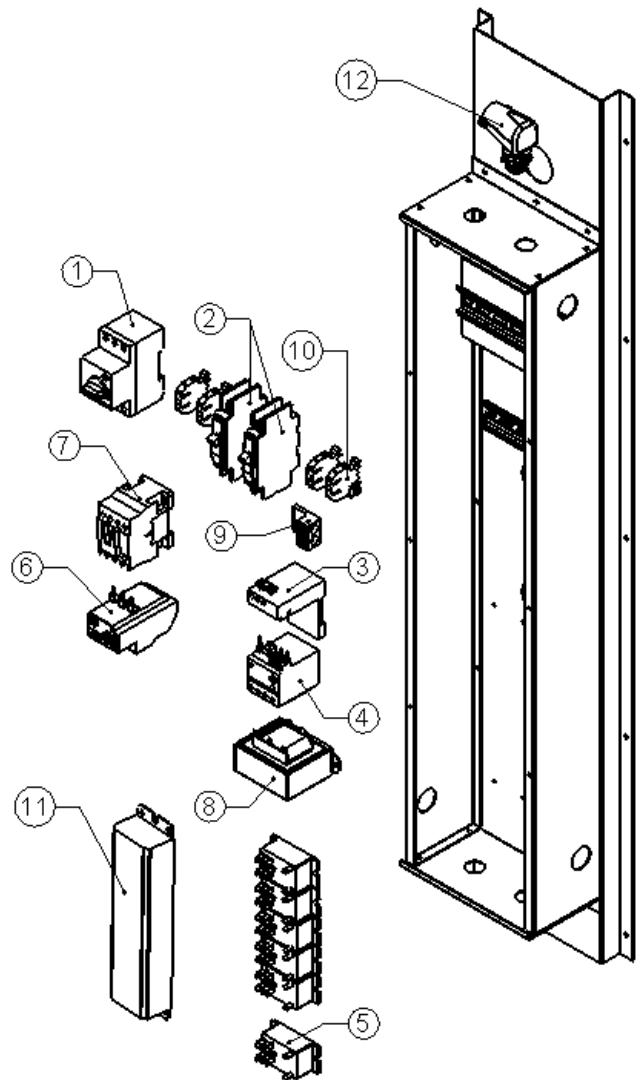

All LRO Ovens		
Item	Parts	Description
1	31800-12	15A Circuit Breaker, 3 Pole
2	31800-13-1	15A Circuit Breaker
3	73601-04	Mount for item 4
4	30707-06	Over-limit
5	30701-05	Relay
6	30707-03	Overload Relay (208-240 blower Motor)
6a	30707-02	Overload Relay (480V Blower Motor)
6b	30707-05	Overload Relay (1-ph Blower Motor)
7	30700-15	Contactor (Blower Motor)
8	31400-32	Transformer
9	31200-08	Ground Lug
10	31500-13	Terminal Block, 1 Pole
11	31600-12	Light Ballast
12	70505-05	90 Deg. Flex Conduit Connector

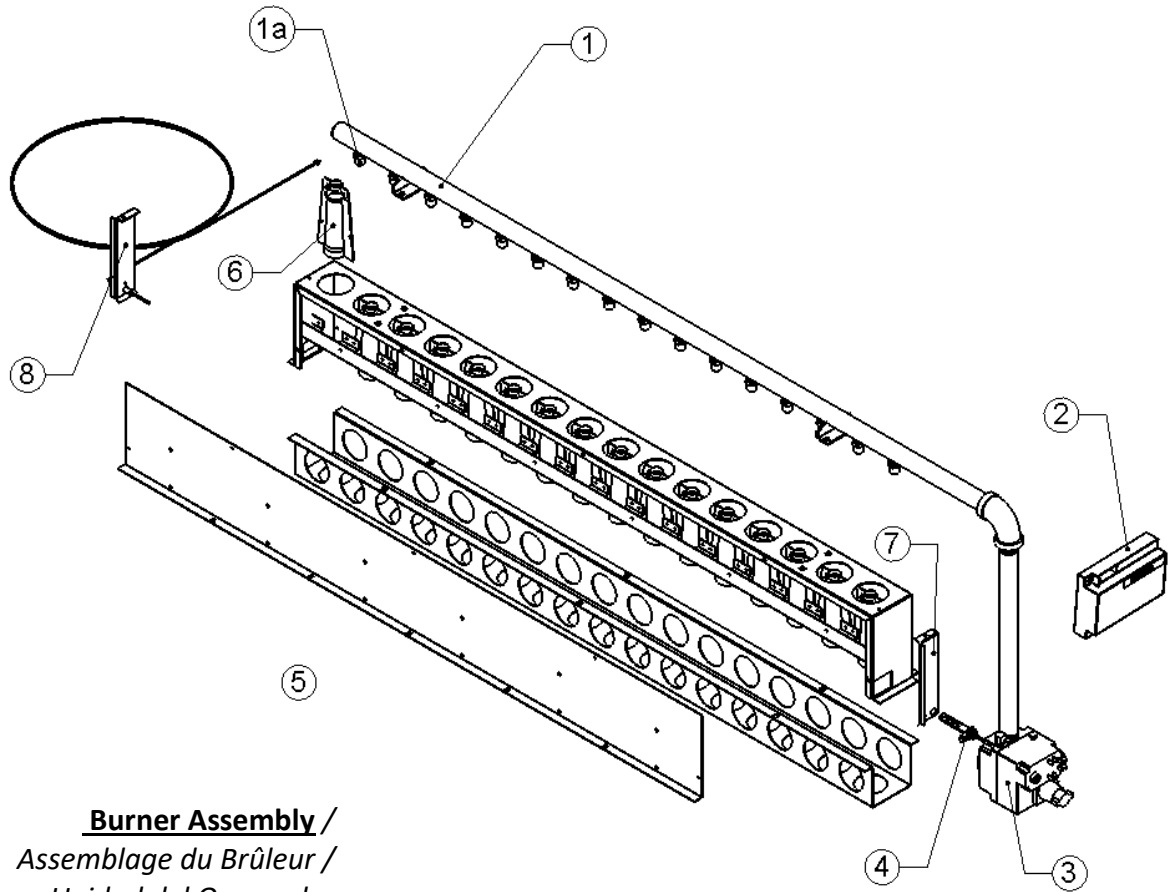

Burner Assembly /
Assemblage du Brûleur /
Unidad del Quemador

Item	Parts		Description
	LRO-1G__	LRO-2G__	
1	150-1334	160-1334	Manifold with Orifices
1a	80400-45 80400-52	80400-45 80400-55	Gas Orifices *
2	80300-18	80300-18	Gas Module
3	80505-14	80505-14	Gas Valve
4	80302-12	80302-12	Hot Surface Ignitor
5	150-1332	160-1332	Complete Burner
6	80002-14	80002-14	In-shot Burner
7	160-1335-1	160-1335-1	Ignitor Bracket
8	150-1488	150-1488	Flame Sensor Assy

*See Page 7: Specifications (Gas Ovens)

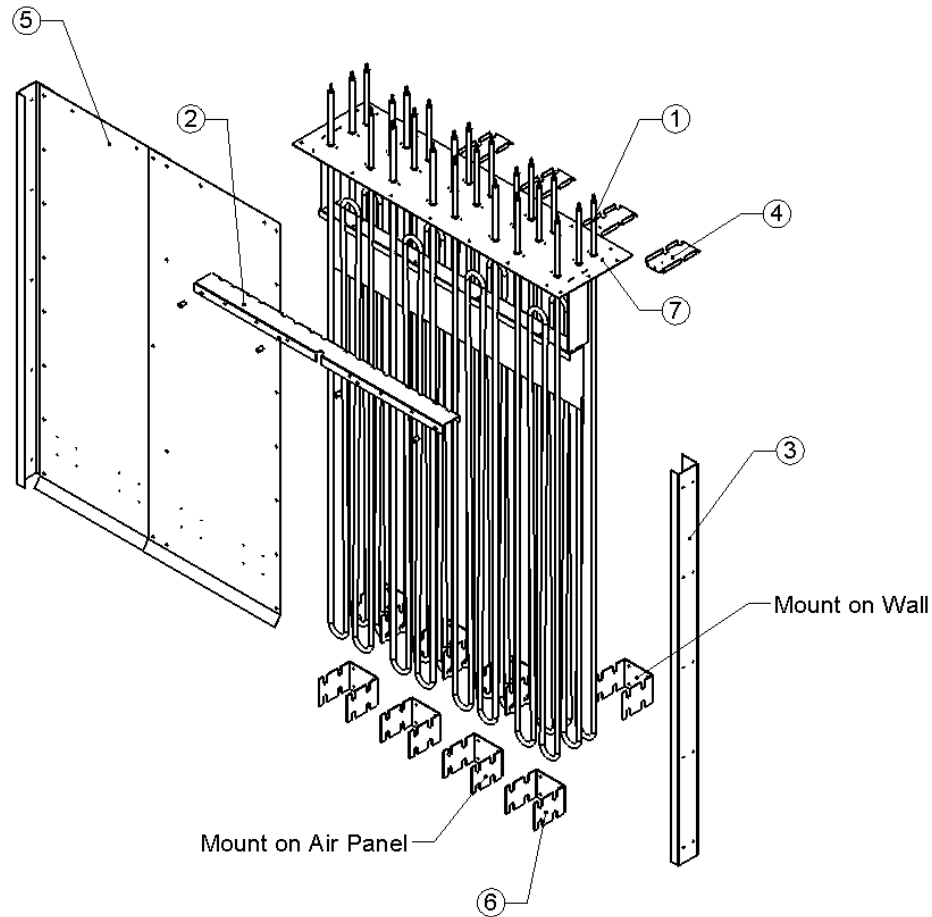

Element Assembly /
Assemblage d'élément chauffant /
Conjunto de elementos de calefacción

Item	Parts		Description
	LRO-1E_	LRO-2E	
1	11091-07	11091-07	Heating Element, 240 Volt, 4333 W
2	150-1331-26	160-1331-26	Clamp, Heating Element
3	150-1331-28	160-1331-28	Side Channel, Air Panel
4	150-1331-27	160-1331-27	Element Support
5	150-1331-29	160-1331-29	Air Panel
6	160-1331-30	160-1331-30	Element Support
7	150-1329-20A	160-1329-20A	Weldment, Heat Exchanger Assembly

Electric Oven Components /
Composants de four électrique /
Componentes eléctricos del horno

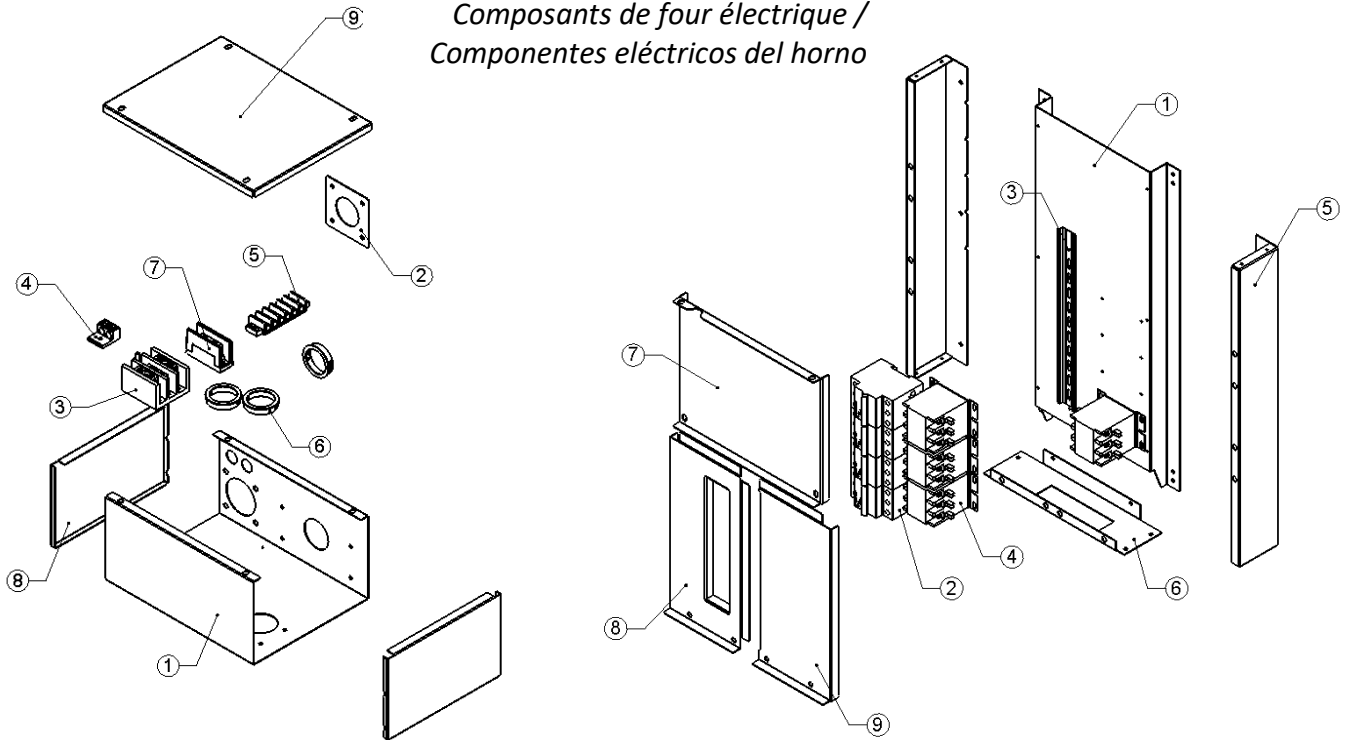

Item	Parts		Description
	LRO-1E_	LRO-2E	
Connector Box			
1	150-1454-1	150-1454-1	Body, Connection Box
2	160-1454-2	160-1454-2	Conduit Adaptor Plate
3	30500-07	30500-07-1	Terminal Block
4	31200-08	31200-08	Ground Lug, two position
5	30500-03	30500-03	Terminal Strip, 6 Position
6	70801-08	70801-08	Plastic Bushing
7	30500-11-1	30500-11-1	Terminal Block
8	150-1454-3	150-1454-3	End, Connector Box
9	150-1454-4	150-1454-4	Lid, Connector Box
Breaker Box			
1	150-1452-1	160-1452-1	Back Panel, Breaker/Contactor Bx
2	31800-10	31800-10	Breaker, 3 Pole
3	50800-109	50800-109	Din Rail
4	30700-17	30700-17	Contactor, 3 Pole
5	160-1452-2	160-1452-2	Side, Box
6	150-1452-3	160-1452-3	Bottom, Box
7	150-1452-4	160-1452-4	Cover, Breaker/Contactor Bx

Schematics

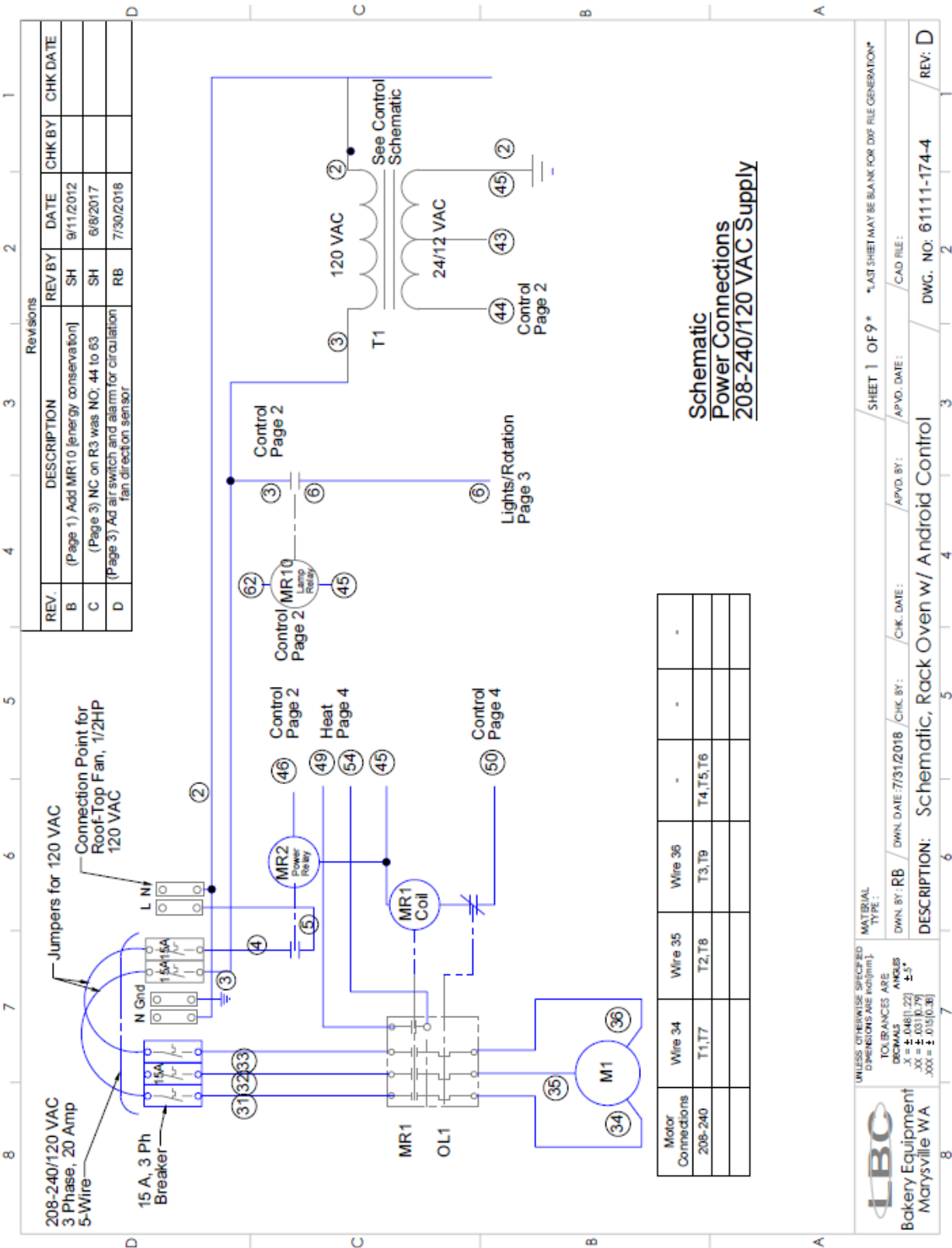

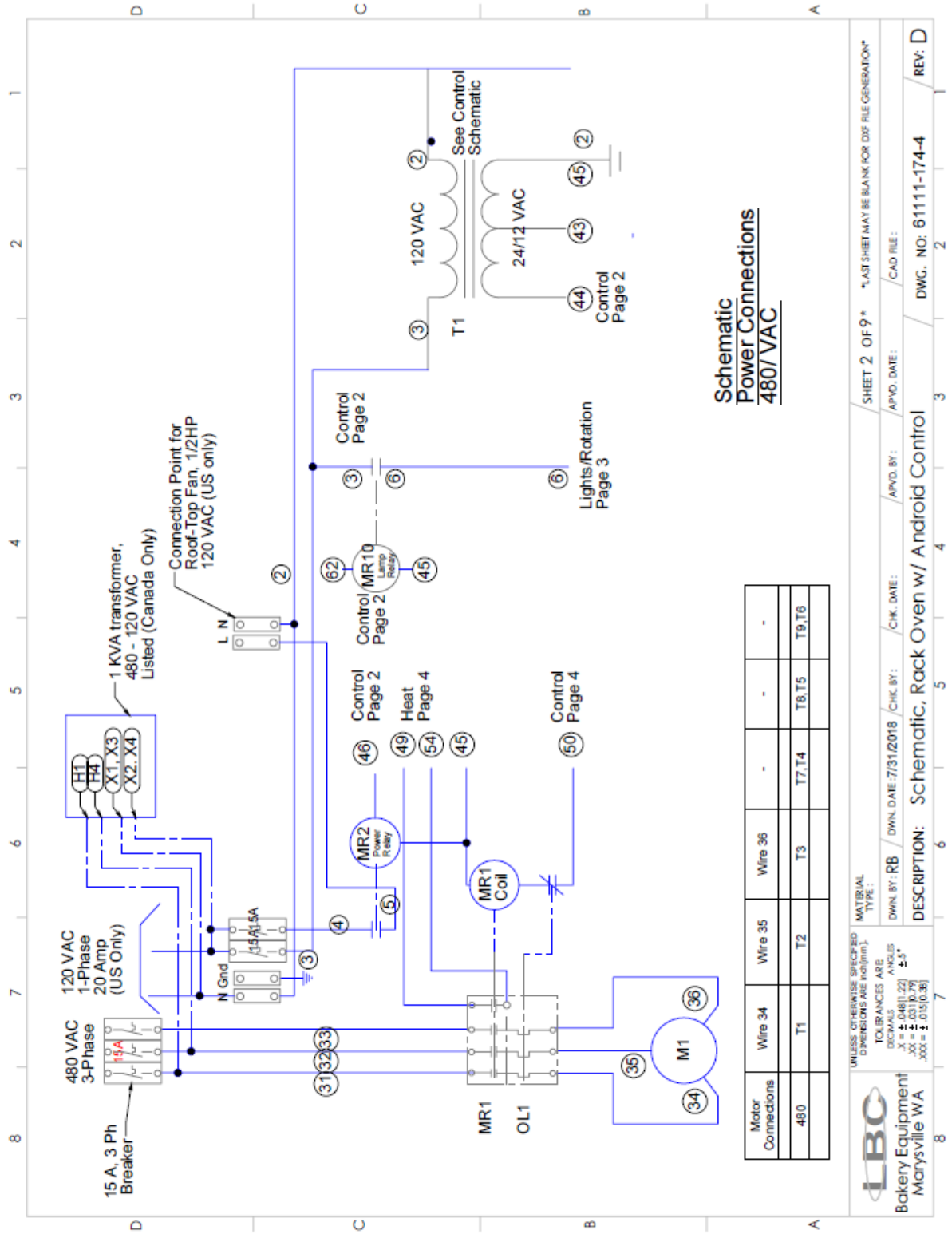

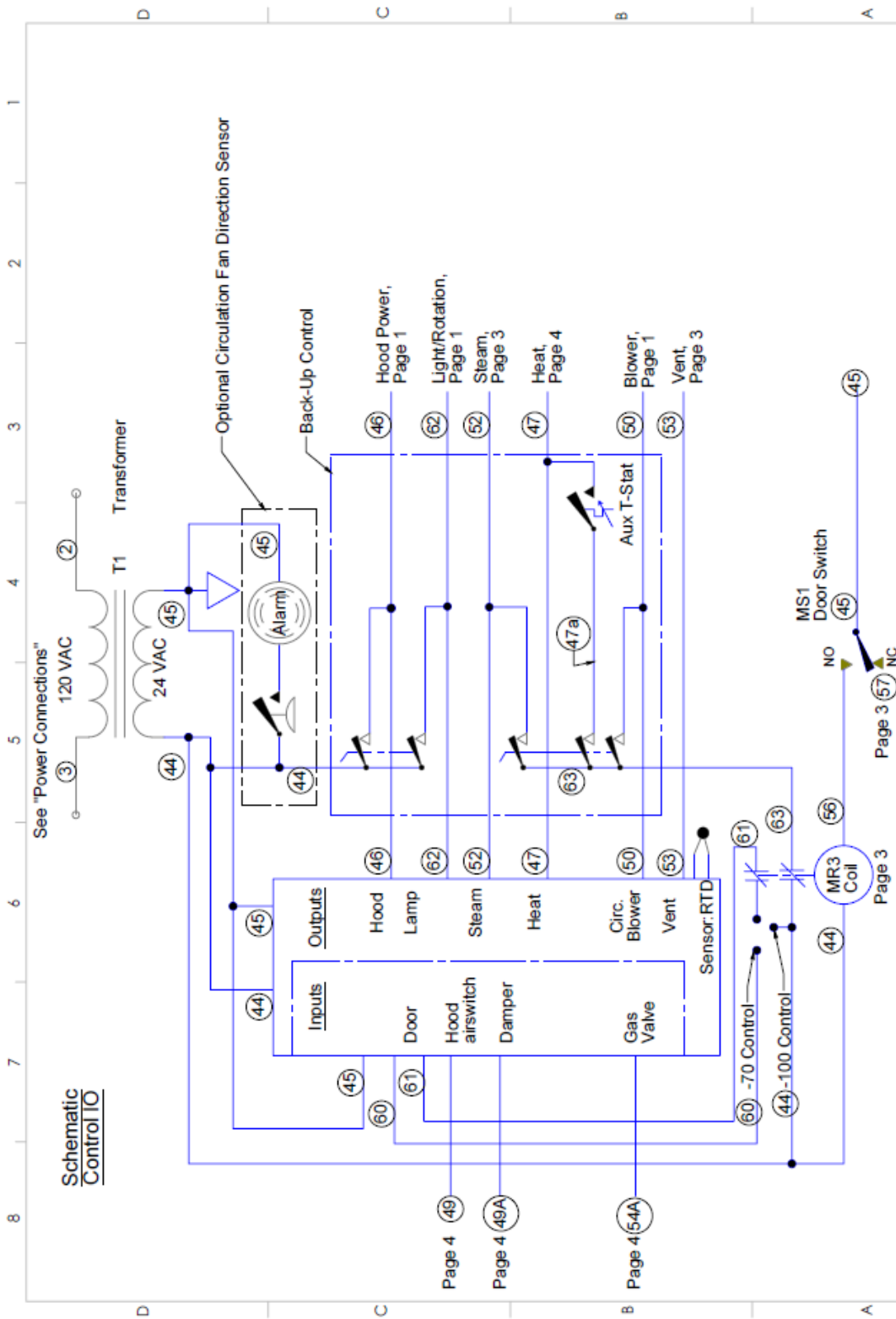

Schematic Control IO

See "Power Connections" 120 VAC 24 VAC Transformer

UNLESS OTHERWISE SPECIFIED DIMENSIONS ARE IN (mm). TOLERANCES ARE DECIMALS ANGLES		SHEET 3 OF 9*		*LAST SHEET MAY BE BLANK FOR DXF FILE GENERATION*	
DWN BY: RB	DWN DATE: 7/31/2018	CHK BY:	CHK DATE:	APVD BY:	APVD DATE:
DESCRIPTION: Schematic, Rock Oven w/ Android Control			DWG. NO: 61111-174-4		
MATERIAL TYPE:			REV: D		

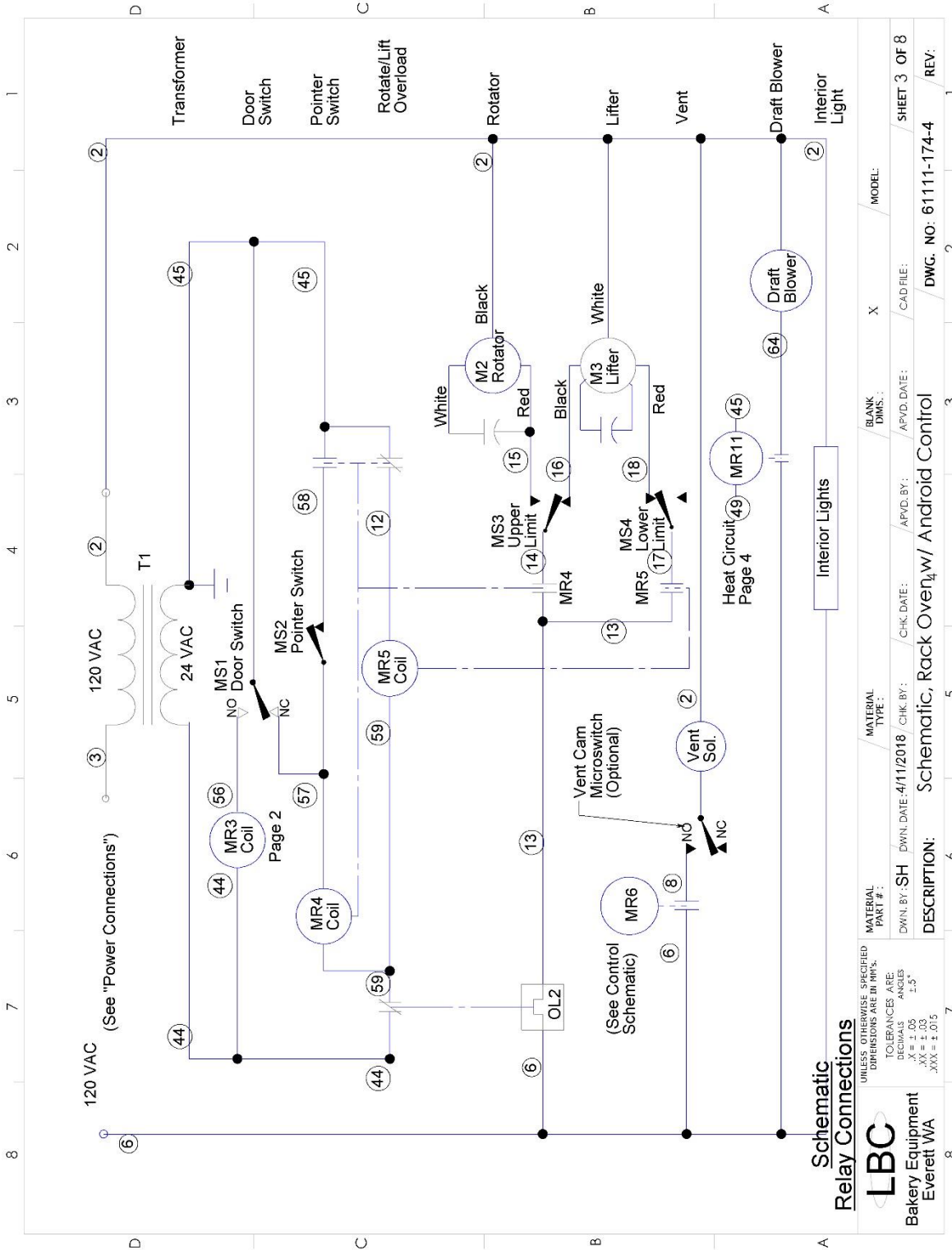

Schematic Relay Connections

UNLESS OTHERWISE SPECIFIED DIMENSIONS ARE IN INCHES. TOLERANCES ARE: DECIMALS ANGLES XX = ± .00 1.5° .XXX = ± .005

LBC
Bakery Equipment
Everett WA

MATERIAL PART # :
DWN. BY : SH DWN. DATE : 4/11/2018 CHK. BY :
CHK. DATE :
DESCRIPTION : Schematic, Rack Oven w/ Android Control

MATERIAL TYPE :
BLANK DIMS. : X
MODEL :
Page 4
Heat Circuit 49
MR11 45
Draft Blower 64
Interior Lights
Interior Light

SHEET 3 OF 8
DWG. NO: 61111-174-4
REV:

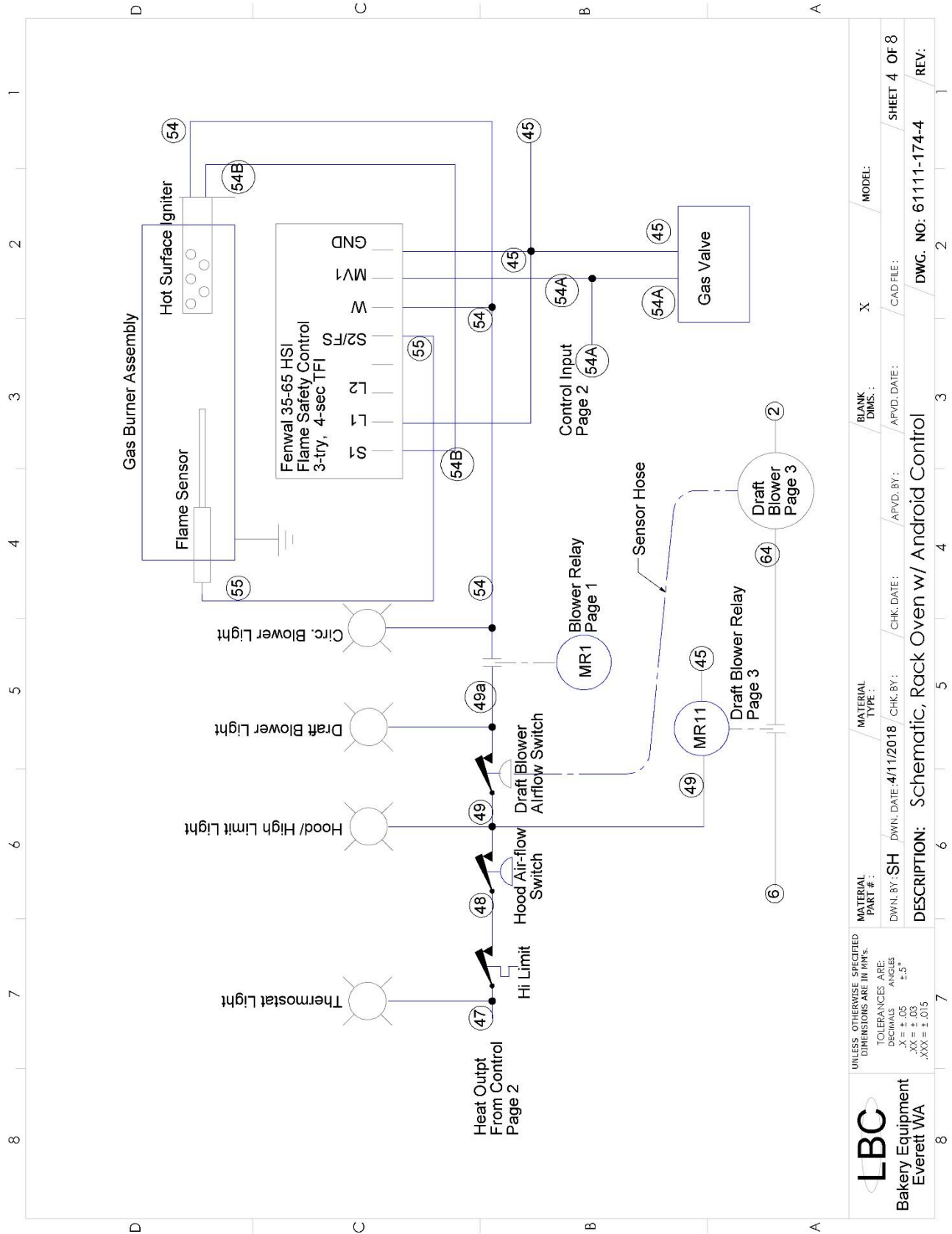

LBC Bakery Equipment Everett WA	UNLESS OTHERWISE SPECIFIED DIMENSIONS ARE IN INCHES. TOLERANCES ARE: DECIMALS .005 FRACTIONS 1/16 ANGLES ±.5° XX ±.005 XXX ±.015	MATERIAL PART # : DWN. BY: SH DWN. DATE: 4/11/2018 CHK. BY:	MATERIAL TYPE : DWN. DATE: 4/11/2018 CHK. DATE:	BLANK DIMS. : APVD. BY:	MODEL: CAD FILE:	SHEET 4 OF 8 DWG. NO: 61111-174-4 REV:
	DESCRIPTION: Schematic, Rack Oven w/ Android Control					

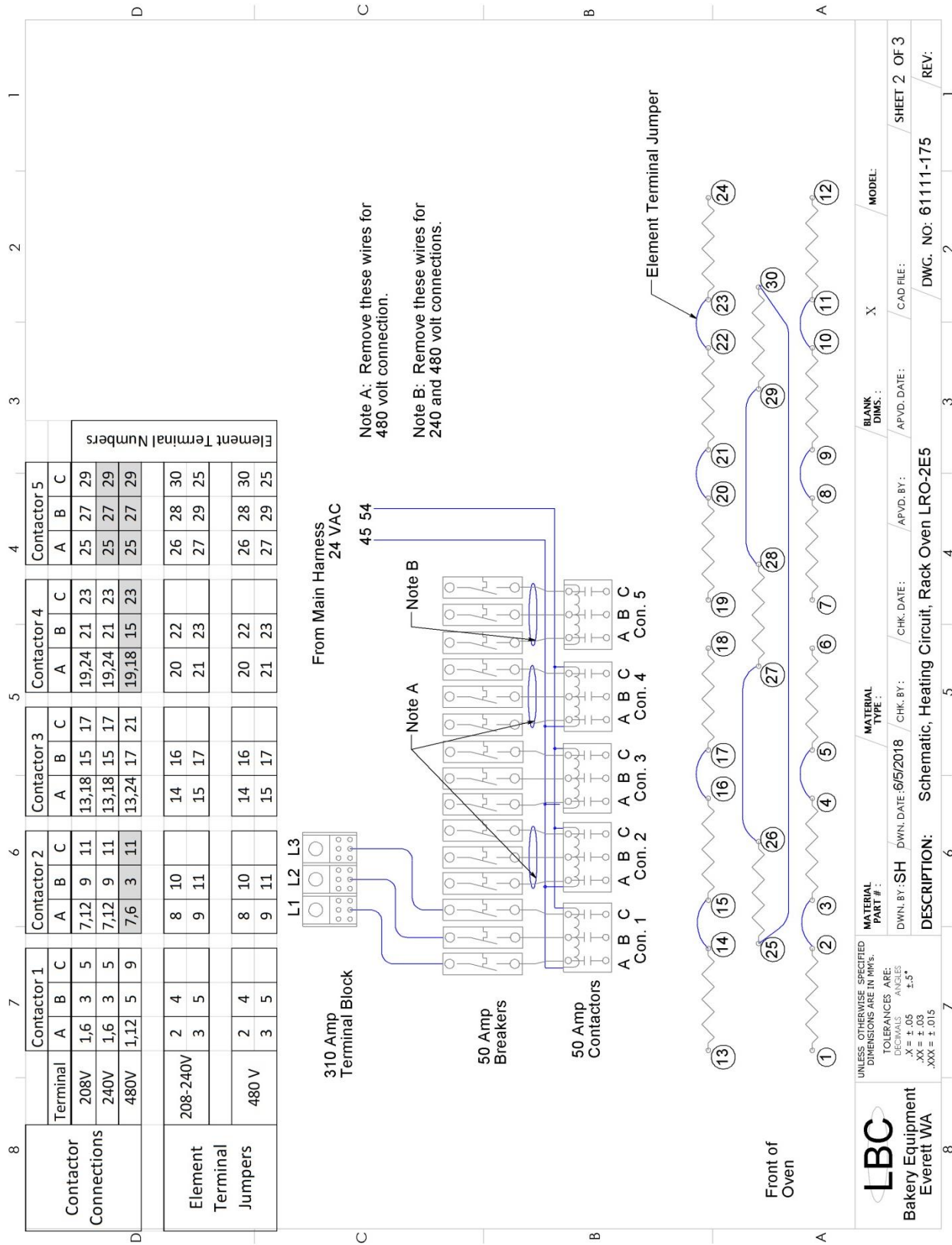

8	7			6			5			4			3			2			1			
	Terminal	A	B	C	A	B	C	A	B	C	A	B	C	A	B	C	A	B	C	A	B	C
Contactor Connections	208V	1,6	3	5	7,12	9	11	13,18	15	17	19,24	21	23									
	240V	1,6	3	5	7,12	9	11	13,18	15	17	19,24	21	23									
	480V	1,12	5	9	7,6	3	11	13	18,19	24	17	15	23									
Element Terminal Jumpers	All	2	4		8	10		14	16		20	22										
	Voltages	3	5		9	11		15	17		21	23										

Tape off wire 21

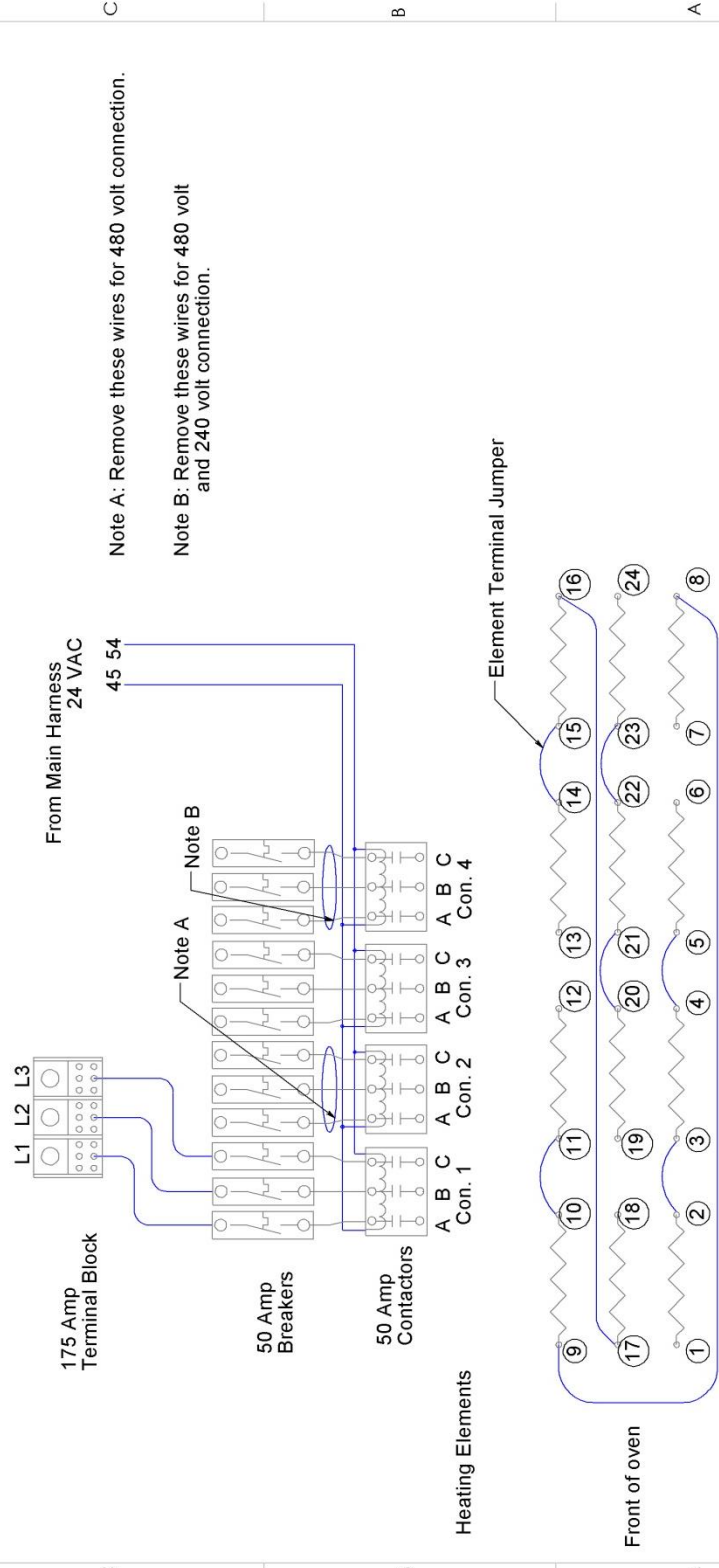

LBC Bakery Equipment Everett WA	UNLESS OTHERWISE SPECIFIED DIMENSIONS ARE IN INCHES. TOLERANCES ARE: FRACTIONS DECIMALS .XXX ± .015 .005 .XX ± .03 .01 .X ± .05 .02 X ± .08 .03	MATERIAL PART # : DWN. BY : SH CHK. BY : DWN. DATE : 6/5/2018 CHK. DATE :	MATERIAL TYPE : APVD. BY : APVD. DATE :	BLANK DIMS. : X MODEL :	DWG. NO. : 61111-175 REV. :
	DESCRIPTION : Schematic, Heating Circuit, Rack Oven LRO-1E5		CAD FILE :		SHEET 3 OF 3

Limited Warranty

LBC Bakery Equipment ("LBC Equipment") has been skillfully manufactured, carefully inspected and packaged to meet rigid standards of excellence. LBC Bakery Equipment, Inc. (LBC) warrants products produced and sold by LBC and its duly authorized agents, against defects in materials and workmanship within the following limitations:

What is Provided:

- Limited replacement parts as specified below, including standard ground shipping from LBC or service parts center when required.
- Limited labor for repair as specified below, including authorized service agent's transportation, portal to portal, up to one hundred (100) miles round trip and two (2) hours travel time.
- LBC, or an authorized service representative, will repair at LBC's sole discretion, any new LBC equipment, according to the limits and exclusions listed in this limited warranty.

Coverage Period:

Extending from the date of shipment from LBC or its duly authorized dealer/distributor for the specified period.

- LBC Equipment (Rack Ovens, Proofers, Retarder/proofers, Retarders, Rotisseries, Deck Ovens, Conveyor Ovens) shall be warranted for a period of one (1) year, limited parts and labor.
- Replacement Parts purchased from LBC or Authorized supplier shall be warranted for a period of ninety (90) days after installation by an authorized LBC service agent.

Conditions:

- Covered equipment must have been properly installed and according to the requirements of the installation manual and all applicable local codes.
- An Equipment Start-Up must have been performed by an authorized LBC servicer and the completed start-up form returned to LBC.
- The equipment shall not have been abused, misused or neglected or used for purposes other than intended by LBC.
- Water connected to the appliance shall have been in compliance with the following requirements:
 - Cold water, 40 to 80 PSI (Hot water to Rotisseries)
 - pH between 7 and 7.5
 - Conductivity less than 1/500,000 Ω per inch
 - Total dissolved solids less than 100 ppm
 - Hardness from 6.3 to 8.8 grains per gallon
 - Maximum Salinity and Ion content:
 - Chlorides:* < 30 ppm
 - Sulfates:* < 40 ppm
 - Iron:* < 0.1 ppm
 - Copper:* < 0.05 ppm
 - Manganese:* < 0.05 ppm
- It is the responsibility of the purchaser to install and maintain the water supply to the appliance. Failure to provide satisfactory water quality to the appliance in accordance with the operating manual requirements can cause damage to internal components and will VOID the warranty.

Conditions (cont):

- All repair work is to be performed by an LBC authorized service agent.
- Equipment must be at the operating location of the original purchaser/user and shall not have been resold or reclaimed by another party.
- LBC equipment is for commercial use only. If sold as a component of another (OEM) manufacturer's equipment, or if used as a consumer product, such equipment is sold AS IS and without any warranty.
- Conditions of sale of the equipment shall have been met in full.
- The request for repair shall be made within the limited period of the warranty.

Failure to meet the above conditions will void this warranty

Exclusions:

This warranty does not cover the following:

- Routine general maintenance, or periodic adjustment
- Consumable items including but not limited to, light bulbs, glass, door gaskets, rack bumpers etc.
- Thermostat calibration after the first 30 days of use
- Air and gas burner adjustments
- Fuse replacement
- Cleaning and adjusting burners and pilot burners
- Rack oven shutter adjustments
- Repairs, adjustments and corrections in the refrigeration portion of retarder/proofers resulting from the improper installation
- Retightening of screws and fasteners
- Failures caused by erratic or inadequate electrical, water, ventilation or gas service
- Unauthorized repairs
- Premature rusting, corrosion, or mineral build up caused by incoming water
- Attached water treatment systems
- Expedited freight on replacement parts other than standard ground shipments
- Ordinary wear and tear
- Use of the equipment for purposes other than those intended including non-commercial use such as residential or domestic
- Appliances installed outside the contiguous U.S., including Alaska and Hawaii, and Canada
- Incidental costs, charges, loss of business and damages as incurred by the user or others as a result of the use or failure of the equipment
- Work and workmanship of the authorized service agent or others in the repair of the equipment
- Other failures that are beyond the reasonable scope of this warranty
- Damages caused during shipment are to be reported to the carrier, are not covered under this warranty, and are the sole responsibility of the purchaser/user
- Natural disaster

This warranty is exclusive and in lieu of all other warranties, expressed or implied, including expressed or implied warranties of merchantability or fitness for a particular purpose, each of which is hereby expressly disclaimed. The remedies described herein are exclusive and in no event shall LBC be liable for special, consequential or incidental damages for the breach or delay in the performance of this warranty.