

# **Models LRP and LRPR**

## **Roll-in Rack Proofer and Retarder-Proofer**

### **Operator's Manual**

#### **LBC Bakery Equipment, Inc.**

6026 31<sup>st</sup> Ave NE

Marysville, WA 98271, USA

Phone: 888-RACKOVN (888-722-5686)

Fax: 425-642-8310

Email: [service@lcbakery.com](mailto:service@lcbakery.com)

Website: [www.lcbakery.com](http://www.lcbakery.com)



## **Table of Contents**

Responsibilities .....	3
Safe Operating Rules.....	4
Warnings, Cautions, Dangers:.....	7
Safety Procedures: .....	8
Proofer Control Operation.....	9
Retarder/Proofer Control Operation .....	11
Other Operating Precautions and Hints.....	15
Replacement Parts List.....	17
Schematics, Wiring Diagrams.....	20
Proofer Control Set-up and configurations.....	25
Retarder/Proofer Control Set-up and configurations.....	28
Limited Warranty .....	32

THE INFORMATION IN THIS MANUAL IS CRUCIAL AND MUST BE RETAINED FOR FUTURE REFERENCE. READ, UNDERSTAND, AND FOLLOW THE INSTRUCTIONS AND WARNINGS CONTAINED IN THIS MANUAL. IT IS THE RESPONSIBILITY OF THE OWNER/OPERATOR OF THE PROOFER/RETARDER TO TRAIN, SUPERVISE AND AUTHORIZE ANY PERSON DESIGNATED AS AN OPERATOR OF THIS APPLIANCE. ALL OPERATORS MUST READ THIS MANUAL AND UNDERSTAND IT AT ALL TIMES.

**FOR YOUR SAFETY  
DO NOT STORE OR USE GASOLINE OR OTHER FLAMMABLE  
VAPORS AND LIQUIDS IN THE VICINITY OF THIS OR ANY OTHER  
APPLIANCE.**

**WARNING: IMPROPER INSTALLATION, ADJUSTMENT, ALTERATION,  
SERVICE OR MAINTENANCE CAN CAUSE PROPERTY DAMAGE,  
INJURY OR DEATH. READ THE INSTALLATION, OPERATING AND  
MAINTENANCE INSTRUCTIONS THOROUGHLY BEFORE INSTALLING  
OR SERVICING THIS EQUIPMENT.**

### Responsibilities:

- A) **The responsibility of the manufacturer** is to supply suitable, comprehensive instructions and recommendations for proper operation and maintenance.
- B) All operations, maintenance and repair of this or any appliance must be performed by properly trained and qualified personnel, and all such operations, maintenance and repair must be performed in a diligent manner. It is the **responsibility of the owner/operator** to insure proper training and diligence of any person coming into contact with either the subject units or the output (product, exhaust or otherwise) of the subject units. It is the **responsibility of the owner/operator** to ensure that the subject units are installed and operated in accordance with OSHA Standard 1910.263.
- C) A regular periodic program of cleaning, inspection and maintenance must be established and comprehensive maintenance records maintained. It is the **sole responsibility of the owner/operator** to establish, schedule and enforce the frequency and scope of these programs in keeping with recommended practice and with due consideration given to actual operating conditions. For suggested cleaning schedule visit our Website @ [www.lcbakery.com](http://www.lcbakery.com) First click on Manuals, then click on Equipment Cleaning under Operation and Programming Manuals, or call LBC @ 1-888-722-5686 to have one faxed.
- D) This appliance must be operated within limits, which will not exceed its working limits. It is the **responsibility of the user** to operate this appliance in accordance with the rules and limits described in this manual and the published product specification sheet, and in accordance with the directions and instructions of the owner/operator of the appliance or employer, and in accordance with applicable federal, state, and local laws and ordinances.

## **Safe Operating Rules:**

You must read and understand this section before you operate this appliance.

### Hot surfaces

- The appliance may be hot. Do not enter the appliance and remain for more than 30 seconds if the appliance is hot. Do not contact hot surface in the appliance interior without proper protection. Contact with hot surfaces can cause serious burns and loss of skin and hair and the use of limbs.
- Always check to see if racks are too hot to handle without mitts.
- The appliance door may not stay open and may close on its own.
- Oven racks that are used in the process of cooking or baking may be hot. Avoid contact with hot racks. Use appliance mitts or protective pads to handle racks or baking pans. Alert others to the hazard of hot racks.

### Hot Water and Steam

- This appliance produces steam and hot water in the process of proofing. Do not contact or stand in the area where steam or hot water are or may be produced. Steam and hot water are very hot and will cause serious burns and loss of skin hair and the use of limbs, serious injury to eyes and internal organs. Excessive contact with steam or hot water can even result in loss of life.
- Steam produced by the appliance and vented out the bottom of the door can cause the floor to become wet. If the floor becomes wet, wipe up or mop up the water and alert other employees of the hazard.
- Steam and/or hot water may be expelled through the appliance drain. This should be connected to a proper air/gap drain during installation to allow excess water to be evacuated from the work area. Steam and hot water from the drain are very hot and will cause serious burns and loss of skin and hair and the use of limbs, serious injury to eyes and internal organs. Spills, spillage and slipping
- Use caution to avoid slipping when operating this appliance or when around the appliance. This appliance is intended to be connected to a sanitary air-gap drain. If the drain becomes clogged, continued use of the appliance may result in water spilling onto the floor in the appliance and in front of the appliance or in the general work area around the appliance. If the drain becomes clogged and water spills on the floor:
  - Stop using the appliance to prevent more water spillage.
  - Mop up and clean up any water in the appliance, on the floor in front of the appliance or in the surrounding work area.
  - Alert other personnel, employees, customers, or observers of the hazard.
  - Notify supervisor, servicer or maintenance persons and have the drain unclogged.
- In the normal operation of the appliance, product intended for baking or cooking may spill onto the floor. If product spills onto the floor:
  - Mop up and clean up any product in the appliance, on the floor in front of the appliance or in the surrounding work area.
  - Alert other personnel, employees, customers, or observers of the hazard.

### Sharp Edges and Pinch Hazards

- Use caution to avoid contact with sharp edges. Doors, covers, air shutters and tray slides all may have edges that can cut or snag skin and cloths. Use caution when working on, cleaning, or servicing the appliance and racks.
- Never place any part of your body, including but not limited to hands feet and fingers in the hinge side of the door. Keep hands feet and fingers out of the path of the loading door when closing, to avoid pinching.

- Use caution when rolling an oven rack in and out of the appliance or when rolling an oven rack across the floor. Fingers, toes, and other parts of the body that are in the path of the oven rack may be pinched by the oven rack wheels or may be crushed by the weight of the rack and product on the rack.
- Use caution when opening the loading door to avoid opening the door over your foot or someone else's foot, arms, fingers, or other body parts.

#### Strains, Over Extension, Over Exertion and Lifting Hazards

- Caution, pans of product may be hot and may be heavy. Lifting of hot pans may cause you to react to contact with hot surfaces and result in spilling or dropping the product which can cause physical harm.
- Use caution when loading and unloading pans from the appliance. Pans may be heavy and result in sprains, strains, or injury to back, arms, hands, or legs. Do not lift more than you are safely capable of lifting.
- Use caution when moving an oven rack as the rack may be heavy. Moving a heavy oven rack can result in strain or injury to back, arms, hands, or legs. A heavy rack may be difficult to control or stop. Avoid putting yourself and others in danger.

#### Other precautions

- Caution do not stand on top of the appliance for any reason unless the appliance is turned off and you are an authorized servicer. The top of the appliance does not have proper fall protection to be accessed or to provide elevation to reach other locations or other objects. Do not stand on or climb on oven racks as they may move and result in a fall.
- Do not store anything on top of the appliance.
- Do not stay inside the appliance when it is hot.
- Do not close the appliance door while you or someone else is inside. Do not allow anyone else to enter the appliance or close the door on themselves or anyone else. Do not allow the door to be closed on anyone and allow anyone to block the door opening so that the person cannot exit. Do not lock or block the door of the appliance with anyone inside or allow anyone else to lock the appliance with someone else inside.
- Do not lock or block the door of the appliance unless the door is already closed, and you are sure that there is no one inside the appliance. The loading door can be unintentionally or intentionally locked and then closed, trapping a person inside.

#### Smoke, Flames, Fire

- Warning do not operate the appliance or any other appliance if you smell smoke. Turn the appliance off and contact your supervisor or an authorized service provider.
- Warning, if you see flames or smoke in or around the appliance:
  - Turn the appliance off and contact your supervisor authorized service provider.
  - Call 911 or contact fire safety personnel in accordance with your employer's emergency plan.
  - **DO NOT OPEN THE APPLIANCE DOOR** as this will allow oxygen to reach any flames and cause injury to persons, property damage and may cause loss of life.
- Warning do not operate the appliance or any other appliance if you hear bangs, pops or other abnormal noises. Turn off the appliance and contact your supervisor or authorized service provider.
- Caution: do not allow any flammable materials to be put into the appliance. the following materials are flammable:
  - Gasoline and petroleum products, including wax and tar
  - Wood chips, wood, and paper
  - Hair
  - Flour dust and fine corn meal that can become airborne
  - Parchment baking paper that is old or has become loose from the baking pan.
  - Charred food, baked products, or any other burned material
  - Animal and vegetable fats that vaporize or become overheated
  - Smoke

- Do not operate the appliance if an attached fire suppression system or fire alarm system is dysfunctional or has been discharged. Contact your supervisor or contact the fire safety system servicer.
- If a fire suppression system discharges while you are operating the appliance, turn off the appliance and follow your employer's emergency plan, or exit the building or work area.

#### Electrical Hazard

- Do not operate the appliance if electrical covers are removed or there are frayed, burned, or exposed wires or if any live electrical terminals are exposed. Turn off the appliance and any circuit breaker or disconnect supplying electrical power to the appliance as described in your employer's emergency plan.
- Do not operate the appliance if any circuit breaker or fuse connected to the appliance becomes tripped and cannot be reset. Contact your supervisor or authorized servicer or electrician to correct the condition before operating the appliance. Alert other employees and service personnel to the hazard.
- Do not operate the appliance if you feel an electrical shock when in contact with the appliance or oven racks or other devices attached to the appliance. Contact your supervisor or authorized servicer or electrician to correct the condition before operating the appliance. Alert other employees and service personnel to the hazard.

#### Improper Operation

- Do not operate the appliance if covers, doors or latches are removed.
- Do not operate the appliance if any other person has applied a lock-out on the electrical or has tagged the appliance in a way to suggest that the appliance not be used. Contact your supervisor for further instructions or refer to your employers' safety plan.

#### Health and Safety in Baked or Cooked Products

- For the safety and health of those who will consume goods produced using the appliance, use all caution and diligence to prevent the ingestion of any item or material that is unsafe or unfit for human consumption.
- Do not use the appliance if you see any material floating in the air in the appliance or if you see any foreign matter in the finished food product.
- Do not use the appliance if you smell unfamiliar smells or if you smell any odor that you know to be unhealthy.
- Do not under-cook any product that can carry bacteria such as but not limited to e-coli, salmonella, or any other pathogen.
- Do not cook, roast, or handle any meat or meat product that contains any known diseases or pathogens.
- Do not use this appliance to roast, hold or cook any protein product.
- Do not use this appliance to disinfect or sanitize anything that requires sanitation or disinfection.
- In all cases, follow the Food-safe practices as mandated by law and your employer.

## Warnings, Cautions, Dangers:

**WARNING** MOVING PARTS HAZARD. FOLLOW LOCKOUT PROCEDURES BEFORE REMOVING AIR DUCT OR EVAPORATOR FAN GUARDS

**WARNING** ELECTRICAL HAZARD BEHIND UPPER FRONT TRIM. FOLLOW LOCKOUT PROCEDURES BEFORE SERVICING.

**WARNING** THE LBC BAKERY LRP SERIES PROOFER PRODUCES HUMIDITY WHICH WILL NATURALLY CONDENSE AND ACCUMULATE WATER ON THE INTERIOR FLOOR CAUSING IT TO BECOME SLIPPERY. ADJACENT EXTERIOR FLOOR MAY ALSO BECOME SLIPPERY. USE EXTREME CAUTION WHEN WALKING IN OR AROUND THIS APPLIANCE.

**DANGER** DO NOT STORE OR USE GASOLINE OR OTHER FLAMMABLE VAPORS OR LIQUIDS IN THE VICINITY OF THIS OR ANY OTHER APPLIANCE.

**NOTICE** For best results, always allow your proofer to reach set temperature and humidity before putting product in.

**NOTICE** For best results, proof at lower temperatures rather than higher.

**NOTICE** To dry proof: Set humidity to the lowest setting (either 45% or less). At this setting the humidity generator is turned off and will not produce humidity.

**NOTICE** When the actual humidity is less than 46% display will show 45. When the actual humidity is higher than 45%, display will show the actual humidity.

**NOTICE** Service on this or any other LBC BAKERY equipment must be performed by qualified personnel only. Consult your authorized service agency directory or call the factory at 1-888-722-5686 or go to [WWW.LBCBAKERY.COM](http://WWW.LBCBAKERY.COM) for the service agent nearest you.

**CAUTION** THIS APPLIANCE, WHEN INSTALLED, MUST BE ELECTRICALLY GROUNDED IN ACCORDANCE WITH LOCAL CODES, OR IN THE ABSENCE OF LOCAL CODES, WITH THE NATIONAL ELECTRICAL CODE, ANSI/NFPA 70-1996.



**CAUTION**

FOR INSTALLATION IN CANADA THE INSTALLATION MUST BE IN ACCORDANCE WITH CAN/CGA-B149.1&2 OF THE INSTALLATION CODE, AND LOCAL CODES WHERE APPLICABLE. ALL ELECTRIC WIRING MUST BE IN ACCORDANCE WITH THE CURRENT CANADIAN ELECTRICAL CODE, C22.1 PART 1. GROUNDING THIS APPLIANCE MUST CONFORM TO CANADIAN ELECTRICAL CODE, CSA C22.2.

**WARNING**

INSTALLATION OF THE UNIT MUST BE DONE BY PERSONNEL QUALIFIED TO WORK WITH ELECTRICITY AND PLUMBING. IMPROPER INSTALLATION CAN CAUSE INJURY TO PERSONNEL AND /OR DAMAGE TO EQUIPMENT. UNIT MUST BE INSTALLED IN ACCORDANCE WITH ALL APPLICABLE CODES

**WARNING**

MOVING PARTS HAZARD. FOLLOW LOCKOUT PROCEDURES BEFORE REMOVING AIR DUCT OR EVAPORATOR FAN GUARDS

**WARNING**

ELECTRICAL HAZARD BEHIND UPPER FRONT TRIM. FOLLOW LOCKOUT PROCEDURES BEFORE SERVICING.

**WARNING**

THE LBC BAKERY LRP SERIES PROOFER PRODUCES HUMIDITY WHICH WILL NATURALLY CONDENSE AND ACCUMULATE WATER ON THE INTERIOR FLOOR CAUSING IT TO BECOME SLIPPERY. ADJACENT EXTERIOR FLOOR MAY ALSO BECOME SLIPPERY. USE EXTREME CAUTION WHEN WALKING IN OR AROUND THIS APPLIANCE.

**Safety Procedures:****Lockout Procedure**

1. Announce lockout to other personnel.
2. Turn both heat and control power off at main panel.
3. Clear unit of all personnel.
4. Test lockout by turning power switch on and observing if control panel displays or fan(s) come on. Check heater circuit with voltmeter.
5. Perform necessary repairs or tests.
6. Clear unit of personnel before restarting.
7. Turn power on at main panel.
8. Announce unit is "on" to other personnel.



## Proofer Control Operation

LBC proofers are designed for simple operation. Once the controls are set, the proofer can operate all day long with or without the use of the controls four main timers.

- **Turning the proofer Off and On.**

 To turn the proofer on, press the power button on the control panel. The control display should immediately light up, showing the current temperature humidity. Depending on other option settings, the 4-channel timer should also light up. In some cases, the 4-channel timer will stay on all the time.

 To turn the proofer off, press the power button again. The display will turn off. The circulation fan on the climatizer(s) will continue to operate for an additional 10 minutes to allow the climatizer to cool down.

- **Automatic features.**

The proofer control is equipped with programmable features that manage the use of energy and water when the proofer is not being used.

1. **Open Door Shut down.** If the loading door(s) are left open for an extended period, the proofer control assumes that the operator is not using the proofer or has finished the shift. The proofer will automatically shut down in the same manner as when the power button is pressed. The length of time that the open-door shut down will delay can be adjusted or can be turned off completely. The recommended setting is 10 minutes.
2. **Closed Door Idle delay.** If the proofer loading door(s) are left closed for a period longer than the normal proofing cycle, the control assumes that there is no product in the proofer. Each time the doors are opened, the delay timer is reset, and the proofer will operate as set. If the closed-door idle delay time is exceeded, the control will continue to stay on and control the internal temperature but will stop producing humidity. This helps to reduce the amount of condensate on the walls and floor, extends the life of components, as well as allowing any water treatment system to recharge, such as a reverse osmosis system. The length of time of the delay can be adjusted or can be turned off completely. The recommended setting is 50 minutes.

- **Temperature and Humidity Settings.**

The proofer control display shows the measured temperature or humidity in the proofer while it is operating. To adjust temperature and humidity settings:



- Press the button with the thermometer icon to select the temperature setting. Press the up or down arrow buttons to adjust the temperature setting. Press the button with the thermometer icon again to view the actual temperature.

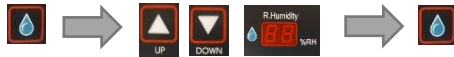

- Press the button with the water drop icon to select the humidity setting. Press the up or down arrow buttons to adjust the humidity setting. Press the button with the water drop icon again to view the actual humidity.

Propper settings of temperature and humidity are important for good proofing, and are important for keeping the proofer clean and operating properly. Here are setting suggestions.

- **Temperature:** The optimal dough temperature is 70 to 80 degrees F. To raise the temperature of the dough to 80 degrees, the proofer should not be set to operate above 100F.
- **Humidity:** Humidity is injected into the proofer to prevent drying of the product. The lower the proofing temperature, the less humidity is needed. Under normal circumstances the proper setting for humidity is 70% to 85%.
- **Timer settings.**

There are four independent timers on the proofer control. These are intended to be used to time individual racks of product. Here are setting suggestions:

- Press the start/stop button  once to start the timer, indicated by the blinking decimal point.

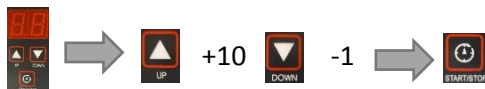

- Adjust the timer by pressing the up-arrow button to increase time by 10 minutes. Press the down-arrow button to decrease the time by one minute. The timer will reset to the last set time after the alarm is stopped.
- When the timer sounds, remove the rack of product that is complete or was put into the proofer first.
- When the timer reaches zero and sounds, it will also flash to indicate that it is complete. Press start/stop button  to stop the alarm.



## Retarder/Proofer Control Operation

LBC Retarder/Proofers are designed for simple operation. Once the controls are set, the unit can automatically cycle through the process of Retarding and into the Proof process to fit your operating schedule. The Retarder/Proofer control requires only one button press per day to initiate the automatic process.

- **Turning the retarder/proofer Off and On.**

The retarder/proofer may be turned off completely if desired. When turned off, the automatic operation is shut off, but the time clock is still working and programming is not erased.

**POWER** Press the “Power” button on the right of the control display to turn the unit on. The display will then light up to show the current time in 24-hour format. The unit is in “Manual” mode and requires that you either press the “Auto/Manual” button to switch to the automatic process or select the process you wish to run on the unit.

- **Selecting Manual Processes.**

The retarder/proofer can be operated manually in one of four modes. The refrigerating modes are “Hold” and “Retard”. Both modes will cause the retarder to maintain a cold setting.

**HOLD** The “Hold” mode is usually set to the colder setting, usually at about 34 degrees F. Hold is used to prevent defrosting of frozen product that is put into the unit. The Retarder/Proofer cannot be used to freeze any product.

**RETARD** The “Retard” mode is usually set to 38 to 40 degrees F. Retard is used to prevent fresh dough from rising or is used to slow defrost frozen dough. The recommended retard time is 8 hours. Note, the retarder/proofer is not intended to operate as a retarder continually. Retarding for more than a day will result in ice accumulation in the refrigeration system.

The heating and humidifying modes are “Rest” and “Proof”.

**REST** The “Rest” mode is generally set to a temperature halfway between the retarding setting and the proofing setting (say 65 F), and a humidity setting of about 45%. The rest process is intended to allow dough time to warm up to about





room temperature before the proofing process begins. Rest should be scheduled for about 90 minutes.

 The “Proof” mode is the time when the dough product is conditioned for baking. Proofing allows the yeast or leavening agent to do its work and make the dough puff up. Proofing should also keep the dough from skinning over while the dough is rising. Recommended settings are 90 degrees F and 80% relative humidity.

To select a manual mode, press the button marked with the process you wish to use.

- **Setting Process Temperature and Humidity**

Each process has a specific temperature setting. Rest and Proof also have specific humidity settings. To set the temperature and humidity for each process:





- 1)  Select manual mode with the “Auto/Manual” button.
- 2)  Select the process you wish to set.
- 3)  Press the “Temperature” button below the temperature display. The temperature display will show the current set point.
- 4)  Press the up or down arrow buttons below the time display to adjust the temperature set point. This temperature setting will only affect the process you have chosen.
- 5)  Press the “Temperature” button to return the downplay to the actual temperature.

Note: When the process is selected and the temperature or humidity set point is shown, the retarder/proofer will heat or cool and humidify to these settings. You do not need to start the retarder/proofer.

- **Setting the Clock**

LBC Retarder/Proofer controls are equipped with a real-time clock. This is used to determine when the automatic features of the control will happen.

To change the time of day on the clock:

- 1) Press the POWER button to turn the retarder/proofer control off.
- 2)  Press and hold the TIME button for 5 seconds to enter the Clock-setting mode. The control will display "t-Yr \_\_ for the current year.
- 3)  Press the Up or Down Arrow buttons to adjust year.
- 4)  Press the TIME button to advance to the current month. Adjust using the Up or Down Arrow buttons.
- 5) Press the TIME button to advance through the other settings: "t-mo" for month, "t-do" for day, "t-wo" for week, "t-ho" for hour (in 24-hr clock time), "t-mi" for minute, "t-SE" for seconds.
- 6)  Press the POWER button to exit the clock adjusting mode.

- **Setting the Automatic Cycle Timers**

**To set up the control for automatic operation, there are some things that must be determined.**

1. When will you bake?
2. How long will it proof?
3. How long will it rest (warm up to room temperature)?
4. When will you load the retarder proofer?

Setting up the automatic timer requires that you work backwards in time. It is always best to do this on paper first.

- “When you will bake” will be entered into the automatic timer as the **Finish** time.
- Subtract from the finish time the time required to proof to determine the **Start Proof** time.
- Subtract from Start Proof how long the product should rest to determine the **Start Rest** time. By experience we know that 90 minutes works best for this.
- Next determine when you want to load the retarder with product to determine **Start Retard**.
- Last subtract 1 hour to allow for adequate cool-down. This is the **Start Hold** time.

Here is an example:

Say you want to bake frozen bread for French loaves. You will be finished with your proofer at 3:00 PM or at 15:00. You plan on baking the first load the next day at 8:00 AM, 08:00. You generally proof the bread for 40 minutes.

- The **Finish Time** will be 08:00.
- The product will proof for 40 minutes so the **Start Proof** time will be 07:20.
- The product will need 90 minutes to rest (rise in temperature to room temperature) so the **Start Rest** time will be 05:50.
- The retarder/proofer should be allowed 1 hour to cool down so the **Start Retard** time will be 16:00.
- The **Hold Start** time will be 15:00.

**To enter the start times:**

1. Press the Time button to illuminate the LED that indicates **Hold Start** time. The decimal points in the hours display will be on to indicate you are setting hours. Press the up or down button to change the hour of the day, 15. Press the Temperature button to toggle to the minutes display. The decimal points in the minutes display will indicate you are setting minutes. Use the up or down buttons to adjust the minutes to 00.
2. Press the Time button to illuminate the LED that indicates **Retard Start** time. Use the up or down buttons along with the Temperature button to set 16:00.
3. Press the Time button to illuminate the LED that indicates **Rest Start** time. Use the up or down buttons along with the Temperature button to set 05:50.
4. Press the Time button to illuminate the LED that indicates **Proof Start** time. Use the up or down buttons along with the Temperature button to set 07:20.
5. Press the Time button to illuminate the LED that indicates **Finish** time. Use the up or down buttons along with the Temperature button to set 08:00.

- **Starting or Restarting an Automatic Retard/Proof Cycle.**

1. Turn on the retarder/proofer.
2. Press the “Auto/Manual” button to start the Auto cycle.
  - a. If the current time is between the process start times, the retarder/proofer will begin operating the relevant process.
  - b. If the current time is after the “Proof” start time or before the “Hold” start time, the retarder/proofer will “Wait”, indicated by the amber LED light in the cycle graph below the time display.
3. The Automatic Retard/Proof cycle will always end in the proof cycle. The retarder/proofer will continue to retard indefinitely until you turn the unit off or press the “Auto/Manual” button to restart the Automatic Retard/Proof cycle for the next day.

- **Automatic features.**

The retarder/proofer control is equipped with programmable features that manage the use of energy and water when the unit is not being used.

1. **Open Door Shutdown.** If the loading door(s) are left open for an extended period in the proofing mode only, the control assumes that the operator is not using the unit or has finished the shift. The retarder/proofer will automatically shut down in the same manner as when power button is pressed. The length of time that the open door shutdown will delay can be adjusted or can be turned off completely. The recommended setting is 10 minutes.
2. **Closed Door Idle delay.** If the retarder/proofer loading door(s) are left closed during the proof cycle only for a period longer than the normal proofing cycle, the control assumes that there is no product in the unit. Each time the doors are opened, the delay timer is reset, and the proofer will operate as set. If the closed-door idle delay time is exceeded, the control will continue to stay on and control the internal temperature but will stop producing humidity. This helps to reduce the amount of condensate on the walls and floor, extends the life of components, as well as allowing any water treatment system to recharge, such as a reverse osmosis system. The length of time of the delay can be adjusted or can be turned off completely. The recommended setting is 50 minutes.

## **Other Operating Precautions and Hints**

- **Condensation:** Proper settings in the proofer are important to avoid some problems that can occur due to excess condensation.
  - Setting the temperature too high will cause excess condensation on the walls and floor of the proofer. The walls and floor are heated by the proofer when the unit is turned on, but when the proofing temperature is too high, the walls and floor will not reach a temperature above the dew point for that temperature and humidity setting. As a result, there is a continuous condensation of moisture. This uses excess water and causes the interior of the proofer to become less sanitary.
  - Trying to dry the proofer by increasing the temperature setting will cause even more condensation.
  - Setting the humidity too high can result in a constant injection of humidity, which drastically reduces the life of proofer components and uses an excess amount of water. In the case of a water system treated by an RO system this can drain the reserve tank on the RO system to where it will not produce humidity or can in some cases will cause the RO system to bypass untreated water into the proofer system.
- **Uneven proofing:**
  - The process of proofing is much more passive than baking in an oven. The process is not just raising the temperature of dough, but also holding the temperature while the yeast in the dough does the work. Having the proofer set to a temperature which is too high, will cause higher temperatures on the outside of dough products while the inside is still trying to warm up. This same affect happens to a full rack of product, where the outside edges of the rack proof more than the inside.
  - Overloading a proofer or a rack can also promote uneven proofing. The rack with product needs space around it for air to circulate. Try to keep at least two sides of each rack open for circulation. Additionally, loading product into the rack without adequate space between sheet pans. The best rack spacing is to leave a minimum of 1.5" space above the top of the finished, baked product.
  - Never remove a rack from a cooler and place it directly into a proofer. This will cause excess condensation on the cold product and will affect the environment around other warmer racks in the proofer.
  - In proofers that have capacity for more than 1 rack, it is best to insert the new rack in the back of the proofer. This makes it much easier to check product that is closer to ready without disturbing all the racks. This also reduces the probability of a cold rack causing the proofer heat to turn on too much which would dry out racks that have been in the proofer longer.
- **Pass-thru Proofer and Retarder/Proofer operations:**

The operation of a pass-thru proofer or retarder proofer is much different from the operation of a single ended unit in the following ways:

Pass-thru operation can involve more than one operator. During proofing the operator on the front-end places racks into the unit as they are ready to load. The operator on the back-end pulls racks from the proofer when they are ready. It is

important that the loading of racks and the removal of racks are timed properly so that the whole operation is efficient. Here are important things to note:

1. The production process that feeds racks of product to the proofer should match or be slightly less than the capacity of the ovens that will be baking the product. If there is a lot of product ready to proof, do not load it into the proofer if it cannot be baked in a timely manner once it comes out.
2. Pass-thru units may be equipped with synchronized timers. This allows for a timer to be started on loading side and be canceled on the un-load side. The timer does not need to be coordinated with a specific door or lane of racks. Rather, when a rack is put into the unit to proof, any available timer can be started and when a timer reaches "00" and sounds, the rack that is closest to the unload side is ready to remove.
3. When multiple lanes of product are loaded into the proofer, they should always be loaded simultaneously so that they can be removed together.
4. Some units are equipped with sensors and controls on both ends. The control scan be set so that the proofer is turned on and off from one end. The temperature and humidity settings must be set on each end. The multiple controls should always be set to the same temperature and humidity. With a control on each end, the proofer can compensate for the colder temperature of a rack when it is first loaded without overheating the racks that are near completion.

## Replacement Parts List

### Climatizer

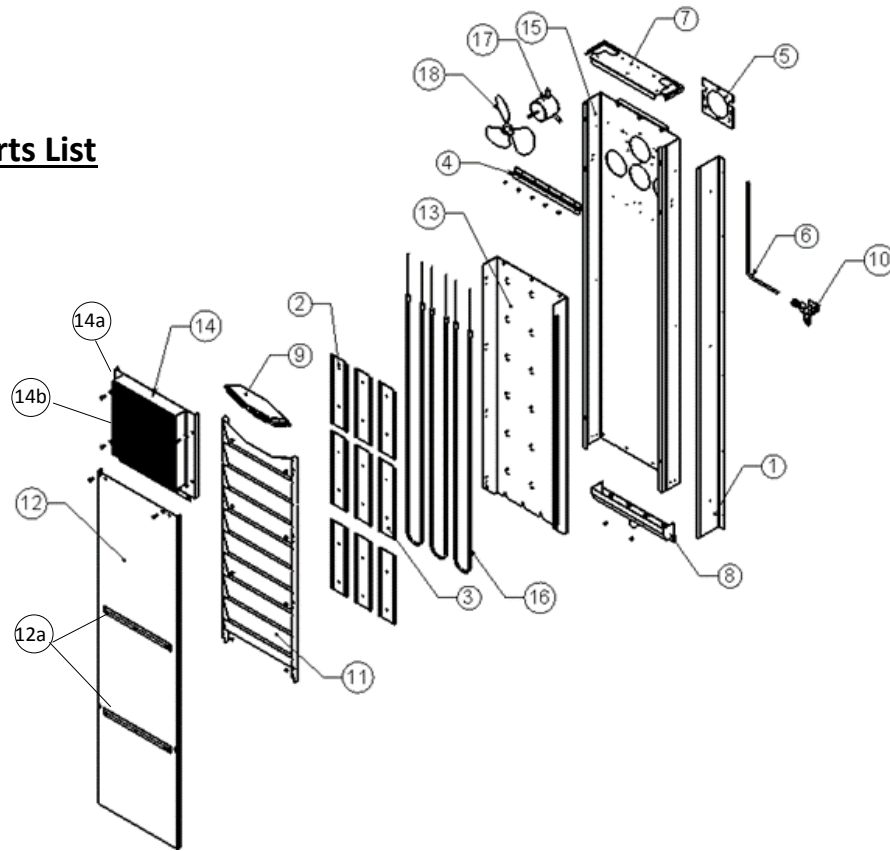

Item	Parts		Description
	Legacy	Current	
1	155-158		Bracket Side - Climatizer
2	155-160-1		Element Clamp top and bottom
3	155-160-2		Element Clamp middle
4	155-161-1		Bottom clamp Bracket
5	155-162-1		Plate, Fan Mount
6	155-167		Copper Tube, 10MM
7	N/A	155-526	Mounting Cleat, Upper – LRP4
8	155-723	155-530	Drip Pan
9	N/A	155-533	Filler Plate Assembly, Spray Deflector
10	155-722		Spray Assembly
*11	**155-732		<b>Spray Separator</b>
12	155-150	155-802	Element Cover Assembly
12a	71100-12		Bumper
*13	155-161b	155-803	<b>Element Base Assembly</b>
14	155-804		Fan Cover Assembly
14a	155-303		Screen Cover
14b	155-151		Cover Fan
*15	155-162	155-805	<b>Duct Channel Assembly</b>
16	11162-09		Heating Element, 240 VAC, 2200 Watts
17	30200-55		Motor, 220 Volt, 1/15 HP
18	71500-11-1		Fan Impeller

## Electrical

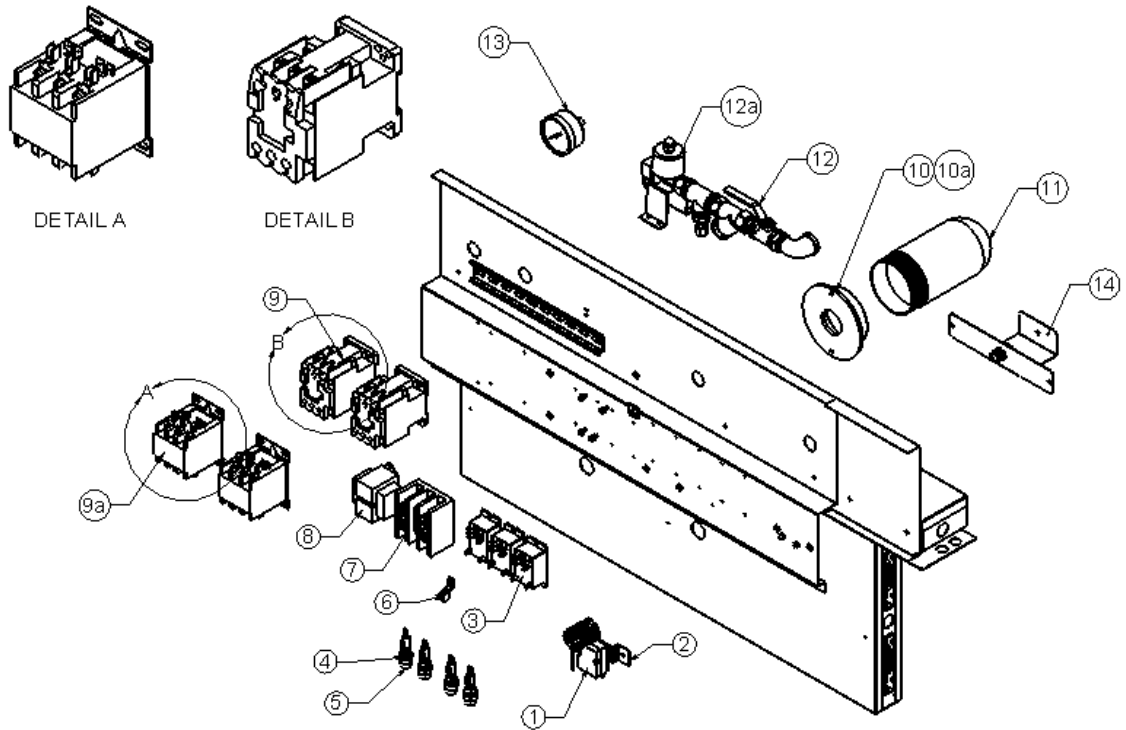

Item	Parts				Description
	LRP1	LRP2N	LRP2S	LRP3	
1		30701-27			High Limit Thermostat, Proofer
2		155-308			Bracket, T-stat Mount
3		30701-05			Relay, 2-pole, 30 Amp – 24 VAC Coil
4		30901-02			Fuse Holder for 15A Fuse
5		30900-01			Fuse 15A (ABC-15)
6		31200-02			GROUNDING LUG
7		30500-07			Terminal Block, 3-Pole, 125 Amp
8		31400-26			XFMR 120/208/240 Primary 12-24 40VA
*9		30700-76			<b>Contactor, 3-Pole, 50A, CU-32R</b>
*9a		30700-17			<b>Contactor, 3-Pole, 50A, M 98</b>
10		31602-06			Lamp Socket Rack Proofer
10a		31603-04-1			<b>250V</b> 50W CFL Light Bulb
11		31602-06-1			Lamp Globe
12		70101-200			Water Connection
12a		70403-01			Solenoid Valve, 24 VAC. 1/4 NPT
13		70404-03			Gauge 0-100 PSI 4X515
14		155-725-3			Hi Limit Bulb Assembly

**\*NOTE:** Either set of contactors may be present. Replace Item 9 or 9a to its match in likeness.

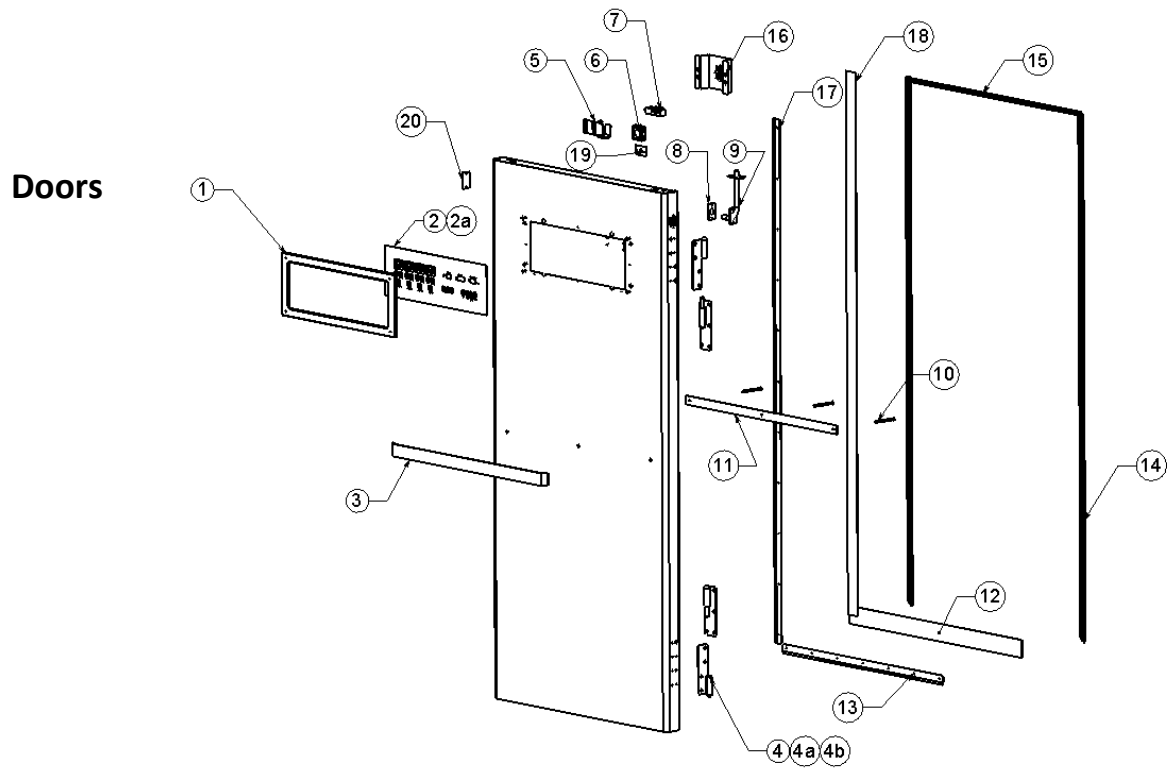

Items	Parts				Description
	LRP1	LRP2N	LRP2S	LRP3	
1	155-330-1	155-330-1	155-330-1	155-330-1	Control Bracket
2	40102-65-1	40102-65-1	40102-65-1	40102-65-1	Proofer Control w/ Timer
2a	40102-63	40102-63	40102-63	40102-63	Retarder/Proofer Control
3	155-702	155-702-17	155-702	155-702-1	Door Handle
4	155-806	N/A	N/A	N/A	Complete Hinge Set LRP1 (1 Req.)
4a	N/A	155-807			Hinge Assembly, Left Door (2 Req.)
4b	N/A	155-808			Hinge Assembly, Right Door (2 Req.)
5	70602-24	70602-24	70602-24	70602-24	Door Closer, Strike
6	30200-42	30200-42	30200-42	30200-42	Fan, Micro-5VDC
7	40106-05	40106-05	40106-05	40106-05	Temp/Humidity Sensor
8	155-338-2	155-338-2	155-338-2	155-338-2	Plate Control Wireway
9	155-672-1	155-672-1	155-672-1	155-672-1	Wire Assembly
10	20109-51	20109-51	20109-51	20109-51	Screw, Door Handle
11	71100-14	71100-19	71100-14	71100-14	Bumper- Door
12	155-114	155-114-17	155-114	155-114-1	Bottom Seal
13	155-128	155-128-17	155-128-24	155-128-1	Bottom Retainer
14	N/A	72602-21-1-L	72602-21-1-L	72602-213-1-L	Door Seal, Left
15	72602-21-2	72602-21-1-R	72602-21-1-R	72602-213-1-R	Door Seal, Right
16	155-410	155-410	155-410	155-410	Bracket, Sensor Guard
17	N/A	155-127	155-127	155-127	Center Retainer
18	N/A	155-131	155-131	155-131	Center Seal
19	155-338-3	155-338-3	155-338-3	155-338-3	Seal Wireway
20	155-338B	155-338B	155-338B	155-338B	Plate, Hole Cover



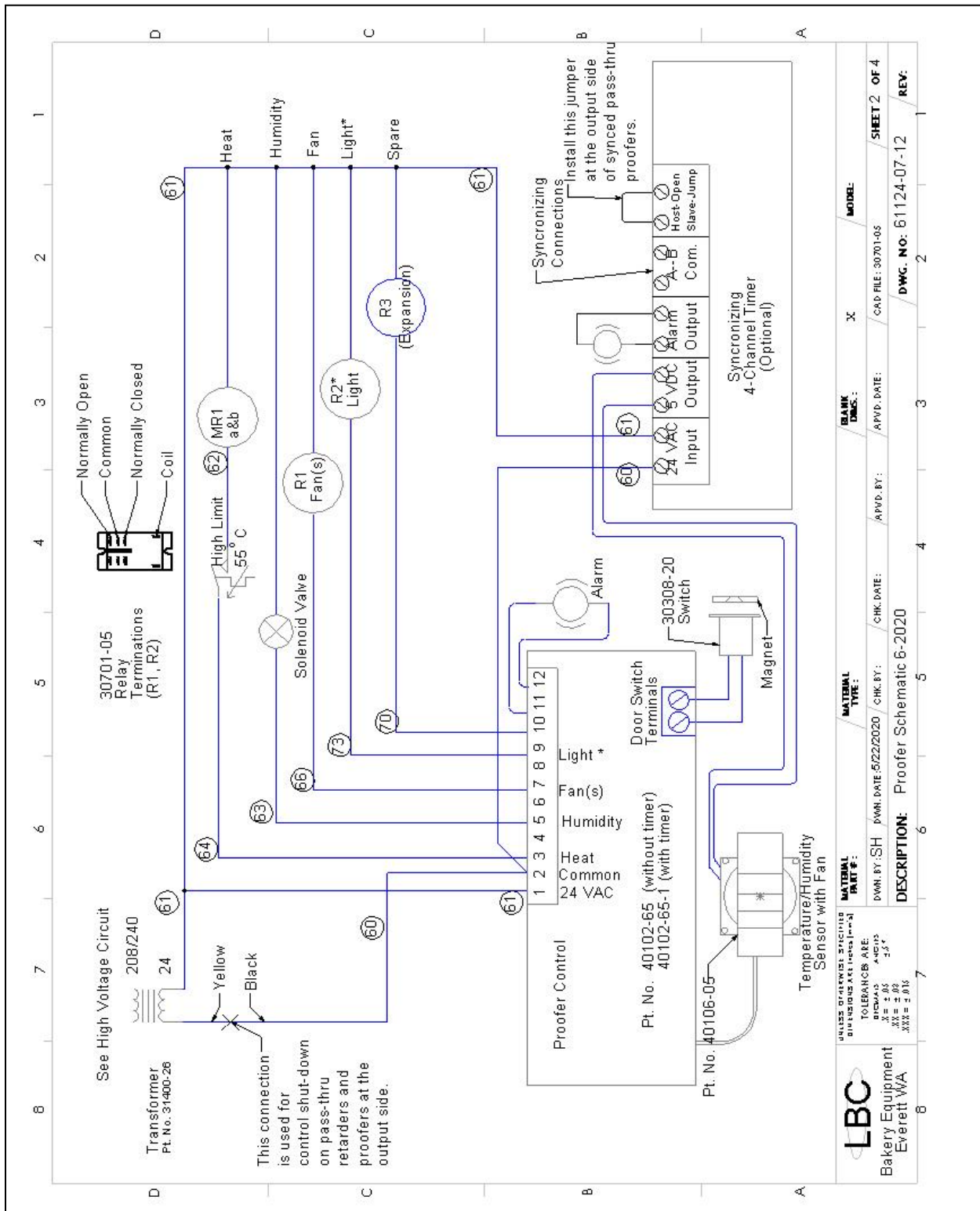

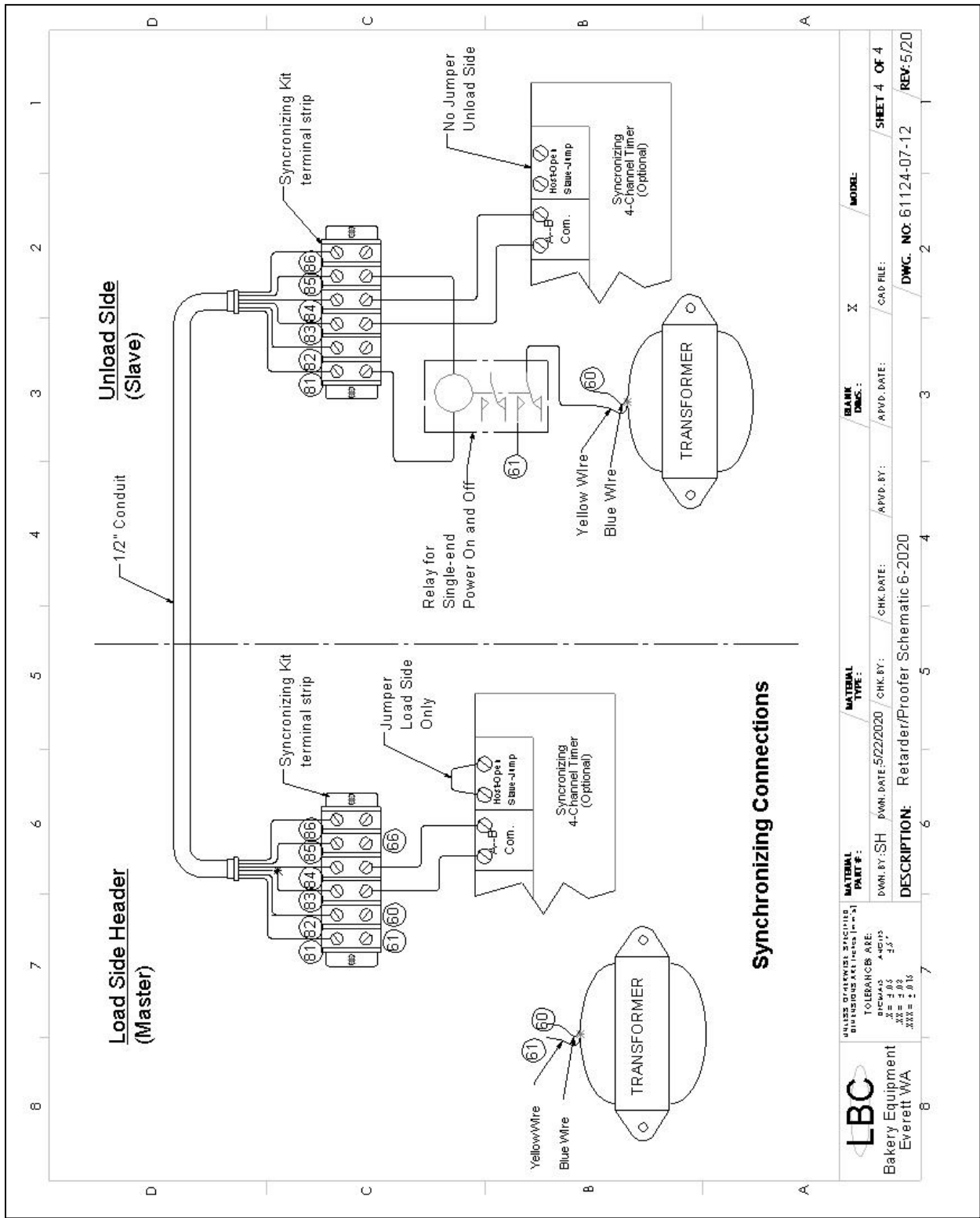

<b>LBC</b> Bakery Equipment Everett WA	DIMENSIONS: DRAWING DIVISIONS ARE: 1/8" (12.5)	<b>MATERIAL PART #:</b>	<b>MATERIAL TYPE:</b>	<b>BAK. DIM.:</b>	<b>MODEL:</b>
	TOLERANCES ARE: FRACTIONS: 1/16" DECIMALS: .005 ANGLES: .5° HOLE: .005 SHAFT: .010	DWN. BY: SH PWN. DATE: 5/22/2020 CHK. BY:	DWN. DATE: 5/22/2020 CHK. DATE:	APVD. BY:	APVD. DATE:
DESCRIPTION: Retarder/Proofer Schematic 6-2020					
				DWG. NO: 61124-07-12	REV: 5/20

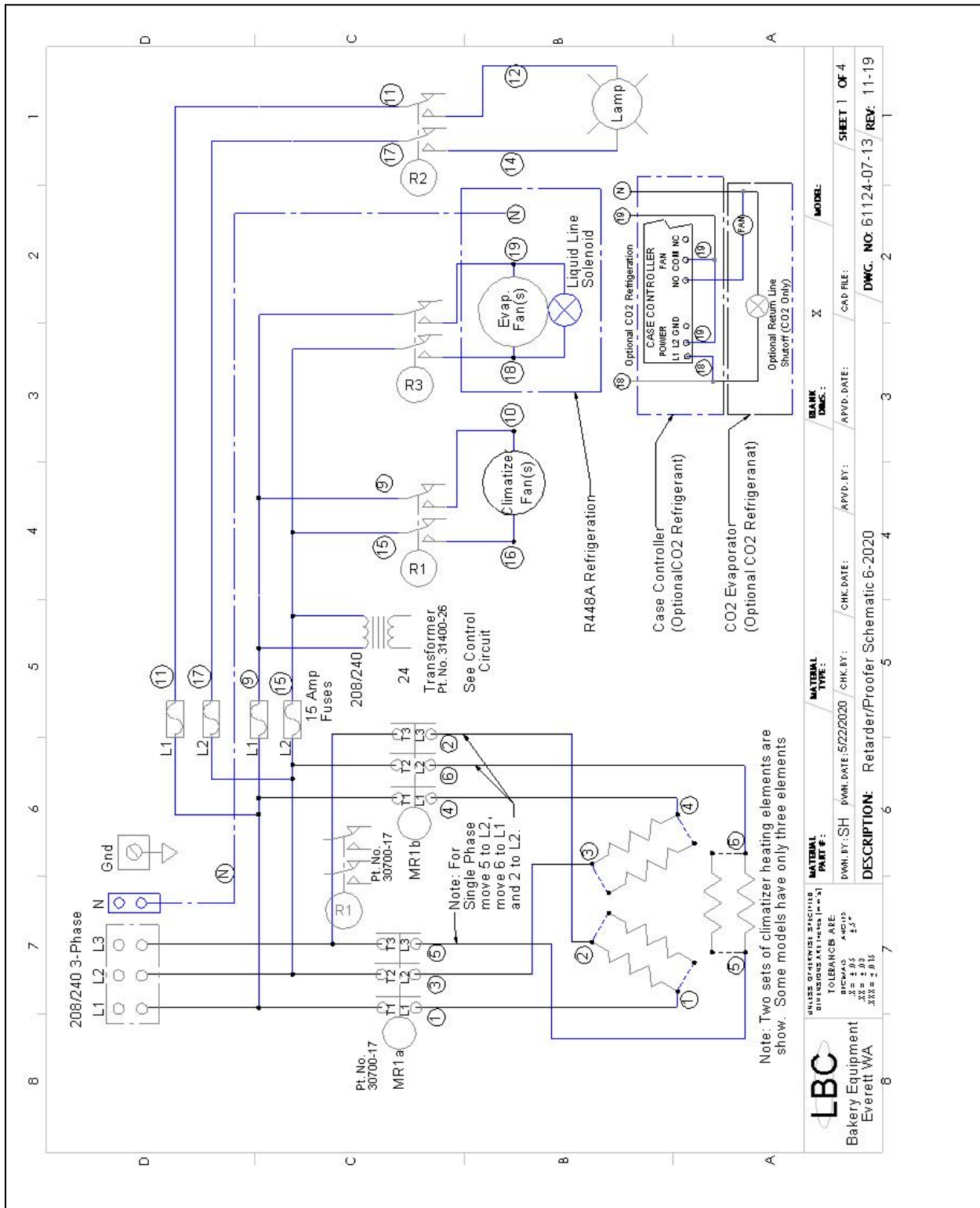

<b>MATERIAL PART #:</b>	<b>MATERIAL TYPE:</b>	<b>BANK DGS:</b>	<b>MODEL:</b>
30700-17	MR1b	X	X
<b>DATE:</b>	<b>CHK BY:</b>	<b>APVD DATE:</b>	<b>CD FILE:</b>
5/22/2020	SH		
<b>DESCRIPTION:</b>	<b>RETARDER/PROOFER SCHEMATIC 6-2020</b>		
<b>LBC</b> Bakery Equipment Everett WA	<b>SHEET 1 OF 4</b>		
	<b>DWG. NO: 61124-07-13 REV: 1-1-19</b>		

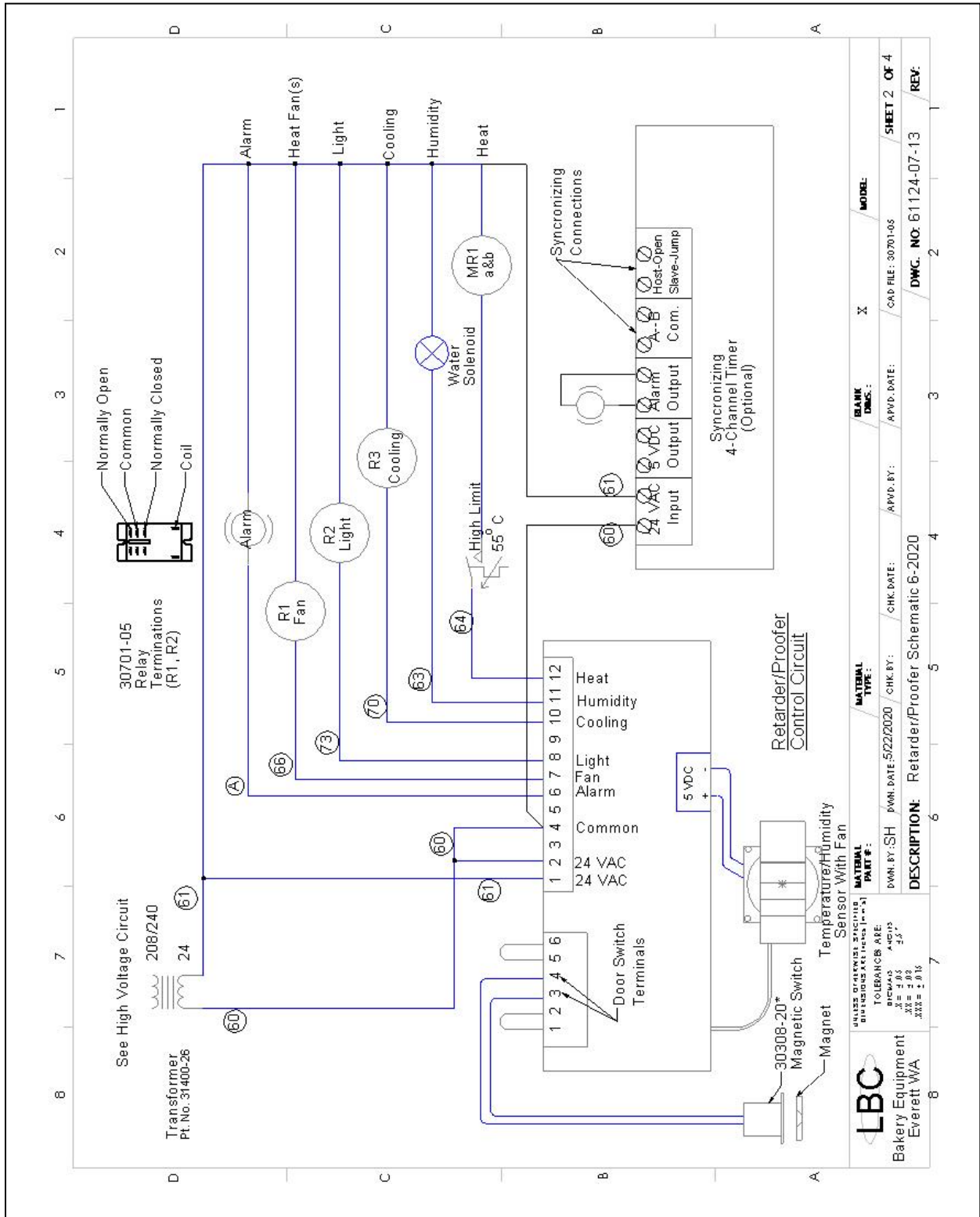

<b>LBC</b> Bakery Equipment Everett WA	UNLESS OTHERWISE SPECIFIED DIMENSIONS ARE IN INCHES ( ) = 1/16"	<b>MATERIAL TYPE:</b> DWG BY: SH    PWN DATE: 5/22/2020    CHK BY:	<b>BLANK DIMS:</b> X	<b>MODEL:</b>
	TOLERANCES ARE: FRACTIONS    DECIMALS .XX = 3/32    .0015 .XXX = 1/16"	<b>DESCRIPTION:</b> Retarder/Proofer Schematic 6-2020	APVD. BY:    APVD. DATE:	CAD FILE: 30701-05
				<b>DWG. NO:</b> 61124-07-13
				<b>REV:</b>

## Proofer Control Set-up and configurations

LBC proofers are available in a broad variety of sizes to be used in a variety of applications. Controls are provided that can be configured to maximize performance, minimize energy usage, control water consumption, and reduce wear and tear. This section covers the settings and peripheral components of the control and how to properly configure them.

### **Proofer Control Functions under 0008 access code:**

To access the Proofer function settings 0008:

- 1) Press the POWER button to turn the proofer control off.
- 2) Press the “Up” arrow button and the “Down” Arrow button simultaneously until "0000" appears in the temperature and humidity displays.
- 3) Press the Up or Down Arrow button to change the display to "0008".
- 4) Press the Time button to advance through the functions.
- 5) Press the up or down arrows to change the setting.
- 6) Press the Time button to advance to “oT”.
- 8) Press the POWER button to exit the function settings.
  - **oT:** This setting can be set to cause the control to alarm if it is slow to heat up. This feature is more confusing to operators than helpful and should be set to “00”.
  - **rT:** This setting is used to change the displayed temperature by offsetting it up or down. This should be used only when compared to an accurate thermometer. *Example: If the displayed temperature is 90F and an accurate temperature sensing device displays 85, the offset can be decreased by 5 degrees from its current setting. So, if the offset is at -7, decreasing the offset by 5 degrees will result in an offset of -12.*
  - **rA:** This setting is used to change the displayed relative humidity by offsetting it up or down. This should be used only when compared to an accurate hygrometer. *Example: If the displayed relative humidity is 75% and an accurate hygrometer displays 85%, the offset can be increased by 10% from its current setting. So, if the offset is at -4, increasing the offset by 10% will result in an offset of +8.*
  - **Td:** This setting will limit how far from the set point the temperature display can vary. It is not recommended to use this at any setting other than “00”.
  - **Ad:** This setting will limit how far from the set point the humidity display can vary. It is not recommended to use this at any setting other than “00”.

## Proofer Control Functions under 0088 access code:

To access the Proofer function settings 0088:

- 1) Press the POWER button to turn the proofer control off.
- 2) Press the “Up” arrow button and the “Down” Arrow button simultaneously until "0000" appears in the temperature and humidity displays.
- 3) Press the Up or Down Arrow button to change the display to "0088".
- 4) Press the Time button to advance through the functions.
- 5) Press the up or down arrows to change the setting.
- 6) Press the Time button to advance to “TP”.
- 8) Press the POWER button to exit the function settings.
  - **TP:** This setting controls the PID function of the heat control. Leave this at “00”.
  - **Tt:** This setting controls the length of the PID cycle. Leave it set to “00”.
  - **Tc:** This setting controls the frequency of the PID cycle. Leave it set to “00”.
  - **Ac:** This setting sets the frequency of the humidity cycle. Set this number to “32”. If the humidity is slow to recover with a load in the proofer, lower this number to “16”.
  - **Ao:** This setting controls how long the humidity output will be on per humidity cycle. “Set it to 04”. If the humidity is overshooting when loaded, lower this to “02”.
  - **oH:** This setting determines how high the humidity can overshoot before the alarm will sound. This feature is more confusing to the operator than it is helpful and should be left at “00”.
  - **dF:** This function is inactive.
  - **FI:** This function is inactive.
  - **oL:** This setting turns on the output alarm for the proofer only and will not affect the timers.
  - **To:** This setting determines how high the temperature can be set by the operator. Set this to “105”. If the proofer is to be used for products that require a higher set point, increase this number as required. *Note: If the proofing temperature is too high, there will be increased condensation in the proofer on the walls and ceiling.*
  - **oP:** This setting will determine how long the proofer door can be left open before the proofer automatically shuts off. Setting this to “00” will defeat the automatic shut-off feature. Having the feature turned on will help to extend the life of the proofer.
  - **CL:** This setting will adjust how long the proofer doors can be left closed before the control automatically stops producing humidity. This feature greatly extends the life of the proofer by stopping humidification when the proofer does not have a load.

<b>Proofer control</b>				
<b>Function settings Code 0008</b>				
<b>Function</b>	<b>Short Name</b>	<b>Description</b>	<b>Factory set point</b>	<b>Range</b>
<b>oT</b>	Heat timer alarm	Sounds the alarm if the set temperature is not reached within the indicated number of minutes.	00	0 - 99
<b>rT</b>	Temperature Calibration	Changes the displayed temperature in Degrees F to match that of a calibration thermometer.	00	+25, -25
<b>rA</b>	Humidity Calibration	Changes the displayed relative humidity to match that of a calibration meter.	00	+25, -25
<b>Td</b>	Temperature Lock	Limits the range of temperature variance shown in degrees.	00	0 - 99
<b>Ad</b>	Humidity Display Limit	Limits the range of displayed humidity from the set point. 00 turns this function off.	00	0 - 99
<b>Proofer control</b>				
<b>Function settings Code 0088</b>				
<b>TP</b>	Proportion Factor	Sets the ratio of proportional on time to temperature difference.	07	7
<b>Tt</b>	Heat cycle time	Sets the length of the PID cycle in seconds.	00	00
<b>Tc</b>	Temperature Cycle Rate	This controls how often the temperature proportional output will turn on.	15	15
<b>Ac</b>	Humidity Cycle time	Sets the length of time in seconds for each humidity cycle.	32	16 - 32
<b>Ao</b>	Humidity On time	Sets the "on" time in seconds for humidity in each cycle.	04	0 - 20
<b>oH</b>	Upper Humidity Alarm	This sets the alarm range for humidity overshoot. It should be set to 00 to turn it off.	00	0 - 99
<b>dF</b>	N/A	This function is inactive.	00	00
<b>FI</b>	N/A	Inactive	00	00
<b>oL</b>	Alarm Off/On	Turns alarm output on or off.	01	00 - 01
<b>To</b>	Max Set Temp	Limits the maximum temperature the operator can set.	105	00 - 01.22
<b>oP</b>	Open Door Shut-off	Sets how long the door can be open before the proofer turns off. Set to 00 to disable.	10	0.0 - 99
<b>CL</b>	Unattended Humidity Shut-off	Sets how long the proofer can be left unattended (Door Closed) before the humidity turns off.	45	0.0 - 99

## Retarder/Proofer Control Set-up and configurations

LBC Retarder/proofer are available in a broad variety of sizes to be used in a variety of applications. Controls are provided that can be configured to maximize performance, minimize energy usage, control water consumption, and reduce wear and tear. This section covers the settings and peripheral components of the control and how to properly configure them.

### **Retarder/Proofer Control Functions under 0008 access code:**

To access the Retarder/Proofer function settings:

- 1) Press the POWER button to turn the retarder control off.
- 2) Press the “Up” arrow button and the Auto/Manual button simultaneously until "0000" appears in the temperature and humidity displays.
- 3) Press the Up or Down Arrow button to change the display to "0008".
- 4) Press the Time button to advance through the functions.
- 5) Press the up or down arrows to change the setting.
- 6) Press the Time button to advance to F1.
- 8) Press the POWER button to exit the function settings.
  - **F1:** This setting is used to change the displayed temperature by offsetting it up or down. This should be used only when compared to an accurate thermometer. *Example: If the displayed temperature is 90F and an accurate temperature sensing device displays 85, the offset can be increased by 5 degrees from its current setting. So, if the offset is at -7, increasing the offset by 5 degrees will result in an offset of -2.*
  - **F2:** This setting is used to change the displayed humidity by offsetting it up or down. This should be used only when compared to an accurate hygrometer. *Example: If the displayed humidity is 90% and an accurate humidity sensing device displays 85%, the offset can be decreased by 5% from its current setting. So, if the offset is at -7, decreasing the offset by 5 degrees will result in an offset of -12.*
  - **F3:** This setting will limit how far from the set point the temperature display can vary. It is not recommended to use this at any setting other than “00”.
  - **F4:** This setting will limit how far from the set point the humidity display can vary. It is not recommended to use this at any setting other than “00”.
  - **F5:** This setting controls the PID function of the heat control. Leave this at “00”.
  - **F6:** This setting controls the length of the PID cycle. Leave it set to “00”.
  - **F7:** This setting controls the frequency of the PID cycle. Leave it set to “00”.
  - **F8:** This setting sets the frequency of the humidity cycle. Set this number to “32”. If the humidity is slow to recover with a load in the proofer, lower this number to “16”.
  - **F9:** This setting controls how long the humidity output will be on per humidity cycle. “Set it to 04”. If the humidity is overshooting when loaded, lower this to “02”.
  - **F10:** This setting determines how long the control will wait before starting the refrigeration cycle. This delay is meant to protect the compressor from overheating. This does not need to be greater than “00”.

- **F11:** This setting determines what the dead band is for cooling. Raising this number will increase the difference between cooling on and off. Set this to “2.0”.
- **F12:** This setting changes the heating dead band. Increasing this will increase the fluctuation in temperature. Set this to “0.5”.
- **F13:** Not used.
- **F14:** This setting determines how long the light will be on after the light button is pressed. If this is set to “00”, the interior light will stay on until you turn it off.
- **F15:** This setting determines how long the alarm will sound on the retarder/proofer control only. It will not affect the 4-channel timer alarm. Set this to “0.0”.
- **F16:** This setting determines how long the retarder will be in the defrost mode once it starts. Set this to 30 for best results.
- **F17:** This setting determines how often the retarder/proofer will defrost. Set to “08” for 8 hours and the best results.
- **F18:** This setting can be used to control heated defrost when used. Set this to 32. Electric heated defrost is not used on retarder/proofer.
- **F19:** This setting determines what temperature the proofer portion of the control can reach before it sounds an alarm. Set this to “140”.
- **F20:** This setting determines how high the user can set the temperature in any mode. Set this to “105” for best results. *Note: If the proofing temperature is too high, there will be increased condensation in the proofer on the walls and ceiling.*
- **F21:** This setting determines the minimum set point of the retard and hold modes. Set this to “32” for best results.
- **F22:** This setting determines the scale of the temperature display. When set to “C”, the display will show the Celsius temperature, followed by “C”.
- **F23:** This setting will adjust how long the retarder/proofer doors can be left closed in “Proof” mode before the control automatically stops producing humidity. This feature greatly extends the life of the retarder/proofer by stopping humidification when there is no product in the retarder/proofer. **If there is no door switch, this must be set to “00”.**
- **F24:** This setting will determine how long the door can be left open in proofing mode before the unit automatically shuts off. Setting this to “00” will defeat the automatic shut-off feature. Having the feature turned on will help to extend the life of the proofer. “10” works best. **If there is no door switch, this must be set to “00”.**
- **F25:** This setting controls the function of the output at Pin 7. For retarder/proofer **built before June of 2020, with 4 or more 24 VAC relays, set this to “0”.** For Retarder/Proofer built June 1 of 2020 with only 3-24 VAC relays, set this to “1”. With this set to “1”, the output at Pin #7 will only be on in the rest or proof mode. This will not work with older units.

<b>Retarder/Proofer control Function settings</b>				
<b>Function</b>	<b>Short Name</b>	<b>Description</b>	<b>Factory set point</b>	<b>Range</b>
<b>F1</b>	Temperature Calibration	Increase the value to increase the display and lower the actual temperature.	00	+25, -25
<b>F2</b>	Humidity Calibration	Increase the value to increase the display and lower the actual humidity.	00	+25, -25
<b>F3</b>	Temperature Lock	Limit the range of temperature variance shown in degrees.	00	0 - 9
<b>F4</b>	Humidity Lock	Limit the range of humidity variance shown in degrees.	00	0 - 9
<b>F5</b>	Heat PID range	Sets the range for PID control in degrees.	07	0 - 99
<b>F6</b>	Proportion Factor	Sets the ratio of proportional off/on time to temperature difference.	00	0 - 30
<b>F7</b>	Heat cycle time	Sets the length of the PID cycle in seconds.	15	1 - 99
<b>F8</b>	Humidity Cycle time	Sets the length of time in seconds for each humidity cycle.	32	1 - 99
<b>F9</b>	Humidity On time	Sets the "on" time in seconds for humidity in each cycle.	04	0 - 20
<b>F10</b>	Refrigeration Defer time	Sets how long the control will delay the turning on of the cooling system in minutes.	0.0	0.0 - 9.9
<b>F11</b>	Cooling Dead Band	Temperature difference between cooling off and cooling on.	2.0	0.0 - 9.9
<b>F12</b>	Heating Dead Band	Temperature difference between heating on and heating off.	0.5	0.0 - 9.9
<b>F13</b>	Not used	Set to 0.5	005	0 - 9
<b>F14</b>	Light on time	How long the light will be on in seconds. "0.0" = light will be on indefinitely.	0.5	0.0 - 9.9
<b>F15</b>	Alarm on time	Determines how long the alarm will sound before it turns off, in seconds. "0.0" means the alarm will stay on indefinitely.	0.0	0.0 - 9.9
<b>F16</b>	Defrost time	Length of the defrost time in minutes. "00" = no defrost.	30	0.0 - 9.9
<b>F17</b>	Defrost delay	Determines how long between starts of the defrost cycle in hours. "00" = no defrost.	08	0.0 - 9.9
<b>F18</b>	Defrost Temperature	Determines what temperature ends the defrost cycle, when a thermistor is imbedded in the evaporator.	32	00 - 200

<b>F19</b>	Over temperature alarm	Determines when the alarm will sound if the temperature runs away.	140	32 - 200
<b>F20</b>	Maximum temp set point	Determines how high the user can set the temperature.	105	32 - 140
<b>F21</b>	Minimum temp set point	Determines how low the user can set the temperature.	34	0 - 32
<b>F22</b>	F/C	Determines the scale of the temperature display.	F	F - C
<b>F23</b>	Unattended proofer delay	Determines how long the proofer can continue to humidify without having the door opened in minutes.	45	0 - 99
<b>F24</b>	Open Door turn-off delay	Determines how long the door can be left open in the proofing mode before the unit turns off in minutes.	10	0 - 20
<b>F25</b>	Legacy option	"0" = for old retarders, "1" = for new retarders after the addition of the door switch	0	0 - 1

## Limited Warranty

*LBC Bakery Equipment ("LBC Equipment") has been skillfully manufactured, carefully inspected and packaged to meet rigid standards of excellence. LBC Bakery Equipment, Inc. (LBC) warrants products produced and sold by LBC and its duly authorized agents, against defects in materials and workmanship within the following limitations:*

### **What is Provided:**

- Limited replacement parts as specified below, including standard ground shipping from LBC or service parts center when required.
- Limited labor for repair as specified below, including authorized service agent's transportation, portal to portal, up to one hundred (100) miles round trip and two (2) hours travel time.
- LBC, or an authorized service representative, will repair at LBC's sole discretion, any new LBC equipment, according to the limits and exclusions listed in this limited warranty.

### **Coverage Period:**

*Extending from the date of shipment from LBC or its duly authorized dealer/distributor for the specified period.*

- LBC Equipment (Rack Ovens, Proofers, Retarder/proofers, Retarders, Rotisseries, Deck Ovens, Conveyor Ovens) shall be warranted for a period of one (1) year, limited parts and labor.
- Heat Exchanger Tubes on oven models LRO-1G5 and LRO-2G5 for a period of ten (10) years, limited parts and labor.
- Replacement Parts purchased from LBC or Authorized supplier shall be warranted for a period of ninety (90) days after installation by an authorized LBC service agent.

### **Conditions:**

- Covered equipment must have been properly installed and according to the requirements of the installation manual and all applicable local codes.
- An Equipment Start-Up must have been performed by an authorized LBC servicer and the completed start-up form returned to LBC.
- The equipment shall not have been abused, misused or neglected or used for purposes other than intended by LBC.
- Water connected to the appliance shall have been in compliance with the following requirements:
  - Cold water, 40 to 80 PSI (Hot water to Rotisseries)
  - pH between 7 and 7.5
  - Conductivity less than 1/500,000  $\Omega$  per inch
  - Total dissolved solids less than 100 ppm
  - Hardness from 6.3 to 8.8 grains per gallon
  - Maximum Salinity and Ion content:
    - Chlorides:* < 30 ppm
    - Sulfates:* < 40 ppm
    - Iron:* < 0.1 ppm
    - Copper:* < 0.05 ppm
    - Manganese:* < 0.05 ppm

It is the responsibility of the purchaser to install and maintain the water supply to the appliance. Failure to provide satisfactory water quality to the appliance in accordance with the operating manual requirements can cause damage to internal components and will VOID the warranty.

### **Conditions (cont):**

- All repair work is to be performed by an LBC authorized service agent.
- Equipment must be at the operating location of the original purchaser/user and shall not have been resold or reclaimed by another party.
- LBC equipment is for commercial use only. If sold as a component of another (OEM) manufacturer's equipment, or if used as a consumer product, such equipment is sold AS IS and without any warranty.
- Conditions of sale of the equipment shall have been met in full.
- The request for repair shall be made within the limited period of the warranty.

### **Failure to meet the above conditions will void this warranty**

#### **Exclusions:**

*This warranty does not cover the following:*

- Routine general maintenance, or periodic adjustment
- Consumable items including but not limited to, light bulbs, glass, door gaskets, rack bumpers etc.
- Thermostat calibration after the first 30 days of use
- Air and gas burner adjustments
- Fuse replacement
- Cleaning and adjusting burners, pilot burners or heat exchangers
- Rack oven shutter adjustments
- Repairs, adjustments and corrections in the refrigeration portion of retarder/proofers resulting from the improper installation
- Retightening of screws and fasteners
- Failures caused by erratic or inadequate electrical, water, ventilation or gas service
- Unauthorized repairs
- Premature rusting, corrosion, or mineral build up caused by incoming water
- Attached water treatment systems
- Expedited freight on replacement parts other than standard ground shipments
- Ordinary wear and tear
- Use of the equipment for purposes other than those intended including non-commercial use such as residential or domestic
- Appliances installed outside the contiguous U.S., including Alaska and Hawaii, and Canada
- Incidental costs, charges, loss of business and damages as incurred by the user or others as a result of the use or failure of the equipment
- Work and workmanship of the authorized service agent or others in the repair of the equipment
- Other failures that are beyond the reasonable scope of this warranty
- Damages caused during shipment are to be reported to the carrier, are not covered under this warranty, and are the sole responsibility of the purchaser/user
- Natural disaster

This warranty is exclusive and in lieu of all other warranties, expressed or implied, including expressed or implied warranties of merchantability or fitness for a particular purpose, each of which is hereby expressly disclaimed. The remedies described herein are exclusive and in no event shall LBC be liable for special, consequential or incidental damages for the breach or delay in the performance of this warranty.