



Model SFP-M50 Pizza Dough Moulder Operation and Service Manual

LBC Bakery Equipment, Inc.

6026 31st Ave NE

Tulalip, WA 98271

USA

Phone: 888-RACKOVN (888-722-5686)

Fax: 425-642-8310

Email: parts@lcbakery.com

Website: www.lcbakery.com

Read First

THIS MANUAL MUST BE RETAINED FOR FUTURE REFERENCE. READ, UNDERSTAND AND FOLLOW THE INSTRUCTIONS AND WARNINGS CONTAINED IN THIS MANUAL. IT IS THE RESPONSIBILITY OF THE OWNER/OPERATORS OF THIS APPLIANCE TO TRAIN, SUPERVISE AND AUTHORIZE ANY PERSON DESIGNATED AS AN OPERATOR. ALL OPERATORS MUST READ AND UNDERSTAND THIS MANUAL.



- A The responsibility of the manufacturer is to supply suitable, comprehensive instructions and recommendations for proper operation and maintenance.
- B All operations, maintenance and repair of this or any appliance must be performed by properly trained and qualified personnel, and all such operations, maintenance and repair must be performed in a diligent manner. It is the responsibility of the owner/operator to ensure proper training and diligence of any person coming into contact with either the subject units or the output (product, fumes or otherwise) of the subject units. It is the responsibility of the owner/operator to ensure that the subject units are installed and operated in accordance with OSHA Standard 1910.263.
- C A regular periodic program of cleaning, inspection and maintenance must be established and comprehensive maintenance records maintained. It is the sole responsibility of the owner/operator to establish, schedule and enforce the frequency and scope of these programs in keeping with recommended practice and with due consideration given to actual operating conditions.
- D The appliance must be operated within limits which will not exceed its working limits. It is the responsibility of the user to operate this appliance in accordance with the rules and limits described in this manual and the published product specification sheet, and in accordance with the directions and instructions of the owner/operator of the appliance or employer, and in accordance with applicable federal, state and local laws and ordinances.

Table of Contents

CHAPTER	PAGE
Read First	2
Safe Operating Rules	4
Equipment Description	5
Operation	7
Cleaning and Maintenance	8
List of Parts	9
Schematic	14
Notes	15
Warranty	16

Safe Operating Rules

YOU MUST READ AND UNDERSTAND THIS SECTION BEFORE YOU OPERATE THIS APPLIANCE

Sharp Edges and Pinch Hazards

- Use caution to avoid contact with sharp edges. Doors, covers, etc. may have edges that can cut or snag skin and clothes. Use caution when working on, cleaning or servicing the appliance.
- Keep hands and fingers out of the path of movable parts to avoid pinching.

Strains, Over-Extension, Over-Exertion and Lifting Hazards

- Use caution when loading or unloading heavy product from the appliance. Product may be heavy and result in sprains, strains or injury to back, arms, hands or legs. Do not lift more than you are safely capable of lifting.

Smoke or Fire Hazard

- If you see flames or smoke in or around the appliance:
 - Turn the appliance off and contact your supervisor or an authorized service provider.
 - Call 911 or contact fire safety personnel in accordance with your employer's emergency plan.
- Do not operate the appliance or any other appliance if you hear bangs, pops or other abnormal noises. Turn off the appliance and contact your supervisor or authorized service provider.
- Do not operate the appliance if an attached fire suppression system or fire alarm system is dysfunctional or has been discharged. Contact your supervisor or contact the fire safety system servicer.
- If a fire suppression system discharges while you are operating the appliance, turn off the appliance and follow your employer's emergency plan, or exit the building or work area.

Electrical Hazard

- Do not operate the appliance if electrical covers are removed or there are frayed, burned or exposed wires or if any live electrical terminals are exposed. Turn off the appliance and any circuit breaker or disconnect device supplying electrical power to the appliance as described in your employer's emergency plan.
- Do not operate the appliance if any circuit breaker or fuse connected to the appliance becomes tripped and cannot be reset. Contact your supervisor or authorized servicer or electrician to correct the condition before operating the appliance. Alert other employees and service personnel to the hazard.
- Do not operate the appliance if you feel an electrical shock when in contact with the appliance or other devices attached to the appliance. Contact your supervisor or authorized servicer or electrician to correct the condition before operating the appliance. Alert other employees and service personnel to the hazard.

Improper Operation

- Do not operate the appliance if covers or other components are removed.
- Do not operate the appliance if any other person has applied a lock-out on the electrical supply or has tagged the appliance in a way to suggest that the appliance not be used. Contact your supervisor for further instructions or refer to your employer's safety plan.

Other Precautions

- Do not stand on the appliance.
- Do not store anything on top of the appliance.

Health and Safety in Cooked Products

- For the safety and health of those who will consume goods produced through the use of the appliance, use all caution and diligence to prevent the ingestion of any item or material that is unsafe or unfit for human consumption.
- Do not use the appliance if you see any material floating in the air in the appliance or if you see any foreign matter in the finished food product.
- Do not use the appliance if you smell unfamiliar smells or if you smell any odor that you know to be unhealthy.
- In all cases, follow all food-safe practices as mandated by law and your employer.

Equipment Description (part 1 of 2)

YOUR LBC PIZZA DOUGH MOULDER WAS MANUFACTURED TO RIGID STANDARDS

Advantages

- Intuitive and easy-to-use design.
- Will mould pizza dough, calzones, pie crusts, pita bread, tortillas and many other flat dough products.
- Capacity of up to 300 pieces per hour.
- On button and off/emergency stop button located on front of moulder.
- Loading and discharge trays face forward, reducing production time.
- Top-feed design with Teflon feeder rollers.
- Two-pass operation.
- Cover is safety interlocked. Moulder will not operate when it is removed.
- Discharge tray with Teflon counterweight is easily removable for cleaning.
- Dough thickness scale is conveniently located on side of appliance.
- Teflon roller scraper assembly is easy to remove for cleaning.
- Compact design. Appliance requires little space.
- Low noise when operating.

Construction

- Top, sides, front, rear, trays, rollers and critical components are made from rigid stainless steel.
- All material is of sufficient thickness and strength to extend equipment life.
- Rollers are driven by robust 1/2" [13mm] roller chain.
- Standard 110VAC moulder is supplied with 6' [1.8m] power cord.
- Available in 208VAC, 1-phase and 3-phase configurations.

Rollers

- Roller gap is adjustable from 0.16" [4mm] to 0.4" [10mm].
- Roller length is 19.7" [500mm].

Dimensions

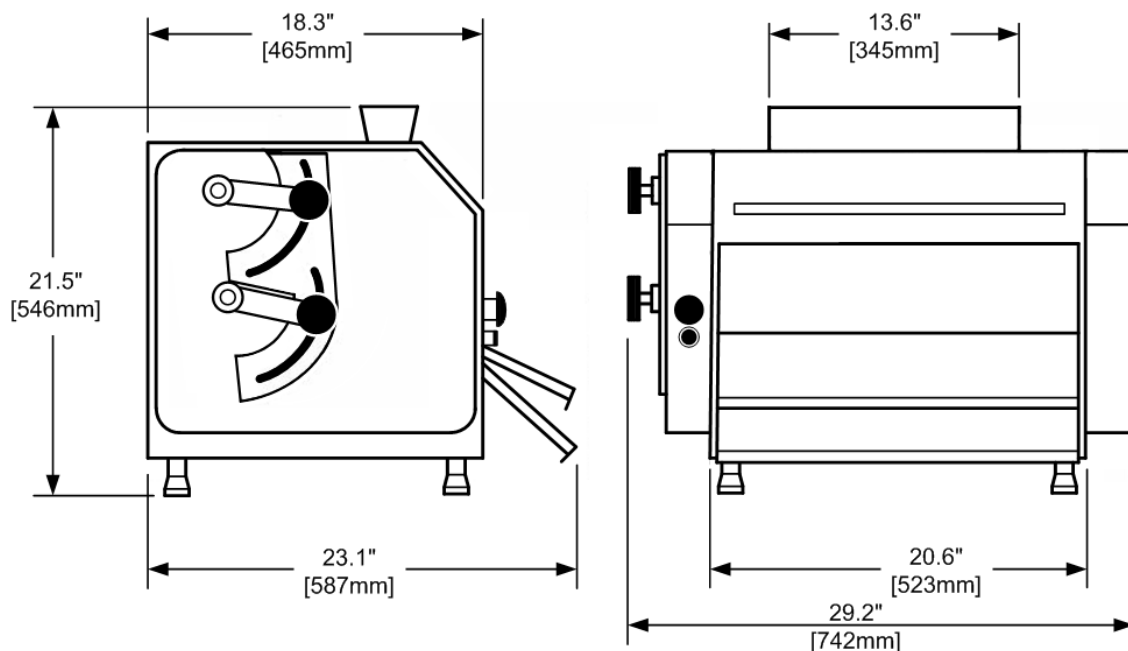

Equipment Description (part 2 of 2)

Electrical Specifications

Voltage	kW	Amps	Min Circuit Ampacity		Max Breaker Size	
			1 Phase	3 Phase	1 Phase	3 Phase
120	0.75	6.5	9.5		15	
208	0.75	7.7	9.5		15	
208	0.75	4.4		6.0		15

Shipping Information

Weight		Freight Class
Actual	Shipping	
250lbs [113kg]	380lb [172kg]	85

Operation

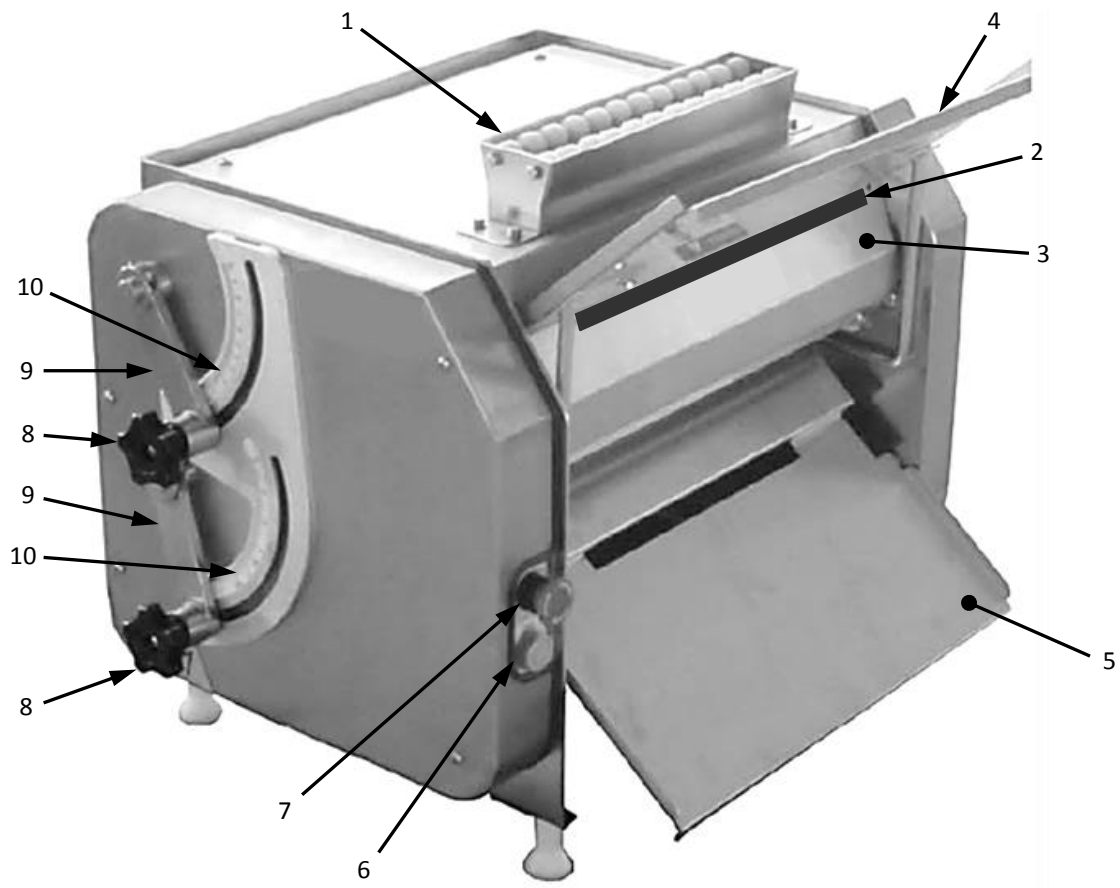

Procedure

- A Close safety interlock cover (3).
- B Adjust roller gap with adjustment handles (9) and adjustment scales (10). Tighten knobs (8) to lock settings.
- C Press start button (6).
- D Move loading tray (4) to lowest position.
- E Feed slightly preformed dough into top feeder (1).
- F Dough will be flattened and oval and will slide out onto loading tray (4).
- G Turn dough 90° (quarter turn) on loading tray (4).
- H Move loading tray (4) to highest position. This will set roller gap. Allow dough to slide into inlet slot (2).
- I Completed, moulded dough will slide out onto discharge tray (5).
- J To continue moulding, repeat operations described above (except item C). To stop, turn off moulder at stop button (7).

Cleaning and Maintenance



WARNING

ALWAYS TURN OFF AND LOCKOUT/TAGOUT ELECTRICAL SUPPLY TO APPLIANCE BEFORE CLEANING OR PERFORMING MAINTENANCE.



WARNING

KEEP WATER AND SOLUTIONS OUT OF CONTROLS. NEVER SPRAY OR HOSE CONTROL CONSOLE.



NOTICE

Never use chlorine-based cleansers on this appliance. Chlorine corrodes stainless steel.

NOTICE

To maintain optimum safety and performance, it is recommended that a program of regular maintenance be implemented. It is the sole responsibility of the user to establish, schedule and enforce such a program. Although the actual service schedule will vary depending on the environment in which the equipment is operating, it is recommended that the above be done by an LBC-authorized service representative every six months.

Daily

Use only warm, soapy water and a soft cloth to perform the following cleaning steps:

- Clean scraper assembly. Open safety interlock cover (item 3, page 7) and, with both hands, remove roller scraper assembly.
- Clean top feeder and feeder rollers (item 1, page 7).
- Clean loading tray (item 4, page 7) and discharge tray (item 5, page 7).

As Required

Use only warm, soapy water and a soft cloth to perform the following cleaning steps:

- Clean all outside surfaces of moulder, including adjustment handles, adjustment scales, start and stop buttons, inlet slot, etc.

List of Parts (Part 1 of 5)

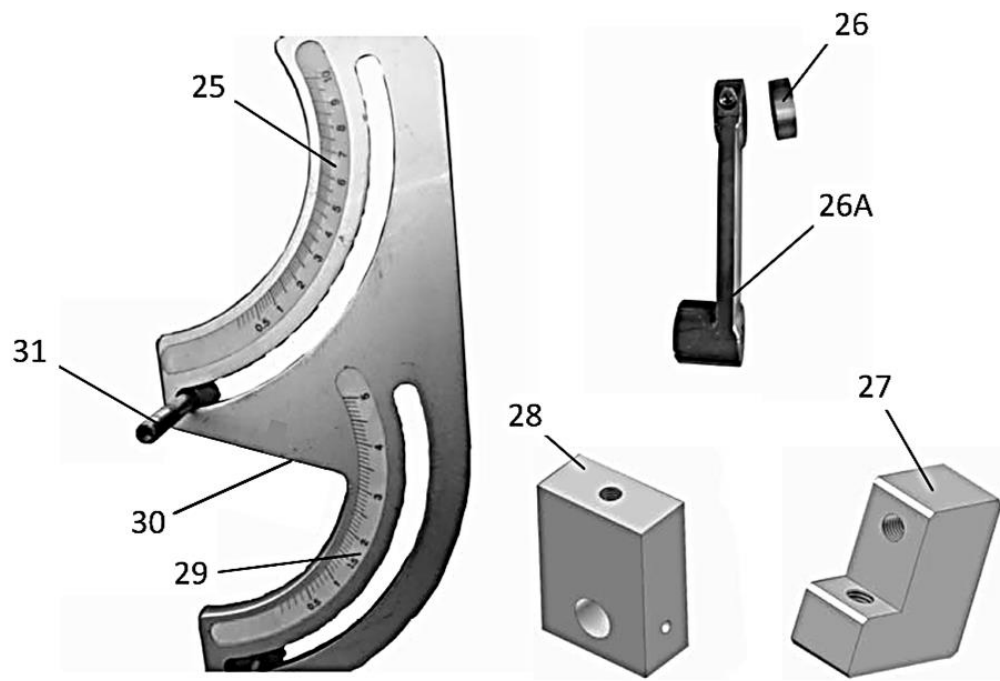
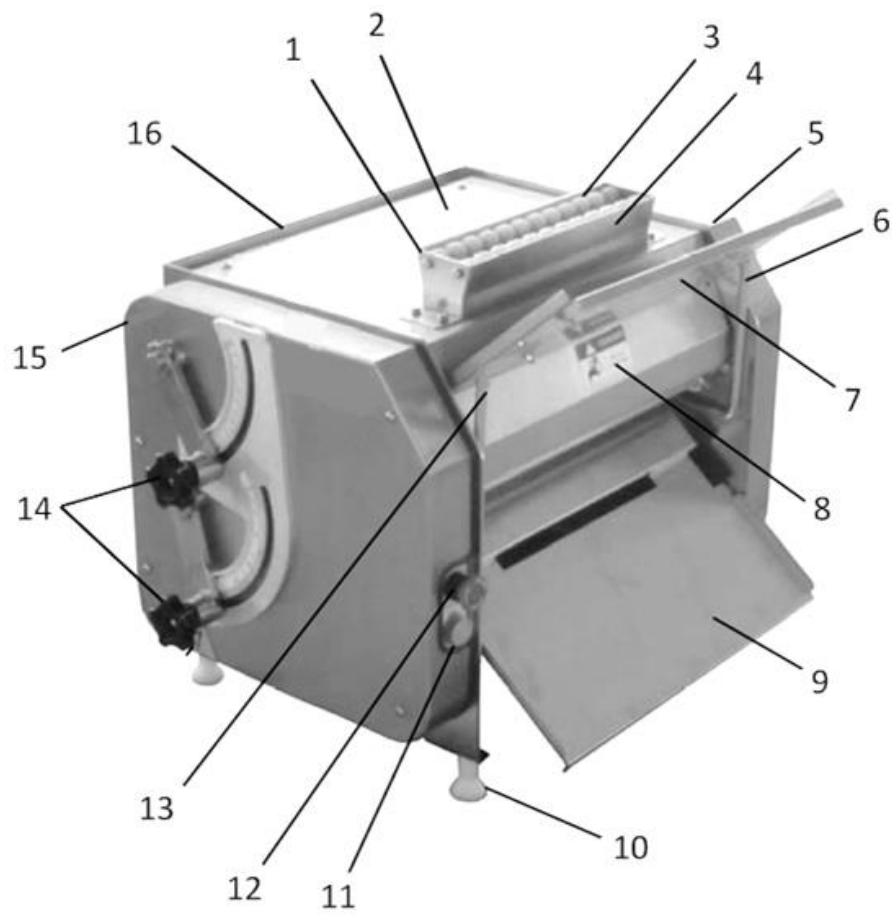

List of Parts (Part 2 of 5)

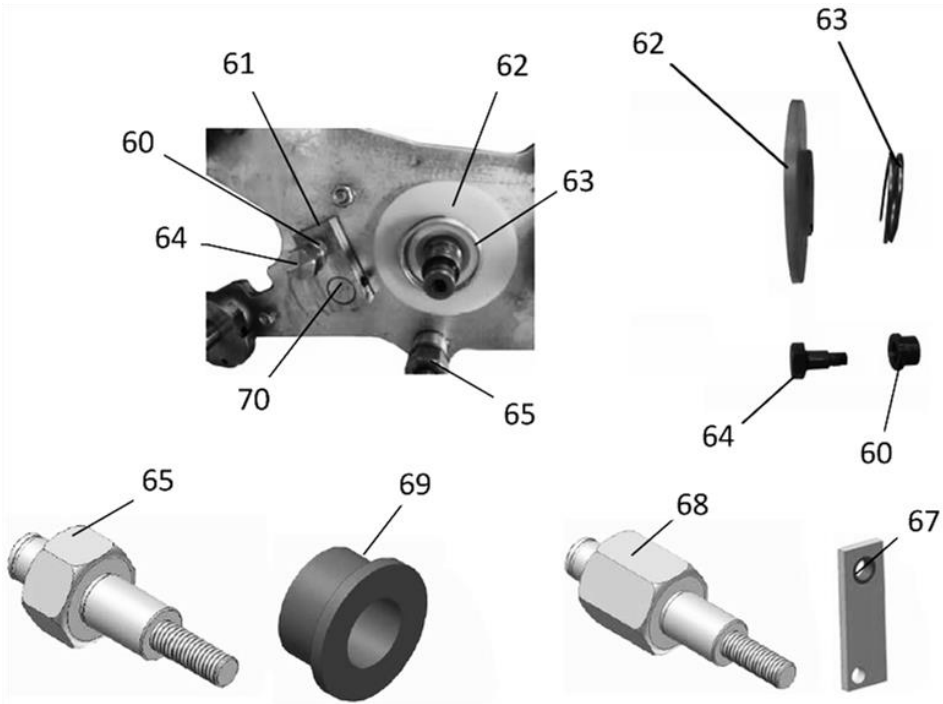
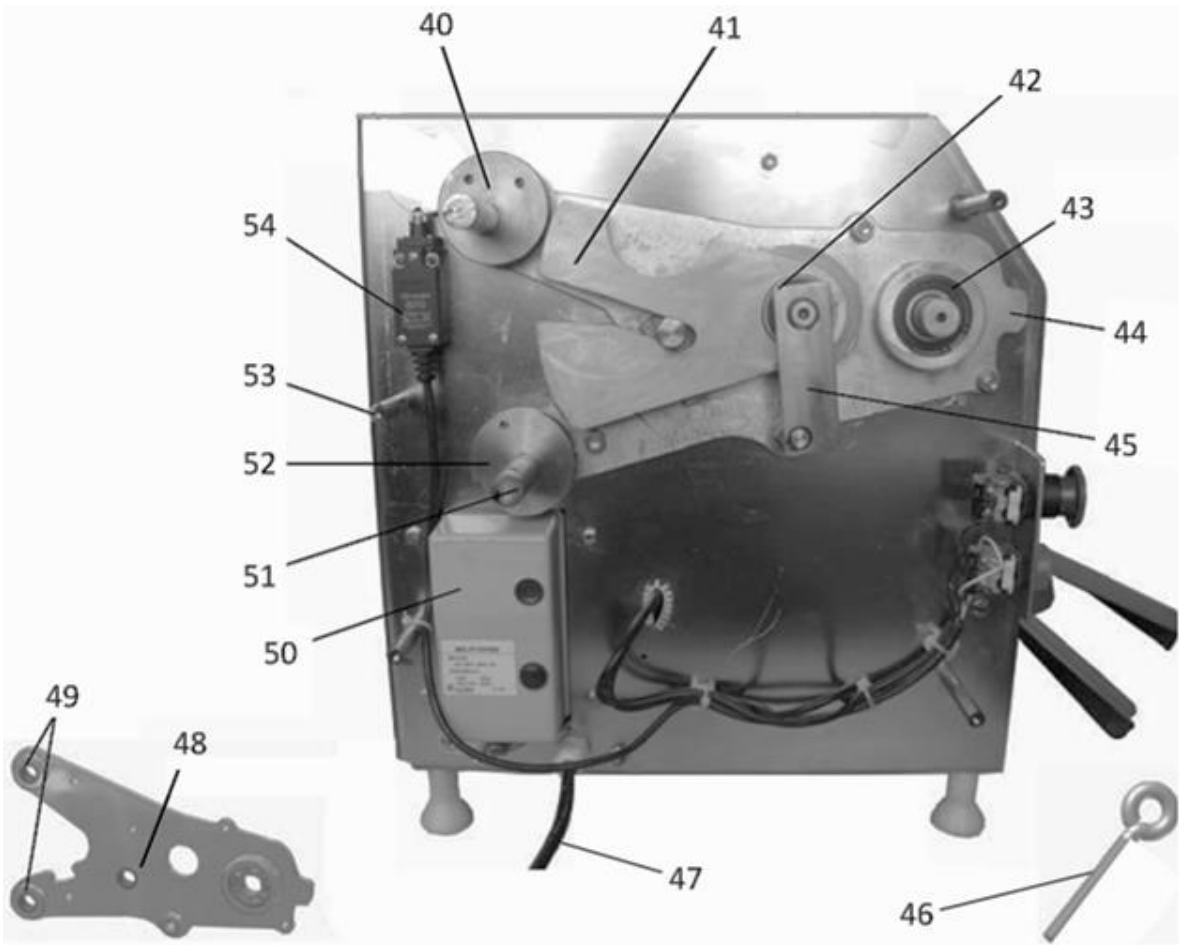

List of Parts (Part 3 of 5)

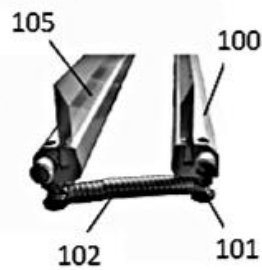
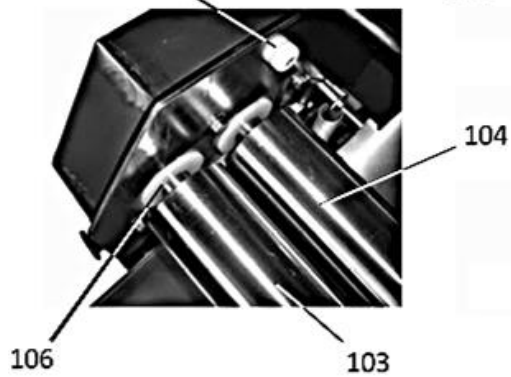
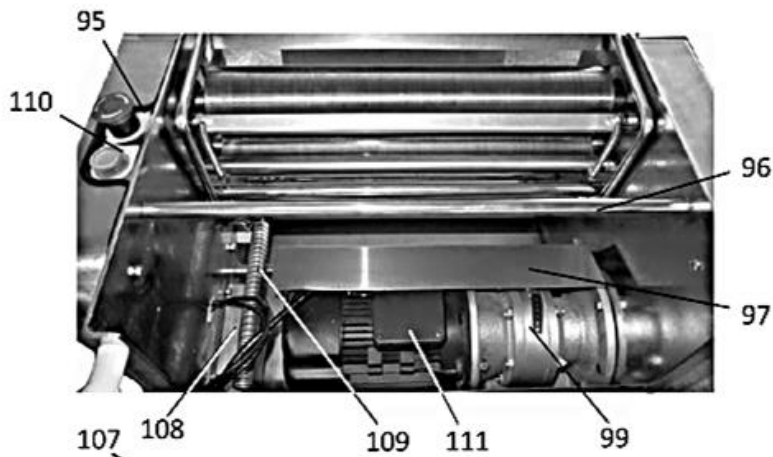
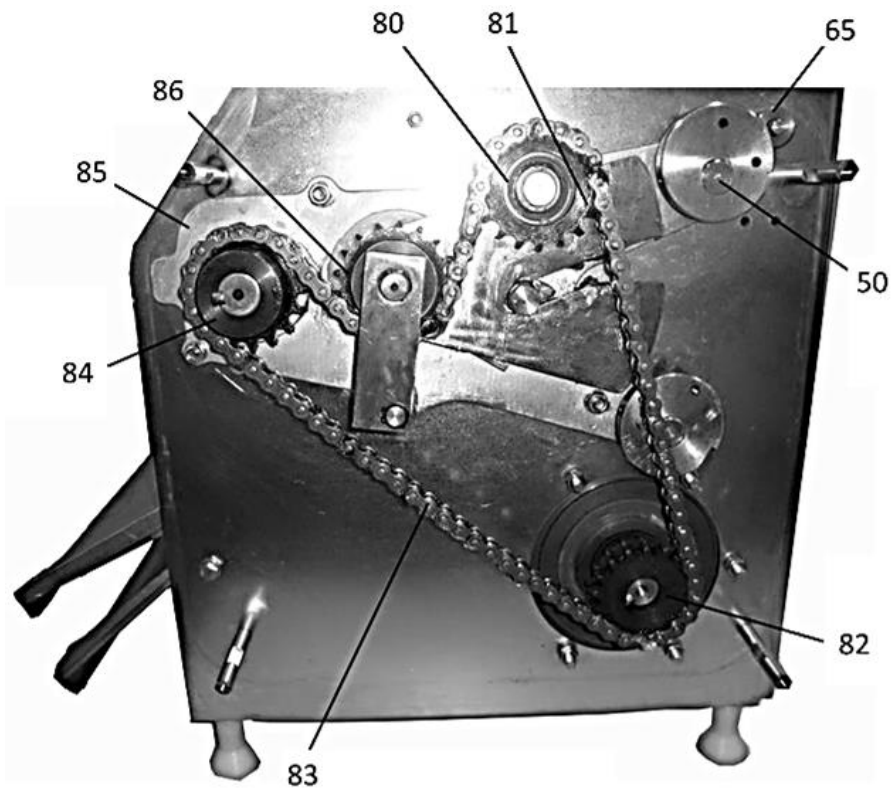

List of Parts (Part 4 of 5)

1	Roller Shaft	14SFPM50-70
2	Cover, Top	12SFPM50-85
3	Roller	14SFPM50-71
4	Chute, Inlet	11SFPM50-69
5	Cover, Right Side	11SFPM50-007
6	Bracket, Mounting – Left Side	11SFPM50-18
7	Tray, Loading	12SFPM50-04
8	Label, Warning	2TZLSFPM50-84
9	Tray, Discharge	12SFPM50-76
10	Foot	14SFPM50-79
11	Button, Stop/Start	16KGLAR22FOP10G
12	Button, Emergency Stop	16KGLAR22V2R01R
13	Bracket, Mounting – Left Side	11SFPM50-17
14	Knob	15BSLHY8314.31
15	Cover, Left Side	11SFPM50-006
16	Body	11SFPM50-0001
25	Label, Adjustable Arm - Upper	2TZLSFPM50-72
26A	Arm, Adjustable	12SFPM50-73
26	Pad, Adjustable Arm	14SFPM50-74
27	Seat, High Limit	14SFPM50-44
28	Holder, Cover	14SFPM50-52
29	Label, Adjustable Arm - Lower	2TZLSFPM50-60
30	Guide, Adjustable Arm	14SFPM50-66
31	Screw, Handle	14SFPM50-20
40	Disk	14SFPM50-34
41	Cam	14SFPM50-33
42	Bearing	15ZCLSFP50-2
43	Bearing	15ZCLSFP50-3
44	Base, Drive – Left Side	14SFPM50-54
45	Plate	14SFPM50-28
46	Ring Screw	14SFPM50-37
47	Cord, 110VAC	31110-25
48	Sleeve	14SFPM50-23
49	Sleeve	14SFPM50-22
50	Contactor	30700-05
51	Shaft	14SFPM50-21
52	Disk	14SFPM50-35
53	Support, Shaft	14SFPM50-45
54	Switch, Roller	16KGLMEA9112G

Schematic

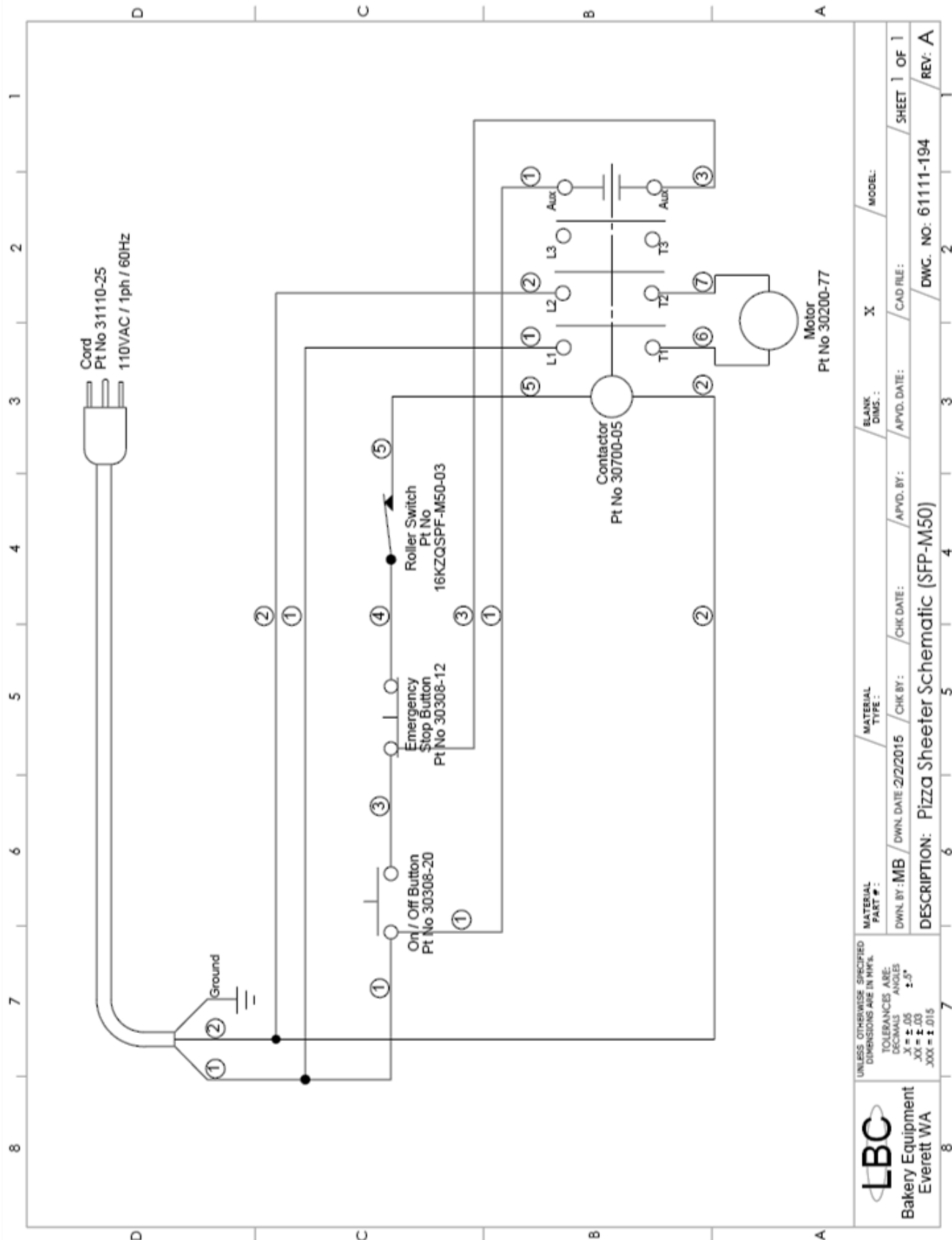

LBC Bakery Equipment Everett WA	UNLESS OTHERWISE SPECIFIED DIMENSIONS ARE IN INCH.		MATERIAL PART # :	BLANK DIMS. :	MODEL:
	DWN. BY: MB	DWN. DATE: 2/2/2015	CHK BY:	CHK DATE:	APVD. DATE:
TOLERANCES ARE: DECIMALS .XX ± .05 ANGLES ± .5° .XXX ± .015			DESCRIPTION: Pizza Sheeter Schematic (SFP-M50)		
			DWG. NO: 61111-194	SHEET 1 OF 1	REV: A



LIMITED WARRANTY

LBC Bakery Equipment ("LBC Equipment") has been skillfully manufactured, carefully inspected and packaged to meet rigid standards of excellence. LBC Bakery Equipment, Inc. (LBC) warrants products produced and sold by LBC and its duly authorized agents against defects in materials and workmanship within the following limitations:

What is Provided:

- Limited replacement parts as specified below, including standard ground shipping from LBC or service parts center when required.
- Limited labor for repair as specified below, including authorized service agent's transportation, portal to portal, up to one hundred (100) miles round trip and two (2) hours travel time.
- LBC, or an authorized service representative, will repair or replace, at LBC's sole discretion, any LBC equipment, including but not limited to the listed exclusions.

Coverage Period:

Extending from the date of shipment from LBC or its duly authorized dealer/distributor for the specified period:

- LRO and LMO Model Rack Ovens, LRP Model Rack Proofers, LRPR Model Retarder Proofers, LCR Model Rotisseries and LHC Model Holding Cabinets for a period of one (1) year limited parts and labor.
- Replacement parts shall be warranted for a period of ninety (90) days after installation by an authorized LBC service agent.

Conditions:

- Covered equipment must have been properly installed according to the requirements of the installation manual and all applicable local codes.
- The equipment shall not have been abused, misused or neglected or used for purposes other than intended by LBC.
- Water connected to the appliance shall have been in compliance with the following requirements:
 - Cold Water: 30 - 80 PSI
 - pH: 7 - 7.5
 - Conductivity: < 1/500,000 Ω per inch
 - Total Dissolved Solids: < 100 ppm
 - Hardness: 6.3 - 8.8 grains per gallon
 - Maximum Salinity and Ion content:
 - Chlorides: < 30 ppm
 - Sulfates: < 40 ppm
 - Iron: < 0.1 ppm
 - Copper: < 0.05 ppm
 - Manganese: < 0.05 ppm
- It is the responsibility of the purchaser to install and maintain the water supply to the appliance. Failure to provide satisfactory water quality in accordance with the operating manual requirements can cause damage to internal components and will VOID the warranty.
- All repair work is to be performed by an LBC authorized service agent.
- Equipment must be at the installation location of the original purchaser/user and shall not have been resold or reclaimed by another party.

Conditions (Continued):

- LBC equipment is for commercial use only. If sold as a component of another (OEM) manufacturer's equipment, or if used as a consumer product, such equipment is sold AS IS and without any warranty.
- Conditions of sale of the equipment shall have been met in full.
- The request for repair shall be made within the limited period of the warranty.
Failure to meet the above conditions will void this warranty.

Exclusions:

This warranty does not cover the following:

- Routine general maintenance, or periodic adjustment.
- Thermostat calibration after the first 30 days of use.
- Glass, Lamps, Gaskets, Oven Racks and other consumable parts.
- Air and gas burner adjustments.
- Fuse replacement.
- Cleaning and adjusting burners and pilot burners.
- Rack oven shutter adjustments.
- Repairs adjustments and corrections in the refrigeration portion of retarder/proofers resulting from the improper installation.
- Retightening of screws and fasteners.
- Failures caused by erratic or inadequate electrical, water, ventilation or gas service.
- Unauthorized repairs.
- Premature rusting, corrosion, or mineral build up caused by incoming water.
- Attached water treatment systems.
- Expedited freight on replacement parts other than standard ground shipments.
- Ordinary wear and tear.
- Use of the equipment for purposes other than those intended including non-commercial use such as residential or domestic.
- Appliances installed outside the contiguous U.S., including Alaska and Hawaii, and Canada.
- Incidental costs, charges, loss of business and damages as incurred by the user or others as a result of the use or failure of the equipment.
- Work and workmanship of the authorized service agent or others in the repair of the equipment.
- Other failures that are beyond the reasonable scope of this warranty.
- Damage caused during shipment is to be reported to the carrier, is not covered under this warranty, and is the sole responsibility of the purchaser/user.
- Natural disaster.

This warranty is exclusive and in lieu of all other warranties, expressed or implied, including expressed or implied warranties of merchantability or fitness for a particular purpose, each of which is hereby expressly disclaimed. The remedies described herein are exclusive and in no event shall LBC be liable for special, consequential or incidental damages for the breach or delay in the performance of this warranty