

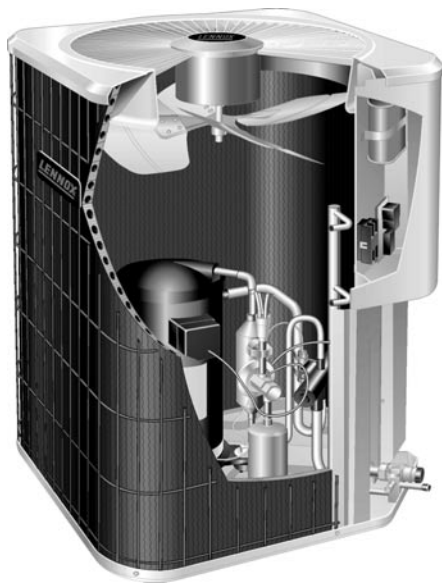

©2002 Lennox Industries Inc.
Dallas, Texas, USA



INSTALLATION INSTRUCTIONS

12HPB Series Units

HEAT PUMP UNITS
2 through 5 tons
504,532M
06/04
Supersedes 04/04

Technical
Publications
Litho U.S.A.

Table of Contents

12HPB Outdoor Units	1
Shipping & Packing List	1
General Information	1
Unit Dimensions	2
Setting the Unit	3
Electrical	4
Refrigerant Piping	6
Refrigerant Metering Device	10
Manifold Gauge Set	10
Service Valves	11
Leak Testing	12
Evacuation	13
Start-Up	13
Charging	14
System Operation	16
Defrost System	16
Maintenance	18
Optional Accessories	18
Start-Up and Performance Check List	18

RETAIN THESE INSTRUCTIONS FOR FUTURE REFERENCE

12HPB Outdoor Units

Lennox Merit® Series 12HPB outdoor units are approved and warranted only for installation with specially matched indoor coils, line sets, and refrigerant control devices as designated by Lennox. Refer to Lennox engineering handbook for expansion valve (TXV) kits which must be ordered separately.

Shipping and Packing List

- 1 - Assembled 12HPB outdoor unit

Check unit for shipping damage. Consult last carrier immediately if damage is found.

WARNING

Improper installation, adjustment, alteration, service or maintenance can cause property damage, personal injury or loss of life. Installation and service must be performed by a qualified installer or service agency.

IMPORTANT

The Clean Air Act of 1990 bans the intentional venting of refrigerant (CFC's and HCFC's) as of July 1, 1992. Approved methods of recovery, recycling or reclaiming must be followed. Fines and/or incarceration may be levied for noncompliance.

General Information

These instructions are intended as a general guide and do not supersede national or local codes in any way. Authorities having jurisdiction should be consulted before installation.

WARNING

This product and/or the indoor unit it is matched with may contain fiberglass wool.

Disturbing the insulation during installation, maintenance, or repair will expose you to fiberglass wool dust. Breathing this may cause lung cancer. (Fiberglass wool is known to the State of California to cause cancer.)

Fiberglass wool may also cause respiratory, skin, and eye irritation.

To reduce exposure to this substance or for further information, consult material safety data sheets available from address shown below, or contact your supervisor.

Lennox Industries Inc.
P.O. Box 799900
Dallas, TX 75379-9900



Unit Dimensions - inches (mm)

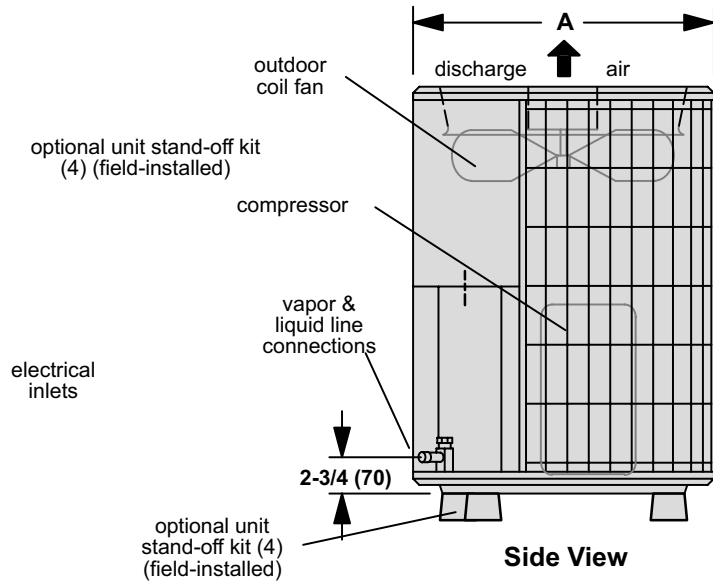
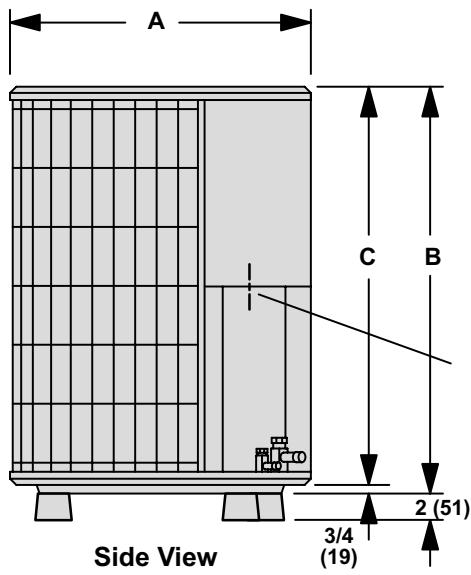
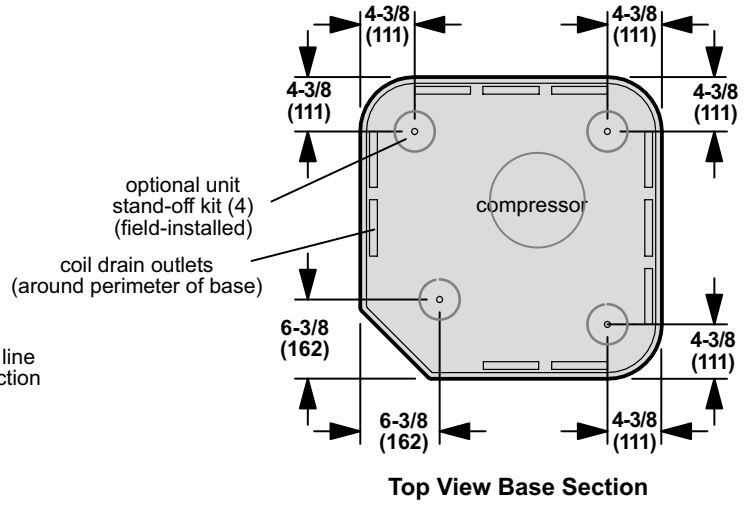
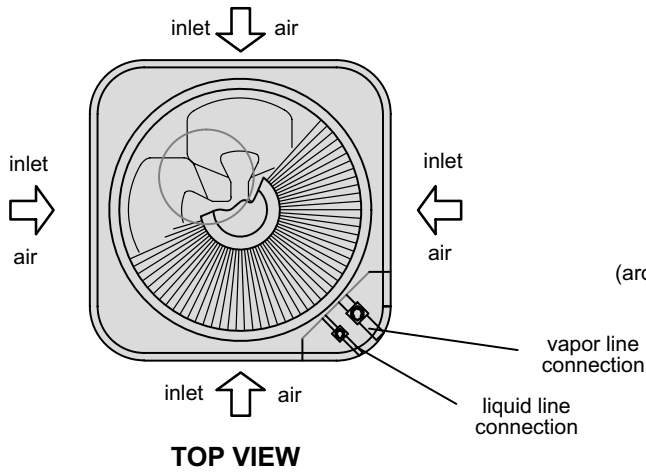

Model No.		A	B	C
12HPB24 - 12HPB30 12HPB36 - 12HPB42	in.	24-1/4	33-1/4	32-1/2
	mm	616	819	826
12HPB48 - 12HPB60	in.	28-1/4	37	36-1/4
	mm	718	940	921

Setting the Unit

⚠ CAUTION

In order to avoid injury, take proper precaution when lifting heavy objects.

⚠ CAUTION

Sharp sheet metal edges can cause injury. When installing the unit, avoid accidental contact with sharp edges.

Outdoor units operate under a wide range of weather conditions; therefore, several factors must be considered when positioning the outdoor unit. The unit must be positioned to give adequate clearances for sufficient airflow and servicing. A minimum clearance of 24 inches (610 mm) between multiple units must be maintained. Refer to figure 1 for installation clearances.

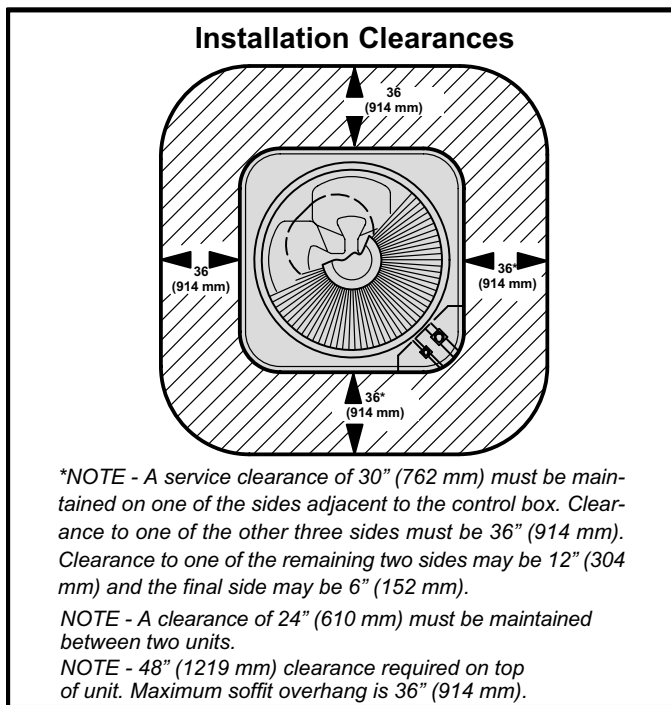

Figure 1

- 1 - Place a sound-absorbing material, such as Isomode, under the unit if it will be installed in a location or position that will transmit sound or vibration to the living area or adjacent buildings.
- 2 - Install the unit high enough above the ground or roof to allow adequate drainage of defrost water and prevent ice buildup.

- 3 - In heavy snow areas, do not locate the unit where drifting will occur. The unit base should be elevated above the depth of average snows.

NOTE - Elevation of the unit may be accomplished by constructing a frame using suitable materials. If a support frame is constructed, it must not block drain holes in unit base.

- 4 - When installed in areas where low ambient temperatures exist, locate unit so winter prevailing winds do not blow directly into outdoor coil.
- 5 - Locate unit away from overhanging roof lines which would allow water or ice to drop on, or in front of, coil or into unit.

Slab Mounting - Figure 2

When installing a unit at grade level, the top of the slab should be high enough above the grade so that water from higher ground will not collect around the unit. See figure 2. Slab should have a slope tolerance away from the building of 2 degrees or 2 inches per 5 feet (51 mm per 1524 mm). This will prevent ice from building up under the unit during a defrost cycle. Refer to the roof mounting section for barrier construction if the unit must face prevailing winter winds.

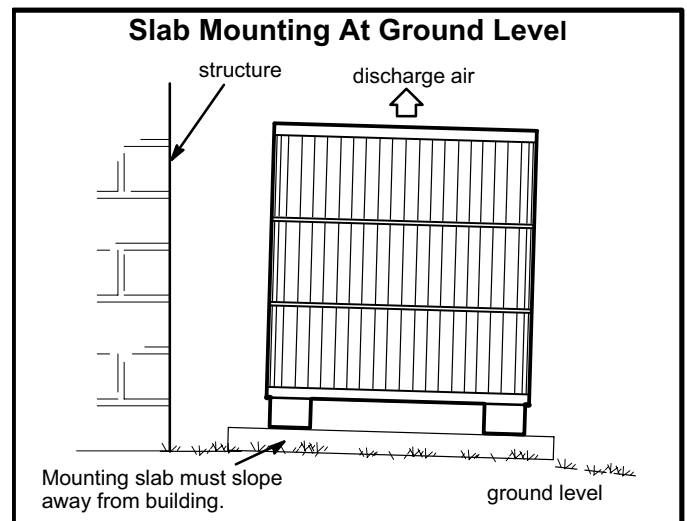

Figure 2

Roof Mounting - Figure 3

Install the unit a minimum of 6 inches (152 mm) above the roof surface to avoid ice build-up around the unit. Locate the unit above a load bearing wall or area of the roof that can adequately support the unit. Consult local codes for rooftop applications.

If unit coil cannot be mounted away from prevailing winter winds, a wind barrier should be constructed. Size the barrier at least the same height and width as outdoor unit. Mount barrier 24 inches (610 mm) from the sides of the unit in the direction of prevailing winds.

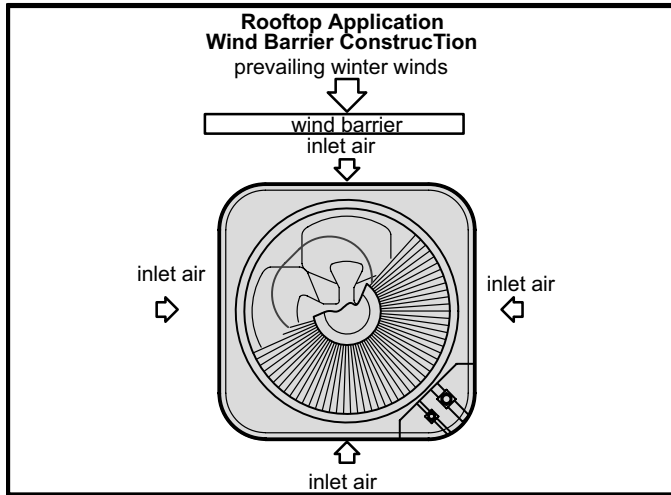

Figure 3

Electrical

In the U.S.A., wiring must conform with current local codes and the current National Electric Code (NEC). In Canada, wiring must conform with current local codes and the current Canadian Electrical Code (CEC).

Refer to the furnace or blower coil installation instructions for additional wiring application diagrams and refer to unit nameplate for minimum circuit ampacity and maximum overcurrent protection size.

⚠ WARNING

**Unit must be grounded in accordance with national and local codes.
Electric Shock Hazard.
Can cause injury or death.**

- 1 - Install line voltage power supply to unit from a properly sized disconnect switch.
- 2 - Ground unit at unit disconnect switch or to an earth ground.

NOTE - To facilitate conduit, a hole is in the bottom of the control box. Connect conduit to the control box using a proper conduit fitting.

NOTE - Units are approved for use only with copper conductors.

24V, Class II circuit connections are made in the low voltage junction box. Refer to figure 4 for field wiring diagram.

NOTE - A complete unit wiring diagram is located inside the unit control box cover.

- 3 - Install room thermostat (ordered separately) on an inside wall approximately in the center of the conditioned area and 5 feet (1.5 m) from the floor. It should not be installed on an outside wall or where it can be effected by sunlight, drafts or vibrations.
- 4 - Install low voltage wiring from outdoor to indoor unit and from thermostat to indoor unit. See figures 5 and 6.

Typical Wiring Field Wiring Diagram

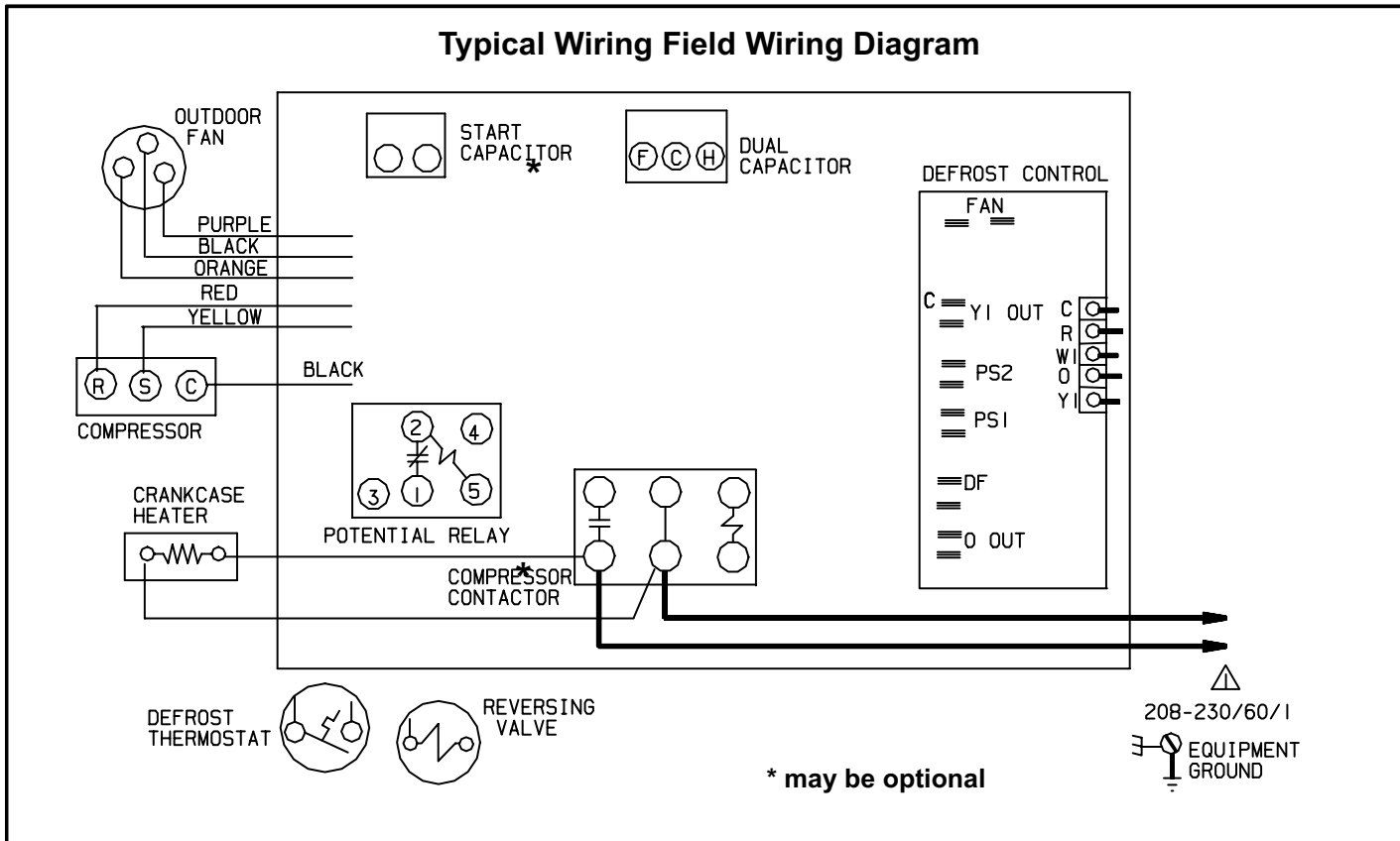

Figure 4

12HPB and Blower Unit Thermostat Designations

(Some connections may not apply.
Refer to specific thermostat and indoor unit.)

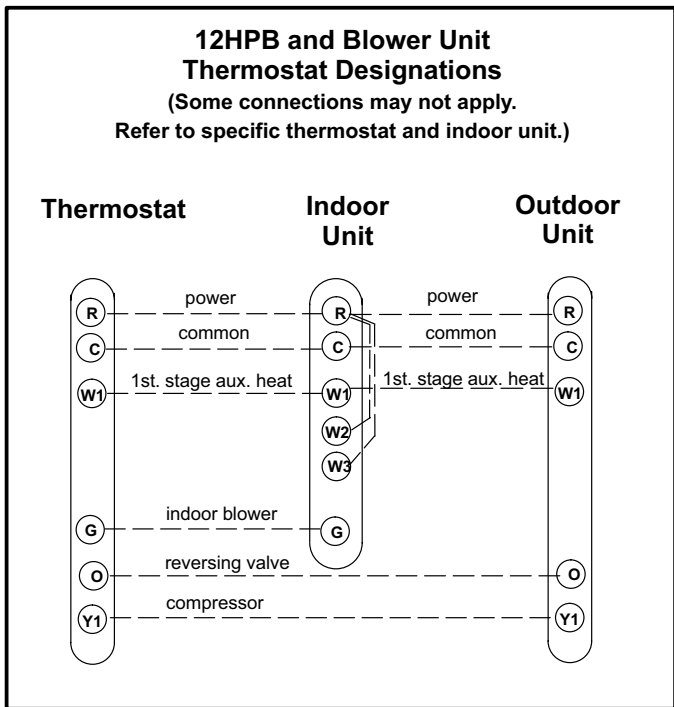

Figure 5

Outdoor Unit and Blower Unit Thermostat Designations (with emergency heat)

(Some connections may not apply.
Refer to specific thermostat and indoor unit.)

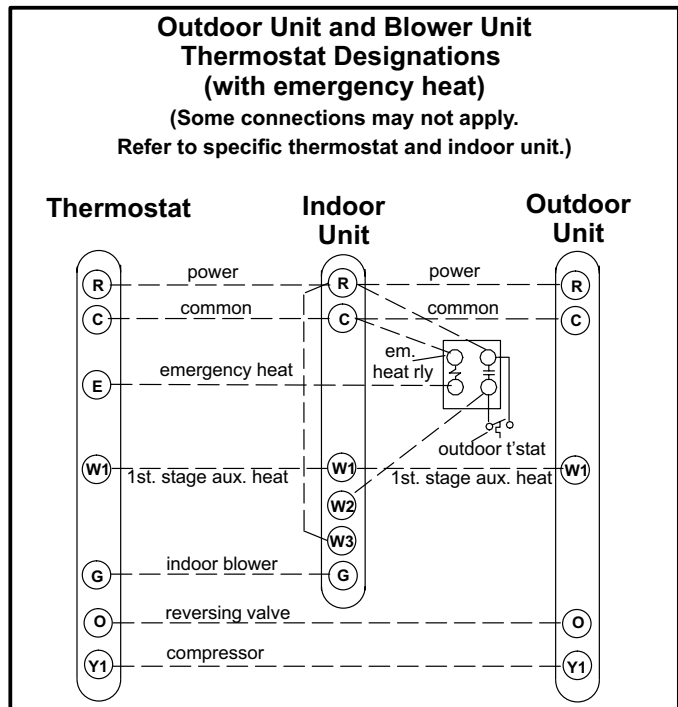

Figure 6

Refrigerant Piping

Field refrigerant piping consists of liquid and vapor lines from the outdoor unit (sweat connections) to the indoor coil (flare or sweat connections).

Use Lennox L15 (sweat, non-flare) series line sets as shown in table 1 or use field-fabricated refrigerant lines. Refer to Refrigerant Piping Guide (Corp. 9351-L9) for proper size, type, and application of field-fabricated lines. Valve sizes are also listed in table 1.

Table 1
Refrigerant Line Sets

Model	Valve Size Connections		Recommended Line Set		
	Liquid Line	Vapor Line*	Liquid Line	Vapor Line	L15 Line Sets
24 30	3/8" (9.5 mm)	3/4" (19 mm)	3/8" (9.5 mm)	3/4" (19 mm)	L15-41 15 ft. - 50 ft. (4.6 m - 15 m)
36 42 48	3/8" (9.5 mm)	7/8" (22.2 mm)	3/8" (9.5 mm)	7/8" (22.2 mm)	L15-65 15 ft. - 50 ft. (4.6 m - 15 m)
60	3/8" (9.5 mm)	1-1/8" (28.5 mm)	3/8" (9.5 mm)	1-1/8" (28.5 mm)	Field Fabricated

NOTE - Units are designed for line sets of up to fifty feet (15 m). For applications longer than fifty feet, consult the Lennox Refrigerant Piping Guide (Corp. 9351-L9). Select line

set diameters from table 1 to ensure that oil returns to the compressor.

Installing Refrigerant Line

During the installation of any heat pump or a/c system, it is important to properly isolate the refrigerant lines to prevent unnecessary vibration. Line set contact with the structure (wall, ceiling or floor) causes some objectionable noise when vibration is translated into sound. As a result, more energy or vibration can be expected. Closer attention to line set isolation must be observed.

Following are some points to consider when placing and installing a high-efficiency outdoor unit:

- 1- Placement** - Be aware some localities are adopting sound ordinances based on how noisy the unit is from the adjacent property not at the original installation. Install the unit as far as possible from the property line. When possible, do not install the unit directly outside a window. Glass has a very high level of sound transmission.
- 2- Line Set Isolation** - The following illustrations demonstrate procedures which ensure proper refrigerant line set isolation. Figure 7 shows how to install line sets on vertical runs. Figure 8 shows how to install line sets on horizontal runs. Figure 9 shows how to make a transition from horizontal to vertical. Finally, figure 10 shows how to place the outdoor unit and line set.

Installing Vertical Runs of Refrigerant Piping (new construction shown)

NOTE - Similar installation practices should be used if line set is to be installed on exterior of outside wall.

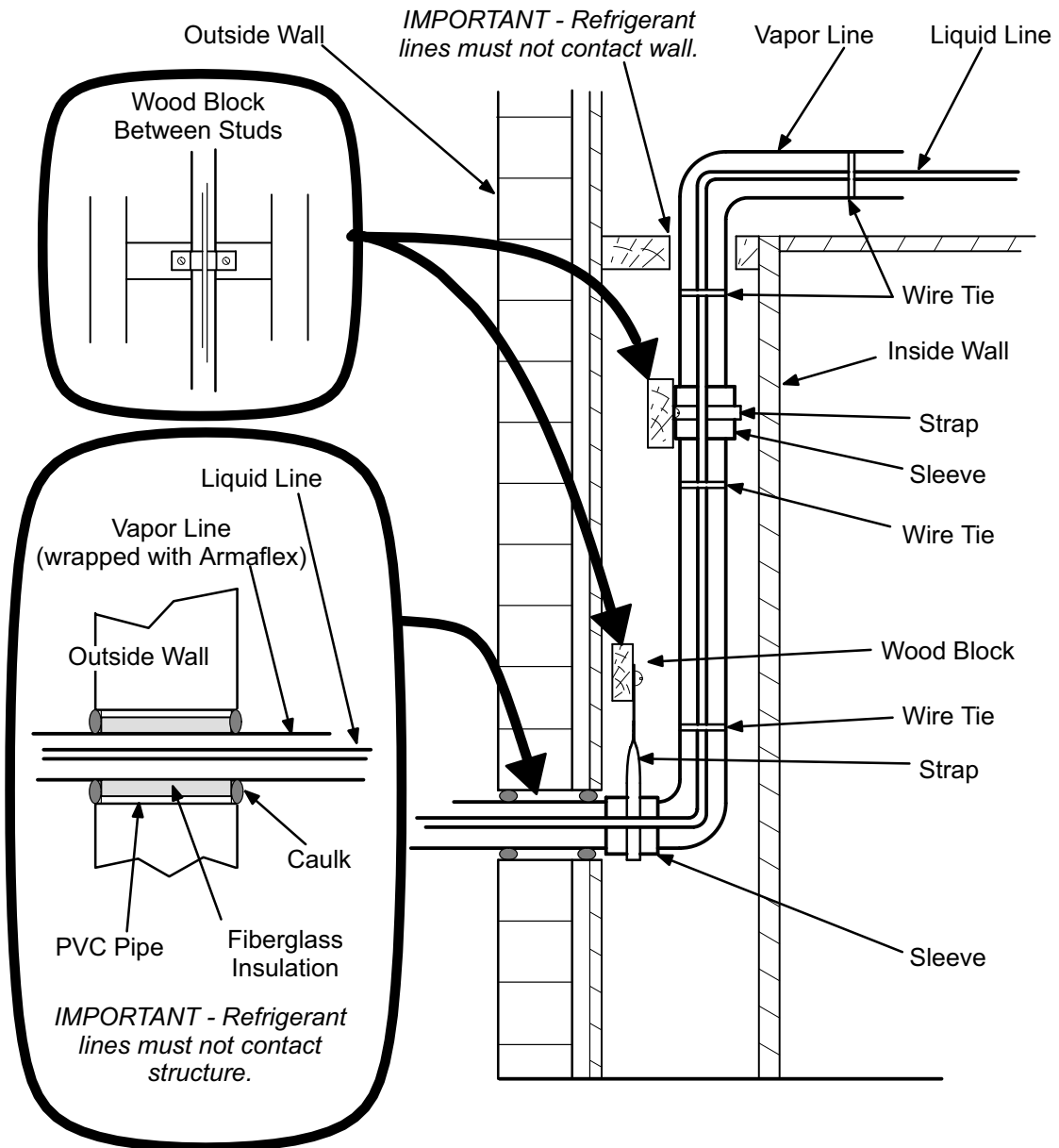

Figure 7

Installing Horizontal Runs of Refrigerant Piping

To hang line set from joist or rafter, use either metal strapping material or anchored heavy nylon wire ties.

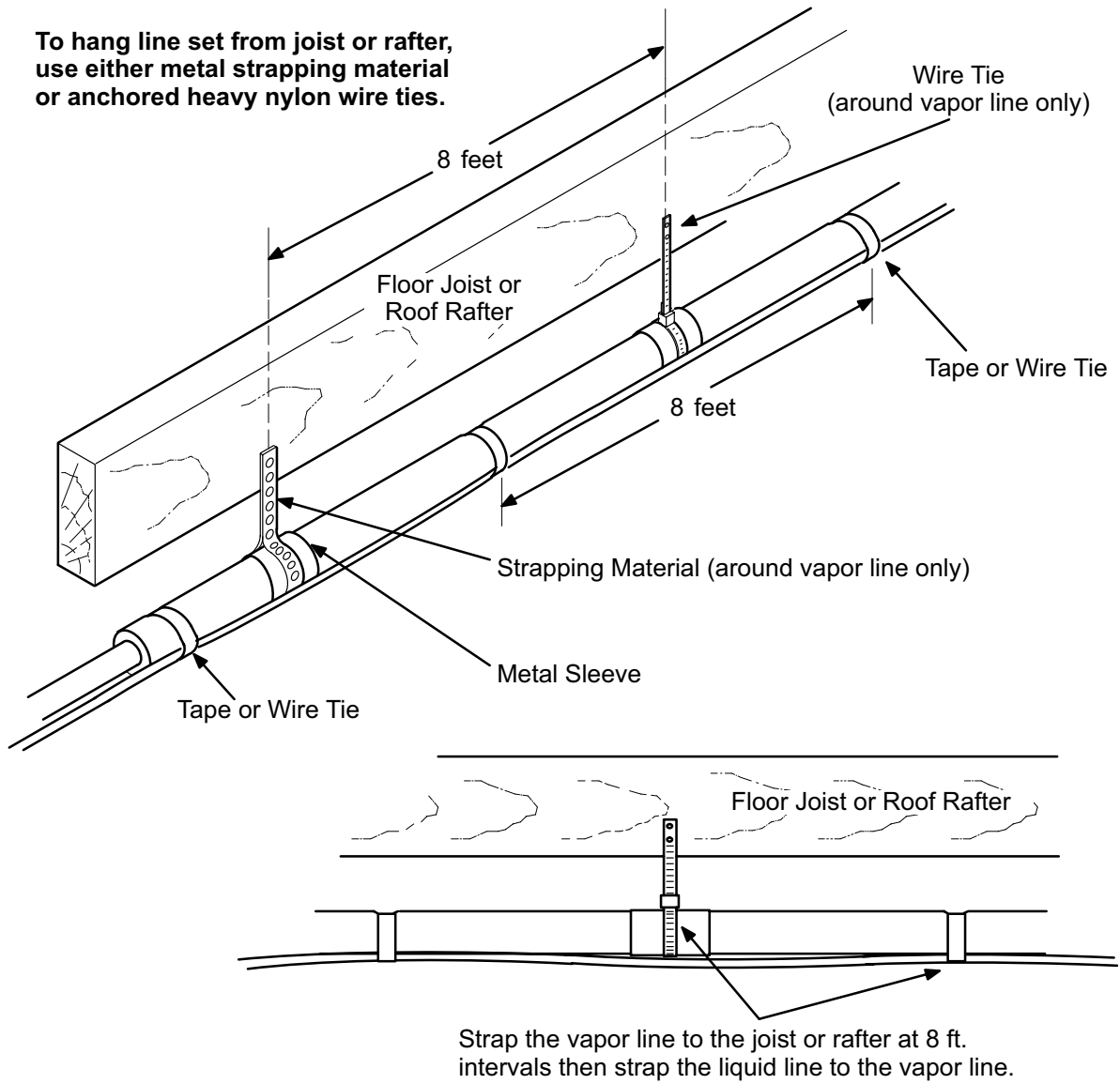

Figure 8

Transitioning From Vertical To Horizontal Runs of Refrigerant Piping

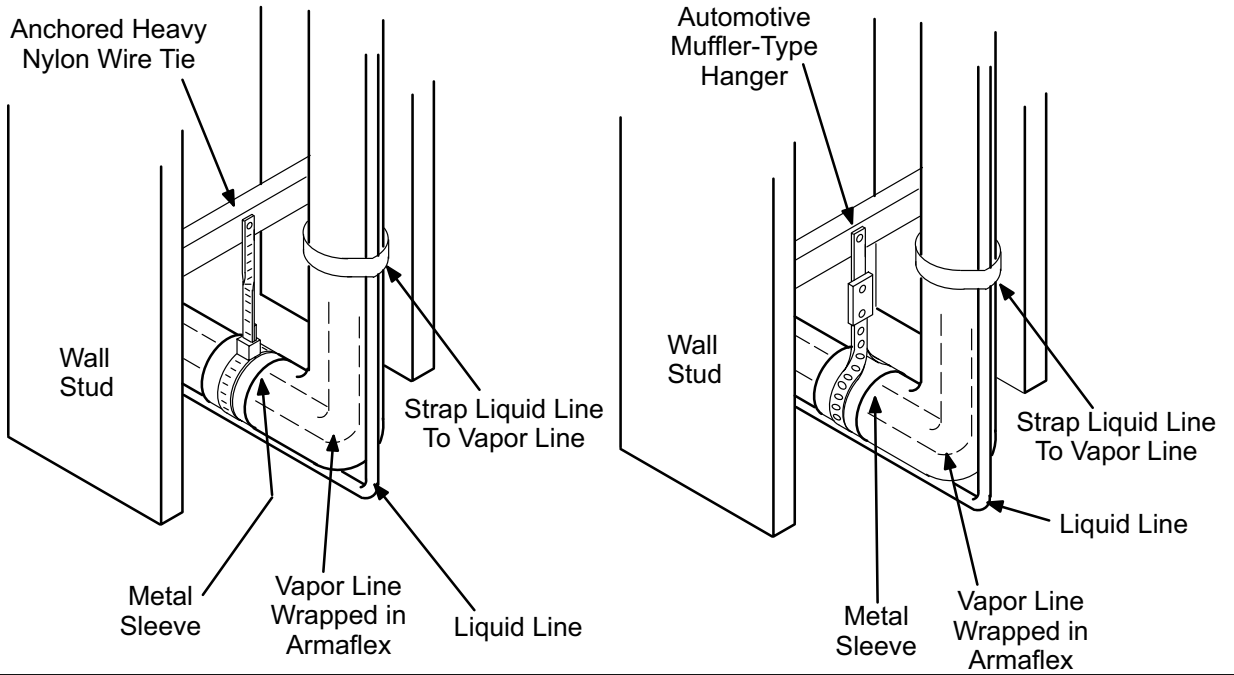

Figure 9

Outside Unit Placement and Installation

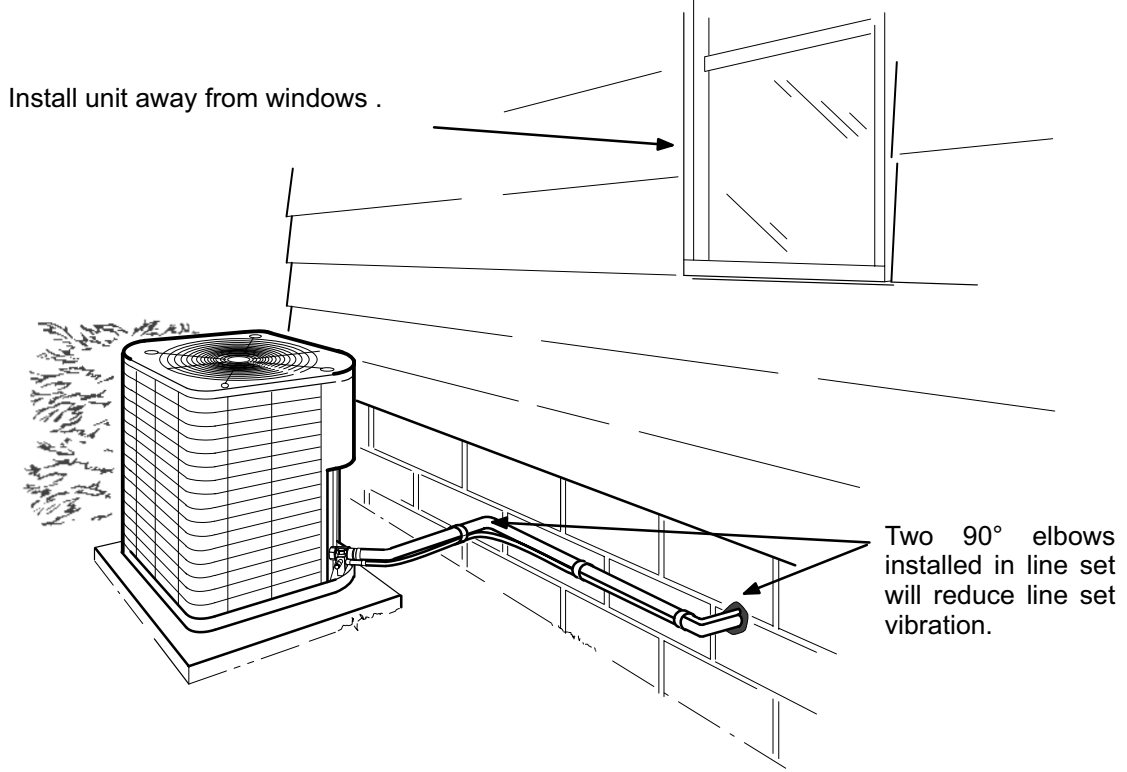

Figure 10

Brazing Connection Procedure

- 1 - Cut ends of the refrigerant lines square (free from nicks or dents). Debur the ends. The pipe must remain round, do not pinch end of the line.
- 2 - Before making line set connections, use dry nitrogen to purge the refrigerant piping. This will help to prevent oxidation and the introduction of moisture into the system.
- 3 - Use silver alloy brazing rods (5 or 6 percent minimum silver alloy for copper-to-copper brazing or 45 percent silver alloy for copper-to-brass or copper-to-steel brazing) which are rated for use with HCFC22 refrigerant. Wrap a wet cloth around the valve body and the copper tube stub. Braze the line set to the service valve.
- 4 - Wrap a wet cloth around the valve body and copper tube stub to protect it from heat damage during brazing. Wrap another wet cloth underneath the valve body to protect the base paint.
NOTE - The tube end must stay bottomed in the fitting during final assembly to ensure proper seating, sealing and rigidity.
- 5 - Install a field-provided thermal expansion valve (approved for use with HCFC22 refrigerant) in the liquid line at the indoor coil.

Refrigerant Metering Device

12HPB units are used in check expansion valve systems only. See the Lennox Engineering Handbook for approved TXV match-ups and application information.

Check expansion valves equipped with Chatleff fittings are available from Lennox. Refer to the Engineering Handbook for applicable check expansion valves for use with specific match-ups. See table 2 for applicable check expansion valve kits.

If you install a check expansion valve with an indoor coil that includes a fixed orifice, remove the orifice before the check expansion valve is installed.

⚠ IMPORTANT

Failure to remove RFC orifice when installing an expansion valve on the indoor coil will result in improper operation and damage to the system.

**Table 2
Indoor Check And Expansion Valve Kits**

Model	Kit Number
12HPB24 12HPB30 12HPB36	LB-85759F
12HPB42 12HPB48 12HPB60	LB-85759G

See figure 11 for installation of the check expansion valve.

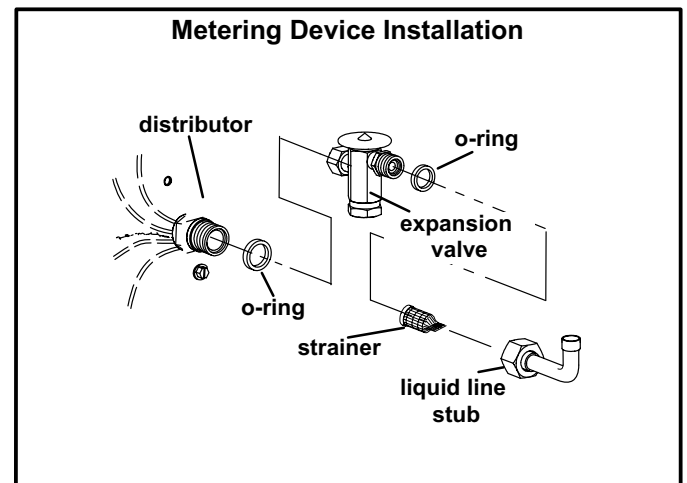

Figure 11

Manifold Gauge Set

When checking the unit charge, use a manifold gauge set that is equipped with "low loss" hoses. Do not use a manifold gauge set with anything other than a "low loss" hose. See figure 12 for manifold gauge connections.

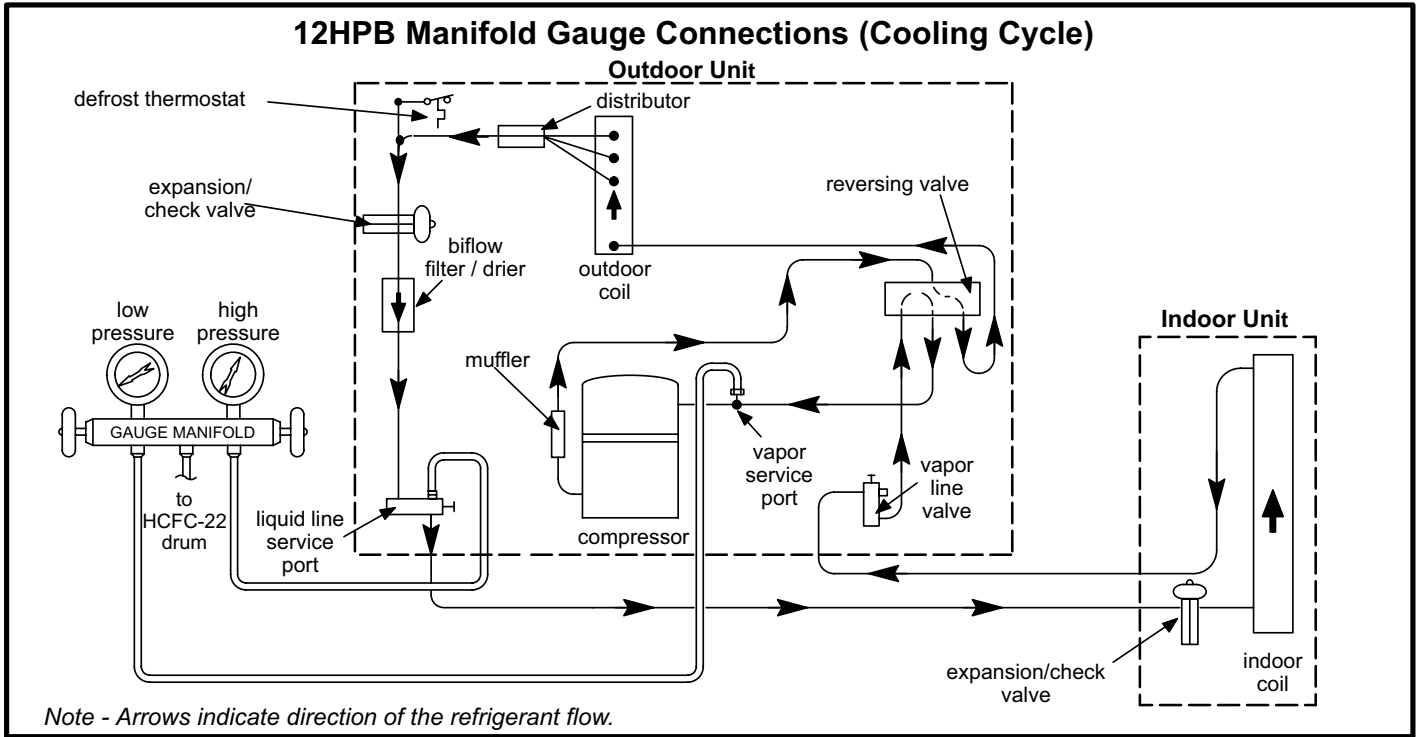

Figure 12

Service Valves

The liquid line and vapor line service valves (figures 13 and 14) and gauge ports are used for leak testing, evacuating, charging and checking charge. See table 3 for torque requirements.

Each valve is equipped with a service port which has a factory-installed Schrader valve. A service port cap protects the Schrader valve from contamination and serves as the primary leak seal.

**Table 3
Torque Requirements**

Part	Recommended Torque	
Service valve cap	8 ft.- lb.	11 NM
Sheet metal screws	16 in.- lb.	2 NM
Machine screws #10	28 in.- lb.	3 NM
Compressor bolts	90 in.- lb.	10 NM
Gauge port seal cap	8 ft.- lb.	11 NM

To Access Schrader Port:

- 1 - Remove service port cap with an adjustable wrench.
- 2 - Connect gauge to the service port.
- 3 - When testing is completed, replace service port cap. Tighten finger tight, then an additional 1/6 turn.

To Open Service Valve:

- 1 - Remove stem cap with an adjustable wrench.
- 2 - Use a service wrench with a hex head extension to back the stem out counterclockwise as far as it will go.
NOTE - Use a 3/16" hex head extension for liquid line sizes or a 5/16" extension for vapor line sizes.
- 3 - Replace stem cap. Tighten finger tight, then tighten an additional 1/6 turn.

To Close Service Valve:

- 1 - Remove stem cap with an adjustable wrench.
- 2 - Use a service wrench with a hex head extension to turn the stem clockwise to seat the valve. Tighten firmly.
NOTE - Use a 3/16" hex head extension for liquid line sizes or a 5/16" extension for vapor line sizes.
- 3 - Replace the stem cap. Tighten finger tight, then tighten an additional 1/6 turn.

Vapor Line (Ball-Type) Service Valve

Vapor line service valves function the same way as the other valves, the difference is in the construction. These valves are not rebuildable. If a valve has failed, you must replace it. A ball valve is illustrated in figure 14.

The ball valve is equipped with a service port with a factory-installed Schrader valve. A service port cap protects the Schrader valve from contamination and assures a leak-free seal.

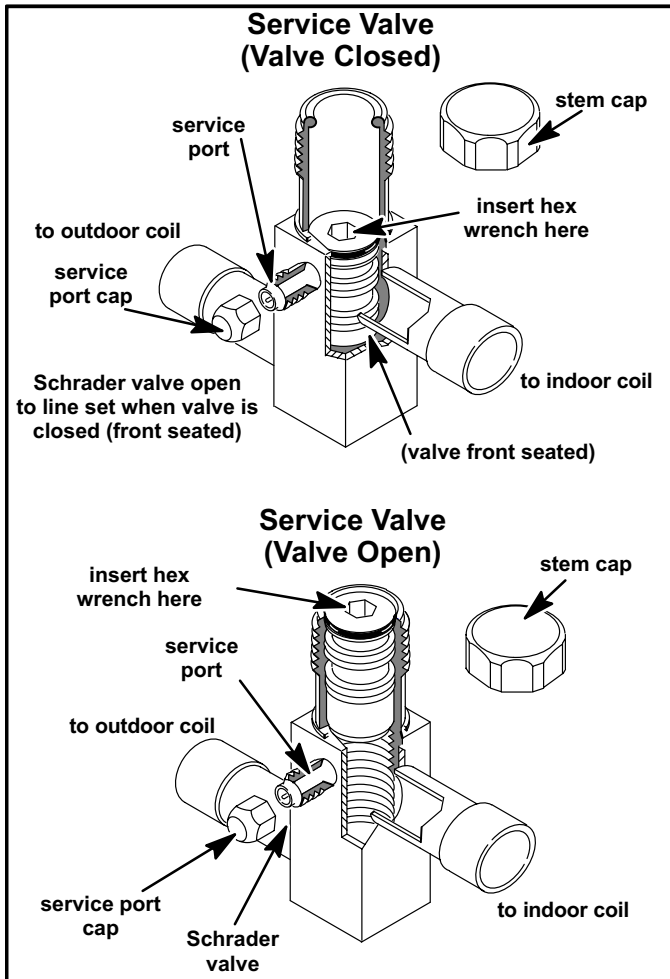

Figure 13

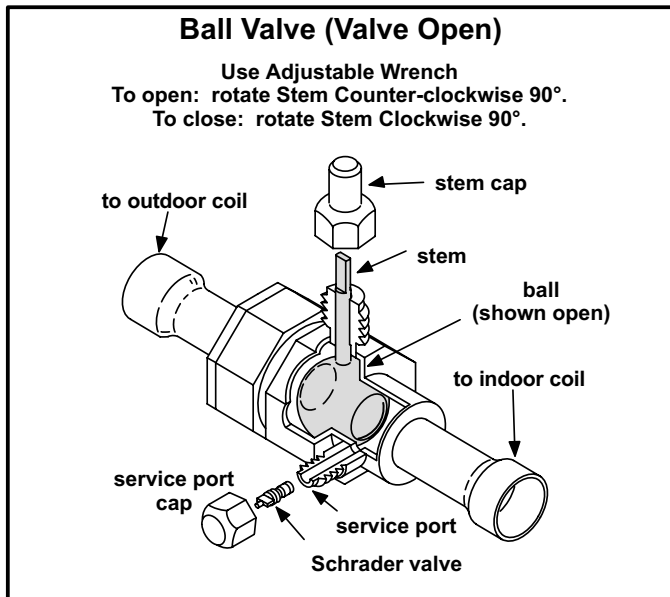

Figure 14

Leak Testing

After the line set has been connected to the indoor and outdoor units, check the line set connections and indoor unit for leaks.

⚠ WARNING



Danger of fire. Bleeding the refrigerant charge from only the high side may result in the low side shell and suction tubing being pressurized. Application of a brazing torch while pressurized may result in ignition of the refrigerant and oil mixture - check the high and low pressures before unbrazing.

⚠ WARNING

Refrigerant can be harmful if it is inhaled. Refrigerant must be used and recovered responsibly.

Failure to follow this warning may result in personal injury or death.

⚠ WARNING



Danger of explosion: Can cause equipment damage, injury or death. Never use oxygen to pressurize a refrigeration or air conditioning system. Oxygen will explode on contact with oil and could cause personal injury.

⚠ WARNING

Danger of explosion: Can cause equipment damage, injury or death. When using a high pressure gas such as dry nitrogen to pressurize a refrigeration or air conditioning system, use a regulator that can control the pressure down to 1 or 2 psig (6.9 to 13.8 kPa).

Using an Electronic Leak Detector or Halide

- 1 - Connect a cylinder of HCFC-22 to the center port of the manifold gauge set.
- 2 - With both manifold valves closed, open the valve on the HCFC-22 cylinder (vapor only).
- 3 - Open the high pressure side of the manifold to allow the HCFC-22 into the line set and indoor unit. Weigh in a trace amount of HCFC-22. [A trace amount is a maximum of 2 ounces (57 g) or 3 pounds (31 kPa) pressure.] Close the valve on the HCFC-22 cylinder and the valve on the high pressure side of the manifold gauge set. Disconnect the HCFC-22 cylinder.
- 4 - Connect a cylinder of nitrogen with a pressure regulating valve to the center port of the manifold gauge set.
- 5 - Connect the manifold gauge set high pressure hose to the vapor valve service port. (Normally, the high pressure hose is connected to the liquid line port; however, connecting it to the vapor port better protects the manifold gauge set from high pressure damage.)
- 6 - Adjust the nitrogen pressure to 150 psig (1034 kPa). Open the valve on the high side of the manifold gauge set which will pressurize line set and indoor unit.

- 7 - After a few minutes, open a refrigerant port to ensure the refrigerant you added is adequate to be detected. (Amounts of refrigerant will vary with line lengths.) Check all joints for leaks. Purge nitrogen and HCFC-22 mixture. Correct any leaks and recheck.

Evacuation

Evacuating the system of noncondensables is critical for proper operation of the unit. Noncondensables are defined as any gas that will not condense under temperatures and pressures present during operation of an air conditioning system. Noncondensables and water vapor combine with refrigerant to produce substances that corrode copper piping and compressor parts.

⚠ IMPORTANT

Use a thermocouple or thermistor electronic vacuum gauge that is calibrated in microns. Use an instrument that reads from 50 microns to at least 10,000 microns.

- 1 - Connect manifold gauge set to the service valve ports :
 - low pressure gauge to *vapor* line service valve
 - high pressure gauge to *liquid* line service valve
- 2 - Connect micron gauge.
- 3 - Connect the vacuum pump (with vacuum gauge) to the center port of the manifold gauge set.
- 4 - Open both manifold valves and start vacuum pump.
- 5 - Evacuate the line set and indoor unit to an **absolute pressure** of 23,000 microns (29.01 inches of mercury). During the early stages of evacuation, it is desirable to close the manifold gauge valve at least once to determine if there is a rapid rise in **absolute pressure**. A rapid rise in pressure indicates a relatively large leak. If this occurs, repeat the leak testing procedure.

*NOTE - The term **absolute pressure** means the total actual pressure within a given volume or system, above the absolute zero of pressure. Absolute pressure in a vacuum is equal to atmospheric pressure minus vacuum pressure.*
- 6 - When the absolute pressure reaches 23,000 microns (29.01 inches of mercury), close the manifold gauge valves, turn off the vacuum pump and disconnect the manifold gauge center port hose from vacuum pump. Attach the manifold center port hose to a nitrogen cylinder with pressure regulator set to 150 psig (1034 kPa) and purge the hose. Open the manifold gauge valves to break the vacuum in the line set and indoor unit. Close the manifold gauge valves.

⚠ CAUTION

Danger of Equipment Damage. Avoid deep vacuum operation. Do not use compressors to evacuate a system. Extremely low vacuums can cause internal arcing and compressor failure. Damage caused by deep vacuum operation will void warranty.

- 7 - Shut off the nitrogen cylinder and remove the manifold gauge hose from the cylinder. Open the manifold gauge valves to release the nitrogen from the line set and indoor unit.
- 8 - Reconnect the manifold gauge to the vacuum pump, turn the pump on, and continue to evacuate the line set and indoor unit until the absolute pressure does not rise above 500 microns (29.9 inches of mercury) within a 20-minute period after shutting off the vacuum pump and closing the manifold gauge valves.
- 9 - When the absolute pressure requirement above has been met, disconnect the manifold hose from the vacuum pump and connect it to an upright cylinder of HCFC-22 refrigerant. Open the manifold gauge valves to break the vacuum from 1 to 2 psig positive pressure in the line set and indoor unit. Close manifold gauge valves and shut off the HCFC-22 cylinder and remove the manifold gauge set.

Start-Up

⚠ IMPORTANT

If unit is equipped with crankcase heater, it should be energized 24 hours before unit start-up to prevent compressor damage as a result of slugging.

- 1 - Rotate the fan to check for frozen bearings or binding.
- 2 - Inspect all factory- and field-installed wiring for loose connections.
- 3 - After evacuation is complete, open the liquid line and vapor line service valves to release the refrigerant charge (contained in outdoor unit) into the system.
- 4 - Replace the stem caps and secure finger tight, then tighten an additional one-sixth (1/6) of a turn.
- 5 - Check voltage supply at the disconnect switch. The voltage must be within the range listed on the unit's nameplate. If not, do not start the equipment until you

have consulted the power company and the voltage condition has been corrected.

6 - Set the thermostat for a cooling demand. Turn on power to the indoor blower and close the outdoor unit disconnect switch to start the unit.

7 - Recheck voltage while the unit is running. Power must be within range shown on the nameplate.

Charging

The unit is factory charged with the amount of HCFC-22 refrigerant indicated on the unit rating plate. This charge is based on a matching indoor coil and outdoor coil with a 15 foot (4.6 m) line set. For varying lengths of line set, refer to table 4 for refrigerant charge adjustment.

Table 4

Liquid Line Set Diameter	Oz. per 5 ft. (g per 1.5 m) adjust from 15 ft. (4.6 m) line set*
3/8 in. (9.5 mm)	3 ounce per 5 ft. (85g per 1.5 m)

*If line length is greater than 15 ft. (4.6 m), add this amount. If line length is less than 15 ft. (4.6 m), subtract this amount.

The outdoor unit should be charged during warm weather. However, applications arise in which charging must occur in the colder months. *The method of charging is determined by the unit's refrigerant metering device and the outdoor ambient temperature.*

Measure the liquid line temperature and the outdoor ambient temperature as outlined below:

- 1 - Close manifold gauge set valves. Connect the manifold gauge set to the service valves.
 - low pressure gauge to *vapor* valve service port
 - high pressure gauge to *liquid* valve service port

Connect the center manifold hose to an upright cylinder of HCFC-22.

- 2 - Set the room thermostat to call for heat. This will create the necessary load for properly charging the system in the cooling cycle.
- 3 - Use a digital thermometer to record the outdoor ambient temperature.
- 4 - When the heating demand has been satisfied, switch the thermostat to cooling mode with a set point of 68°F (20°C). When pressures have stabilized, use a digital thermometer to record the liquid line temperature.
- 5 - The outdoor temperature will determine which charging method to use. Proceed with the appropriate charging procedure.

Weighing in the Charge TXV Systems Outdoor Temp < 65°F (18°C)

If the system is void of refrigerant, or if the outdoor ambient temperature is cool, the refrigerant charge should be weighed into the unit. Do this after any leaks have been repaired.

- 1 - Recover the refrigerant from the unit.
- 2 - Conduct a leak check, then evacuate as previously outlined.
- 3 - Weigh in the unit nameplate charge.

If weighing facilities are not available or if you are charging the unit during warm weather, follow one of the other procedures outlined below.

Subcooling Method Outdoor Temp. < 65°F (18°C)

When the outdoor ambient temperature is below 65°F (18°C), use the subcooling method to charge the unit. It may be necessary to restrict the air flow through the outdoor coil to achieve pressures in the 200-250 psig (1379-1724 kPa) range. These higher pressures are necessary for checking the charge. Block equal sections of air intake panels and move obstructions sideways until the liquid pressure is in the 200-250 psig (1379-1724 kPa) range. See figure 15.

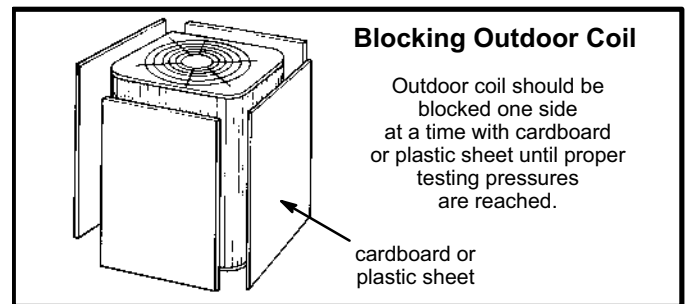

Figure 15

- 1 - With the manifold gauge hose still on the liquid service port and the unit's pressure stabilized, use a digital thermometer to record the liquid line temperature.
- 2 - At the same time, record the liquid line pressure reading.
- 3 - Use a temperature/pressure chart for HCFC-22 to determine the saturation temperature for the liquid line pressure reading.
- 4 - Subtract the liquid line temperature from the saturation temperature (according to the chart) to determine subcooling. (**Saturation temperature - Liquid line temperature = Subcooling**)
- 5 - Compare the subcooling value with those in table 5. If subcooling is greater than shown, recover some refrigerant. If subcooling is less than shown, add some refrigerant.

**Table 5
Subcooling Values**

Model	Subcooling Temp. °F (°C)
12HPB24	11 (6.1)
12HPB30	5 (2.8)
12HPB36	3 (1.7)
12HPB42	4 (2.2)
12HPB48	4 (2.2)
12HPB60	6 (3.3)

**Charging Using Normal Operating Pressures
and the Approach Method
Outdoor Temp. \geq 65°F (18°C)**

The following procedure is intended as a general guide and is for use on expansion valve systems only. For best results, indoor temperature should be 70°F (21°C) to 80°F (26°C). Monitor system pressures while charging.

- 1 - Record outdoor ambient temperature using a digital thermometer.
- 2 - Attach high pressure gauge set and operate unit for several minutes to allow system pressures to stabilize.
- 3 - Compare stabilized pressures with those provided in table 7, "Normal Operating Pressures." Minor variations in these pressures may be expected due to differences in installations. Significant differences could mean that the system is not properly charged or that a problem exists with some component in the system. Pressures higher than those listed indicate that the system is overcharged. Pressures lower than those listed indicate that the system is undercharged. Verify adjusted charge using the approach method.

Approach Method

- 4 - Use the same digital thermometer used to check outdoor ambient temperature to check liquid line temperature. Verify the unit charge using the approach method.
- 5 - The difference between the ambient and liquid temperatures should match values given in table 6. If the values don't agree with the those in table 6, add refrigerant to lower the approach temperature or recover refrigerant from the system to increase the approach temperature.

**Table 6
Approach Values**

Model	Liquid Temp. Minus Ambient Temp. °F (°C)
12HPB24	6 (3.3)
12HPB30	11 (6.1)
12HPB36	12 (6.7)
12HPB42	10 (5.6)
12HPB48	9 (5)
12HPB60	8 (4.4)

NOTE - For best results, the same thermometer should be used to check both outdoor ambient and liquid temperatures.

**Table 7
Normal Operating Pressures**

Outdoor Coil Air Entering Temp. °F (°C)	12HPB24		12HPB30		12HPB36		12HPB42		12HPB48		12HPB60	
	liq. +10 PSIG	vap. +5 PSIG	liq. +10 PSIG	vap. +5 PSIG	liq. +10 PSIG	vap. +5 PSIG	liq. +10 PSIG	vap. +5 PSIG	liq. +10 PSIG	vap. +5 PSIG	liq. +10 PSIG	vap. +5 PSIG
65 (18.3)	144	78	140	76	152	74	152	75	146	75	146	73
75 (23.9)	170	79	164	77	178	76	179	76	171	77	175	74
85 (29.4)	199	80	194	78	208	77	210	77	198	78	206	75
95 (35)	228	81	224	79	238	78	241	78	229	79	237	76
105 (40.6)	261	82	259	80	275	81	278	79	268	81	275	77

NOTE - Typical pressures only. Indoor evaporator match up, indoor air quantity, and evaporator load will cause the pressures to vary.

⚠ IMPORTANT

Use table 7 as a general guide when performing maintenance checks. This is not a procedure for charging the unit (Refer to Charging/Checking Charge section). Minor variations in these pressures may be expected due to differences in installations. Significant differences could mean that the system is not properly charged or that a problem exists with some component in the system.

System Operation

The outdoor unit and indoor blower cycle on demand from the room thermostat. When the thermostat blower switch is in the **ON** position, the indoor blower operates continuously.

Filter Drier

The unit is equipped with a biflow filter drier. See figure 12. If replacement is necessary, order another of like design.

Crankcase Heater

⚠ IMPORTANT

If unit is equipped with crankcase heater, it should be energized 24 hours before unit start-up to prevent compressor damage as a result of slugging.

Emergency Heat Function (Room Thermostat)

An emergency heat function is designed into some room thermostats. This feature is applicable when isolation of outdoor unit is required or when auxiliary electric heat is staged by outdoor thermostats. When the room thermostat is placed in the emergency heat position, the outdoor unit

control circuit is isolated from power and field-provided relays bypass the outdoor thermostats. An amber indicating light simultaneously comes on to remind the homeowner that he is operating in the emergency heat mode.

Emergency heat is usually used during an outdoor shutdown, but it should also be used following a power outage if power has been off for over an hour and the outdoor temperature is below 50°F (10°C). System should be left in the emergency heat mode at least six hours to allow the crankcase heater sufficient time to prevent compressor slugging.

Defrost System

The 12HPB defrost system includes two components: a defrost thermostat and a defrost control.

Defrost Thermostat

The defrost thermostat is located on the liquid line between the check/expansion valve and the distributor. When defrost thermostat senses 42°F (5.5°C) or cooler, the thermostat contacts close and send a signal to the defrost control board to start the defrost timing. It also terminates defrost when the liquid line warms up to 70°F (21°C).

Defrost Control

The defrost control board includes the combined functions of a time/temperature defrost control, defrost relay, diagnostic LEDs and terminal strip for field wiring connections. See figure 16.

The control provides automatic switching from normal heating operation to defrost mode and back. During compressor cycle (call for defrost), the control accumulates compressor run times at 30, 60, or 90 minute field-adjustable intervals. If the defrost thermostat is closed when the selected compressor run time interval ends, the defrost relay is energized and defrost begins.

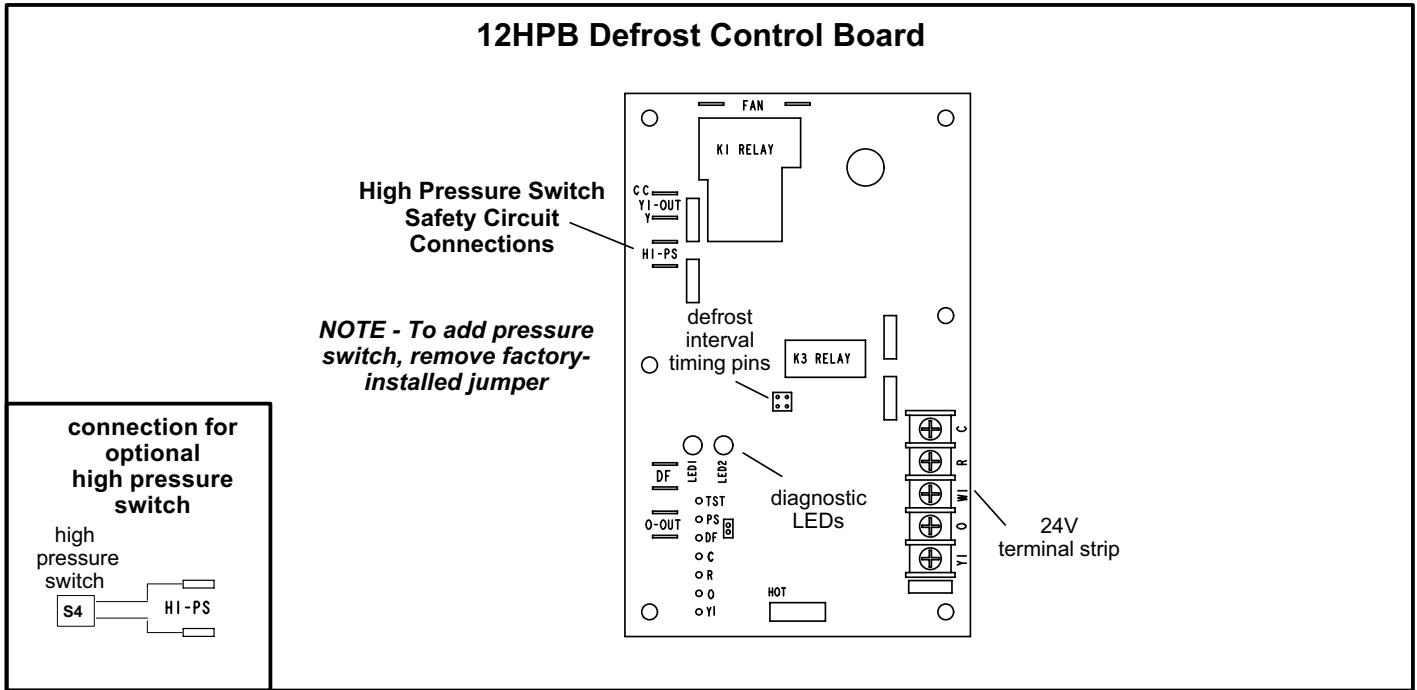

Figure 16

Defrost Control Timing Pins

Each timing pin selection provides a different accumulated compressor run time period during one thermostat run cycle. This time period must occur before a defrost cycle is initiated. The defrost interval can be adjusted to 30 (T1), 60 (T2), or 90 (T3) minutes. See figure 16. The defrost timing jumper is factory-installed to provide a 60-minute defrost interval. If the timing selector jumper is not in place, the control defaults to a 90-minute defrost interval. The maximum defrost period is 14 minutes and cannot be adjusted.

A TEST option is provided for troubleshooting. **The TEST mode may be started any time the unit is in the heating mode and the defrost thermostat is closed or jumpered.** If the jumper is in the TEST position at power-up, the control will ignore the test pins. When the jumper is placed across the TEST pins for two seconds, the control will enter the defrost mode. If the jumper is removed before an additional 5-second period has elapsed (7 seconds total), the unit will remain in defrost mode until the defrost thermostat opens or 14 minutes have passed. If the jumper is not removed until after the additional 5-second period has elapsed, the defrost will terminate and the test option will not function again until the jumper is removed and re-applied.

Pressure Switch Circuit

The defrost control incorporates a pressure switch circuit that allows the application of an optional high pressure switch. See figure 16. During a demand cycle, the defrost control will lock out the unit if the optional high pressure switch opens. The diagnostic LEDs will display a pattern for an open high pressure switch. See table 8. The unit will remain locked out until the switch resets or is reset.

Remove the factory-installed jumper before connecting the optional high pressure switch to the control board.

NOTE - If not using a pressure switch, the factory-installed jumper wire must be connected.

Diagnostic LEDs

The defrost board uses two LEDs for diagnostics. The LEDs flash a specific sequence according to the condition.

Table 8

Defrost Control Board Diagnostic LED		
Mode	LED 1	LED 2
Normal operation / power to board	Synchronized Flash with LED 2	Synchronized Flash with LED 1
Board failure or no power	Off	Off
Board failure	On	On
Pressure switch open	Flash	On

