

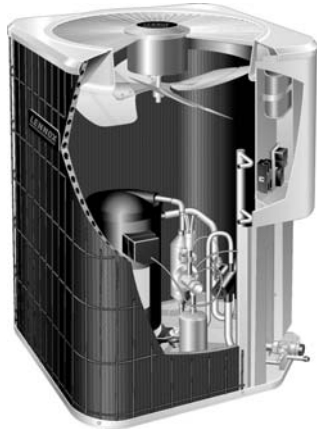

©2008 Lennox Industries Inc.
Dallas, Texas, USA



**RETAIN THESE INSTRUCTIONS
FOR FUTURE REFERENCE**

⚠ WARNING

Improper installation, adjustment, alteration, service or maintenance can cause personal injury, loss of life, or damage to property.

Installation and service must be performed by a licensed professional installer (or equivalent) or a service agency.

⚠ CAUTION

Physical contact with metal edges and corners while applying excessive force or rapid motion can result in personal injury. Be aware of, and use caution when working near these areas during installation or while servicing this equipment.

⚠ IMPORTANT

The Clean Air Act of 1990 bans the intentional venting of refrigerant (CFCs, HCFCs AND HFCs) as of July 1, 1992. Approved methods of recovery, recycling or reclaiming must be followed. Fines and/or incarceration may be levied for noncompliance.

INSTALLATION INSTRUCTIONS

Merit® Series 13ACD Units

AIR CONDITIONER UNITS
505,366M
01/08
Supersedes 11/07

TPD Technical
Publications
Litho U.S.A.

Table of Contents

Shipping and Packing List	1
13ACD Outdoor Unit	1
Unit Dimensions	2
General Information	2
Recovering Refrigerant from Existing System	4
Removing Existing Outdoor Unit	5
Positioning New Outdoor Unit	5
New or Replacement Line Set	6
Brazing Connections	8
Removing Indoor Unit Metering Device	9
Installing New Indoor Unit Metering Device	9
Testing for Leaks	11
Evacuating the System	12
Servicing Unit Delivered Void of Charge	13
Electrical Connections	13
Start-Up and Charging Procedures	14
System Operation	18
Maintenance	18
Homeowner Information	19
Start-Up and Performance Checklist	20

Shipping and Packing List

Check the unit for shipping damage and listed times below are intact. If damaged, or if parts are missing, immediately contact the last shipping carrier.

- 1 — Assembled outdoor unit
- 1 — Refrigerant flow control kit (Fixed Orifice)

13ACD Outdoor Unit

13ACD Air Conditioners, which will also be referred to in this instruction as the outdoor unit, uses HCFC-22 refrigerant. This outdoor unit must be installed with a matching indoor unit and line set as outlined in the *Lennox 13ACD Engineering Handbook*.

This outdoor unit is designed for use in systems that use one of the following refrigerant metering devices:

- Thermal expansion valve (TXV)
- Fixed orifice



Unit Dimensions - inches (mm)

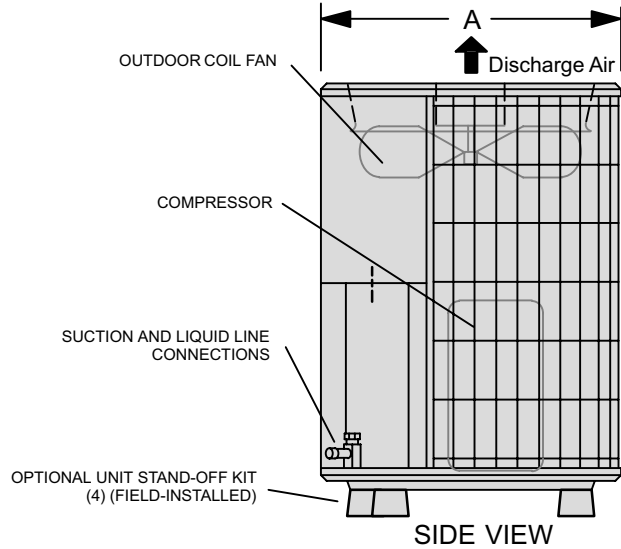
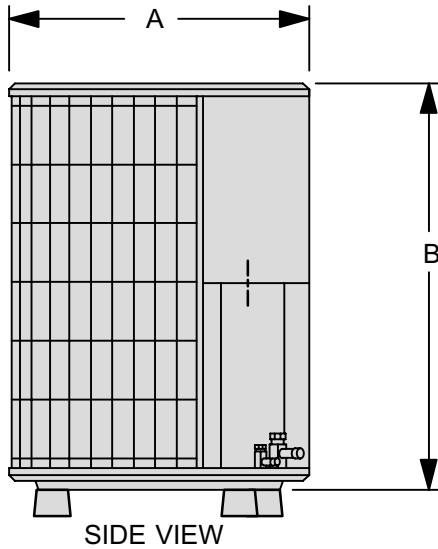

Model Number	A	B
13ACD-018	24-1/4 (616)	25-1/4 (641)
13ACD-024	24-1/4 (616)	25-1/4 (641)
13ACD-030	24-1/4 (616)	33-1/4 (845)
13ACD-036	24-1/4 (616)	33-1/4 (845)
13ACD-042	28-1/4 (718)	29-1/4 (743)
13ACD-048	28-1/4 (718)	37-1/4 (946)
13ACD-060	28-1/4 (718)	33-1/4 (845)

⚠ WARNING

This product and/or the indoor unit it is matched with may contain fiberglass wool.

Disturbing the insulation during installation, maintenance, or repair will expose you to fiberglass wool dust. Breathing this may cause lung cancer. (Fiberglass wool is known to the State of California to cause cancer.)

Fiberglass wool may also cause respiratory, skin, and eye irritation.

To reduce exposure to this substance or for further information, consult material safety data sheets available from address shown below, or contact your supervisor.

Lennox Industries Inc.
P.O. Box 799900
Dallas, TX 75379-9900

General Information

These instructions are intended as a general guide and do not supersede local codes in any way. Consult authorities who have jurisdiction before installation.

When servicing or repairing HVAC components, ensure caps and fasteners are appropriately tightened. Table 1 lists torque values for typical service and repair items.

Table 1. Torque Requirements

Part	Recommended Torque	
Service valve cap	8 ft.- lb.	11 NM
Sheet metal screws	16 in.- lb.	2 NM
Machine screws #10	28 in.- lb.	3 NM
Compressor bolts	90 in.- lb.	10 NM
Gauge port seal cap	8 ft.- lb.	11 NM

USING MANIFOLD GAUGE SETS

When checking the system charge, use a manifold gauge set that features low-loss anti-blow back fittings. See figure 1 for a typical manifold gauge connection setup.

OPERATING SERVICE VALVES

⚠ IMPORTANT

Only use Allen wrenches of sufficient hardness (50Rc - Rockwell Hardness Scale minimum). Fully insert the wrench into the valve stem recess.

Service valve stems are factory-torqued (from 9 ft-lbs for small valves, to 25 ft-lbs for large valves) to prevent refrigerant loss during shipping and handling. Using an Allen wrench rated at less than 50Rc risks rounding or breaking off the wrench, or stripping the valve stem recess.

The liquid and suction line service valves are typically used for removing refrigerant, flushing, leak testing, evacuating, checking charge and charging.

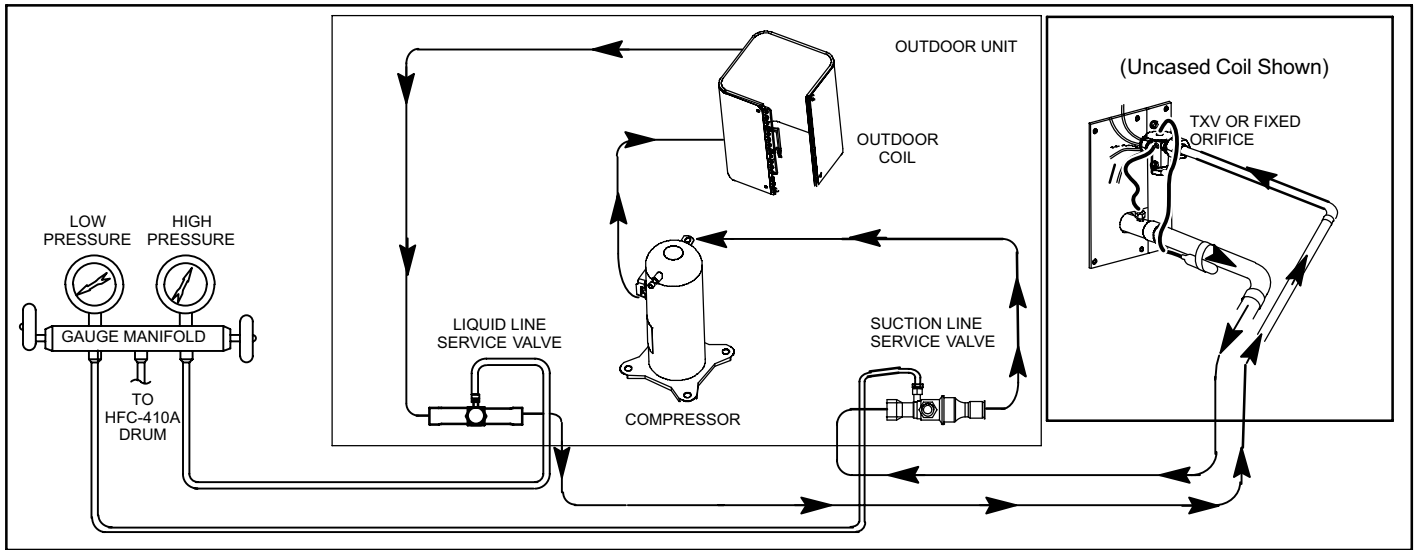

Figure 1. Typical Manifold Gauge Connection Setup

Each valve is equipped with a service port which has a factory-installed valve stem.

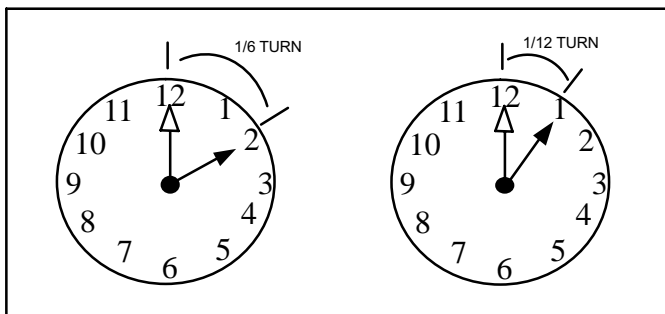

Figure 2. Cap Tightening Distances

⚠ IMPORTANT
To prevent stripping of the various caps used, the appropriately sized wrench should be used and fitted snugly over the cap before tightening.

Operating Angle-Type Service Valve

To Access Angle-Type Service Port:

A service port cap protects the service port core from contamination and serves as the primary leak seal.

1. Remove service port cap with an appropriately sized wrench.
2. Connect gauge to the service port.
3. When testing is completed, replace service port cap and tighten as follows:
 - *With Torque Wrench:* Finger tighten and then tighten per table 1.
 - *Without Torque Wrench:* Finger tighten and use an appropriately sized wrench to turn an additional 1/6 turn clockwise as illustrated in figure 2.

To Open and Close Angle-Type Service Valve:

A valve stem cap protects the valve stem from contamination and assures a leak-free seal.

1. Remove stem cap with an appropriately sized wrench.
2. Use a service wrench with a hex-head extension (3/16" for liquid-line valve sizes and 5/16" for suction-line valve sizes) to back the stem out counterclockwise as far as it will go.
3. Replace the stem cap and tighten as follows:
 - *With Torque Wrench:* Tighten finger tight and then tighten per table 1.
 - *Without Torque Wrench:* Finger tighten and use an appropriately sized wrench to turn an additional 1/12 turn clockwise as illustrated in figure 2.

NOTE - A label with specific torque requirements may be affixed to the stem cap. If the label is present, use the specified torque.

NOTE- To prevent stripping of the cap, the wrench should be appropriately sized and fit snugly over the cap before tightening the cap.

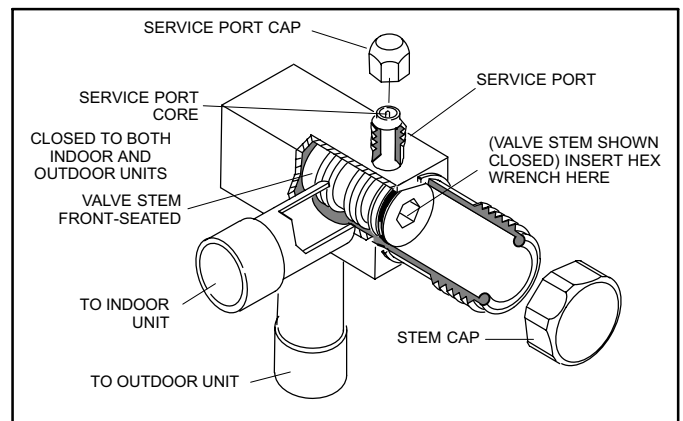

Figure 3. Angle-Type Service Valve (Font-Seated Closed)

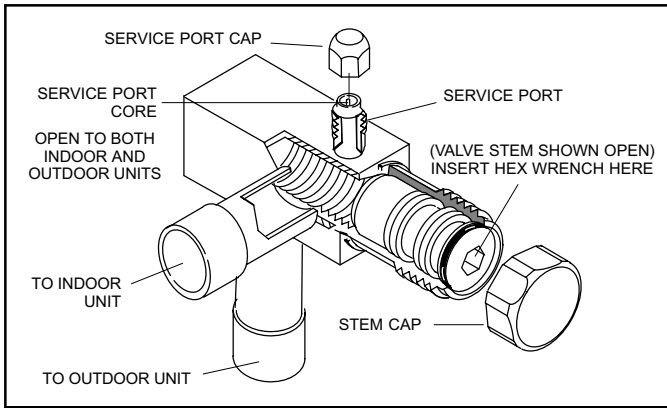

Figure 4. Angle-Type Service Valve (Back-Seated Opened)

Operating Ball-Type Service Valve

To Access Ball-Type Service Port:

A service port cap protects the service port core from contamination and serves as the primary leak seal.

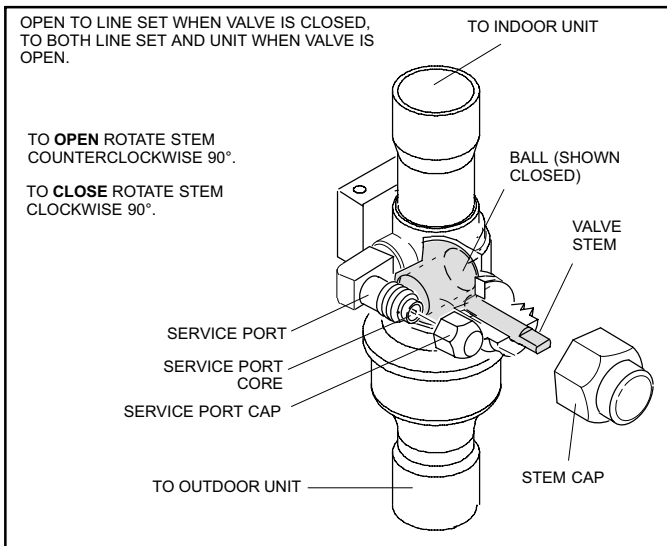

Figure 5. Ball-Type Service Valve

1. Remove service port cap with an appropriately sized wrench.
2. Connect gauge to the service port.
3. When testing is completed, replace service port cap and tighten as follows:
 - *With Torque Wrench:* Finger tighten and then tighten per table 1.
 - *Without Torque Wrench:* Finger tighten and use an appropriately sized wrench to turn an additional 1/6 turn clockwise as illustrated in figure 2.

To Open and Close Ball-Type Service Valve:

A valve stem cap protects the valve stem from contamination and assures a leak-free seal.

1. Remove stem cap with a wrench.
2. Use an appropriately sized wrench to open. To open valve, rotate stem counterclockwise 90°. To close rotate stem clockwise 90°.
3. Replace the stem cap and tighten as follows:
 - *With Torque Wrench:* Finger tighten and then tighten per table 1.
 - *Without Torque Wrench:* Finger tighten and use an appropriately sized wrench to turn an additional 1/12 turn clockwise as illustrated in figure 2.

NOTE - A label with specific torque requirements may be affixed to the stem cap. If the label is present, use the specified torque.

Recovering Refrigerant from Existing System

Remove existing HCFC-22 refrigerant using one of the following methods:

METHOD 1:

Use this method if the existing outdoor unit is not equipped with manual shut-off valves, and plan on using existing HCFC-22 refrigerant to flush the system.

NOTE - Use recovery machine instructions for specific setup requirements.

Perform the following task:

1. Disconnect all power to the existing outdoor unit.
2. Connect to the existing unit a gauge set, clean recovery cylinder and a recovery machine. Use the instructions provided with the recover machine on how to setup the connections.
3. Remove all HCFC-22 refrigerant from the existing system. Check gauges after shutdown to confirm that the entire system is completely void of refrigerant.

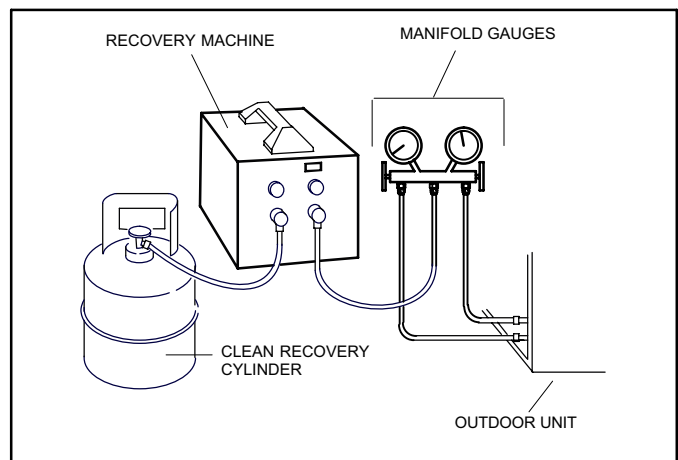

Figure 6. Typical Refrigerant Recovery (Method 1)

METHOD 2:

Use this method if the existing outdoor unit is equipped with manual shut-off valves, and plan on using new HCFC-22 refrigerant to flush the system.

IMPORTANT: Some system configurations may contain higher than normal refrigerant charge due to either large internal coil volumes, and/or long line sets. The following conditions may cause the compressor to stop functioning:

The following devices could prevent full system charge recovery into the outdoor unit:

- Outdoor unit's high or low-pressure switches if tripped can cycled the compressor **OFF**.
- Compressor can stop pumping due to tripped internal pressure relief valve.
- Compressor has internal vacuum protection that is designed to unload the scrolls (compressor stops pumping) when the pressure ratio meets a certain value or when the suction pressure is as high as 20 psig. (Compressor suction pressures should never be allowed to go into a vacuum. Prolonged operation at low suction pressures will result in overheating of the scrolls and permanent damage to the scroll tips, drive bearings and internal seals).

Once the compressor can not pump down to a lower pressure due to one of the above system conditions, shut off the suction valve. Turn OFF the main power to unit and use a recovery machine to recover any refrigerant left in the indoor coil and line set.

Perform the following task:

1. Start the existing HCFC-22 system in the cooling mode and close the liquid line valve.
2. Pump as much of the existing HCFC-22 refrigerant with the compressor back into the outdoor unit until you have reached the limitations of the outdoor system. Turn the outdoor unit main power **OFF** and use a recovery machine to remove the remaining refrigerant in the system.

NOTE - It may be necessary to bypass the low pressure switches if equipped to ensure complete refrigerant evacuation.

3. When the low side system pressures reach 0 psig, close the suction line valve.
4. Check gauges after shutdown to confirm that the valves are not allowing refrigerant to flow back into the low side of the system.

Removing Existing Outdoor Unit

Perform the following task at the existing outdoor unit:

- Disconnect line set at the service valves.
- Disconnect electrical service at the disconnect switch.
- Remove old outdoor unit.

Positioning New Outdoor Unit

See *Unit Dimensions* on page 2 to sizing mounting slab, platforms or supports. Refer to figure 7 for mandatory installation clearance requirements.

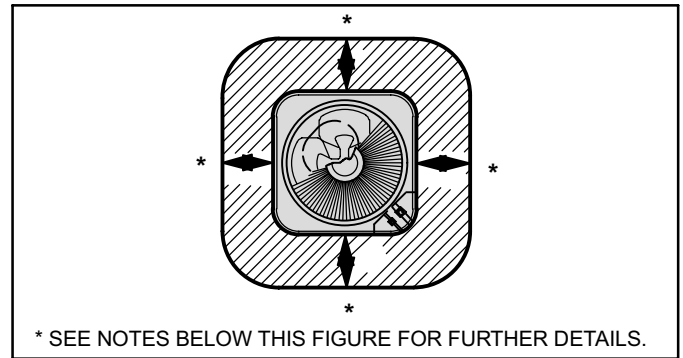

Figure 7. Installation Clearances

NOTES:

- Service clearance of 30 in. (762 mm) must be maintained on one of the sides adjacent to the control box.
- Clearance to one of the other three sides must be 36 in. (914 mm)
- Clearance to one of the remaining two sides may be 12 in. (305 mm) and the final side may be 6 in. (152 mm)
- 48 in. (1219 mm) clearance required on top of unit.
- A clearance of 24 in. (610 mm) must be maintained between two units

POSITIONING CONSIDERATIONS

CAUTION

In order to avoid injury, take proper precaution when lifting heavy objects.

Consider the following when positioning the unit:

- Some localities are adopting sound ordinances based on the unit's sound level registered from the adjacent property, not from the installation property. Install the unit as far as possible from the property line.
- When possible, do not install the unit directly outside a window. Glass has a very high level of sound transmission. For proper placement of unit in relation to a window see the provided illustration in figure 8.

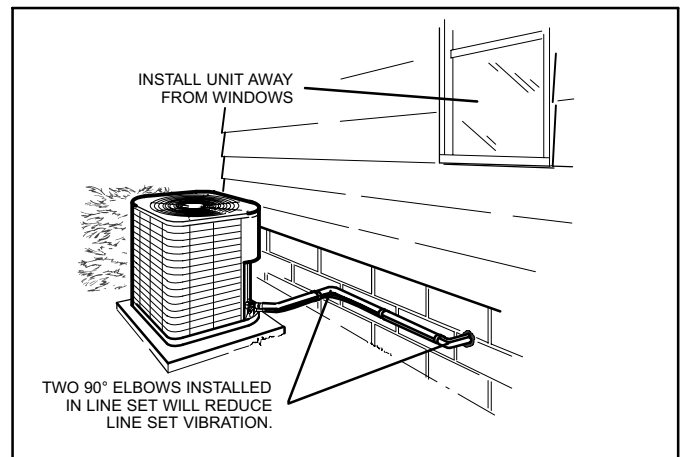

Figure 8. Outside Unit Placement

PLACING OUTDOOR UNIT ON SLAB

When installing a unit at grade level, the top of the slab should be high enough above the grade so that water from higher ground would not collect around the unit as illustrated in figure 9.

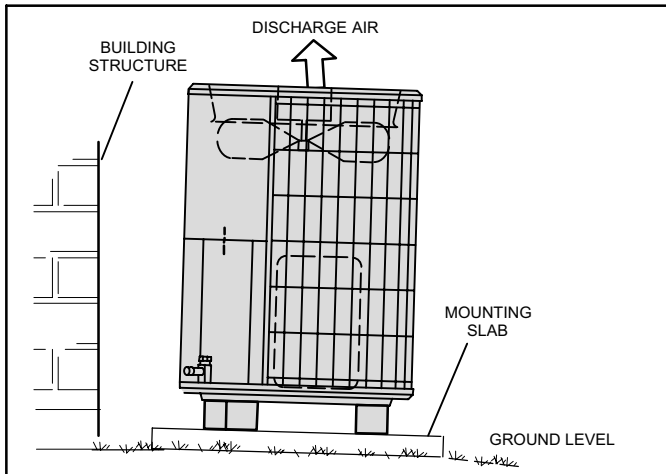

Figure 9. Ground Level Slab Mounting

Slab may be level or have a slope tolerance away from the building of not more than two degrees, or two inches per 5 feet (51 mm per 1524 mm) as illustrated in figure 9.

INSTALLING OUTDOOR UNIT ON ROOF

Install the unit a minimum of six inches (152 mm) above the roof surface to avoid ice build-up around the unit. Locate the unit above a load bearing wall or area of the roof that can adequately support the unit. Consult local codes for rooftop applications.

New or Replacement Line Set

This section provides information on new installation or replacement of existing line set. If a new or replacement line set is not required, then proceed to *Brazing Connections* on page 8.

If refrigerant lines are routed through a wall, seal and isolate the opening so vibration is not transmitted to the building. Pay close attention to line set isolation during installation of any HVAC system. When properly isolated from building structures (walls, ceilings, floors), the refrigerant lines will not create unnecessary vibration and subsequent sounds.

Also, consider the following when placing and installing a high-efficiency air conditioner:

REFRIGERANT LINE SET

Field refrigerant piping consists of liquid and suction lines from the outdoor unit (brazed connections) to the indoor unit coil (flare or brazed connections). Use Lennox L15 (brazed, non-flare) series line set, or use field-fabricated refrigerant lines as listed in table 2.

Table 2. Refrigerant Line Set

Model	Field Connections		Recommended Line Set		
	Liquid Line	Suction Line	Liquid Line	Suction Line	L15 Line Sets
-018 -024 -030	3/8 in. (10 mm)	3/4 in. (19 mm)	3/8 in. (10 mm)	3/4 in. (19 mm)	L15-41 15 ft. - 50 ft. (4.6 m - 15 m)
-036 -042 -048	3/8 in. (10 mm)	7/8 in. (22 mm)	3/8 in. (10 mm)	7/8 in. (22 mm)	L15-65 15 ft. - 50 ft. (4.6 m - 15 m)
-060	3/8 in. (10 mm)	1-1/8 in. (29 mm)	3/8 in. (10 mm)	1-1/8 in. (29 mm)	Field Fabricated

NOTE - When installing refrigerant lines longer than 50 feet, contact Lennox Technical Support Product Applications for assistance or Lennox piping manual. To obtain the correct information from Lennox, be sure to communicate the following points:

- Model (13ACD) and size of unit (e.g. -060).
- Line set diameters for the unit being installed as listed in table 2 and total length of installation.
- Number of elbows and if there is a rise or drop of the piping.

MATCHING WITH NEW OR EXISTING INDOOR COIL AND LINE SET

The RFC1-metering line consisted of a small bore copper line that ran from condenser to evaporator coil. Refrigerant was metered into the evaporator by utilizing temperature/pressure evaporation effects on refrigerant in the small RFC line. The length and bore of the RFC line corresponded to the size of cooling unit.

If the 13ACD is being used with either a new or existing indoor coil which is equipped with a liquid line which served as a metering device (RFC1), the liquid line must be replaced prior to the installation of the 13ACD unit. Typically a liquid line used to meter flow is 1/4" in diameter and copper.

LINE SET ISOLATION

This reference illustrates procedures, which ensure proper refrigerant line set isolation:

Line set for heat pump applications can not be installed underground. For more information see the *Lennox Refrigerant Piping Design and Fabrication Guidelines*, or contact Lennox Technical Support Product Applications for assistance.

- Installation of line set on horizontal runs is illustrated in figure 10.
- Installation of line set on vertical runs is illustrated in figure 11.
- Installation of a transition from horizontal to vertical is illustrated in figure 12.

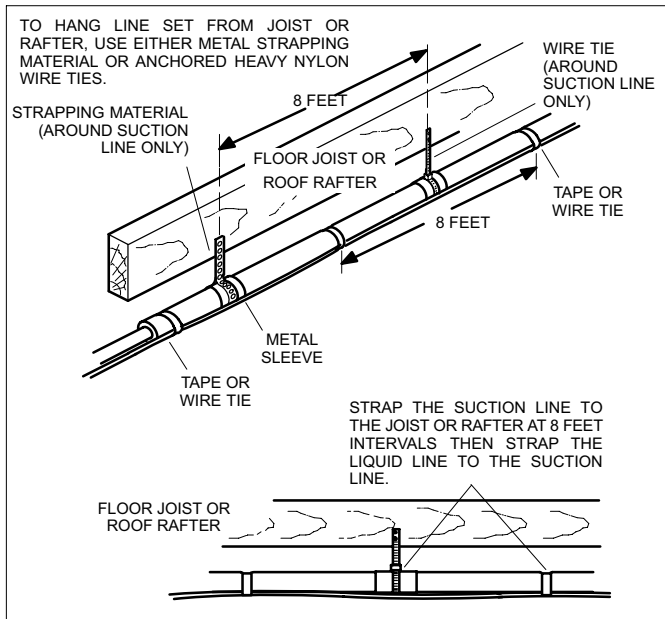

Figure 10. Refrigerant Line Set: Installing Horizontal Runs

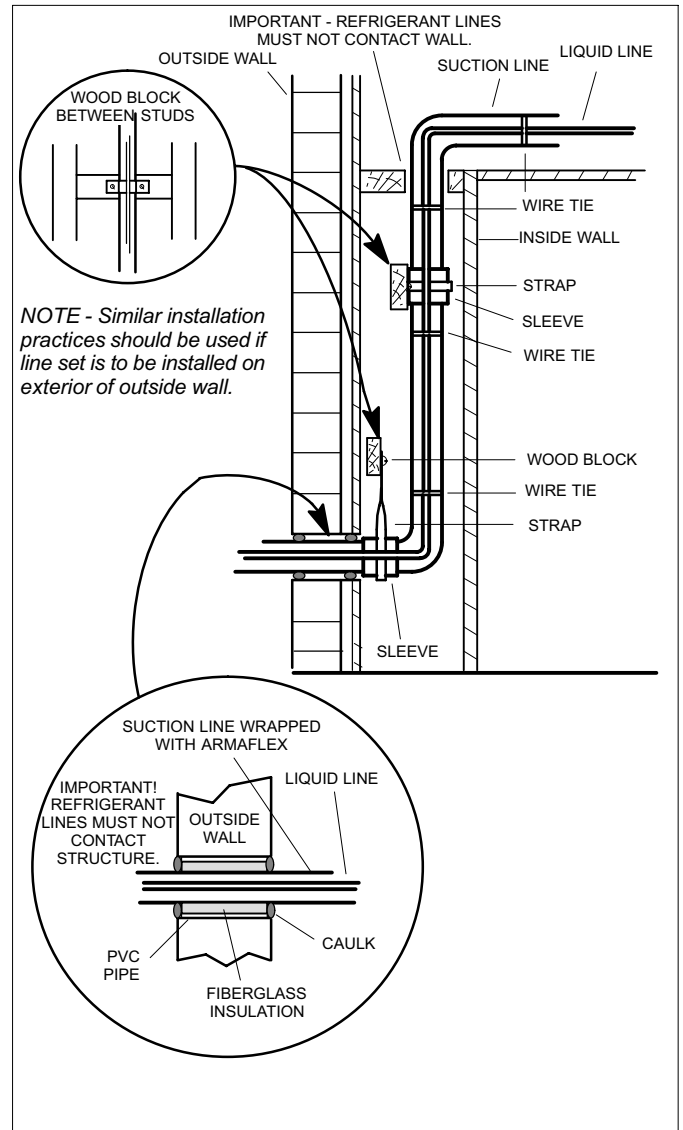

Figure 11. Refrigerant Line Set: Installing Vertical Runs (New Construction Shown)

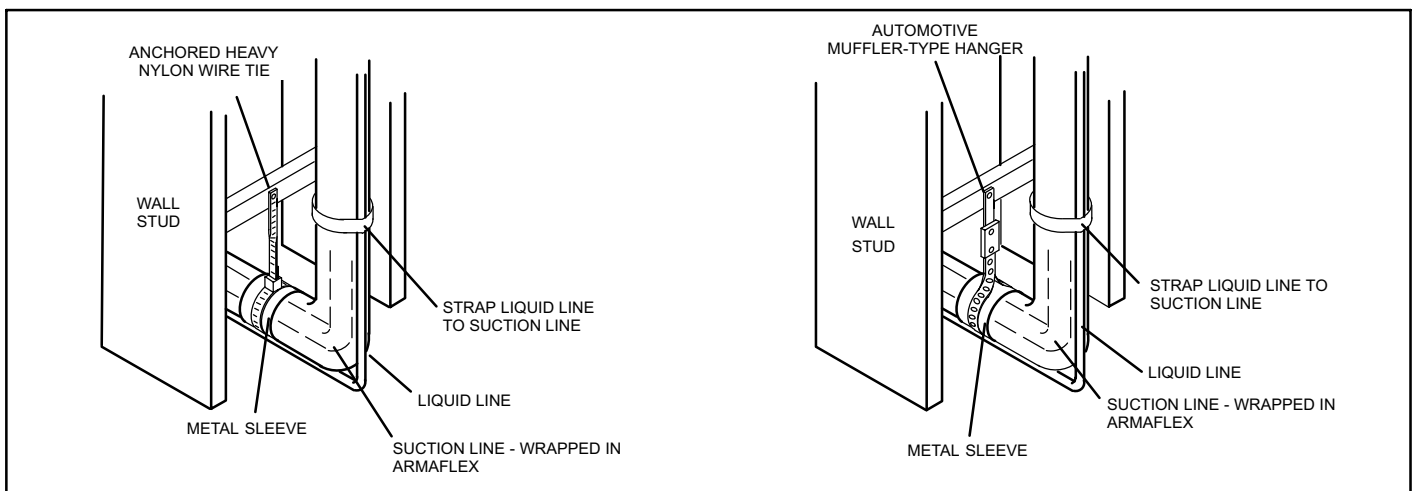

Figure 12. Refrigerant Line Set: Transition from Vertical to Horizontal

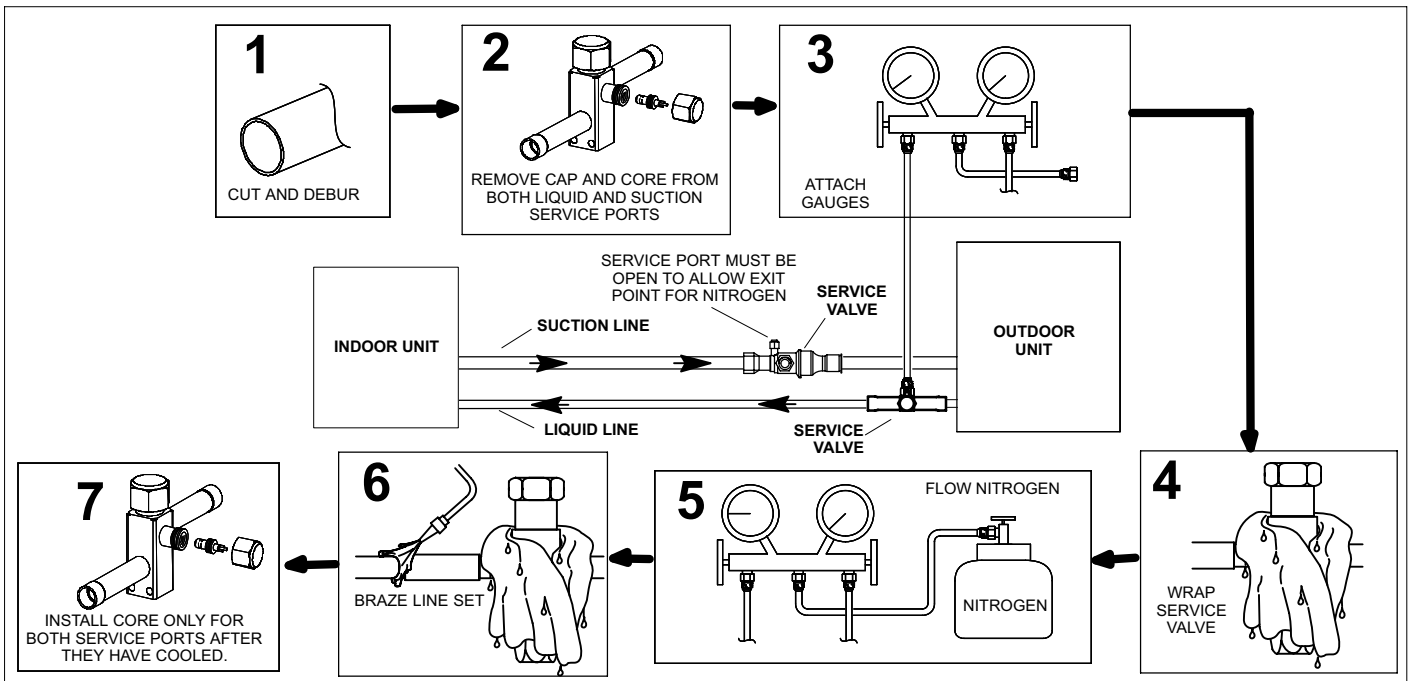

Figure 13. Brazing Connections

Brazing Connections

Use the following procedure to braze the line set to the new outdoor unit. Figure 13 is provided as a general guide for preparing to braze the line set to the outdoor unit.

⚠ WARNING



Danger of fire. Bleeding the refrigerant charge from only the high side may result in the low side shell and suction tubing being pressurized. Application of a brazing torch while pressurized may result in ignition of the refrigerant and oil mixture - check the high and low pressures before unbrazing.

⚠ WARNING



When using a high pressure gas such as dry nitrogen to pressurize a refrigeration or air conditioning system, use a regulator that can control the pressure down to 1 or 2 psig (6.9 to 13.8 kPa).

1. Cut ends of the refrigerant lines square (free from nicks or dents). Deburr the ends. The pipe must remain round, do not pinch end of the line.
2. Remove service cap and core from both the suction and liquid line service ports.

3. Connect gauge low pressure side to liquid line service valve.
4. To protect components during brazing, wrap a wet cloth around the liquid line service valve body and copper tube stub and use another wet cloth underneath the valve body to protect the base paint.
5. Flow regulated nitrogen (at 1 to 2 psig) through the refrigeration gauge set into the valve stem port connection on the liquid line service valve and out of the valve stem port connection on the suction service valve. The TXV metering device at the indoor unit coil will allow low pressure nitrogen to flow through the system.)

NOTE - The fixed orifice or TXV metering device at the indoor unit will allow low pressure nitrogen to flow through the system.)

NOTE - Use silver alloy brazing rods with five or six percent minimum silver alloy for copper-to-copper brazing or 45 percent silver alloy for copper-to-brass or copper-to-steel brazing.

6. Braze the line to the liquid line service valve. Turn off nitrogen flow.

⚠ IMPORTANT

Repeat procedure starting at paragraph 4 for brazing the suction line to service port valve.

7. After all connections have been brazed, disconnect manifold gauge set from service ports and remove wrapping. Reinstall the service port core for both of the outdoor unit's service valves.

Removing Indoor Unit Metering Device

Remove the existing HCFC-22 refrigerant flow control orifice or thermal expansion valve from the indoor coil.

REPLACEMENT PARTS

If replacement parts are necessary for the indoor unit, order kit [69J46](#). The kit includes:

- 10 — Brass nuts for liquid line assemblies
- 20 — Teflon rings
- 10 — Liquid line orifice housings
- 10 — Liquid line assemblies

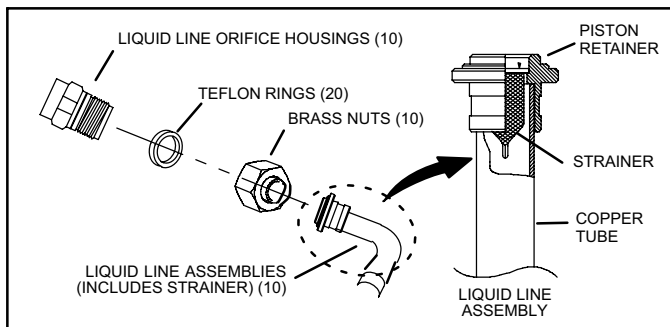

Figure 14. [69J46](#) Kit Components

TYPICAL FIXED ORIFICE REMOVAL PROCEDURE

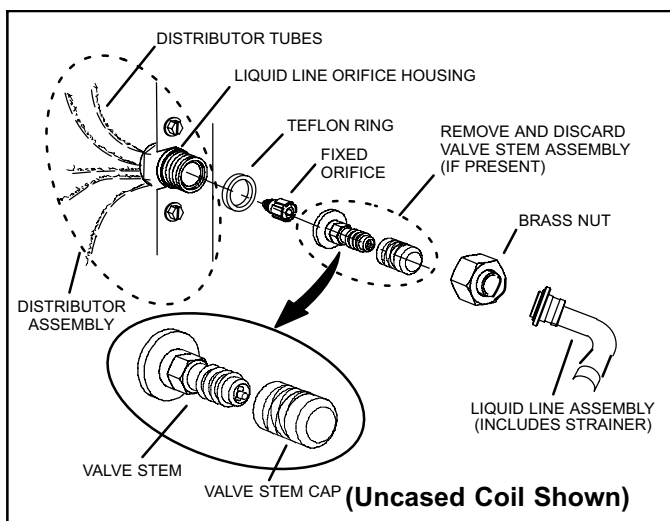

Figure 15. Typical Fixed Orifice Removal

1. On fully cased coils, remove the coil access and plumbing panels.
2. Remove any shipping clamps holding the liquid line and distributor assembly.
3. Using two wrenches, disconnect liquid line from liquid line orifice housing. Take care not to twist or damage distributor tubes during this process.
4. Remove and discard fixed orifice, valve stem assembly if present and Teflon ring as illustrated in figure 15.

TYPICAL TXV REMOVAL PROCEDURE

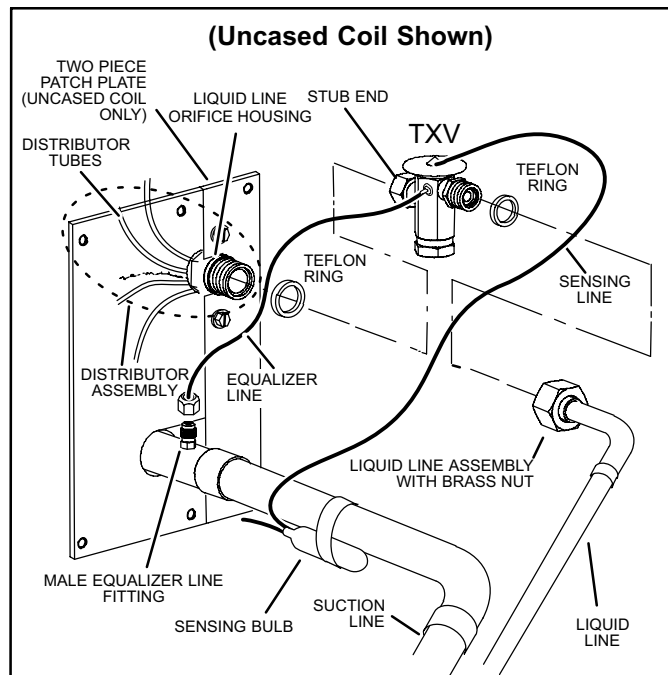

Figure 16. Typical TXV Removal

1. On fully cased coils, remove the coil access and plumbing panels.
2. Remove any shipping clamps holding the liquid line and distributor assembly.
3. Disconnect the equalizer line from the TXV equalizer line fitting on the suction line.
4. Remove the suction line sensing bulb as illustrated in figure 16.
5. Disconnect the liquid line from the TXV at the liquid line assembly.
6. Disconnect the TXV from the liquid line orifice housing. Take care not to twist or damage distributor tubes during this process.
7. Remove and discard TXV and the two Teflon rings as illustrated in figure 16.

Installing New Indoor Unit Metering Device

13ACD units can be configured for use in with HCFC-22 fixed orifice or TXV metering devices. This section provides instructions on installing either a fixed orifice or TXV refrigerant metering device.

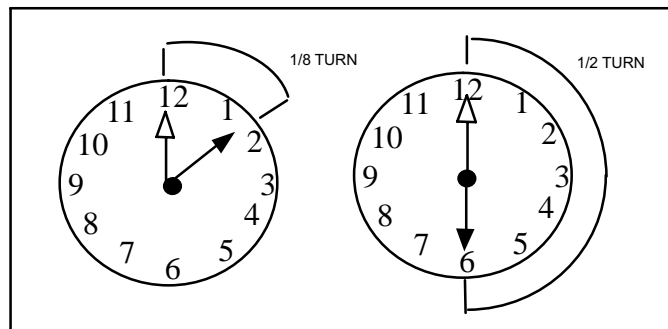

Figure 17. Tightening Distance

TYPICAL FIXED ORIFICE INSTALLATION PROCEDURE

1. Installed the provided RFC orifice that was supplied with the outdoor unit as illustrated in figure 18.
2. Ensure that the fixed orifice supplied with the outdoor unit is installed with the nylon seat pointing toward the liquid line orifice housing.
3. Apply a small amount of refrigerant oil on the Teflon ring and insert securely into the liquid line orifice housing.
4. Attach the liquid line assembly to the liquid line orifice housing. Finger tighten and use an appropriately sized wrench to turn an additional 1/2 turn clockwise as illustrated in figure 17, or 20 ft-lb.
5. Place the supplied fixed orifice sticker on the indoor cabinet after installation.

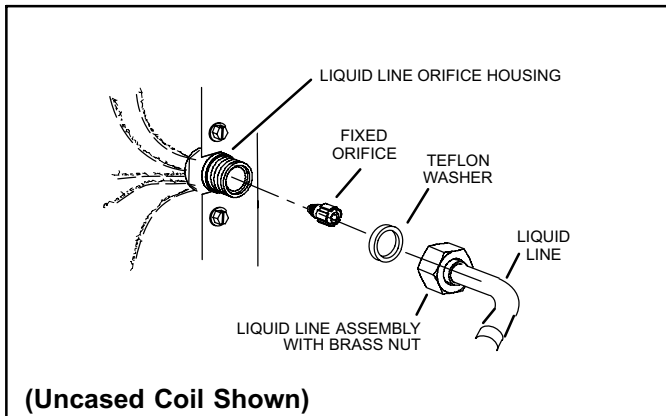

Figure 18. Typical Fixed Orifice Installation

See the 13ACD Engineering Handbook for approved TXV indoor/outdoor unit match-ups and application information. Table 4 lists both the Lennox catalog and part numbers for the TXV kit required for each unit model. Figure 19 illustrates the kit components and quantities.

Table 3. Indoor Fixed Orifice Kits

Model	Catalog Number	Part Number	Drill Size
018	10W95	100484-07	0.055
024	98M12	100484-12	0.062
030	11W00	100484-16	0.067
036	98M78	100484-24	0.076
042	10W86	100484-28	0.080
048	98M14	100484-36	0.089
060	98M15	100484-45	0.099

Use the Lennox catalog number to order a new or replacement fixed orifice kit.

The kit includes:

- 1 — Fixed orifice

- 1 — Fixed orifice extractor
- 1 — Teflon ring
- 1 — Fixed orifice sticker

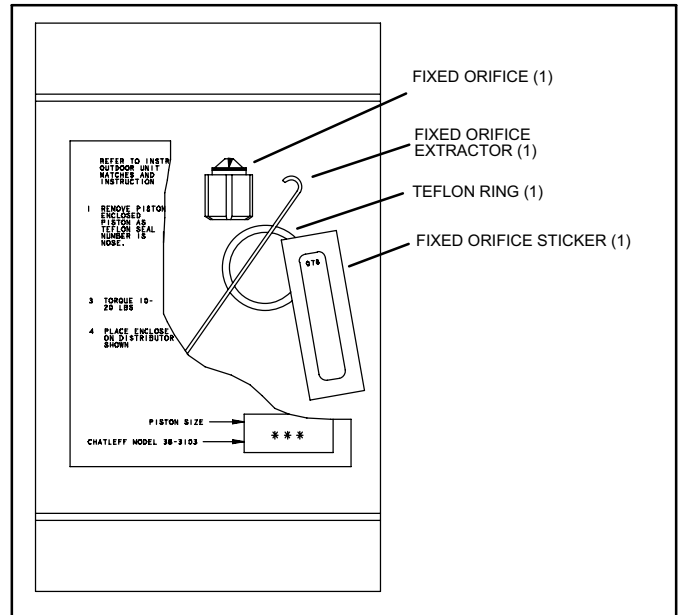

Figure 19. Fixed Orifice Kit Components

TYPICAL TXV INSTALLATION PROCEDURE

The TXV unit can be installed internal or external to the indoor coil. In applications where an uncased coil is being installed in a field-provided plenum, install the TXV in a manner that will provide access for field servicing of the TXV. Refer to Figure 20 for reference during installation of TXV unit.

1. Install one of the provided Teflon rings around the stubbed end of the TXV and lightly lubricate the connector threads and expose surface of the Teflon ring with refrigerant oil.
2. Attach the stubbed end of the kit valve to the liquid line orifice housing. Finger tighten and use an appropriately sized wrench to turn an additional 1/2 turn clockwise as illustrated in figure 17, or 20 ft-lb.
3. Place the remaining Teflon washer around the other end of the TXV. Lightly lubricate connector threads and expose surface of the Teflon ring with refrigerant oil.
4. Attach the liquid line assembly to the TXV. Finger tighten and use an appropriately sized wrench to turn an additional 1/2 turn clockwise as illustrated in figure 17, or 20 ft-lb.
5. Attach the suction line sensing bulb in the proper orientation as illustrated in figure 21 using the clamp an screws provided.

NOTE - Insulating the sensing bulb once installed may be required when the bulb location is external to the coil casing.

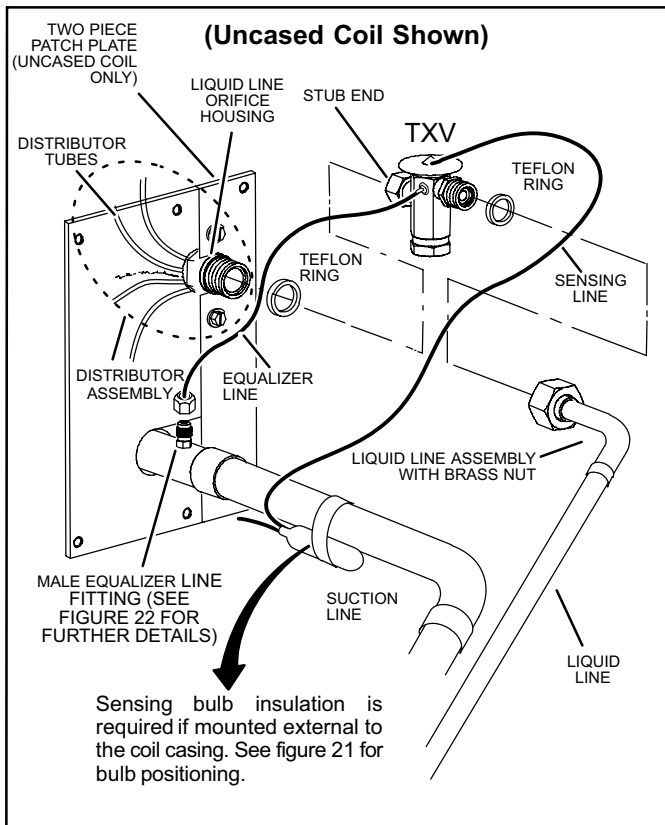

Figure 20. Typical TXV Installation

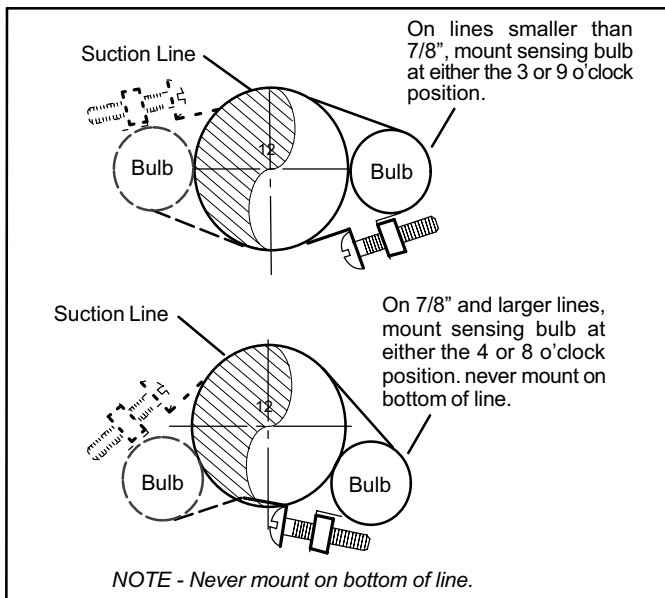

Figure 21. TXV Sensing Bulb Installation

6. Remove and discard either the flare seal cap or flare nut with copper flare seal bonnet from the equalizer line port on the suction line as illustrated in figure 22.

⚠ IMPORTANT
When removing the brass nut, ensure that the copper flare seal bonnet is removed.

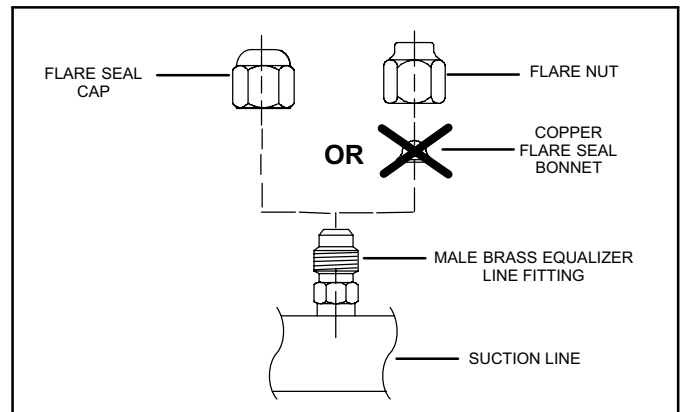

Figure 22. Copper Flare Seal Bonnet Removal

7. Connect the equalizer line from the TXV to the equalizer suction port on the suction line. Finger tighten the flare nut plus 1/8 turn (7 ft-lbs) as illustrated in figure 17.

NOTE - To prevent any possibility of water damage, properly insulate all parts of the TXV assembly that may sweat due to temperature differences between the valve and its surrounding ambient temperatures.

See the 13ACD Engineering Handbook for approved TXV match-ups and application information.

Table 4. Indoor TXV Indoor Kits

Model	Catalog Number	Part Number
-018, -024, -030 and -036	26K34	LB-85663J
-042, -048 and -060	26K35	LB-85663k

Use the Lennox catalog number to order a TXV kit.

The above reference kits include:

- 1 — TXV
- 2 — Teflon rings
- 1 — 1 1/4" wide copper mounting strap for sensing bulb
- 2 — #10 hex head bolts and nuts for securing sensing bulb

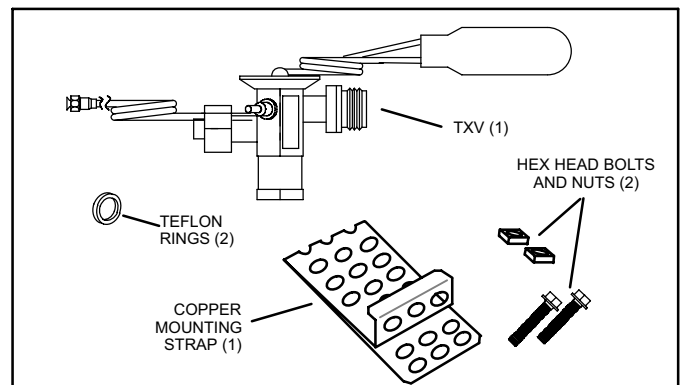

Figure 23. TXV Kit Components

Testing for Leaks

⚠ IMPORTANT
Leak detector must be capable of sensing HFC refrigerant.

WARNING

Refrigerant can be harmful if it is inhaled. Refrigerant must be used and recovered responsibly.

Failure to follow this warning may result in personal injury or death.

WARNING



Fire, Explosion and Personal Safety Hazard.

Failure to follow this warning could result in damage, personal injury or death.

Never use oxygen to pressurize or purge refrigeration lines. Oxygen, when exposed to a spark or open flame, can cause damage by fire and/or an explosion, that could result in personal injury or death.

After the line set has been connected to both the indoor and outdoor units, check the line set connections at both the indoor and outdoor units unit for leaks. Use the following procedure to test for leaks:

1. Connect an HCFC-22 manifold gauge set high pressure hose to the suction valve service port.

NOTE - Normally, the high pressure hose is connected to the liquid line port; however, connecting it to the suction port better protects the manifold gauge set from high pressure damage.

2. With both manifold valves closed, connect the cylinder of HCFC-22 refrigerant to the center port of the manifold gauge set. Open the valve on the HCFC-22 cylinder (suction only).
3. Open the high pressure side of the manifold to allow HCFC-22 into the line set and indoor unit.
4. Weigh in a trace amount of HCFC-22. [A trace amount is a maximum of two ounces (57 g) refrigerant or three pounds (31 kPa) pressure].
5. Close the valve on the HCFC-22 cylinder and the valve on the high pressure side of the manifold gauge set.
6. Disconnect the HCFC-22 cylinder.
7. Connect a cylinder of dry nitrogen with a pressure regulating valve to the center port of the manifold gauge set.

NOTE - Amounts of refrigerant will vary with line lengths.

8. Adjust dry nitrogen pressure to 150 psig (1034 kPa).
9. Open the valve on the high side of the manifold gauge set in order to pressurize the line set and the indoor unit.
10. After a few minutes, open one of the service valve ports and verify that the refrigerant added to the system earlier is measurable with a leak detector.
11. Check all joints for leaks.
12. Purge dry nitrogen and HFC-410A mixture.

13. Correct any leaks and recheck.

14. After leak testing disconnect gauges from service ports.

Evacuating the System

WARNING

Danger of Equipment Damage. Avoid deep vacuum operation. Do not use compressors to evacuate a system. Extremely low vacuums can cause internal arcing and compressor failure. Damage caused by deep vacuum operation will void warranty.

IMPORTANT

Use a thermocouple or thermistor electronic vacuum gauge that is calibrated in microns. Use an instrument capable of accurately measuring down to 50 microns.

Evacuating the system of non-condensables is critical for proper operation of the unit. Non-condensables are defined as any gas that will not condense under temperatures and pressures present during operation of an air conditioning system. Non-condensables and water suction combine with refrigerant to produce substances that corrode copper piping and compressor parts.

1. Connect manifold gauge set to the service valve ports as follows:
 - low pressure gauge to *suction* line service valve
 - high pressure gauge to *liquid* line service valve
2. Connect micron gauge.
3. Connect the vacuum pump (with vacuum gauge) to the center port of the manifold gauge set.
4. Open both manifold valves and start the vacuum pump.
5. Evacuate the line set and indoor unit to an **absolute pressure** of 23,000 microns (29.01 inches of mercury).

*NOTE - During the early stages of evacuation, it is desirable to close the manifold gauge valve at least once to determine if there is a rapid rise in sure indicates a relatively large leak. If this occurs, **repeat the leak testing procedure.***

*NOTE - The term **absolute pressure** means the total actual pressure within a given volume or system, above the absolute zero of pressure. Absolute pressure in a vacuum is equal to atmospheric pressure minus vacuum pressure.*

6. When the absolute pressure reaches 23,000 microns (29.01 inches of mercury), close the manifold gauge valves, turn off the vacuum pump and disconnect the manifold gauge center port hose from vacuum pump. Attach the manifold center port hose to a dry nitrogen cylinder with pressure regulator set to 150 psig (1034 kPa) and purge the hose. Open the manifold gauge valves to break the vacuum in the line set and indoor unit. Close the manifold gauge valves.

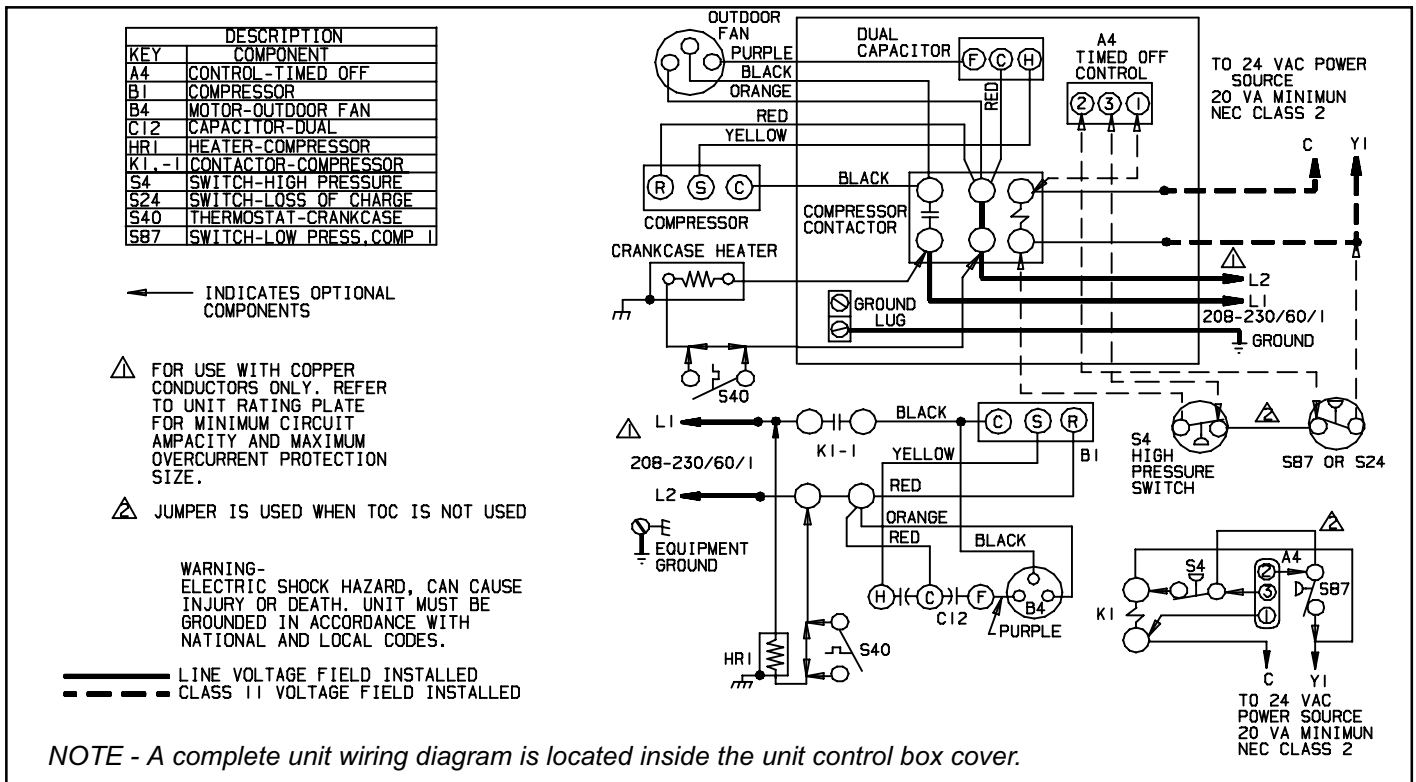

Figure 24. Typical Wiring Diagram

- Shut off the dry nitrogen cylinder and remove the manifold gauge hose from the cylinder. Open the manifold gauge valves to release the dry nitrogen from the line set and indoor unit.
- Reconnect the manifold gauge to the vacuum pump, turn the pump on, and continue to evacuate the line set and indoor unit until the absolute pressure does not rise above 500 microns (29.9 inches of mercury) within a 20-minute period after shutting off the vacuum pump and closing the manifold gauge valves.
- When the absolute pressure requirement above has been met, disconnect the manifold hose from the vacuum pump and connect it to an upright cylinder of HCFC-22 refrigerant. Open the manifold gauge valve 1 to 2 psig in order to release the vacuum in the line set and indoor unit.
- Close manifold gauge valves and shut off the HCFC-22 cylinder and remove the manifold gauge set.

Servicing Unit Delivered Void of Charge

If the system is void of refrigerant, clean the system using the procedure described below.

- Use nitrogen to pressurize the system and check for leaks. Repair all leaks.
- Evacuate the system to remove as much of the moisture as possible.
- Use nitrogen to break the vacuum and install a new filter drier in the system.

- Evacuate the system again. Then, weigh the appropriate amount of HCFC-22 refrigerant as listed on unit nameplate into the system.
- Monitor the system to determine the amount of moisture remaining in the oil. It may be necessary to replace the filter drier several times to achieve the required dryness level. **If system dryness is not verified, the compressor will fail in the future.**

Electrical Connections

⚠ WARNING

Electric Shock Hazard. Can cause injury or death.

Line voltage is present at all components on units with single-pole contactors, even when unit is not in operation!

Unit may have multiple power supplies. Disconnect all remote electric power supplies before opening access panel.

Unit must be grounded in accordance with national and local codes.

Refer to the indoor unit installation instruction for additional wiring application diagrams and refer to unit nameplate for minimum circuit ampacity and maximum overcurrent protection size. Figures 26 and 24 illustrate typical outdoor unit wiring diagrams for the 13ACD series heat pumps.

- In the U.S.A., wiring must conform with current local codes and the current National Electric Code (NEC).

- In Canada, wiring must conform with current local codes and the current Canadian Electrical Code (CEC).

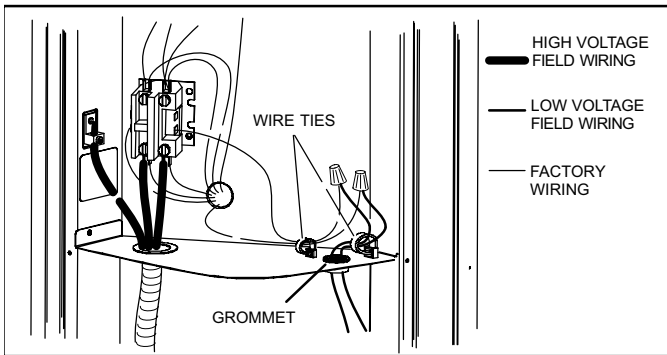

Figure 25. Separating High/Low Voltage Field Wiring (Typical Field Wiring)

WIRING CONNECTIONS

1. Install line voltage power supply to unit from a properly sized disconnect switch. Any excess high voltage field wiring should be trimmed or secured away from the low voltage field wiring.
2. Ground unit at unit disconnect switch or to an earth ground.
3. Connect conduit to the unit using provided conduit bushing.
4. Install room thermostat (ordered separately) on an inside wall approximately in the center of the conditioned area and five feet (1.5 m) from the floor. It should not be installed on an outside wall or where it can be affected by sunlight, drafts or vibrations.

NOTE - For proper voltages, select thermostat wire gauge per the following table:

Table 5. Wire Run Lengths

Wire run length	AWG #	Insulation type
Less than 100 feet (30 m)	18	Color-coded with a minimum temperature rating of 35°C.
More than 100 feet (30 m)	16	

5. Install low voltage wiring from outdoor to indoor unit and from thermostat to indoor unit as illustrated in figures 26 and 24.
6. Do not bundle any excess 24VAC control wire inside control box. Run control wire through installed wire tie and tighten wire tie to provided low voltage strain relief and to maintain separation of field installed low and high voltage circuits.

NOTE - 24VAC, Class II circuit connections are made in the low voltage junction box

NOTE - Units are approved for use only with copper conductors.

NOTE - To facilitate conduit, a hole is in the bottom of the control box. Connect conduit to the control box using a proper conduit fitting.

NOTE - See unit wiring diagram for power supply connections. If indoor unit is not equipped with blower relay. It must be field-provided and installed (P-8-3251 or equivalent)

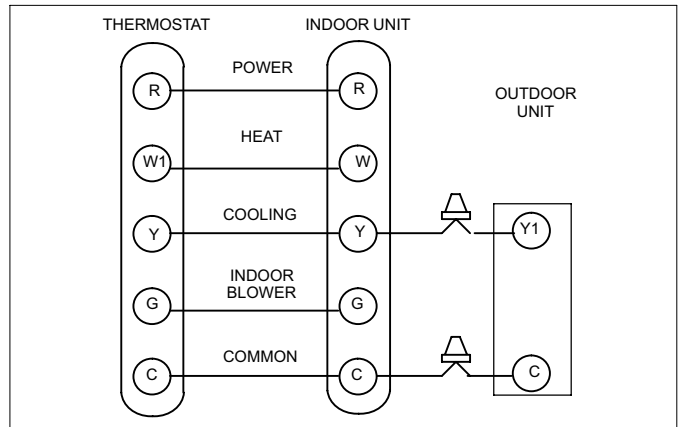

Figure 26. Typical Field Low Voltage Wiring

Start-Up and Charging Procedures

! IMPORTANT

If unit is equipped with a crankcase heater, it should be energized 24 hours before unit start-up to prevent compressor damage as a result of slugging.

1. Rotate fan to check for binding.
2. Inspect all factory- and field-installed wiring for loose connections.
3. After evacuation is complete, open the liquid line and suction line service valves to release the refrigerant charge (contained in outdoor unit) into the system.
4. Replace the stem caps and tighten as specified in *Operating Service Valves* on page 2.
5. Check voltage supply at the disconnect switch. The voltage must be within the range listed on the unit's nameplate. If not, do not start the equipment until you have consulted with the power company and the voltage condition has been corrected.
6. Set the thermostat for a cooling demand. Turn on power to the indoor indoor unit and close the outdoor unit disconnect switch to start the unit.
7. Recheck voltage while the unit is running. Power must be within range shown on the nameplate.
8. Check system for sufficient refrigerate by using the procedures listed under *Testing and Charging System*.

SETTING UP TO CHECK CHARGE

1. Close manifold gauge set valves. Connect the center manifold hose to an upright cylinder of HCFC-22.
2. Connect the manifold gauge set to the unit's service ports as illustrated in figure 1.
 - low pressure gauge to **suction service port**
 - high pressure gauge to **liquid service port**

INDOOR AIRFLOW CHECK

Check airflow using the Delta-T (DT) process using the illustration in figure 27.

DETERMINING CHARGE METHOD

Use the illustration in figure 28 to determine the correct charging method.

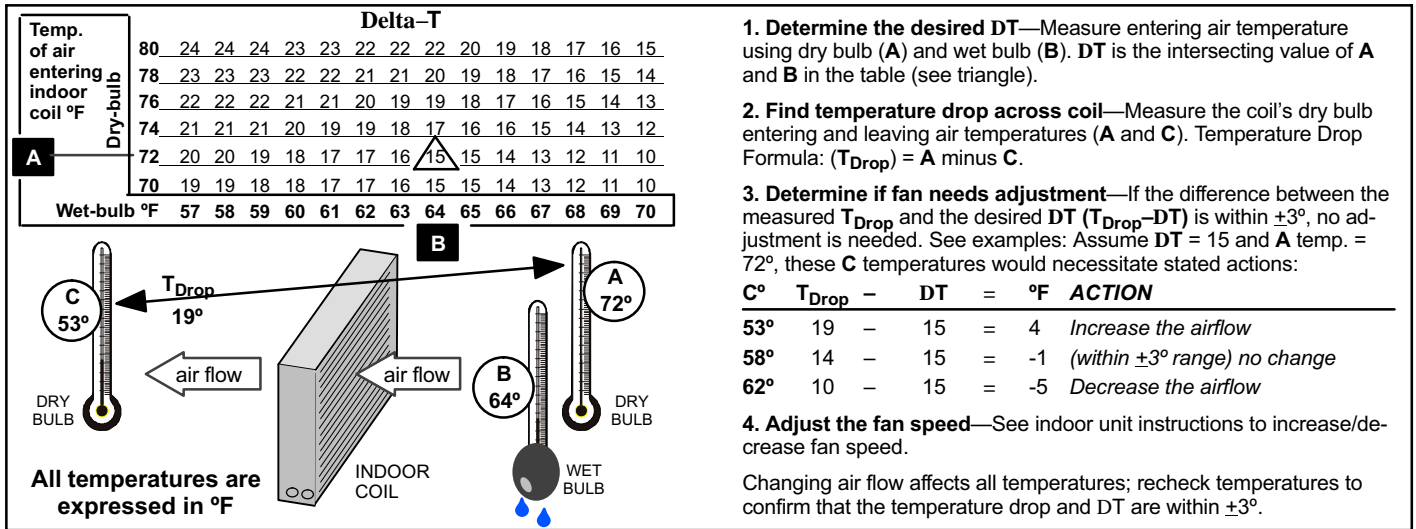

Figure 27. Checking Indoor Airflow over Evaporator Coil using Delta-T Chart

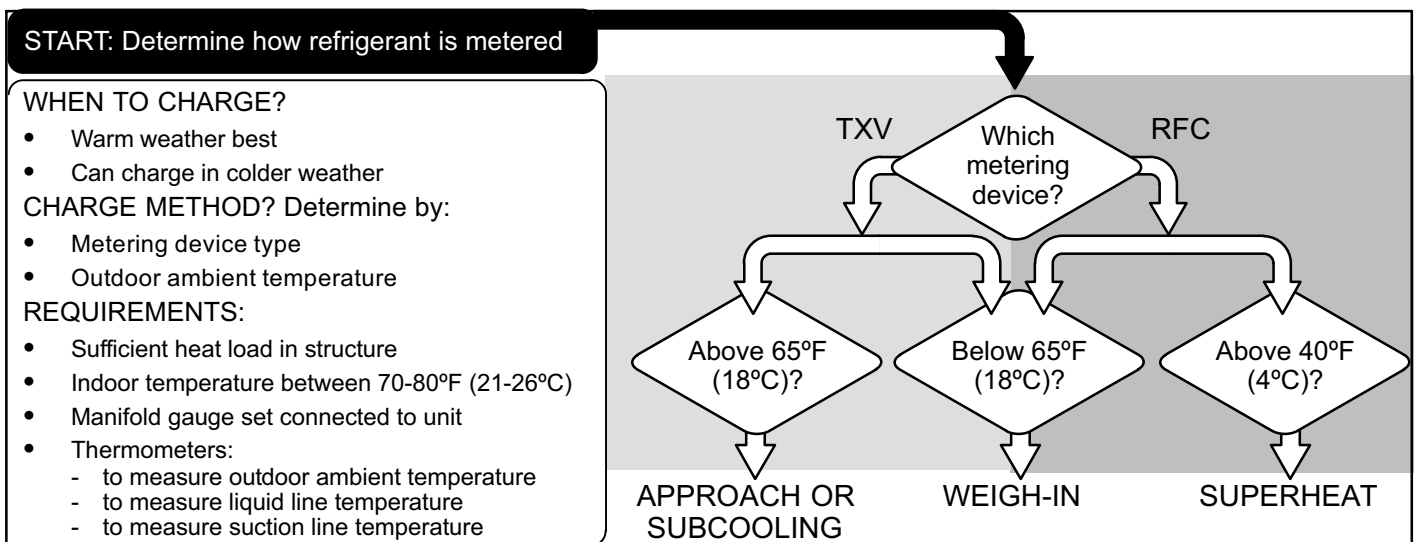

Figure 28. Determining Charge Method

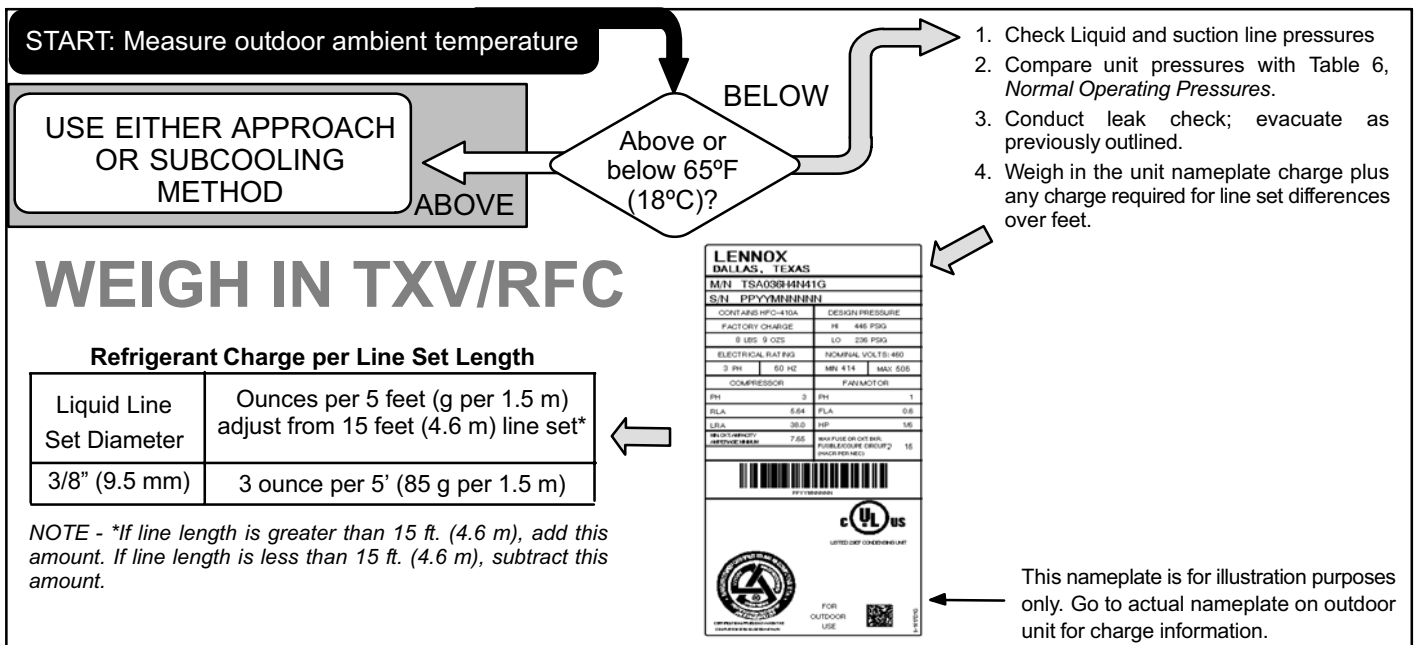

Figure 29. HCFC-22 Weigh In TXV Method

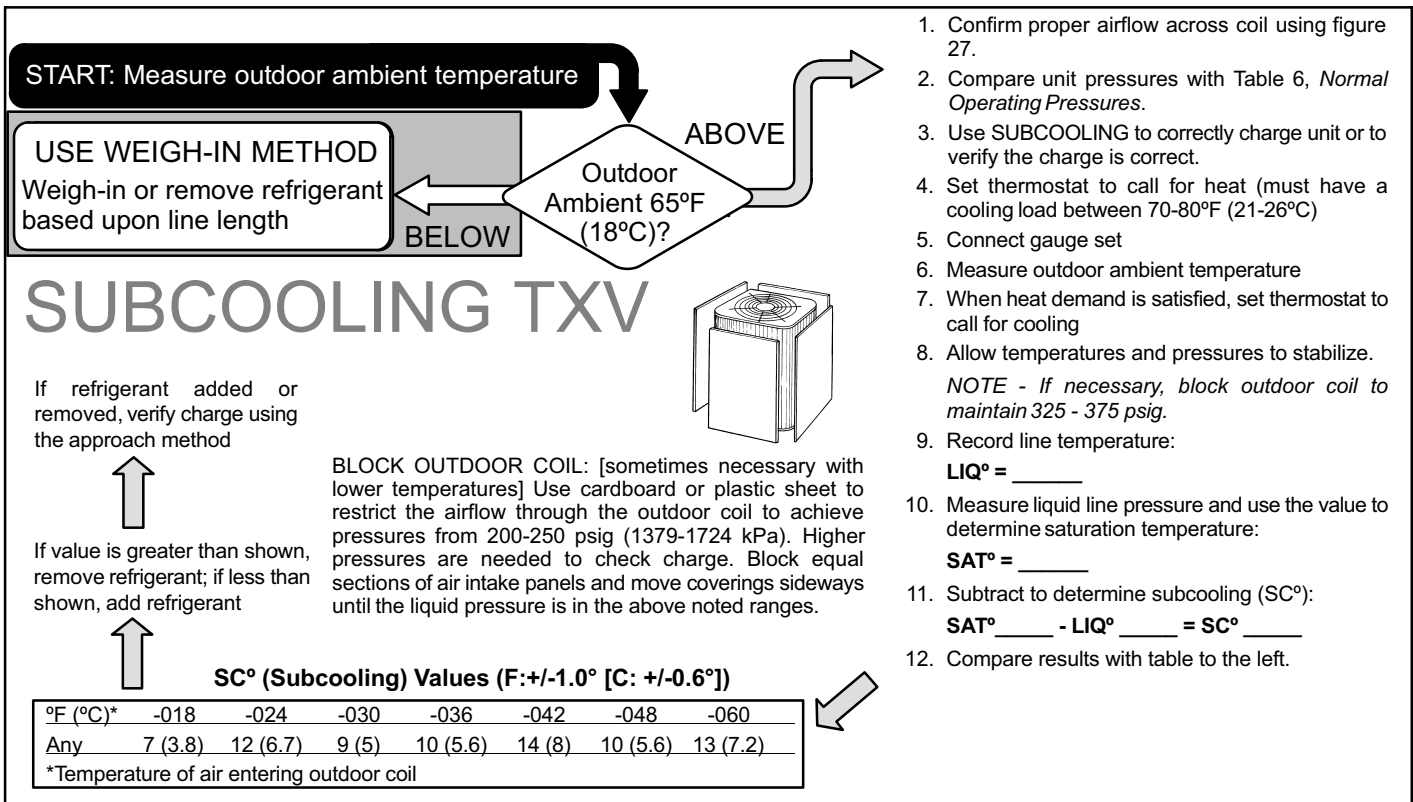

Figure 30. HCFC-22 Subcooling TXV Charge

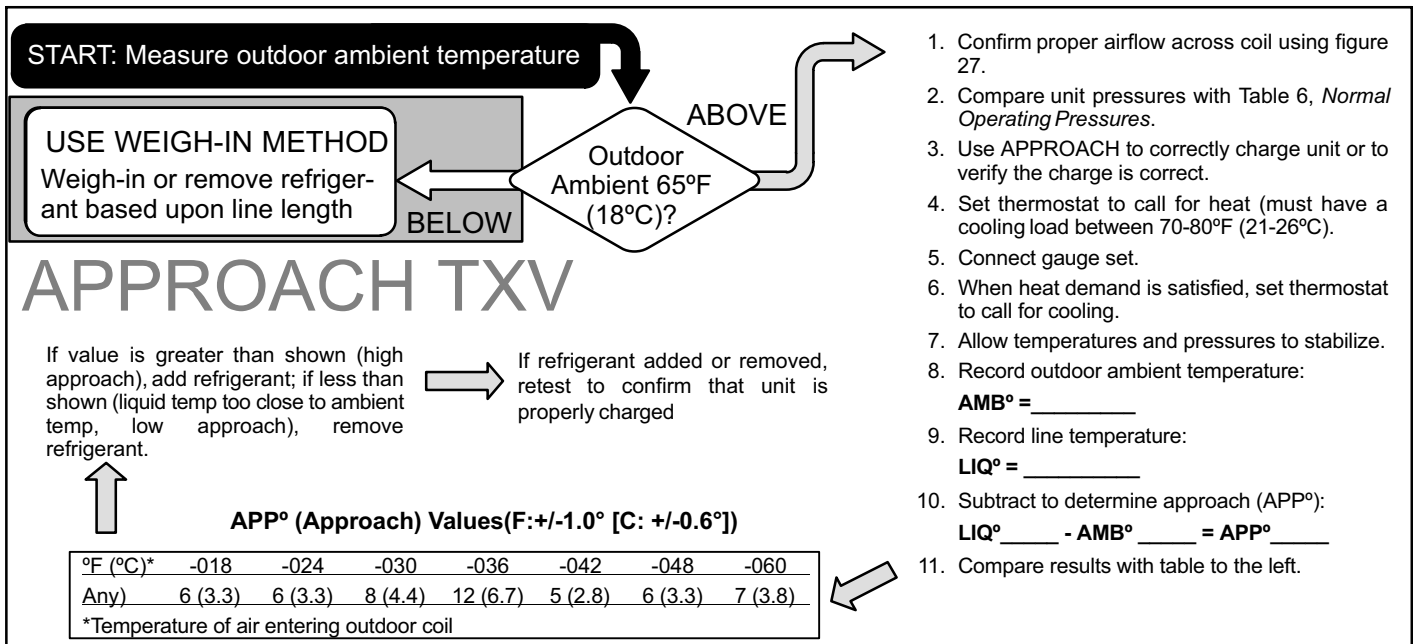

Figure 31. HCFC-22 Approach TXV Charge

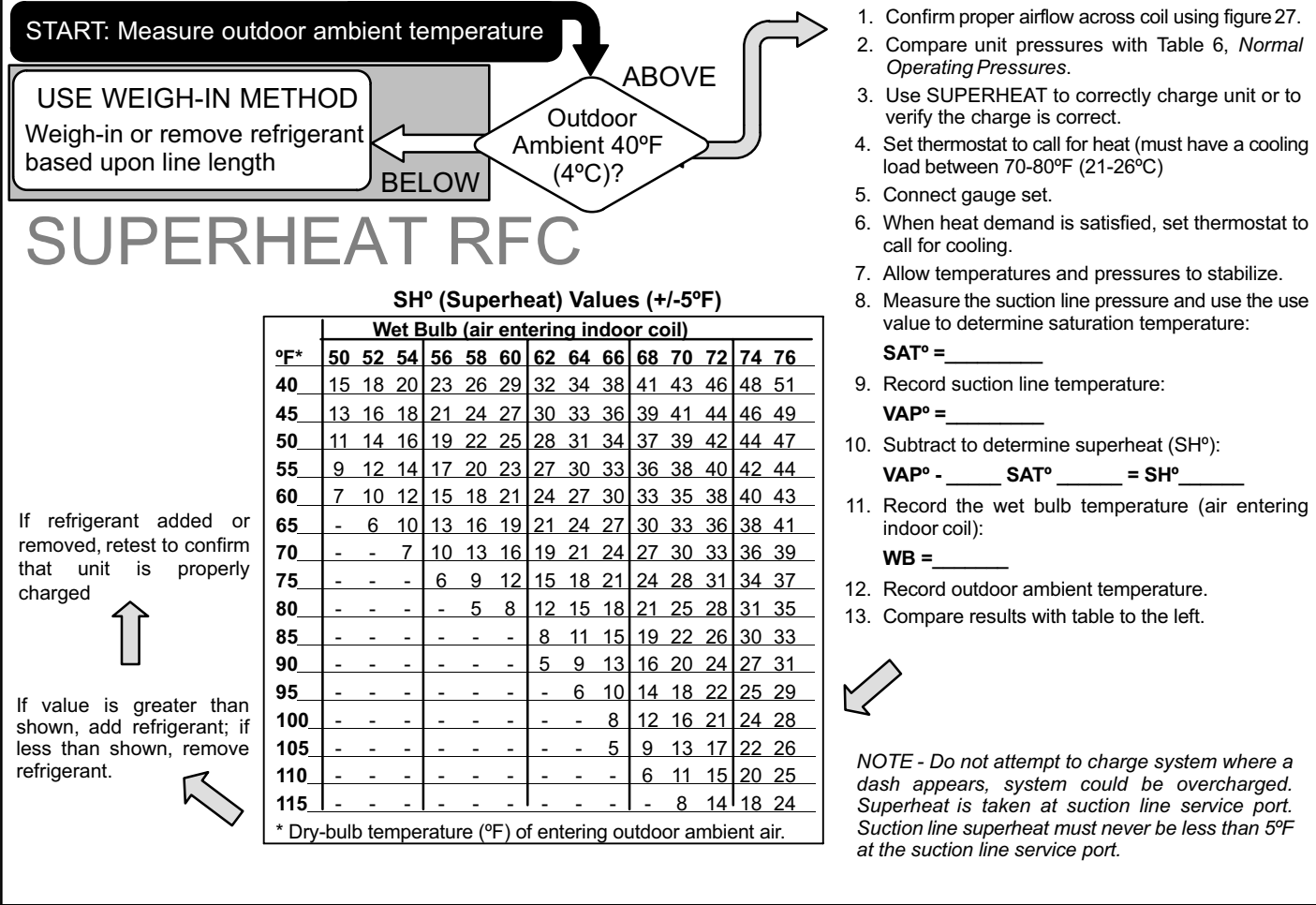

Figure 32. HCFC-22 Superheat RFC Charge

Table 6. HCFC-22 Normal Operating Pressures (Liquid +10 and Suction +5 psig)

! IMPORTANT

Use this table to perform maintenance checks; it is not a procedure for charging the system. Minor variations in these pressures may be due to differences in installations. Significant deviations could mean that the system is not properly charged or that a problem exists with some component in the system.

13ACD	-018	-024	-030	-036	-042	-048	-060
°F (°C)*	Liquid / Suction	Liquid / Suction	Liquid / Suction	Liquid / Suction	Liquid / Suction	Liquid / Suction	Liquid / Suction
Expansion Valve (TXV)							
65 (18)	138 / 79	148 / 79	147 / 75	155 / 79	147 / 78	144 / 77	152 / 73
70 (21)	148 / 80	160 / 79	159 / 75	169 / 80	158 / 78	152 / 77	164 / 75
75 (24)	160 / 80	174 / 80	172 / 76	183 / 81	172 / 79	163 / 78	177 / 77
80 (27)	174 / 81	188 / 81	186 / 77	199 / 81	189 / 79	179 / 78	192 / 78
85 (29)	188 / 81	203 / 81	201 / 77	215 / 82	205 / 80	195 / 79	208 / 79
90 (32)	204 / 81	220 / 82	216 / 78	233 / 82	222 / 81	212 / 80	225 / 80
95 (35)	219 / 82	236 / 83	233 / 79	252 / 83	241 / 81	229 / 80	243 / 80
100 (38)	236 / 82	253 / 83	250 / 80	271 / 83	259 / 82	245 / 81	261 / 81
105 (41)	253 / 83	272 / 84	268 / 80	291 / 84	279 / 82	265 / 81	280 / 82
110 (43)	272 / 84	291 / 85	287 / 81	311 / 85	299 / 83	287 / 82	299 / 83
115 (45)	291 / 84	311 / 85	306 / 82	331 / 86	320 / 84	309 / 83	320 / 83
Fixed Orifice (RFC)							
65 (18)	139 / 67	147 / 71	148 / 65	162 / 75	158 / 72	151 / 71	152 / 68
70 (21)	149 / 70	159 / 73	161 / 67	174 / 76	170 / 75	161 / 73	165 / 71
75 (24)	161 / 74	172 / 75	175 / 70	187 / 78	182 / 76	172 / 75	178 / 73
80 (27)	175 / 77	186 / 77	190 / 73	201 / 79	195 / 78	185 / 76	193 / 76
85 (29)	189 / 79	200 / 79	205 / 75	215 / 81	209 / 80	198 / 77	208 / 78
90 (32)	203 / 81	216 / 81	221 / 77	231 / 82	224 / 81	213 / 79	224 / 80
95 (35)	218 / 82	232 / 82	237 / 79	247 / 83	240 / 82	227 / 80	239 / 81
100 (38)	234 / 83	247 / 83	254 / 80	265 / 84	256 / 84	243 / 81	258 / 82
105 (41)	251 / 85	264 / 85	271 / 81	283 / 85	273 / 85	259 / 82	276 / 83
110 (43)	269 / 86	285 / 86	289 / 82	302 / 86	290 / 86	276 / 84	294 / 85
115 (45)	287 / 87	302 / 87	308 / 83	321 / 87	310 / 87	293 / 85	313 / 86

INSTALLING SERVICE VALVE CAPS

Disconnect gauge set and re-install both the liquid and suction service valve caps.

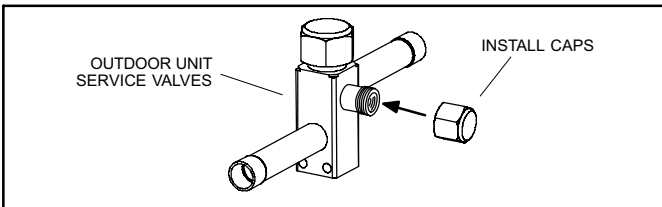

Figure 33. Installing Service Valve Caps

System Operation

The outdoor unit and indoor blower cycle on demand from the room thermostat. When the thermostat blower switch is in the **ON** position, the indoor blower operates continuously.

Maintenance

! WARNING



Electric shock hazard. Can cause injury or death. Before attempting to perform any service or maintenance, turn the electrical power to unit **OFF** at disconnect switch(es). Unit may have multiple power supplies.

! WARNING

Improper installation, adjustment, alteration, service or maintenance can cause personal injury, loss of life, or damage to property.

Installation and service must be performed by a licensed professional installer (or equivalent) or a service agency.

At the beginning of each cooling season, the system should be checked as follows:

OUTDOOR UNIT

1. Clean and inspect outdoor coil (may be flushed with a water hose). Ensure power is off before cleaning.
2. Outdoor unit fan motor is pre-lubricated and sealed. No further lubrication is needed.
3. Visually inspect all connecting lines, joints and coils for evidence of oil leaks.
4. Check all wiring for loose connections.
5. Check for correct voltage at unit (unit operating).
6. Check amp draw on outdoor fan motor.

UNIT NAMEPLATE: _____ ACTUAL: _____

7. Inspect drain holes in coil compartment base and clean if necessary.

NOTE - If insufficient heating or cooling occurs, the unit should be gauged and refrigerant charge should be checked.

INDOOR COIL

1. Clean coil if necessary.
2. Check connecting lines, joints and coil for evidence of oil leaks.
3. Check condensate line and clean if necessary.

INDOOR UNIT

1. Clean or change filters.
2. Blower motors are prelubricated and permanently sealed. No more lubrication is needed.
3. Adjust blower speed for cooling. Measure the pressure drop over the coil to determine the correct blower CFM. Refer to the unit information service manual for pressure drop tables and procedure.
4. *Belt Drive Blowers* - Check belt for wear and proper tension.
5. Check all wiring for loose connections.
6. Check for correct voltage at unit. (blower operating)
7. Check amp draw on blower motor.

UNIT NAMEPLATE: _____ ACTUAL: _____

OPTIONAL ACCESSORIES

Refer to the Engineering Handbook for optional accessories that may apply to this unit. The following may or may not apply:

Homeowner Information

⚠ WARNING



Electric shock hazard. Can cause injury or death. Before attempting to perform any service or maintenance, turn the electrical power to unit OFF at disconnect switch(es). Unit may have multiple power supplies.

⚠ IMPORTANT

Sprinklers and soaker hoses should not be installed where they could cause prolonged exposure to the outdoor unit by treated water. Prolonged exposure of the unit to treated water (i.e., sprinkler systems, soakers, waste water, etc.) will corrode the surface of steel and aluminum parts and diminish performance and longevity of the unit.

NOTE - A white residue may appear on the coil guards and grilles on outdoor units. The residue is a non-toxic byproduct of manufacturing the flexible coating. It can be removed by wiping the coil guard with a cloth.

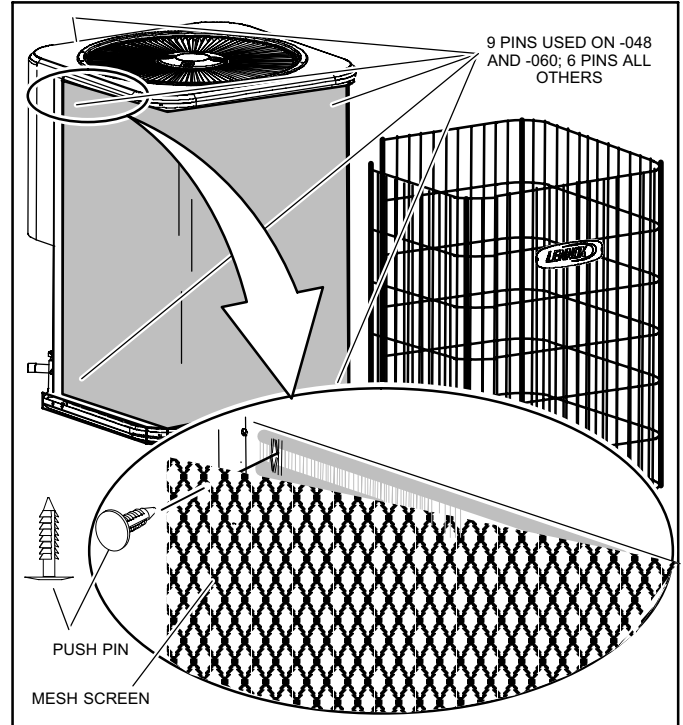

Figure 34. Cleaning debris from mesh

Maintenance and service must be performed by a qualified installer or service agency. At the beginning of each cooling season, the system should be checked as follows:

1. Make sure power is off before cleaning. Clean and inspect outdoor coil. The coil may be flushed with a water hose.
2. The outdoor coil is protected by an inner mesh screen and a wire cage (see figure 34). If debris has collected between the mesh screen and the coil and cannot be dislodged by spraying unpressurized water from inside coil surface to the outside, the mesh may be removed by first removing the top of the unit which will allow for removal of the wire cage.
3. Then, using pliers to grip the head of the push pins, pull straight out to extract the push pins along one side of the coil. If necessary, remove the push pins along the back of the unit; it is usually unnecessary to fully remove the inner mesh screen.
4. Drape the mesh screen back and wash the coil. When all the debris has been removed from the coil, reinstall the mesh screen by positioning it in its original position

and reinserting the push pin. No tool is required to push the pin back into the same slot in the fins.

- If the push pin is loose and tends not to stay in place, brush the fins with a fin brush (22 fins/in). Line up the push pin a couple fins to the right or left of the original hole and re-insert the pin.

THERMOSTAT OPERATION

Thermostat operations vary from one thermostat to another. The following provides general operation procedures. Refer to the user's information manual provided with your thermostat for specific operation details.

Temperature Setting Levers	Set the lever or dial to the desired temperature setpoints for both heating and cooling. Avoid frequent temperature adjustment; turning the unit off—then back on—before pressures can equalize will put unusual stress on the unit's compressor.
Fan Switch	In AUTO or INT (intermittent) mode, the blower operates only when the thermostat calls for heating or cooling. This mode is generally preferred when humidity control is a priority. The ON or CONT mode provides continuous indoor blower operation, regardless of whether the compressor or furnace is operating. This mode is required when constant air circulation or filtering is desired.
System Switch	Set the system switch for heating, cooling or auto operation. The auto mode allows the system to automatically switch from heating mode to cooling mode to maintain predetermined comfort settings.
Temperature Indicator	The temperature indicator displays the actual room temperature.

PROGRAMMABLE THERMOSTATS

Your Lennox system may be controlled by a

programmable thermostat. These thermostats provide the added feature of programmable time-of-day setpoints for both heating and cooling. Refer to the user's information manual provided with your thermostat for operation details.

PRESERVICE CHECK

If your system fails to operate, check the following before calling for service:

- Make sure all electrical disconnect switches are ON.
- Make sure the room thermostat temperature selector AND the system switch are properly set.
- Replace any blown fuses, or reset circuit breakers.
- Make sure unit access panels are in place.
- Make sure air filter is clean.
- Locate and record unit model number before calling.

Optional Accessories

Refer to the *Lennox 13ACD Engineering Handbook* for the latest available accessories for this unit. Below is a list of accessories available at the time this instruction was published.

Optional Accessory	Catalog Number	Part Number
Compressor Start Kit	10J42	LB-31200BM
Loss of Charge Kit	94J47	LB-87620A
Sound Cover	69J03	69J0301
Replacement Liquid Line Drier	12L71	12L7101
Plastic Feet Kit	94J45	LB-87156A
Crankcase Heater - 40W	93M04	100499-01
High Pressure Kit	94J46	LB-87620A

Start-Up and Performance Checklist

Job Name _____	Job no. _____	Date _____
Job Location _____	City _____	State _____
Installer _____	City _____	State _____
Unit Model No. _____	Serial No. _____	Service Technician _____
Nameplate Voltage _____		
Rated Load Ampacity _____	Compressor _____	Outdoor Fan _____
Maximum Fuse or Circuit Breaker _____		
Electrical Connections Tight? <input type="checkbox"/>	Indoor Filter clean? <input type="checkbox"/>	Supply Voltage (Unit Off) _____
Indoor Blower RPM _____	S.P. Drop Over Indoor (Dry) _____	Outdoor Coil Entering Air Temp. _____
Discharge Pressure _____	Suction Pressure _____	Refrigerant Charge Checked? <input type="checkbox"/>
Refrigerant Lines: - Leak Checked? <input type="checkbox"/>	Properly Insulated? <input type="checkbox"/>	Outdoor Fan Checked? <input type="checkbox"/>
Service Valves: - - - Fully Opened? <input type="checkbox"/>	Caps Tight? <input type="checkbox"/>	Thermostat
Voltage With Compressor Operating _____	Calibrated? <input type="checkbox"/> Properly Set? <input type="checkbox"/> Level? <input type="checkbox"/>	