



©2011 Lennox Industries Inc.
Dallas, Texas, USA



RETAIN THESE INSTRUCTIONS FOR FUTURE REFERENCE

These instructions are intended as a general guide and do not supersede local codes in any way. Consult authorities who have jurisdiction before installation.

⚠ WARNING

Improper installation, adjustment, alteration, service or maintenance can cause personal injury, loss of life, or damage to property.

Installation and service must be performed by a licensed professional installer (or equivalent) or a service agency.

⚠ IMPORTANT

The Clean Air Act of 1990 bans the intentional venting of refrigerant (CFCs, HCFCs and HFCs) as of July 1, 1992. Approved methods of recovery, recycling or reclaiming must be followed. Fines and/or incarceration may be levied for noncompliance.

⚠ IMPORTANT

This unit must be matched with an indoor coil as specified in Lennox Engineering Handbook. Coils previously charged with HCFC-22 must be flushed.

NOTICE TO INSTALLER

UNIT PLACEMENT

It is critical for proper unit operation to place outdoor unit on an elevated surface as described in *Unit Placement* section on page 7.

BRAZING LINE SET TO SERVICE VALVES

It is imperative to follow the brazing technique illustrated starting on page 11 to avoid damaging the service valve's internal seals.

INSTALLATION INSTRUCTIONS

Merit® Series 14ACX Units

CONDENSING UNITS
506645-01
07/11
Supersedes 11/10

TP Technical
Publications
Litho U.S.A.

TABLE OF CONTENTS

Shipping and Packing List 1
 General 1
 Unit Dimensions 2
 Typical Unit Parts Arrangement 3
 Model Number Identification 3
 Operating Manifold Gauge Set and Service Valves ... 4
 Recovering Refrigerant from Existing System 6
 New Unit Placement 7
 Removing and Installing Louvers 8
 New or Replacement Line Set 9
 Brazing Connections 11
 Flushing Line Set and Indoor Coil 14
 Installing Indoor Metering Device 15
 Leak Test Line Set and Indoor Coil 16
 Evacuating Line Set and Indoor Coil 17
 Electrical Connections 18
 Servicing Unit Delivered Void of Charge 22
 Unit Start-Up 22
 System Refrigerant 22
 System Operation 28
 Maintenance 28
 Start-Up and Performance Checklist 30

Shipping and Packing List

Check the unit for shipping damage and listed times below are intact. If damaged, or if parts are missing, immediately contact the last shipping carrier.

- 1 — Assembled outdoor unit
- 1 — Refrigerant flow control kit (fixed orifice)
- 1 — Liquid line filter drier

General

14ACX Air Conditioners, which will also be referred to in this instruction as the outdoor unit, uses HFC-410A refrigerant. This outdoor unit must be installed with a matching indoor unit and line set as outlined in the *Lennox 14ACX Engineering Handbook*.

This outdoor unit is designed for use in systems that use one of the following refrigerant metering devices:

- Thermal expansion valve (TXV)
- Fixed orifice



Unit Dimensions - Inches (mm)

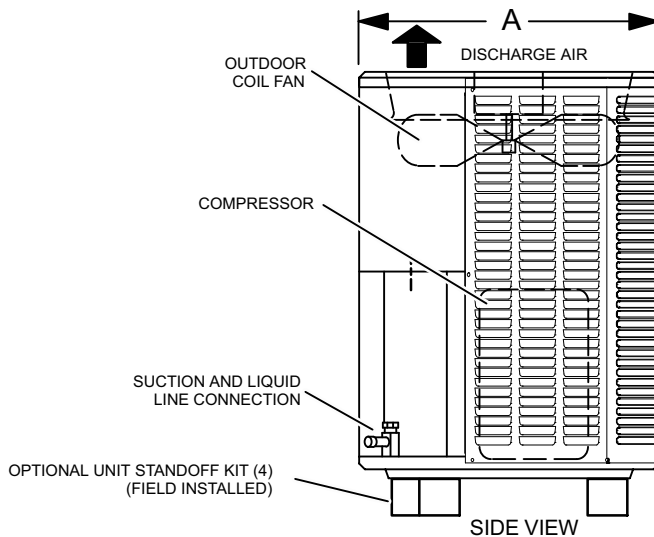
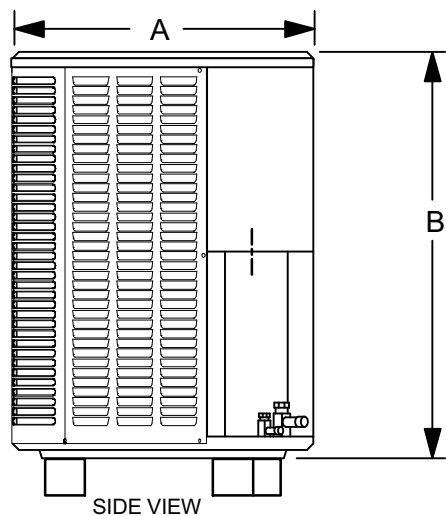

Model Numbers	A	B
14ACX-018-230	24-1/4 (616)	29-1/4 (743)
14ACX-024-230	28-1/4 (724)	33-1/4 (845)
14ACX-030-230	28-1/4 (724)	37-1/4 (946)
14ACX-036-230	28-1/4 (724)	37-1/4 (946)
14ACX-042-230	28-1/4 (724)	29-1/4 (743)
14ACX-041-230 and 14ACX-048-230	28-1/4 (724)	37-1/4 (946)
14ACX-059-230	32-1/4 (819)	37-1/4 (946)
14ACX-047-230 and 14ACX-060-230	32-1/4 (819)	33-1/4 (845)

Typical Unit Parts Arrangement

NOTE — Plumbing layout and compressor type may vary between model sizes.

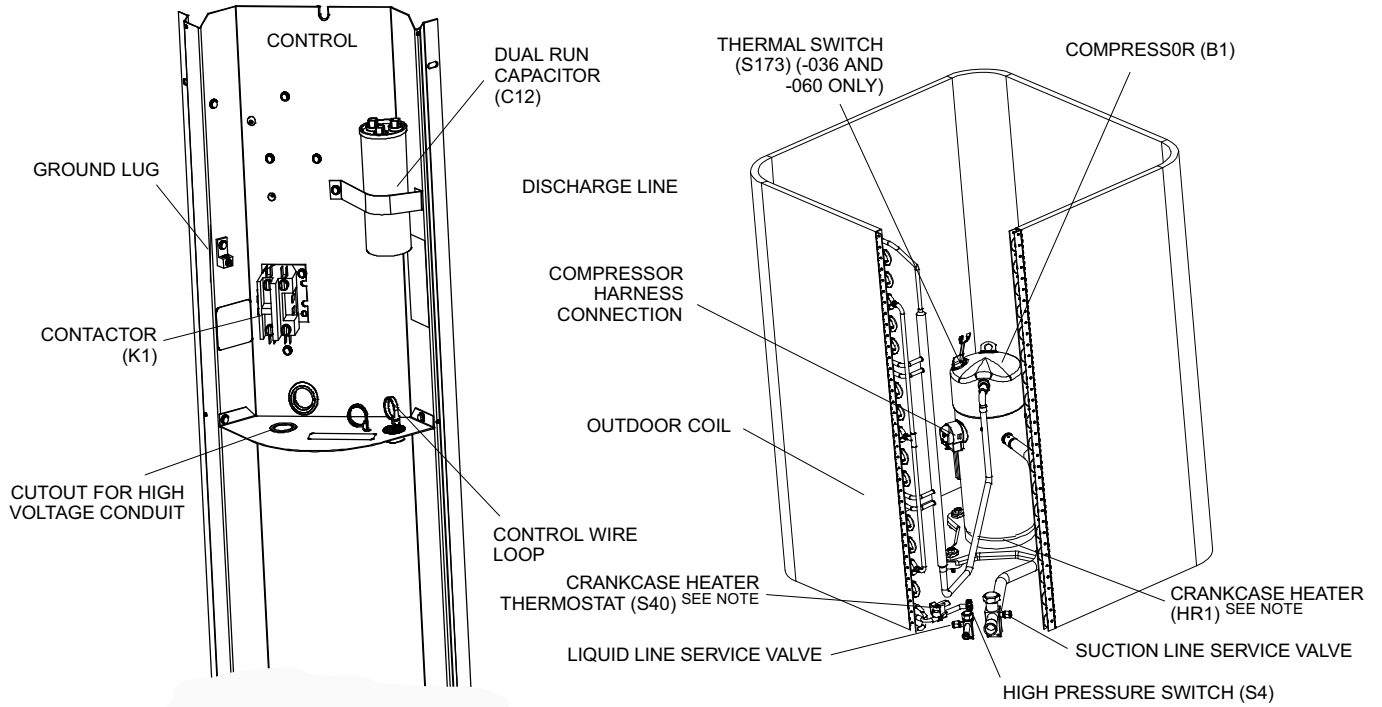

NOTE — -041, -047, -048, -059 and -060 only are equipped with crankcase thermostat (S40) and crankcase heater (HR1).

Figure 1. Typical Unit Parts Arrangement

Model Number Identification

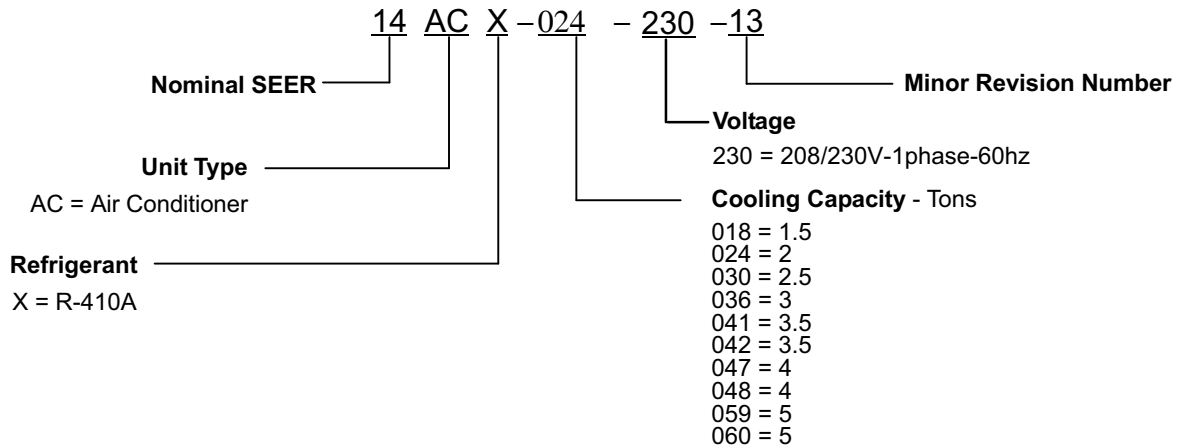

CAUTION

Physical contact with metal edges and corners while applying excessive force or rapid motion can result in personal injury. Be aware of, and use caution when working near these areas during installation or while servicing this equipment.

Operating Manifold Gauge Set and Service Valves

These instructions are intended as a general guide and do not supersede local codes in any way. Consult authorities who have jurisdiction before installation.

TORQUE REQUIREMENTS

When servicing or repairing heating, ventilating, and air conditioning components, ensure the fasteners are appropriately tightened. Table 1 lists torque values for fasteners.

IMPORTANT

Only use Allen wrenches of sufficient hardness (50Rc - Rockwell Harness Scale minimum). Fully insert the wrench into the valve stem recess.

Service valve stems are factory-torqued (from 9 ft-lbs for small valves, to 25 ft-lbs for large valves) to prevent refrigerant loss during shipping and handling. Using an Allen wrench rated at less than 50Rc risks rounding or breaking off the wrench, or stripping the valve stem recess.

See the Lennox Service and Application Notes #C-08-1 for further details and information.

IMPORTANT

To prevent stripping of the various caps used, the appropriately sized wrench should be used and fitted snugly over the cap before tightening.

When servicing or repairing HVAC components, ensure the fasteners are appropriately tightened. Table 1 provides torque values for fasteners.

Table 1. Torque Requirements

Parts	Recommended Torque	
Service valve cap	8 ft.- lb.	11 NM
Sheet metal screws	16 in.- lb.	2 NM
Machine screws #10	28 in.- lb.	3 NM
Compressor bolts	90 in.- lb.	10 NM
Gauge port seal cap	8 ft.- lb.	11 NM

USING MANIFOLD GAUGE SET

When checking the system charge, only use a manifold gauge set that features low loss anti-blow back fittings.

Manifold gauge set used with HFC-410A refrigerant systems must be capable of handling the higher system operating pressures. The gauges should be rated for use with pressures of 0 - 800 psig on the high side and a low side of 30" vacuum to 250 psig with dampened speed to 500 psi. Gauge hoses must be rated for use at up to 800 psig of pressure with a 4000 psig burst rating.

OPERATING SERVICE VALVES

The liquid and vapor line service valves are used for removing refrigerant, flushing, leak testing, evacuating, checking charge and charging.

Each valve is equipped with a service port which has a factory-installed valve stem. Figure 2 provides information on how to access and operating both angle and ball service valves.

Operating Angle Type Service Valve:

1. Remove stem cap with an appropriately sized wrench.
2. Use a service wrench with a hex-head extension (3/16" for liquid line valve sizes and 5/16" for vapor line valve sizes) to back the stem out counterclockwise as far as it will go.

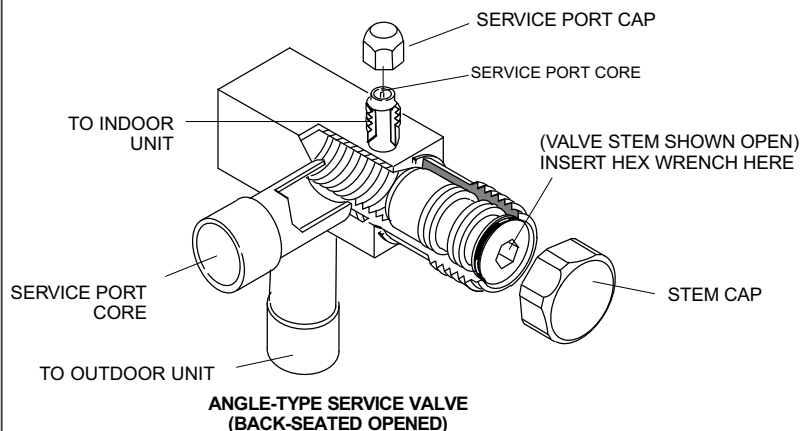

When service valve is **OPEN**, the service port is open to line set, indoor and outdoor unit.

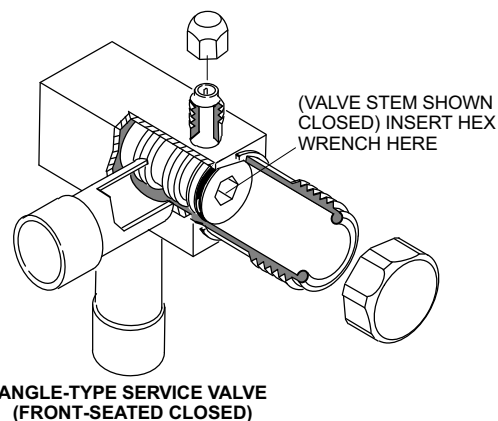

WHEN SERVICE VALVE IS **CLOSED**, THE SERVICE PORT IS OPEN TO THE LINE SET AND INDOOR UNIT.

Operating Ball Type Service Valve:

1. Remove stem cap with an appropriately sized wrench.
2. Use an appropriately sized wrench to open. To open valve, rotate stem counterclockwise 90°. To close rotate stem clockwise 90°.

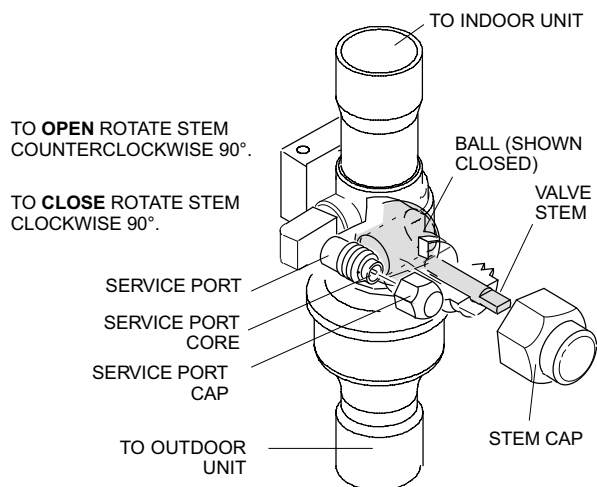

To Access Service Port:

A service port cap protects the service port core from contamination and serves as the primary leak seal.

1. Remove service port cap with an appropriately sized wrench.
2. Connect gauge set to service port.
3. When testing is completed, replace service port cap and tighten as follows:

- With torque wrench: Finger tighten and torque cap per table 1.
- Without torque wrench: Finger tighten and use an appropriately sized wrench to turn an additional 1/6 turn clockwise.

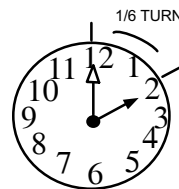

Reinstall Stem Cap:

Stem cap protects the valve stem from damage and serves as the primary seal. Replace the stem cap and tighten as follows:

- With Torque Wrench: Finger tighten and then torque cap per table 1.
- Without Torque Wrench: Finger tighten and use an appropriately sized wrench to turn an additional 1/12 turn clockwise.

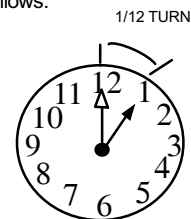

NOTE — A label with specific torque requirements may be affixed to the stem cap. If the label is present, use the specified torque.

Figure 2. Angle and Ball Service Valves

Recovering Refrigerant from Existing System

Use the following procedure to recover refrigerant from an existing system (indoor coil, line set and outdoor unit).

1 DISCONNECT POWER

Disconnect all power to the existing outdoor unit at the service disconnect switch or main fuse box/breaker panel.

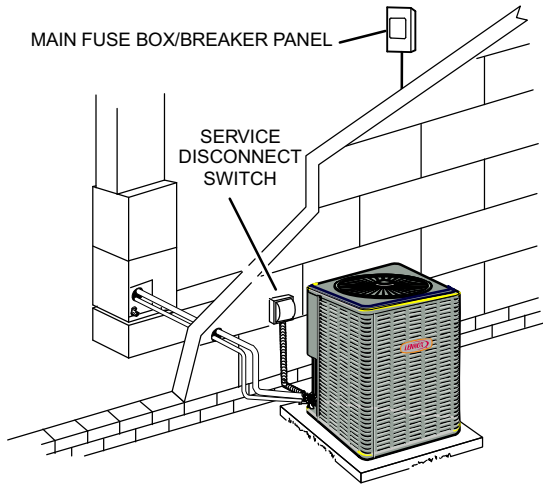

2 CONNECT MANIFOLD GAUGE SET

Connect a gauge set, clean recovery cylinder and a recovery machine to the service ports of the existing unit. Use the instructions provided with the recovery machine to make the connections.

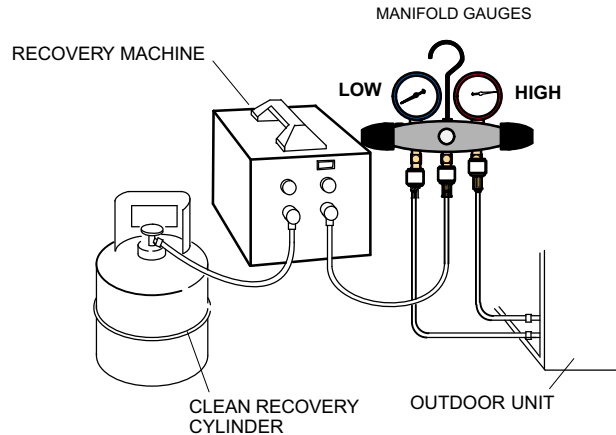

3 RECOVERING REFRIGERANT

Remove existing HCFC-22 refrigerant using one of the following procedures:

IMPORTANT — Some system configurations may contain higher than normal refrigerant charge due to either large internal coil volumes, and/or long line sets.

METHOD 1:

Use this method if the existing outdoor unit is not equipped with shut-off valves, or if the unit is not operational and you plan to use the existing HCFC-22 to flush the system.

Remove all HCFC-22 refrigerant from the existing system. Check gauges after shutdown to confirm that the entire system is completely void of refrigerant.

METHOD 2:

Use this method if the existing outdoor unit is equipped with manual shut-off valves, and you plan to use new HCFC-22 refrigerant to flush the system.

The following devices could prevent full system charge recovery into the outdoor unit:

- Outdoor unit's high or low-pressure switches (if applicable) when tripped can cycle the compressor **OFF**.
- Compressor can stop pumping due to tripped internal pressure relief valve.
- Compressor has internal vacuum protection that is designed to unload the scrolls (compressor stops pumping) when the pressure ratio meets a certain value or when the suction pressure is as high as 20 psig. (Compressor suction pressures should never be allowed to go into a vacuum. Prolonged operation at low suction pressures will result in overheating of the scrolls and permanent damage to the scroll tips, drive bearings and internal seals.)

Once the compressor can not pump down to a lower pressure due to one of the above system conditions, shut off the vapor valve. Turn OFF the main power to unit and use a recovery machine to recover any refrigerant left in the indoor coil and line set.

Perform the following task:

- A Start the existing HCFC-22 system in the cooling mode and close the liquid line valve.
- B Use the compressor to pump as much of the existing HCFC-22 refrigerant into the outdoor unit until the outdoor system is full. Turn the outdoor unit main power OFF and use a recovery machine to remove the remaining refrigerant from the system.

NOTE — It may be necessary to bypass the low pressure switches (if equipped) to ensure complete refrigerant evacuation.

- C When the low side system pressures reach 0 psig, close the vapor line valve.
- D Check gauges after shutdown to confirm that the valves are not allowing refrigerant to flow back into the low side of the system.

Figure 3. Refrigerant Recovery Procedure

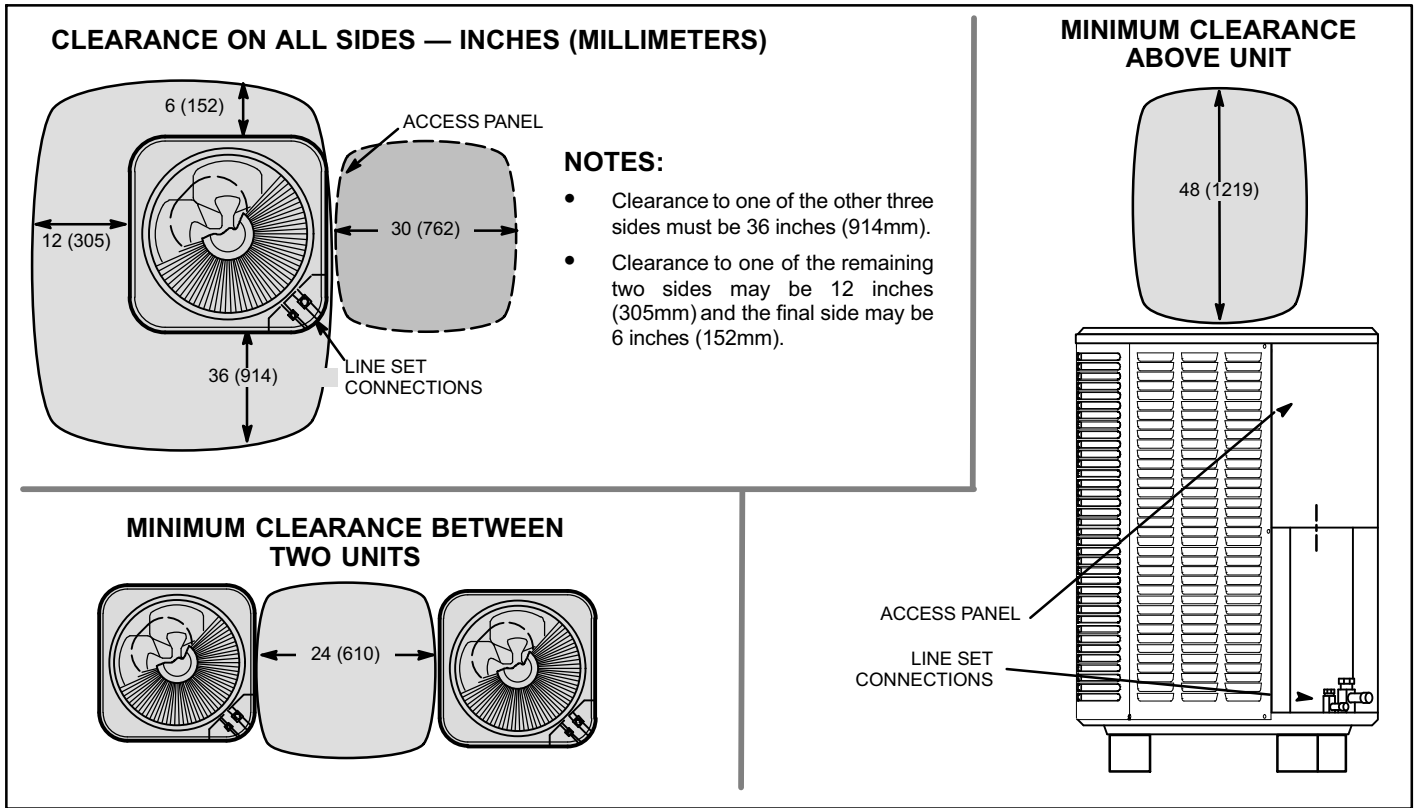

Figure 4. Installation Clearances

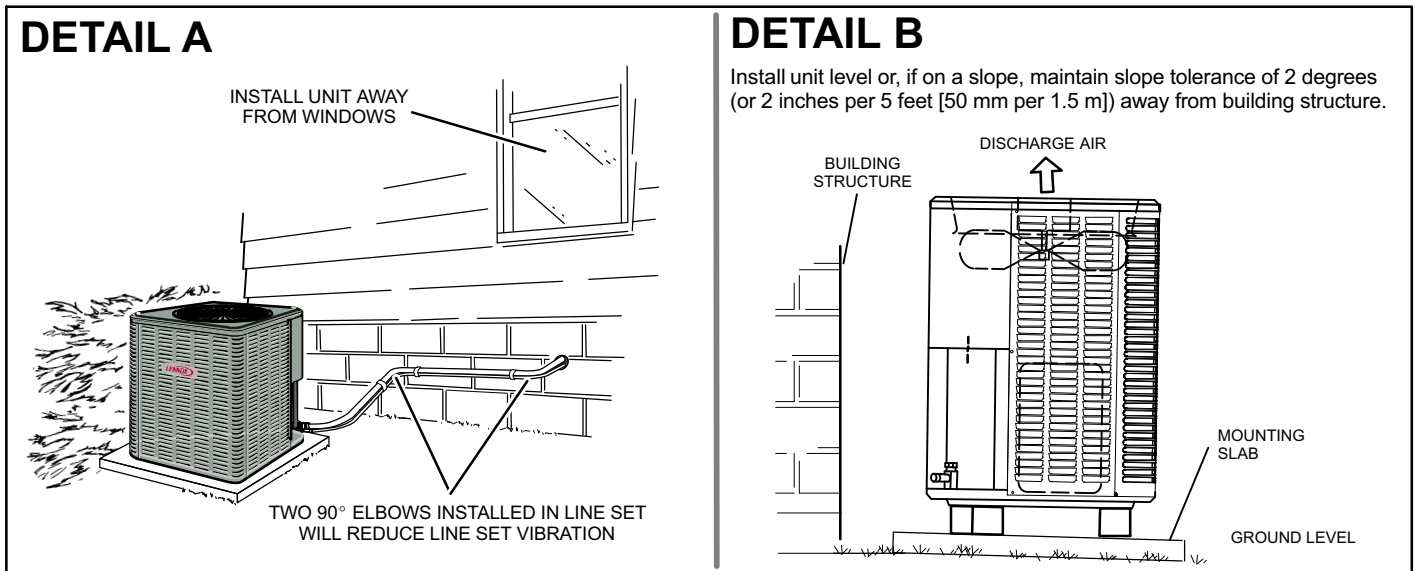

Figure 5. Placement, and Slab Mounting

New Unit Placement

See *Unit Dimensions* on page 2 for sizing mounting slab, platforms or supports. Refer to figure 4 for mandatory installation clearance requirements.

POSITIONING CONSIDERATIONS

⚠ CAUTION

In order to avoid injury, take proper precaution when lifting heavy objects.

Consider the following when positioning the unit:

- Some localities are adopting sound ordinances based on the unit's sound level registered from the adjacent property, not from the installation property. Install the unit as far as possible from the property line.
- When possible, do not install the unit directly outside a window. Glass has a very high level of sound transmission. For proper placement of unit in relation to a window see the provided illustration in figure 5, detail A.

PLACING UNIT ON SLAB

When installing unit at grade level, the top of the slab should be high enough above grade so that water from higher ground will not collect around the unit. The slab should have a slope tolerance as described in figure 5, detail B.

ROOF MOUNTING

Install the unit at a minimum of 4 inches (102 mm) above the surface of the roof. Ensure the weight of the unit is properly distributed over roof joists and rafters. Redwood or steel supports are recommended.

NOTICE

Roof Damage!

This system contains both refrigerant and oil. Some rubber roofing material may absorb oil and cause the rubber to swell when it comes into contact with oil. The rubber will then bubble and could cause leaks. Protect the roof surface to avoid exposure to refrigerant and oil during service and installation. Failure to follow this notice could result in damage to roof surface.

Removing and Installing Louvers



WARNING

To prevent personal injury, or damage to panels, unit or structure, be sure to observe the following:

While installing or servicing this unit, carefully stow all removed panels out of the way, so that the panels will not cause injury to personnel, nor cause damage to objects or structures nearby, nor will the panels be subjected to damage (e.g., being bent or scratched).

While handling or stowing the panels, consider any weather conditions, especially windy conditions, that may cause panels to be blown around and battered.

When removing the unit panels. Remove panel **A** first, then **B**, **C** and finally **D**. When reinstalling panels, reverse that order starting with panel **D**, **C**, **B** and finally **A**.

REMOVAL

STEP 1

TO REMOVE PANEL, REMOVE MOUNTING SCREWS SECURING PANEL TO THE UNIT.

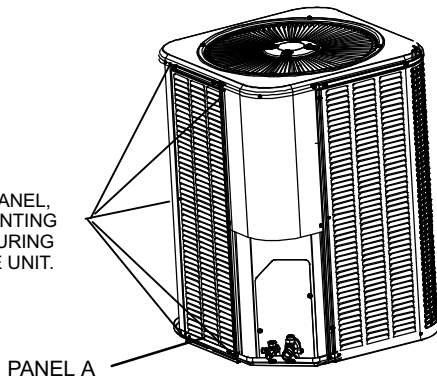

STEP 2

SLIGHTLY LIFT PANEL **A** IN ORDER TO CLEAR SIDE LIPS OF PANEL FROM BASE OF UNIT.

STEP 3

TILT PANEL OUT SLIGHTLY AND PULL DOWNWARD TO REMOVE.

REPEAT STEPS 1, 2 AND 3 TO REMOVE PANELS **B**, **C** AND FINALLY **D**.

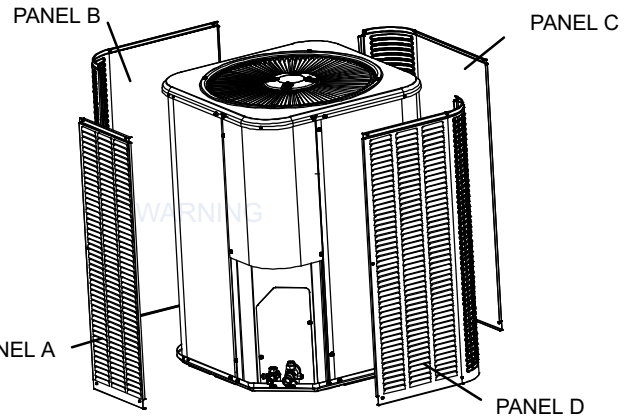
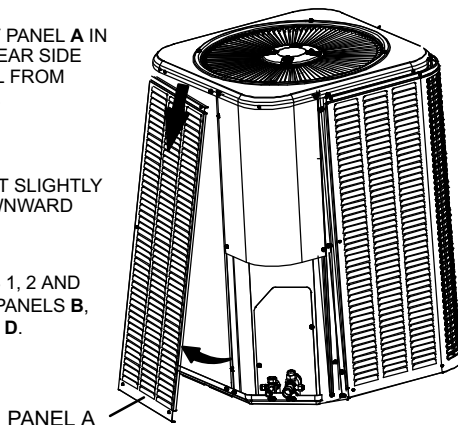

INSTALLATION

STEP 1

STARTING WITH PANEL **D**, INSERT PANEL UNDER UNIT TOP CAP LIP AND LIFT SLIGHTLY TO CLEAR SIDE LIP OF PANEL FROM BASE.

STEP 2

MOVE PANEL IN TOWARDS UNIT. ALIGN LEFT/RIGHT SIDE LIPS OF PANEL WITH GROOVE INSERTS ALONG LEFT/RIGHT SIDE OF UNIT.

STEP 3

SECURE PANEL, WITH MOUNTING SCREWS.

REPEAT STEPS 1 AND 2 TO INSTALL PANELS **C**, **B** AND FINALLY **A**.

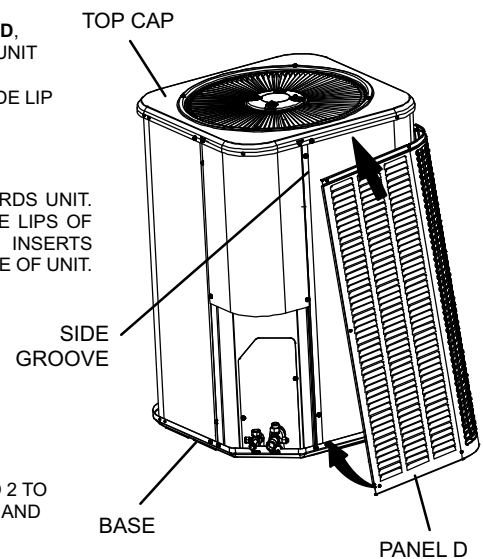

Figure 6. Louvers

New or Replacement Line Set

This section provides information on new installation or replacement of existing line set. If a new or replacement line set is not required, then proceed to *Brazing Connections* on page 11.

Field refrigerant piping consists of liquid and suction lines from the outdoor unit (braze connections) to the indoor unit coil (flare or braze connections). Use Lennox L15 (braze, non-flare) series line set, or use field-fabricated refrigerant lines as listed in table 2.

NOTE - When installing refrigerant lines longer than 50 feet, see the Lennox Refrigerant Piping Design and Fabrication Guidelines, CORP. 9351-L9, or contact Lennox Technical Support Product Applications for assistance.

To obtain the correct information from Lennox, be sure to communicate the following points:

- Model (14ACX) and size of unit (e.g. -060).
- Line set diameters for the unit being installed as listed in table 2 and total length of installation.
- Number of elbows and if there is a rise or drop of the piping.

If refrigerant lines are routed through a wall, seal and isolate the opening so vibration is not transmitted to the building. Pay close attention to line set isolation during installation of any HVAC system. When properly isolated from building structures (walls, ceilings, floors), the refrigerant lines will not create unnecessary vibration and subsequent sounds.

⚠ IMPORTANT

Mineral oils are not compatible with HFC-410A. If oil must be added, it must be a Polyol ester oil.

The compressor is charged with sufficient Polyol ester oil for line set lengths up to 50 feet. Recommend adding oil to system based on the amount of refrigerant charge in the system. No need to add oil in system with 20 pounds of refrigerant or less. For systems over 20 pounds - add one ounce of every five pounds of refrigerant.

Recommended topping-off POE oils are Mobil EAL ARCTIC 22 CC or ICI EMKARATE™ RL32CF.

MATCHING WITH NEW OR EXISTING INDOOR COIL AND LINE SET

The RFC1-metering line consisted of a small bore copper line that ran from condenser to evaporator coil. Refrigerant was metered into the evaporator by utilizing temperature/pressure evaporation effects on refrigerant in the small RFC line. The length and bore of the RFC line corresponded to the size of cooling unit.

If the 14ACX is being used with either a new or existing indoor coil which is equipped with a liquid line which served as a metering device (RFCI), the liquid line must be replaced prior to the installation of the 14ACX unit. Typically a liquid line used to meter flow is 1/4" in diameter and copper.

LIQUID LINE FILTER DRIER INSTALLATION

The filter drier (one is shipped with each 14ACX unit) must be field installed in the liquid line between the outdoor unit's liquid line service valve and the indoor coil's metering device (fixed orifice or TXV) as illustrated in figure 7. This filter drier must be installed to ensure a clean, moisture-free system. Failure to install the filter drier will void the warranty. A replacement filter drier is available from Lennox. See *Brazing Connections* page 11 for special procedures on brazing filter drier connections to the liquid line.

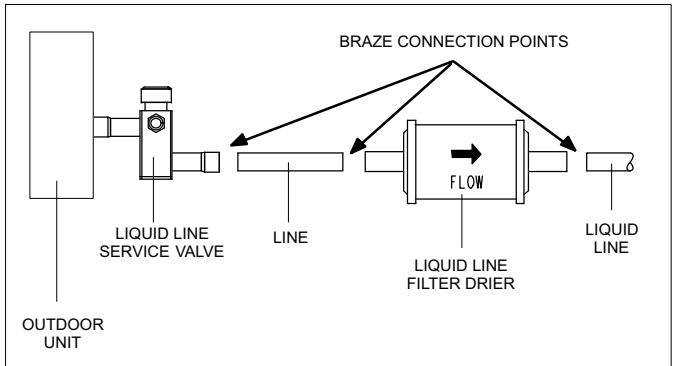

Figure 7. Typical Liquid Line Filter Drier Installation

Table 2. Refrigerant Line Set — Inches (mm)

Model Number	Valve Field Size Connections		Recommended Line Set		
	Liquid Line	Suction Line	Liquid Line	Suction Line	L15 Series Line Sets
14ACX-018-230	3/8 in. (10 mm)	3/4 in. (19 mm)	3/8 in. (10 mm)	3/4 in. (19 mm)	L15-41 — 15 feet to 50 feet (4.6 meters to 15 meters)
14ACX-024-230					
14ACX-030-230					
14ACX-036-230	3/8 in. (10 mm)	7/8 in. (22 mm)	3/8 in. (10 mm)	7/8 in. (22 mm)	L15-65 — 15 feet to 50 feet (4.6 meters to 15 meters)
14ACX-041-230					
14ACX-042-230					
14ACX-047-230					
14ACX-048-230					
14ACX-059-230	3/8 in. (10 mm)	1-1/8 in. (29 mm)	3/8 in. (10 mm)	1-1/8 in. (29 mm)	Field Fabricated
14ACX-060-230					

NOTE — Some applications may require a field provided 7/8" to 1-1/8" adapter

LINE SET

IMPORTANT — Refrigerant lines must not contact structure.

INSTALLATION

Line Set Isolation — The following illustrations are examples of proper refrigerant line set isolation:

REFRIGERANT LINE SET — TRANSITION FROM VERTICAL TO HORIZONTAL

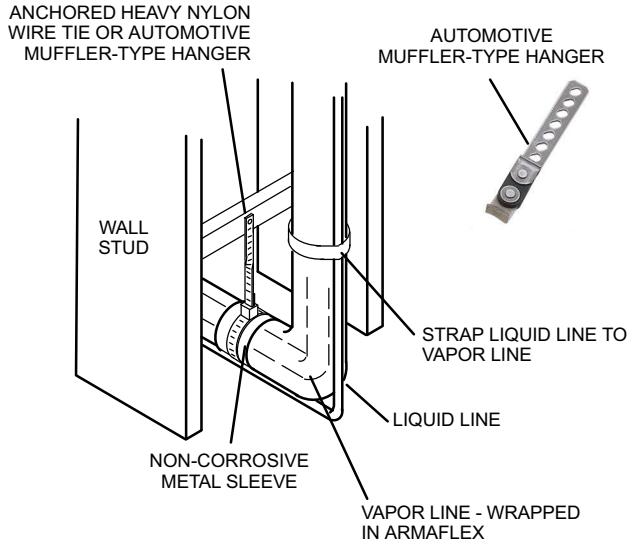

REFRIGERANT LINE SET — INSTALLING VERTICAL RUNS (NEW CONSTRUCTION SHOWN)

NOTE — Insulate liquid line when it is routed through areas where the surrounding ambient temperature could become higher than the temperature of the liquid line or when pressure drop is equal to or greater than 20 psig.

IMPORTANT — Refrigerant lines must not contact wall

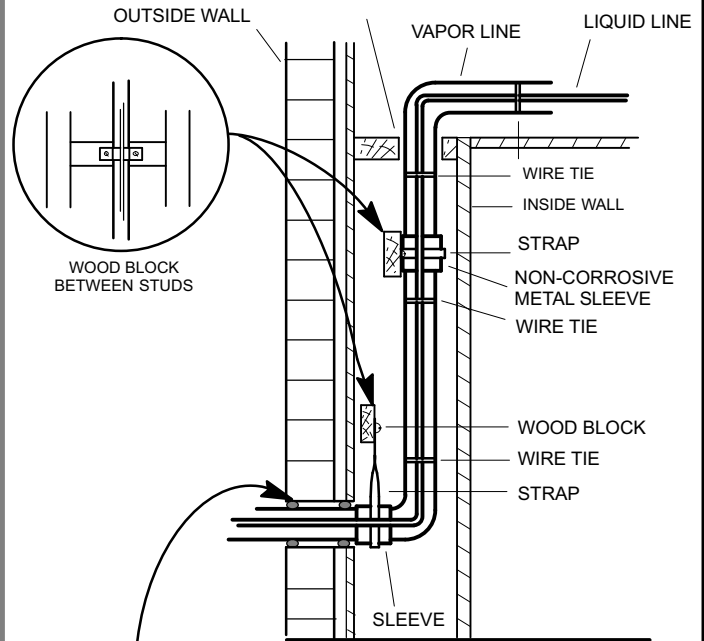

REFRIGERANT LINE SET — INSTALLING HORIZONTAL RUNS

To hang line set from joist or rafter, use either metal strapping material or anchored heavy nylon wire ties.

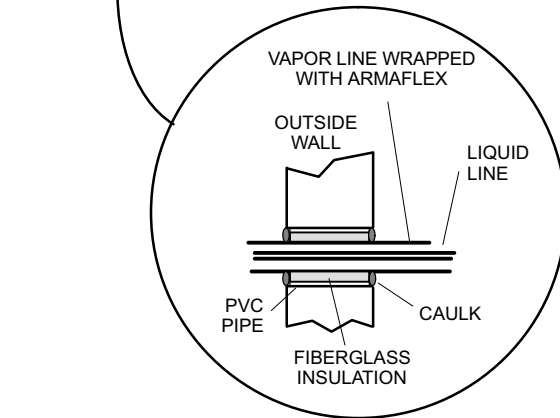
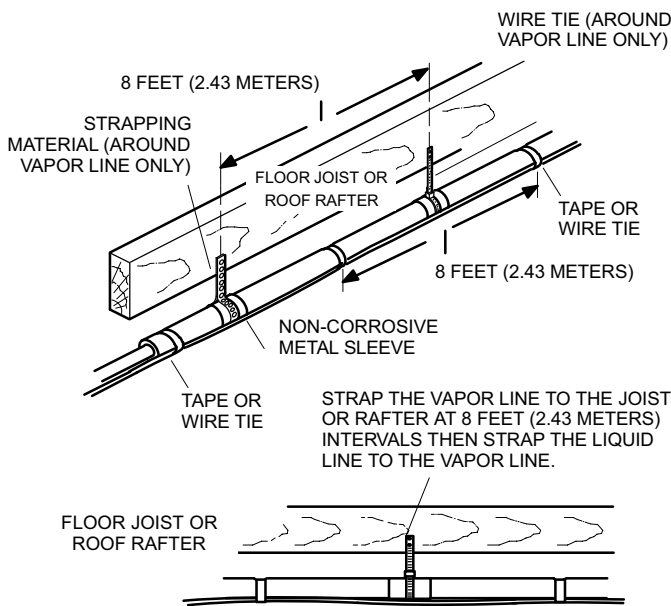

NOTE — Similar installation practices should be used if line set is to be installed on exterior of outside wall.

Figure 8. Line Set Installation Guidelines

Brazing Connections

Use the procedures outline in figures 9 and 10 for brazing line set connections to service valves.

IMPORTANT

Polyol ester (POE) oils used with HFC-410A refrigerant absorb moisture very quickly. It is very important that the refrigerant system be kept closed as much as possible. **DO NOT** remove line set caps or service valve stub caps until you are ready to make connections.

WARNING



Danger of fire. Bleeding the refrigerant charge from only the high side may result in pressurization of the low side shell and suction tubing. Application of a brazing torch to a pressurized system may result in ignition of the refrigerant and oil mixture - Check the high and low pressures before applying heat.

WARNING



When using a high pressure gas such as dry nitrogen to pressurize a refrigeration or air conditioning system, use a regulator that can control the pressure down to 1 or 2 psig (6.9 to 13.8 kPa).

CAUTION

Brazing alloys and flux contain materials which are hazardous to your health.

Avoid breathing vapors or fumes from brazing operations. Perform operations only in well-ventilated areas.

Wear gloves and protective goggles or face shield to protect against burns.

Wash hands with soap and water after handling brazing alloys and flux.

IMPORTANT

Connect gauge set low pressure side to vapor line service valve and repeat procedure starting at paragraph 4 for brazing the liquid line to service port valve.

IMPORTANT

Allow braze joint to cool before removing the wet rag from the service valve. Temperatures above 250°F can damage valve seals.

IMPORTANT

Use silver alloy brazing rods with 5% minimum silver alloy for copper-to-copper brazing. Use 45% minimum alloy for copper-to-brass and copper-to-steel brazing.

WARNING



Fire, Explosion and Personal Safety Hazard.

Failure to follow this warning could result in damage, personal injury or death.

Never use oxygen to pressurize or purge refrigeration lines. Oxygen, when exposed to a spark or open flame, can cause fire and/or an explosion, that could result in property damage, personal injury or death.

1 CUT AND DEBUR

Cut ends of the refrigerant lines square (free from nicks or dents) and debur the ends. The pipe must remain round. Do not crimp end of the line.

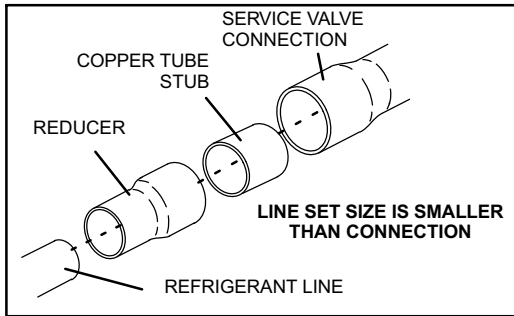
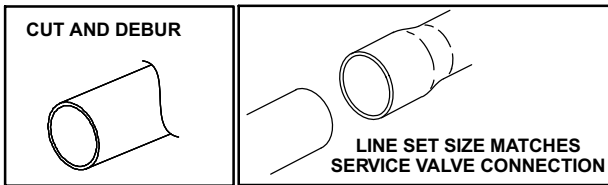

DO NOT CRIMP SERVICE VALVE CONNECTOR WHEN PIPE IS SMALLER THAN CONNECTION

2 CAP AND CORE REMOVAL

Remove service cap and core from both the suction / vapor and liquid line service ports.

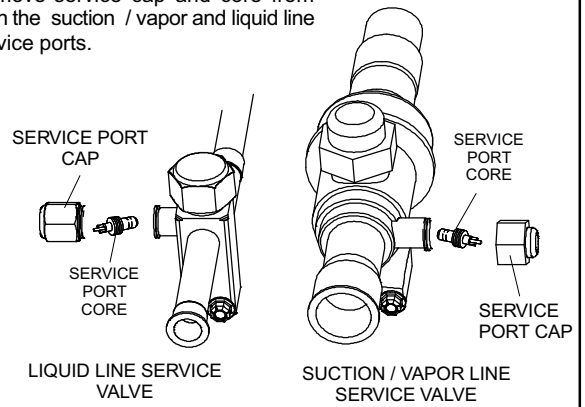

3 ATTACH THE MANIFOLD GAUGE SET FOR BRAZING LIQUID AND SUCTION / VAPOR LINE SERVICE VALVES

Flow regulated nitrogen (at 1 to 2 psig) through the low-side refrigeration gauge set into the liquid line service port valve, and out of the suction / vapor line service port valve.

- A Connect gauge set low pressure side to liquid line service valve (service port).
- B Connect gauge set center port to bottle of nitrogen with regulator.
- C Remove core from valve in suction / vapor line service port to allow nitrogen to escape.

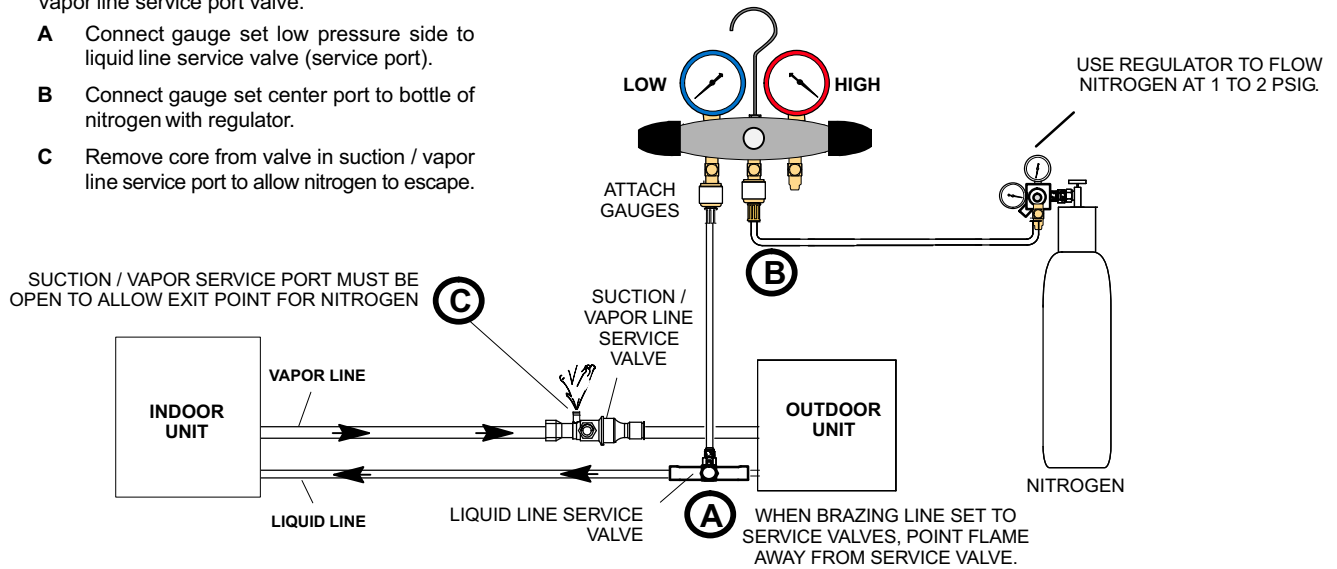

WHEN BRAZING LINE SET TO SERVICE VALVES, POINT FLAME AWAY FROM SERVICE VALVE.

Figure 9. Brazing Procedures

4 WRAP SERVICE VALVES

To help protect service valve seals during brazing, wrap water saturated cloths around service valve bodies and copper tube stubs. Use additional water saturated cloths underneath the valve body to protect the base paint.

5 FLOW NITROGEN

Flow regulated nitrogen (at 1 to 2 psig) through the refrigeration gauge set into the valve stem port connection on the liquid service valve and out of the suction / vapor valve stem port. See steps **3A**, **3B** and **3C** on manifold gauge set connections

6 BRAZE LINE SET

Wrap both service valves with water saturated cloths as illustrated here and as mentioned in step 4, before brazing to line set. Water saturated cloths must remain water saturated throughout the brazing and cool-down process.

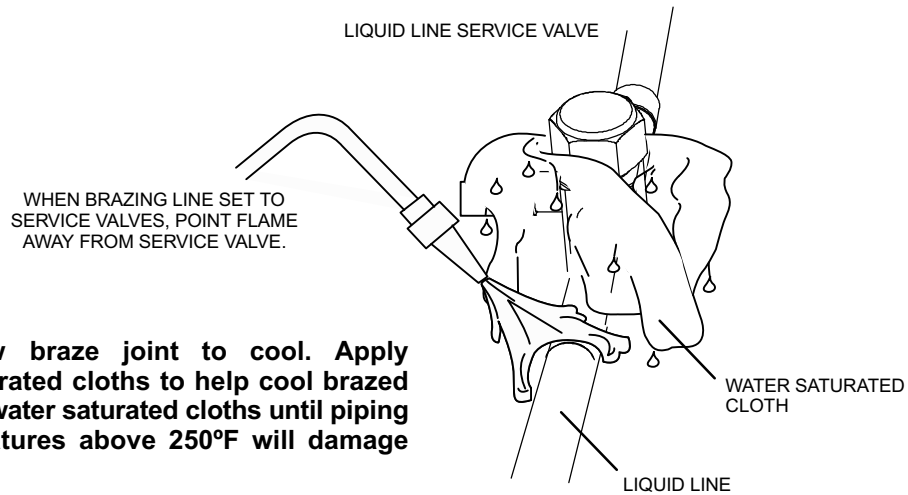

IMPORTANT — Allow braze joint to cool. Apply additional water saturated cloths to help cool brazed joint. Do not remove water saturated cloths until piping has cooled. Temperatures above 250°F will damage valve seals.

WARNING

- 1. FIRE, PERSONAL INJURY, OR PROPERTY DAMAGE** will result if you do not wrap a water saturated cloth around both liquid and suction line service valve bodies and copper tube stub while brazing in the line set! The braze, when complete, must be quenched with water to absorb any residual heat.
- 2. Do not open service valves until refrigerant lines and indoor coil have been leak-tested and evacuated. Refer to procedures provided in this supplement.**

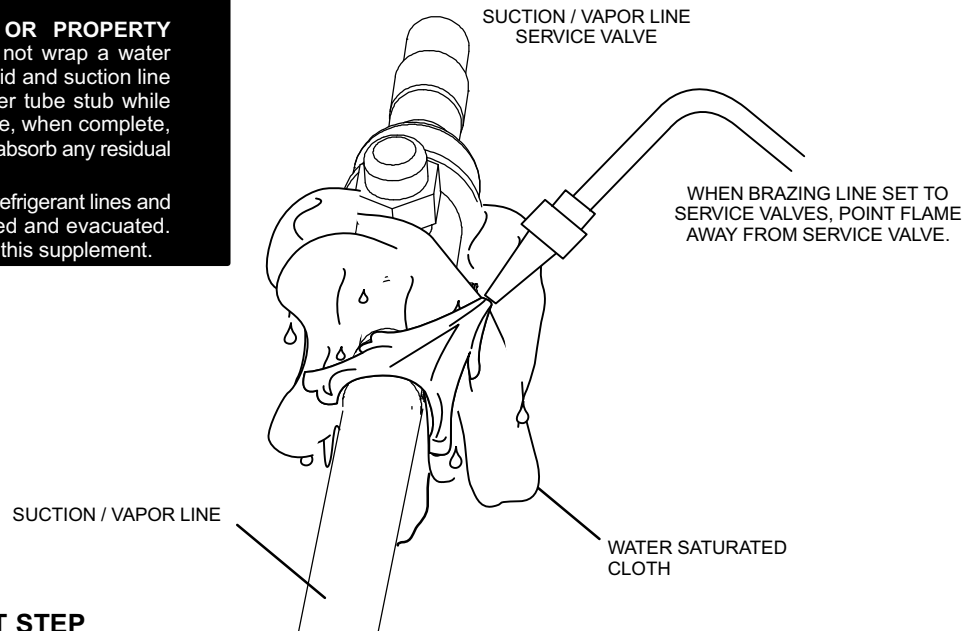

7 PREPARATION FOR NEXT STEP

After all connections have been brazed, disconnect manifold gauge set from service ports. Apply additional water saturated cloths to both services valves to cool piping. Once piping is cool, remove all water saturated cloths. Refer to the unit installation instructions for the next step in preparing the unit.

Figure 10. Brazing Procedures (continued)

Flushing Line Set and Indoor Coil

Flushing is only required if existing indoor coil and line set are to be used. Otherwise proceed to *Installing Indoor Metering Device* on page 15.

1A TYPICAL EXISTING FIXED ORIFICE REMOVAL PROCEDURE (UNCASED COIL SHOWN)

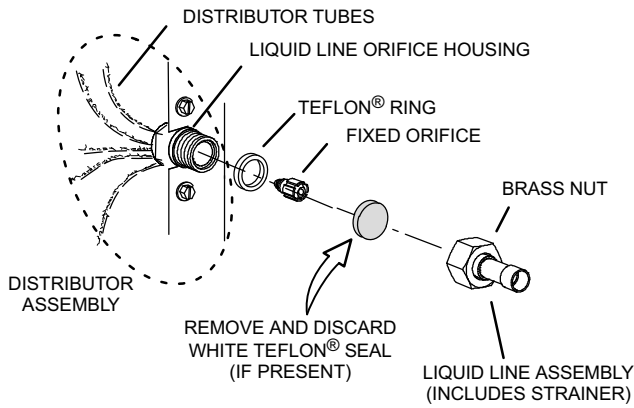

- A** On fully cased coils, remove the coil access and plumbing panels.
- B** Remove any shipping clamps holding the liquid line and distributor assembly.
- C** Using two wrenches, disconnect liquid line from liquid line orifice housing. Take care not to twist or damage distributor tubes during this process.
- D** Remove and discard fixed orifice, valve stem assembly if present and Teflon® washer as illustrated above.
- E** Use a field-provided fitting to temporary reconnect the liquid line to the indoor unit's liquid line orifice housing.

1B TYPICAL EXISTING EXPANSION VALVE REMOVAL PROCEDURE (UNCASED COIL SHOWN)

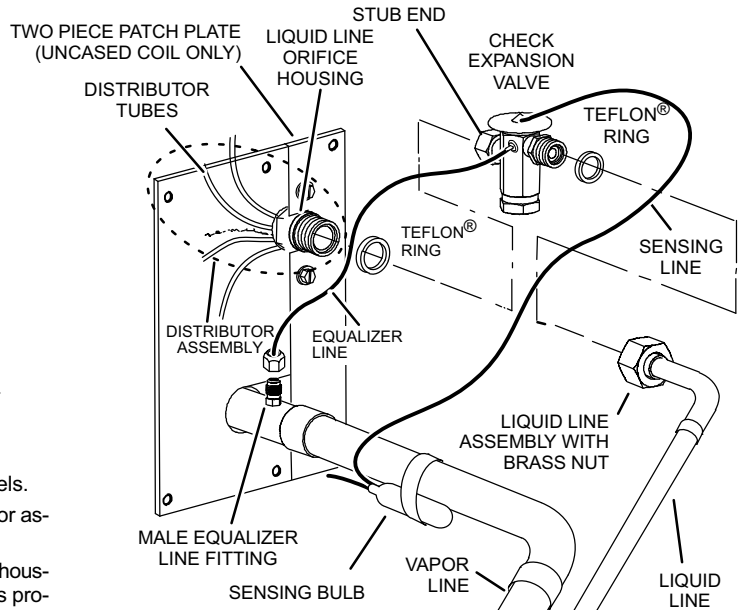

- A** On fully cased coils, remove the coil access and plumbing panels.
- B** Remove any shipping clamps holding the liquid line and distributor assembly.
- C** Disconnect the equalizer line from the check expansion valve equalizer line fitting on the vapor line.
- D** Remove the vapor line sensing bulb.
- E** Disconnect the liquid line from the check expansion valve at the liquid line assembly.
- F** Disconnect the check expansion valve from the liquid line orifice housing. Take care not to twist or damage distributor tubes during this process.
- G** Remove and discard check expansion valve and the two Teflon® rings.
- H** Use a field-provided fitting to temporary reconnect the liquid line to the indoor unit's liquid line orifice housing.

2 CONNECT GAUGES AND EQUIPMENT FOR FLUSHING PROCEDURE

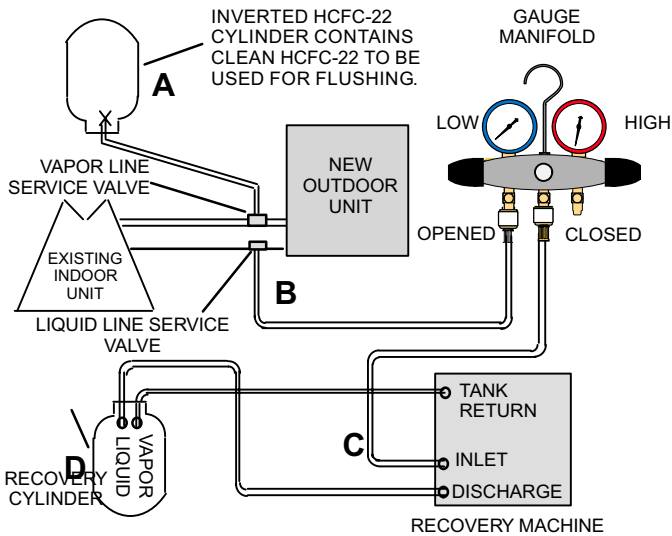

- A** Inverted HCFC-22 cylinder with clean refrigerant to the vapor service valve.
- B** HCFC-22 gauge set (low side) to the liquid line valve.
- C** HCFC-22 gauge set center port to inlet on the recovery machine with an empty recovery tank to the gauge set.
- D** Connect recovery tank to recovery machines per machine instructions.

3 FLUSHING LINE SET

The line set and indoor unit coil must be flushed with at least the same amount of clean refrigerant that previously charged the system. Check the charge in the flushing cylinder before proceeding.

- A** Set the recovery machine for liquid recovery and start the recovery machine. Open the gauge set valves to allow the recovery machine to pull a vacuum on the existing system line set and indoor unit coil.
- B** Invert the cylinder of clean HCFC-22 and open its valve to allow liquid refrigerant to flow into the system through the vapor line valve. Allow the refrigerant to pass from the cylinder and through the line set and the indoor unit coil before it enters the recovery machine.
- C** After all of the liquid refrigerant has been recovered, switch the recovery machine to vapor recovery so that all of the HCFC-22 vapor is recovered. Allow the recovery machine to pull down to 0 the system.
- D** Close the valve on the inverted HCFC-22 drum and the gauge set valves. Pump the remaining refrigerant out of the recovery machine and turn the machine off.

Figure 11. Removing Metering Device and Flushing

Installing Indoor Metering Device

This outdoor unit is designed for use in systems that use either an fixed orifice (RFC) (included with outdoor unit), or expansion valve metering device (purchased separately) at the indoor coil.

See the *Lennox 14ACX Engineering Handbook* for approved expansion valve kit match ups. The expansion valve unit can be installed internal or external to the indoor

coil. In applications where an uncased coil is being installed in a field-provided plenum, install the expansion valve in a manner that will provide access for field servicing of the expansion valve. Refer to below illustration for reference during installation of expansion valve unit. .

After installation of the indoor coil metering device, proceed to *Leak Test Line Set and Indoor Coil* on page 16.

INDOOR EXPANSION VALVE INSTALLATION

(Uncased Coil Shown)

Labels in diagram: TWO PIECE PATCH PLATE (UNCASED COIL ONLY), LIQUID LINE ORIFICE HOUSING, STUB END, EXPANSION VALVE, TEFLON® RING, SENSING LINE, DISTRIBUTOR TUBES, DISTRIBUTOR ASSEMBLY, EQUALIZER LINE, LIQUID LINE ASSEMBLY WITH BRASS NUT, VAPOR LINE, LIQUID LINE, MALE EQUALIZER LINE FITTING (SEE EQUALIZER LINE INSTALLATION FOR FURTHER DETAILS).

Sensing bulb insulation is required if mounted external to the coil casing. sensing bulb installation for bulb positioning.

- A** Remove the field-provided fitting that temporary reconnected the liquid line to the indoor unit's distributor assembly.
- B** Install one of the provided Teflon® rings around the stubbed end of the expansion valve and lightly lubricate the connector threads and expose surface of the Teflon® ring with refrigerant oil.
- C** Attach the stubbed end of the expansion valve to the liquid line orifice housing. Finger tighten and use an appropriately sized wrench to turn an additional 1/2 turn clockwise as illustrated in the figure above, or 20 ft-lb.
- D** Place the remaining Teflon® washer around the other end of the expansion valve. Lightly lubricate connector threads and expose surface of the Teflon® ring with refrigerant oil.
- E** Attach the liquid line assembly to the expansion valve. Finger tighten and use an appropriately sized wrench to turn an additional 1/2 turn clockwise as illustrated in the figure above or 20 ft-lb.

1/2 Turn

EQUALIZER LINE INSTALLATION

- A** Remove and discard either the flare seal cap or flare nut with copper flare seal bonnet from the equalizer line port on the vapor line as illustrated in the figure to the right.
- B** Remove and discard either the flare seal cap or flare nut with copper flare seal bonnet from the equalizer line port on the vapor line as illustrated in the figure to the right.

Labels: FLARE SEAL CAP, FLARE NUT, COPPER FLARE SEAL BONNET, MALE BRASS EQUALIZER LINE FITTING, VAPOR LINE.

SENSING BULB INSTALLATION

- A** Attach the vapor line sensing bulb in the proper orientation as illustrated to the right using the clamp and screws provided.

NOTE — Confirm proper thermal contact between vapor line and expansion bulb before insulating the sensing bulb once installed.

- B** Connect the equalizer line from the expansion valve to the equalizer vapor port on the vapor line. Finger tighten the flare nut plus 1/8 turn (7 ft-lbs) as illustrated below.

Labels: VAPOR LINE, BULB.

ON LINES SMALLER THAN 7/8", MOUNT SENSING BULB AT EITHER THE 3 OR 9 O'CLOCK POSITION.

ON 7/8" AND LARGER LINES, MOUNT SENSING BULB AT EITHER THE 4 OR 8 O'CLOCK POSITION. NEVER MOUNT ON BOTTOM OF LINE.

NOTE — NEVER MOUNT ON BOTTOM OF LINE.

1/8 Turn

Figure 12. Installing Indoor Expansion Valve

⚠ IMPORTANT

The Environmental Protection Agency (EPA) prohibits the intentional venting of HFC refrigerants during maintenance, service, repair and disposal of appliance. Approved methods of recovery, recycling or reclaiming must be followed.

⚠ IMPORTANT

If this unit is being matched with an approved line set or indoor unit coil which was previously charged with mineral oil, or if it is being matched with a coil which was manufactured before January of 1999, the coil and line set must be flushed prior to installation. Take care to empty all existing traps. Polyol ester (POE) oils are used in Lennox units charged with HFC-410A refrigerant. Residual mineral oil can act as an insulator, preventing proper heat transfer. It can also clog the expansion device, and reduce the system performance and capacity. Failure to properly flush the system per the instructions below will void the warranty.

Leak Test Line Set and Indoor Coil

⚠ IMPORTANT

Leak detector must be capable of sensing HFC refrigerant.

After completing the leak testing the line set and indoor coil as outlined in figure 13, proceed to *Evacuating Line Set and Indoor Coil* on page 17.

⚠ WARNING



When using a high pressure gas such as dry nitrogen to pressurize a refrigeration or air conditioning system, use a regulator that can control the pressure down to 1 or 2 psig (6.9 to 13.8 kPa).

⚠ WARNING

Refrigerant can be harmful if it is inhaled. Refrigerant must be used and recovered responsibly.

Failure to follow this warning may result in personal injury or death.

1 CONNECT GAUGE SET

- A** Connect an HFC-410A manifold gauge set high pressure hose to the vapor valve service port.

NOTE — Normally, the high pressure hose is connected to the liquid line port. However, connecting it to the vapor port better protects the manifold gauge set from high pressure damage.

- B** With both manifold valves closed, connect the cylinder of HFC-410A refrigerant to the center port of the manifold gauge set.

NOTE — Later in the procedure, the HFC-410A container will be replaced by the nitrogen container.

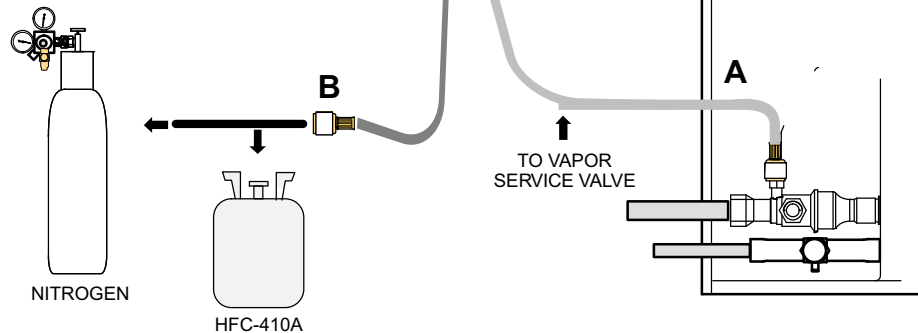

2 TEST FOR LEAKS

After the line set has been connected to the indoor and outdoor units, check the line set connections and indoor unit for leaks. Use the following procedure to test for leaks:

- A** With both manifold valves closed, connect the cylinder of HFC-410A refrigerant to the center port of the manifold gauge set. Open the valve on the HFC-410A cylinder (vapor only).
- B** Open the high pressure side of the manifold to allow HFC-410A into the line set and indoor unit. Weigh in a trace amount of HFC-410A. [A trace amount is a maximum of two ounces (57 g) refrigerant or three pounds (31 kPa) pressure]. Close the valve on the HFC-410A cylinder and the valve on the high pressure side of the manifold gauge set. Disconnect the HFC-410A cylinder.
- C** Connect a cylinder of dry nitrogen with a pressure regulating valve to the center port of the manifold gauge set.
- D** Adjust dry nitrogen pressure to 150 psig (1034 kPa). Open the valve on the high side of the manifold gauge set in order to pressurize the line set and the indoor unit.
- E** After a few minutes, open one of the service valve ports and verify that the refrigerant added to the system earlier is measurable with a leak detector.
- F** After leak testing disconnect gauges from service ports.

Figure 13. Leak Test

Evacuating Line Set and Indoor Coil

1 CONNECT GAUGE SET

NOTE — Remove cores from service valves (if not already done).

- A Connect low side of manifold gauge set with 1/4 SAE in-line tee to *vapor* line service valve
- B Connect high side of manifold gauge set to *liquid* line service valve
- C Connect micron gauge available connector on the 1/4 SAE in-line tee.
- D Connect the vacuum pump (with vacuum gauge) to the center port of the manifold gauge set. The center port line will be used later for both the HFC-410A and nitrogen containers.

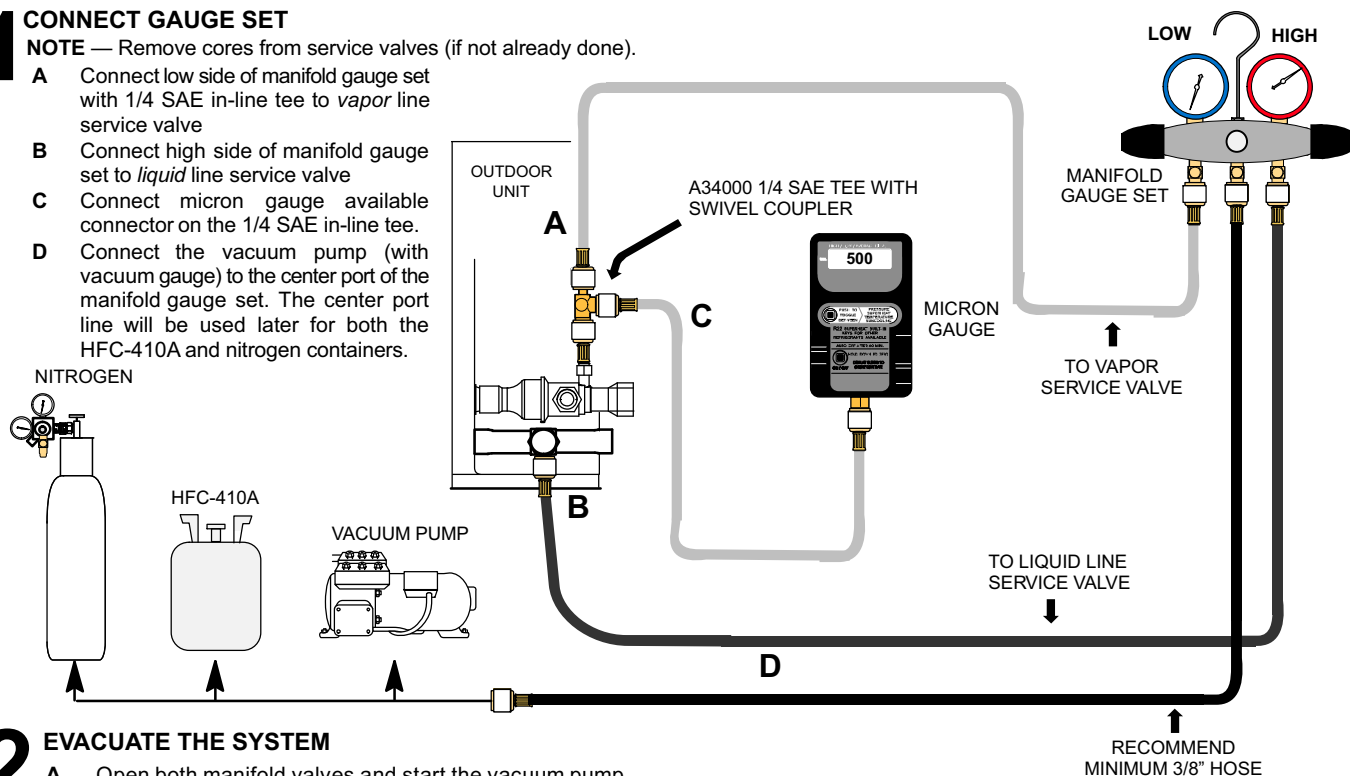

2 EVACUATE THE SYSTEM

- A Open both manifold valves and start the vacuum pump.
- B Evacuate the line set and indoor unit to an **absolute pressure** of 23,000 microns (29.01 inches of mercury).

NOTE — During the early stages of evacuation, it is desirable to close the manifold gauge valve at least once. A rapid rise in pressure indicates a relatively large leak. If this occurs, **repeat the leak testing procedure**.

NOTE — The term **absolute pressure** means the total actual pressure within a given volume or system, above the absolute zero of pressure. Absolute pressure in a vacuum is equal to atmospheric pressure minus vacuum pressure.
- C When the absolute pressure reaches 23,000 microns (29.01 inches of mercury), perform the following:
 - Close manifold gauge valves
 - Close valve on vacuum pump
 - Turn off vacuum pump
 - Disconnect manifold gauge center port hose from vacuum pump
 - Attach manifold center port hose to a dry nitrogen cylinder with pressure regulator set to 150 psig (1034 kPa) and purge the hose.
 - Open manifold gauge valves to break the vacuum in the line set and indoor unit.
 - Close manifold gauge valves.
- D Shut off the dry nitrogen cylinder and remove the manifold gauge hose from the cylinder. Open the manifold gauge valves to release the dry nitrogen from the line set and indoor unit.
- E Reconnect the manifold gauge to the vacuum pump, turn the pump on, and continue to evacuate the line set and indoor unit until the absolute pressure does not rise above 500 microns (29.9 inches of mercury) within a 20-minute period after shutting off the vacuum pump and closing the manifold gauge valves.
- F When the absolute pressure requirement above has been met, disconnect the manifold hose from the vacuum pump and connect it to an upright cylinder of HFC-410A refrigerant. Open the manifold gauge valve 1 to 2 psig in order to release the vacuum in the line set and indoor unit.
- G Perform the following:
 - Close manifold gauge valves.
 - Shut off HFC-410A cylinder.
 - Reinstall service valve cores by removing manifold hose from service valve. Quickly install cores with core tool while maintaining a positive system pressure.
 - Replace stem caps and secure finger tight, then tighten an additional one-sixth (1/6) of a turn as illustrated.

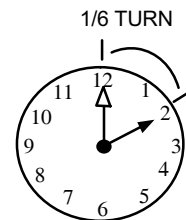

Figure 14. Evacuating System

⚠ WARNING

Danger of Equipment Damage. Avoid deep vacuum operation. Do not use compressors to evacuate a system. Extremely low vacuums can cause internal arcing and compressor failure. Damage caused by deep vacuum operation will void warranty.

⚠ CAUTION

Brazing alloys and flux contain materials which are hazardous to your health.

Avoid breathing vapors or fumes from brazing operations. Perform operations only in well ventilated areas.

Wear gloves and protective goggles or face shield to protect against burns.

Wash hands with soap and water after handling brazing alloys and flux.

Evacuating the system of non-condensables is critical for proper operation of the unit. Non-condensables are

defined as any gas that will not condense under temperatures and pressures present during operation of an air conditioning system. Non-condensables and water suction combine with refrigerant to produce substances that corrode copper piping and compressor parts.

⚠ IMPORTANT

Use a thermocouple or thermistor electronic vacuum gauge that is calibrated in microns. Use an instrument capable of accurately measuring down to 50 microns.

Electrical

In the U.S.A., wiring must conform with current local codes and the current National Electric Code (NEC). In Canada, wiring must conform with current local codes and the current Canadian Electrical Code (CEC).

Refer to the furnace or air handler installation instructions for additional wiring application diagrams and refer to unit nameplate for minimum circuit ampacity and maximum overcurrent protection size.

24VAC TRANSFORMER

Use the transformer provided with the furnace or air handler for low-voltage control power (24VAC - 40 VA minimum)

SIZE CIRCUIT AND INSTALL SERVICE DISCONNECT SWITCH

Refer to the unit nameplate for minimum circuit ampacity, and maximum fuse or circuit breaker (HACR per NEC). Install power wiring and properly sized disconnect switch.

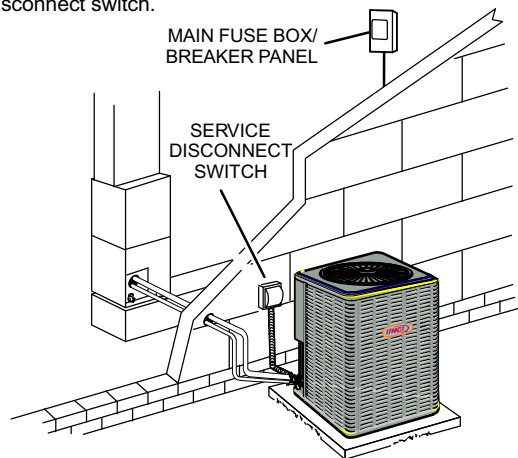

NOTE — Units are approved for use only with copper conductors. Ground unit at disconnect switch or to an earth ground.

INSTALL THERMOSTAT

Install room thermostat (ordered separately) on an inside wall approximately in the center of the conditioned area and 5 feet (1.5m) from the floor. It should not be installed on an outside wall or where it can be affected by sunlight or drafts.

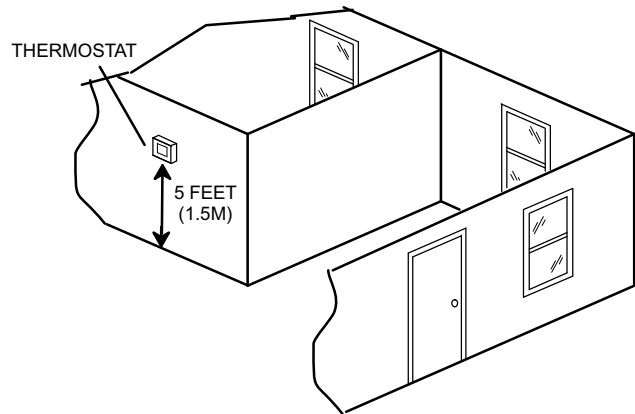

NOTE — 24VAC, Class II circuit connections are made in the control panel.

⚠ WARNING



Electric Shock Hazard. Can cause injury or death. Unit must be grounded in accordance with national and local codes.

Line voltage is present at all components when unit is not in operation on units with single-pole contactors. Disconnect all remote electric power supplies before opening access panel. Unit may have multiple power supplies.

ROUTING HIGH VOLTAGE/ GROUND AND CONTROL WIRING

HIGH VOLTAGE / GROUND WIRES

Any excess high voltage field wiring should be trimmed and secured away from any low voltage field wiring. To facilitate a conduit, a cutout is located in the bottom of the control panel. Connect conduit to the control panel using a proper conduit fitting.

LOW VOLTAGE CONTROL WIRING

NOTE — Wire tie provides low voltage control wire strain relief and to maintain separation of field installed low and high voltage circuits.

NOTE — For proper voltages, select thermostat wire (control wires) gauge per table above.

NOTE — Do not bundle any excess 24VAC control wires inside control panel.

Install low voltage wiring from outdoor to indoor unit and from thermostat to indoor unit as illustrated.

- A** Run 24VAC control wires through hole with grommet and secure with provided wire tie.
- B** Make 24VAC thermostat wire connections. Locate the two wires from the contactor and make connection using field provided wire nuts:
 - **Yellow to Y1**
 - **Black to C (common)**

WIRE RUN LENGTH	AWG#	INSULATION TYPE
LESS THAN 100' (30 METERS)	18	TEMPERATURE RATING
MORE THAN 100' (30 METERS)	16	35°C MINIMUM.

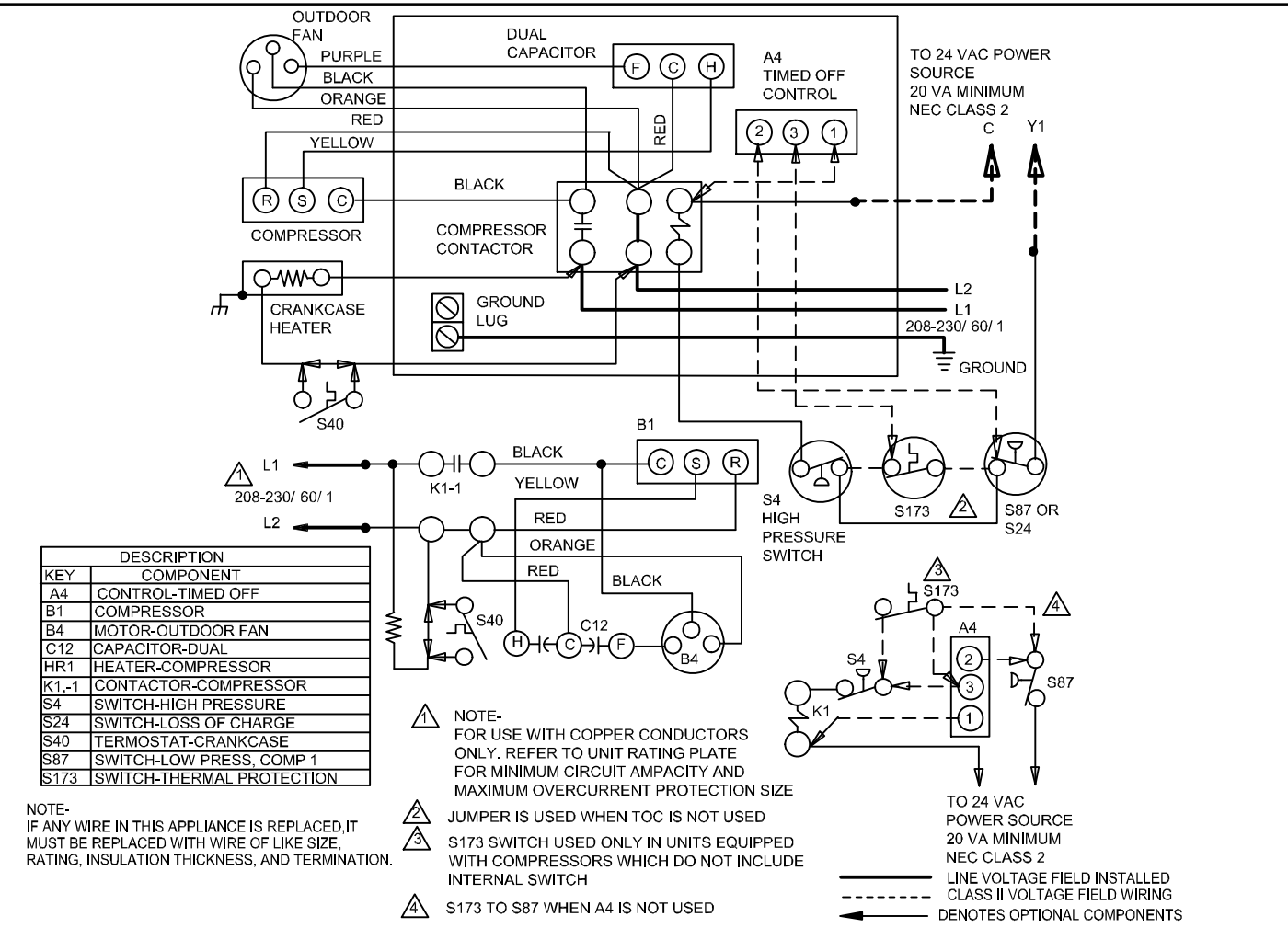
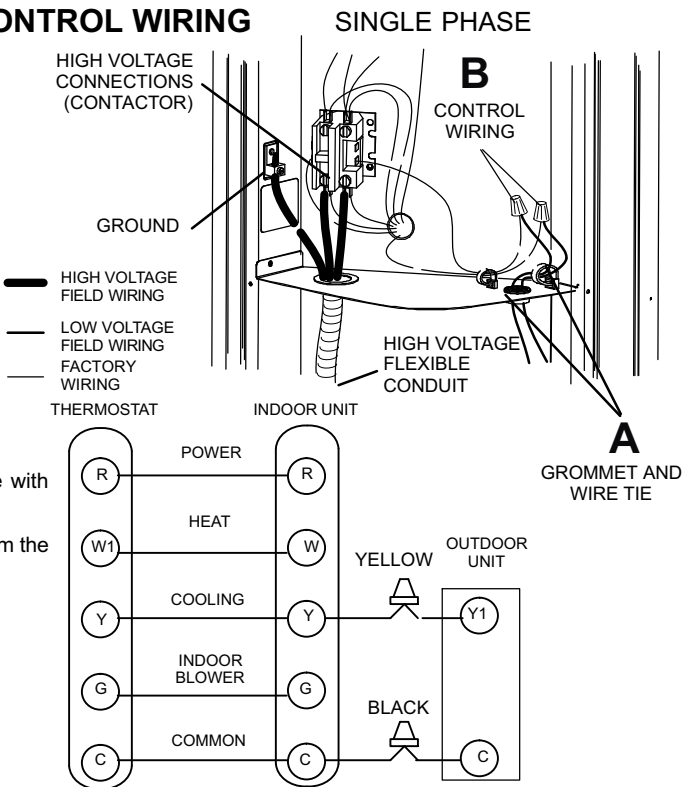

Figure 15. Typical Field Wiring Diagram

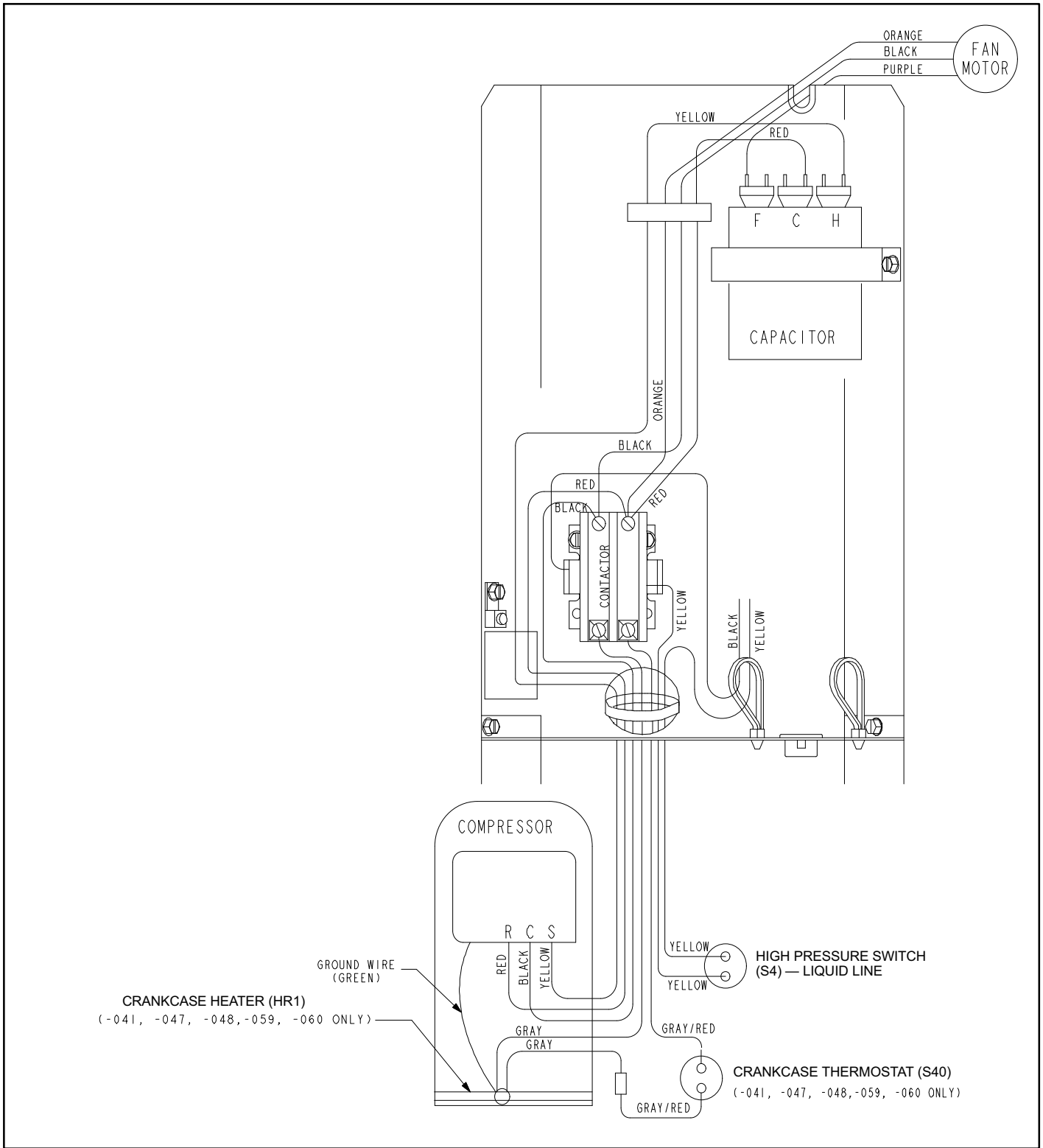

Figure 16. Typical Factory Wiring Diagram (Copeland Compressor)

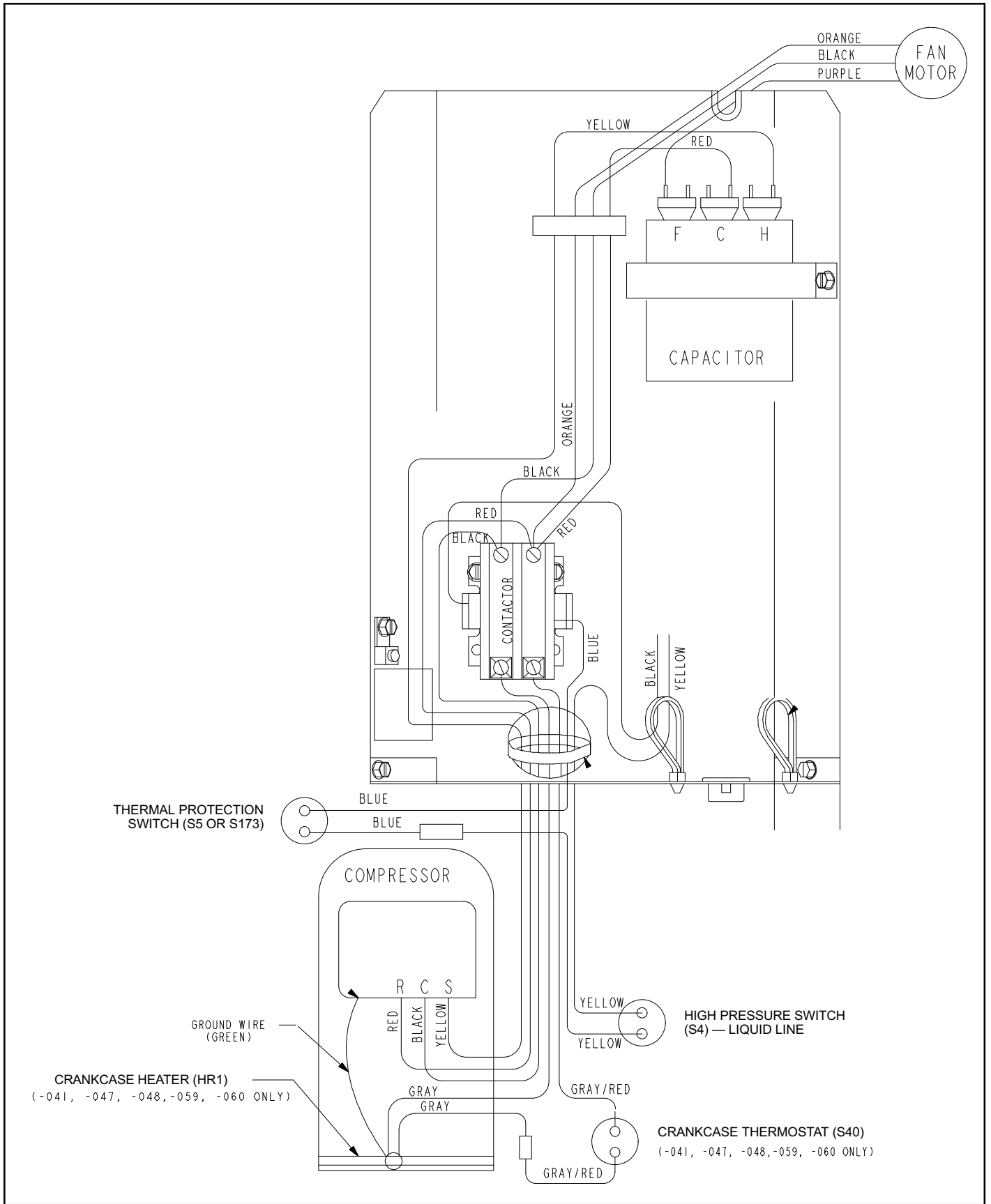

Figure 17. Typical Factory Wiring Diagram (Interlink Compressor)

Servicing Units Delivered Void of Charge

If the outdoor unit is void of refrigerant, clean the system using the procedure described below.

1. Leak check system using procedure outlined in this instruction.
2. Evacuate the system using procedure outlined in this instruction.
3. Use nitrogen to break the vacuum and install a new filter drier in the system.
4. Evacuate the system again using procedure outlined in this instruction.
5. Weigh in refrigerant using procedure outlined under *Start-Up and Charging Procedures*.
6. Monitor the system to determine the amount of moisture remaining in the oil. It may be necessary to replace the filter drier several times to achieve the required dryness level. **If system dryness is not verified, the compressor will fail in the future.**

Unit Start-Up

⚠ IMPORTANT

If unit is equipped with a crankcase heater, it should be energized 24 hours before unit start-up to prevent compressor damage as a result of slugging.

1. Rotate fan to check for binding.

2. Inspect all factory- and field-installed wiring for loose connections.
3. After evacuation is complete, open the liquid line and suction line service valve stems (*Operating Service Valves* on page 4) to release the refrigerant charge (contained in outdoor unit) into the system.
4. Replace the stem caps and tighten to the value listed in table 1.
5. Check voltage supply at the disconnect switch. The voltage must be within the range listed on the unit's nameplate. If not, do not start the equipment until you have consulted with the power company and the voltage condition has been corrected.
6. Connect manifold gauge set for testing and charging using figure 18 as a guideline.
7. Set the thermostat for a cooling demand. Turn on power to the indoor indoor unit and close the outdoor unit disconnect switch to start the unit.
8. Recheck voltage while the unit is running. Power must be within range shown on the unit nameplate.
9. Check system for sufficient refrigerate using the procedures outlined in under *System Refrigerant*.

System Refrigerant

This section outlines procedures for:

1. Connecting gauge set for testing and charging;
2. Checking and adjusting indoor airflow;
3. Adding or removing refrigerant.

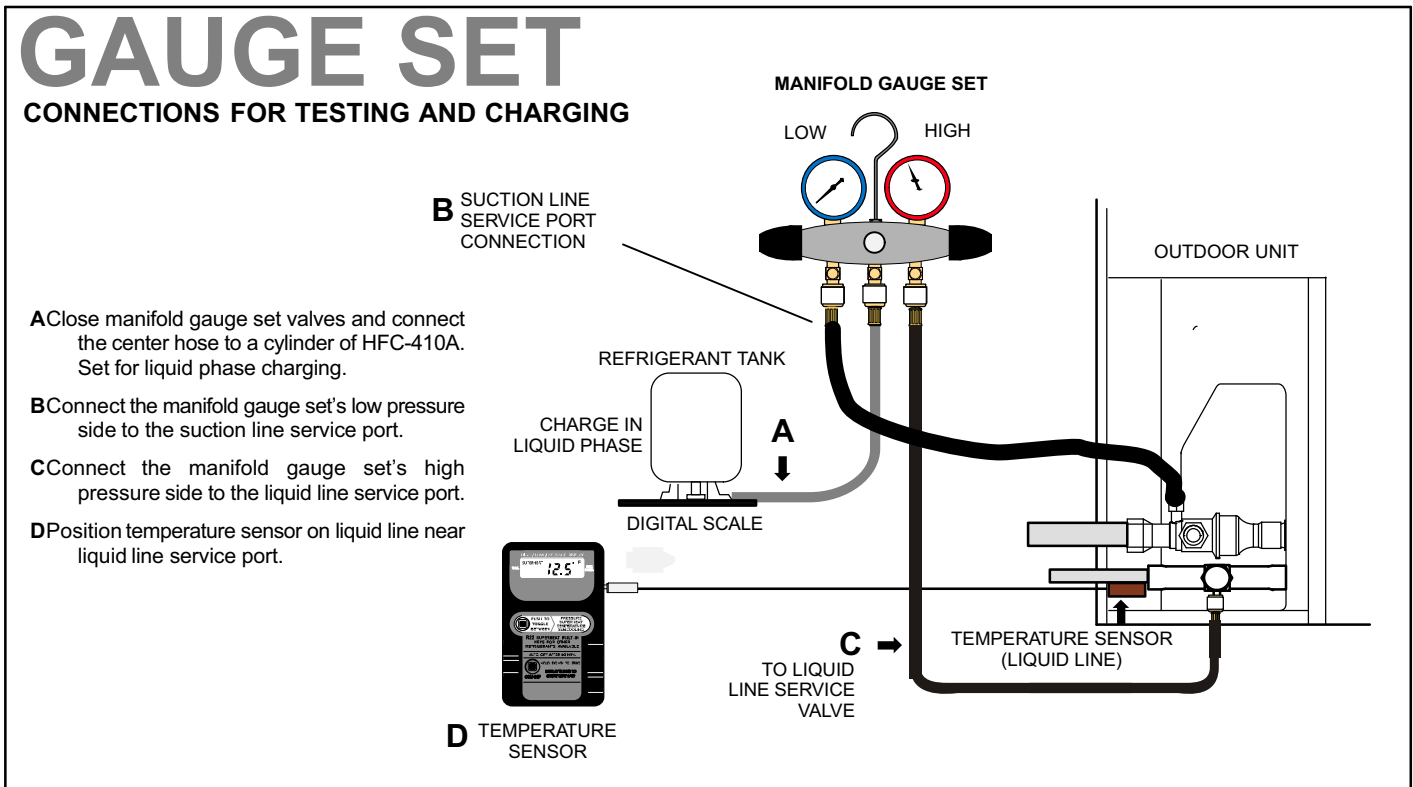

Figure 18. Manifold Gauge Set Setup and Connections

CHECKING AIR FLOW AT INDOOR COIL

Check airflow using the Delta-T (DT) process using the illustration in figure 19.

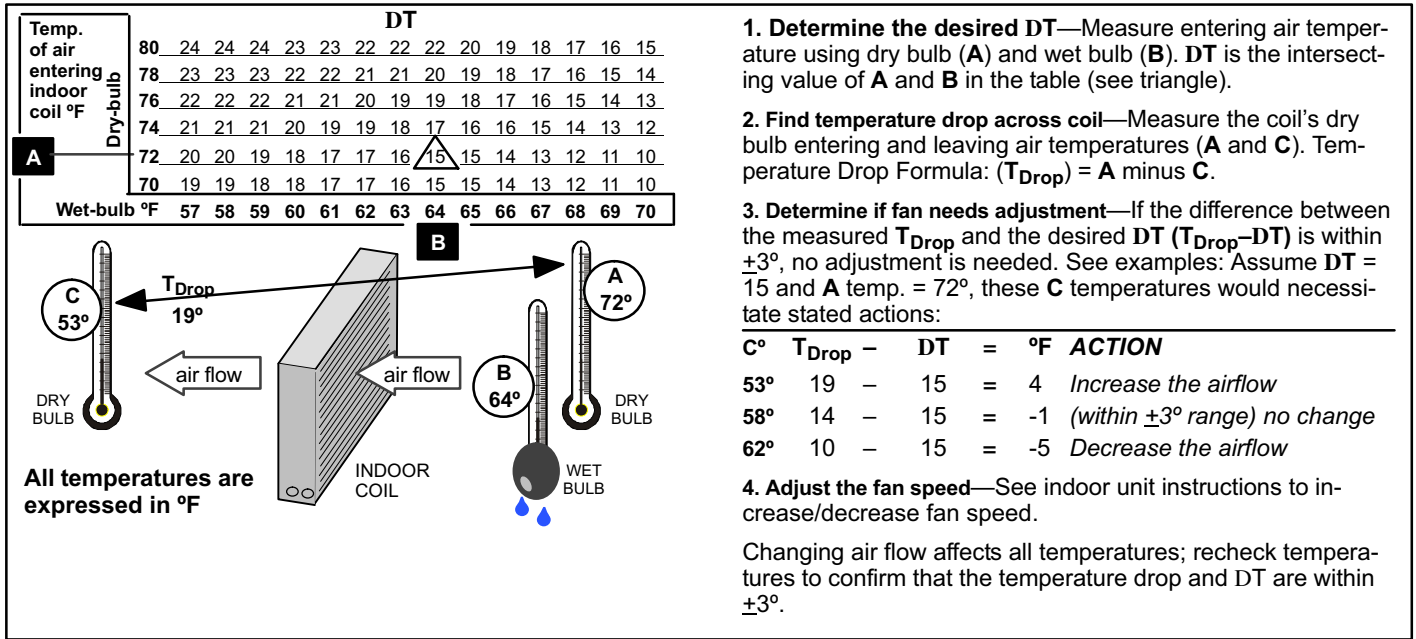

Figure 19. Checking Indoor Airflow over Evaporator Coil using Delta-T Chart

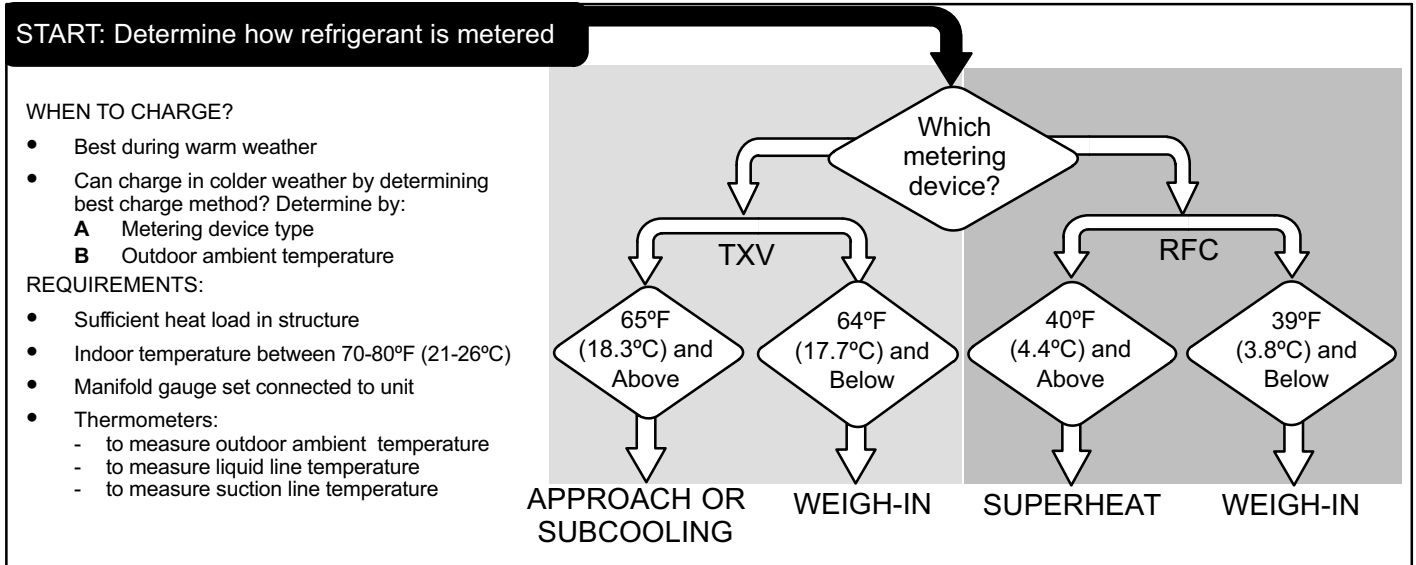
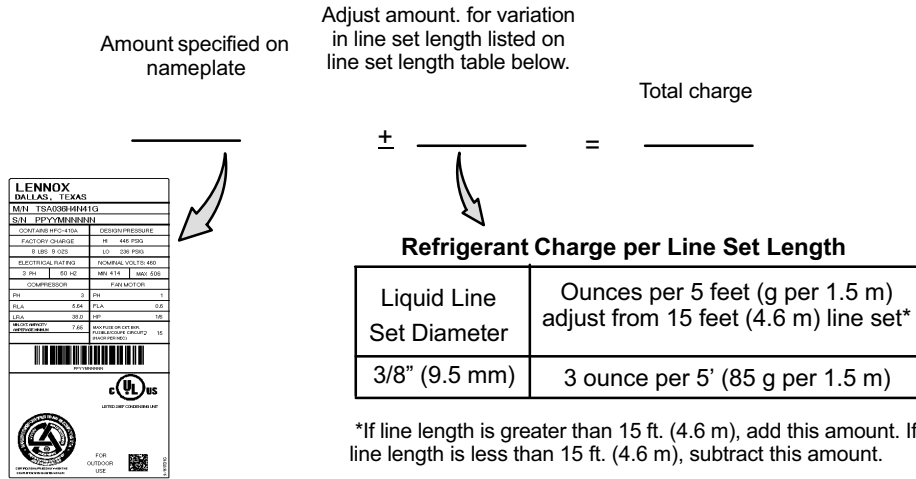

Figure 20. Determining Charge Method

WEIGH IN (RFC AND TXV)

CALCULATING SYSTEM CHARGE FOR OUTDOOR UNIT VOID OF CHARGE

If the system is void of refrigerant, first, locate and repair any leaks and then weigh in the refrigerant charge into the unit. To calculate the total refrigerant charge:



NOTE — Insulate liquid line when it is routed through areas where the surrounding ambient temperature could become higher than the temperature of the liquid line or when pressure drop is equal to or greater than 20 psig.

NOTE — The above nameplate is for illustration purposes only. Go to actual nameplate on outdoor unit for charge information.

Figure 21. Using HFC-410A Weigh In Method

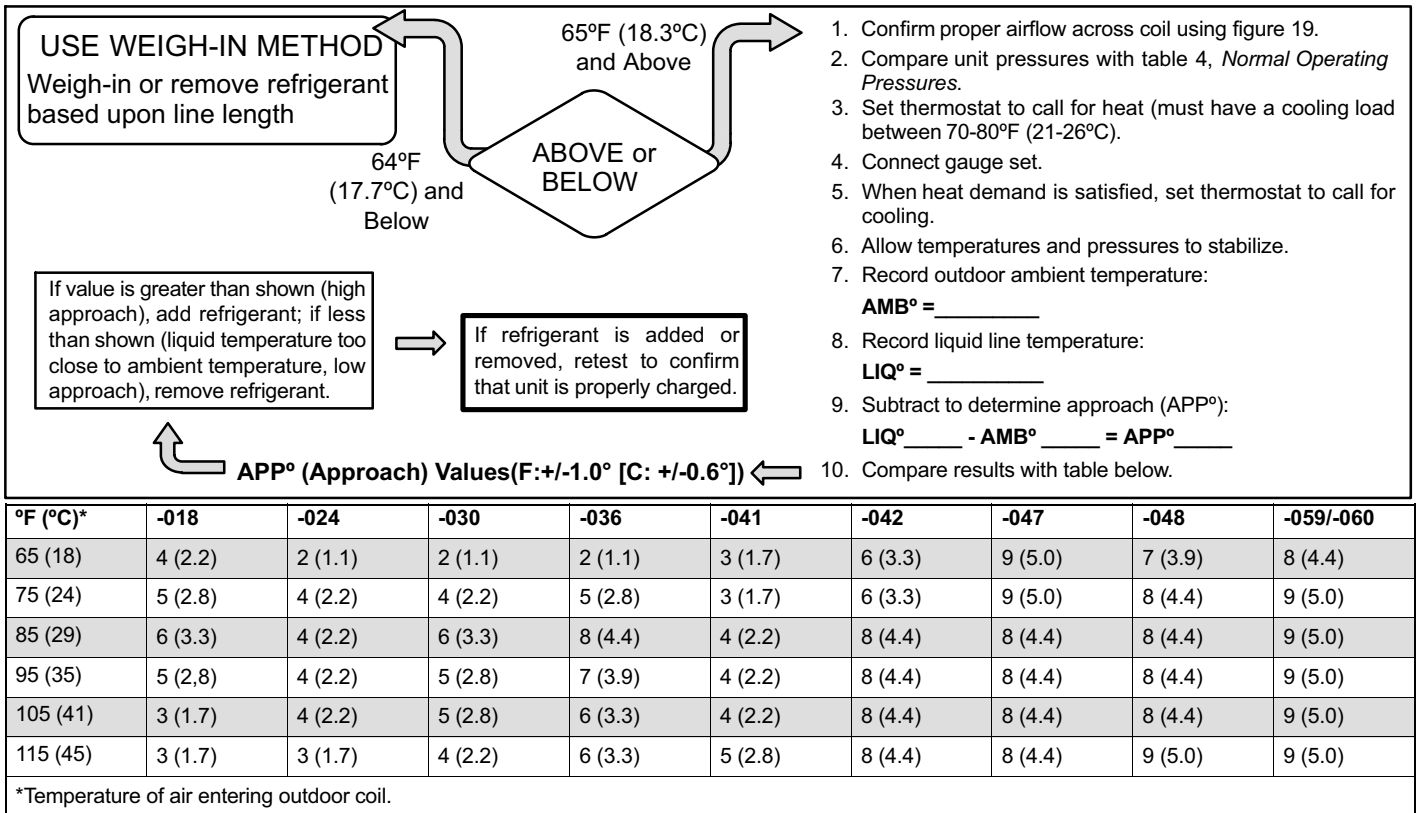
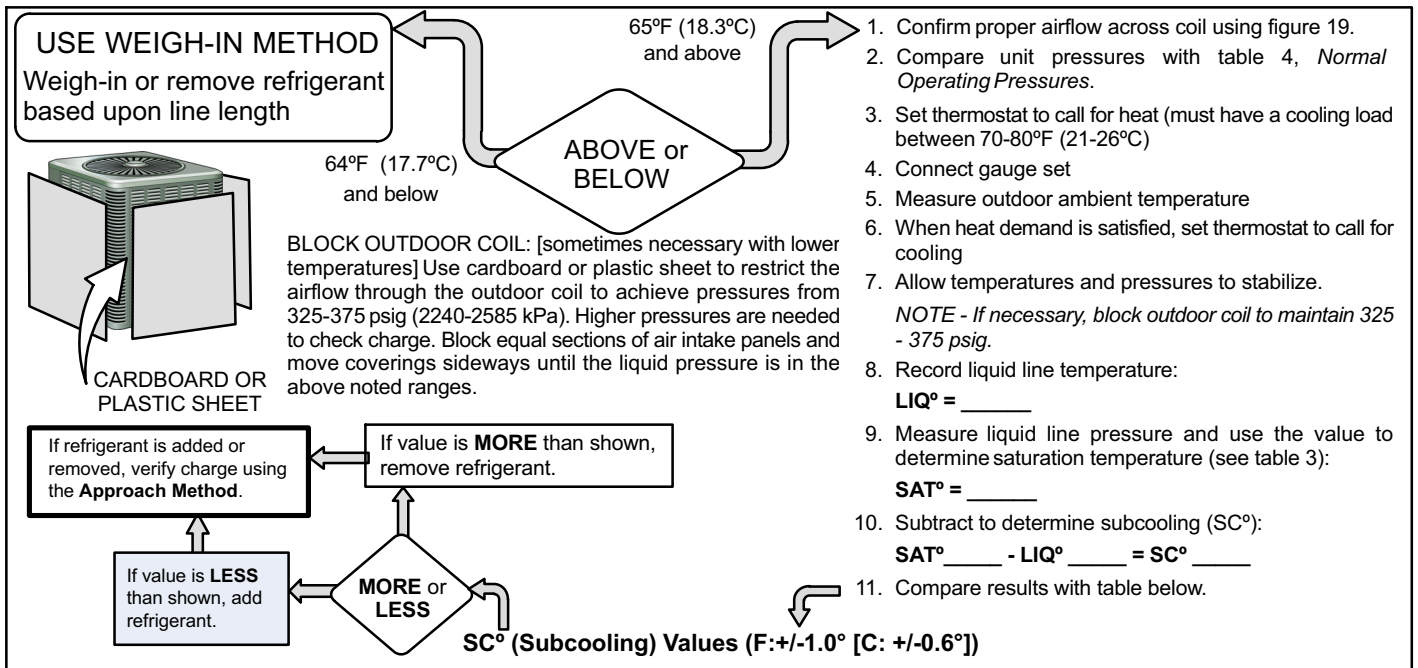

Figure 22. HFC-410A Approach TXV Charge



°F (°C)*	-018	-024	-030	-036	-041	-042	-047	-048	-059/-060
65 (18)	10 (5.6)	10 (5.6)	11 (6.1)	13 (7.2)	9 (5.0)	10 (5.6)	6 (3.3)	8 (4.4)	8 (4.4)
75 (24)	6 (3.3)	7 (3.9)	8 (4.4)	9 (5.0)	7 (3.9)	7 (3.9)	6 (3.3)	8 (4.4)	7 (3.9)
85 (29)	6 (3.3)	8 (4.4)	6 (3.3)	7 (3.9)	7 (3.9)	8 (4.4)	6 (3.3)	8 (4.4)	8 (4.4)
95 (35)	6 (3.3)	9 (5.0)	6 (3.3)	8 (4.4)	7 (3.9)	8 (4.4)	6 (3.3)	8 (4.4)	7 (3.9)
105 (41)	10 (5.6)	9 (5.0)	7 (3.9)	9 (5.0)	7 (3.9)	8 (4.4)	6 (3.3)	8 (4.4)	6 (3.3)
115 (45)	10 (5.6)	10 (5.6)	8 (4.4)	10 (5.6)	6 (3.3)	7 (3.9)	5 (2.8)	7 (3.9)	6 (3.3)

*Temperature of air entering outdoor coil.

Figure 23. HFC-410A Subcooling TXV Charge

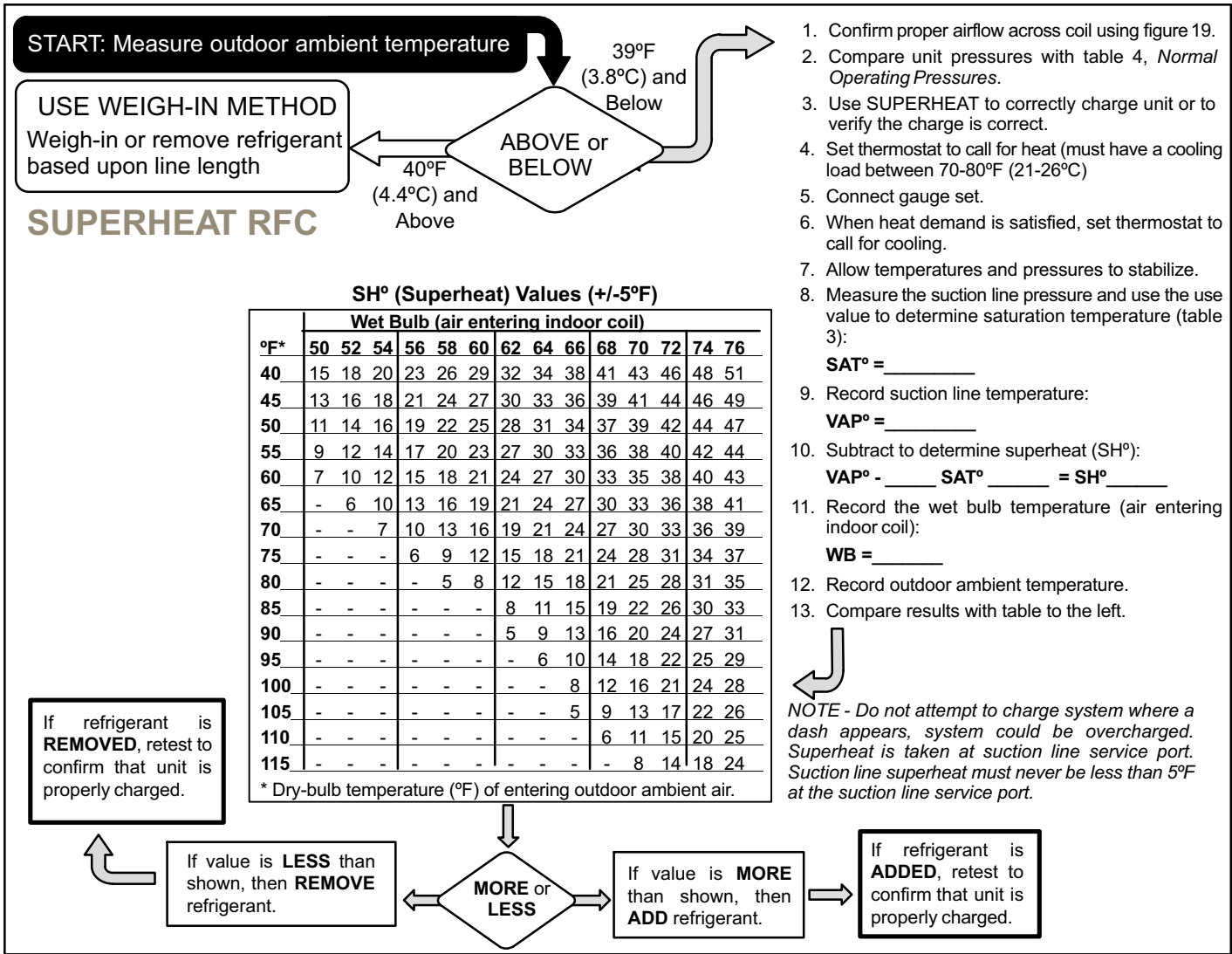

Figure 24. HFC-410A Superheat RFC Method

Table 3. HFC-410A Temperature — Pressure (Psig)

°F	°C	Psig	°F	°C	Psig
-40	-40.0	11.6	60	15.6	170
-35	-37.2	14.9	65	18.3	185
-30	-34.4	18.5	70	21.1	201
-25	-31.7	22.5	75	23.9	217
-20	-28.9	26.9	80	26.7	235
-15	-26.1	31.7	85	29.4	254
-10	-23.3	36.8	90	32.2	274
-5	-20.6	42.5	95	35.0	295
0	-17.8	48.6	100	37.8	317
5	-15.0	55.2	105	40.6	340
10	-12.2	62.3	110	43.3	365
15	-9.4	70.0	115	46.1	391
20	-6.7	78.3	120	48.9	418
25	-3.9	87.3	125	51.7	446
30	-1.1	96.8	130	54.4	476
35	1.7	107	135	57.2	507
40	4.4	118	140	60.0	539
45	7.2	130	145	62.8	573
50	10.0	142	150	65.6	608
55	12.8	155			

Table 4. HFC-410A Normal Operating Pressures (Liquid +10 and Suction +5 psig)

⚠ IMPORTANT

Use this table to perform maintenance checks; it is not a procedure for charging the system. Minor variations in these pressures may be due to differences in installations. Significant deviations could mean that the system is not properly charged or that a problem exists with some component in the system.

Model	-018	-024	-030	-036	-041	-042	-047	-048	-059/-060
**Temp. °F (°C)	Liquid / Suction	Liquid / Suction	Liquid / Suction	Liquid / Suction	Liquid / Suction	Liquid / Suction	Liquid / Suction	Liquid / Suction	Liquid / Suction
Expansion Valve (TXV)*									
65 (18)	230 / 138	225 / 135	226 / 129	238 / 132	233 / 142	236 / 138	233 / 139	238 / 136	239 / 133
70 (21)	244 / 139	242 / 137	241 / 131	254 / 135	239 / 142	253 / 140	252 / 140	256 / 138	258 / 135
75 (24)	265 / 140	260 / 138	259 / 134	273 / 138	256 / 143	273 / 141	272 / 141	277 / 139	278 / 136
80 (27)	286 / 140	282 / 140	281 / 138	293 / 140	278 / 144	296 / 142	294 / 142	299 / 140	300 / 137
85 (29)	307 / 142	304 / 141	301 / 140	316 / 142	299 / 145	318 / 143	315 / 142	320 / 139	323 / 138
90 (32)	330 / 143	326 / 142	324 / 141	340 / 143	321 / 145	341 / 144	338 / 144	343 / 140	346 / 139
95 (35)	351 / 144	351 / 142	348 / 142	366 / 144	343 / 146	366 / 146	361 / 144	369 / 141	370 / 140
100 (38)	380 / 144	376 / 144	372 / 143	392 / 145	366 / 147	392 / 147	387 / 144	395 / 142	396 / 142
105 (41)	407 / 145	403 / 145	399 / 144	420 / 147	389 / 148	417 / 148	413 / 145	422 / 144	415 / 143
110 (43)	436 / 146	433 / 145	428 / 145	449 / 148	421 / 149	445 / 149	442 / 148	450 / 146	449 / 145
115 (45)	466 / 147	463 / 147	456 / 146	480 / 149	452 / 151	475 / 151	465 / 148	481 / 148	476 / 147
Fixed Orifice (RFC)*									
65 (18)	232 / 124	228 / 125	229 / 128	241 / 131	228 / 131	248 / 135	232 / 125	240 / 126	244 / 125
70 (21)	248 / 127	244 / 127	243 / 129	258 / 134	245 / 135	266 / 138	249 / 129	260 / 129	263 / 128
75 (24)	267 / 131	261 / 131	261 / 132	277 / 136	263 / 138	285 / 141	268 / 133	281 / 133	281 / 131
80 (27)	286 / 135	284 / 134	284 / 135	298 / 139	284 / 141	305 / 143	286 / 136	301 / 135	303 / 134
85 (29)	307 / 138	303 / 137	305 / 138	321 / 141	306 / 144	327 / 145	312 / 140	324 / 138	324 / 136
90 (32)	328 / 141	325 / 140	327 / 140	342 / 143	327 / 146	349 / 147	332 / 142	346 / 140	347 / 139
95 (35)	351 / 143	347 / 142	349 / 142	366 / 145	348 / 148	372 / 149	357 / 144	371 / 142	370 / 141
100 (38)	375 / 146	370 / 144	372 / 144	392 / 147	372 / 149	396 / 150	379 / 146	395 / 144	394 / 143
105 (41)	400 / 148	394 / 146	396 / 146	416 / 149	395 / 151	421 / 152	406 / 149	420 / 146	418 / 145
110 (43)	426 / 150	420 / 148	422 / 148	446 / 151	424 / 153	447 / 153	430 / 150	447 / 148	444 / 146
115 (46)	457 / 153	447 / 150	449 / 150	480 / 152	453 / 155	476 / 154	460 / 152	473 / 150	471 / 147

*Values shown are typical pressures; indoor unit match up, indoor air quality equipment, and indoor load will cause the pressures to vary.

**Temperature of the air entering the outside coil.

System Operation

UNIT COMPONENTS

⚠ IMPORTANT

Some scroll compressor have internal vacuum protector that will unload scrolls when suction pressure goes below 20 psig. A hissing sound will be heard when the compressor is running unloaded. Protector will reset when low pressure in system is raised above 40 psig. **DO NOT REPLACE COMPRESSOR.**

High Pressure Switch (S4)

14ACX units are equipped with a high-pressure switch that is located in the liquid line of the compressor as illustrated in figure on page 2 and figure 25 for the location of the manual reset button..

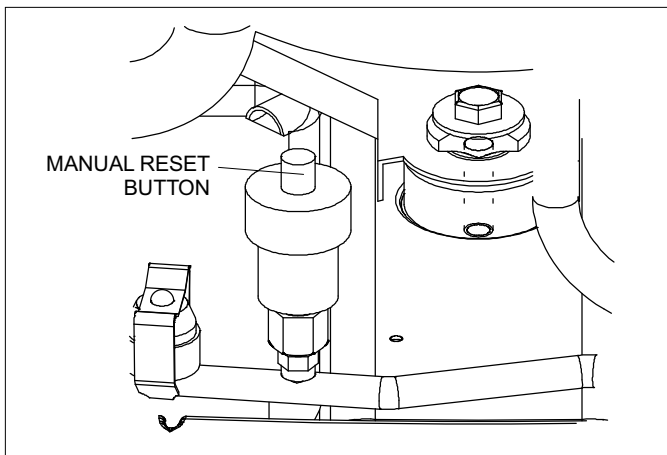

Figure 25. High Pressure Switch (S4) Manual Reset

The switch is a Single Pole, Single Throw (SPST), manual-reset switch which is normally closed and removes power from the compressor when discharge pressure rises above factory setting at 590 ± 10 psi. The manual-reset button can be identified by a red cap that is press to perform the reset function.

Thermal Protection Switch (S173) — Compressor Mounted

Some units are equipped with a compressor mounted normally closed temperature switch that prevents compressor damage due to overheating caused by internal friction. The switch is located on top of the compressor casing (see figure 1). This switch senses the compressor casing temperature and opens at 239-257°F (115°C-125°C) to shut off compressor operation. The auto-reset switch closes when the compressor casing

temperature falls to 151-187°F (66°C-86°C), and the compressor is re-energized. This single-pole, single-throw (SPST) bi-metallic switch is wired in series with the 24V Y input signal to control compressor operation.

Crankcase Heater (HR1) and Thermostat Switch (S40) (-041 through -060 models only)

These models are equipped with either a 40 or 70 watt belly-band type crankcase heater. HR1 prevents liquid from accumulating in the compressor. HR1 is controlled by a single-pole, single-throw thermostat (SPST) switch (S40) located on the liquid line (see figure 1 for location). When liquid line temperature drops below 50°F the thermostat closes energizing HR1. The thermostat will open, de-energizing HR1 once liquid line temperature reaches 70° F.

Maintenance

DEALER

Maintenance and service must be performed by a qualified installer or service agency. At the beginning of each cooling season, the system should be checked as follows:

Outdoor Unit

1. Outdoor unit fan motor is pre-lubricated and sealed. No further lubrication is needed.
2. Visually inspect all connecting lines, joints and coils for evidence of oil leaks.
3. Check all wiring for loose connections.
4. Check for correct voltage at unit (unit operating).
5. Check amp draw on outdoor fan motor.

Motor Nameplate: _____ **Actual:** _____.

6. Inspect drain holes in coil compartment base and clean if necessary.

NOTE - If insufficient cooling occurs, the unit should be gauged and refrigerant charge should be checked.

Outdoor Coil

Clean and inspect outdoor coil (may be flushed with a water hose). Ensure power is off before cleaning.

NOTE — It may be necessary to flush the outdoor coil more frequently if it is exposed to substances which are corrosive or which block airflow across the coil (e.g., pet urine, cottonwood seeds, fertilizers, fluids that may contain high levels of corrosive chemicals such as salts)

Sea Coast — Moist air in ocean locations can carry salt, which is corrosive to most metal. Units that are located near the ocean require frequent inspections and maintenance. These inspections will determine the necessary need to wash the unit including the outdoor coil. Consult your installing contractor for proper intervals/procedures for your geographic area or service contract.

Indoor Unit

1. Clean or change filters.
2. Lennox blower motors are prelubricated and permanently sealed. No more lubrication is needed.
3. Adjust blower speed for cooling. Measure the pressure drop over the coil to determine the correct blower CFM. Refer to the unit information service manual for pressure drop tables and procedure.
4. *Belt Drive Blowers* - Check belt for wear and proper tension.
5. Check all wiring for loose connections.
6. Check for correct voltage at unit. (blower operating)
7. Check amp draw on blower motor.

Motor Nameplate: _____ **Actual:** _____.

Indoor Coil

1. Clean coil if necessary.
2. Check connecting lines, joints and coil for evidence of oil leaks.
3. Check condensate line and clean if necessary.

HOMEOWNER

Cleaning of the outdoor unit's coil should be performed by a trained service technician. Contact your dealer and set up a schedule (preferably twice a year, but at least once a year) to inspect and service your outdoor unit. The following maintenance may be performed by the homeowner.

IMPORTANT

Sprinklers and soaker hoses should not be installed where they could cause prolonged exposure to the outdoor unit by treated water. Prolonged exposure of the unit to treated water (i.e., sprinkler systems, soakers, waste water, etc.) will corrode the surface of steel and aluminum parts and diminish performance and longevity of the unit.

Outdoor Coil

The outdoor unit must be properly maintained to ensure its proper operation.

- Please contact your dealer to schedule proper inspection and maintenance for your equipment.
- Make sure no obstructions restrict airflow to the outdoor unit.
- Grass clippings, leaves, or shrubs crowding the unit can cause the unit to work harder and use more energy.

- Keep shrubbery trimmed away from the unit and periodically check for debris which collects around the unit.

Routine Maintenance

In order to ensure peak performance, your system must be properly maintained. Clogged filters and blocked airflow prevent your unit from operating at its most efficient level.

1. **Air Filter** — Ask your Lennox dealer to show you where your indoor unit's filter is located. It will be either at the indoor unit (installed internal or external to the cabinet) or behind a return air grille in the wall or ceiling. Check the filter monthly and clean or replace it as needed.

2. **Disposable Filter** — Disposable filters should be replaced with a filter of the same type and size.

NOTE — If you are unsure about the filter required for your system, call your Lennox dealer for assistance.

3. **Reusable Filter** — Many indoor units are equipped with reusable foam filters. Clean foam filters with a mild soap and water solution; rinse thoroughly; allow filter to dry completely before returning it to the unit or grille.

NOTE — The filter and all access panels must be in place any time the unit is in operation.

4. **Indoor Unit** — The indoor unit's evaporator coil is equipped with a drain pan to collect condensate formed as your system removes humidity from the inside air. Have your dealer show you the location of the drain line and how to check for obstructions. (This would also apply to an auxiliary drain, if installed.)

Thermostat Operation

See the thermostat homeowner manual for instructions on how to operate your thermostat.

Preservice Check

If your system fails to operate, check the following before calling for service:

- Verify room thermostat settings are correct.
- Verify that all electrical disconnect switches are ON.
- Check for any blown fuses or tripped circuit breakers.
- Verify unit access panels are in place.
- Verify air filter is clean.
- If service is needed, locate and write down the unit model number and have it handy before calling.

Accessories

For update-to-date information, see any of the following publications:

- Lennox 14ACX Engineering Handbook
- Lennox Product Catalog
- Lennox Price Book

Start-Up and Performance Checklist

Job Name _____ Job no. _____ Date _____

Job Location _____ City _____ State _____

Installer _____ City _____ State _____

Unit Model No. _____ Serial No. _____ Service Technician _____

Nameplate Voltage _____

Rated Load Ampacity _____ Compressor _____ Outdoor Fan _____

Maximum Fuse or Circuit Breaker _____

Electrical Connections Tight? Indoor Filter clean? Supply Voltage (Unit Off) _____

Indoor Blower RPM _____ S.P. Drop Over Indoor (Dry) _____ Outdoor Coil Entering Air Temp. _____

Discharge Pressure _____ Suction Pressure _____ Refrigerant Charge Checked?

Refrigerant Lines: - Leak Checked? Properly Insulated? Outdoor Fan Checked?

Service Valves: --- Fully Opened? Caps Tight? **Thermostat**

Voltage With Compressor Operating _____ Calibrated? Properly Set? Level?