



©2012 Lennox Industries Inc.
Dallas, Texas, USA



**THIS MANUAL MUST BE LEFT WITH THE
HOMEOWNER FOR FUTURE REFERENCE**

⚠ WARNING

Improper installation, adjustment, alteration, service or maintenance can cause personal injury, loss of life, or damage to property.

Installation and service must be performed by a licensed professional installer (or equivalent) or a service agency.

⚠ IMPORTANT

The Clean Air Act of 1990 bans the intentional venting of refrigerant (CFCs, HCFCs and HFCs) as of July 1, 1992. Approved methods of recovery, recycling or reclaiming must be followed. Fines and/or incarceration may be levied for noncompliance.

⚠ WARNING

The State of California has determined that this product may contain or produce a chemical or chemicals, in very low doses, which may cause serious illness or death. It may also cause cancer, birth defects, or reproductive harm.

INSTALLATION INSTRUCTIONS

Merit® CBX25UH Series Units

TP Technical
Publications
Litho U.S.A.

AIR HANDLERS
506757-01 (0659371-80)
10/2012

Table of Contents

Shipping and Packing List	1
CBX25UH Series Units	1
Requirements	3
Installation Clearances	3
Installation	4
Condensate Drain	6
Duct System and Filters	7
Connecting Refrigerant Lines	8
Sealing the Unit	8
Electrical Connections	9
Airflow - Cooling Blower Speed	10
Check-Out Procedures	12
Operation	12
Maintenance	13
Cabinet Insulation	13

Shipping and Packing List

Package 1 of 1 contains the following:

- 1 - Assembled air handler unit for upflow or horizontal air discharge application (includes upflow and horizontal drain pans and **pre-installed air filter**).

Check equipment for shipping damage. If found, immediately report damage to the last carrier. Check the unit rating plate to confirm that delivered unit matches order.

General

The CBX25UH air handler is designed for indoor installation only. As shipped, the unit is ready for installation in either upflow, horizontal left-hand and right-hand air discharge applications. Electric heat, down flow air discharge application kits, air filters and other various accessories are available and listed in the *CBX25UH Product Specification bulletin* for ordering.

All units come with a factory installed check/expansion valve.



CBX25UH Unit Dimensions - inches (mm)

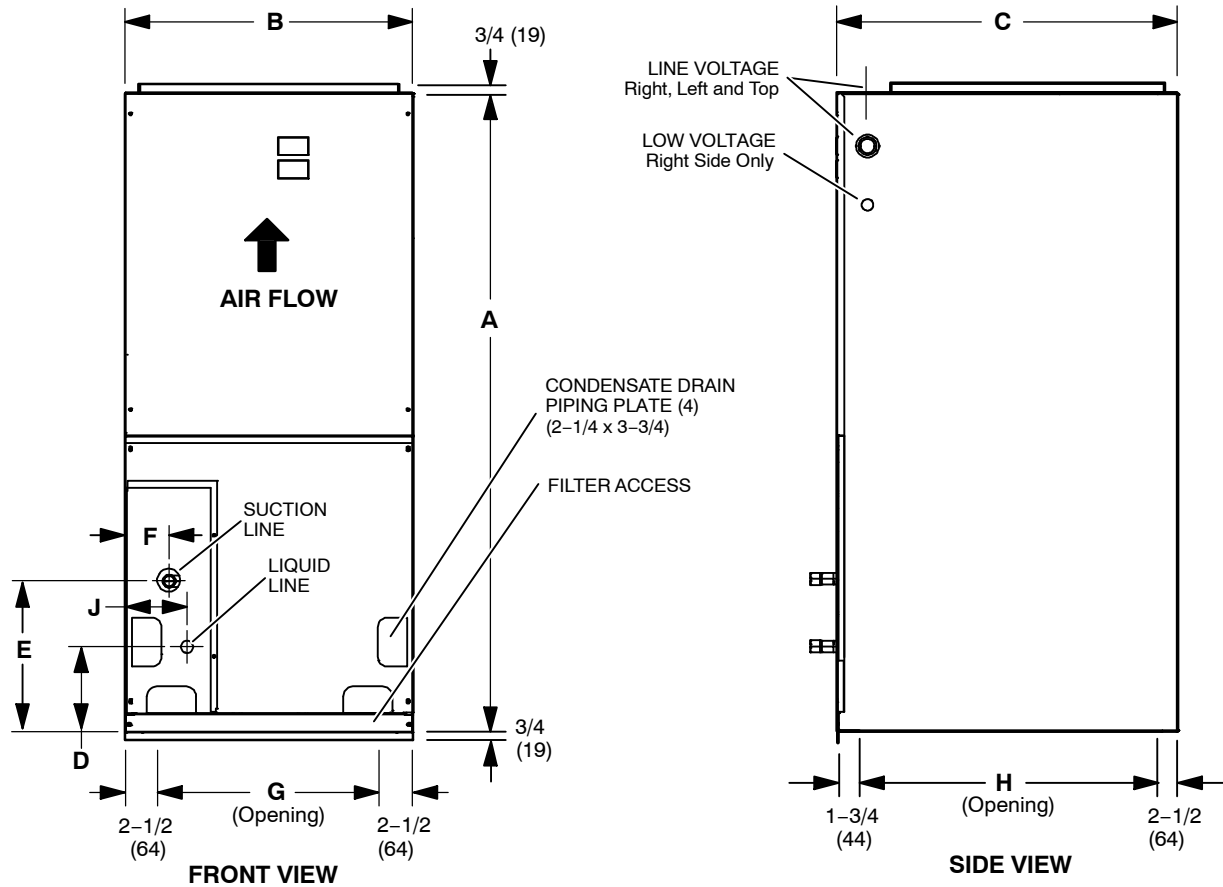

Dimension	-018		-024		-030		-036		-042		-048 / -060		
	inches	mm	inches	mm	inches	mm	inches	mm	inches	mm	inches	mm	
A	38	965	40-1/2	1029	43	1092	48	1219	48	1219	52-1/2	1334	
B	15	381	18-1/2	470	18-1/2	470	21-7/8	556	21-7/8	556	21-7/8	556	
C	22	559	22	559	22	559	22	559	26	660	26	660	
D	6	152	6	152	6	152	12-1/4	311	6-1/4	159	6-3/8	162	
E	11	279	14	357	16	406	18-7/8	479	17-7/8	454	15-1/4	387	
F	3-5/8	92	5-1/2	140	5-1/2	140	5-3/4	146	3-1/4	83	3-1/4	83	
G	10	254	13-1/2	343	13-1/2	343	16-7/8	429	16-7/8	429	16-7/8	429	
H	17-3/4	451	17-3/4	451	17-3/4	451	17-3/4	451	21-3/4	552	21-3/4	552	
J	3-5/8	92	5-1/2	140	5-1/2	140	5-3/4	146	4-5/8	117	6-3/8	162	
Supply Air Opening	Depth	17	432	17	432	17	432	17	432	21	533	21	533
	Width	13	330	16-1/2	419	16-1/2	419	19-7/8	505	19-7/8	505	19-7/8	505
Return Air Opening	Depth	20-3/4	527	20-3/4	527	20-3/4	527	20-3/4	527	24-3/4	629	24-3/4	629
	Width	12-1/2	318	16	406	16	406	19-3/8	492	19-3/8	492	19-3/8	492

Requirements

WARNING

Excessive Weight Hazard - Use two or more people when moving and installing the unit. Failure to do so can result in back or other type of injury.

IMPORTANT

The CBX25UH units are designed to match, and must be used with, outdoor units as rated. The indoor sections are manufactured with a check/expansion valve (TXV) to provide optimum refrigerant control and system performance with a variety of different capacities of outdoor units.

CAUTION

Physical contact with metal edges and corners while applying excessive force or rapid motion can result in personal injury. Be aware of, and use caution when working near these areas during installation or while servicing this equipment.

These instructions are intended as a general guide and do not supersede local or national codes in any way. Consult authorities having jurisdiction before installation.

Compliance with all local, state, or national codes pertaining to this type of equipment should be determined prior to installation. Read this instruction manual, as well as the instructions supplied in separate equipment, before starting the installation.

In addition to conforming to manufacturer's installation instructions and local municipal building codes, installation of Lennox air handler units (with or without optional electric heat), MUST conform with National Fire Protection Association (NFPA) standards: "Standard for Installation of Air Conditioning and Ventilation Systems" (NFPA No. 90A) and "Standard for Installation of Residence Type Warm Air Heating and Air Conditioning Systems" (NFPA No. 90B).

All models are designed for indoor installation only. The installation of the air handler, field wiring, duct system, etc. must conform to the requirements of the National Electrical Code, ANSI/NFPA No. 70 (latest edition) in the United States, and any state laws, and local ordinances (including plumbing or wastewater codes). Local authorities having jurisdiction should be consulted before installation is made. Such applicable regulations or requirements take precedence over the general instructions in this manual. Install the conditioned air plenum, ducts and air filters (provided) in accordance with NFPA 90B Standard for the Installation of Warm Air Heating and Air-Conditioning Systems (latest edition).

The air handler is shipped from the factory completely assembled. The unit is provided with flanges for the connection of the duct system.

Do not remove the cabinet knockouts until it has been determined which knockouts will need to be removed for the installation.

Select the final air discharge position which best suits the site conditions. Consider required clearances, space, routing requirements for refrigerant line, condensate disposal, filters, duct system, wiring, and accessibility for service. Refer to the air handler rating plate on the air handler for specific information.

WARNING



Danger of explosion. Keep flammable materials and vapors, such as gasoline, away from air handler. Place air handler so that heating elements are at least 18 inches (46 cm) above the floor for a garage installation. Failure to follow these instructions can result in death, explosion, or fire.

NOTES —

During cooling operation, excessive sweating may occur if the air handler is installed in a warm and humid space.

If installed in an unconditioned space, sealant should be applied around the electrical wires, refrigerant tubing, and condensate lines where they enter the cabinet.

Electrical wires should be sealed on the inside where they exit the conduit opening. Sealant is required to prevent air leakage into, and condensate from forming inside of, the air handler, the control box, and on the electrical controls.

This unit is approved for installation clearance to combustible material as stated on the unit rating plate. Accessibility and service clearances must take precedence over combustible material clearances.

The air handler must be installed so that free access is allowed to the coil/filter compartment and blower/control compartment.

Installation Clearances

NON-DUCTED RETURN CLOSET INSTALLATION

The air handler can be installed in a closet with a false bottom to form a return air plenum. It may also be installed with a return air plenum under the air handler.

Louvers or return air grilles are field-supplied. Local codes may limit application of systems without a ducted return to single story buildings.

When a CBX25UH unit is installed in a closet with a louvered return opening, the minimum open area for the louvers will be:

- 320 square inches for -018 and -024 models;
- 360 square inches for -030 and -036 models;
- 450 square inches for -042 thru -060 models.

If the free area is not known, assume a 25% free area for wood or a 75% free area for metal louvers or grilles. Using the louver dimensions and the 25% or 75% assumption, determine if the open area meets the minimum open area listed above.

If a return air plenum is used, the return air grille should be immediately in front of the opening in the plenum to allow for the free flow of return air. When not installed in front of the opening, there must be adequate clearance around the air handler to allow for the free flow of return air.

Installation

Each unit consists of a blower assembly, refrigerant coil, and controls, in an insulated galvanized steel factory finished enclosure. Knockouts are provided for electrical wiring entrance.

For ease in installation, it is best to make any necessary coil configuration changes before setting air handler in place.

REFRIGERANT METERING DEVICE

CB25UH units are equipped with a factory-installed check expansion valve.

UPFLOW APPLICATION

1. The air handler must be supported on the bottom only and set on solid floor or field-supplied support frame. Securely attach the air handler to the floor or support frame.
2. If installing a unit in an upflow application, remove the horizontal drain pan. **IMPORTANT - The horizontal drain pan is not required in upflow air discharge installations; its removal provides the best efficiency and air flow.**
3. Place the unit in the desired location and slope unit as previously mentioned. Connect return and supply air plenums as required using sheet metal screws.
4. Install units that have no return air plenum on a stand that is at least 14" from the floor. This will allow proper air return.

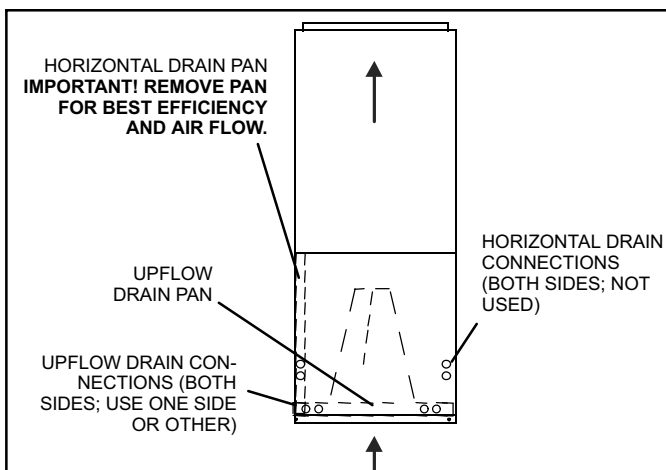

Figure 1. Upflow Configuration

HORIZONTAL APPLICATIONS

! IMPORTANT

When removing the coil, there is possible danger of equipment damage and personal injury. Be careful when removing the coil assembly from a unit installed in right- or left-hand applications. The coil may tip into the drain pan once it is clear of the cabinet. Support the coil when removing it.

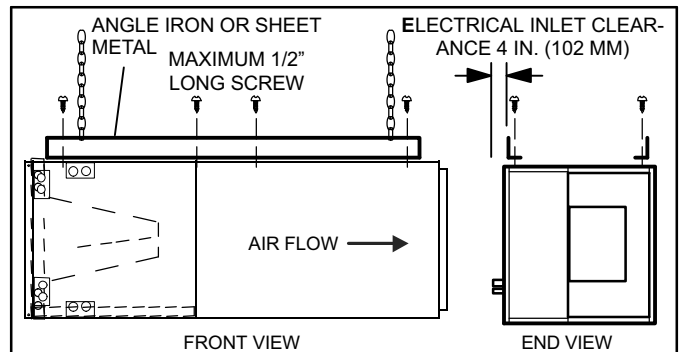

Figure 2. Suspending Horizontal Unit

NOTE — When the unit is installed in horizontal applications, a secondary drain pan is recommended. Refer to local codes.

NOTE — This unit may be installed in left-hand or right-hand air discharge horizontal applications. Adequate support must be provided to ensure cabinet integrity. Ensure that there is adequate room to remove service and access panels if installing in the horizontal position.

LEFT-HAND DISCHARGE

1. Determine knockouts required for drain line connections.
2. With access door removed, knock out drain line opening for installing drain lines.
3. Set unit so that it is sloped toward the drain pan end of the unit (see figure 10).
4. The horizontal configuration is shown in figure 3.

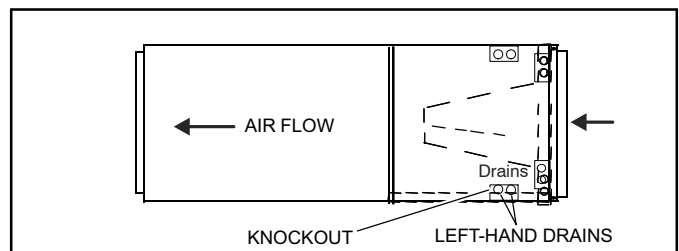

Figure 3. Left-Hand Discharge Configuration

5. If the unit is suspended, the entire length of the cabinet must be supported. If you use a chain or strap, use a piece of angle iron or sheet metal attached to the unit (either above or below) to support the length of the cabinet. Use securing screws no longer than 1/2 inch to avoid damaging the coil or filter. See figure 2. Use sheet metal screws to connect the return and supply air plenums as required.

RIGHT-HAND AIR DISCHARGE

For horizontal right-hand air discharge, the following field modifications are required.

1. Remove and set aside blower and coil access covers.
2. Remove bracket(s) securing pan(s) to unit as illustrated in figures 4 and 5.

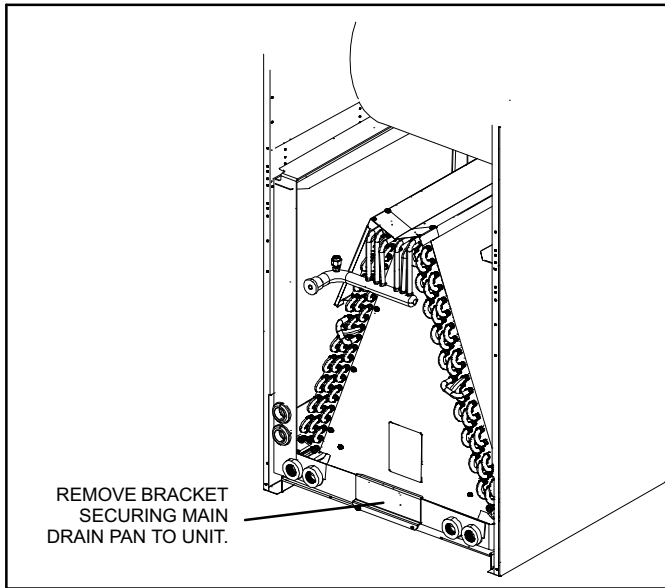

Figure 4. Remove Main Drain Pan Mounting Bracket (-018 through -036)

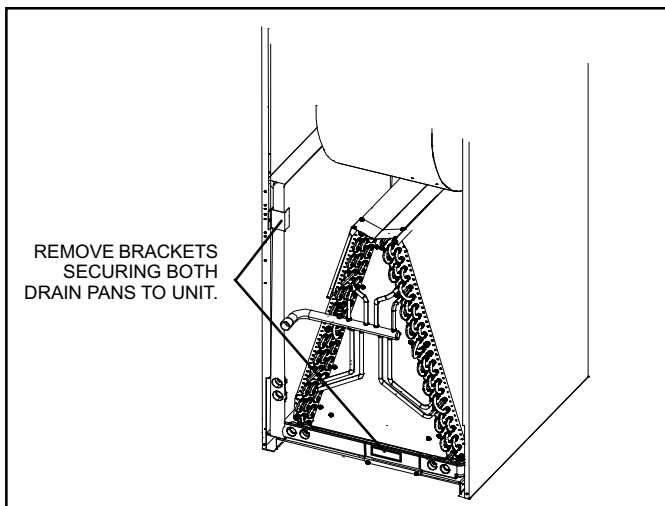

Figure 5. Remove Horizontal and Main Drain Pan Mounting Brackets (-042 through -060)

3. Remove coil assembly, bottom drain pan and horizontal drain pan as one assembly from the air handler.
4. Move the horizontal drain pan to the opposite side of the coil. Be sure drain holes toward the back of the unit are plugged. Remove the plugs from the front drain pan ports.
5. Re-install modified coil/drain pan assembly in air handler in the same orientation as before (figures 6 and 7).

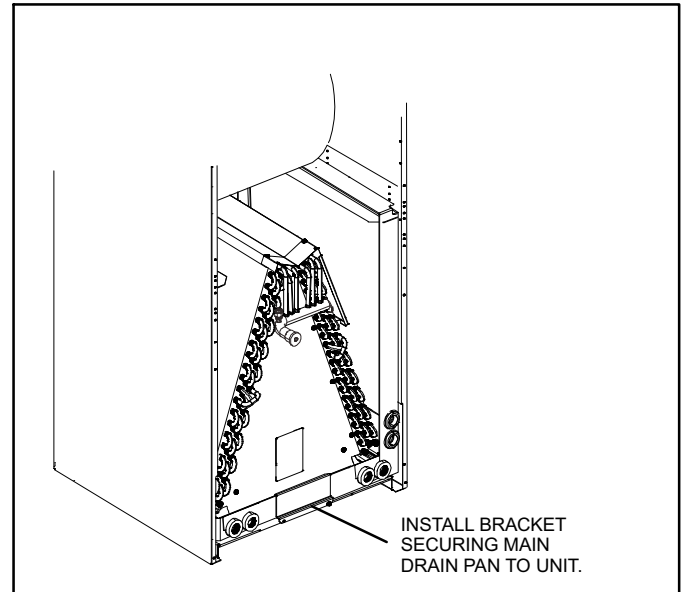

Figure 6. Install Main Drain Pan Mounting Bracket (-018 through -036)

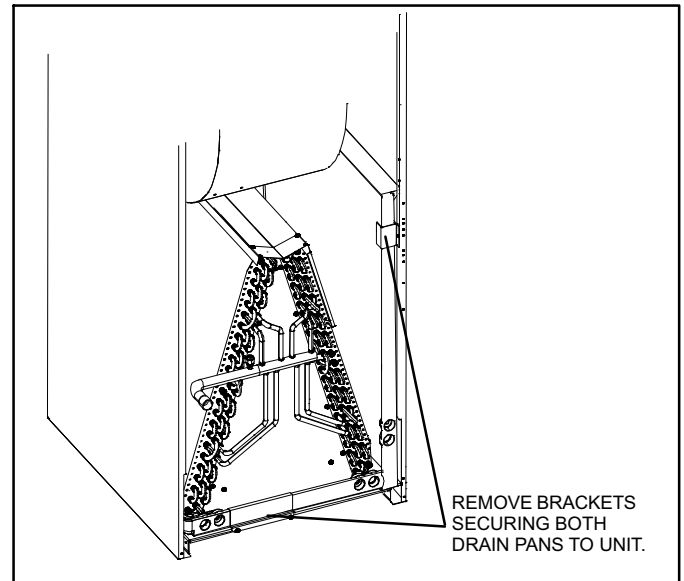

Figure 7. Install both Horizontal and Main Drain Pan Brackets (-042 through -060)

6. Remove two screws securing the blow-off prevention bracket. Rotate the brackets 180° and reinstall using the same screws. See figure 8.

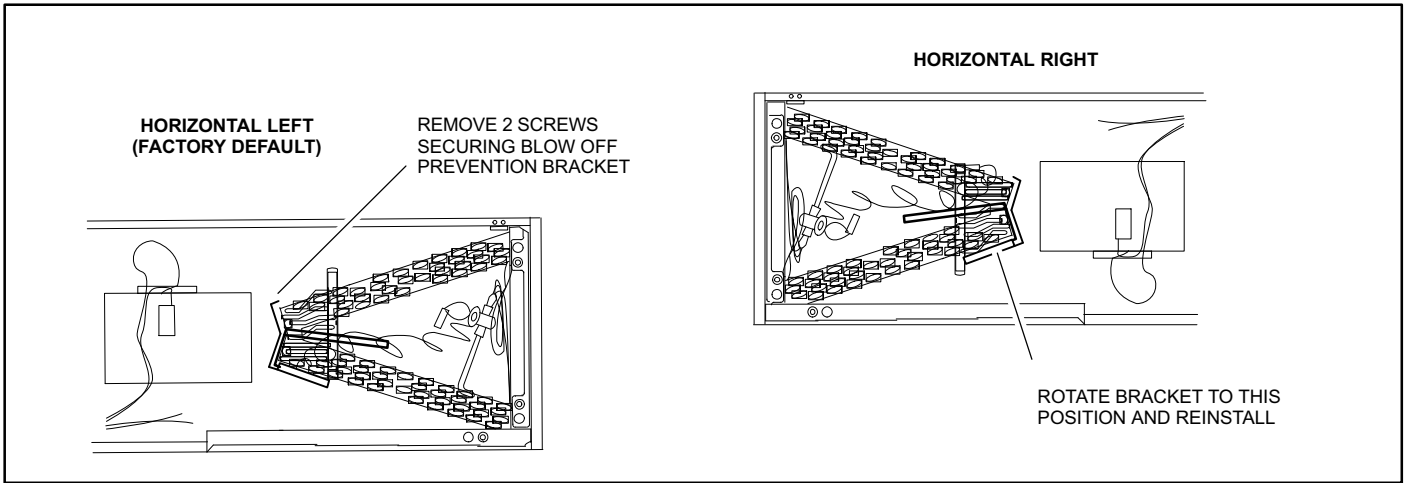

Figure 8. Blow-Off Prevention Plate

Condensate Drain

⚠ IMPORTANT

On units of this type, where the blower “draws” rather than “blows” air through the coil, traps must be installed in the condensate drain lines (primary and auxiliary, if used). Traps prevent the blower from drawing air through the drain lines into the air supply.

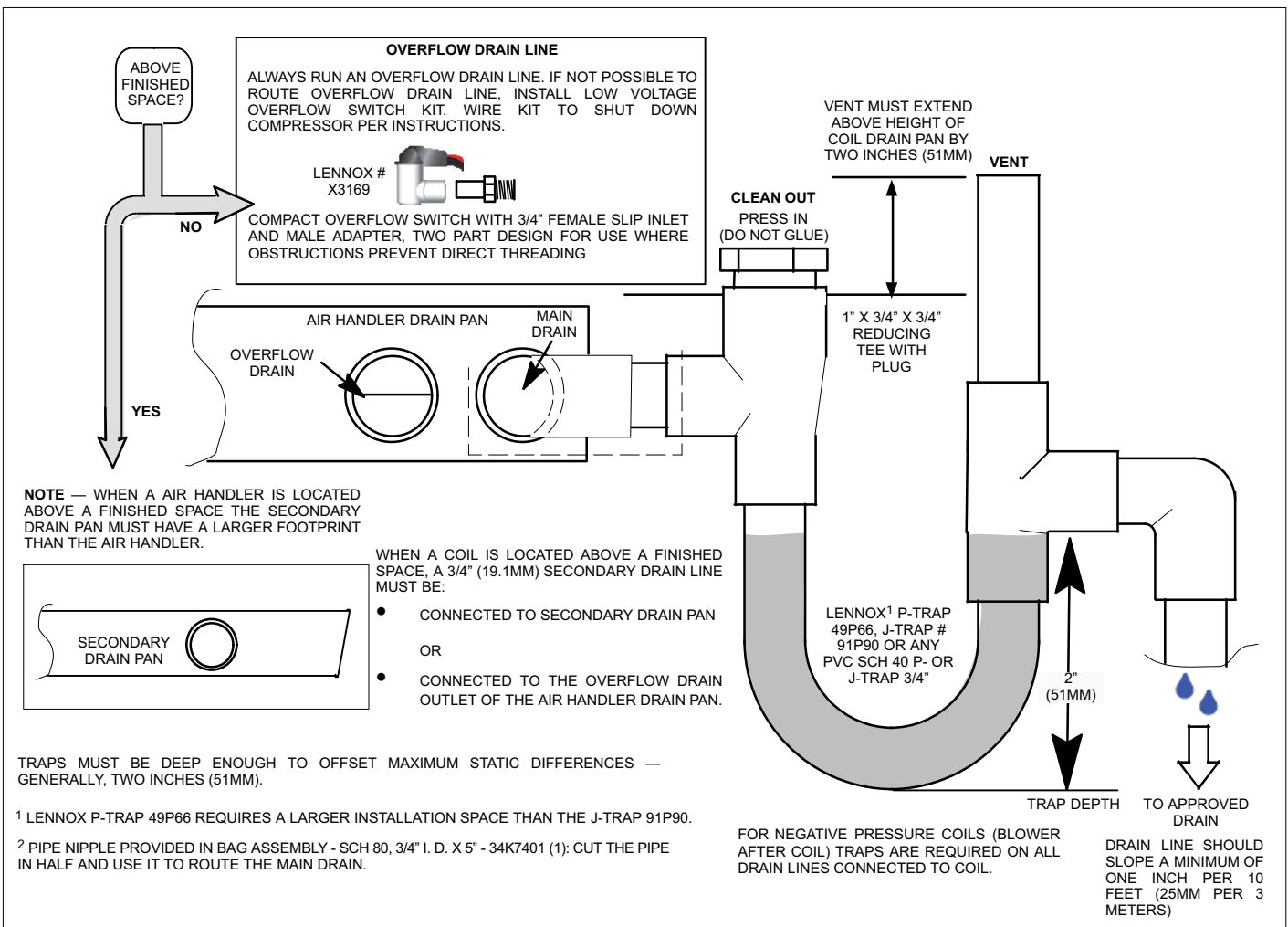

Figure 9. Typical Main and Overflow Drain

⚠ IMPORTANT

A field-fabricated secondary drain pan, with a drain pipe to the outside of the building, is required in all installations over a finished living space or in any area that may be damaged by overflow from the main drain pan. In some localities, local codes may require a secondary drain pan for any horizontal installation.

The air handler is provided with 3/4" NPT condensate drain connections.

SLOPING THE DRAIN

Make sure the unit is sloped (similar to the slope shown in figure 10) (horizontal or upflow) so that the drain pan will empty completely without water standing in the pan.

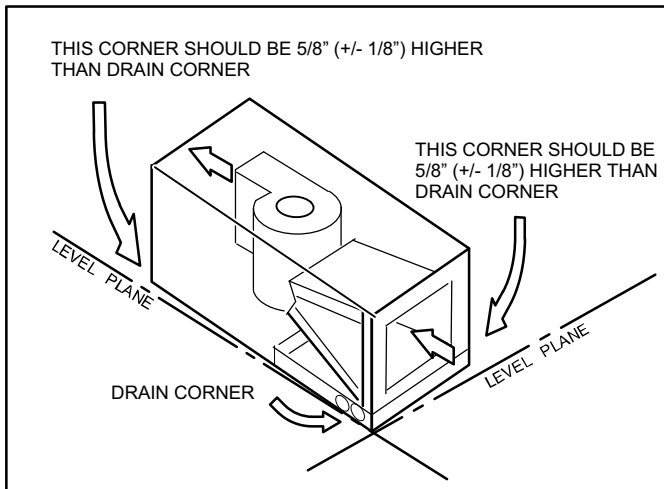

Figure 10. Sloping the Drain

INSTALL CONDENSATE DRAIN

1. Remove the appropriate drain knockouts. If necessary, remove the indoor coil assembly from the cabinet.
2. Connect primary drain line connection to the primary drain pan connection. The primary drain connection is flush with the bottom of the inside of the pan. Secondary connection is raised above the bottom of the inside of the pan.

NOTE — When making drain fitting connections to the drain pan, hand tighten the fitting and use a thread sealant. Over-tightening the fittings can split connections on the drain pan.

3. If the auxiliary drain line is to be used, remove the plug and route the drain line so that water draining from the outlet will be easily noticed by the homeowner. The auxiliary drain line does not require venting or a trap. Refer to local codes.
4. After removal of drain pan plugs, check the drain port to see if holes have been drilled. If not drilled, use a 19/32" bit to drill out the primary drain hole; use a 3/8" drill bit for the secondary drain hole. Remove all drill shavings.

5. Make sure drain ports and drain pan are free of all debris.
6. Plug and check any unused drain pan openings for tightness. Torque plugs to 30 in. lb. to prevent water leaks or seepage from the drain pan.
7. Install a 2" trap in the primary drain lines as close to the unit as practical (see figure 9). Make sure the top of the trap is below the connection to the drain pan to allow complete drainage of the pan.

NOTE — Horizontal runs must have an anti-siphon air vent (standpipe) installed ahead of the horizontal run (See figure 9). An extremely long horizontal run may require an oversized drain line to eliminate air trapping.

NOTE — Do not operate air handler without a drain trap. The condensate drain is on the negative pressure side of the blower; therefore, air being pulled through the condensate line will prevent positive drainage without a proper trap.

8. Route the drain line to the outside or to an appropriate drain. Drain lines must be installed so they do not block service access to the front of the air handler. A 24" clearance is required for filter, coil, or blower removal and service access.

NOTE — Check local codes before connecting the drain line to an existing drainage system.

Insulate the drain lines where sweating could cause water damage.

TEST CONDENSATE DRAIN

Test the drain pan and drain line after installation:

1. Pour several quarts of water into drain pan, enough to fill drain trap and line.
2. Check to make sure the drain pan is draining completely, no leaks are found in drain line fittings, and water is draining from the end of the primary drain line.
3. Correct any leaks found.

Duct System and Filters

DUCT SYSTEM

The air handler is provided with flanges for the connection of the plenum and ducts. The air handler is equipped with flanges that can form a filter rack for the installation of the air filter, or the filter may be installed as part of the return air duct system.

Supply and return duct system must be adequately sized to meet the system's air requirements and static pressure capabilities. The duct system should be insulated with a minimum of 1" thick insulation with a vapor barrier in conditioned areas or 2" minimum in unconditioned areas.

Table 1. Unit Air Filter Size Chart

Model	Filter Size	Actual Minimum Filter Size
-018	12" x 20" x 1	11.50" x 19.50" x .75"
-024 and -030	15" x 20" x 1	14.50" x 19.50" x .75"
-036	18" x 20" x 1	17.50" x 19.50" x .75"
-042, -048 and -060	18" x 24" x 1	17.50" x 23.50" x .75"

IMPORTANT

If a high-efficiency filter is being installed as part of this system to ensure better indoor air quality, the filter must be properly sized. High-efficiency filters have a higher static pressure drop than standard-efficiency glass/foam filters. If the pressure drop is too great, system capacity and performance may be reduced. The pressure drop may also cause the limit to trip more frequently during the winter and the indoor coil to freeze in the summer, resulting in an increase in the number of service calls.

Before using any filter with this system, check the specifications provided by the filter manufacturer against the data given in the appropriate Lennox Product Specifications bulletin. Additional information is provided in Service and Application Note ACC-00-2 (August 2000).

Supply plenum should be the same size as the flanged opening provided around the blower outlet and should extend at least 3 ft. from the air handler before turning or branching off plenum into duct runs. The plenum forms an extension of the blower housing and minimizes air expansion losses from the blower.

INSTALLING DUCT SYSTEM

Connect supply air duct to the flange on top of the air handler. If an isolation connector is used, it must be nonflammable.

A return air duct system is recommended. If the unit is installed in a confined space or closet, a return connection must be run, full size, to a location outside the closet.

Connecting Refrigerant Lines

Refrigerant lines must be connected by a qualified technician in accordance with established procedures.

IMPORTANT

Refrigerant lines must be clean, dehydrated, refrigerant-grade copper lines. Air handler coils should be installed only with specified line sizes for approved system combinations.

Handle the refrigerant lines gently during the installation process. Sharp bends or possible kinking in the lines will cause a restriction.

Do not remove the caps from the lines or system connection points until connections are ready to be completed.

1. Route the suction and liquid lines from the fittings on the indoor coil to the fittings on the outdoor unit. Run the lines in as direct a path as possible avoiding unnecessary turns and bends.

2. Make sure that the suction line is insulated over the entire exposed length and that neither suction nor liquid lines are in direct contact with floors, walls, duct system, floor joists, or other piping.
3. Connect the suction and liquid lines to the evaporator coil.
4. To avoid damaging the rubber grommets in the cabinet while brazing, slide the rubber grommets over the refrigerant lines until they are away from the heat source.
5. Braze using an alloy of silver or copper and phosphorus with a melting point above 1,100°F (593°C).

NOTE — Do not use soft solder.

6. Reinstall the rubber grommets after brazing is finished.
7. Make sure outdoor unit has been put in place according to the Installation Instructions and is connected to the refrigerant lines.

Sealing the Unit

Seal the unit so that warm air is not allowed into the cabinet. Warm air introduces moisture, which results in water blow-off problems. This is especially important when the unit is installed in an unconditioned area.

If installed in an unconditioned space, sealant should be applied around the electrical wires, refrigerant tubing, and condensate lines where they enter the cabinet.

WARNING

There must be an airtight seal between the bottom of the air handler and the return air plenum. Use fiberglass sealing strips, caulking, or equivalent sealing method between the plenum and the air handler cabinet to ensure a tight seal. Return air must not be drawn from a room where this air handler or any gas-fueled appliance (i.e., water heater), or carbon monoxide-producing device (i.e., wood fireplace) is installed.

IMPORTANT

When sealing the cabinet, be sure to seal closed any space around the holes where the drain lines exit the cabinet using duct tape and/or Permagem. Warm air must not be allowed to enter through any gaps or holes in the cabinet.

Make sure the liquid line and suction line entry points are sealed with either ARMAFLEX material or with Permagem. Permagem may also be used to seal around the main and auxiliary drains and around open areas of electrical inlets.

Electrical Connections

⚠ WARNING



Electric shock hazard! - Disconnect all power supplies before servicing.

Replace all parts and panels before operating.

Failure to do so can result in death or electrical shock.

⚠ WARNING

Electric Shock Hazard.

Can cause injury or death.

Foil-faced insulation has conductive characteristics similar to metal. Be sure there are no electrical connections within a 1/2" of the insulation. If the foil-faced insulation comes in contact with electrical voltage, the foil could provide a path for current to pass through to the outer metal cabinet. While the current produced may not be enough to trip existing electrical safety devices (e.g. fuses or circuit breakers), the current can be enough to cause an electric shock hazard that could cause personal injury or death.

- All field wiring must be done in accordance with National Electrical Code, applicable requirements of UL and local codes, where applicable.
- Electrical wiring, disconnect means and over-current protection are to be supplied by the installer. Refer to the air handler rating plate for maximum over-current protection, minimum circuit ampacity, as well as operating voltage.
- The power supply must be sized and protected according to the specifications supplied on the product.
- This air handler is factory-configured for 240 volt, single phase, 60 cycles. For 208-volt applications, see "208 Volt Conversion" later in this section.
- For optional field-installed electric heat applications, refer to the instructions provided with the accessory for proper installation.

⚠ WARNING

USE COPPER CONDUCTORS ONLY

1. Disconnect all power supplies.
2. Remove the air handler access panel.
3. Route the field supply wires to the air handler electrical connection box.
4. Use UL-listed wire nuts to connect the field supply conductors to the unit black and yellow leads, and the ground wire to ground terminal marked **GND**.
5. Replace the air handler access panel.

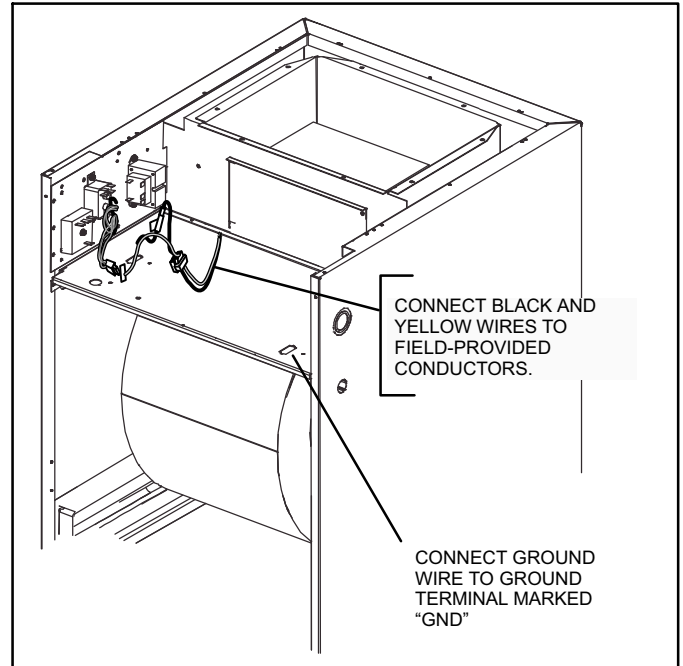

Figure 11. Making Electrical Connections

208 VOLT CONVERSION

1. Disconnect all power supplies.
2. Remove the air handler access panel.
3. Using the wiring diagram located on the unit access panel as a reference, move the 2 connected black transformer leads from the 240 volt terminal on the transformer to the 208 volt terminal on the transformer.

⚠ WARNING



Electrically ground air handler. Connect ground wire to ground terminal marked "GND".

Failure to do so can result in death or electrical shock.

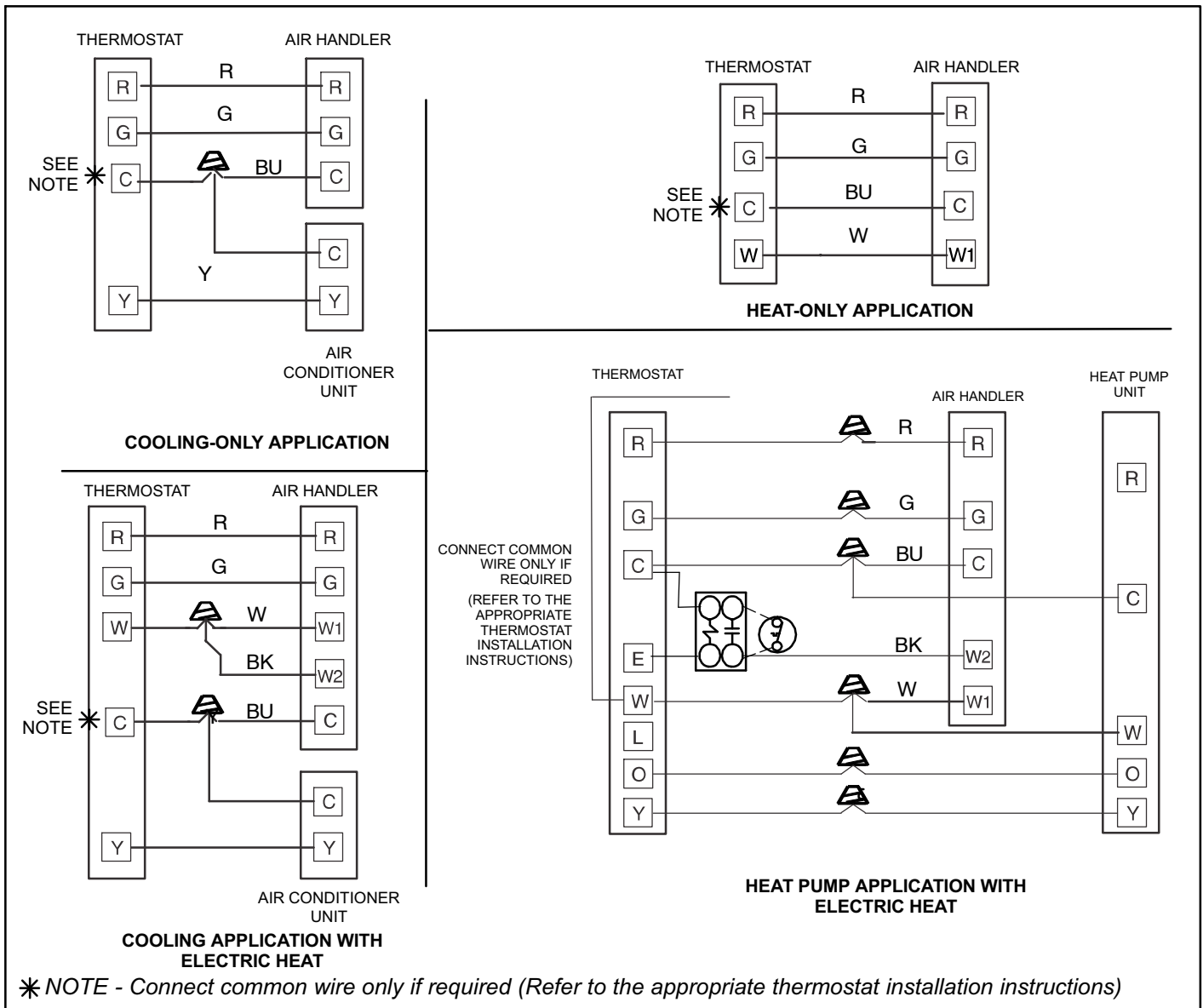

Figure 12. Low Voltage Connections (3-Speed PSC Motor) - Field Wiring

Airflow — Cooling Blower Speed

The cooling blower speed is factory configured to provide correct airflow for an outdoor unit that matches the cooling capacity rating of the air handler.

If the outdoor unit is smaller than the maximum cooling capacity rating for the air handler, the cooling blower speed may need to be changed. Refer to blower performance chart, table 2 on page 11 .

⚠ WARNING



Electric shock hazard! - Disconnect all power supplies before servicing.

Replace all parts and panels before operating.

Failure to do so can result in death or electrical shock.

CHANGE BLOWER SPEED

1. Disconnect all power supplies.
2. Remove the air handler access panel.
3. Locate pin number 2 on the blower relay. Two black wires are connected to this terminal pin. One connects to pin number 5 on the blower relay, one connects to an in-line splice connecting to a red wire.
4. Remove the wire going to the 4-pin blower motor connector from the splice.
5. Connect the blower lead [Red (LO), Black (HI)] onto the splice from the 4-pin blower motor connector.

NOTE — Reuse the factory-installed plastic cap on whichever wire is not used.

6. Replace all panels.
7. Reconnect power.

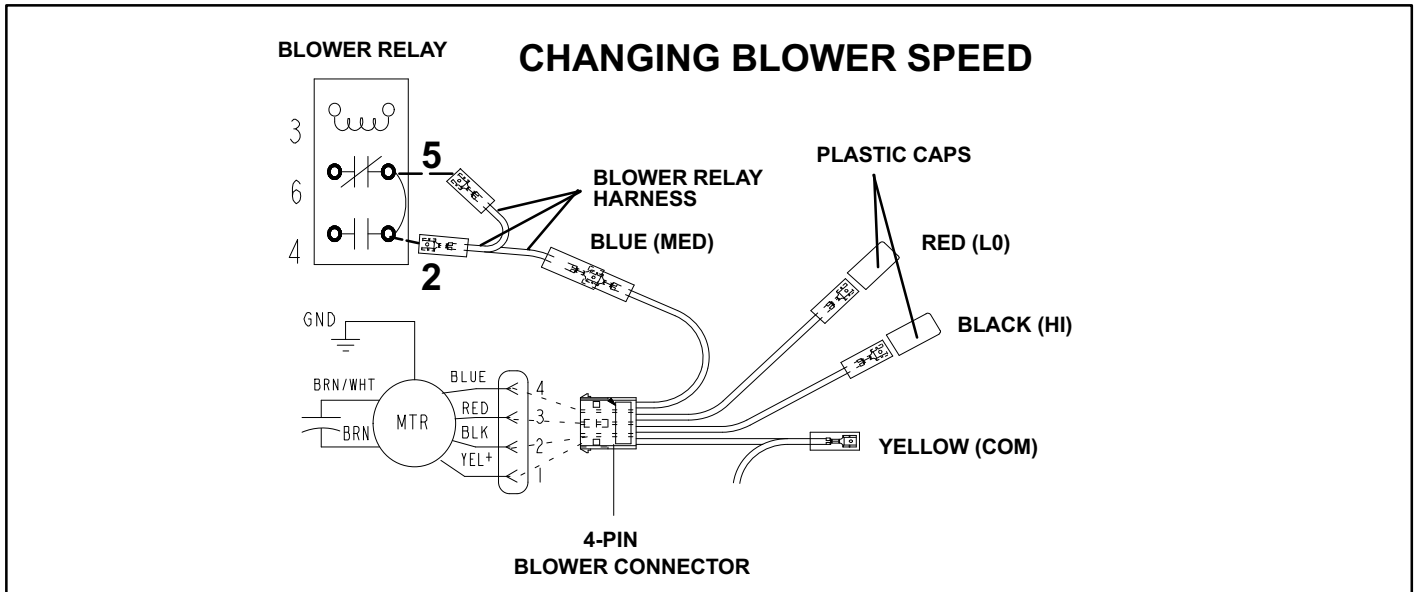

Figure 13. Changing Blower Speed

NOTE — Refer to wiring diagram located on the unit access panel (or figure 13 above) and blower performance (table 2).

- All air data measured external to unit with 1 inch non-pleated air filter in place.
- All factory settings are medium speed except the -48 which is set to low speed from the factory.
- All data given while air handler is operating with a dry DX coil.

Table 2. CBX25UH Blower Performance (3-Speed PSC) - 240V (CFM @ ESP. - in. W. C.)

Air Handler Model	Blower Speed	.10" WC	.20" WC	.30" WC	.40" WC	.50" WC
18	Low (Red)	510	495	475	420	325
	Med (Blue)	670	650	630	595	505
	High (Black)	905	865	820	770	705
24	Low (Red)	630	625	615	610	580
	Med (Blue)	885	875	850	820	780
	High (Black)	1130	1100	1070	1010	950
30	Low (Red)	900	865	830	780	740
	Med (Blue)	1075	1060	1030	985	940
	High (Black)	1240	1210	1170	1135	1085
36	Low (Red)	1160	1140	1115	1085	990
	Med (Blue)	1500	1445	1385	1300	1200
	High (Black)	1660	1575	1495	1405	1390
42	Low (Red)	1325	1315	1300	1275	1225
	Med (Blue)	1490	1465	1440	1395	1315
	High (Black)	1820	1770	1690	1600	1500
48	Low (Red)	1775	1710	1645	1565	1470
	Med (Blue)	1995	1895	1800	1685	1560
	High (Black)	2070	1970	1850	1719	1595
60	Low (Red)	1675	1630	1580	1520	1450
	Med (Blue)	1965	1925	1875	1800	1695
	High (Black)	2140	2085	2000	1895	1795

- Blower Performance (CFM vs. ESP inches H2O)
- Cooling speeds should not be reduced below factory setting.
- Units with electric heat approved at 0.5" maximum and medium blower speed minimum.

Check-out Procedures

NOTE - Refer to outdoor unit installation instructions for system start-up instructions and refrigerant charging instructions.

PRE-START-UP CHECKS

- Is the air handler properly and securely installed?
- If horizontally configured, is the unit sloped up to 5/8 inch toward drain lines?
- Will the unit be accessible for servicing?
- Has an auxiliary pan been provided under the unit with separate drain for units installed above a finished ceiling or in any installation where condensate overflow could cause damage?
- Have ALL unused drain pan ports been properly plugged?
- Has the condensate line been properly sized, run, trapped, pitched, and tested?
- Is the duct system correctly sized, run, sealed, and insulated?
- Have all cabinet openings and wiring been sealed?
- Is the indoor coil factory-installed TXV properly sized for the outdoor unit being used?
- Have all unused parts and packaging been disposed of?
- Is the filter clean, in place, and of adequate size?
- Is the wiring neat, correct, and in accordance with the wiring diagram?
- Is the unit properly grounded and protected (fused)?
- Is the thermostat correctly wired and in a good location?
- Are all access panels in place and secure?

CHECK BLOWER OPERATION

- Set thermostat to FAN ON.
- The indoor blower should come on.

CHECK COOLING OPERATION

- Set thermostat to force a call for cooling (approximately 5°F lower than the indoor ambient temperature).
- The outdoor and indoor units should come on immediately.
- Check the airflow from a register to confirm that the system is moving cooled air.
- Set the thermostat 5°F higher than the indoor temperature. The indoor blower and outdoor unit should cycle off. Air handler should cycle off 45 seconds after the outdoor unit shuts off.

CHECK ELECTRIC HEATER (IF USED)

- Set thermostat to call for auxiliary heat (approximately 5°F above ambient temperature). The indoor blower and auxiliary heat should come on together. Allow a minimum of 3 minutes for all sequencers to cycle on.

- Set the thermostat so that it does not call for heat. Allow up to 5 minutes for all sequencers to cycle off.

Operation

TIME DELAY RELAY

Blower time delay operation:

1. When cooling demand is initiated, there is a 1 second motor-on delay.
2. After the motor-on delay expires, motor ramps up to 100% and runs at 100% until cooling demand is satisfied.
3. Once demand is met, motor runs at 100% for 45 seconds.
4. Motor ramps down to stop.

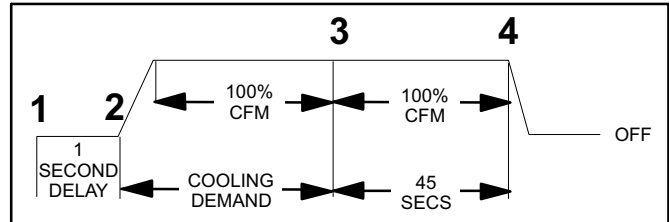

Figure 14. Blower Time Delay

COOLING (COOLING ONLY OR HEAT PUMP)

When the thermostat calls for cooling, 24 volts is put on the blower time-delay relay coil and then the indoor blower relay energizes. The normally open contacts close, causing the indoor blower motor to operate. The circuit between **R** and **Y** is completed, closing the circuit to the contactor in the outdoor unit, starting the compressor and outdoor fan motor.

On heat pumps, circuit **R** and **O** energizes the reversing valve, switching the valve to the cooling position. (The reversing valve remains energized as long as the thermostat selector switch is in the **COOL** position.)

At the completion of the cooling demand the indoor blower and outdoor unit should cycle off. Air handler should cycle off 45 seconds after the outdoor unit shuts off.

HEATING (ELECTRIC HEAT ONLY)

When the thermostat calls for heat, the circuit between **R** and **W** is completed, and the heat sequencer is energized. A time delay follows before the heating elements and the indoor blower motor come on. Units with a second heat sequencer can be connected with the first sequencer to **W** on the thermostat subbase, or they may also be connected to a second stage on the subbase.

HEATING (HEAT PUMP)

When the thermostat calls for heating, 24 volts is put on the blower time-delay relay coil. Then normally open contacts close, causing the indoor blower motor to operate. The circuit between **R** and **Y** is completed, closing the circuit to the contactor in the outdoor unit, starting the compressor and outdoor fan motor.

If the room temperature should continue to fall, the circuit between **R** and **W1** is completed by the second-stage heat room thermostat. Circuit **R-W1** energizes a heat sequencer. The completed circuit will energize supplemental electric heat (if applicable). Units with a

second heat sequencer can be connected with the first sequencer to **W1** on the thermostat. They may also be connected to a second heating stage **W2** on the thermostat subbase.

EMERGENCY HEAT (HEATING HEAT PUMP)

If the selector switch on the thermostat is set to the emergency heat position, the heat pump will be locked out of the heating circuit, and all heating will be electric heat (if applicable). A jumper should be placed between **W2** and **E** on the thermostat subbase so that the electric heat control will transfer to the first-stage heat on the thermostat. This will allow the indoor blower to cycle on and off with the electric heat when the fan switch is in the AUTO position.

Maintenance

⚠ IMPORTANT

Do not operate system without a filter. A filter is required to protect the coil, blower, and internal parts from excessive dirt and dust. The filter is placed in the return duct by the installer.

- Inspect air filters at least once a month and replace or clean as required. Dirty filters are the most common cause of inadequate heating or cooling performance.
- Replace disposable filters. Cleanable filters can be cleaned by soaking in mild detergent and rinsing with cold water.
- Install new/clean filters with the arrows on the side pointing in the direction of airflow. Do not replace a cleanable (high velocity) filter with a disposable (low velocity) filter unless return air system is properly sized for it.
- If water should start coming from the secondary drain line, a problem exists which should be investigated and corrected. Contact a qualified service technician.

Cabinet Insulation

⚠ IMPORTANT

DAMAGED INSULATION MUST BE REPAIRED OR REPLACED before the unit is put back into operation. Insulation loses its insulating value when wet, damaged, separated or torn.

Matt- or foil-faced insulation is installed in indoor equipment to provide a barrier between outside air conditions (surrounding ambient temperature and humidity) and the varying conditions inside the unit. If the insulation barrier is damaged (wet, ripped, torn or separated from the cabinet walls), the surrounding ambient air will affect the inside surface temperature of the cabinet. The temperature/humidity difference between the inside and outside of the cabinet can cause condensation on the inside or outside of the cabinet which leads to sheet metal corrosion and subsequently, component failure.

REPAIRING DAMAGED INSULATION

Areas of condensation on the cabinet surface are an indication that the insulation is in need of repair.

If the insulation in need of repair is otherwise in good condition, the insulation should be cut in an X pattern, peeled open, glued with an appropriate all-purpose glue and placed back against the cabinet surface, being careful to not overly compress the insulation so the insulation can retain its original thickness. If such repair is not possible, replace the insulation. If using foil-faced insulation, any cut, tear, or separations in the insulation surface must be taped with a similar foil-faced tape.

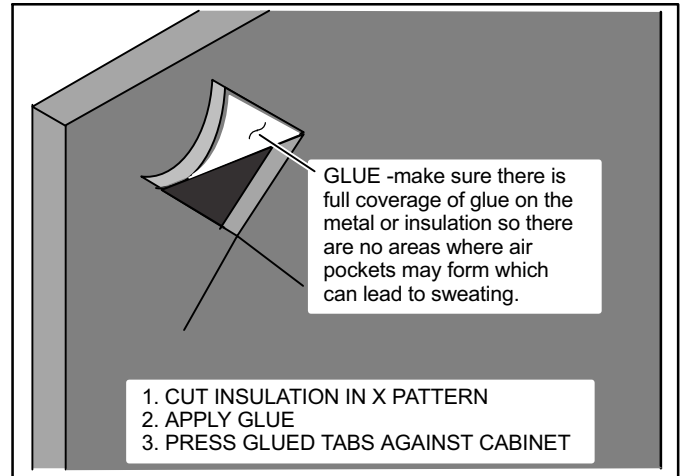
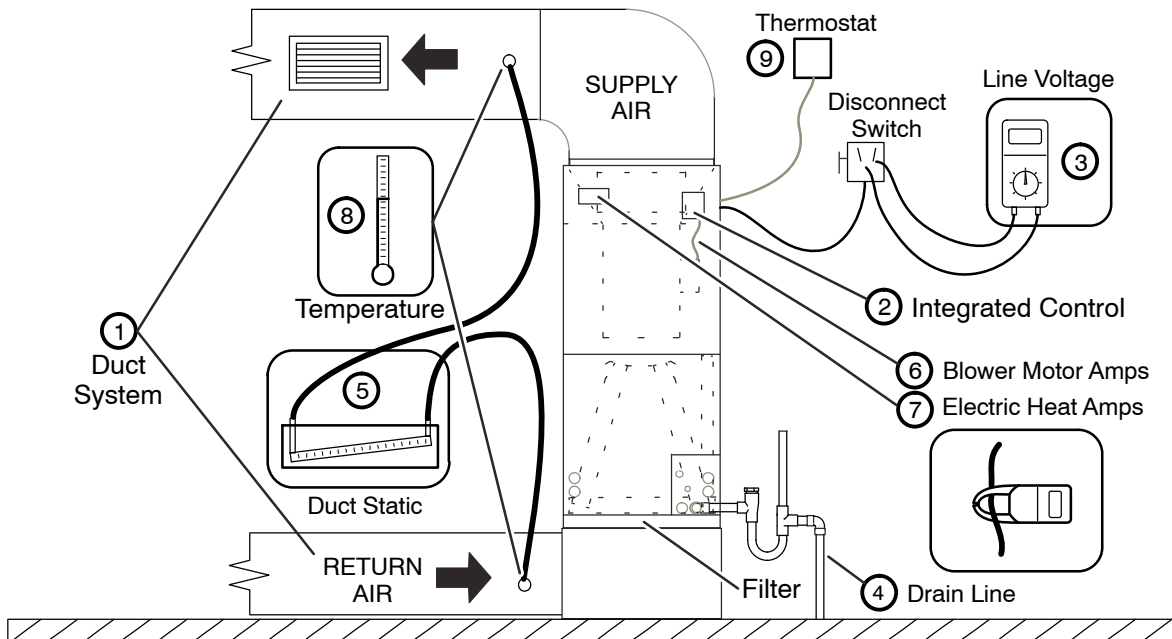

Figure 15. Repairing Insulation

Installing Contractor's Name _____
 Installing Contractor's Phone _____
 Job Address _____

Installing Date _____
 Air Handler Model # _____



- | | |
|--|---|
| <p>① DUCT SYSTEM</p> <p>SUPPLY AIR DUCT</p> <p><input type="checkbox"/> Sealed</p> <p><input type="checkbox"/> Insulated (if necessary)</p> <p><input type="checkbox"/> Registers Open and Unobstructed</p> <p>RETURN AIR DUCT</p> <p><input type="checkbox"/> Sealed</p> <p><input type="checkbox"/> Filter Installed and Clean</p> <p><input type="checkbox"/> Registers Open and Unobstructed</p> <p>② INTEGRATED CONTROL</p> <p><input type="checkbox"/> Jumpers Configured Correctly (if applicable)</p> <p><input type="checkbox"/> Appropriate Links in Place (if applicable)</p> <p>③ VOLTAGE CHECK</p> <p><input type="checkbox"/> Supply Voltage _____</p> <p><input type="checkbox"/> Low Voltage _____</p> <p><input type="checkbox"/> Electrical Connections Tight</p> <p>④ DRAIN LINE</p> <p><input type="checkbox"/> Leak Free</p> <p><input type="checkbox"/> Explained Operation of System to Homeowner</p> | <p>⑤ TOTAL EXTERNAL STATIC (dry coil)</p> <p style="text-align: right;">dry coil wet coil</p> <p>Supply External Static _____</p> <p>Return External Static _____</p> <p>Total External Static = _____</p> <p>⑥ ELECTRIC HEAT AMPS _____</p> <p>⑦ INDOOR BLOWER AMPS _____</p> <p>INDOOR BLOWER CFM _____</p> <p>⑧ TEMPERATURE DROP (Cooling Mode)</p> <p>Return Duct Temperature _____</p> <p>Supply Duct Temperature - _____</p> <p>Temperature Drop = _____</p> <p>⑧ TEMPERATURE RISE (Heating Mode)</p> <p>Return Duct Temperature _____</p> <p>Supply Duct Temperature - _____</p> <p>Temperature Rise = _____</p> <p>⑨ THERMOSTAT</p> <p><input type="checkbox"/> Adjusted and Programmed</p> <p><input type="checkbox"/> Operation Explained to Owner</p> |
|--|---|

Technician's Name: _____ Date Start-Up & Performance Check Completed _____

Figure 16. Start-Up and Performance Checklist (Upflow Configuration)

Installing Contractor's Name _____
 Installing Contractor's Phone _____
 Job Address _____

Installing Date _____
 Air Handler Model # _____

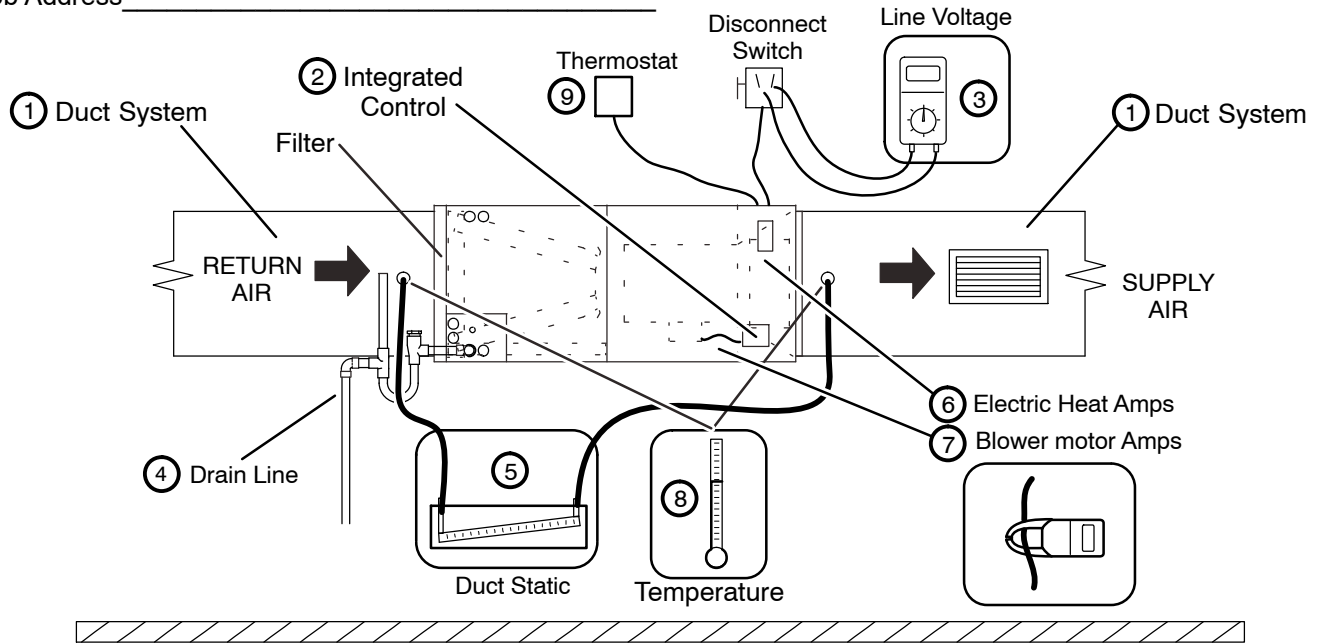

- | | |
|--|---|
| <p>① DUCT SYSTEM
 SUPPLY AIR DUCT</p> <p><input type="checkbox"/> Sealed</p> <p><input type="checkbox"/> Insulated (if necessary)</p> <p><input type="checkbox"/> Registers Open and Unobstructed</p> <p>RETURN AIR DUCT</p> <p><input type="checkbox"/> Sealed</p> <p><input type="checkbox"/> Filter Installed and Clean</p> <p><input type="checkbox"/> Registers Open and Unobstructed</p> <p>② INTEGRATED CONTROL</p> <p><input type="checkbox"/> Jumpers Configured Correctly (if applicable)</p> <p><input type="checkbox"/> Appropriate Links in Place (if applicable)</p> <p>③ VOLTAGE CHECK</p> <p><input type="checkbox"/> Supply Voltage _____</p> <p><input type="checkbox"/> Low Voltage _____</p> <p><input type="checkbox"/> Electrical Connections Tight</p> <p>④ DRAIN LINE</p> <p><input type="checkbox"/> Leak Free</p> <p><input type="checkbox"/> Explained Operation of System to Homeowner</p> | <p>⑤ TOTAL EXTERNAL STATIC (dry coil)</p> <p style="text-align: right;">dry coil wet coil</p> <p>Supply External Static _____</p> <p>Return External Static _____</p> <p>Total External Static = _____</p> <p>⑥ ELECTRIC HEAT AMPS _____</p> <p>⑦ INDOOR BLOWER AMPS _____</p> <p>INDOOR BLOWER CFM _____</p> <p>⑧ TEMPERATURE DROP (Cooling Mode)</p> <p>Return Duct Temperature _____</p> <p>Supply Duct Temperature - _____</p> <p>Temperature Drop = _____</p> <p>⑧ TEMPERATURE RISE (Heating Mode)</p> <p>Return Duct Temperature _____</p> <p>Supply Duct Temperature - _____</p> <p>Temperature Rise = _____</p> <p>⑨ THERMOSTAT</p> <p><input type="checkbox"/> Adjusted and Programmed</p> <p><input type="checkbox"/> Operation Explained to Owner</p> |
|--|---|

Technician's Name: _____ Date Start-Up & Performance Check Completed _____

Figure 17. Start-Up and Performance Checklist (Horizontal Configuration)

