

Lang[®]

ENVIROZONE-TSTAT GAS GRIDDLE

Commercial

224ZT, 236ZT, 248ZT, 260ZT, 272ZT

Installation and Operation Instructions

2M-W1785 Rev. D 03/18

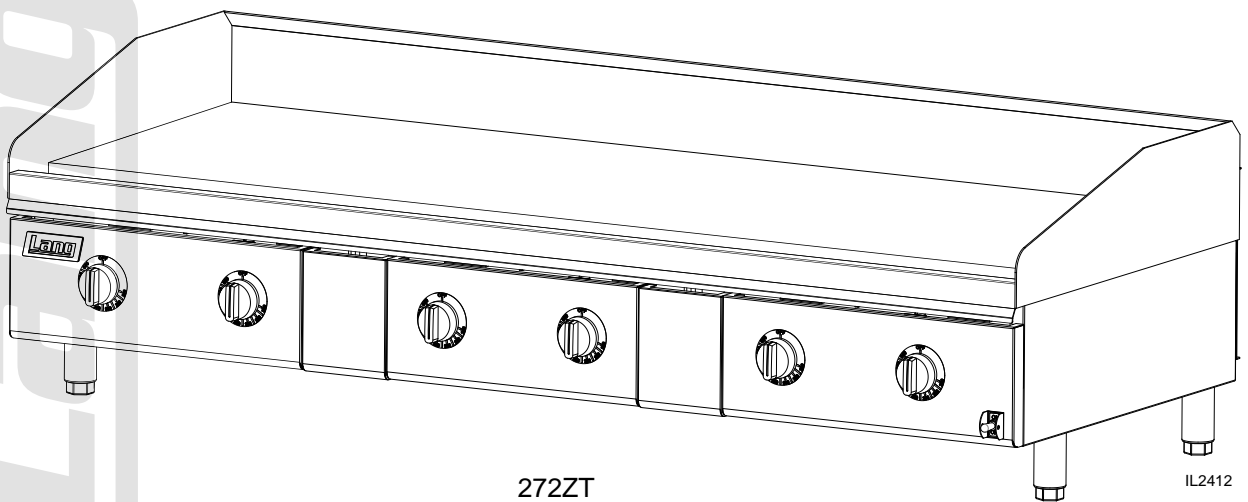

272ZT

IL2412



SAFETY SYMBOL



These symbols are intended to alert the user to the presence of important operating and maintenance instructions in the manual accompanying the appliance.

FOR YOUR SAFETY

DO NOT STORE OR USE GASOLINE OR OTHER FLAMMABLE VAPORS AND LIQUIDS IN THE VICINITY OF THIS OR ANY OTHER APPLIANCE.

The installation of the Appliance must conform to the NATIONAL FUEL GAS CODE "ANSI Z223.1 - LATEST EDITION" AND ALL LOCAL GAS COMPANY RULES AND REGULATIONS.

IN CANADA INSTALLATION SHALL BE IN ACCORDANCE WITH THE CURRENT CAN/CGA-B149.1 NATURAL GAS INSTALLATION CODE OR CAN/CGA-B149.2 PROPANE INSTALLATION CODE AND LOCAL CODES WHERE APPLICABLE.

POST IN PROMINENT LOCATION

INSTRUCTIONS TO BE FOLLOWED IN THE EVENT USER SMELLS GAS. THIS INFORMATION SHALL BE OBTAINED BY CONSULTING YOUR LOCAL GAS SUPPLIER. AS A MINIMUM, TURN OFF THE GAS AND CALL YOUR GAS COMPANY AND YOUR AUTHORIZED SERVICE AGENT. EVACUATE ALL PERSONNEL FROM THE AREA.

WARNING

IMPROPER INSTALLATION, ADJUSTMENT, ALTERATION, SERVICE OR MAINTENANCE CAN CAUSE PROPERTY DAMAGE, INJURY OR DEATH. READ THE INSTALLATION, OPERATION & MAINTENANCE INSTRUCTIONS THOROUGHLY BEFORE INSTALLING OR SERVICING THIS EQUIPMENT.

WARNING



**RISK OF FIRE OR ELECTRIC SHOCK
DO NOT OPEN**



**WARNING, TO REDUCE THE RISK OF ELECTRICAL SHOCK, DO NOT REMOVE CONTROL PANEL. NO USER-SERVICABLE PARTS INSIDE.
REPAIRS SHOULD BE DONE BY AUTHORIZED SERVICE PERSONNEL ONLY.**

NOTICE

Using any part other than genuine Lang factory supplied parts relieves the manufacturer of all liability.

Lang reserves the right to change specifications and product design without notice. Such revisions do not entitle the buyer to corresponding changes, improvements, additions or replacements for previously purchased equipment.

Due to periodic changes in designs, methods, procedures, policies and regulations, the specifications contained in this sheet are subject to change without notice. While Lang Manufacturing exercises good faith efforts to provide information that is accurate, we are not responsible for errors or omissions in information provided or conclusions reached as a result of using the specifications. By using the information provided, the user assumes all risks in connection with such use.

MAINTENANCE AND REPAIRS

Contact your local dealer for service or required maintenance. Please record the model number, serial number, voltage and purchase & Installation Information in the area below and have it ready when you call to ensure a faster service.

Model No.: _____

Purchased From: _____

Serial No.: _____

Location: _____

Voltage: _____

Purchase Date: _____

1-Phase or 3 Phase: _____

Installed Date: _____



PROBLEMS, QUESTIONS or CONCERNS

Before you proceed consult you authorized Lang service agent directory

or

Call the Lang Technical Service Department at (314) 678-6315

TABLE OF CONTENTS

Specifications	4
Equipment Description	5
Unpacking	6
Installation	
Leg Installation	6
Ventilation & Clearence	7
Electrical & Gas Connection.	8
Initial Start-Up	
Initial Lighting Procedure	9
Seasoning Cooking Surface.	9
Operation	
Setting the Griddle Temperature	10
Suggested Times and Temperatures	10
Loading the Griddle	11
Sequence of Operation	
Power On	11
Maintenance	
Daily Cleaning	12
Weekly Cleaning	12
Burner Air Shutter Adjustment.	12
Calibration	13
Troubleshooting	
Symptoms / Possible Causes / Test.	14
Wiring Diagram	15 - 17
Exploded View & Parts List	18-23

NOTICE

Service on this or any other Lang appliance must be performed by qualified personnel only. Consult your Lang Authorized Service Agent Directory. You can call technical service at (314) 678-6315 or visit our website WWW.LANGWORLD.COM for the service agent nearest you.

EQUIPMENT SPECIFICATIONS

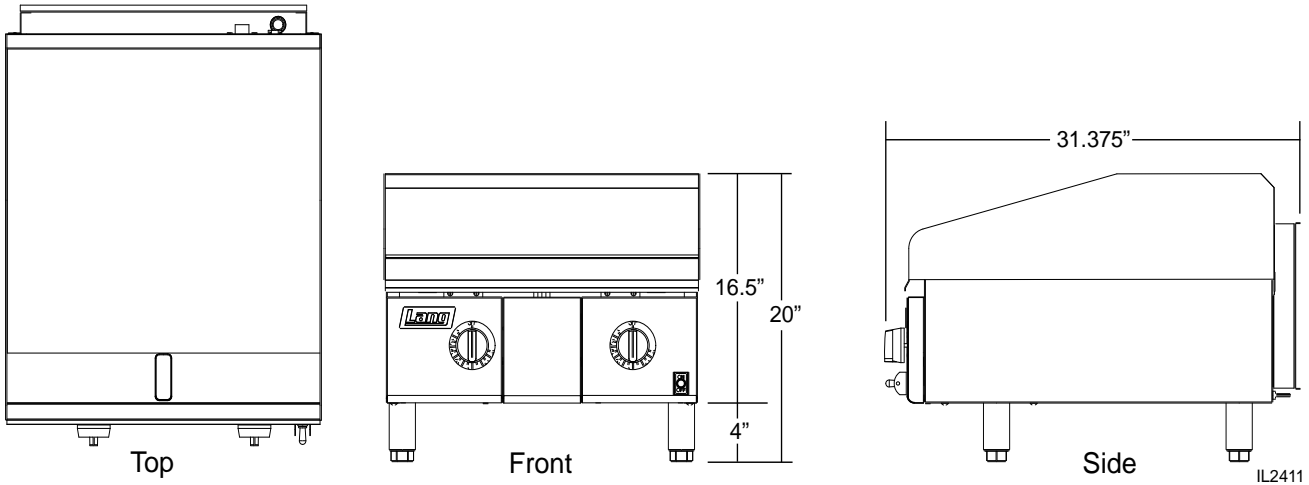

GAS AND ELECTRIC INPUT REQUIRMENTS

MODEL NUMBER	DESCRIPTION		TOTAL BTU INPUT		GAS CONNECTION	ELECTRICAL CONNECTION		CORD/PLUG & PRESSURE REGULATOR
	Unit Width	Griddle Surface Depths	NATURAL 5" WC	PROPANE 10" WC		VOLTAGE	AMPS	
224ZT	24"	24"	54,000	54,000	ONE 3/4" NPT	115 VOLT	2	SUPPLIED
224ZTD		30"	70,000	70,000				
236ZT	36"	24"	81,000	81,000				
236ZTD		30"	105,000	105,000				
248ZT	48"	24"	108,000	108,000				
248ZTD		30"	140,000	140,000				
260ZT	60"	24"	135,000	135,000				
260ZTD		30"	175,000	175,000				
272ZT	72"	24"	162,000	162,000				
272ZTD		30"	210,000	210,000				

SPECIFICATIONS AND INFORMATION

MODEL NUMBER	GRILL SURFACE OVERALL		SQUARE INCHES OF GRIDDLE	NUMBER OF BURNERS	NUMBER OF CONTROLS	NUMBER OF GREASE DRAWERS	CLEARANCE FROM NON-COMBUSTIBLE SURFACES			WEIGHT	
	WIDTH	DEPTH					SIDES	BACK	BOTTOM	ACTUAL	SHIPPING
224ZT	24"	23"	552	2	2	1	0"	5"	4 INCH LEG	255	300
224ZTD		30"	720								
236ZT	36"	23"	828	3	3	1	0"	5"	4 INCH LEG	336	400
236ZTD		30"	1,080								
248ZT	48"	23"	1,104	4	4	2	0"	5"	4 INCH LEG	435	500
248ZTD		30"	1,440								
248TDC											
260ZT	60"	23"	1,380	5	5	2	0"	5"	4 INCH LEG	530	625
260ZTD		30"	1,800								
272ZT	72"	23"	1,656	6	6	2	0"	5"	4 INCH LEG	610	725
272ZTD		30"	2,160								

LIMITED EQUIPMENT WARRANTY

Lang Manufacturing [as well as its subsidiaries] warranties new products to be free from defects in material and/or workmanship for a period of one [1] year from the date of original installation, except as noted below. Defects that occur as a result of normal use, within the time period and limitations defined in this warranty, will at Lang's discretion have the parts replaced or repaired by Lang or a Lang-authorized service agency.

THIS WARRANTY IS SUBJECT TO ALL LISTED CONDITIONS.

Repairs performed under this warranty are to be performed by a Lang-authorized service agency. Lang will not be responsible for charges incurred or service performed by non-authorized repair agencies. In all cases, the nearest Lang-authorized service agency must be used.

Lang will be responsible for normal labor charges incurred in the repair or replacement of a warrantied product within 50 miles (80.5 km) of an authorized service agency. Time and expense charges for anything beyond that distance will be the responsibility of the owner. All labor will need to be performed during regular service hours. Any overtime premium will be charged to the owner. For all shipments outside the U.S.A. and Canada, please see the International Warranty for specific details.

It is the responsibility of the owner to inspect and report any shipping damage claims, hidden or otherwise, promptly following delivery.

No mileage or travel charges will be honored on any equipment that is deemed portable. In general, equipment with a cord and plug weighing less than 50 lb. (22.7 kg) is considered portable and should be taken or shipped to the closest authorized service agency, transportation prepaid.

CONTACT

Should you require any assistance regarding the operation or maintenance of any Lang equipment; write, phone, fax or email our service department. In all correspondence mention the model number and the serial number of your unit, as well as the voltage or type of gas you are using.

Business hours are 8:00 a.m. to 4:30 p.m. Central Standard Time

Telephone 314.678.6315

Fax 314.781.2714

Email customerservice@star-mfg.com

www.langworld.com

WARRANTY EXCLUSIONS

THE FOLLOWING WILL NOT BE COVERED UNDER WARRANTY.

- Any product which has not been used, cleaned, maintained, or installed in accordance with the directions published in the appropriate installation sheet and/or owner's manual as well as national and local codes, including incorrect gas, electrical, or water connection. Lang is not liable for any unit which has been mishandled, abused, misapplied, subjected to chlorides, harsh chemicals, or caustic cleaners, damaged from exposure to hard water, modified by unauthorized personnel, damaged by flood, fire, or other acts of nature [or God], or which have an altered or missing serial number.
- Installation, labor, and job checkouts, calibration of heat controls, air and gas burner/bypass/pilot adjustments, gas or electrical system checks, voltage and phase conversions, cleaning of equipment, or seasoning of griddle surface.
- Replacement of fuses or resetting of circuit breakers, safety controls, or reset buttons.
- Replacement of broken or damaged glass components, quartz heating elements, and light bulbs.
- Labor charges for all removable parts in gas charbroilers and hotplates, including but not limited to burners, grates, and radiants.
- Any labor charges incurred by delays, waiting time, or operating restrictions that hinder a service technician's ability to perform service.
- Parts that fail or are damaged due to normal wear or labor for replacement of Items that can easily be replaced during a daily cleaning routine. such as but not limited to silicone belts, PTFE non-stick sheets, knobs, control labels, bulbs, fuses, quartz heating elements, baskets, racks, and grease drawers.
- Components that should be replaced when damaged or worn, but have been field-repaired instead [eg. field-welded fry pots]
- Any loss of business or profits.

ADDITIONAL WARRANTIES

Specialty/chain specific versions may also have additional and/or extended warranties.

PRODUCTS	PARTS	LABOR
Lang Chef-Series™ convection ovens	2 years	2 years
Lang Strato-Series™ convection ovens	2 years	2 years
Lang convection oven doors [excluding hardware]	lifetime	2 years
Lang griddles and charbroilers	2 years	2 years
chrome griddle surfaces [against peeling]	5 years	
cast iron grates, burners, and burner shields	180 days	
original Lang parts sold to repair Lang equipment	90 days	
Service First	1 year	

UNPACKING

Receiving the Griddle

Upon receipt, check for freight damage, both visible and concealed. Visible damage should be noted on the freight bill at the time of delivery and signed by the carrier's agent. Concealed loss or damage means it does not become apparent until the merchandise has been unpacked. If concealed loss or damage is discovered upon unpacking, make a written request for inspection by the carrier's agent within 15 days of delivery. All packing material should be kept for inspection. **DO NOT return damaged merchandise to Lang Manufacturing. File your claim with the carrier.**



Location

Prior to un-crating, move the griddle as near to its intended location as practical. The crating will help protect the unit from the physical damage normally associated with moving it through hallways and doorways.

Un-crating

The griddle will arrive completely assembled inside a wood frame and strapped to a skid. Cut the straps and remove the wood frame.

The griddle can now be removed from the skid.



THE UNIT IS EXTREMELY HEAVY. FOR SAFE HANDLING, INSTALLER SHOULD OBTAIN HELP AS NEEDED, OR EMPLOY APPROPRIATE MATERIALS HANDLING EQUIPMENT (SUCH AS A FORKLIFT, DOLLY, OR PALLET JACK) TO REMOVE THE UNIT FROM THE SKID AND MOVE IT TO THE PLACE OF INSTALLATION.

ANY STAND, COUNTER OR OTHER DEVICE ON WHICH GRIDDLE WILL BE LOCATED MUST BE DESIGNED TO SUPPORT THE WEIGHT OF THE GRIDDLE. SHIPPING STRAPS ARE UNDER TENSION AND CAN SNAP BACK WHEN CUT.

LEG INSTALLATION

The legs are installed by sliding the threaded ends of the legs into the leg receiver tubes located in each corner of the griddle.

Slide the leg up until contact is made with the threaded nut at the top of the receiver tube. Screw the leg counter-clockwise until it is hand tight.

After the griddle is in its final position, adjust the legs to create 1/8 inch slant from back to front. This will allow the grease to run into the front grease gutter and provide the proper combustion air for the burners. It will also allow exposed gasses to escape out the rear of the unit.

Level unit by adjusting the (4) legs for accurate and perfect lineup with other units.

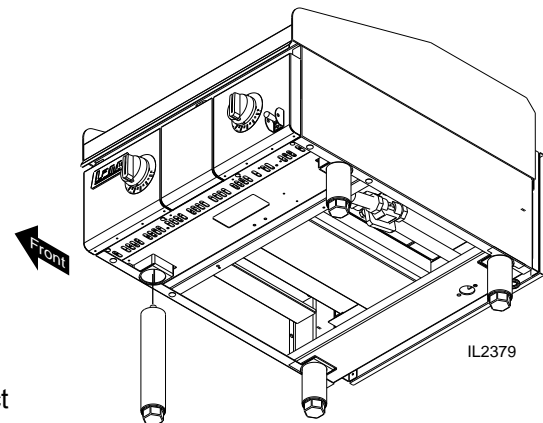

VENTILATION & CLEARANCE

CLEARANCE

For use on non-combustible countertops only.

Combustible and non-combustible material must be at least 48" (120cm) from the top of the appliance. Combustible material must be 5" (150mm) from the sides and back, while clearance to non-combustible material on the sides and back is 0". Adequate clearance should also be provided for proper operation and servicing.

AIR SUPPLY

Make certain not to obstruct the flow of combustion and ventilation air. Provisions for adequate air supply must be furnished. The legs supplied with the unit must be installed. Make certain that air intake openings in the bottom of the appliance are not obstructed. They are essential for proper combustion and operation of the appliance.

EXHAUST CANOPY

It is essential that facilities be provided over the griddle to carry off fumes and gases. However, the unit should not be directly connected to a flue or stack.

EQUIPMENT DESCRIPTION

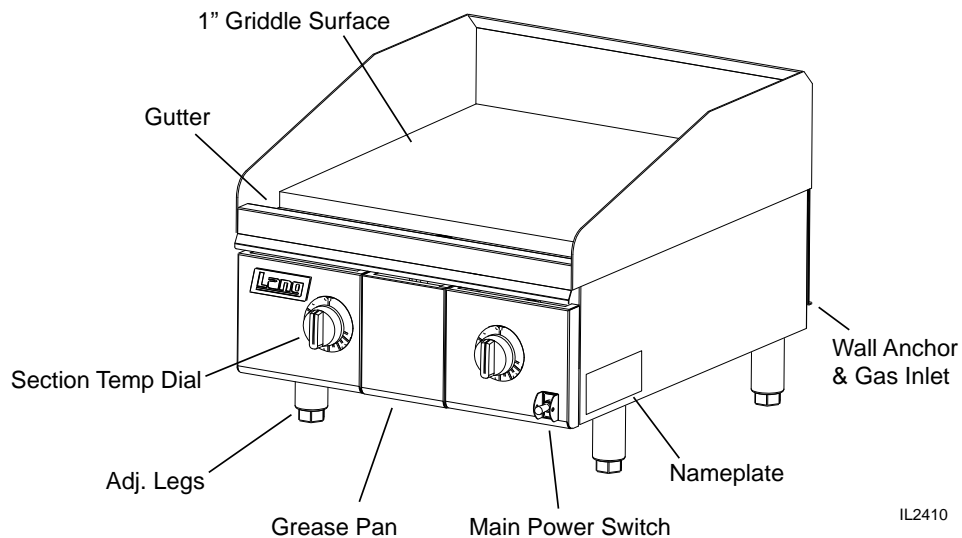

NOTICE The data plate is on the right side of the griddle. The voltage, wattage, serial number, wire size, and clearance specifications are on the data plate. This information should be carefully read and understood before proceeding with the installation.

INSTALLATION

Electrical Connection

The griddle is supplied with a cord and plug. The receptacle is not provided with the griddle.

Follow the receptacle manufacturer's instructions when connecting the receptacle to the power supply.

Gas Connection

This griddle is manufactured for use with the type of gas indicted on the nameplate.

Contact the factory if your type of gas does not match the nameplate data.

All gas connectors must be in accordance with local codes and comply with the National Fuel Federal Gas Codes ANSI Z223.1 latest edition.

This appliance should be installed with a separate gas valve in the gas line ahead of the unit. Use a 3/4 inch or larger gas supply line.

Remove the 5/16 inch nuts securing the rear of burners. These nuts are for securing the main burners during transportation only. The rear burner shield must be removed to gain access to the nuts.

A pressure regulator for the type of gas specified is installed on each appliance.

This regulator must be installed in the gas supply line. (Note the direction of the gas flow arrow.)

The pressure in the manifold of the appliance should be tested with a manometer and the regulator adjusted for proper pressure with the appliance operating at full fire. A 1/8 inch NPT tap is provided in the manifold for connecting a manometer.

Correct manifold pressures are:

5 inches water column for natural gas

10 inches water column for propane

When replacing the plug in the manifold, a pipe joint compound or sealant should be used that is resistant to the action of liquid petroleum gas.

Initial adjustments are the responsibility of the installer and are not chargeable to Lang Manufacturing International.

After the griddle is in its final position, adjust the legs to create 1/8 inch slant from back to front.

This will allow the grease to run into the grease gutter and provide the proper combustion air for the burners.

DANGER: THIS APPLIANCE MUST BE GROUNDED AT THE TERMINAL PROVIDED. FAILURE TO GROUND THE APPLIANCE COULD RESULT IN ELECTROCUTION AND DEATH.



WARNING

INSTALLATION OF THE UNIT MUST BE DONE BY PERSONNEL QUALIFIED TO WORK WITH ELECTRICITY AND PLUMBING. IMPROPER INSTALLATION CAN CAUSE INJURY TO PERSONNEL AND/OR DAMAGE TO EQUIPMENT. UNIT MUST BE INSTALLED IN ACCORDANCE WITH ALL APPLICABLE CODES.

NOTICE: The data plate is located on the right side of the griddle. The griddle voltage, serial number, gas specifications, and clearance specifications are on the data plate. This information should be carefully read and understood before proceeding with the installation.

NOTICE: The installation of any components such as a vent hood, grease extractors, fire extinguisher systems, must conform to their applicable National, State and locally recognized installation standards.

INITIAL START UP

Initial Lighting Procedure

Clean the preservative coating from the griddle plate and splash guard. Add a mild detergent to hot water and wash the griddle plate and splash guard. Rinse with a damp sponge and dry with a clean rag.

WARNING: BEFORE LIGHTING, USE A SOAP AND WATER SOLUTION TO TEST ALL JOINTS FOR GAS LEAKS.

- Plug the unit into a 115-volt power supply.
- Turn the ON-STANDBY toggle switch to ON.
- Set the temperature dials to the desired temperature.
- To turn the griddle off, simply turn the main toggle switch to STANDBY.

Seasoning the Griddle Plate (non chrome only)

- Set the temperature dials to 300°F (148°C).
- Observe the burners through the opening at the top of the control panel.
- When the burners go OFF, apply a thin coat of high-grade, non-salted vegetable oil to the griddle surface.
- Rub the oil into the griddle surface with the flat side of a spatula or a towel.
- Recoat any dry spots that appear then wait two minutes and wipe off any excess oil.
- Repeat the seasoning process at 350°F (176°C) and at 400°F (204°C).

NOTICE: During the first few hours of operation you may notice a small amount of smoke coming off the griddle, and a faint odor from the smoke. This is normal for a new griddle and will disappear after the first few hours of use.

OPERATION

Setting the Griddle Temperature

The suggested time and temperature chart (below) is provided as a guide for the products listed only. If different temperature settings are to be used, select one side of the griddle and operate at the lowest temperature. Adjoining sections should be set at progressively higher temperatures. Do not try to operate the end sections hot and the center sections cool.



ALWAYS KEEP THE AREA NEAR THE APPLIANCE FREE FROM COMBUSTIBLE MATERIALS.

KEEP FLOOR IN FRONT OF EQUIPMENT CLEAN AND DRY. IF SPILLS OCCUR, CLEAN IMMEDIATELY, TO AVOID THE DANGER OF SLIPS OR FALLS.

SUGGESTED TIMES AND TEMPERATURES		
PRODUCTS	TEMPERATURE (F / C)	TIME (MIN)
HAMBURGER	350°F (176°C)	
2 patties per LB		6 to 8
4 patties per LB		4 to 6
6 patties per LB		3 to 4
STEAKS		
1/2 to 3/4 inch thick, cooked medium	375°F (190°C)	5 to 7
3/4 to 1 inch thick, cooked medium		8 to 10
Lamb Chops	350°F (176°C)	6 to 8
Pork Chops		6 to 8
Salmon		6 to 8
Halibut	325°F (162°C)	6 to 8
Snapper		6 to 8
Hashbrown Potatoes	375°F (190°C)	3 to 4
Bacon	350°F (176°C)	3 to 4
Sausage Links or Patties		3 to 4
Ham (Pre-cooked)	375°F (190°C)	2
Eggs	275°F (135°C)	2 to 4
Note: The times and temperatures in this chart are intended as a general guide and starting point. Your actual times and temperatures may vary from this chart.		

OPERATION

Loading the Griddle

An understanding of how the griddle sections are controlled will be a valuable aid in loading your griddle.

Each 12 inch section of your griddle is independently controlled. The temperature control sensor is mounted under the griddle plate in the center of each cooking section.

If the product is loaded directly over the temperature sensor, that section will turn on and the burner will heat the entire cooking section. If the product is loaded to the side, front or back of the temperature sensor, the thermostat will react to the temperature change much slowly.

During slow periods with minimal loads, do not load directly over the thermostat sensors as this will unnecessarily turn the burners on and overheat the remainder of the section not being utilized.

Turn the product and continue cooking until it has reached its desired degree of doneness.

Remove the product from the griddle.

When reloading the griddle, first use the griddle surface on which a previous load was not placed. This will insure you the proper griddle temperature.

SEQUENCE OF OPERATION

Power On

When the griddle is connected to 115 Volt power, and the switch is turned "ON" the spark module for each section starts sparking.

When the individual pilot tubes ignite, and the pilot flame is verified, the spark module will stop sparking. Note: The pilot tubes will remain lit until the griddle is turned "OFF" or the gas is shut off.

The operator can now set the temperature of that section by selecting it on the temperature dial.

When the temperature on the dial is set higher than the temperature of the griddle section the thermostat will generate a "Heat Call". If the pilot tube is lit, the call goes to the control opening the valve. The pilot burner ignites the main burner.

As the griddle section temperature increases the thermostat turn off the heat call, followed by the close of the gas valve.

When the griddle temperature drops below the set temperature the thermostat generates a new heat call and the sequence repeats.

MAINTENANCE & CLEANING

Daily Cleaning (Non chrome only)

- Empty the grease drawer daily or whenever it is 3/4 full. Clean using mild soap and warm water.
- Keep the griddle surface clean. After each cooking load, scrape the griddle surface to remove any carbonized grease.
- Once a day or when necessary the non chrome griddle surface should be thoroughly cleaned and seasoned again. Use a griddle stone, griddle pad, or liquid cleaner. Rub with the grain of the metal, being careful not to scrape the splash guard.
- Following the scraping, a damp cloth and non-silicated, non-abrasive, non-chlorinated cleaner such as Bon-Ami may be used to wipe surface clean, followed by wiping with a clean wet cloth.

Weekly Cleaning (Non chrome only)

- A mild detergent with water or one of the many commercial cleaners may be used.
- Be sure to rinse thoroughly and coat the griddle with a thin film of oil to prevent rusting, non-chrome surfaces only.
- Clean the exterior of the appliance with hot water and a mild detergent to maintain a gleaming appearance.
- Re-season the griddle plate after each cleaning, non-chrome surfaces only.

Burner Air Shutter Adjustment

- The air shutters are pre-set at the factory. However, minor adjustments may be required in the field to accommodate differences in gas and elevation.
- To adjust the air shutters, loosen the set screw holding the air damper to the burner near the gas inlet.
- Adjust the air mixture until the burner flame just flickers on the burner. "Lift-off" or yellow flame indicates improper shutter adjustment.
- Periodically inspect and clean the air shutters to insure complete combustion.

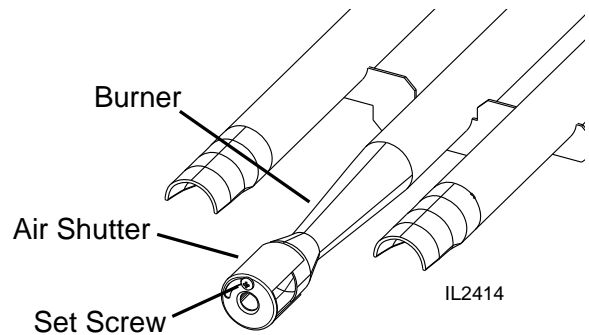

Griddle Care (Chromium Surfaces)

It takes very little time and effort to keep this Industrial Chromium griddle surface sparkling clean and performing at top efficiency. DO NOT allow grease to accumulate as it will carbonize and become difficult to remove. To prevent this condition the following cleaning suggestions should be followed:

1. Remove excess grease and food regularly with a 4" (100mm) wide Razor Sharp type scraper and wipe surface with a damp cloth if desired.
2. Following the scraping, for end of the day cleaning, a damp cloth and a non-silicated, nonabrasive, non-chlorinated cleaner such as Bon-Ami may be used to wipe surface clean, followed by wiping with a clean wet cloth.
3. Follow steps 2 and 3 from Griddle Care (Non-Chromium Surfaces) above.

CAUTION

1. **Never** use pumice, griddle stones, or abrasives on a chromium surface.
2. **Never** strike a chromium griddle surface with a sharp instrument or spatula edge.
3. **Never** use steel wool.
4. **Never** use commercial liquid grill cleaner on the griddle surface.
5. **Abusing** surface voids the warranty.

CHROME GRIDDLE SURFACE LIMITED WARRANTY EXCLUSIONS

Your Chrome griddle has been designed to give you many years of cooking reliability and requires minimum maintenance to keep the chrome surface in its original condition. All Chrome griddle surfaces are warranted for a period of 5 years against manufacturing defects to the original owner from the date of installation. This limited warranty is void if it is determined by Lang Manufacturing or one of its authorized representatives that the chrome surface has been misused or abused or subjected to the following situations:

1. Improperly installed.
2. Incorrect voltage applied to Chrome units allowing the surface to overheat and discolor.
3. The misuse of any instrument or tool which scratches or makes indentations in the surface which could cause the surface to peel, flake, or chip off.
4. The use of any chemical or abrasive cleaning solution, griddle brick, stone, screen or other cleaning products which could damage and affect the performance of the chrome surface.
5. The neglect of daily routine maintenance to the chromium surface.



KEEP WATER AND SOLUTIONS OUT OF CONTROLS. NEVER SPRAY OR HOSE CONTROL CONSOLE, ELECTRICAL CONNECTIONS, ETC.

MOST CLEANERS ARE HARMFUL TO THE SKIN, EYES, MUCOUS MEMBRANES AND CLOTHING. PRECAUTIONS SHOULD BE TAKEN TO WEAR RUBBER GLOVES, GOGGLES OR FACE SHIELD AND PROTECTIVE CLOTHING. CAREFULLY READ THE WARNING AND FOLLOW THE DIRECTIONS ON THE LABEL OF THE CLEANER TO BE USED.

NOTICE: Never leave a chlorine sanitizer in contact with stainless steel surfaces longer than 10 minutes. Longer contact can cause corrosion.

Calibration

- Set the temperature dials to 350°F (176°C)
- Allow the burners to cycle ON and OFF at least five times before attempting to calibrate
- Place a surface thermometer in the center of each cooking section to be calibrated.
- Allow the burners to cycle several times while recording the temperature at which the burners turn ON and OFF.
- Average the temperatures together, if the average temperature is within 10° of the set temperature, the thermostat is within specifications and needs no adjustment.
- If the thermostat is out of specification, remove the thermostat knob and inset a small flat blade screw driver down the stem of the thermostat and turn the adjusting screw at the base of the stem.
- Turning the screw counter-clockwise raises the griddle temperature while clockwise lowers the temperature.

TROUBLESHOOTING

Symptoms

The chart below is to assist in the troubleshooting of the griddle.

Refer to the Symptoms column to locate the type of failure then to the Possible Cause for the items to be checked.

Lang Envirozone Thermostat Gas Griddle Troubleshooting		
Symptom	Possible Cause	Test
No sections spark	Griddle not plugged in	Check power cord connection
	Switch power not connected	Check connection of switch on the front panel
	No power at plug	Verify plug has power
One or more sections do not spark	Main connector on pilot ignition control not plugged in properly	Check all connections on pilot ignition control
	Spark wire not connected to pilot ignition controller or ignitor	Check spark wire (orange wire) connections
	Pilot ignition control failed	Replace pilot ignition control
Ignitor sparks, but does not light pilot tube	No gas to griddle	Check gas connection and shut off valve
	Gas supply not purged of air	Try ignition sequence again
	No gas to pilot tube	Check that pilot valve(s) are opened. Turn screw on valve counter-clockwise Check voltage across pilot solenoid valve, should be 120V
	Ignitor is sparking away from electrode	Check that ignitor is sparking across the electrodes
Pilot tube is lit, but burner will not light	All pilot tube ports are not lit	Check that all ports on pilot tube are lit
	Thermostat failed	Turn thermostat to max temp and check resistance across thermostat
	Gas valve failed	Apply 120V to valve and listen for solenoid actuation
Ignitor continues to spark after pilot tube is lit	Electrode not sensing pilot flame because flame is too small	Adjust pilot flame by opening pilot valve. Turn screw on valve counter-clockwise
Yellow or orange in pilot flame	Primary air hole covered	Check air hole in pilot tube near inlet elbow for any obstruction
	Pilot flame too large	Adjust pilot flame by closing pilot valve. Turn screw on valve clockwise

NOTICE: Service on this, or any other, LANG appliance must be performed by qualified personnel only. Consult your LANG authorized service agent directory or call technical service at (314) 678-6315, or www.langworld.com For the service agent nearest you.



120 VOLTAGES IS PRESENT INSIDE THIS APPLIANCE WHEN THE UNIT IS PLUGGED/WIRED INTO A LIVE RECEPTACLE. BEFORE REPLACING ANY PARTS, DISCONNECT THE UNIT FROM THE ELECTRIC POWER SUPPLY.



USE OF ANY REPLACEMENT PARTS OTHER THAN THOSE SUPPLIED BY LANG OR THEIR AUTHORIZED DISTRIBUTORS CAN CAUSE BODILY INJURY TO THE OPERATOR AND DAMAGE TO THE EQUIPMENT AND WILL VOID ALL WARRANTIES.



MATERIAL	N/A	MODEL NO.	PART NO.	
FINISH		TITLE	2M-61122-W53	
DR: DJS	CK:	DATE: 11/28/2011	WIRE DIAGRAM - 272ZT (NO TIMERS)	
TOLERANCE: UNLESS NOTED: .XXX ± .015	REVISIONS	REV.	DATE/ECO	DESCRIPTION OF CHANGE
ANGLES: 1°				DR

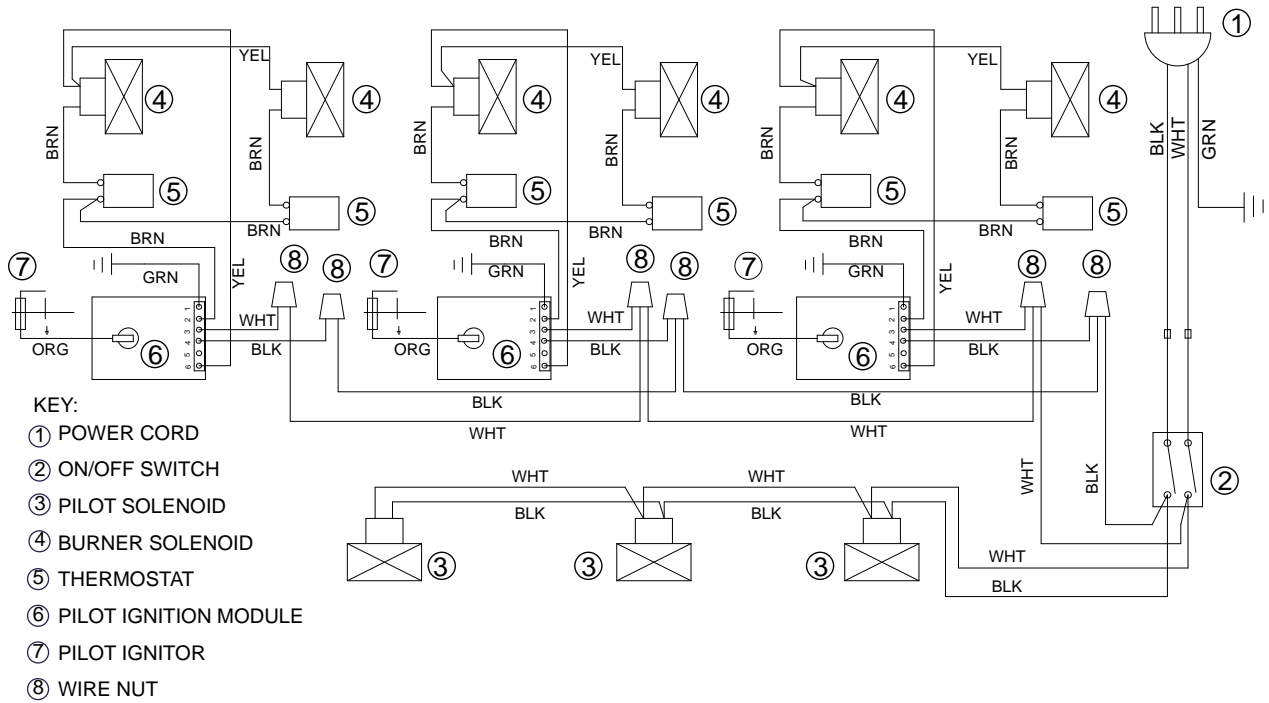

MATERIAL		MODEL NO.	PART NO.	
FINISH		TITLE	61122-W55-1	
DR: TDV	CK:	DATE: 8-7-13	WD 2382T 36" GAS GRIDDLE WITH CSG24 CLAMSHELL, 120V VALVES	
TOLERANCE: UNLESS NOTED: .XXX ± .015	REVISIONS	REV.	DATE/ECO	DESCRIPTION OF CHANGE
ANGLES: 1°		A	9-5-13 ECD 13168	ADDED RELAY AND WIRING CHANGE
				TDV

- GRIDDLE**
- KEY:**
- ① POWER CORD
 - ② ON/OFF SWITCH
 - ③ PILOT SOLENOID
 - ④ BURNER SOLENOID
 - ⑤ THERMOSTAT
 - ⑥ PILOT IGNITION MODULE
 - ⑦ PILOT IGNITOR
 - ⑧ WIRE NUT

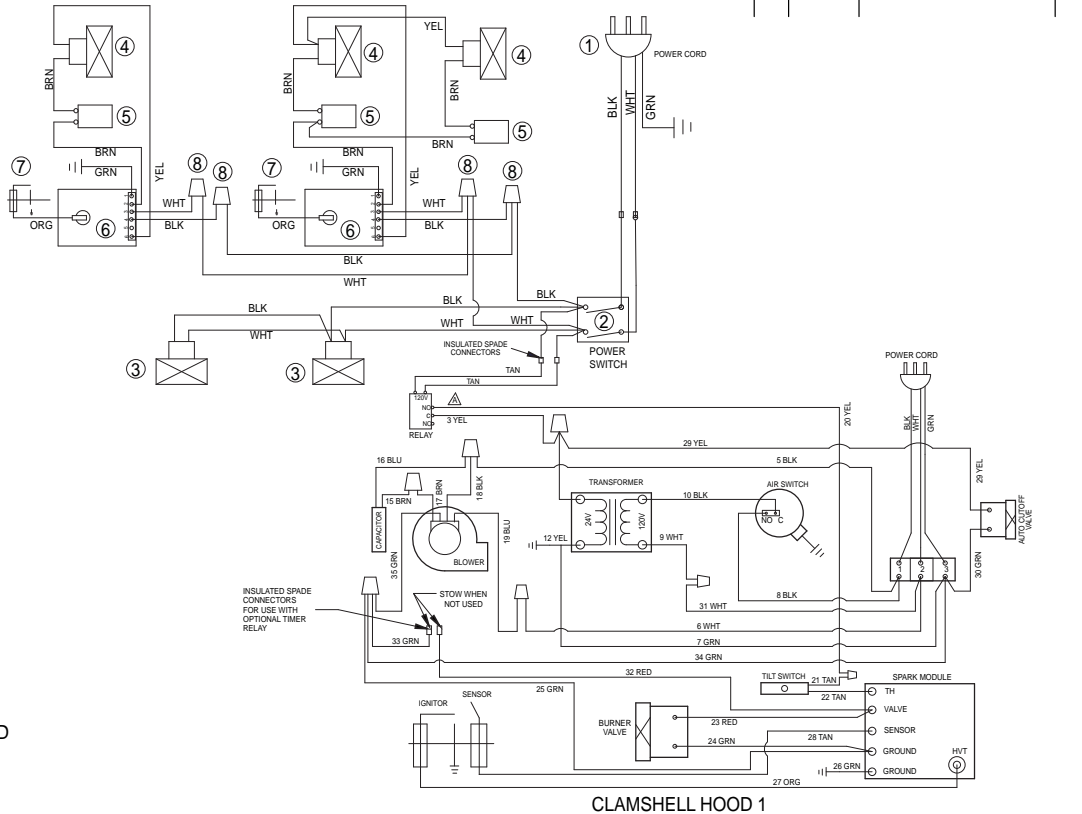

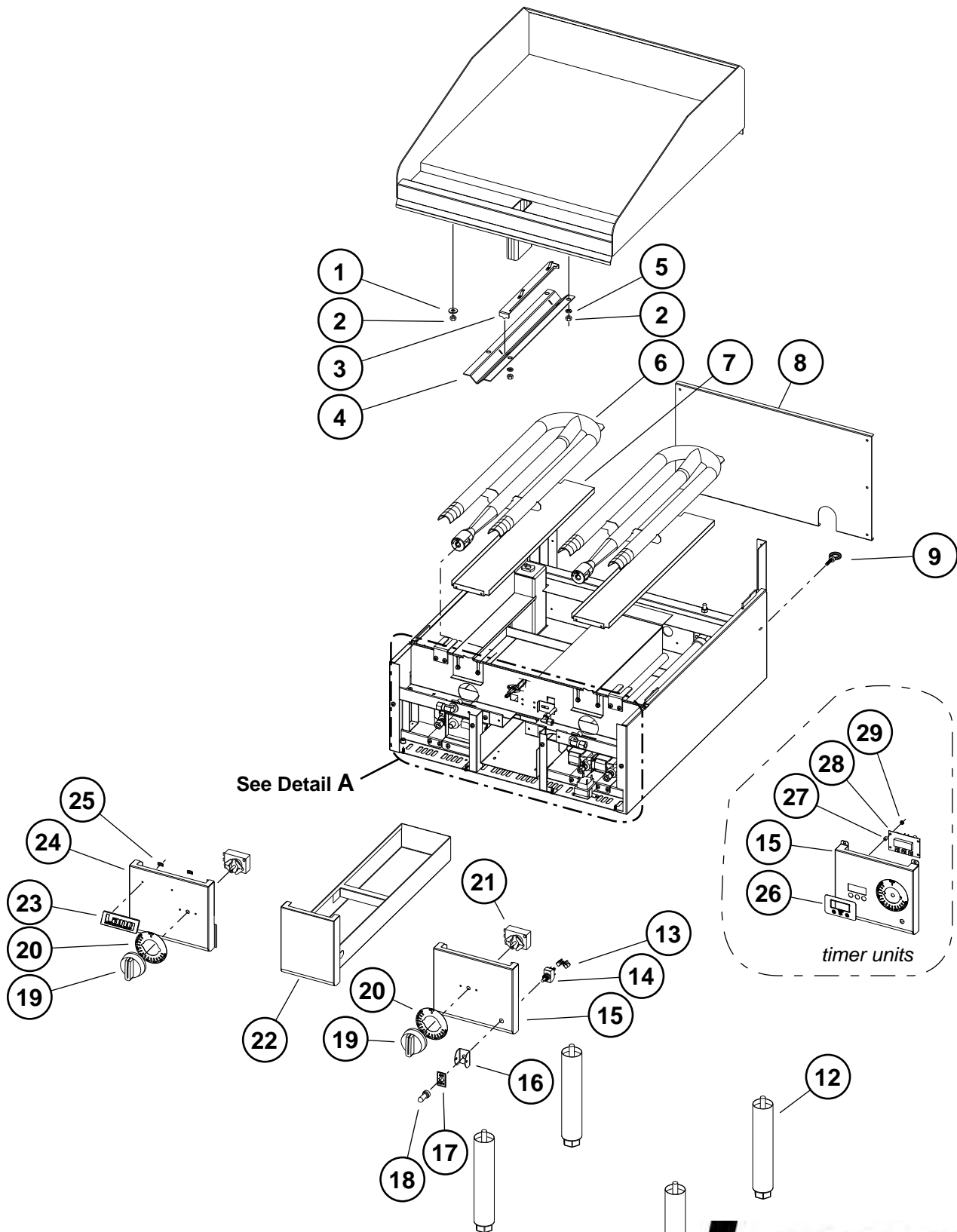

**MODEL:ENVIROZONE THERMOSTAT
GAS GRIDDLE**

Lang[®]

SK2564, Rev. A 5/17/2014

2M-Z1785; ENVIROZONE-TSTAT GAS GRIDDLE

PARTS LIST

April 23, 2015, Rev. C

Model: 224ZT, 236ZT, 248ZT, 260ZT, 272ZT GAS GRIDDLE				
Fig No	Part Number	Quantity	Description	Application
1	2C-20201-06	2	WSHR PLT 5/16 FLAT USS	ALL
2	2C-20301-06	10	NUT HEX 5/16-18 PLTD	224ZT
		14		236ZT
		18		248ZT
		22		260ZT
		26		272ZT
3	K9-Z4793-W1	2	BULB CLAMP - EZONE	224ZT
		3		236ZT
		4		248ZT
		5		260ZT
		6		272ZT
4	K9-Z4794-W1	2	BULB HOLDER - EZONE	224ZT
		3		236ZT
		4		248ZT
		5		260ZT
		6		272ZT
5	2C-20202-08	8	WSHR PLT 5/16 LOCK SPLIT	224ZT
		12		236ZT
		16		248ZT
		20		260ZT
		24		272ZT
6	K9-141-171-W2	2	GRIDDLE BURNER ASSY	224ZT
		3		236ZT
		4		248ZT
		5		260ZT
		6		272ZT
	K9-141-171-3W2	2	GRIDDLE BURNER ASSY-30" DEEP	224ZTD
		3		236ZTD
		4		248ZTD
		5		260ZTD
		6		272ZTD
7	K9-141-181	2	BAFFLE UNDER BURNER	224ZT
		3		236ZT
		4		248ZT
		5		260ZT
		6		272ZT
	K9-141-182	1	BAFFLE BETWEEN BURNERS	248ZT
		2		260ZT
		3		272ZT
8	K9-EZG-382-W04	1	FLUE 1' - GRIDDLE W/CSG24	260ZTHG
	K9-EZG-382-W8		FLUE BRACKET-GRID W/CSG24	
	K9-141-271-2		FLUE 2'	224ZT
	K9-141-271-3		FLUE 3'	236ZT
	K9-141-271-4		FLUE 4'	248ZT
	K9-141-271-5		FLUE 5'	260ZT
	K9-141-271-6		FLUE 6'	272ZT
K9-141-271-W8	FLUE 2' - EZN GRID W/CSE12	224ZTCHG, 224ZTCHE		
9	2C-20119-01	1	EYEBLTFORGD/SHLDR1/4-20X1	ALL
10	K9-141-122-W3	1	RIGHT SIDE	ALL

2M-Z1785; ENVIROZONE-TSTAT GAS GRIDDLE

**IMPORTANT: WHEN ORDERING, SPECIFY VOLTAGE OR TYPE GAS DESIRED
INCLUDE MODEL AND SERIAL NUMBER**

PAGE 1
OF 2

Some items are included for illustrative purposes only and in certain instances may not be available.

PARTS LIST

April 23, 2015, Rev. C

Model: 224ZT, 236ZT, 248ZT, 260ZT, 272ZT GAS GRIDDLE				
11	K9-141-107-1	1	LEFT SIDE STD	ALL
12	2A-72500-20	4	LEG 10.25 WITH ADJ HEX	ALL
13	2C-31007-01	2	TERM DOUBLER FEMALE	ALL
14	2E-Z12020	1	SWITCH-TOGGLE 2P ST	ALL
15	K9-141-231-2-W2	1	FRONT PANEL-RIGHT WELDMNT	224ZT
	K9-141-231-2-W3		FRONT PANEL-ASSY RIGHT w/TIMER	248ZTC-TNAT
	K9-141-231-5-W2		CONTROL PANEL ASSY-5' MID	260ZT
	K9-141-231-6-W3		CNTRL PANEL-MIDDLE ASY 6'	272ZT
	K9-141-236-W13		CONTROL PANEL - 4' & 6"	248ZT, 272ZT
	K9-141-236-W14		FRONT PANEL - LEFT 6'	272ZT
	K9-141-236-W15		FRONT PANEL - RIGHT 6"	236ZT
	K9-141-236-W18		FRONT PANEL - 5' MIDDLE	260ZT
16	Z1-70-07-0343	1	SWITCH GUARD	ALL
17	2M-12-07-0038	1	LABEL ON & OFF	ALL
18	2I-05-07-0013	1	BOOT SWITCH	ALL
19	2R-W498-2	2	KNOB-RED METAL-INSERT.188	224ZT
		3		236ZT
		4		248ZT
		5		260ZT
		6		272ZT
20	2M-W728-W4	2	LABEL - CONTROL 200-550F	224ZT
		3		236ZT
		4		248ZT
		5		260ZT
		6		272ZT
21	2T-30402-07	2	STAT ADJ 550o 48 C/T	224ZT
		3		236ZT
		4		248ZT
		5		260ZT
		6		272ZT
22	K9-50303-18	1	GRS BCKET ASSY, 141 FRT GTR	224ZT, 236ZT
		2		248ZT, 260ZT, 272ZT
	K9-142-251	1	GREASE BUCKET ASSY	224ZTD, 236ZTD
		2		248ZTD, 260ZTD, 272ZTD
23	2M-60301-43	1	DIE CAST PLT LANG SATIN	ALL
24	K9-141-241-W9	1	FRONT PANEL-LEFT END 2FT	224ZT, 236ZT, 248ZT, 260ZT
	K9-141-241-W8		FRONT PANEL-LEFT END 6"	272ZT
	K9-141-241-W10		FRONT PANEL-LEFT w/TIMER	248ZTC-TNAT
25	2C-20602-04	2	TINNERMAN SPD NUT 1/8 DIA	ALL
26	2M-W1762	2	LABEL TIMER	TIMER UNITS
27	2A-20504-12	8	SPACER - NYLON .312OD x .25	TIMER UNITS
28	2J-40102-71	2	TIMER	TIMER UNITS
29	2C-20301-11	8	NUT HEX 8-32 PLTD	TIMER UNITS
NI	2E-31107-02-W2	1	CORDSET 14/3 15A 120V 10'	ALL
NI	2M-61122-W54	AR	WIRE DIAGRAM - 224ZT	ALL
NI	2P-50100-15	1	GRIDDLE SCRAPER 12"	CROME UNITS
NI	2P-50100-15-1	-	RE-FILL REPLACEMENTS	CROME UNITS
NI	2P-50100-16	1	BOM AMI CLEANER	CROME UNITS
NI	2P-50100-17	1	20" PALMYRA BRUSH	CROME UNITS

2M-Z1785; ENVIROZONE-TSTAT GAS GRIDDLE

**IMPORTANT: WHEN ORDERING, SPECIFY VOLTAGE OR TYPE GAS DESIRED
INCLUDE MODEL AND SERIAL NUMBER**

PAGE 2
OF 2

Some items are included for illustrative purposes only and in certain instances may not be available.



2M-Z1785; ENVIROZONE-TSTAT GAS GRIDDLE

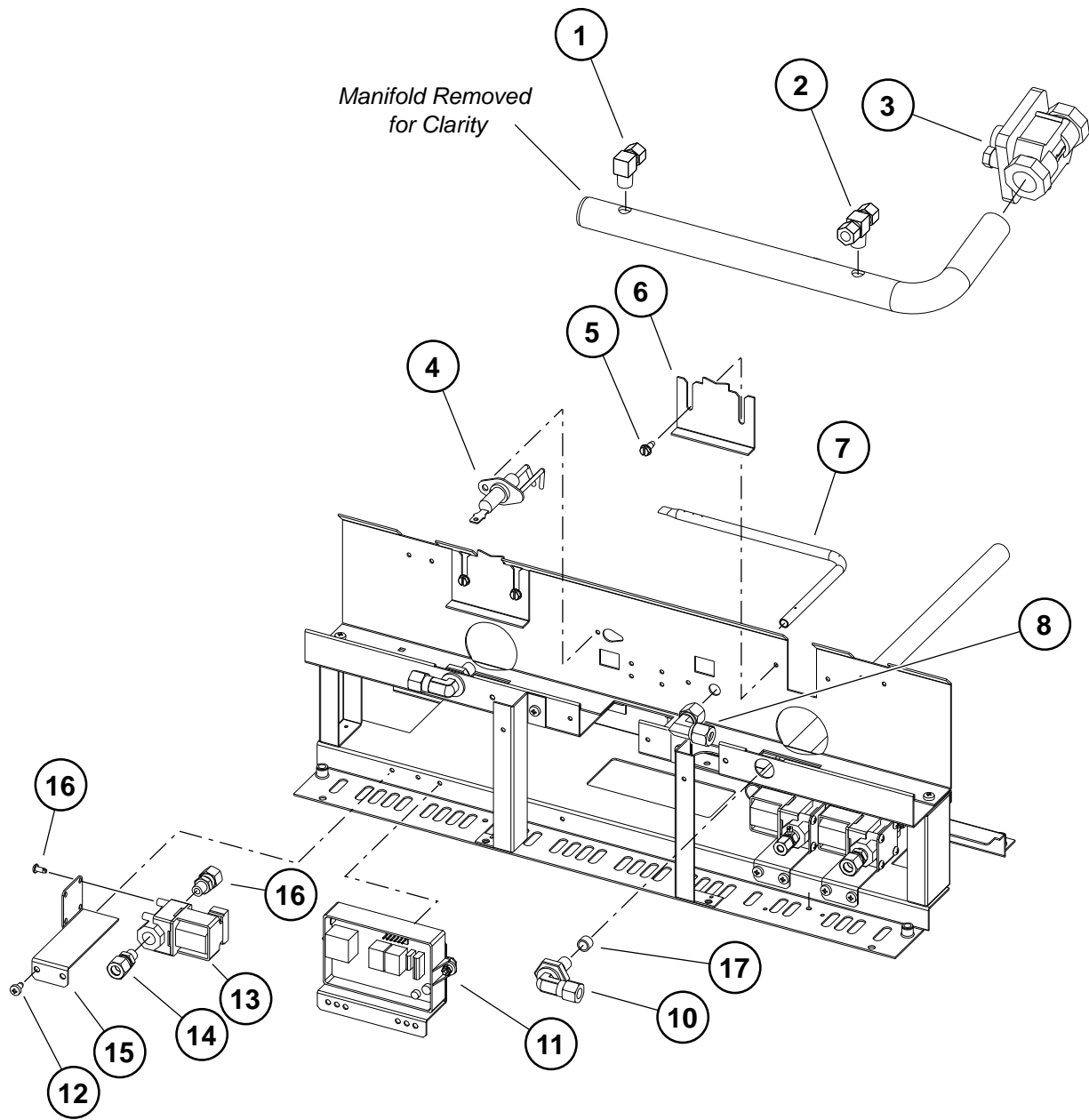

DETAIL A

Lang[®]

SK2565, Rev. A 4/23/2015

PARTS LIST

April 23, 2015, Rev. C

Model: 224ZT, 236ZT, 248ZT, 260ZT, 272ZT DETAIL A				
Fig No	Part Number	Quantity	Description	Application
1	2K-70101-03	1	BRASTBEELBOW 1/4NPT-3/8CC	224ZT, 236ZT
		2		248ZT, 260ZT
		3		272ZT
2	2K-70101-06	1	BRASTEE BRNCH 1/4NPTM-3/8	224ZT
		2		236ZT, 248ZT
		3		260ZT, 272ZT
3	2V-80501-04	1	GAS REG 3/4X3/4 CLS I	NAT
	2V-80501-05		GAS REG 3/4X3/4 CLS II	LP
4	2J-80302-W1	1	IGNITOR ELECTRODE	224ZT
		2		236ZT, 248ZT
		3		260ZT, 272ZT
5	2C-Z5883	10	10-24 X 1/2 FZA SCREW	224ZT
		18		236ZT
		20		248ZT
		28		260ZT
		30		272ZT
6	K9-141-146	2	PROBE GUARD SUPPORT	224ZT
		3		236ZT
		4		248ZT
		5		260ZT
		6		272ZT
7	2F-80002-W19	1	TUBE - LIGHTER .25 DIA	224ZT
		2		236ZT, 248ZT
		3		260ZT, 272ZT
8	2K-70101-51	1	BRASTBE ELBOW 1/4CCX1/4CC	224ZT
		2		236ZT, 248ZT
		3		260ZT, 272ZT
10	2A-W1185	2	ORIFICE FITTING - 90 DEG	224ZT
		3		236ZT
		4		248ZT
		5		260ZT
		6		272ZT
11	PS-60101-W16	1	KIT,IGN MOD REPLACMENT Z MODELS	224ZT
		2		236ZT, 248ZT
		3		260ZT, 272ZT
11a	2J-80300-W20-1	AR	PILOT IGNITION MODULE	ALL
12	2C-20102-12	22	SCRW PHD ST 10-32X3/8	224ZT
		29		236ZT
		38		248ZT
		44		260ZT
		48		272ZT

2M-Z1785; ENVIROZONE-TSTAT GAS GRIDDLE

**IMPORTANT: WHEN ORDERING, SPECIFY VOLTAGE OR TYPE GAS DESIRED
INCLUDE MODEL AND SERIAL NUMBER**

PAGE 1
OF 3

Some items are included for illustrative purposes only and in certain instances may not be available.



PARTS LIST

April 23, 2015, Rev. C

Model: 224ZT, 236ZT, 248ZT, 260ZT, 272ZT DETAIL A				
Fig No	Part Number	Quantity	Description	Application
13	2V-80502-W07	3	VALVE SOLENOID-1/8 NPT	224ZT
		5		236ZT
		6		248ZT
		8		260ZT
		9		272ZT
14	2K-45300	5	FITTING 3/8CC X 1/8NPT	224ZT
		8		236ZT
		10		248ZT
		13		260ZT
		15		272ZT
15	K9-141-156-W4	2	VALVE BRACKET-RIGHT	248ZT, 260ZT
		3		272ZT
	K9-141-156-W5	1	VALVE BRACKET LEFT	224ZT
		2		236ZT, 248ZT, 260ZT
	K9-141-156-W6	2	VALVE BRACKET-SHORT RIGHT	224ZT
		3		236ZT
		4		260ZT
		6		272ZT
16	2C-20102-08	12	SCRW PHD ST 8-32X.375	224ZT
		20		236ZT
		24		248ZT
		32		260ZT
		36		272ZT
17	2A-45408	2	ORIFICE HOOD .0935 #42	224ZT-NAT
		3		236ZT-NAT
		4		248ZT-NAT
		5		260ZT-NAT
		6		272ZT-NAT
		2		224ZT-LP
	2A-80400-12	3	ORIFICE HOOD .0595 #53	236ZT-LP
		4		248ZT-LP
		5		260ZT-LP
		6		272ZT-LP
		2		224ZTD-NAT
		Y9-80400-18		3
	4		248ZTD-NAT	
	5		260ZTD-NAT	
	6		272ZTD-NAT	
	2		224ZTD-LP	
	Y9-80400-13		3	ORIFICE HOOD .0892 #43
		4	248ZTD-LP	
5		260ZTD-LP		
6		272ZTD-LP		

2M-Z1785; ENVIROZONE-TSTAT GAS GRIDDLE

**IMPORTANT: WHEN ORDERING, SPECIFY VOLTAGE OR TYPE GAS DESIRED
INCLUDE MODEL AND SERIAL NUMBER**

PAGE 2
OF 3

Some items are included for illustrative purposes only and in certain instances may not be available.



PARTS LIST

April 23, 2015, Rev. C

Model: 224ZT, 236ZT, 248ZT, 260ZT, 272ZT DETAIL A				
Fig No	Part Number	Quantity	Description	Application
ni	2K-70104-03	1	FLEXIBLE TUBE 3/8OD X 8	224ZT
		3		236ZT
		4		248ZT, 260ZT
		6		272ZT
ni	2K-70104-04	1	FLEXIBLE TUBE 3/8OD X 12	224ZT
ni	2K-Z4921	3	BURNER TUBE FLEX 3/8 OD	224ZT
		5		236ZT
		6		248ZT
		8		260ZT
		9		272ZT
ni	2K-Z6943	1	GAS LINE 1/4"D x 8"L	224ZT
		2		236ZT, 248ZT
		3		260ZT, 272ZT
ni	K9-141-705	1	IGNITION WIRE	224ZT
		2		236ZT, 248ZT
		3		260ZT, 272ZT

STAR INTERNATIONAL HOLDINGS INC.
 Star - Lang - Wells - Toastmaster
 265 Hobson Street - Smithville, Tennessee U.S.A.
 (314) 678-6303
www.langworld.com