

Lang



Installation, Operation, Maintenance, & Troubleshooting

Model: CLB-2L-L Electric Cruise Line Double Broiler

Serial:

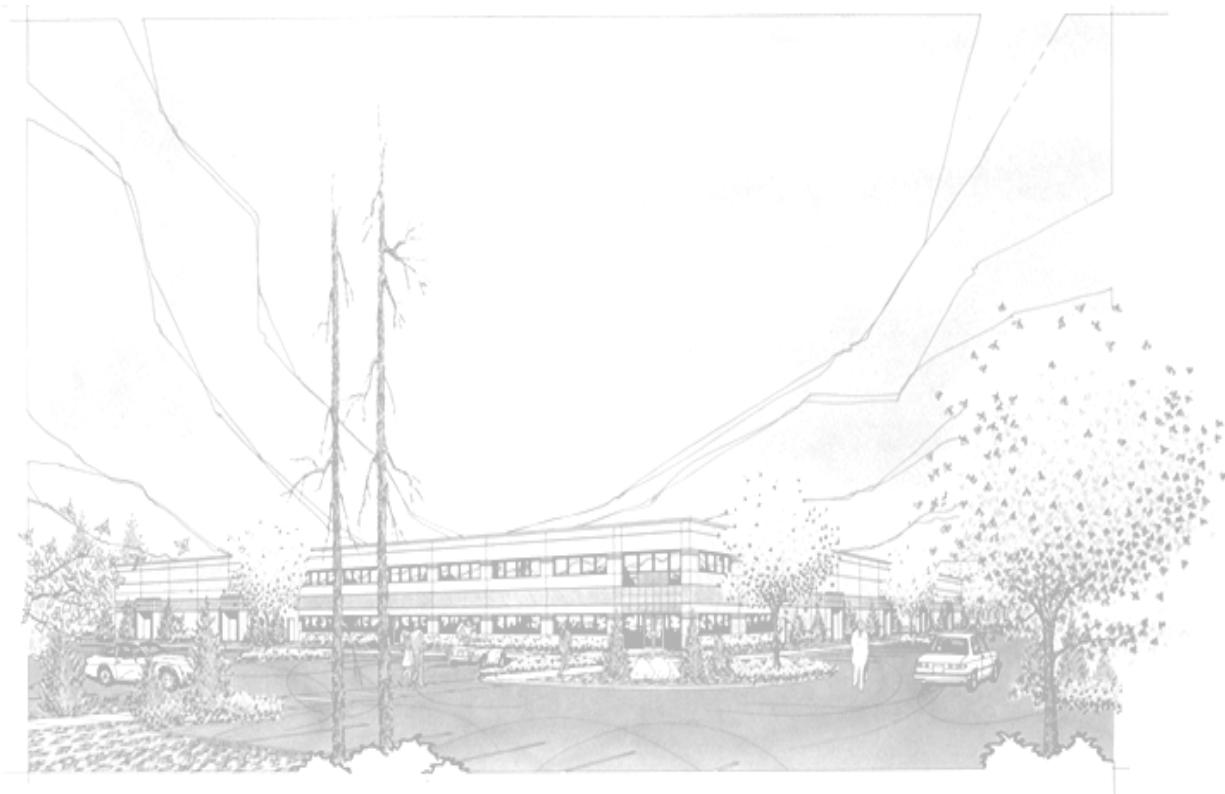





THIS MANUAL MUST BE RETAINED FOR FUTURE REFERENCE. READ, UNDERSTAND AND FOLLOW THE INSTRUCTIONS AND WARNINGS CONTAINED IN THIS MANUAL.

FOR YOUR SAFETY

DO NOT STORE OR USE GASOLINE OR OTHER FLAMMABLE VAPORS AND LIQUIDS IN THE VICINITY OF THIS OR ANY OTHER APPLIANCE.

WARNING: IMPROPER INSTALLATION, ADJUSTMENT, ALTERATION, SERVICE OR MAINTENANCE CAN CAUSE PROPERTY DAMAGE, INJURY OR DEATH. READ THE INSTALLATION, OPERATING AND MAINTENANCE INSTRUCTIONS THOROUGHLY BEFORE INSTALLING OR SERVICING THIS EQUIPMENT.

<u>DANGER</u>	POTENTIALLY HAZARDOUS SITUATION WHICH, IF NOT AVOIDED, COULD RESULT IN DEATH.	
<u>WARNING</u>	POTENTIALLY HAZARDOUS SITUATION WHICH, IF NOT AVOIDED, COULD RESULT IN DEATH OR SERIOUS INJURY.	
<u>CAUTION</u>	POTENTIALLY HAZARDOUS SITUATION WHICH, IF NOT AVOIDED, MAY RESULT IN MINOR OR MODERATE INJURY.	
<u>NOTICE</u>	Helpful operation and installation instructions and tips are present.	

NOTICE: THIS EQUIPMENT IS APPROVED FOR INSTALLATION ONLY ON VESSELS GREATER THAN 65 FEET IN LENGTH, IN ACCORDANCE WITH USCG REGULATIONS IN TITLE 46 CFR 110-113. ANY WIRING USED IN THE INSTALLATION OF THIS APPLIANCE MUST BE STRANDED COPPER.

TABLE OF CONTENTS

CHAPTER	PAGE
1. TABLE OF CONTENTS	3
2. READ FIRST	4
3. UNPACKING	6
4. INSTALLATION	7
5. INITIAL START-UP	8
6. OPERATION	8
7. CLEANING & MAINTENANCE PROCEDURES.....	9
8. TROUBLESHOOTING	10
9. PARTS LISTS.....	11
10. EXPLODED VIEW.....	12
11. WIRING DIAGRAMS.....	17

CAUTION:	THE BROILER WEIGHS 850 LBS. (385.56 kg). FOR SAFE HANDLING, INSTALLER SHOULD OBTAIN HELP AS NEEDED, OR EMPLOY APPROPRIATE MATERIALS HANDLING EQUIPMENT (SUCH AS A FORKLIFT, DOLLY, OR PALLET JACK) TO REMOVE THE UNIT FROM THE SKID AND MOVE IT TO THE PLACE OF INSTALLATION.	
CAUTION:	ANY STAND, COUNTER OR OTHER DEVICE ON WHICH BROILER WILL BE LOCATED MUST BE DESIGNED TO SUPPORT THE WEIGHT OF THE BROILER (850 LBS.).	
CAUTION:	SHIPPING STRAPS ARE UNDER TENSION AND CAN SNAP BACK WHEN CUT.	
DANGER:	THIS APPLIANCE MUST BE GROUNDED AT THE TERMINAL PROVIDED. FAILURE TO GROUND THE APPLIANCE COULD RESULT IN ELECTROCUTION AND DEATH.	
<u>WARNING</u>	INSTALLATION OF THE UNIT MUST BE DONE BY PERSONNEL QUALIFIED TO WORK WITH ELECTRICITY. IMPROPER INSTALLATION CAN CAUSE INJURY TO PERSONNEL AND/OR DAMAGE TO EQUIPMENT. UNIT MUST BE INSTALLED IN ACCORDANCE WITH ALL APPLICABLE CODES.	
<u>NOTICE</u>	The data plate is located behind the access cover to the right of the unit. The broiler voltage, wattage, serial number, wire size, and clearance specifications are on the data plate. This information should be carefully read and understood before proceeding with the installation.	
<u>NOTICE</u>	The installation of any components such as a vent hood, grease extractors, fire extinguisher systems, must conform to their applicable National, State and locally recognized installation standards.	
CAUTION:	ALWAYS KEEP THE AREA NEAR THE APPLIANCE FREE FROM COMBUSTIBLE MATERIALS.	
CAUTION:	KEEP FLOOR IN FRONT OF EQUIPMENT CLEAN AND DRY. IF SPILLS OCCUR, CLEAN IMMEDIATELY, TO AVOID THE DANGER OF SLIPS OR FALLS.	
<u>WARNING</u>	KEEP WATER AND SOLUTIONS OUT OF CONTROLS. NEVER SPRAY OR HOSE CONTROL CONSOLE, ELECTRICAL CONNECTIONS, ETC.	
CAUTION:	MOST CLEANERS ARE HARMFUL TO THE SKIN, EYES, MUCOUS MEMBRANES AND CLOTHING. PRECAUTIONS SHOULD BE TAKEN TO WEAR RUBBER GLOVES, GOGGLES OR FACE SHIELD AND PROTECTIVE CLOTHING. CAREFULLY READ THE WARNING AND FOLLOW THE DIRECTIONS ON THE LABEL OF THE CLEANER TO BE USED.	
<u>NOTICE</u>	Service on this, or any other, LANG appliance must be performed by qualified personnel only. Consult your authorized service station directory or call the factory at 1-800-224-LANG (5264), or WWW.LANGWORLD.COM for the service station nearest you.	

IMPORTANT

READ FIRST

IMPORTANT

WARNING

BOTH HIGH AND LOW VOLTAGES ARE PRESENT INSIDE THIS APPLIANCE WHEN THE UNIT IS PLUGGED/WIRED INTO A LIVE RECEPTACLE. BEFORE REPLACING ANY PARTS, DISCONNECT THE UNIT FROM THE ELECTRIC POWER SUPPLY.



CAUTION:

USE OF ANY REPLACEMENT PARTS OTHER THAN THOSE SUPPLIED BY LANG OR THEIR AUTHORIZED DISTRIBUTORS CAN CAUSE BODILY INJURY TO THE OPERATOR AND DAMAGE TO THE EQUIPMENT AND WILL VOID ALL WARRANTIES.



UNPACKING

- CAUTION:** THE BROILER WEIGHS 850 LBS. (385.56 kg). FOR SAFE HANDLING, INSTALLER SHOULD OBTAIN HELP AS NEEDED, OR EMPLOY APPROPRIATE MATERIALS HANDLING EQUIPMENT (SUCH AS A FORKLIFT, DOLLY, OR PALLET JACK) TO REMOVE THE UNIT FROM THE SKID AND MOVE IT TO THE PLACE OF INSTALLATION.
- CAUTION:** ANY STAND, COUNTER OR OTHER DEVICE ON WHICH BROILER WILL BE LOCATED MUST BE DESIGNED TO SUPPORT THE WEIGHT OF THE BROILER (850 LBS.).
- CAUTION:** SHIPPING STRAPS ARE UNDER TENSION AND CAN SNAP BACK WHEN CUT.



3.1 Receiving the Broiler

Upon receipt, check for freight damage, both visible and concealed. Visible damage should be noted on the freight bill at the time of delivery and signed by the carrier's agent. Concealed loss or damage means loss or damage, which does not become apparent until the merchandise has been unpacked. If concealed loss or damage is discovered upon unpacking, make a written request for inspection by the carrier's agent within 15 days of delivery. All packing material should be kept for inspection. Do not return damaged merchandise to Lang Manufacturing Company. File your claim with the carrier.

3.2 Location

Prior to un-crating, move the broiler as near its intended location as practical. The crating will help protect the unit from the physical damage normally associated with moving it through hallways and doorways.

3.3 Un-crating

The broiler is packaged on a pallet, wrapped in plastic to protect from moisture and surrounded by a wooden frame. Remove the wood crating carefully. Improper use of tools can result in damage to the equipment. Remove and discard plastic wrap. Remove and discard desiccant bags placed inside broiler cavity.

The broiler rack frame and rack are secured for shipping purposes and for safety, and should remain secured until unit is at its final location.

Legs, where applicable, are packed inside broiler cavity or cabinet base and should remain there until unit is at the final installation location.

The unit can be safely lifted from bottom with forklift or straps. Use extreme care and follow proper safety procedure regardless of method used and be aware of gravity center, especially with banks of multiple units.

Remove broiler from skid and place in intended location.

INSTALLATION

DANGER: THIS APPLIANCE MUST BE GROUNDED AT THE TERMINAL PROVIDED. FAILURE TO GROUND THE APPLIANCE COULD RESULT IN ELECTROCUTION AND DEATH.



WARNING INSTALLATION OF THE UNIT MUST BE DONE BY PERSONNEL QUALIFIED TO WORK WITH ELECTRICITY. IMPROPER INSTALLATION CAN CAUSE INJURY TO PERSONNEL AND/OR DAMAGE TO EQUIPMENT. UNIT MUST BE INSTALLED IN ACCORDANCE WITH ALL APPLICABLE CODES.



NOTICE The data plate is located behind the access cover to the right of the unit. The broiler voltage, wattage, serial number, wire size, and clearance specifications are on the data plate. This information should be carefully read and understood before proceeding with the installation.



NOTICE The installation of any components such as a vent hood, grease extractors, fire extinguisher systems, must conform to their applicable National, State and locally recognized installation standards.



4.1 Electrical Connection

The electrical connection must be made in accordance with local codes or in the absence of local codes with NFPA No. 70 latest edition (in Canada use: CAS STD. C22.1).

Supply wire size must be large enough to carry the amperage load for the appliance being installed. Wire size information can be found on the data plate.

4.2 Broiler Voltage

The Lang Model CLB-2L-L can be operated on 400 Volts.

INITIAL START UP

5.1 PRE-POWER ON

Initial Start-up

Before the initial use of the broiler, the unit must be wiped down thoroughly with a dry rag, to remove any oils used in manufacturing. Also the unit must be thoroughly allowed to dry itself out. This is done by setting the thermostat to 350°. Allow the range oven to heat until all vapor and condensation has been eliminated. For best results allow the oven to thoroughly dry out. Allow 8 to 12 hours for this process. Note: There may be a small amount of smoke from the unit for the first couple of hours of use, this is normal.

OPERATION

CAUTION: ALWAYS KEEP THE AREA NEAR THE APPLIANCE FREE FROM COMBUSTIBLE MATERIALS.

CAUTION: KEEP FLOOR IN FRONT OF EQUIPMENT CLEAN AND DRY. IF SPILLS OCCUR, CLEAN IMMEDIATELY, TO AVOID THE DANGER OF SLIPS OR FALLS.



6.1 Broiler Controls

The controls are located on the right side of the unit. There are two switches. One on top and one on bottom. The top one controls the front half of the broiler, while the bottom one controls the rear half. There are three positions on each switch: Low, Off, & High.

The broiler rack is adjustable. There are three rack positions available. To set the position, put the product on the rack, push the lever down and forward into one of the positions.

WARNING KEEP WATER AND SOLUTIONS OUT OF CONTROLS. NEVER SPRAY OR HOSE CONTROL CONSOLE, ELECTRICAL CONNECTIONS, ETC.

CAUTION: MOST CLEANERS ARE HARMFUL TO THE SKIN, EYES, MUCOUS MEMBRANES AND CLOTHING. PRECAUTIONS SHOULD BE TAKEN TO WEAR RUBBER GLOVES, GOGGLES OR FACE SHIELD AND PROTECTIVE CLOTHING. CAREFULLY READ THE WARNING AND FOLLOW THE DIRECTIONS ON THE LABEL OF THE CLEANER TO BE USED.



7.1 After each Meal Cleaning

Empty crumb tray daily or when 1/3 full. It is easily removed for washing. Clean exterior of the broiler with hot water and a mild detergent to maintain a gleaming appearance.

7.2 Daily Cleaning

The broiler should be thoroughly cleaned at least once a week in addition to the normal daily cleaning to insure against the accumulation of foreign material. Keep the inside of the broiler and metal deck clean.

9.1 Symptoms

What follows is a chart of Symptoms and Possible Causes to aid in diagnosing faults with the oven.

Refer to the Symptoms column to locate the type of failure then to the Possible Cause for the items to be checked.

To test for a possible cause, refer to the TEST section and locate the Possible Cause then refer to test to identify test procedures.

SYMPTOM	POSSIBLE CAUSE
Broiler will not heat	<ul style="list-style-type: none"> • Failed element • Failed 2 heat switch
Product burning	<ul style="list-style-type: none"> • Product is cooked too long

NOTICE

Service on this, or any other, LANG appliance must be performed by qualified personnel only. Consult your authorized service station directory or call the factory at 1-800-224-LANG (5264), or WWW.LANGWORLD.COM for the service station nearest you.



WARNING

BOTH HIGH AND LOW VOLTAGES ARE PRESENT INSIDE THIS APPLIANCE WHEN THE UNIT IS PLUGGED/WIRED INTO A LIVE RECEPTACLE. BEFORE REPLACING ANY PARTS, DISCONNECT THE UNIT FROM THE ELECTRIC POWER SUPPLY.



9.2 TESTS

If an item on the list is followed by an asterisk (*), the work should be done by a factory authorized service representative.

Possible Cause	TEST
Product is cooked too long	<ul style="list-style-type: none"> • No test available, operational condition
Failed 2 heat switch	<ul style="list-style-type: none"> • Check poles on switch for continuity
Failed element	<ul style="list-style-type: none"> • Remove the wires and check for continuity across the element

CAUTION:

USE OF ANY REPLACEMENT PARTS OTHER THAN THOSE SUPPLIED BY LANG OR THEIR AUTHORIZED DISTRIBUTORS CAN CAUSE BODILY INJURY TO THE OPERATOR AND DAMAGE TO THE EQUIPMENT AND WILL VOID ALL WARRANTIES.



PARTS LIST

CLB-2L-L

Item #	Description	Part Number	Qty
1	Body	N/A	1
2	Pan	CLB-226	2
3	High Temperature Gasket Material	72602-04	132
4	Broiler Switch Panel	CLB-225	2
5	Knob comes with the 2 Heat switch 25 amp	30304-32	4
6	Rack Adjustment	CLB-319	2
7	Screw Stainless Steel 10-32 x 1/2 Hex Head	20111-09	68
8	Front Hood	CLB-212	2
9	1 3/8" Snap Bushing	70801-02	2
10	Terminal Block Mount	CLB-224	1
11	Broiler Heat Shield	CLB-218	3
12	Can Assembly	CLB-001	2
13	Element Holder	CLB-309	6
14	Element	11100-10	8
15	Element Heat Shield	CLB-427	4
16	Large 2 Pole Terminal Block	30500-11	2
17	Nut Hex Stainless Steel 10-24	20303-08	64
18	Washer Stainless Steel 5/16 S.A.E. Flat	20203-06	64
19	Screw Stainless Steel 1/4-20 x 1 1/4" Hex Head	20111-25	12
20	Bearing Washer	CLB-310	12
21	Broiler Bearing	70202-03	12
22	Bearing Bracket	CLB-401	12
23	Nut Hex Acorn 1/4-20 Stainless Steel	20301-29	8
24	Carriage Assembly	CLB-002	2
25	Heat Shield with Clips	CLB-420	2
26	Heat Shield #2	CLB-425	2
27	Rack	50200-80	2
28	Rear Firewall	CLB-220	1
29	Can Wire Support	CLB-320	2
30	Main Stack	CLB-331	1
31	Back	CLB-210	1
32	Vent Trim	CLB-211	2
33	Panel Vent Stack	CLB-244	1
34	Panel Vent Top	CLB-243	1
35	Wire Harness	CLB-502	1
36	2 Heat Switch – 25 Amp	30304-32	4
Not Shown	7½" Leg with adjustable round toe	72500-13	4

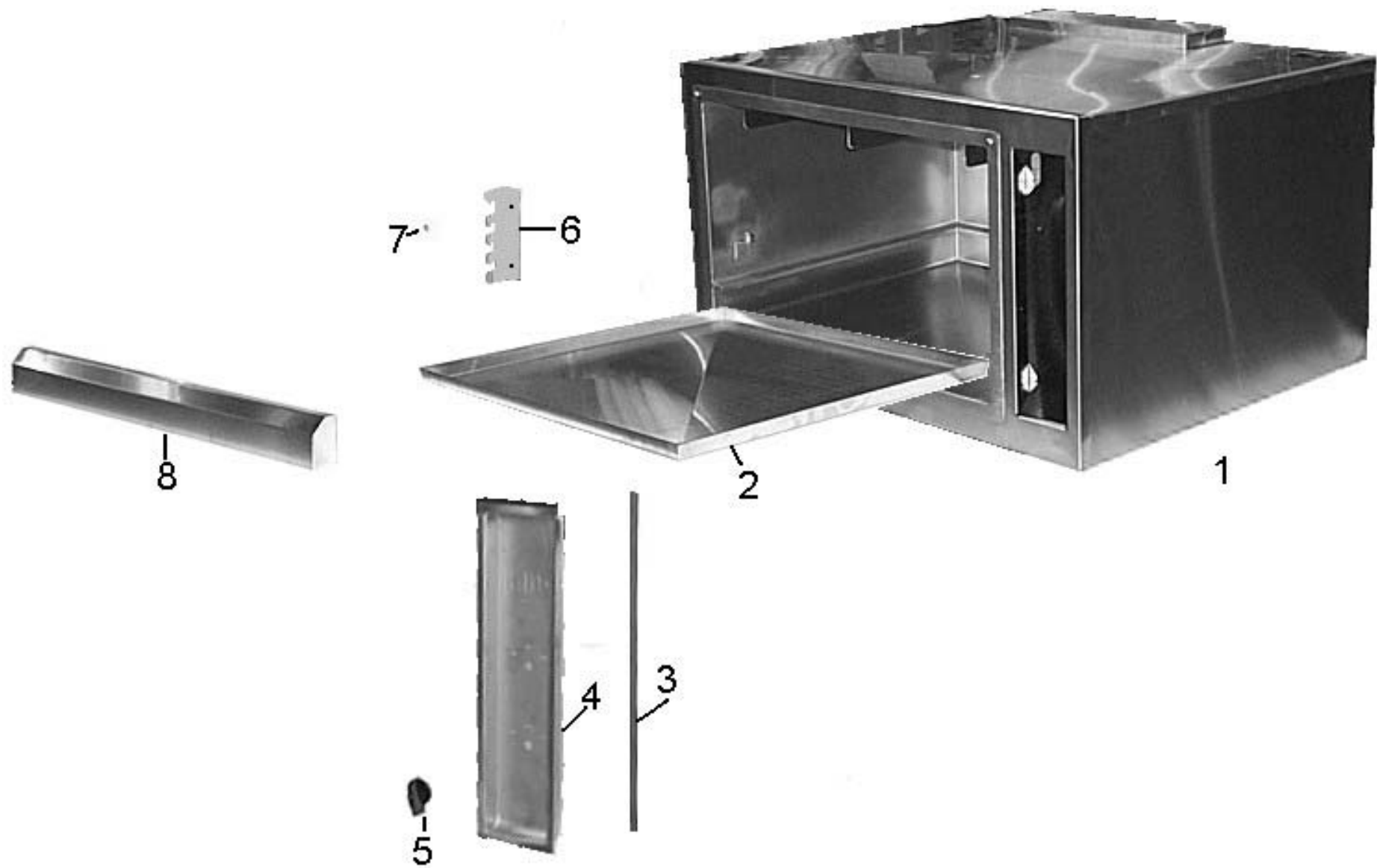

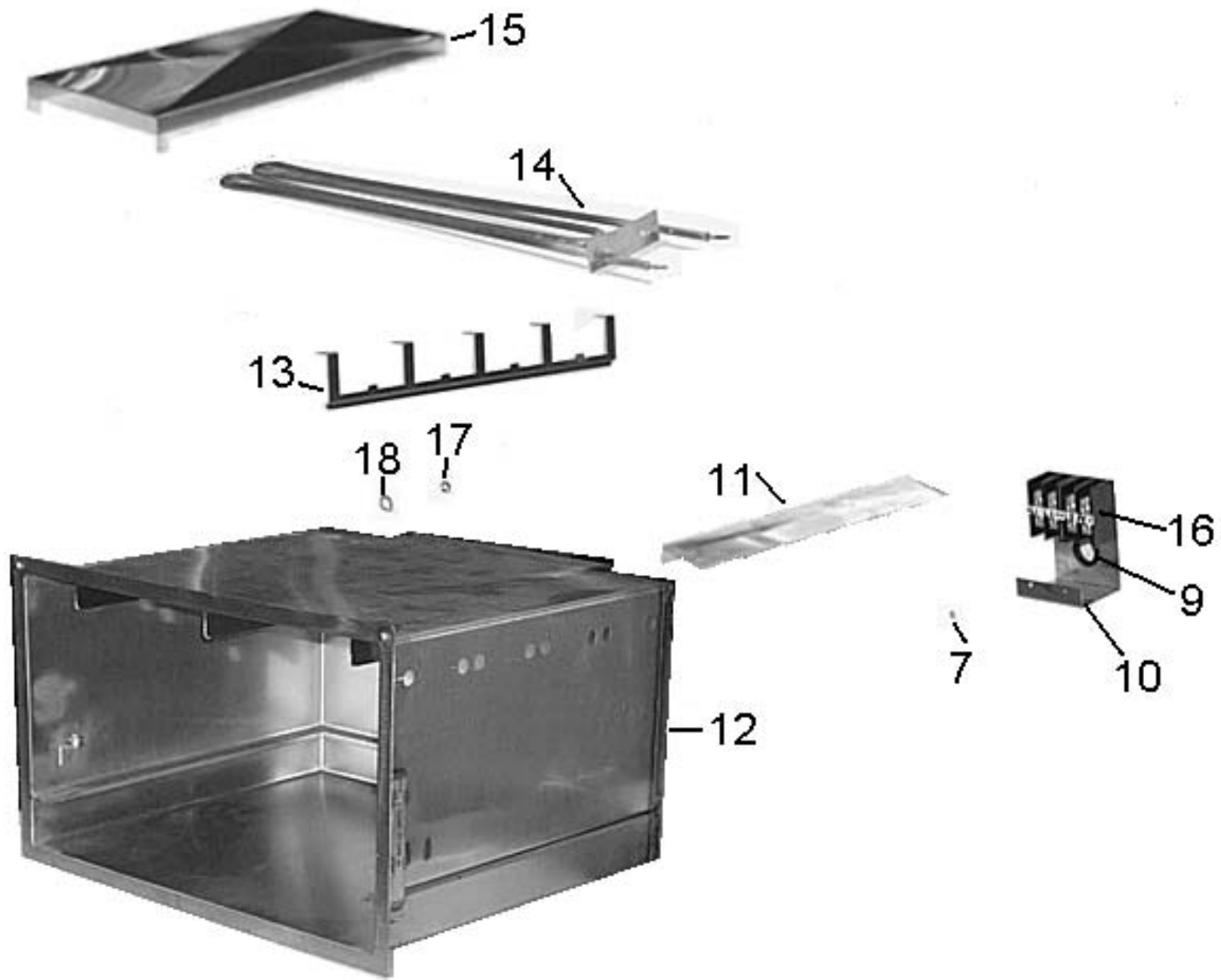

27

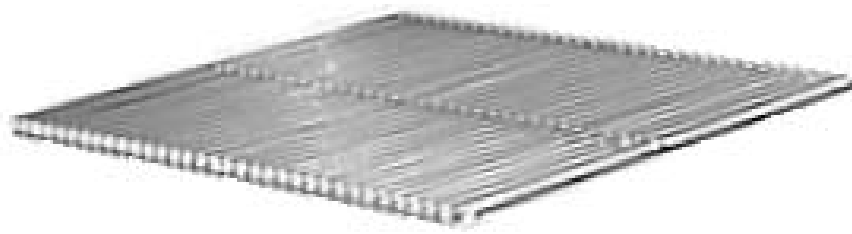

25



26



24

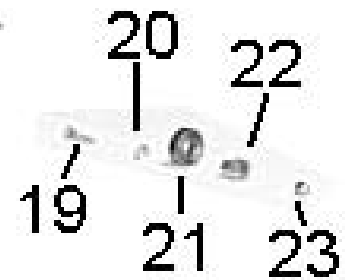

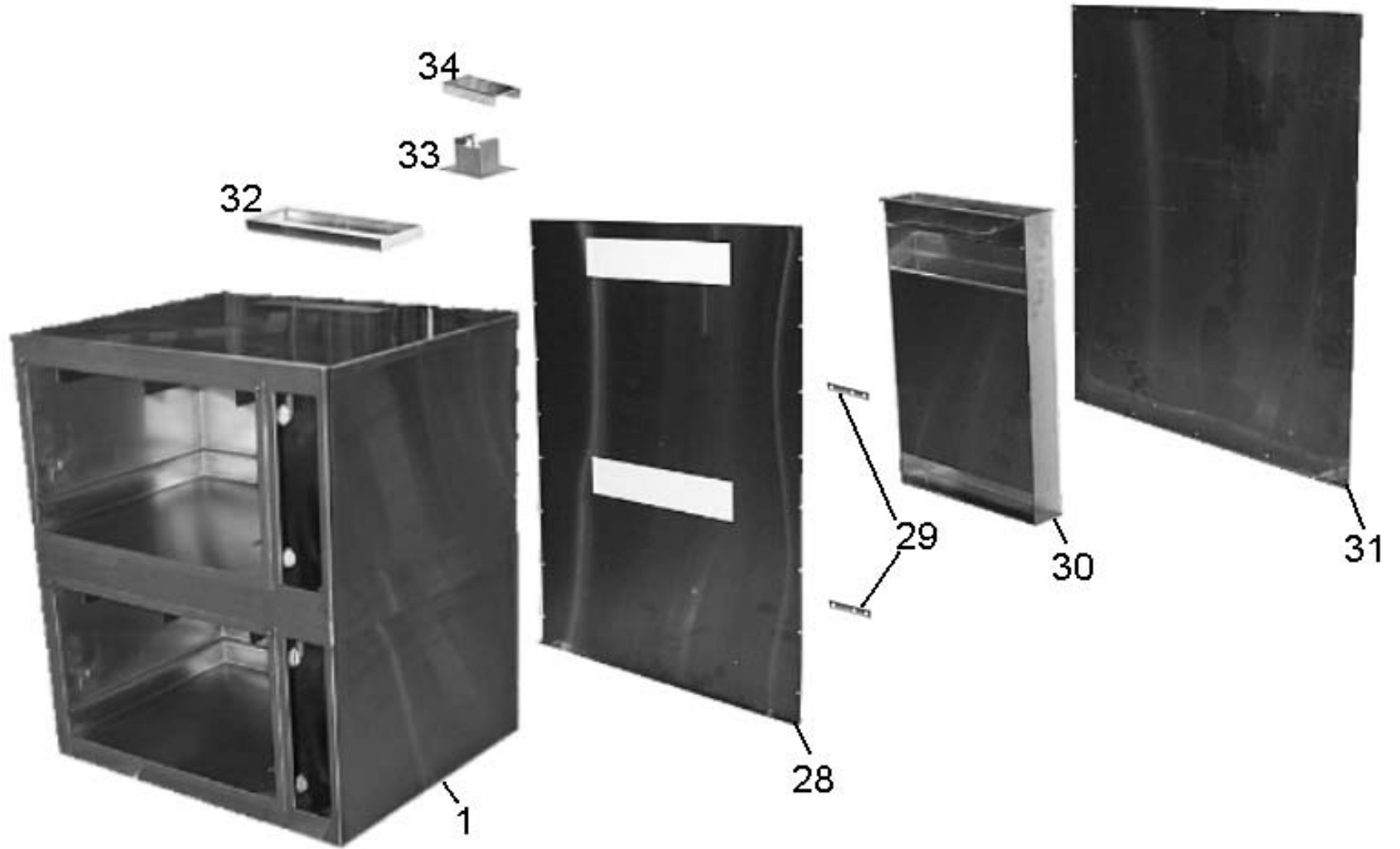

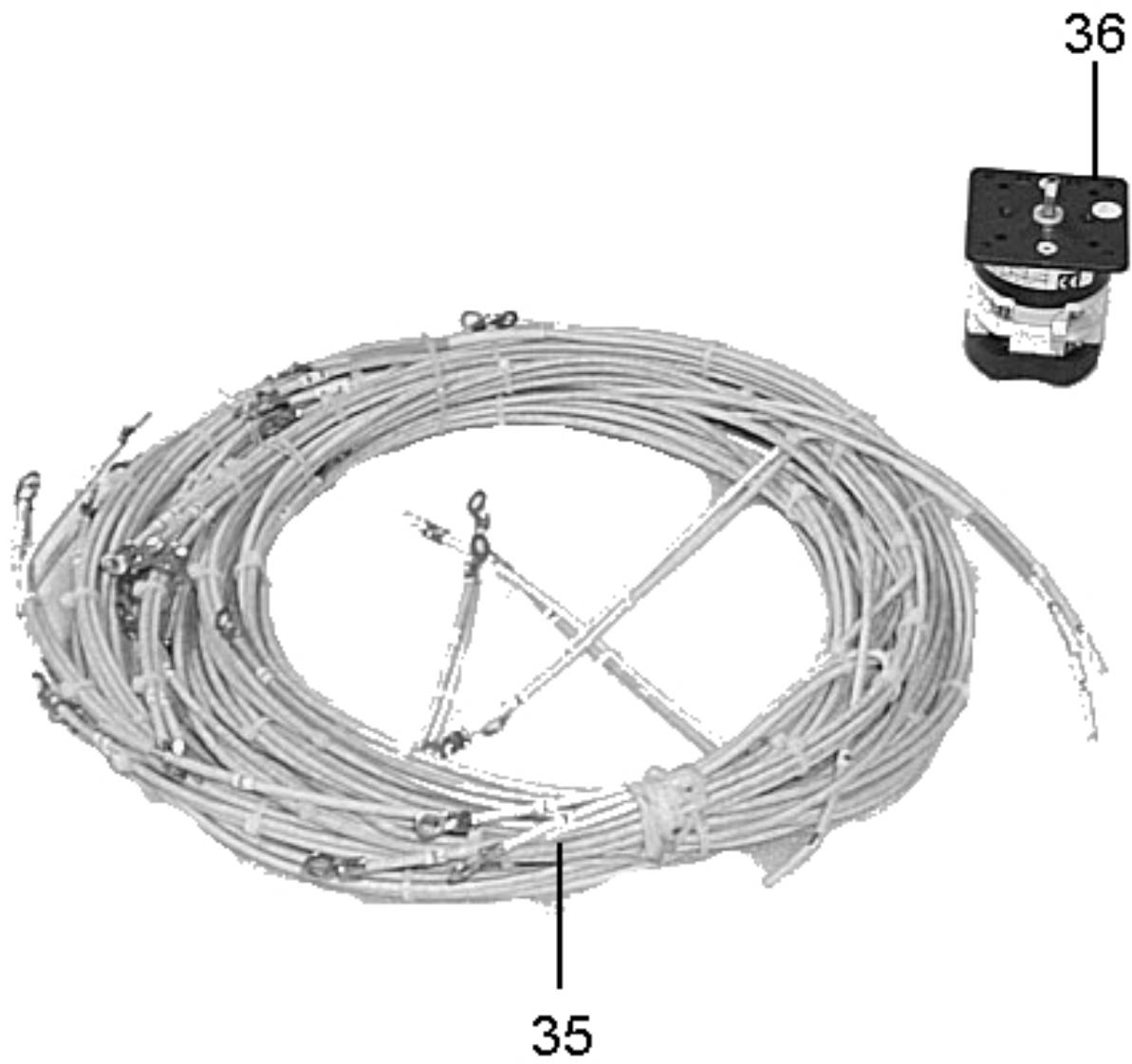

WIRING DIAGRAM

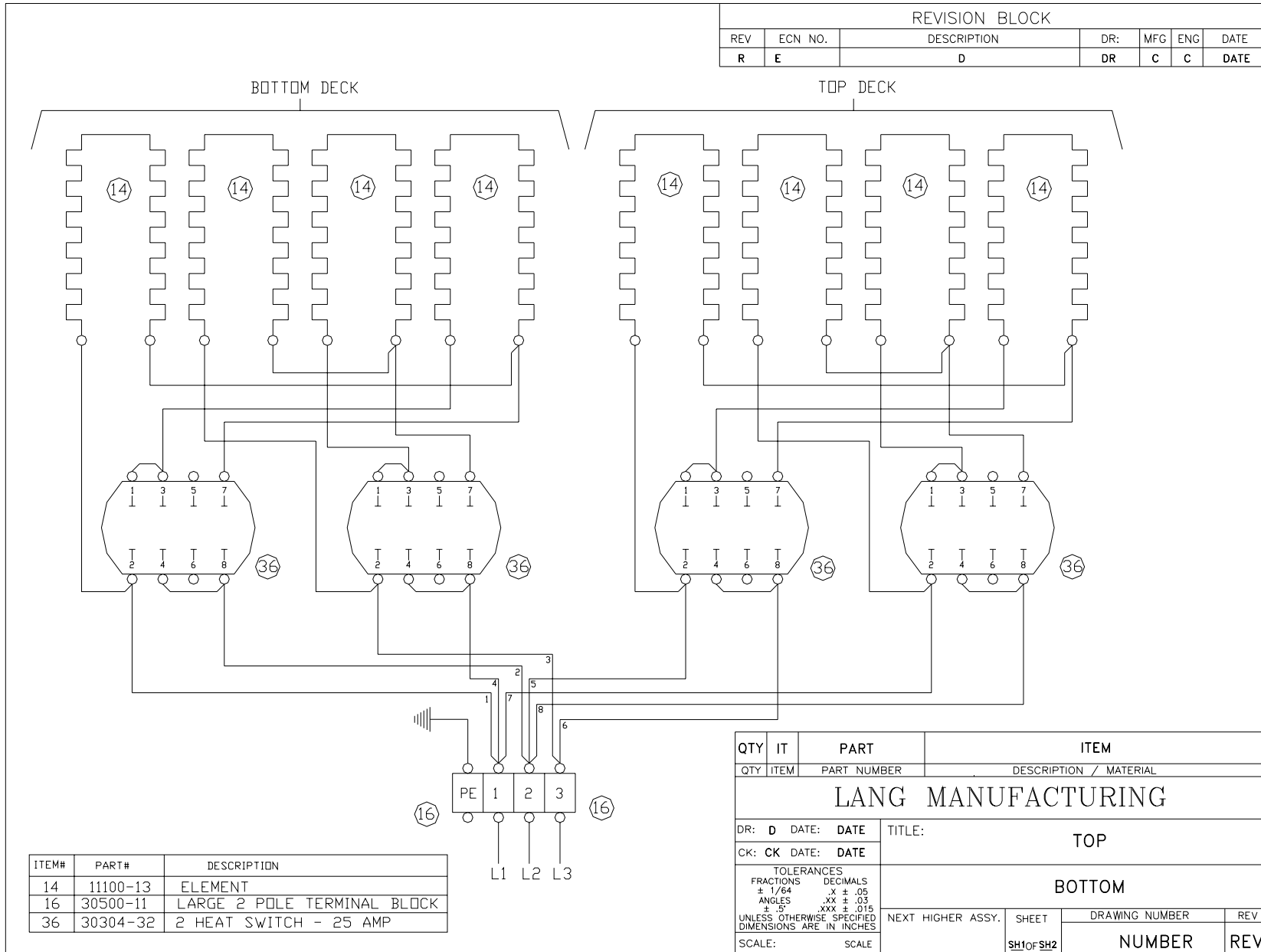

REVISION BLOCK						
REV	ECN NO.	DESCRIPTION	DR:	MFG	ENG	DATE
R	E	D	DR	C	C	DATE

ITEM#	PART#	DESCRIPTION
14	11100-13	ELEMENT
16	30500-11	LARGE 2 POLE TERMINAL BLOCK
36	30304-32	2 HEAT SWITCH - 25 AMP

QTY	IT	PART	ITEM
QTY	ITEM	PART NUMBER	DESCRIPTION / MATERIAL
LANG MANUFACTURING			
DR: D		DATE: DATE	TITLE: TOP
CK: CK		DATE: DATE	BOTTOM
TOLERANCES FRACTIONS ± 1/64 DECIMALS .XX ± .05 ANGLES .XX ± .03 ± .5° .XXX ± .015 UNLESS OTHERWISE SPECIFIED DIMENSIONS ARE IN INCHES			NEXT HIGHER ASSY. SHEET DRAWING NUMBER REV
SCALE: SCALE		SH1 OF SH2	NUMBER REV