

S6161-KW-FSE-010/34931
0910-LP-327-9700

OPERATION AND SERVICE MANUAL
FOR
SHIPBOARD ELECTRIC CONVECTION OVENS
MODEL NUMBERS ECO-6M, ECO-7M, ECO-8M, and ECO-
9M

LANG MANUFACTURING COMPANY
6500 MERRILL CREEK PARKWAY
EVERETT, WA 98203
FSCM 34931

DISTRIBUTION STATEMENT

THIS PUBLICATION IS REQUIRED FOR OFFICIAL USE OR FOR ADMINISTRATIVE OR OPERATIONAL PURPOSES. DISTRIBUTION IS LIMITED TO U.S. GOVERNMENT AGENCIES ONLY. OTHER REQUESTS FOR THIS DOCUMENT MUST BE REFERRED TO COMMANDER, NAVAL SEA SYSTEMS COMMAND, SEA 09, WASHINGTON, DC 20362

SUPERCEDURE NOTICE

S6161-KW-FSE-010/34931 DATED JANUARY 2006
CANCELS AND SUPERCEDES S6161-KW-FSE-010/34931
DATED MAY 1999
AND ALL CHANGES THERETO

MANUAL SUPPLEMENT FOR MARINE EQUIPMENT

THIS EQUIPMENT IS APPROVED FOR INSTALLATION ONLY ON VESSELS GREATER THAN 65 FEET IN LENGTH IN ACCORDANCE WITH USCG REGULATIONS IN TITLE 46 CFR 110-113.

ANY WIRING USED IN THE INSTALLATION OF THIS APPLIANCE MUST BE STRANDED COPPER.

IDENTIFYING TECHNICAL PUBLICATION SHEET

1. IDENTIFICATION DATA: LANG MFG. CO. MODELS ECO-6M, ECO-7M, ECO-8M, & ECO-9M.
2. PURPOSE: THIS TECHNICAL PUBLICATION IS ISSUED FOR THE PURPOSE OF IDENTIFYING AN AUTHORIZED TECHNICAL MANUAL FOR NAVY USE AND FOR PROVIDING SUPPLEMENTAL TECHNICAL INFORMATION.
 - A. MANUFACTURER: LANG MFG. CO.
 - B. CONTRACT NUMBER: DLA400-91-M-5159
 - C. EQUIPMENT: ELECTRIC CONVECTION OVEN, MODEL # ECO-6M, ECO-7M, ECO-8M, & ECO-9M.
 - D. REQUISITION NUMBER: NOT REFERENCED
 - E. NATIONAL STOCK NUMBER (NSN): 7310-01-314-7939
 - F. TITLE: MAINTENANCE MANUAL FOR ELECTRIC CONVECTION OVEN ECO-6M, ECO-7M, ECO-8M, & ECO-9M
 - G. DATE OF PUBLICATION: JANUARY 2006
 - H. PREPARING ACTIVITY: DEFENSE GENERAL SUPPLY CENTER
 - I. APPLICABLE TMCR NUMBER: NDMS 880393-000
 - J. EXTENT OF PROPOSED SUPPLEMENTAL DATA (10% MAXIMUM): 1%
 - K. LIST OF TECHNICAL MANUAL FOR THIS EQUIPMENT PROCURED UNDER ANOTHER CONTACT:
3. ADDITIONAL COPIES: ADDITIONAL COPIES ARE AVAILABLE FROM:

NAVAL PUBLICATION AND FORMS CENTER
5801 TABOR AVENUE
PHILADELPHIA, PA 19120-5099

4. COVER: THE TECHNICAL MANUAL OUTSIDE COVER SHALL CONTAIN THE FOLLOWING STATEMENTS:

PUBLISHED BY DIRECTION OF COMMANDER, NAVAL SEA SYSTEMS
COMMAND

THIS PUBLICATION IS REQUIRED FOR OFFICIAL USE OR FOR ADMINISTRATIVE OR OPERATIONAL PURPOSES. DISTRIBUTION IS LIMITED TO U.S. GOVERNMENT AGENCIES ONLY. OTHER REQUESTS MUST BE REFERRED TO COMMANDER, NAVAL SEA SYSTEMS COMMAND, SEA 09, WASHINGTON, DC 20362.

APPROVAL AND PROCUREMENT RECORD

APPROVAL DATA FOR: LANG ELECTRIC CONVECTION OVEN MODELS ECO-6M, ECO-7M, ECO-8M, & ECO-9M.

TITLE OF MANUAL: MAINTENANCE MANUAL FOR: ELECTRIC CONVECTION OVEN MODELS: ECO-6M, ECO-7M, ECO-8M, & ECO-9M.

APPROVAL AUTHORITY: NAVAL SHIP SYSTEMS ENGINEERING STATION

CONTRACT NUMBER	NSN	# OF UNITS	APL/CID
DLA400-86-C-5292	7310-01-227-8214	58	430280135
DLA400-88-C-5327	7310-01-277-4105	97	430280144
DLA400-89-C-0442	7310-01-290-0463	13	430280147
DLA400-91-M-5159	7310-01-314-7939	5	430280155

REMARKS:

DATE: JANUARY 2006

CERTIFICATION:

IT IS HEREBY CERTIFIED THAT THE TECHNICAL MANUAL PROVIDED UNDER CONTRACT NUMBER DLA400-91-M-5159 FOR LANG ECO-6M, ECO-7M, ECO-8M, & ECO-9M HAS BEEN APPROVED BY THE APPROVAL DATA SHOWN ABOVE:

DIRECTOR, GOV'T CONTRACTS

LANG MANUFACTURING COMPANY

FSCM / CAGE #: 34931

CHANGE RECORD

Change no.	Date	Title and/or Brief Description	Signature of Validating Officer

TABLE OF CONTENTS

CHAPTER	PAGE
1. TABLE OF CONTENTS	6
2. LIST OF ILLUSTRATIONS	7
3. READ FIRST	8
4. SPECIFICATIONS	11
5. EQUIPMENT DESCRIPTION	14
6. INSTALLATION	16
7. OPERATION.....	18
8. MAINTENANCE & TROUBLESHOOTING PROCEDURES	19
9. PARTS LIST	24
10. WIRING DIAGRAMS	26

LIST OF ILLUSTRATIONS

FIGURE #	TITLE OF ILLUSTRATION	PAGE #
1	Picture of Oven	11
1A	Specifications	12 & 13
2	Leg Installation	17
3	Stacking Instructions	17
4	Exploded View	23
5	Wiring Diagram 208/240 VAC	26
6	Wiring Diagram 440 VAC	27

- CAUTION:** THE OVEN IS EXTREMELY HEAVY. FOR SAFE HANDLING, INSTALLER SHOULD OBTAIN HELP AS NEEDED, OR EMPLOY APPROPRIATE MATERIALS HANDLING EQUIPMENT (SUCH AS A FORKLIFT, DOLLY, OR PALLET JACK) TO REMOVE THE UNIT FROM THE SKID AND MOVE IT TO THE PLACE OF INSTALLATION.
- CAUTION:** ANY STAND, COUNTER OR OTHER DEVICE ON WHICH OVEN WILL BE LOCATED MUST BE DESIGNED TO SUPPORT THE WEIGHT OF THE OVEN(S).
- CAUTION:** SHIPPING STRAPS ARE UNDER TENSION AND CAN SNAP BACK WHEN CUT.
- DANGER:** THIS APPLIANCE MUST BE GROUNDED AT THE TERMINAL PROVIDED. FAILURE TO GROUND THE APPLIANCE COULD RESULT IN ELECTROCUTION AND DEATH.
- WARNING:** INSTALLATION OF THE UNIT MUST BE DONE BY PERSONNEL QUALIFIED TO WORK WITH ELECTRICITY AND PLUMBING. IMPROPER INSTALLATION CAN CAUSE INJURY TO PERSONNEL AND/OR DAMAGE TO EQUIPMENT. UNIT MUST BE INSTALLED IN ACCORDANCE WITH ALL APPLICABLE CODES.
- NOTICE:** The data plate is located on the door of the oven. The oven voltage, wattage, serial number, wire size, and clearance specifications are on the data plate. This information should be carefully read and understood before proceeding with the installation.
- NOTICE:** The installation of any components such as a vent hood, grease extractors, fire extinguisher systems, must conform to their applicable National, State and locally recognized installation standards.
- NOTICE:** During the first few hours of operation you may notice a small amount of smoke coming off the oven, and a faint odor from the smoke. This is normal for a new oven and will disappear after the first few hours of use.
- CAUTION:** ALWAYS KEEP THE AREA NEAR THE APPLIANCE FREE FROM COMBUSTIBLE MATERIALS.
- CAUTION:** KEEP FLOOR IN FRONT OF EQUIPMENT CLEAN AND DRY. IF SPILLS OCCUR, CLEAN IMMEDIATELY, TO AVOID THE DANGER OF SLIPS OR FALLS.



IMPORTANT

READ FIRST

IMPORTANT

WARNING: KEEP WATER AND SOLUTIONS OUT OF CONTROLS. NEVER SPRAY OR HOSE CONTROL CONSOLE, ELECTRICAL CONNECTIONS, ETC.

CAUTION: MOST CLEANERS ARE HARMFUL TO THE SKIN, EYES, MUCOUS MEMBRANES AND CLOTHING. PRECAUTIONS SHOULD BE TAKEN TO WEAR RUBBER GLOVES, GOGGLES OR FACE SHIELD AND PROTECTIVE CLOTHING. CAREFULLY READ THE WARNING AND FOLLOW THE DIRECTIONS ON THE LABEL OF THE CLEANER TO BE USED.

NOTICE: Service on this, or any other, LANG appliance must be performed by qualified personnel only. Consult your authorized service station directory or call the factory at 1-800-224-LANG (5264), or WWW.LANGWORLD.COM For the service station nearest you.

WARNING: BOTH HIGH AND LOW VOLTAGES ARE PRESENT INSIDE THIS APPLIANCE WHEN THE UNIT IS PLUGGED/WIRED INTO A LIVE RECEPTACLE. BEFORE REPLACING ANY PARTS, DISCONNECT THE UNIT FROM THE ELECTRIC POWER SUPPLY.

CAUTION: USE OF ANY REPLACEMENT PARTS OTHER THAN THOSE SUPPLIED BY LANG OR THEIR AUTHORIZED DISTRIBUTORS CAN CAUSE BODILY INJURY TO THE OPERATOR AND DAMAGE TO THE EQUIPMENT AND WILL VOID ALL WARRANTIES.



LANG MANUFACTURING COMPANY
MANUAL FOR MODEL ECO
ELECTRIC CONVECTION OVENS

ISSUE DATE JANUARY 2006

LANG MANUFACTURING COMPANY
6500 MERRILL CREEK PARKWAY
EVERETT, WA 98203

CONVECTION OVENS PER: MIL-0-0043633 E

<u>MIL SPEC</u>	<u>LANG MODEL NUMBER</u>	<u>SPECIFIC NSN</u>
Type I, Size 1	ECO-7	
Type I, Size 1 N.S.A. *	ECO-7M	7310-01-290-0463
Type I, Size 2	ECO-6	
Type I, Size 2 N.S.A. *	ECO-6M	7310-01-314-7939
Type II, Size 1	ECO-9	7310-01-230-0559
Type II, Size 1 N.S.A. *	ECO-9M	7310-01-277-4105
Type II, Size 2	ECO-8	
Type II, Size 2 N.S.A. *	ECO-8M	7310-01-227-8214

* N.S.A. for “Naval Shipboard Application”. All components will fit through a 26” X 66” watertight door.

Lang

- **Hatchable equipment!**
Equipment easily passes through 26" x 66" watertight doorway. No expensive hull cuts necessary.
- Available in two (2) sizes: Standard or Extra deep.
- **Heavy Duty Marine Door Latches.**
Secure all oven doors, drip pans, crumb trays and grease drawers. Stainless steel flatbar construction.
- **All Stainless Steel Construction** - inside and out. More corrosion-resistant than 430 stainless. 12- and 16-gauge sheetmetal to withstand physical abuse in tight, busy galleys.
- Two-speed motor and interior oven light.
- Double-pane windowed doors.
- U.L. and N.S.F. Listed.
- Designed and manufactured to comply with military specifications MIL-0-0043633E. For both land base and Naval Shipboard application.
- Positive Door Locks.
- Five Oven Racks.



LANG MANUFACTURING COMPANY
6500 Merrill Creek Parkway
Everett, WA 98203
TOLL FREE (800) 882-6368
PHONE (425) 349-2400
SERVICE (800) 224-5264
FAX (425) 349-2518

LANG MILITARY CONVECTION OVENS

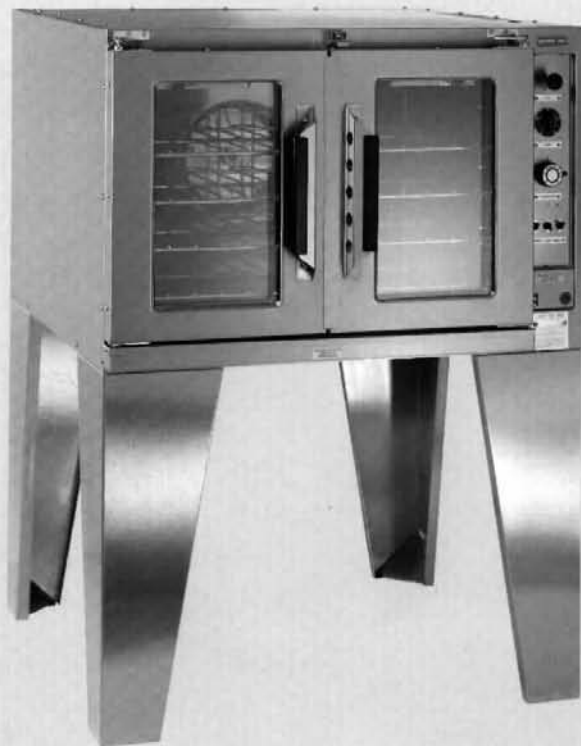

Meets Military Specifications MIL-0-0043633E



Figure # 1

Specifications subject to change without notice.

Designed and manufactured to comply with military specification MIL-0-0043633E. For both land base and Naval Shipboard application. Available in standard and extra deep.

INTERIOR OVEN DIMENSIONS	
STANDARD DEPTH:	
20" HIGH	22" DEEP
29" HIGH	29" DEEP
EXTRA DEEP:	
20" HIGH	29" DEEP
29" HIGH	29" DEEP

WEIGHT	
ECO-6	500#
ECO-7	450#
ECO-8	1000#
ECO-9	900#

MIL-0-0043633E CONVECTION OVENS

MIL-0-0043633E Classifications:

- TYPE I - One Oven Compartment
 - TYPE II - Two Oven Compartments
 - SIZE 1 - Standard Depth
 - SIZE 2 - Extra Deep Oven Cavity
- Navy Shipboard Application

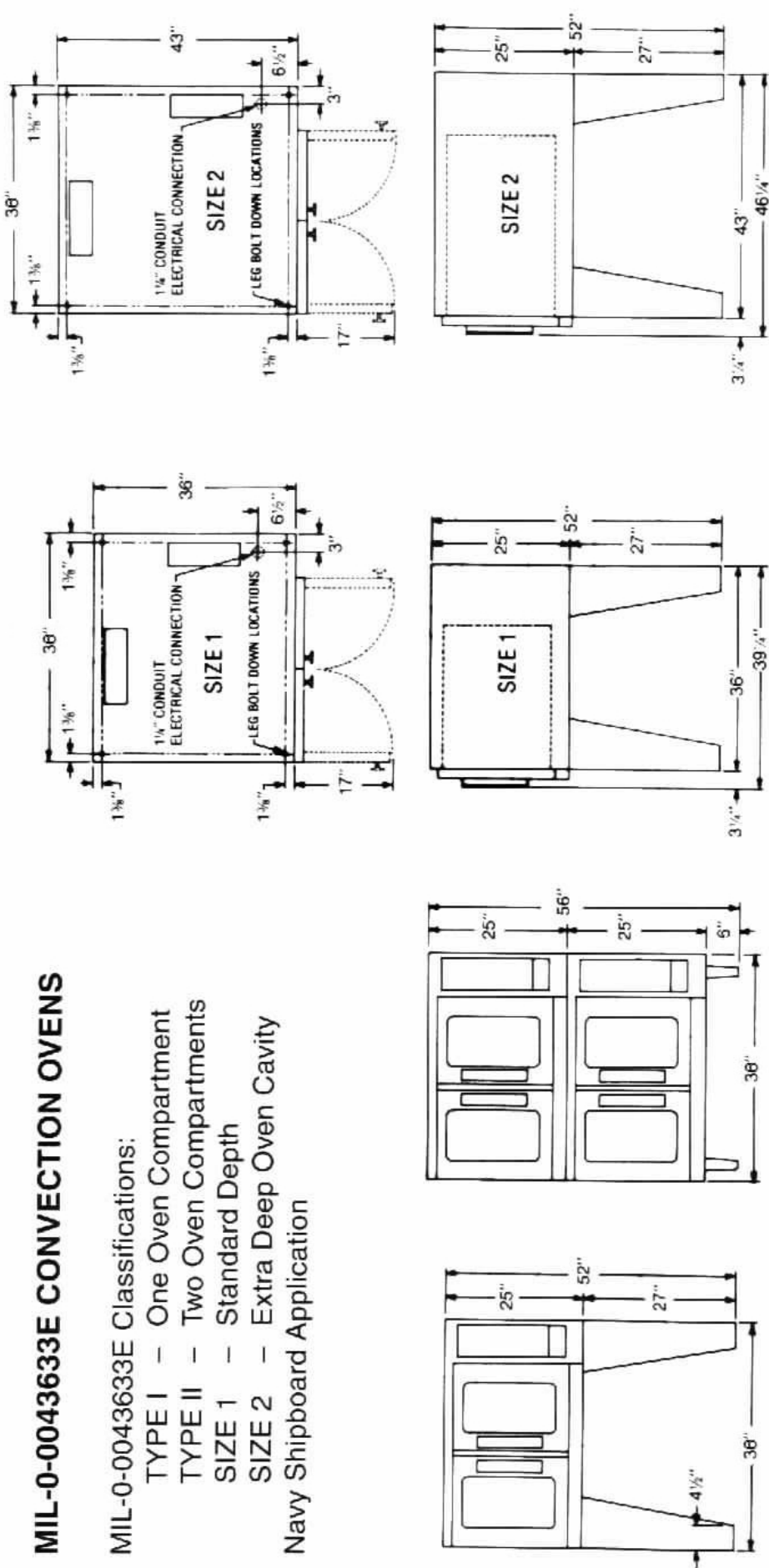

Figure # 1A

MILITARY SPECIFICATIONS AND ELECTRICAL DATA																							
ECO CONVECTION OVENS																							
MODEL NO.	MIL-0-0043633E SPECIFICATION DESCRIPTION		NSN	APL	TECH. MAN. NO.	TOTAL K.W. CONN.	NOMINAL AMPS PER LINE																
	TYPE	SIZE					*N.S.A.	208 VOLT			240 VOLT			440 VOLT			SINGLE PHASE						
								L ¹	L ²	L ³	L ¹	L ²	L ³	L ¹	L ²	L ³	208V	240V					
ECO-6	I	2	NO																				
ECO-6M	I	2	YES	7310-01-314-7939		11.5	36.5	36.5	22.9	28.3	28.3	26.5	16.6	16.6	11.2	55.3	47.9						
ECO-7	I	1	NO																				
ECO-7M	I	1	YES	7310-01-290-0463	CONTACT FACTORY																		
ECO-8	II	2	NO																				
ECO-8M	II	2	YES	7310-01-227-8214		23.0	59.4	72.9	59.4	54.8	54.8	56.6	27.9	33.1	27.9	110.6	95.8						
ECO-9	II	1	NO																				
ECO-9M	II	1	YES	7310-01-277-4105																			

*FOR NAVAL SHIPBOARD APPLICATION

WHEN ORDERING SPECIFY VOLTAGE AND PHASE

Specifications subject to change without notice.

LANG MANUFACTURING COMPANY

6500 Merrill Creek Parkway, Everett, WA 98203 U.S.A.

PRINTED IN U.S.A.

61209-01 6/88

TOLL FREE 800/882-6368
PHONE 425/349-2400
FAX 425/349-2518

Figure # 1A

EQUIPMENT DESCRIPTION

INTRODUCTION

This manual contains the necessary information to install, operate, maintain, and service the Lang model ECO convection ovens.

Replacement parts should be genuine Lang parts. Failure to use genuine Lang replacement parts may result in malfunction of the appliance or possible injury to the contractor or service technician.

PURPOSE AND FUNCTION

Convection ovens constantly circulate air over the product. This removes a layer of moisture and cool air from around the product. This allows heat to penetrate the product more quickly. Cooking times are shortened and cooking temperatures are reduced.

CAPABILITIES

This convection oven is suitable for cooking all types of products requiring baking or roasting.

ENVIRONMENTAL REQUIREMENTS

The following minimum spacing from combustible surfaces must be maintained: Sides – 2 inches, Back – 2 inches

ITEMS FURNISHED (Listed by Model Number)

Model ECO-6 or ECO-6M

- 1 ea. Oven, Type I, Size 2
- 4 ea. Legs
- 16 ea. 3/8 – 16 x 5/8 Bolts (For mounting legs)
- 16 ea. 3/8 – 16 Hex Nuts (For mounting legs)
- 32 ea. Washers (For mounting legs)
- 2 ea. Rack Slides, Extra Deep
- 5 ea. Racks, Extra Deep
- 2 ea. Manuals, Technical

Model ECO-7 or ECO-7M

- 1 ea. Oven, Type I, Size 1
- 4 ea. Legs
- 16 ea. 3/8 – 16 x 5/8 Bolts (For mounting legs)
- 16 ea. 3/8 – 16 Hex Nuts (For mounting legs)
- 32 ea. Washers (For mounting legs)
- 2 ea. Rack Slides, Standard Depth
- 5 ea. Racks, Standard Depth
- 2 ea. Manuals, Technical

EQUIPMENT DESCRIPTION CONT'D

Model ECO-8 or ECO-8M

- 2 ea. Oven, Type II, Size 2
- 4 ea. Legs
- 16 ea. 3/8 – 16 x 5/8 Bolts (For mounting legs)
- 16 ea. 3/8 – 16 Hex Nuts (For mounting legs)
- 32 ea. Washers (For mounting legs)
- 4 ea. Rack Slides, Extra Deep
- 10 ea. Racks, Extra Deep
- 2 ea. Manuals, Technical
- 1 ea. Stacking Kit

Model ECO-9 or ECO-9M

- 2 ea. Oven, Type II, Size 1
- 4 ea. Legs
- 16 ea. 3/8 – 16 x 5/8 Bolts (For mounting legs)
- 16 ea. 3/8 – 16 Hex Nuts (For mounting legs)
- 32 ea. Washers (For mounting legs)
- 4 ea. Rack Slides, Standard Depth
- 10 ea. Racks, Standard Depth
- 2 ea. Manuals, Technical
- 1 ea. Stacking Kit

ITEMS REQUIRED

An adequate supply of wire suitable for the loads and application specified on the data sheet must be provided. The data sheet is on Page 4 of this manual.

TOOLS AND TEST EQUIPMENT REQUIRED

For Installation:

- 1 set – Open End Wrenches
- 1 – Flat Blade Screwdriver
- 1 – Phillips Screwdriver
- 1 – Wire Cutter/Stripper
- 1 – AMP Probe
- 1 – Voltmeter
- 1 – Drill
- 4 – #27 Drill Bits

For Service: All of the above plus –

- 1 – Needle Nose Pliers
- 1 – Crimping Pliers
- 1 – Allen Wrench Set
- 1 – Temperature Meter
- 1 – Very Small Flat Blade Screwdriver
- 1 – #10 Square Drive Screwdriver

INSTALLATION

CAUTION: THE OVEN IS EXTREMELY HEAVY. FOR SAFE HANDLING, INSTALLER SHOULD OBTAIN HELP AS NEEDED, OR EMPLOY APPROPRIATE MATERIALS HANDLING EQUIPMENT (SUCH AS A FORKLIFT, DOLLY, OR PALLET JACK) TO REMOVE THE UNIT FROM THE SKID AND MOVE IT TO THE PLACE OF INSTALLATION.



CAUTION: ANY STAND, COUNTER OR OTHER DEVICE ON WHICH OVEN WILL BE LOCATED MUST BE DESIGNED TO SUPPORT THE WEIGHT OF THE OVEN(S).



CAUTION: SHIPPING STRAPS ARE UNDER TENSION AND CAN SNAP BACK WHEN CUT.



DANGER: THIS APPLIANCE MUST BE GROUNDED AT THE TERMINAL PROVIDED. FAILURE TO GROUND THE APPLIANCE COULD RESULT IN ELECTROCUTION AND DEATH.



WARNING: INSTALLATION OF THE UNIT MUST BE DONE BY PERSONNEL QUALIFIED TO WORK WITH ELECTRICITY AND PLUMBING. IMPROPER INSTALLATION CAN CAUSE INJURY TO PERSONNEL AND/OR DAMAGE TO EQUIPMENT. UNIT MUST BE INSTALLED IN ACCORDANCE WITH ALL APPLICABLE CODES.



NOTICE: The data plate is located on the door of the oven. The oven voltage, wattage, serial number, wire size, and clearance specifications are on the data plate. This information should be carefully read and understood before proceeding with the installation.



NOTICE: The installation of any components such as a vent hood, grease extractors, fire extinguisher systems, must conform to their applicable National, State and locally recognized installation standards.



INSPECTION AND INSTALLATION

Upon receipt of the oven(s) any damage should be noted on the Bill of Lading and countersigned by the carrier. If concealed damage is discovered the carrier should be notified. All claims must be filed with the carrier.

Move the crate(s) containing the oven(s) as close to the place of installation as possible before removing the protective crating. Uncrate the oven(s) and move them as close as practical to the final installation site.

Bolt the legs to the bottom oven, (See figure #2). Use the 3/8 – 16 x 5/8 Bolts, Hex Nuts and Washers provided. There are pre-punched holes provided in the legs and oven bottom to aid in leg installation. Now the oven can be set upright in or near its final position.

INSTALLATION

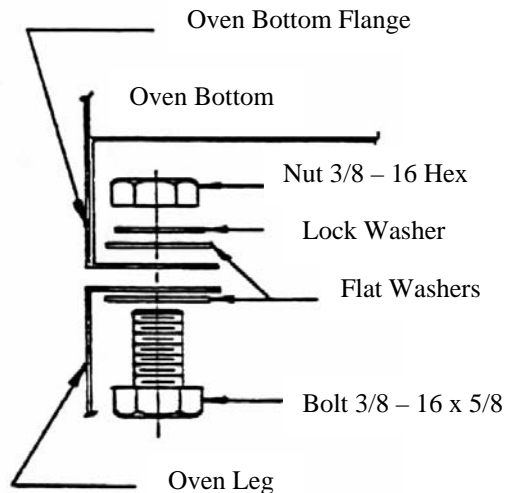

FIGURE # 2

For single cavity ovens, they can now be connected to power through the knockout in the bottom.

The oven can be placed in its final position and leveled. The oven is ready for initial start-up procedures now. (See page 17)

For two cavity ovens, place the upper oven on top of the bottom oven. Be careful to route the power supply wire between the two ovens using the holes provided. Do not pinch or cut the supply wires when stacking the ovens. Use the stacking kit provided to secure the top oven to the bottom oven. The stacking kit contains four (4) identical corner braces. One brace goes on each corner. Do the following for each corner: Put a brace on a corner. Drill pilot holes for the mounting screws using the pre-punched holes as a guide. Secure the top oven to the bottom oven with the sheet metal screws provided. (See figure #3)

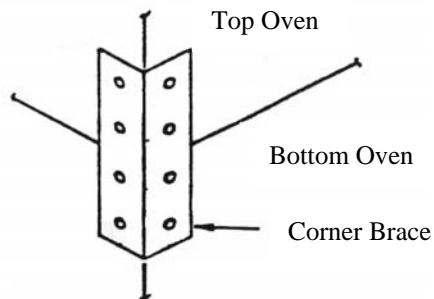

FIGURE # 3

Connect the power supply leads from the top oven to the power supply leads of the bottom oven and incoming power per the wiring diagram on Page 16 or 17.

Now the bottom oven can be connected to the incoming power supply through the knockout provided in the bottom of the oven. Be sure the power supply voltage matches the voltage specified on the nameplate located on the front of the oven! Then the oven can be placed in its final position and leveled. The oven is ready for initial start-up procedures now. See page 17.

OPERATION

NOTICE: During the first few hours of operation you may notice a small amount of smoke coming off the oven, and a faint odor from the smoke. This is normal for a new oven and will disappear after the first few hours of use.

CAUTION: ALWAYS KEEP THE AREA NEAR THE APPLIANCE FREE FROM COMBUSTIBLE MATERIALS.

CAUTION: KEEP FLOOR IN FRONT OF EQUIPMENT CLEAN AND DRY. IF SPILLS OCCUR, CLEAN IMMEDIATELY, TO AVOID THE DANGER OF SLIPS OR FALLS.



OPERATING INSTRUCTIONS

Each oven has the following controls:

Vent, Timer, Temperature, Power Switch, Light Switch and Motor Speed Switch.

Vent – Pull to Open, Push to close.

Timer – Adjust to desired setting.

Temperature – Turn to desired cooking temperature.

Power Switch – Pull up to turn oven ON, push down to turn oven OFF.

Light Switch – Pull up to turn oven light ON, release and oven light goes out automatically.

Motor Speed Switch – Pull up for High Speed, push down for low speed.

INITIAL START-UP

Set oven(s) at 350° and allow oven to operate empty for 3 hours. After this time, the oven is ready for use.

NORMAL OPERATION

Turn the Power Switch On, turn to the desired temperature and select motor speed. (Hi or Low)

MAINTENANCE

Wash the stainless interior & exterior often with a solution of hot water and detergent to prevent grease build-up and preserve the oven's appearance.

Wipe up spillage as soon as possible. Never use scouring powder. It is difficult to remove completely and a residue build-up can damage the oven.

The oven racks, slides and stainless steel oven liners are removable for easier cleaning of the oven interior.

MAINTENANCE AND TROUBLESHOOTING

WARNING: KEEP WATER AND SOLUTIONS OUT OF CONTROLS. NEVER SPRAY OR HOSE CONTROL CONSOLE, ELECTRICAL CONNECTIONS, ETC.



CAUTION: MOST CLEANERS ARE HARMFUL TO THE SKIN, EYES, MUCOUS MEMBRANES AND CLOTHING. PRECAUTIONS SHOULD BE TAKEN TO WEAR RUBBER GLOVES, GOGGLES OR FACE SHIELD AND PROTECTIVE CLOTHING. CAREFULLY READ THE WARNING AND FOLLOW THE DIRECTIONS ON THE LABEL OF THE CLEANER TO BE USED.



NOTICE: Service on this, or any other, LANG appliance must be performed by qualified personnel only. Consult your authorized service station directory or call the factory at 1-800-224-LANG (5264), or WWW.LANGWORLD.COM For the service station nearest you.



WARNING: BOTH HIGH AND LOW VOLTAGES ARE PRESENT INSIDE THIS APPLIANCE WHEN THE UNIT IS PLUGGED/WIRED INTO A LIVE RECEPTACLE. BEFORE REPLACING ANY PARTS, DISCONNECT THE UNIT FROM THE ELECTRIC POWER SUPPLY.



CAUTION: USE OF ANY REPLACEMENT PARTS OTHER THAN THOSE SUPPLIED BY LANG OR THEIR AUTHORIZED DISTRIBUTORS CAN CAUSE BODILY INJURY TO THE OPERATOR AND DAMAGE TO THE EQUIPMENT AND WILL VOID ALL WARRANTIES.



TROUBLESHOOTING GUIDE

SYMPTOM	PROBLEM	REMEDY
Oven will not turn on	<ul style="list-style-type: none"> * Internal Circuit Breakers off * Power supply circuit breakers off * Improperly Phased * Fuses Open 	<ul style="list-style-type: none"> * Turn on * Turn on * Phase per wiring diagram * Change fuses
Power Supply Circuit Breakers Trip	<ul style="list-style-type: none"> * Supply circuit breakers of insufficient size * Supply voltage & oven voltage do not match 	<ul style="list-style-type: none"> * Install proper size breakers * Change voltage to match oven
Internal circuit breakers trip	<ul style="list-style-type: none"> * Supply voltage & oven voltage do not match 	<ul style="list-style-type: none"> * Change voltage to match oven
Oven takes too long to bake and wont' maintain temperature	<ul style="list-style-type: none"> * Improperly phased 	<ul style="list-style-type: none"> * Phase oven to match power supply per wiring diagram

MAINTENANCE AND TROUBLESHOOTING CONT'D

PERFORMANCE AND INSPECTION

A periodic check of thermostat calibration should be performed. To check oven calibration attach a thermocouple to the mid-point of the thermostat bulb in the oven cavity. Turn the temperature dial to 350° and turn the oven ON. Wait approximately 20 minutes until the oven temperature has stabilized. If the average of the ON and OFF thermostat readings is within 10° of 350° the oven is in calibration. If not, remove the temperature knob and turn the small screw in the middle until oven is in calibration. Replace the knob and the oven is ready for normal operation.

MAJOR COMPONENT DISASSEMBLY, REPAIR, REPLACEMENT AND REASSEMBLY

(Refer to figure #4, page 22)

THERMOSTAT, CONTACTORS (RELAYS), SWITCHES

These parts are located behind the control panel assembly on the right hand side of each oven. Remove the screws attaching the control panel to the front of the oven. Slowly pull out the control panel until the component requiring replacement is accessible.

THERMOSTAT REPLACEMENT:

Inside the oven cavity remove the retaining clips holding the thermostat-sensing bulb in place. Feed the bulb through the oven wall into the control panel area. Remove the wires attached to the thermostat terminals. Remember the terminal each wire was on and attach the wires to the same terminal on the new thermostat. Remove the screws holding the old thermostat to the front of the control panel. Discard old thermostat. Mount the new thermostat to the control panel, carefully feed the sensing bulb through the oven wall, and reattach the sensing bulb to the oven side using the retaining clips removed earlier. Close control compartment. Restore power to oven. Refer to the "Performance and Inspection" section to verify proper operation of the new thermostat.

MAINTENANCE AND TROUBLESHOOTING CONT'D

ELEMENT REPLACEMENT:

The element is located inside the oven cavity. To replace the element, remove the baffle at the back of the oven. This will expose the elements to plain view and allow easy access. Remove the element mounting screws located near the top of the oven. Gently, pull the element into the oven cavity. There is enough wire connected to the element to allow easy access to the terminals located behind the element mounting plate. Move each wire from the existing terminal to the corresponding terminal on the new element. DO NOT mix up these wires! After all wires are transferred to the new element, feed the wire back through the access hole in the back of the oven and attach the element to the oven wall with the screws removed earlier. Replace the baffle. Refer to the “Initial Start-up” section to restore the oven to proper operation.

CONTACTOR (RELAY), SWITCH REPLACEMENT:

Pull out control panel as previously outlined. Remove the wires from the contactor or switch being changed. Place those wires on the corresponding terminal of the new part. Remove old part and mount new part with wires attached in the spot where the old part used to be. Reinstall the control panel, restore power to the oven. Turn oven on, set thermostat to 200° and allow oven to cycle 3 times or until the technician is satisfied with the proper operation of the oven.

BLOWER WHEEL REPLACEMENT:

The blower wheel is located inside the oven cavity. To replace the blower wheel, remove the baffle at the back of the oven. This will expose the blower wheel to plain view and allow easy access. Loosen the two (2) set screws holding the blower wheel onto the motor shaft. Using a three-finger blower wheel puller, grasp the puller ring with all three fingers and tighten the puller until the blower wheel hub clears the motor shaft. Place new blower wheel on the motor shaft and position exactly 5/8” from the oven back motor plate. Tighten the set screw positioned over the flat on the motor shaft. Spin the fan to make sure it spins straight. Tighten the second set screw and re-tighten the first set screw. Replace the baffle. The oven is now ready to re-start.

MAINTENANCE AND TROUBLESHOOTING CONT'D

MOTOR REPLACEMENT:

The motor is located inside the oven cavity. To replace the motor, remove the baffle at the back of the oven. This will expose the blower wheel and motor shaft to plain view and allow easy access. Remove the blower wheel as described in "BLOWER WHEEL REPLACEMENT". Next, remove the bolts holding the motor plate to the back wall of the oven cavity. Gently pull the motor forward and lay on the bottom of the oven cavity. Mark the wires so they can be placed on the same terminals of the new motor. Remove the motor wires. Remove the motor from the oven. Remove the motor mounting bolts, remove the old motor and replace with the new one. Reverse the above steps to remount the motor and see "BLOWER WHEEL REPLACEMENT" for proper re-installation of the blower wheel.

TRANSFORMER REPLACEMENT:

Pull out control panel as previously outlined. Mark the wires attached to the transformer. Remove the wires. Remove the screws holding the transformer to the control panel. Install the new transformer. Reconnect the wires making sure they are attached to the same terminals as on the original transformer. Reinstall the control panel, restore power to the oven. The oven is now ready for normal operation.

MICROSWITCH REPLACEMENT:

Open the oven doors and remove the screws from the microswitch cover located below the doors. Remove the microswitch cover. Remove the two (2) small screws (6/32) holding the microswitch to its' mount. Mark the wires attached to the microswitch, then remove the wires. Attach the wires to the new microswitch. Mount the microswitch with the two 6/32 screws. Adjust the microswitch arm for proper switch actuation. Replace cover and restart oven.

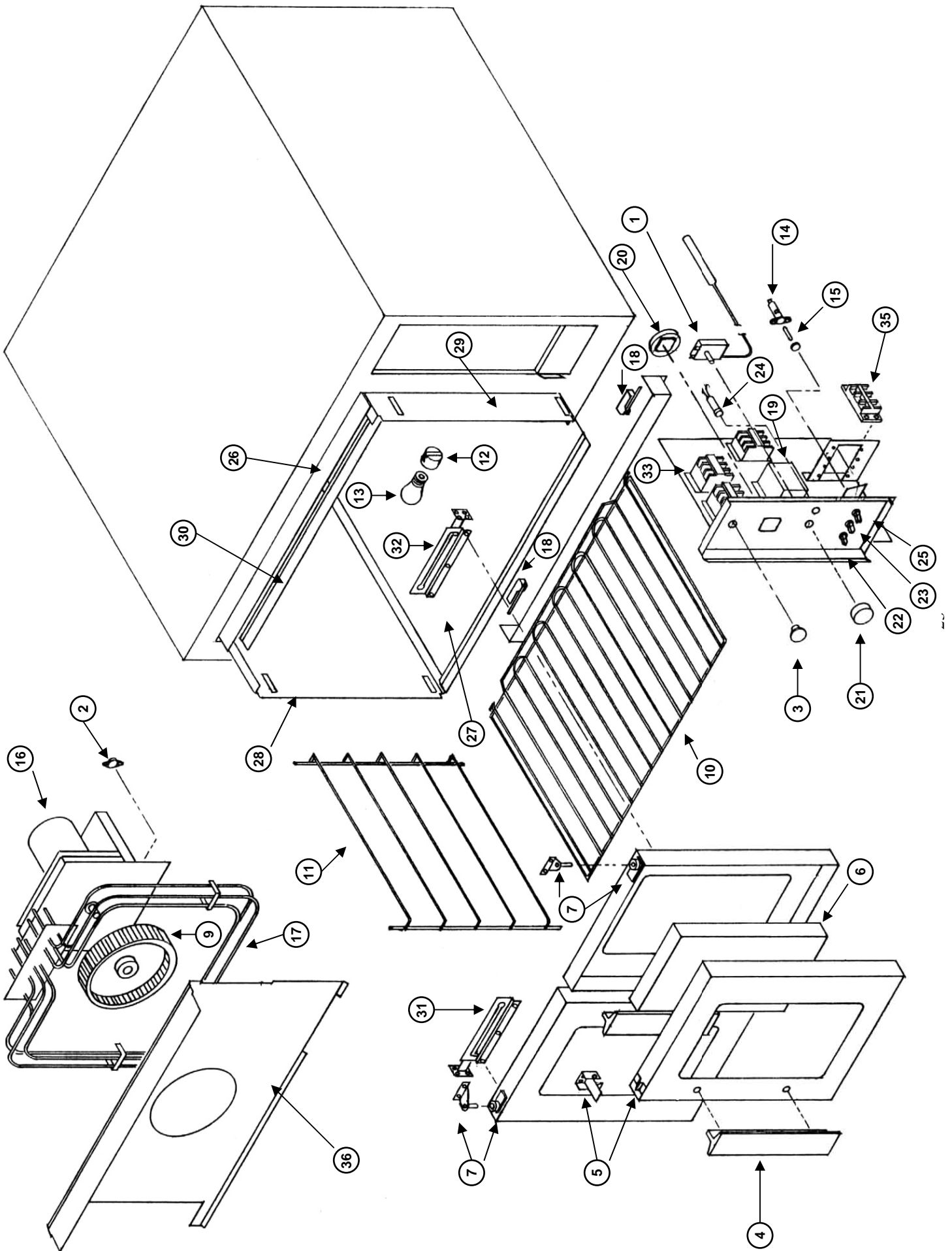

Item #	Description	Lang Part #	Vendor	Vendor #
1	Thermostat	30402-27	Robertshaw Youngswood, PA	KXP-356-48
2	Thermostat, Safety	30401-09	Elmwood Pawtucket, RI	345-0RC-174-0067
3	Knob, Damper	70701-25	Aimsco Seattle, WA	DK-49-REID
4	Handle, Door	70603-20	Lang Mfg Everett, WA	70603-20
5	Latch, Marine Door	ECO-762	Lang Mfg Everett, WA	ECO-762
6	Window, Door	71301-04	Mills Products Farmington, MI	1001453
7	Door Hinge Set, LH and RH	60102-369	Lang Mfg Everett, WA	60101-369
9	Blower Wheel	71500-05	Revcor Carperntersville, IL	1-8149
10	Rack, Deep, ECO-6M & ECO-8M	50200-31	Lang Mfg Everett, WA	50200-31
	Rack, Std., ECO-7M & ECO-9M	50200-20	Lang Mfg Everett, WA	50200-20
11	Rack Slide, ECO-6M & ECO-8M	50200-33	Lang Mfg Everett, WA	50200-33
	Rack Slide, ECO-7M & ECO-9M	50200-32	Lang Mfg Everett, WA	50200-32
12	Socket, Light	31602-04	Lang Mfg Everett, WA	31602-04
13	Lamp, Light	31603-04	Litemor Seattle, WA	1139750A/250V
14	Holder, fuse	30901-08	H.D. Campbell Seattle, WA	HPF-EE Bussman
15	Fuse	30900-10	H.D. Campbell Seattle, WA	SC-15
16	Motor, 440 VAC, 2 speed	30200-16	Leeson Electric Milwaukee, WI	101354.00
17	Element, 440 VAC	11090-25	Caloritech, Inc. Buffalo, NY	IXI-11090-25
18	Microswitch, Door	30301-02	Unimax Boston, MA	HL2KJC3T055C
19	Transformer, 480/240 VAC	31400-04	Argo International New York, NY	HD/2221109T00
20	Timer, Mechanical	30801-03	M.H. Rhodes Chicago, IL	22007
21	Knob, Thermostat	70701-19	Lang Mfg Everett, WA	70701-19
22	Switch, Toggle	30303-06	Carlingswitch Inc. Plainsville, CT	2GL231-78-XLN2
23	Switch, Toggle	30303-06	Carlingswitch Inc. Plainsville, CT	2GL231-78-XLN2
24	Pilot Light, 250 VAC	31601-01	Indicator Lites Chicago, IL	10422250012221
25	Switch, Toggle	30303-06	Carlingswitch Inc. Plainsville, CT	2GL231-78-XLN2

26	S/S Liner, Top ECO-6M & ECO-8M	ECO-750	Lang Mfg Everett, WA	ECO-750
	S/S Liner, Top ECO-7M & ECO-9M	ECO-751	Lang Mfg Everett, WA	ECO-751
27	S/S Liner, Bottom ECO-6M & ECO-8M	ECO-752	Lang Mfg Everett, WA	ECO-752
	S/S Liner, Bottom ECO-7M & ECO-9M	ECO-753	Lang Mfg Everett, WA	ECO-753
28	S/S Liner, Left ECO-6M & ECO-8M	ECO-754	Lang Mfg Everett, WA	ECO-754
	S/S Liner, Left ECO-7M & ECO-9M	ECO-755	Lang Mfg Everett, WA	ECO-755
29	S/S Liner, Right ECO-6M & ECO-8M	ECO-756-01	Lang Mfg Everett, WA	ECO-756-01
	S/S Liner, Right ECO-7M & ECO-9M	ECO-757-01	Lang Mfg Everett, WA	ECO-757-01
30	S/S Liner, End Cover Bottom	ECO-758	Lang Mfg Everett, WA	ECO-758
	S/S Liner, End Cover Top	ECO-758-1	Lang Mfg Everett, WA	ECO-758-1
31	Door Stop Assy, Left Hand	50301-50	Lang Mfg Everett, WA	50301-50
32	Door Stop Assy, Right Hand	50301-88	Lang Mfg Everett, WA	50301-88
33	Contacto, Element	30700-03	Products Unlimited Chicago, IL	3100-30U9198CY
34	Contacto, 2 Speed Motor	30705-01	Products Unlimited Chicago, IL	3120-30K8198Q
35	Terminal Block, 3 Pole 95 Amp	30500-09	All-west Fasteners Seattle, WA	14002-3A
36	Rear Baffle Assembly	ECO-351	Lang Mfg Everett, WA	ECO-351
	Knob, Timer	70701-55	Lang Mfg Everett, WA	70701-55
	Lamp, Lens	31604-01	VWR Scientific Brisbane, CA	66110-065
	Lamp, Lens Gasket	31604-02	Atlas Supply Seattle, WA	31604-02
	Light Ring	50301-21	Lang Mfg Everett, WA	50301-21
	Wing Nut	20304-01	Lang Mfg Everett, WA	20304-01
	Capillary Tube Holder	ECO-276	Lang Mfg Everett, WA	ECO-276

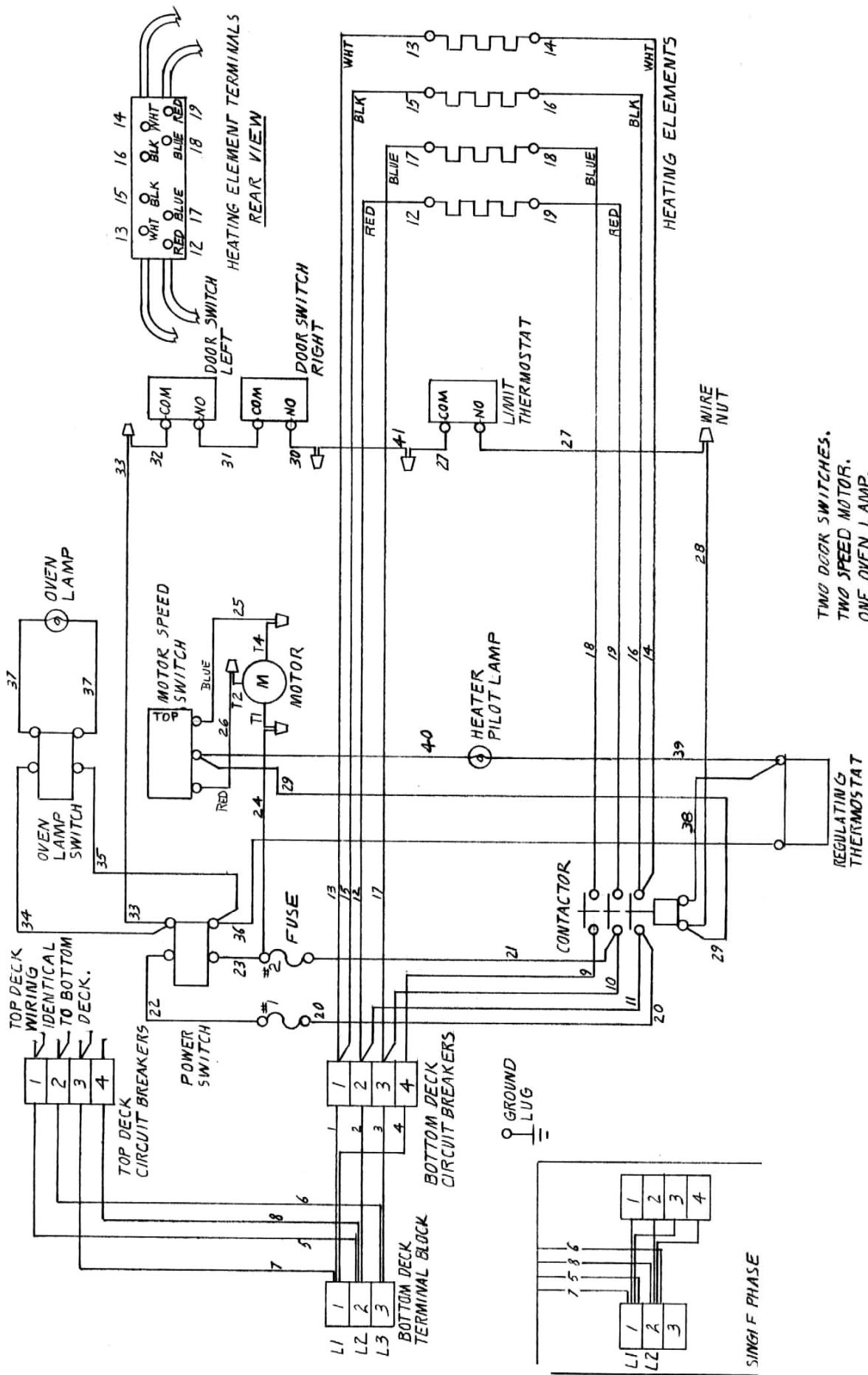

TWO DOOR SWITCHES.
TWO SPEED MOTOR.
ONE OVEN LAMP.

