

Lang[®]

SHIPBOARD ELECTRIC CONVECTION OVEN

ECOD-AT, ECODL-AT
ECOF-AT, ECOFL-AT

Installation and Operation Instructions

2M-W483 Rev. E 3/18/13



ECOF-AT



SAFETY SYMBOL



These symbols are intended to alert the user to the presence of important operating and maintenance instructions in the manual accompanying the appliance.

FOR YOUR SAFETY

DO NOT STORE OR USE GASOLINE OR OTHER FLAMMABLE VAPORS AND LIQUIDS IN THE VICINITY OF THIS OR ANY OTHER APPLIANCE.

POST IN PROMINENT LOCATION

INSTRUCTIONS TO BE FOLLOWED IN THE EVENT USER SMELLS GAS. THIS INFORMATION SHALL BE OBTAINED BY CONSULTING YOUR LOCAL GAS SUPPLIER. AS A MINIMUM, TURN OFF THE GAS AND CALL YOUR GAS COMPANY AND YOUR AUTHORIZED SERVICE AGENT. EVACUATE ALL PERSONNEL FROM THE AREA.

WARNING

IMPROPER INSTALLATION, ADJUSTMENT, ALTERATION, SERVICE OR MAINTENANCE CAN CAUSE PROPERTY DAMAGE, INJURY OR DEATH. READ THE INSTALLATION, OPERATION & MAINTENANCE INSTRUCTIONS THOROUGHLY BEFORE INSTALLING OR SERVICING THIS EQUIPMENT.



WARNING
RISK OF FIRE OR ELECTRIC SHOCK
DO NOT OPEN



WARNING, TO REDUCE THE RISK OF ELECTRICAL SHOCK, DO NOT REMOVE CONTROL PANEL. NO USER-SERVICABLE PARTS INSIDE. REPAIRS SHOULD BE DONE BY AUTHORIZED SERVICE PERSONNEL ONLY.

NOTICE

Using any part other than genuine Lang factory supplied parts relieves the manufacturer of all liability.

Lang reserves the right to change specifications and product design without notice. Such revisions do not entitle the buyer to corresponding changes, improvements, additions or replacements for previously purchased equipment.

Due to periodic changes in designs, methods, procedures, policies and regulations, the specifications contained in this sheet are subject to change without notice. While Lang exercises good faith efforts to provide information that is accurate, we are not responsible for errors or omissions in information provided or conclusions reached as a result of using the specifications. By using the information provided, the user assumes all risks in connection with such use.

MAINTENANCE AND REPAIRS

Contact your local dealer for service or required maintenance. Please record the model number, serial number, voltage and purchase & Installation Information in the area below and have it ready when you call to ensure a faster service.

Model No.: _____

Purchased From: _____

Serial No.: _____

Location: _____

Voltage: _____

Purchase Date: _____

1-Phase or 3 Phase: _____

Installed Date: _____

Table of Contents

Chapter.....	Page
1. Table of Contents	3
2. List of Illustrations	3
3. Specifications	3
4. Equipment Description	4
5. Installation.....	5
6. Operation	7
7. Maintenance & Troubleshooting Procedures	8
8. Parts List.....	15, 17, 19, 21, 23

List of Illustrations

Fig#	Title of Illustration	Page #
1.	Picture of Oven	Cover
2.	Leg Installation	6
3.	Stacking Instructions.....	6
4.	Wiring Diagram 208/240 VAC.....	11
5.	Wiring Diagram 440 VAC	12
6.	Exploded View	14, 16, 18, 20, 22

NOTICE: Service on this, or any other, LANG appliance must be performed by qualified personnel only. Consult your LANG authorized service agent directory or call the factory at 314-678-6315, or www.langworld.com for the service agent nearest you.

SPECIFICATIONS:

Lang Model	Previous Model	Height x Width x Depth	Clearance from combustible surface	Weight		Freight Class
				Actual	Shipping	
ECOD-AT	ECO-6M	25.0" x 38.0" x 45.2" 635mm x 966mm x 1148mm	Side: 6" (153mm) Back: 6" (153mm) Floor: 6" (153mm)	380 lbs. 173 kg	430 lbs. 195 kg	70
ECOF-AT	ECO-7M	25.0" x 38.0" x 38.2" 635mm x 966mm x 970mm		360 lbs. 164 kg	410 lbs. 186 kg	
ECOD-AT ECODL-AT	ECO-8M	50.0" x 38.0" x 45.2" 1270mm x 966mm x 1148mm		820 lbs. 373 kg	870 lbs. 395 kg	
ECOF-AT ECOFL-AT	ECO-9M	50.0" x 38.0" x 38.2" 1270mm x 966mm x 970mm		780 lbs. 355 kg	830 lbs. 377 kg	

Lang Model	Previous Model	Volts AC - Hz	Total kW	L1	L2	L3	Amps - 1Ph
Single Stack ECOD-AT ECOF-AT	ECO-6M ECO-7M	208 - 50/60	11.5	36	36	23	55.3
		240 - 50/60		28	28	26.5	48
		380 - 50		20	20	12.5	N/A
		440 - 50/60		17	17	11	N/A
		480 - 50/60		16	16	10	N/A
Double Stack ECOD-AT, ECODL-AT ECOF-AT, ECOFL-AT	ECO-8M ECO-9M	208 - 50/60	23	59	72	59	111
		240 - 50/60		55	56	55	96
		380 - 50		30	31.5	30	N/A
		440 - 50/60		28	34	28	N/A
		480 - 50/60		26	32	26	N/A

EQUIPMENT DESCRIPTION

INTRODUCTION

This manual contains the necessary information to install, operate, maintain, and service the Lang model ECO convection ovens.

Replacement parts should be genuine Lang parts. Failure to use genuine Lang replacement parts may result in malfunction of the appliance or possible injury to the contractor or service technician.

PURPOSE AND FUNCTION

Convection ovens constantly circulate air over the product. This removes a layer of moisture and cool air from around the product. This allows heat to penetrate the product more quickly. Cooking times are shortened and cooking temperatures are reduced.

CAPABILITIES

This convection oven is suitable for cooking all types of products requiring baking or roasting.

ENVIRONMENTAL REQUIREMENTS

The following minimum spacing from combustible surfaces must be maintained: Sides – 2 inches, Back – 2 inches

ITEMS FURNISHED (Listed by Model Number)

SINGLE STACKED UNITS

ECOD-AT

ECO-6 or ECO-6M (Previous Model)

- 1 ea. Oven, Type I, Size 2
- 4 ea. Legs
- 16 ea. 3/8 – 16 x 5/8 Bolts (For mounting legs)
- 16 ea. 3/8 – 16 Hex Nuts (For mounting legs)
- 32 ea. Washers (For mounting legs)
- 2 ea. Rack Slides, Extra Deep
- 5 ea. Racks, Extra Deep
- 2 ea. Manuals, Technical

ECOD-AT or ECOF-AT

ECO-7 or ECO-7M (Previous Model)

- 1 ea. Oven, Type I, Size 1
- 4 ea. Legs
- 16 ea. 3/8 – 16 x 5/8 Bolts (For mounting legs)
- 16 ea. 3/8 – 16 Hex Nuts (For mounting legs)
- 32 ea. Washers (For mounting legs)
- 2 ea. Rack Slides, Standard Depth
- 5 ea. Racks, Standard Depth
- 2 ea. Manuals, Technical

DOUBLE STACKED UNITS

ECOD-AT, ECODL-AT or ECOF-AT, ECOFL-AT

ECO-8 or ECO-8M (Previous Model)

- 2 ea. Oven, Type II, Size 2
- 4 ea. Legs
- 16 ea. 3/8 – 16 x 5/8 Bolts (For mounting legs)
- 16 ea. 3/8 – 16 Hex Nuts (For mounting legs)
- 32 ea. Washers (For mounting legs)
- 4 ea. Rack Slides, Extra Deep
- 10 ea. Racks, Extra Deep
- 2 ea. Manuals, Technical
- 1 ea. Stacking Kit

ECOD-AT, ECODL-AT or ECOF-AT, ECOFL-AT

ECO-9 or ECO-9M (Previous Model)

- 2 ea. Oven, Type II, Size 1
- 4 ea. Legs
- 16 ea. 3/8 – 16 x 5/8 Bolts (For mounting legs)
- 16 ea. 3/8 – 16 Hex Nuts (For mounting legs)
- 32 ea. Washers (For mounting legs)
- 4 ea. Rack Slides, Standard Depth
- 10 ea. Racks, Standard Depth
- 2 ea. Manuals, Technical
- 1 ea. Stacking Kit

ITEMS REQUIRED

An adequate supply of wire suitable for the loads and application specified on the data sheet must be provided. The data sheet is on Page 4 of this manual.

TOOLS AND TEST EQUIPMENT REQUIRED

For Installation:

- 1 set – Open End Wrenches
- 1 – Flat Blade Screwdriver
- 1 – Phillips Screwdriver
- 1 – Wire Cutter/Stripper
- 1 – AMP Probe
- 1 – Voltmeter
- 1 – Drill
- 4 – #27 Drill Bits

For Service: All of the above plus –

- 1 – Needle Nose Pliers
- 1 – Crimping Pliers
- 1 – Allen Wrench Set
- 1 – Temperature Meter
- 1 – Very Small Flat Blade Screwdriver
- 1 – #10 Square Drive Screwdriver

INSTALLATION



THE OVEN IS EXTREMELY HEAVY. FOR SAFE HANDLING, INSTALLER SHOULD OBTAIN HELP AS NEEDED, OR EMPLOY APPROPRIATE MATERIALS HANDLING EQUIPMENT (SUCH AS A FORKLIFT, DOLLY, OR PALLET JACK) TO REMOVE THE UNIT FROM THE SKID AND MOVE IT TO THE PLACE OF INSTALLATION.



ANY STAND, COUNTER OR OTHER DEVICE ON WHICH OVEN WILL BE LOCATED MUST BE DESIGNED TO SUPPORT THE WEIGHT OF THE OVEN(S).



THIS APPLIANCE MUST BE GROUNDED AT THE TERMINAL PROVIDED. FAILURE TO GROUND THE APPLIANCE COULD RESULT IN ELECTROCUTION AND DEATH.



INSTALLATION OF THE UNIT MUST BE DONE BY PERSONNEL QUALIFIED TO WORK WITH ELECTRICITY AND PLUMBING. IMPROPER INSTALLATION CAN CAUSE INJURY TO PERSONNEL AND/OR DAMAGE TO EQUIPMENT. UNIT MUST BE INSTALLED IN ACCORDANCE WITH ALL APPLICABLE CODES.

NOTICE: The data plate is located on the door of the oven. The oven voltage, wattage, serial number, wire size, and clearance specifications are on the data plate. This information should be carefully read and understood before proceeding with the installation.

NOTICE: The installation of any components such as a vent hood, grease extractors, fire extinguisher systems, must conform to their applicable National, State and locally recognized installation standards.

INSTALLATION

INSPECTION AND INSTALLATION

Upon receipt of the oven(s) any damage should be noted on the Bill of Lading and countersigned by the carrier. If concealed damage is discovered the carrier should be notified. All claims must be filed with the carrier.

Move the crate(s) containing the oven(s) as close to the place of installation as possible before removing the protective crating. Uncrate the oven(s) and move them as close as practical to the final installation site.

Bolt the legs to the bottom oven, (See figure #2). Use the 3/8 – 16 x 5/8 Bolts, Hex Nuts and Washers provided. There are pre-punched holes provided in the legs and oven bottom to aid in leg installation. Now the oven can be set upright in or near its final position.

SINGLE OVENS:

Connect power through the knockout on the bottom of the unit.

The oven can be placed in its final position and leveled. The oven is ready for initial start-up procedures now. (See page 7)

STACKED OVENS:

Be careful to route the power supply wire between the two ovens using the holes provided. Do not pinch or cut the supply wires when stacking the ovens. Use the stacking kit provided to secure the top oven to the bottom oven.

The stacking kit contains four (4) identical corner braces, one brace goes on each corner. Drill pilot holes for the mounting screws using the pre-punched holes as a guide. Secure the top oven to the bottom oven with the sheet metal screws provided. (See figure #3)

Connect the power supply leads from the top oven to the power supply leads of the bottom oven and incoming power per the wiring diagram on Page 11 or 12.

Now the bottom oven can be connected to the incoming power supply through the knockout provided in the bottom of the oven. Be sure the power supply voltage matches the voltage specified on the nameplate located on the front of the oven! Then the oven can be placed in its final position and leveled. The oven is ready for initial start-up procedures now. See page 7.

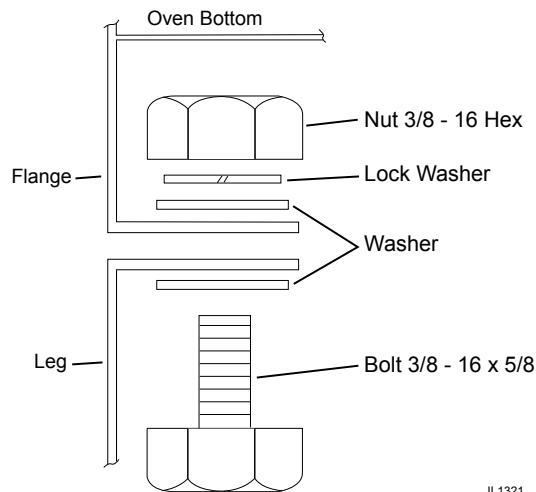

IL1321

Figure 2, Bolting Legs to bottom oven

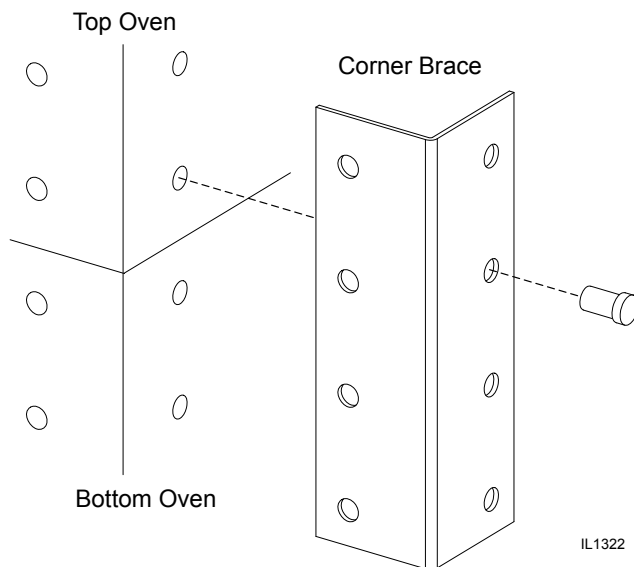

IL1322

Figure 3, Securing the top & bottom ovens together.

OPERATING INSTRUCTIONS

NOTICE: During the first few hours of operation you may notice a small amount of smoke coming off the oven, and a faint odor from the smoke. This is normal for a new oven and will disappear after the first few hours of use.



ALWAYS KEEP THE AREA NEAR THE APPLIANCE FREE FROM COMBUSTIBLE MATERIALS.



KEEP FLOOR IN FRONT OF EQUIPMENT CLEAN AND DRY. IF SPILLS OCCUR, CLEAN IMMEDIATELY, TO AVOID THE DANGER OF SLIPS OR FALLS.

Each oven has the following controls:

Vent – Pull to Open, Push to close.

Timer – Adjust to desired setting.

Temperature – Turn to desired cooking temperature.

Power Switch – Pull up to turn oven ON, push down to turn oven OFF.

Light Switch – Pull up to turn oven light ON, release and oven light goes out automatically.

Motor Speed Switch – Pull up for High Speed, push down for low speed.

INITIAL START-UP

Set oven(s) at 350°F and allow oven to operate empty for 3 hours, prior to initial use.

NORMAL OPERATION

Turn the Power Switch On, turn to the desired temperature and select motor speed. (*Hi or Low*)

MAINTENANCE

Wash the stainless interior & exterior often with a solution of hot water and mild detergent to prevent grease build-up and preserve the oven's appearance. The oven racks, slides and stainless steel oven liners are removable for easier cleaning of the oven interior.

NOTE: Wipe up spillage as soon as possible. Never use scouring powder. It is difficult to remove completely and a residue build-up can damage the oven.



WARNING

KEEP WATER AND SOLUTIONS OUT OF CONTROLS. NEVER SPRAY OR HOSE CONTROL CONSOLE, ELECTRICAL CONNECTIONS, ETC.



CAUTION

MOST CLEANERS ARE HARMFUL TO THE SKIN, EYES, MUCOUS MEMBRANES AND CLOTHING. PRECAUTIONS SHOULD BE TAKEN TO WEAR RUBBER GLOVES, GOGGLES OR FACE SHIELD AND PROTECTIVE CLOTHING. CAREFULLY READ THE WARNING AND FOLLOW THE DIRECTIONS ON THE LABEL OF THE CLEANER TO BE USED.

NOTICE:

Service on this, or any other, LANG appliance must be performed by qualified personnel only. Consult your authorized service station directory or call the factory at 314-678-6315, or www.langworld.com For the service station nearest you.



WARNING

BOTH HIGH AND LOW VOLTAGES ARE PRESENT INSIDE THIS APPLIANCE WHEN THE UNIT IS PLUGGED/WIRED INTO A LIVE RECEPTACLE. BEFORE REPLACING ANY PARTS, DISCONNECT THE UNIT FROM THE ELECTRIC POWER SUPPLY.



CAUTION

USE OF ANY REPLACEMENT PARTS OTHER THAN THOSE SUPPLIED BY LANG OR THEIR AUTHORIZED DISTRIBUTORS CAN CAUSE BODILY INJURY TO THE OPERATOR AND DAMAGE TO THE EQUIPMENT AND WILL VOID ALL WARRANTIES.

TROUBLESHOOTING GUIDE

SYMPTOM	PROBLEM	REMEDY
Oven will not turn on	Internal Circuit Breakers Off	Turn on
	Power supply circuit breakers off	Turn on
	Improperly Phased	Phase per wiring diagram
	Fuse Open	Change fuses
Power Supply Circuit Breakers Trip	Supply circuit breakers of insufficient size	Install proper size breakers
	Supply voltage & oven voltage do not match	Change voltage to match oven
Internal circuit breakers trip	Supply voltage & oven voltage do not match	Change voltage to match oven
Oven takes to long to bake and will not maintain temperature	Improperly Phased	Phase oven to match power supply per wiring diagram

MAINTENANCE and TROUBLESHOOTING CONT'D

PERFORMANCE AND INSPECTION

A periodic check of thermostat calibration should be performed. To check oven calibration attach a thermocouple to the mid-point of the thermostat bulb in the oven cavity. Turn the temperature dial to 350°F and turn the oven ON. Wait approximately 20 minutes until the oven temperature has stabilized. If the average of the ON and OFF thermostat readings is within 10°F of 350°F the oven is in calibration. If not, remove the temperature knob and turn the small screw in the middle until oven is in calibration. Replace the knob and the oven is ready for normal operation.

MAJOR COMPONENT DISASSEMBLY, REPAIR, REPLACEMENT & REASSEMBLY

(Refer to figure #4, page 22)

THERMOSTAT, CONTACTORS (RELAYS), SWITCHES

These parts are located behind the control panel assembly on the right hand side of each oven. Remove the screws attaching the control panel to the front of the oven. Slowly pull out the control panel until the component requiring replacement is accessible.

THERMOSTAT REPLACEMENT:

Inside the oven cavity remove the retaining clips holding the thermostat-sensing bulb in place. Feed the bulb through the oven wall into the control panel area. Remove the wires attached to the thermostat terminals. Remember the terminal each wire was on and attach the wires to the same terminal on the new thermostat. Remove the screws holding the old thermostat to the front of the control panel. Discard old thermostat. Mount the new thermostat to the control panel, carefully feed the sensing bulb through the oven wall, and reattach the sensing bulb to the oven side using the retaining clips removed earlier. Close control compartment. Restore power to oven. Refer to the "Performance and Inspection" section to verify proper operation of the new thermostat.

ELEMENT REPLACEMENT:

The element is located inside the oven cavity. To replace the element, remove the baffle at the back of the oven. This will expose the elements to plain view and allow easy access. Remove the element mounting screws located near the top of the oven. Gently, pull the element into the oven cavity. There is enough wire connected to the element to allow easy access to the terminals located behind the element mounting plate. Move each wire from the existing terminal to the corresponding terminal on the new element. **DO NOT** mix up these wires! After all wires are transferred to the new element, feed the wire back through the access hole in the back of the oven and attach the element to the oven wall with the screws removed earlier. Replace the baffle. Refer to the "Initial Start-up" section to restore the oven to proper operation.

CONTACTOR (RELAY), SWITCH REPLACEMENT:

Pull out control panel as previously outlined. Remove the wires from the contactor or switch being changed. Place those wires on the corresponding terminal of the new part. Remove old part and mount new part with wires attached in the spot where the old part used to be. Reinstall the control panel, restore power to the oven. Turn oven on, set thermostat to 200°F and allow oven to cycle 3 times or until the technician is satisfied with the proper operation of the oven.

BLOWER WHEEL REPLACEMENT:

The blower wheel is located inside the oven cavity. To replace the blower wheel, remove the baffle at the back of the oven. This will expose the blower wheel to plain view and allow easy access. Loosen the two (2) set screws holding the blower wheel onto the motor shaft. Using a three-finger blower wheel puller, grasp the puller ring with all three fingers and tighten the puller until the blower wheel hub clears the motor shaft. Place new blower wheel on the motor shaft and position exactly 5/8" from the oven back motor plate. Tighten the set screw positioned over the flat on the motor shaft. Spin the fan to make sure it spins straight. Tighten the second set screw and re-tighten the first set screw. Replace the baffle. The oven is now ready to re-start.

MAINTENANCE and TROUBLESHOOTING CONT'D

MOTOR REPLACEMENT:

The motor is located inside the oven cavity. To replace the motor, remove the baffle at the back of the oven. This will expose the blower wheel and motor shaft to plain view and allow easy access. Remove the blower wheel as described in "**BLOWER WHEEL REPLACEMENT**". Next, remove the bolts holding the motor plate to the back wall of the oven cavity. Gently pull the motor forward and lay on the bottom of the oven cavity. Mark the wires so they can be placed on the same terminals of the new motor. Remove the motor wires. Remove the motor from the oven. Remove the motor mounting bolts, remove the old motor and replace with the new one. Reverse the above steps to remount the motor and see "**BLOWER WHEEL REPLACEMENT**" for proper re-installation of the blower wheel.

TRANSFORMER REPLACEMENT:

Pull out control panel as previously outlined. Mark the wires attached to the transformer. Remove the wires. Remove the screws holding the transformer to the control panel. Install the new transformer. Reconnect the wires making sure they are attached to the same terminals as on the original transformer. Reinstall the control panel, restore power to the oven. The oven is now ready for normal operation.

MICROSWITCH REPLACEMENT:

Open the oven doors and remove the screws from the micro switch cover located below the doors. Remove the micro switch cover. Remove the two (2) small screws (6/32) holding the micro switch to its' mount. Mark the wires attached to the micro switch, then remove the wires. Attach the wires to the new micro switch. Mount the micro switch with the two 6/32 screws. Adjust the micro switch arm for proper switch actuation. Replace cover and restart oven.

Lang® LANG MANUFACTURING INT. INC.
10 SUMNER DRIVE
ST. LOUIS, MO. 63143, USA

THIS DRAWING CONTAINS INFORMATION CONFIDENTIAL TO STARBUCKS, INTL. INC. NO REPRODUCTION OR DISCLOSURE OF ITS CONTENTS IS PERMITTED.

MATERIAL: FINISH

MODEL NO. 2M-61111-30

TITLE: WD ECO MIL 208/240V 1 OR 3 PHASE

DATE: 6/19/2009 SHEET 1 OF 2 REVISIONS

DR: JMM CK. DATE: 6/19/2009

TOLENANCE: UNLESS NOTED: .XXX ± 0.15 ANGLES: ± 1°

REV.	DATE/ECO	DESCRIPTION OF CHANGE	DR
B	6/23/2009 ECO 8289	REINSTATED OBSOLETE PIN OB-61111-30	JMM
C	ECO 8849	WIRE 48 WAS 27	JMM
D	10/16/2012 ECO 12263	ADDED NOTE FOR BLACK LEAD CONNECTIONS.	JMM

	VOLTS	KW	AMPS			
			L1	L2	L3	1 PHASE
1 DECK	208	11.5	36	36	23	55.3
1 DECK	240	11.5	28	28	26	48
2 DECK	208	23.0	59	59	72	111
2 DECK	240	23.0	55	56	55	96

SERVICE CONNECTIONS						
THREE PHASE			SINGLE PHASE			
L1	L2	L3	L1	L2	L3	
1 DECK	1,4	2	3	1,3	2,4	
2 DECK	1,4,7	2,5,8	3,6	1,3,5,7	2,4,6,8	

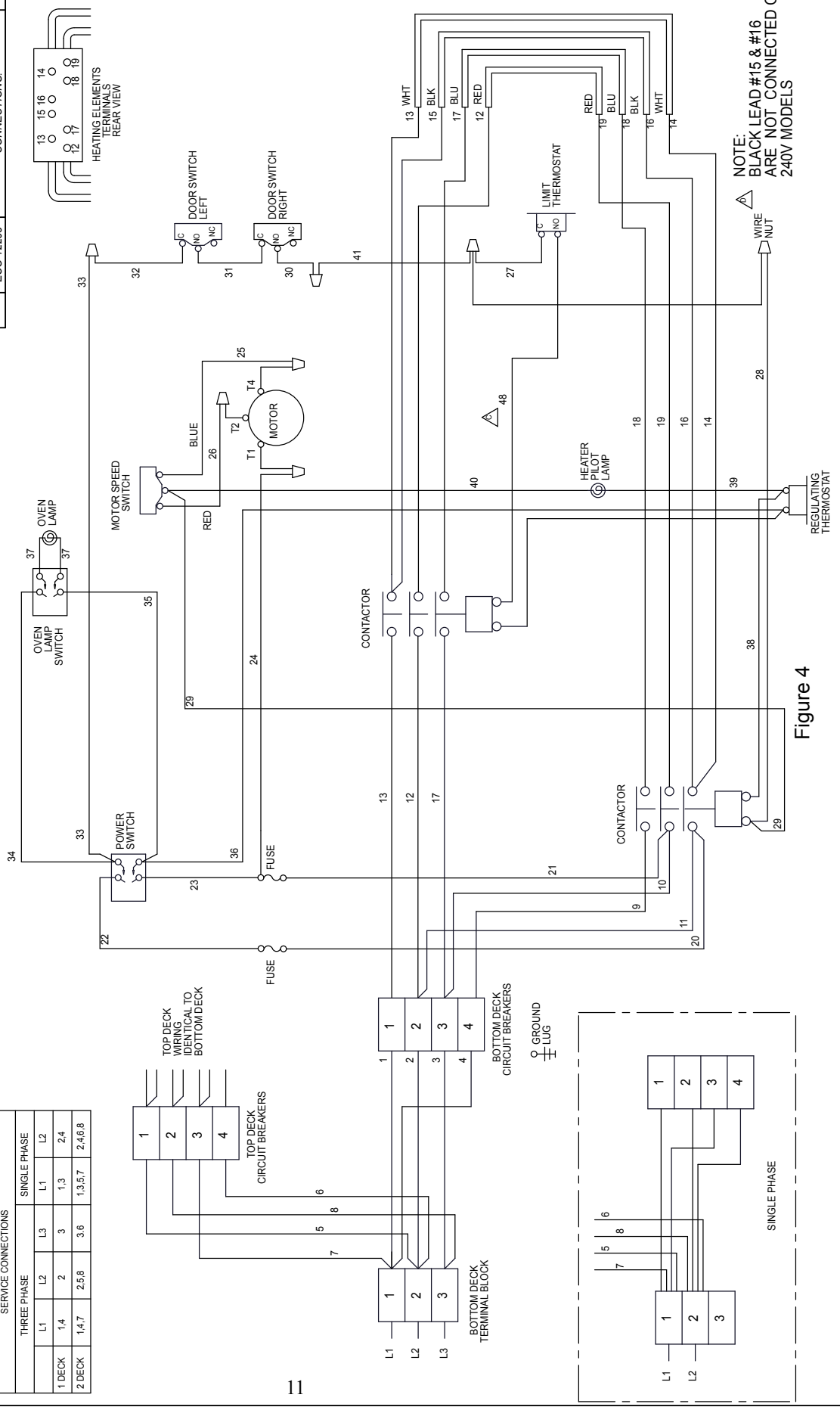

*This page intentionally left blank,
so the following pages face each other.*

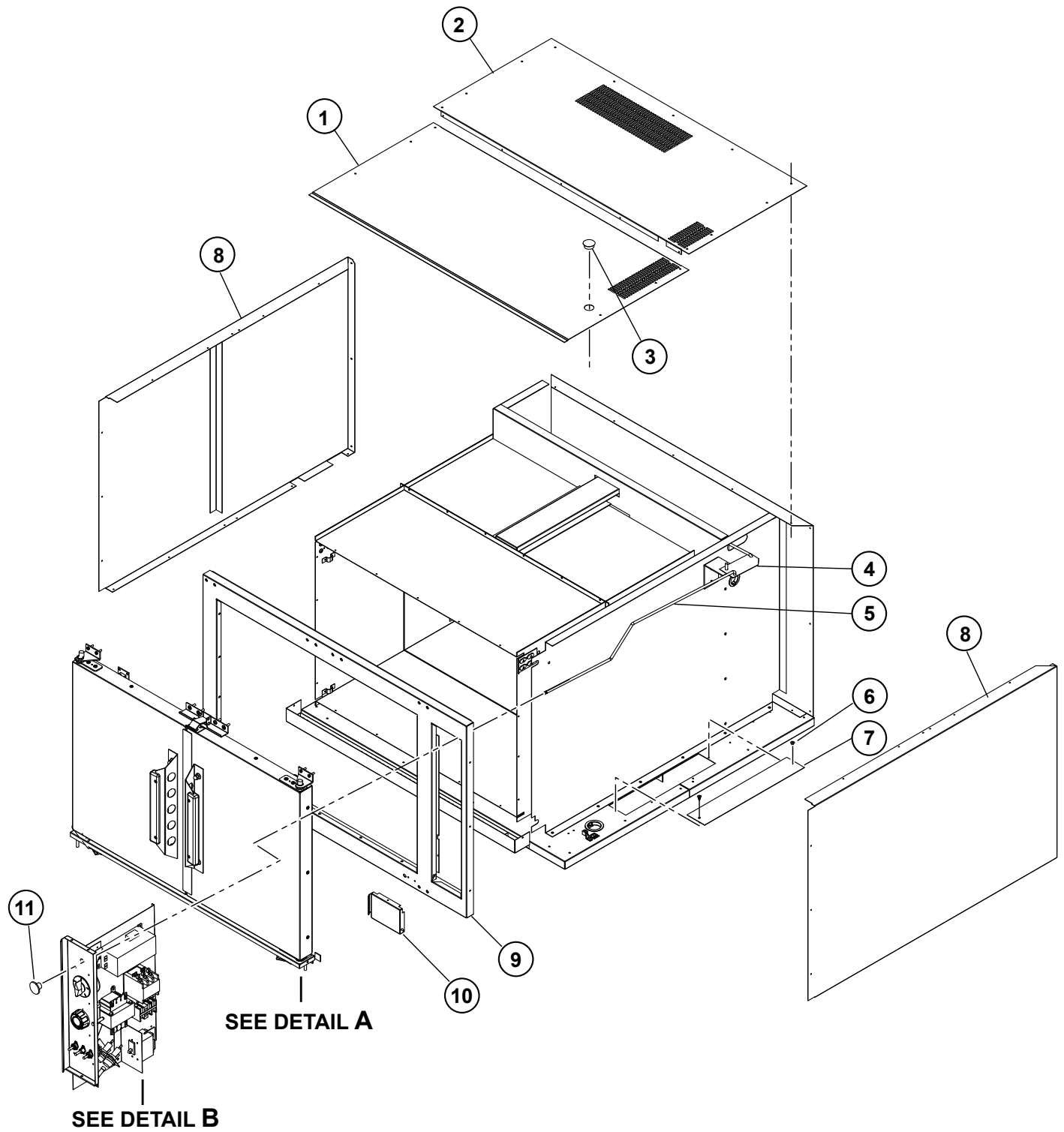

Figure 6a

Model:
 ECOF-AT1M Electric Marine Convection Oven
 ECO-7M Electric Marine Convection Oven

Lang[®]

SK2257

Rev. - 6/12/07

PARTS LIST

March 18, 2013, Rev E

Model No: ECOD-AT, ECODL-AT, ECOF-AT, ECOFL-AT SHIPBOARD ELECTRIC CONVECTION OVEN

Key Number	Part Number	Qty Per	Description
1	Q9-ECO-471	1	TOP-TOP DECK ECOF
	Q9-ECO-472	1	TOP-BOTTOM DECK ECOFL
	Q9-ECO-477	1	TOP-TOP-DECK DEEP OVEN ECOD
	Q9-ECO-478	1	TOP-BOTTOM DECK DEEP ECODL
2	Q9-ECO-471-1	1	TOP FRONT - TOP DECK - HATCHABLE
	Q9-ECO-471-2	1	TOP REAR - TOP DECK - SUB HATCHABLE
3	2P-70901-01	1	PLG BTN BLKPLSTC 1DP-1000 ECOD-AT-440G, ECODL-AT440M, ECOFL-AT208M, ECOFL-AT440M
	2P-70901-01	2	PLG BTN BLKPLSTC 1DP-1000 ECOF-AT-480M, ECOD-AT-480M
4	Q9-ECO-437	1	DAMPER PIVOT ALL
5	Q9-ECO-446	1	DAMPER ROD A ECOF
	Q9-ECO-461	1	DAMPER ROD A - DEEP ECOD
6	2C-20103-02	2	SCRW SM PLT 10 X .5 PHLSL HATCHABLE
7	Q9-ECO-479-1	1	BTM COVER BTM DECK ONLY - HATCHABLE
8	Q9-ECO-177	1	BODY WRAP ASSY ECOF
	Q9-ECO-177-1	1	BODY WRAP DEEP ASSY ECOD
9	Q9-ECO-196-1	1	FRONT ASSY - SUB ALL
10	Q9-ECO-203	1	SWITCH DOOR ASSY ALL
11	2R-70701-25	1	KNOB DAMPER BLACK PLAIN ALL
RACKS			
NI	2B-50200-20	5	RACK ECCO/GCCO OVEN ECOF
NI	2B-50200-31	5	RACK ECO DEEP OVEN ONLY ECOD
NI	2B-50200-32	2	RACK SLIDE 5 POS ECO OVEN ECOF
NI	2B-50200-33	2	RACK SLIDE 5 POS ECO DEEP ECOD

**IMPORTANT: WHEN ORDERING, SPECIFY VOLTAGE OR TYPE GAS DESIRED
INCLUDE MODEL AND SERIAL NUMBER**

PAGE 1
OF 1

Some items are included for illustrative purposes only and in certain instances may not be available.



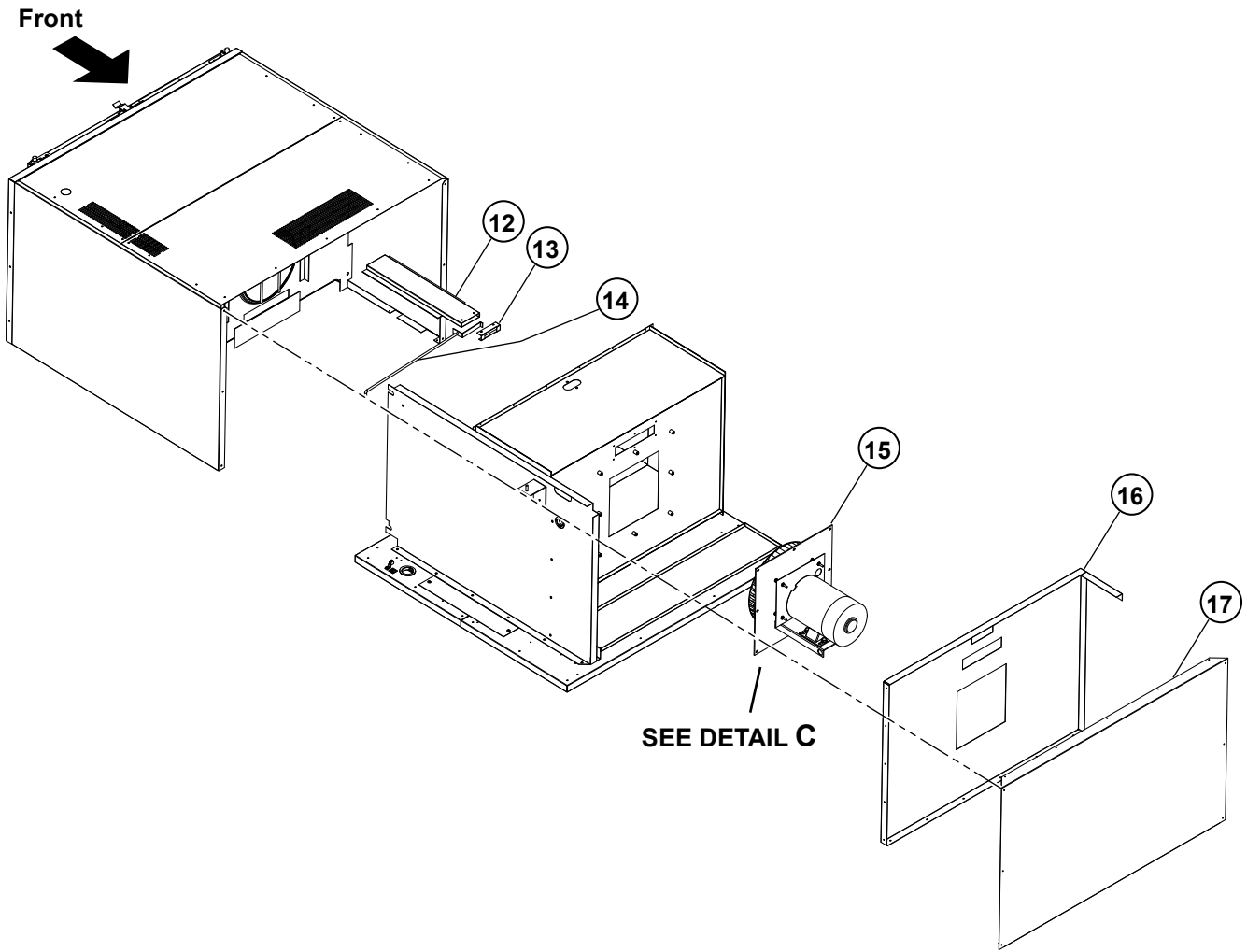

Figure 6b

Model:
 ECOF-AT1M Electric Marine Convection Oven
 ECO-7M Electric Marine Convection Oven

Lang[®]

SK2258

Rev. - 6/12/07

PARTS LIST

March 18, 2013, Rev E

Model No: ECOD-AT, ECODL-AT, ECOF-AT, ECOFL-AT SHIPBOARD ELECTRIC CONVECTION OVEN

Key Number	Part Number	Qty Per	Description
12	Q9-ECO-423		VENTS ASSY ALL
13	Q9-ECO-435		VENT CAP - MILITARY ALL
14	Q9-ECO-449	1	DAMPER ROD B ASSY ALL
15	Q9-ECO-391	1	MOTOR MOUNT ASSY 440/480V 440V/480V
	Q9-ECO-391-1	1	MOTOT MOUNT ASSY 208V 208V
16	Q9-ECO-172	1	REAR FIREWALL ASSY ALL
17	Q9-ECO-184	1	BODY BACK ALL
	ELEMENTS		
NI	2N-11090-18	1	ELMNT ECCO 480V 11KW 480V
NI	2N-11090-30	1	ELE 415 440V11KW 440V, 380V
NI	2N-11090-16	1	ELE ECCO OVN 208/240V 11KW 208/240V

**IMPORTANT: WHEN ORDERING, SPECIFY VOLTAGE OR TYPE GAS DESIRED
INCLUDE MODEL AND SERIAL NUMBER**

PAGE 1
OF 1

Some items are included for illustrative purposes only and in certain instances may not be available.



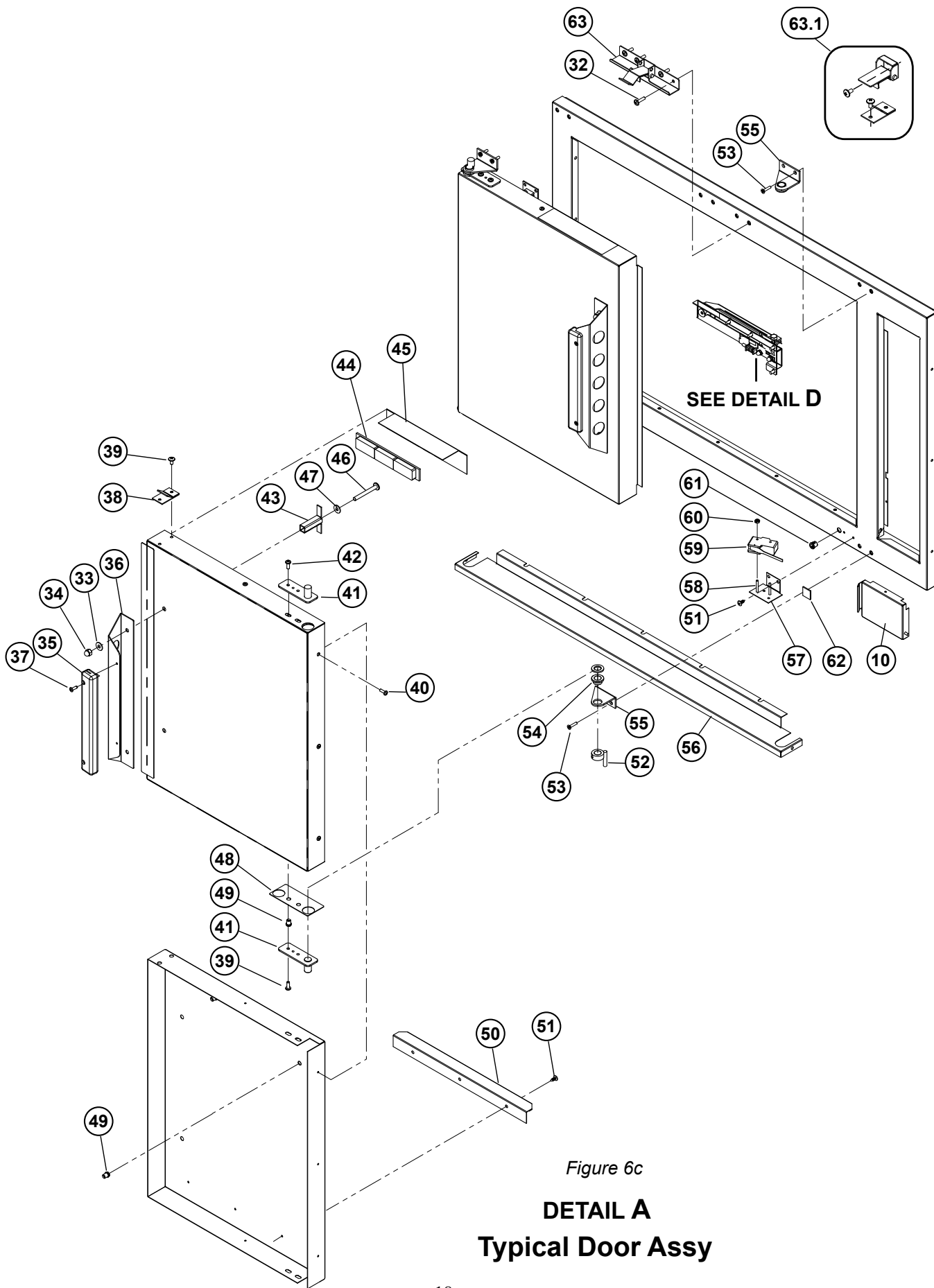

PARTS LIST

March 18, 2013, Rev E

Model No: ECOD-AT, ECODL-AT, ECOF-AT, ECOFL-AT SHIPBOARD ELECTRIC CONVECTION OVEN

Key Number	Part Number	Qty Per	Description	
32	2C-20109-25	4	SCRW S/S 10-32 X 3/4 T/H	ALL
33	2C-20201-07	4	WSHR FLT 1/4 SAE PLTD	ALL
34	2C-20301-29	4	NUT HEX ACORN 1/4-20 S/S	ALL
35	2C-20102-04	4	SCRW PHD ST 8-32X.5 PLTD	ALL
36	Q9-ECO-595	2	ECO DOOR HANDLE	ALL
37	2R-50800-91	2	DOOR HANDLE	ALL
38	Q9-ECO-200-3	1	DOOR CATCH ASSY - SUB	ALL
39	2C-20109-04	2	SCRW THD MS SS 10-32X3/8	ALL
40	2C-20115-01	10	SCRW S/S 8-32X1/2 P/H S/T	ALL
41	Q9-ECO-507	4	HINGE PIN WELD - ECO	ALL
42	2C-20109-15	8	SCRW PHD MS SS 10-32X1/2	ALL
43	Q9-ECO-557	4	HANDLE SPACER	ALL
44	2R-70602-03	2	CATCH DOOR MAGNET 3 PC	ALL
45	Q9-ECO-533	2	MAGNET BACKER	ALL
46	2C-20101-10	4	SCRW THD MS 1/4-20X2 1/4	ALL
47	2C-20201-07	4	WSHR FLT 1/4 SAE PLTD	ALL
48	Q9-ECO-563	4	RETAINER	ALL
49	2C-20306-03	10	AVK CAD 10-32 1ST GRP	ALL
50	Q9-ECO-572	1	RH DOOR VANE ASSY S/S	ALL
50	Q9-ECO-584	1	LH DOOR VANE ASSY S/S	ALL
51	2C-20103-02	AR	SCRW SM PLT 10 X .5 PHLSL	ALL
52	Q9-ECO-777-1	2	SWITCH CAM ASSY - 1/2	ALL
53	2C-20109-30	8	SCRW MS SS 10-32 X .75 PH	ALL
54	2P-70201-19	4	BRNZBRFLN1/2IDX5/8ODX3/8	ALL
55	Q9-ECO-508-1	1	HINGE BOTTOM RH - ECO	ALL
	Q9-ECO-508-2	1	HINGE BOTTOM LH - ECO	ALL
	Q9-ECO-508-3	1	HINGE TOP LH - ECO	ALL
	Q9-ECO-508-4	1	HINGE TOP RH - ECO	ALL
56	Q9-ECO-782	1	SWITCH BOX COVER	ALL
57	Q9-ECO-786	2	SWITCH BRACKET MILITARY	ALL
58	2C-20101-17	4	SCRW RND MS 6-32X1 PLTD	ALL
59	2E-30301-02	2	SWT MICRO #2HLT-5 UNIMAX	ALL
60	2C-20301-10	4	NUT HEX 6-32 PLTD	ALL
61	2K-70801-03	1	SNAP BUSH 3/8 SB375-4 BLK	ALL
62	2C-31901-01	1	CABLE TIE MOUNT	ALL
63	Q9-ECO-200-2	1	DOOR LATCH ASSY -	SUBMARINE
63.1	Y9-50307-24	-	LATCH ASSY - DOOR	MARINE
NI	2H-60106-13	2	INSULATION KIT ECO DOOR	ALL
NI	2Q-71301-04	2	WINDOW ASSY 9-5/8X16-5/8	ALL
NI	Q9-60102-2022	1	DOOR ASSY ECO RIGHT HAND	ALL
NI	Q9-60102-2021	1	DOOR ASSY ECO LEFT HAND	ALL

**IMPORTANT: WHEN ORDERING, SPECIFY VOLTAGE OR TYPE GAS DESIRED
INCLUDE MODEL AND SERIAL NUMBER**

PAGE 1
OF 1

Some items are included for illustrative purposes only and in certain instances may not be available.



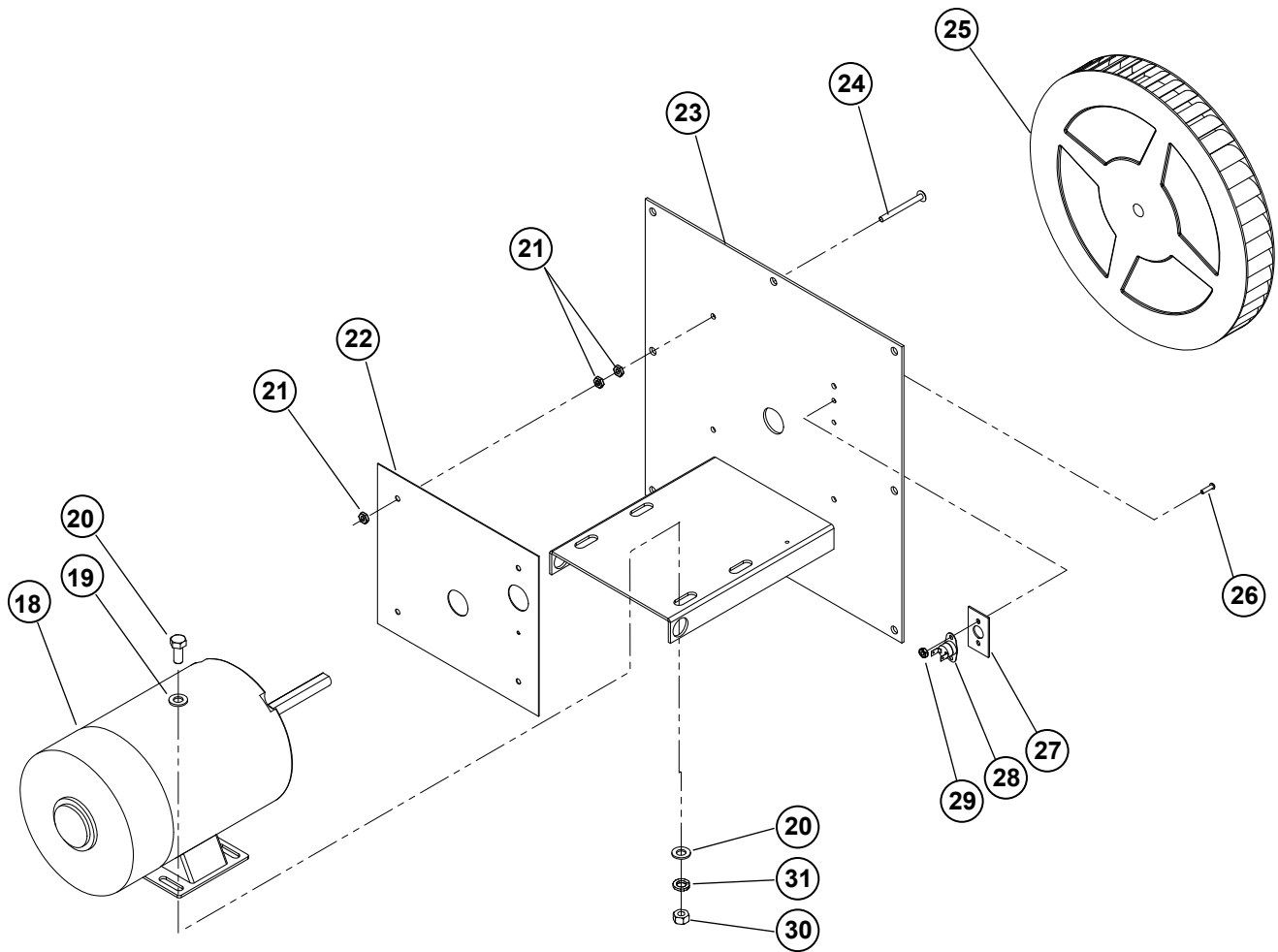

DETAIL C

Motor Mount Assy

SK2259a

Figure 6d

PARTS LIST

March 18, 2013, Rev E

Model No: ECOD-AT, ECODL-AT, ECOF-AT, ECOFL-AT SHIPBOARD ELECTRIC CONVECTION OVEN

Key Number	Part Number	Qty Per	Description
18	2U-30200-16	1	MTR 1/3HP 460V/1/60HZ 2SP 480V
	2U-30200-17	1	MTR 1/3HP208/240V 1PH 2SPD 208V
	2U-30200-60	1	MTR 1/3HP380V1PH50HZ2SP 380V
19	2C-20118-01	4	SCRW CARRAGE PLT 5/16X.75 ALL
20	2C-20202-09	4	WSHR LOCK 3/8 STD SPLIT ALL
21	2C-20301-09	12	NUT HEX 10-24 PLTD ALL
22	Q9-GCCO-167	1	MOTOR SHIELD ALL
23	Q9-60102-37	1	MOTOR MOUNT PLATE ASSY ALL
24	2C-20101-42	4	SCRW THD MS 10-24X2 PLTD ALL
25	2U-71500-05	1	BLOWER WHEEL ECCO/GCCO ALL
26	2C-20101-13	2	SCRW RHD MS 6-32X1/2 PLTD ALL
27	Q9-GCCO-166-2	1	SPACER - SAFETY STAT ALL
28	2T-30401-09	1	STAT FXD 500 DEG OPEN ALL
29	2C-20301-10	2	NUT HEX 6-32 PLTD ALL
30	2C-20301-06	4	NUT HEX 5/16-18 PLTD ALL
31	2C-20202-08	4	WSHR PLT 5/16 LOCK SPLIT ALL

**IMPORTANT: WHEN ORDERING, SPECIFY VOLTAGE OR TYPE GAS DESIRED
INCLUDE MODEL AND SERIAL NUMBER**

PAGE 1
OF 1

Some items are included for illustrative purposes only and in certain instances may not be available.



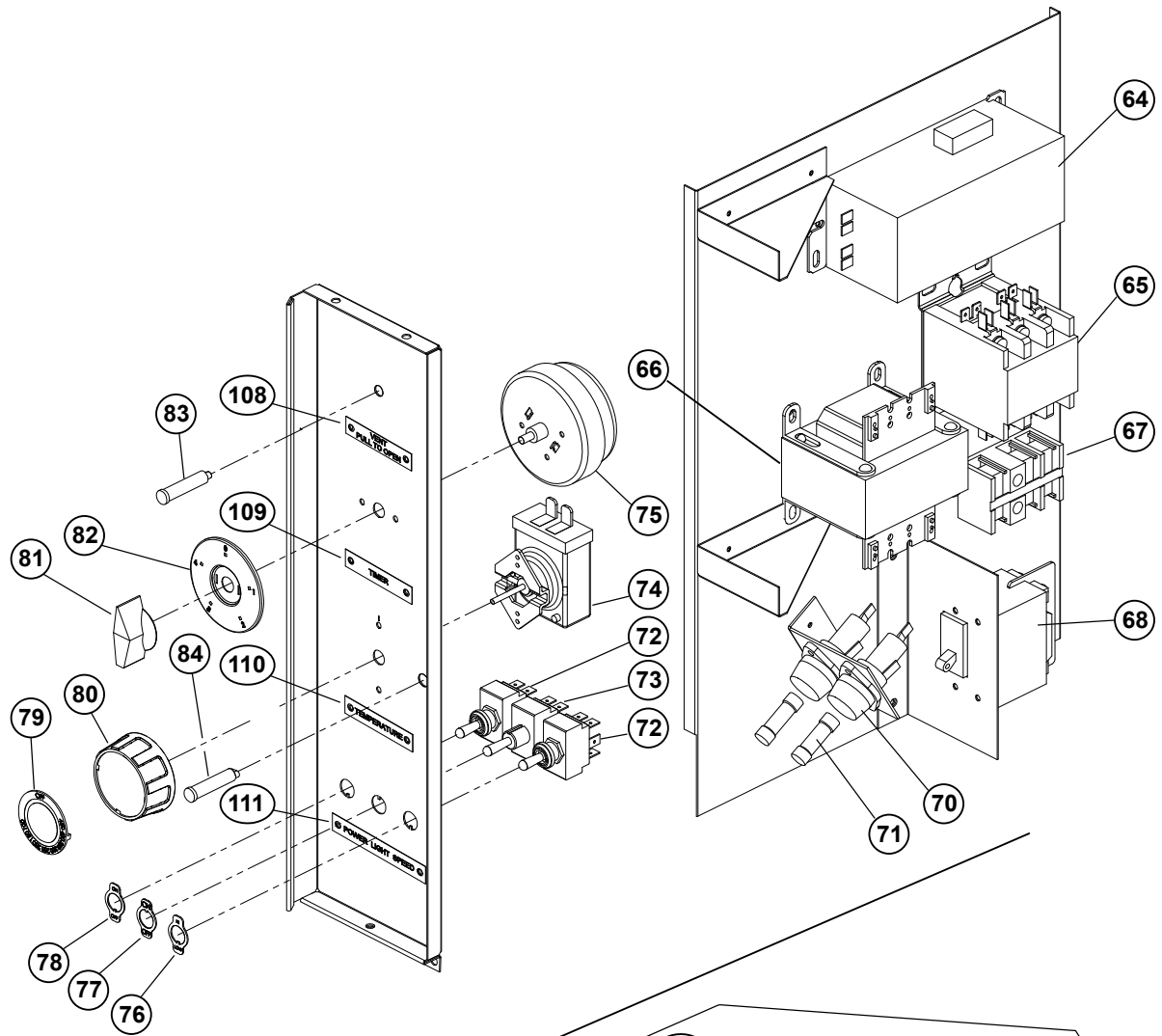

DETAIL B

DETAIL D
 Typical Door Stop Assy
 Figure 6e

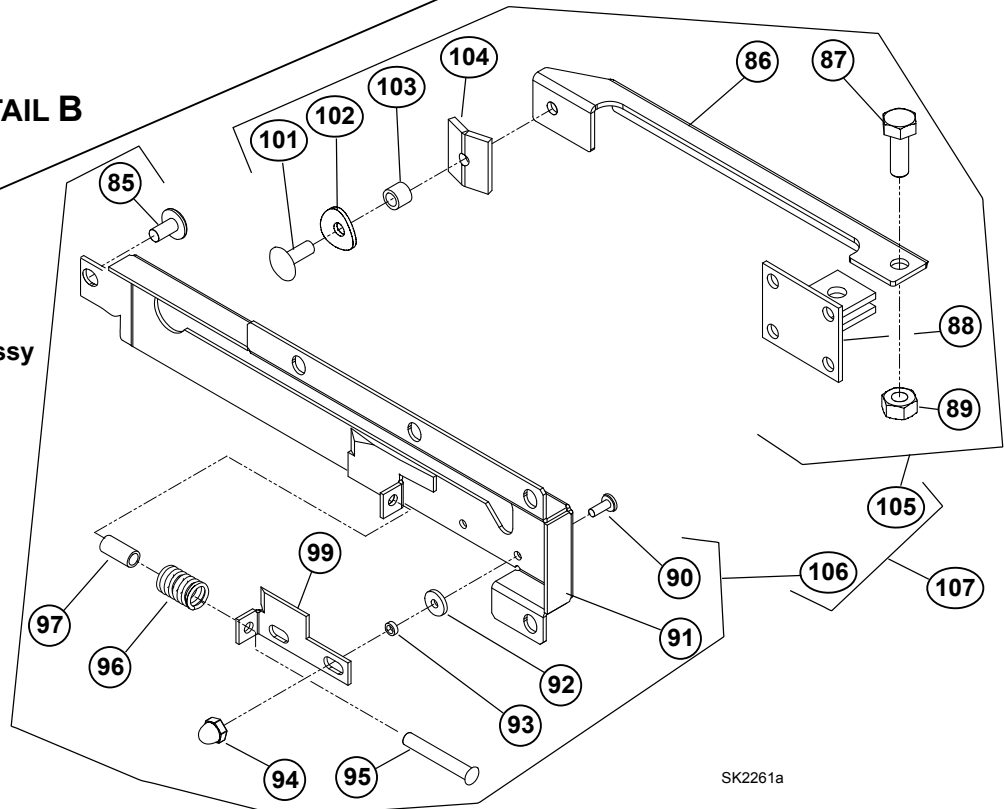

SK2261a

PARTS LIST

March 18, 2013, Rev E

Model No: ECOD-AT, ECODL-AT, ECOF-AT, ECOFL-AT SHIPBOARD ELECTRIC CONVECTION OVEN

Key Number	Part Number	Qty Per	Description
64	2E-30705-01	1	CONTC 2-SPD MTR-COIL 240
65	2E-30700-03	1	CONTC 3POLE 40A208-240VAC
66	2E-31400-04	1	XFRMR 480/240VAC 100VA
67	2E-30500-09	1	TRM BLOCK 3 POLE SMALL 95
68	2E-31800-07	1	CB 2/10 AMP 2 POLE
68	2E-31800-01	4	CB 250V 50A 1 POLE CRLNGSW
70	2E-30901-08	1	FUSE HLDR FOR SC FUSE
71	2E-30900-10	1	FUSE 15AMP 300V (SC-15)
72	2E-30303-06	2	SWT TOG ON-ON DPDT BLK
73	2E-30303-16	1	SWT TOG ON-ON BLK MOM
74	2T-30402-27	1	STAT ADJ 450 DEG 48 PILOT
75	2J-30801-03	1	TIMER MECHANICAL 5 HOUR
76	2E-30303-09	1	SWT PLATE HI/LOW
77	2E-30303-10	1	SWT PLATE ON/OFF IND
78	2E-30303-05	1	SWT PLATE ON/OFF
79 & 80	Y9-70701-19	1 ASSY	KNOB ASSY 450°F
79	2R-70702-08	1	DIAL PLATE 450o STAT
80	2R-70700-01	1	KNOB BLNK UNIVERSAL BLACK
81	2R-70701-55	1	KNOB 5 HOUR TIMER
82	2R-70702-37	1	DIAL PLATE, 5 HOUR TIMER
83	Y9-31601-01-1	1	PILOT LT 250V W/TIN CLIP
84	2S-31603-04	1	LAMPS INC 250V 50W
85	2C-20109-04	10	SCRW THD MS SS 10-32X3/8
108	2M-60306-13	1	LBL INFO STAT LABEL ECO, VENT
109	2M-60306-14	1	LBL INFO STAT LABEL ECO, TIMER
110	2M-60306-15	1	LBL INFO STAT LABEL ECO, TEMP
111	2M-60306-45	1	LABEL ECO POWER, LIGHT, SPEED
105	Q9-50301-52	1	DOOR STOP LH ARM & BRACKET ASSY
101	2C-20405-02	2	RVT SOLID 3/16X 5/8R/H
102	Q9-50301-54-1	2	DOOR STOP WASHER
103	2P-70203-01	2	BEARING STL #41 ROLLER
104	Q9-50301-55	2	DOOR STOP PAD
86	Q9-50301-54	1	DOOR STOP ARM L/H
87	2C-20111-02	2	SCRW HXHD CAP 1/4-20X3/4
88	Q9-50301-52	1	DOOR STOP LH ARM&BRACKET
89	2C-20303-01	2	NUT HX SS 1/4-20
105	Q9-50301-90	1	DOOR STOP RH ARM & BRACKET ASSY
101	2C-20405-02	2	RVT SOLID 3/16X 5/8R/H
102	Q9-50301-54-1	2	DOOR STOP WASHER
103	2P-70203-01	2	BEARING STL #41 ROLLER
104	Q9-50301-55	2	DOOR STOP PAD
86	Q9-50301-92	1	DOOR STOP ARM R/H
87	2C-20111-02	2	SCRW HXHD CAP 1/4-20X3/4
88	Q9-50301-90	1	DOOR STOP RH ARM&BRACKET
89	2C-20303-01	2	NUT HX SS 1/4-20
106	PS-50301-50	1	KIT, DOOR STOP ASSY LH
90	2C-20109-52	4	SCRW PAN HD MS SS M3X8MM
91	PS-50301-W94	1	DOOR STOP SLIDE L.H. w/STOP
92	Q9-50301-51-3	4	BACKUP WASHER
93	2A-20401-04	4	SPCER 1/8IDX3/160DX1/16LG
94	2C-20301-42	4	NUT HEX ACORN M3-A2
95	2C-20406-02	2	RVT 5/32X1 1/4 FH 100o
96	2P-51001-23	2	SPRING DOOR STOP-ECO
97	Q9-50301-51-4	2	DOOR STOP SPRING TUBE
99	Q9-50301-51-1	1	DOOR STOP LATCH L.H.
106	Q9-50301-88-1	1	DOOR STOP ASSY R/H
90	2C-20109-52	4	SCRW PAN HD MS SS M3X8MM
91	PS-50301-W93	1	DOOR STOP SLIDE R/H w/STOP
92	Q9-50301-51-3	4	BACKUP WASHER
93	2A-20401-04	4	SPCER 1/8IDX3/160DX1/16LG
94	2C-20301-42	4	NUT HEX ACORN M3-A2
95	2C-20406-02	2	RVT 5/32X1 1/4 FH 100o
96	2P-51001-23	2	SPRING DOOR STOP-ECO
97	Q9-50301-51-4	2	DOOR STOP SPRING TUBE
99	Q9-50301-89-1	1	DOOR STOP LATCH R/H
107	PS-50301-89-1	1	DOOR STOP LATCH R/H
	PS-50301-50	1	DOOR STOP LATCH L/H

STAR INTERNATIONAL HOLDINGS INC. COMPANY

Star - Holman - Lang - Wells - Bloomfield - Toastmaster
10 Sunnen Drive, St. Louis, MO 63143 U.S.A.