



## SAFETY SYMBOL



These symbols are intended to alert the user to the presence of important operating and maintenance instructions in the manual accompanying the appliance.

### **FOR YOUR SAFETY**

**DO NOT STORE OR USE GASOLINE OR OTHER FLAMMABLE VAPORS AND LIQUIDS IN THE VICINTIY OF THIS OR ANY OTHER APPLIANCE.**

### **POST IN PROMINENT LOCATION**

**INSTRUCTIONS TO BE FOLLOWED IN THE EVENT USER SMELLS GAS. THIS INFORMATION SHALL BE OBTAINED BY CONSULTING YOUR LOCAL GAS SUPPLIER. AS A MINIMUM, TURN OFF THE GAS AND CALL YOUR GAS COMPANY AND YOUR AUTHORIZED SERVICE AGENT. EVACUATE ALL PERSONNEL FROM THE AREA.**

### **WARNING**

**IMPROPER INSTALLATION, ADJUSTMENT, ALTERATION, SERVICE OR MAINTENANCE CAN CAUSE PROPERTY DAMAGE, INJURY OR DEATH. READ THE INSTALLATION, OPERATION & MAINTENANCE INSTRUCTIONS THOROUGHLY BEFORE INSTALLING OR SERVICING THIS EQUIPMENT.**



**WARNING**  
**RISK OF FIRE OR ELECTRIC SHOCK**  
**DO NOT OPEN**



**WARNING, TO REDUCE THE RISK OF ELECTRICAL SHOCK, DO NOT REMOVE CONTROL PANEL. NO USER-SERVICABLE PARTS INSIDE. REPAIRS SHOULD BE DONE BY AUTHORIZED SERVICE PERSONNEL ONLY.**

### **NOTICE**

Using any part other than genuine Lang factory supplied parts relieves the manufacturer of all liability.

Lang reserves the right to change specifications and product design without notice. Such revisions do not entitle the buyer to corresponding changes, improvements, additions or replacements for previously purchased equipment.

Due to periodic changes in designs, methods, procedures, policies and regulations, the specifications contained in this sheet are subject to change without notice. While Lang exercises good faith efforts to provide information that is accurate, we are not responsible for errors or omissions in information provided or conclusions reached as a result of using the specifications. By using the information provided, the user assumes all risks in connection with such use.

## **MAINTENANCE AND REPAIRS**

Contact your local dealer for service or required maintenance. Please record the model number, serial number, voltage and purchase & Installation Information in the area below and have it ready when you call to ensure a faster service.

Model No.: \_\_\_\_\_

Purchased From: \_\_\_\_\_

Serial No.: \_\_\_\_\_

Location: \_\_\_\_\_

Voltage: \_\_\_\_\_

Purchase Date: \_\_\_\_\_

1-Phase or 3 Phase: \_\_\_\_\_

Installed Date: \_\_\_\_\_



## **PROBLEMS, QUESTIONS or CONCERNS**

Before you proceed consult you authorized Lang service agent directory  
or  
Call the Lang Technical Service & Parts Department at 314-678-6315.

### **TABLE OF CONTENTS**

Specifications . . . . .	4
Equipment Description . . . . .	5
Unpacking . . . . .	6
Installation	
Leg Installation . . . . .	7
Leg Pad Adapter Installation . . . . .	8
Stacking the Oven. . . . .	9
Flu Installation . . . . .	9
Ventilation & Clearence . . . . .	10
Electrical Connection . . . . .	10
Gas Connection . . . . .	11
Gas Conversions . . . . .	12
Initial Start-Up	
Pre-Power On . . . . .	13
Power On . . . . .	13
General Operation & Programming	
Control Panel . . . . .	14
Typical Operation Sequence . . . . .	14
Hints & Suggestions. . . . .	15
Loading . . . . .	15
Maintenance	
Cleaning . . . . .	16
Troubleshooting	
Symptoms / Possible Causes / Test. . . . .	17
Wiring Diagram	
120VAC . . . . .	18
Exploded View & Parts List . . . . .	20-25

**NOTICE** Service on this or any other Lang appliance must be performed by qualified personnel only. Consult your Lang Authorized Service Agent Directory. You can call our toll free number 314-678-6315 or visit our website [WWW.LANGWORLD.COM](http://WWW.LANGWORLD.COM) for the service agent nearest you.

# SPECIFICATIONS

Model	Height x Width x Depth (without optional stand)	Clearance from combustible surface	Weight		
			Installed	Shipping	Freight Class
<b>GCOF</b>	38.1" x 40.2" x 38.8" 964mm x 1019mm x 985mm	Side:6", Back: 6", Floor: 6"	460 lbs. (209 kg)	500lbs (227 kg)	70
<b>GCOD</b>	38.1" x 40.2" x 46.0" 964mm x 1019mm x 1168mm	Side:6", Back: 6", Floor: 6"	540 lbs. (245 kg)	580lbs (264 kg)	70

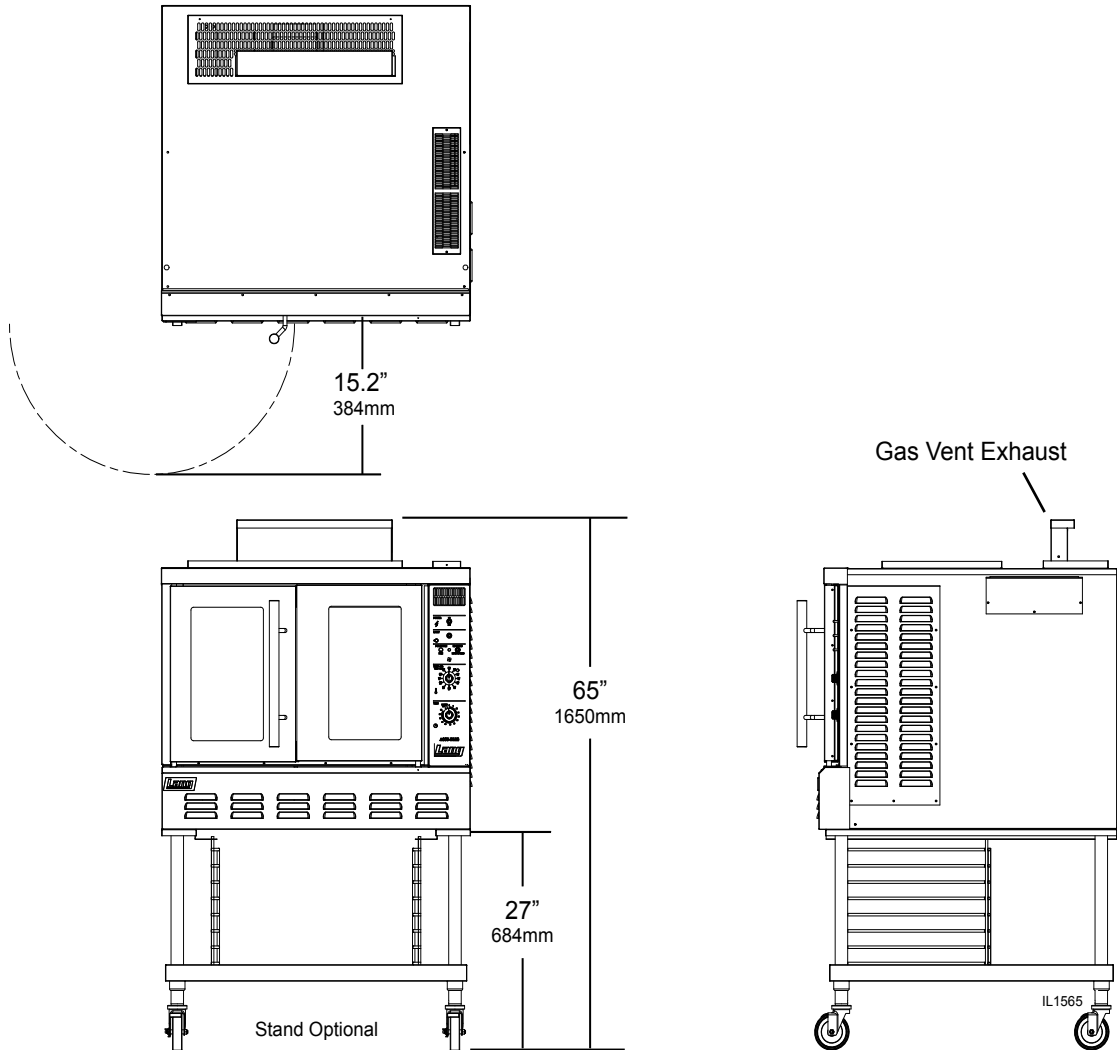

# SPECIFICATIONS

CURRENT MODEL	PREVIOUS MODEL	VOLTS AC	Hz.	AMPS	FLA	NAT.	PROPANE	BURNER INPUT
GCOD-AP-LP	GCCO-AP-XD-P	115	60	7.1	5		X	60000
GCOD-AP-NAT	GCCO-AP-XD-N	115	60	7.1	5	X		60000
GCOF-AP-LP	GCCO-AP-P	115	60	7.1	5		X	55000
GCOF-APLP220	GCCO-AP-PE	220	60	3.6	5		X	55000
GCOF-AP-NAT	GCCO-AP-N	115	60	7.1	5	X		55000
GCOF-APNATCP	GCCO-AP-NCP	115	60	7.1	5	X		55000
GCOFSD-APNAT	GCCO-APSD-N	115	60	7.1	5	X		55000
GCOFSD-APNCP	GCCO-APSDNCP	115	60	7.1	5	X		55000

## EQUIPMENT DESCRIPTION

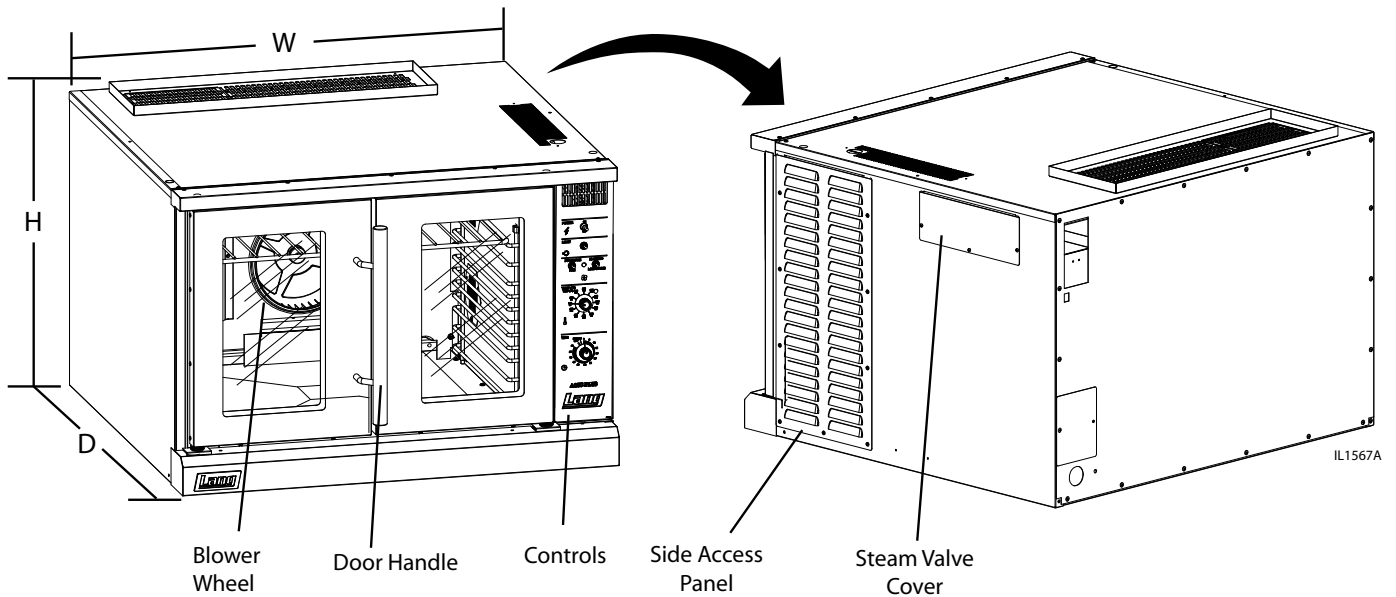

### Exterior Construction

The oven exterior dimensions are listed in the Specification Section. The Top, Front, Back, and Sides are constructed of heavy duty 430 stainless steel, with an attractive No. 4 finish.

The ovens simultaneous-opening heavy duty doors come standard with double pane windows.

The door handle is constructed of Stainless Steel and Phonolic Tubing.

The oven cavity is insulated with high temperature insulation for efficiency and reduced heat loss.

### Interior Construction

The GCOF oven cavity dimensions are 29" (72.5 cm) Wide, 20" (50.84 cm) High, 21" (53.38 cm) Deep.

The GCOD oven cavity dimensions are 29" (72.5 cm) Wide, 20" (50.84 cm) High, 27" (53.38 cm) Deep.

The interior of the oven is constructed of porcelainized stainless steel.

### Operation

The GCOD-AP and GCOF-AP ovens are forced air convection ovens with a vented oven cavity.

The air is driven by a 1/3 HP fan motor.

### Controls

Easy to use manual control knobs.

Solid state temperature sensing and controls.

Pulse and two-speed fan.

### Technical

The GCOD-AP and GCOF-AP ovens has electronic ignition and requires a 120V single-phase connection.

Floor space required is 48" (122.6 cm) wide, 44" (112.5 cm) deep.

The oven weighs 500 lbs.

Contact the factory for correct orifice sizes when installing oven above 4000 ft.

**NOTICE**     **The data plate is on the back side of the oven above the power cord. The oven voltage, wattage, serial number, wire size, and clearance specifications are on the data plate. This information should be carefully read and understood before proceeding with the installation.**

## UNPACKING

### Receiving the Oven

Upon receipt, check for freight damage, both visible and concealed. Visible damage should be noted on the freight bill at the time of delivery and signed by the carrier's agent. Concealed loss or damage means it does not become apparent until the merchandise has been unpacked. If concealed loss or damage is discovered upon unpacking, make a written request for inspection by the carrier's agent within 15 days of delivery. All packing material should be kept for inspection. Do not return damaged merchandise to Star Manufacturing Company. File your claim with the carrier.

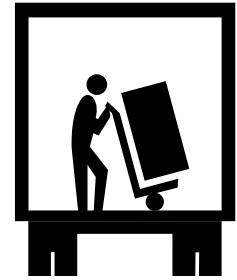

### Location

Prior to un-crating, move the oven as near to its intended location as practical. The crating will help protect the unit from the physical damage normally associated with moving it through hallways and doorways.

### Un-crating

The oven will arrive completely assembled inside a wood frame and strapped to a skid. Cut the straps and remove the wood frame.

The oven can now be removed from the skid.



**CAUTION**

**EACH UNIT WEIGHS 500 LBS. FOR SAFE HANDLING, INSTALLER SHOULD OBTAIN HELP AS NEEDED, OR EMPLOY APPROPRIATE MATERIALS HANDLING EQUIPMENT (SUCH AS A FORKLIFT, DOLLY, OR PALLET JACK) TO REMOVE THE UNIT FROM THE SKID AND MOVE IT TO THE PLACE OF INSTALLATION.**

**ANY STAND, COUNTER OR OTHER DEVICE ON WHICH OVEN WILL BE LOCATED MUST BE DESIGNED TO SUPPORT THE WEIGHT OF THE OVEN.**

**SHIPPING STRAPS ARE UNDER TENSION AND CAN SNAP BACK WHEN CUT.**

# INSTALLATION

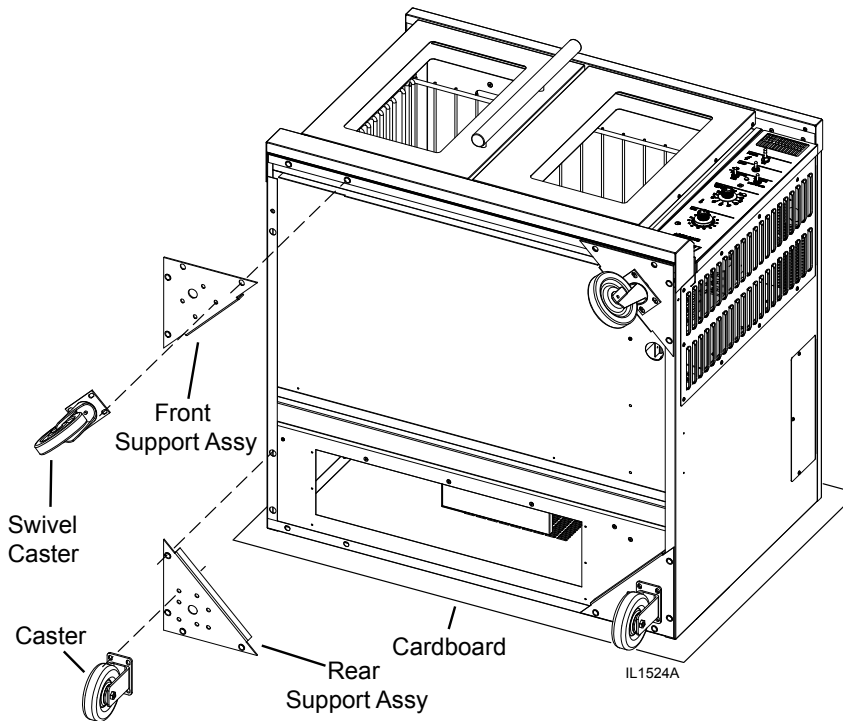

**Above:** typical leg and caster installation.  
**Below:** accessory options, legs, casters & equipment carts sold separately. Follow installation instructions with the each specific kit.

## Leg Installation

Legs are available separately for both the single and double deck installations. Single deck installations require a 27-inch leg or equipment cart. Double deck installations require 6-inch legs or casters. All these are available separately.

Place some cardboard on the ground and with assistance carefully lay the unit on its back. In stacked

The adjustable feet may be screwed in or out as necessary to level the oven. A torpedo level placed on an oven rack will assist in leveling the oven.

## Double-Stack Ovens

To install the 6-inch legs, adj. feet or casters on the lower unit, follow the Leg Pad instructions in the following section or in the instructions included with the leg pads.

## Single Oven

To install 27" legs or cart to your unit, place the unit laying on its back onto a piece of cardboard. Be sure to read all instructions & follow the instructions provided with the kit.

## 27" Leg Installation

With unit in position, fasten the two legs to the front corner pads then to the oven's front corners using the four 5/16 inch bolts provided in the leg kit. See leg pad adapter illustration to determine differences between front & rear support assemblies.

Lift the oven onto its front legs and block the back up using one of the 27-inch legs set upside down in the center rear of the oven body. Install the third 27-inch leg onto the oven body on the control side rear. Gently lift the oven rear, remove the temporary support leg & install it on the last rear corner.

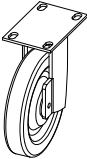
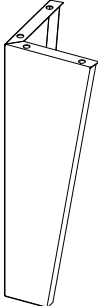
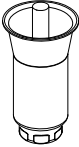
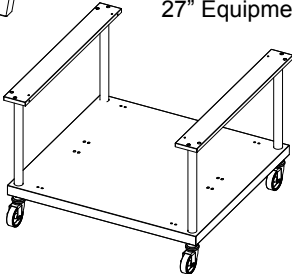
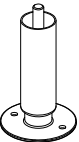
Accessory Options	
Stacked Units	Single Units
 <p>Caster Sets</p>	 <p>27" Leg Set (marine also)</p>
 <p>6" Adj. Leg Sets</p>	 <p>27" Equipment Cart</p>
 <p>6" Adj. Bolt Down Leg Sets (marine only)</p>	

## INSTALLATION cont.

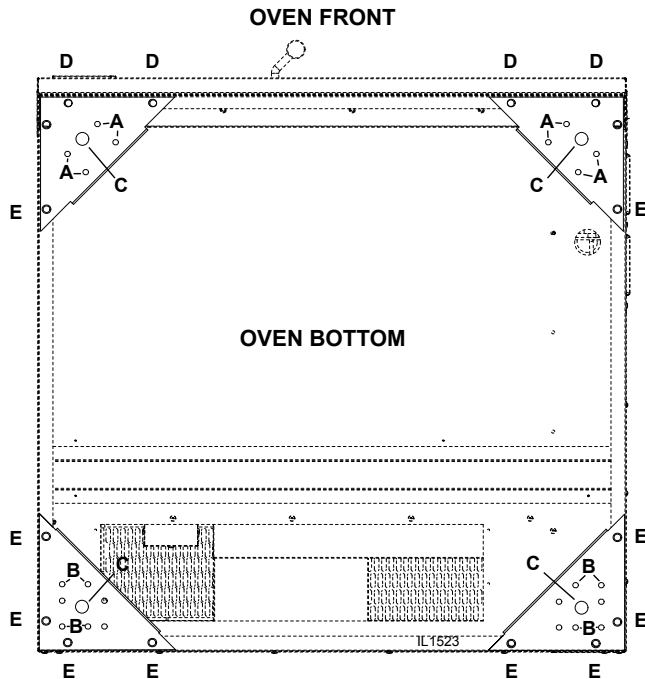

**Above:** Bottom on unit showing the placement of the leg adapters and their hole assignment.

### Leg Pad Adapter

Identify the front and rear leg adapters (the front adapters have two threaded inserts, the rear has four). The leg adapters are included with each specific accessory kit.

#### Leg to Adapter Installation:

Install the leg's threaded stud through the hole in the adapter labeled "C" with the bent flange of the adapter facing away from the leg.

Screw the 3/4-inch nut supplied in the adapter kit onto the leg stud and tighten. Secure to oven using hardware provided.

#### Caster to Adapter Installation:

Place the swivel caster against the front leg pad adapter with the flange of the adapter facing away from the caster.

Install the four 5/16 inch bolts through the caster base and the adapter holes labeled "A" then install the 5/16 inch nuts with washer and lock washers.

Place the rigid casters against the rear leg adapter with the flange of the adapter facing away from the caster.

Align the caster to the holes in the adapter labeled "B". **NOTE:** There are two sets of "B" holes set at 90° from the each other. One set will create a left rear adapter and the other set will create a right rear adapter.

Install four 5/16-inch bolts through the caster base and the adapter holes labeled "B" then install 5/16-inch nuts with lock washers and flat washers.

#### Adapter to Oven Installation:

Gently tip the oven onto its back. Place the front leg adapter into the front corners of the oven. The holes without the threaded inserts face the front of the oven and the flange on the adapter points toward the bottom of the oven.

The edge of the leg adapter with the threaded insert slips under the flange on the oven side, while the edge without the inserts sits on top of the threaded angle on the oven front.

Install two 3/8-inch bolts with lock washers and flat washers through the front holes "D" in the leg adapter and into the threaded inserts on the oven.

Thread one 3/8-inch bolt with lock washer and flat washer into the rear threaded hole labeled "E" on each of the leg adapters.

The forward threaded hole on the front leg adapter does not get a bolt installed.

Place the rear leg adapters into the rear corners of the oven so that the adapter is under the flange of the oven side and back.

**NOTE:** If installing a caster place the adapter on the oven so that the casters roll forward.

Install for 3/8-inch bolts with lock washers and flat washers through the holes labeled "E" in the flange of the oven and into the threaded inserts of the leg adapter.

## INSTALLATION cont.

### Stacking the Ovens

Remove all the plug buttons from the top of the lower oven.

Remove the stacking kit from the oven compartment of one oven and install the 1 1/4-inch plastic bushing into the top of the lower oven.

Tip the top oven backwards and install two 3/8-inch socket head bolts, found in the stacking kit, into the two front leg holes that match the holes in the top of the lower oven. Install the socket head bolts with the heads of the bolt pointing away from the oven.

Lift the top oven and gently set on top of the lower oven so that the heads of the socket head bolts nest into the holes in the top of the lower oven.

**NOTE: Each unit must have separate electrical connections**

### Flu Installation

A flu extension must be installed on the upper oven of a stacked set.

The extension directs the heat of the lower unit away from the motor of the upper unit. Without this installed, the upper unit can experience problems including premature motor failure.

**This extension must be installed.**

The ovens may now be set into position. Be careful if sliding the ovens, they are not designed to slide over cracks or obstructions in the floor.

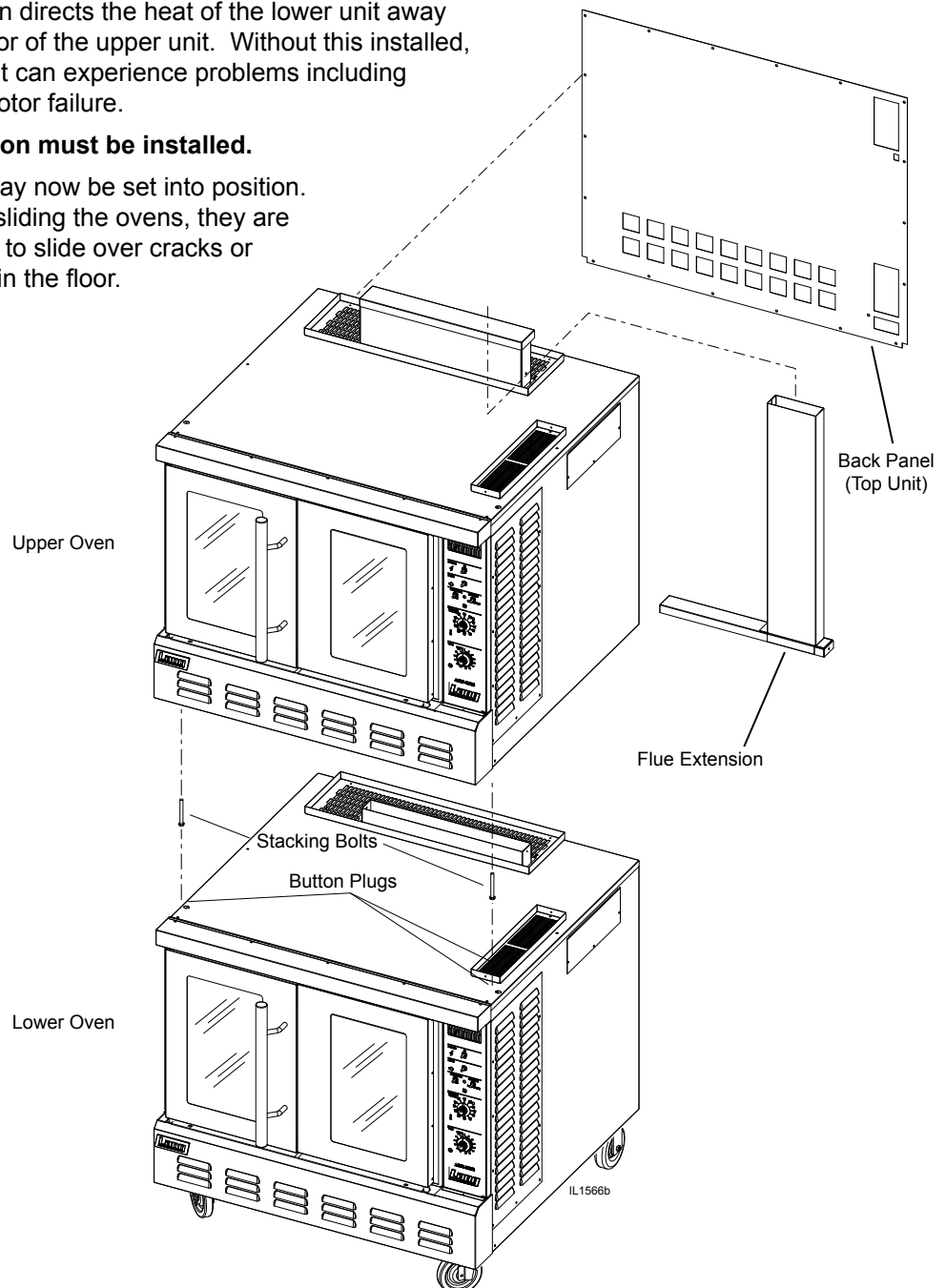

## INSTALLATION continued

### Ventilation and Clearances

Standard minimum clearance from combustible construction is as follows.

4" from side

4" from back

6" from floor

- These ovens may be set directly, without legs, on a curbed base or **non-combustible** floor.
- If the oven is set without legs on a **non-combustible** floor or a curbed base, maintain a 4-inch back clearance.
- If the oven is set directly against a **non-combustible** back wall, maintain a 4-inch clearance to the floor.
- **Do not** install the oven closer than 4 inches from another oven on the right hand side (control panel side).
- **Do not** install the oven closer than 12 inches from an uncontrolled heat source (char broiler etc.) on the right side.
- Keep the area free & clear of combustible material, and do not obstruct the flow of combustion or ventilation air.
- The installation of any components such as a vent hood, grease extractors, and/or fire extinguisher systems, must conform to the applicable nationally recognized installation standards.



**THIS APPLIANCE IS EQUIPPED WITH A 3-PRONG (GROUNDING) PLUG FOR YOUR PROTECTION AGAINST SHOCK HAZARD AND MUST BE PLUGGED DIRECTLY INTO A PROPERLY GROUNDED 3-PRONG FROM THE PLUG.**

### Electrical Connection

The electrical connection must be made in accordance with local codes or in the absence of local codes with NFPA No. 70, latest edition (in Canada use: CAS STD. C22.1).

The electrical service entrance is provided by a cord and plug located at the oven back directly behind the control compartment.

Each oven requires a 115-volt grounded supply and 7.1 amps.

Supply wire size must be large enough to carry the amperage load for the number of ovens being installed. Wire size information can be found on the oven data plate.

**NOTICE: THE INSTALLATION OF THIS UNIT MUST CONFORM TO APPLICABLE NATIONAL, STATE, AND LOCALLY RECOGNIZED INSTALLATION STANDARDS.**

**NOTICE: THE INSTALLATION OF ANY COMPONENTS SUCH AS A VENT HOOD, GREASE EXTRACTORS, FIRE EXTINGUISHER SYSTEMS, MUST CONFORM TO THEIR APPLICABLE NATIONAL, STATE AND LOCALLY RECOGNIZED INSTALLATION STANDARDS.**

## INSTALLATION continued

### Gas Connection

This appliance is manufactured for use with the type of gas indicated on the data plate. Contact the factory if the gas type does not match that which is on the data plate.

All gas connections must be in accordance with local codes and comply with the National Fuel Gas Code ANSI Z223.1 latest edition.

An internal gas pressure regulator is located inside the control compartment.

Gas must be delivered to the appliance regulator at less than 1/2 pound of pressure and less than 1/2-inch water column pressure drop.

The internal regulator is preset at the factory, however, due to gas pressure variations from area to area; it may be necessary to make minor adjustments to the regulator to provide the manifold pressure indicated on the data plate. This should be 5 inches water column for natural gas and 10-inch water column for propane. A 1/8-inch NPT tap is provided on the main manifold for checking regulator pressure. Access the main manifold by removing the bottom trim piece below the oven doors.

When replacing the 1/8-inch plug in the main manifold a joint sealant that is resistant to the action of liquid petroleum gas must be used.

The supply piping must be of sufficient size to provide 55,000 BTU/hr per oven. A 1/2-inch NPT connection is provided at the rear of the oven directly behind the control compartment. Connect each oven separately.

A gas shut off valve must be installed to the oven(s) and located in an accessible area.

This appliance and its individual shutoff valve must be disconnected from the gas supply piping system during any pressure testing of that system at test pressures in excess of 1/2 PSIG and the appliance must be isolated from the gas supply piping system by closing its individual manual shutoff valve during any pressure testing of the gas supply system at test pressures equal to or less than 1/2 PSIG.

Test for gas leaks. Use a commercial leak detector or a soap and water solution.



**CONVECTION OVENS INSTALLED WITH CASTERS MUST HAVE THE FOLLOWING: A CONNECTOR THAT COMPLIES WITH THE STANDARD FOR CONNECTORS FOR MOVABLE GAS APPLIANCES ANSI Z21.69 LATEST EDITION, A QUICK DISCONNECT THAT COMPLIES WITH THE STANDARD FOR QUICK DISCONNECT DEVICES FOR USE WITH GAS FUEL, ANSI Z21.141 LATEST EDITION, A TETHER OR OTHER MEANS TO LIMIT APPLIANCE MOVEMENT WITH OUT RELIANCE ON THE GAS SUPPLY PIPING. SECURELY ATTACH THE TETHER TO THE EYEBOLT PROVIDED AT THE REAR OF THE APPLIANCE.**

## INSTALLATION continued

### Gas Conversions

1. Disconnect oven from power and gas.
2. Remove bottom trim piece from oven (2 hex head bolts and 1 Phillips screw).
3. Remove side panel from oven.
4. Disconnect black manifold pipe from 3/8" aluminum pipe at the furrel nut.
5. Remove two Phillips screws holding black manifold pipe to oven.
6. Remove black manifold pipe from oven.
7. Remove both burner orifices from manifold and replace with new orifices, making sure to apply pipe thread compound.
8. Remove two Phillips screws holding pilot assembly to oven.
9. Remove pilot assembly from oven.
10. Remove 1/4" aluminum pipe from pilot assembly.
11. Remove pilot orifice and replace with new pilot orifice.
12. Re-attach 1/4" aluminum pipe to pilot assembly.
13. Re-attach pilot assembly to oven.
14. Re-install black manifold assembly to oven, making sure that the orifice goes into the burner tubes.
15. Re-attach 3/8" aluminum pipe to black manifold assembly.
16. Remove the seal screw from the combination gas valve.
17. Remove the adjustment screw and spring from the combination valve.
18. Insert new spring into the valve and adjustment screw.
19. Re-connect oven to power and gas and check for leaks using a soap solution.
20. Adjust gas pressure to correct water column (5"NG, 10"LP).
21. Install new seal screw provided in kit and affix "Caution" sticker to the visible side of the combination valve.
22. Re-install bottom trim piece and side panel.

**NOTICE**      **Kits designed to accommodate ovens from sea level to 5000 feet.**  
**Contact factory for orifice sizes on installations above 5000 feet.**

#### NG to LP

Part No.	Description	Qty.
2A-80401-05	Pilot Orifice, Drilled .010	1
Y9-80400-14	Main Burner Orifice, Drilled #53	2
2V-80505-11	Combination Gas Valve Spring, Includes: 1. Spring 2. Seal Screw 3. Caution Sticker	1

#### LP to NG

Part No.	Description	Qty.
2A-80401-10	Pilot Orifice, Drilled .018	1
Y9-80400-13	Main Burner Orifice, Drilled #43	2
2V-80505-16	Combination Gas Valve Spring, Includes: 1. Spring 2. Seal Screw 3. Caution Sticker	1

## INITIAL START UP

### Pre-Power On

After the oven is installed and connected to power, prior to turning on, verify the following:

- The doors open and close freely.
- All racks are in the oven correctly.
- All packing materials have been removed from the inside of the oven.
- All power and gas connections are tight.

### Power On

The pilot burner is electronically ignited. When the oven power switch is turned On the pilot will light.

There is a lockout safety feature on the spark ignition module. If, during the initial start-up, the pilot does not light within 30 seconds the module will turn off all gas to the pilot burner. To reset the spark module, turn Off the power switch for 10 seconds then turn the switch back On. This may need to be repeated several times during the initial start-up until gas is present at the pilot burner.

**NOTICE**      **During the first few hours of operation you may notice a small amount of smoke coming off the oven, and a faint odor from the smoke. This is normal for a new oven and will disappear after the first few hours of use.**



**WARNING**      **BEFORE LIGHTING USE A SOAP AND WATER SOLUTION TO TEST ALL JOINTS FOR GAS LEAKS.**

# General Operation & Programming

Convection ovens constantly circulate air over and around the product. This strips away the thin layer of moisture and cool air from around the product allowing heat to penetrate more quickly.

Cooking times can be shortened and cooking temperatures can be reduced.

To convert standard deck oven recipes, reduce the temperature 50° degrees and the time by 25%.  
Make minor adjustments as necessary.

Always weigh your product. This will give you a more consistent size, color and quality.

Check the product near the end of the initial cooking.

Do not open the oven door during baking, as this will change the baking characteristics of the oven and make it difficult to determine a final program.

If the product is overdone on the outside and underdone on the inside, reduce the baking temperature.

If the product is pulling away from the edge of the pan, the temperature is too high or the cooking time too long.

A convection oven is a mechanical piece of equipment. The same control settings will always give the same results.

If the results vary, problems may be because of changes in the product preparation.

## GCOF-AP / GCOD-AP Control Panel

The Control panel consists of the following items.  
Detailed operational descriptions are given later in this section.

**Power:** Turns the oven on and off

**Pulse Fan:**

*Pulse Setting:* Fan will only turn ON, when the oven is calling for heat.

*Fan Setting:* Fan is on continuously, speed is determined by the Hi/Low switch.

**Hi/Low Speed Fan:** Dual speed switch. Toggles the fan between high & low speed.

**Temperature Control:** Allows temperature to be set in 25°F increments from 140°F to 450°F

**Timer:** Electronic on-hour timer with continuous beeper,

## Typical Operation Sequence

Action	Result
Turn Power Switch to ON	Control panel heat call light comes on.
Adjust temperature, between 140°F & 450°F and allow 20 minutes for preheating	Oven begins heating
Open oven door and insert product, set timer up to 60 minutes.	Timer begins counting down.
Timer beeps continuously when done.	Product should now be done.

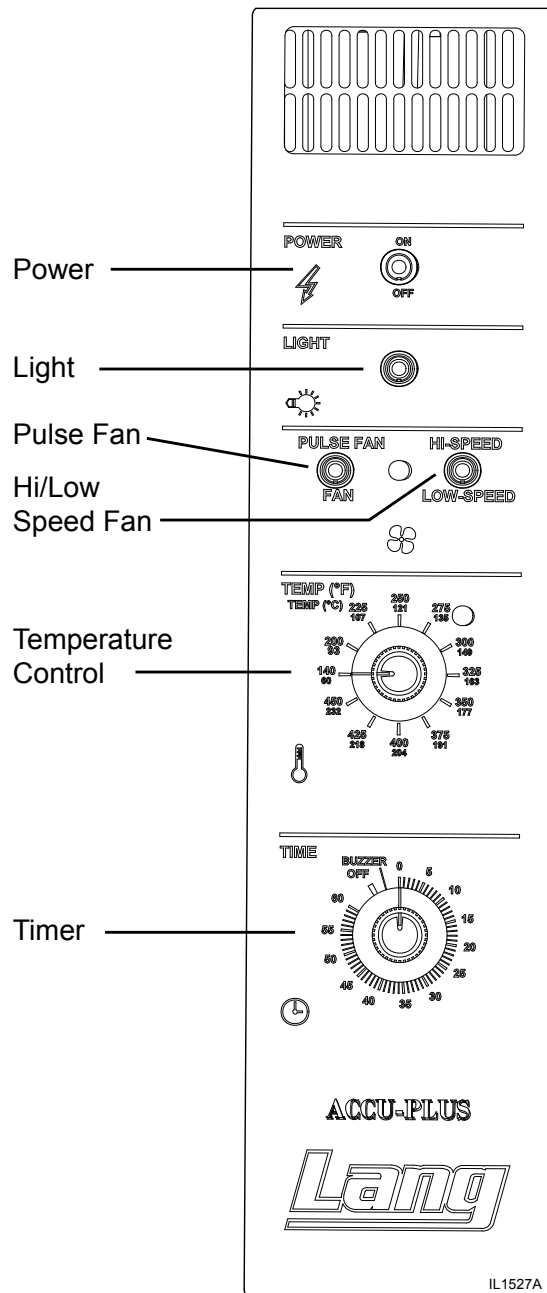

## General Operation & Programming cont.

### Hints & Suggestions

Convection ovens constantly circulate air over and around the product. This strips away the thin layer of moisture and cool air from around the product allowing heat to penetrate more quickly.

Cooking times can be shortened and cooking temperatures can be reduced.

To convert standard deck oven recipes, reduce the temperature 50 degrees and the time by 25%. Make minor adjustments as necessary.

The lower the oven temperature the more even the bake.

Always weigh your product. This will give you a more consistent size, color and quality.

Check the product near the end of the initial cooking cycle by turning on the oven light and looking through the oven door windows.

Do not open the oven doors during baking as this will change the baking characteristics of the oven and make it difficult to determine a final program.

If the product is overdone on the outside and underdone on the inside, reduce the baking temperature.

If the product is pulling away from the edge of the pan, the temperature is too high or the cooking time too long.

The convection is a mechanical piece of equipment. The same control settings will always give the same results. If the results vary, problems may be because of product preparation.

Opening the vent will allow moisture to escape the cooking chamber during part or all of the cooking process. This will allow a more crispy product, example: french fries, fish, crispy crusts. Close the vent for dough products like cinnamon rolls, breads. This is something to experiment with to determine what is best for your specific menu.

### Loading

Here are some things to remember when loading your oven.

- When loading and unloading the oven, stage products and racks so the oven door is opened for the least amount of time.
- Be sure that racks are level within the oven.
- Bent or warped pans can greatly affect the evenness of the cook or bake.
- If using baker's parchment, be sure the parchment does not blow over the product. That will create an uneven bake.
- Load each shelf evenly. Spaces should be maintained equally between the pan and oven walls, front and back.
- Do not overload pan's this will create an uneven bake.
- For best baking results, load the oven from the center out during random loading.



**ALWAYS KEEP THE AREA NEAR THE APPLIANCE FREE FROM COMBUSTIBLE MATERIALS.**

**KEEP FLOOR IN FRONT OF EQUIPMENT CLEAN AND DRY. IF SPILLS OCCUR, CLEAN IMMEDIATELY, TO AVOID THE DANGER OF SLIPS OR FALLS.**

## MAINTENANCE

- Oven interiors should be wiped down daily and thoroughly cleaned weekly using warm water and mild detergent. **DO NOT use caustic cleaners.**
- The appliance should be thoroughly checked at six-monthly intervals by a qualified technician (heating unit, mechanical stability, corrosion...) with particular emphasis on all control and safety devices.

### CLEANING

- Always start with a cold oven.
- The stainless exterior can easily be cleaned using stainless steel cleaner.
- Always follow the cleaner manufacturer's instructions when using any cleaner.
- Care should be taken to prevent caustic cleaning compounds from coming in contact with the fan wheel.
- The oven racks, rack slides, may be cleaned outside the oven cavity using oven cleaner.
- Using any harsh chemicals will result in the removal of the ETC coating and etching of the porcelain below it. The oven interior should only be cleaned using a mild soap and a non metal scouring pad. **DO NOT use caustic cleaners.**
- Always apply stainless steel cleaners when the oven is cold and rub in the direction of the metal's grain.



**WARNING**

**KEEP WATER AND SOLUTIONS OUT OF CONTROLS. NEVER SPRAY OR HOSE CONTROL CONSOLE, ELECTRICAL CONNECTIONS, ETC.**



**CAUTION**

**MOST CLEANERS ARE HARMFUL TO THE SKIN, EYES, MUCOUS MEMBRANES AND CLOTHING. PRECAUTIONS SHOULD BE TAKEN TO WEAR RUBBER GLOVES, GOGGLES OR FACE SHIELD AND PROTECTIVE CLOTHING.**

**CAREFULLY READ THE WARNING AND FOLLOW THE DIRECTIONS ON THE LABEL OF THE CLEANER TO BE USED.**

**NEVER LEAVE A CHLORINE SANITIZER IN CONTACT WITH STAINLESS STEEL SURFACES LONGER THAN 10 MINUTES. LONGER CONTACT CAN CAUSE CORROSION.**

# Troubleshooting

## Symptoms & Possible Causes

The following are charts of Symptoms and Possible Causes to aid in diagnosing faults with your unit.

Refer to the symptoms column to locate the type of failure then to the Possible Cause for the items to be checked.

To test for a possible cause refer to test to identify test procedures. Test indicated with an "\*" should be done by a Lang factory authorized service representative.

SYMPTOM	POSSIBLE CAUSE	Possible Cause	TEST	
Power indicator is not lit.	No power to cord outlet	Product is cooked too long	No test available, operational condition	
	Oven unplugged from outlet	Failed Probe	Check probe for proper resistance*	
	Failed power cord or plug	Failed Circuit Board	Confirm that board is getting correct voltage*	
	Failed power switch		Confirm that board is putting out correct voltage*	
	Failed indicator light	Failed Valve	Remove the wires and check for continuity across the coil*	
	Failed pilot ignition	Failed Centrifugal switch in Motor	Remove the wires and check for continuity across them while motor is turning*	
Oven will not heat	Power Switch is not "ON"		Failed Motor contactor	Remove the wires from the contactor coil and check for continuity across the contactor coil connection*
	Failed Pilot ignition			Ensure the contactor moveable points move freely up and down*
	Failed 12-position switch		Failed Motor	Confirm that motor is getting correct voltage*
	Failed Circuit Board			Failed or disconnected safety thermostat
	Failed Probe		Failed Spark Module	
	Failed Contactor			
	Failed Centrifugal switch in Motor			
	Failed Motor			
	Failed Over-temperature Thermostat			
	Failed Valve			
Product burning	Product is cooked too long			
	Failed 12-position switch			
	Failed circuit board			
	Failed probe			
Product under done	Product is not cooking long enough			
	Failed 12-position switch			
	Failed circuit board			
	Failed probe			

**NOTICE** If an item on the list is followed by an asterisk (\*), the work should be done by a Lang factory authorized service representative.



**CAUTION**

**USE OF ANY REPLACEMENT PARTS OTHER THAN THOSE SUPPLIED BY LANG OR THEIR AUTHORIZED DISTRIBUTORS CAN CAUSE BODILY INJURY TO THE OPERATOR AND DAMAGE TO THE EQUIPMENT AND WILL VOID ALL WARRANTIES.**

**NOTICE**

**Service on this or any other Lang appliance must be performed by qualified personnel only. Consult your Lang Authorized Service Agent Directory. You can call our toll free number 314-678-6315 or visit our website [WWW.LANGWORLD.COM](http://WWW.LANGWORLD.COM) for the service agent nearest you.**



**WARNING**

**BOTH HIGH AND LOW VOLTAGES ARE PRESENT INSIDE THIS APPLIANCE WHEN THE UNIT IS PLUGGED/WIRED INTO A LIVE RECEPTACLE. BEFORE REPLACING ANY PARTS, DISCONNECT THE UNIT FROM THE ELECTRIC POWER SUPPLY.**

REVISION BLOCK					
REV	ECN NO.	DESCRIPTION	DLG	DR	DATE
B		TOOK OUT ISOLATION XFMR			09-03-03

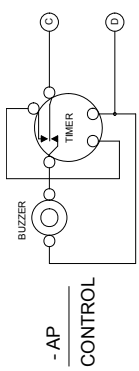

NOTE:  
MODEL GCCO-S USES  
A MECHANICAL TIMER

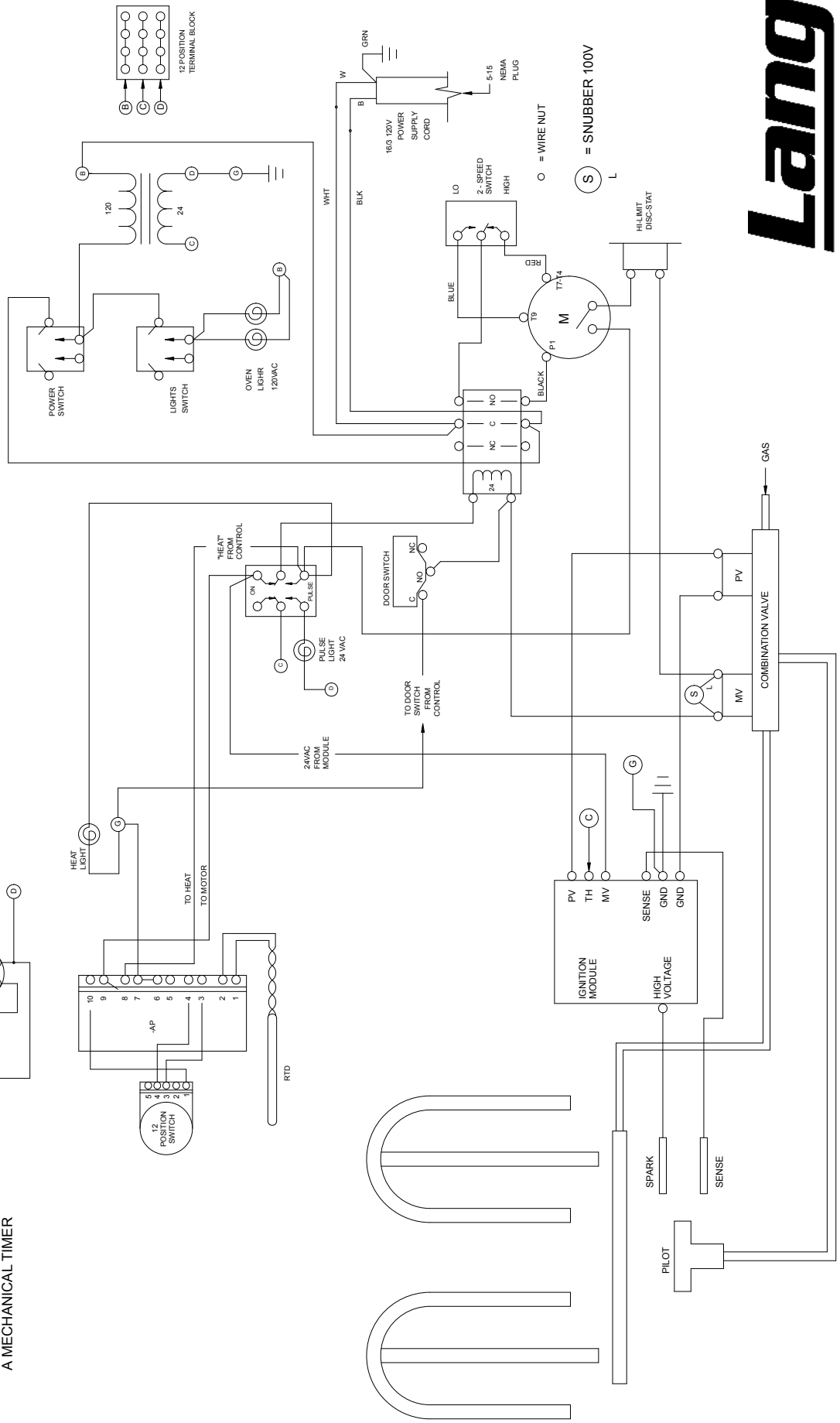

2M-61111-115, Rev. B, 9/03/03

Model: GCCO-AP (S) 120V

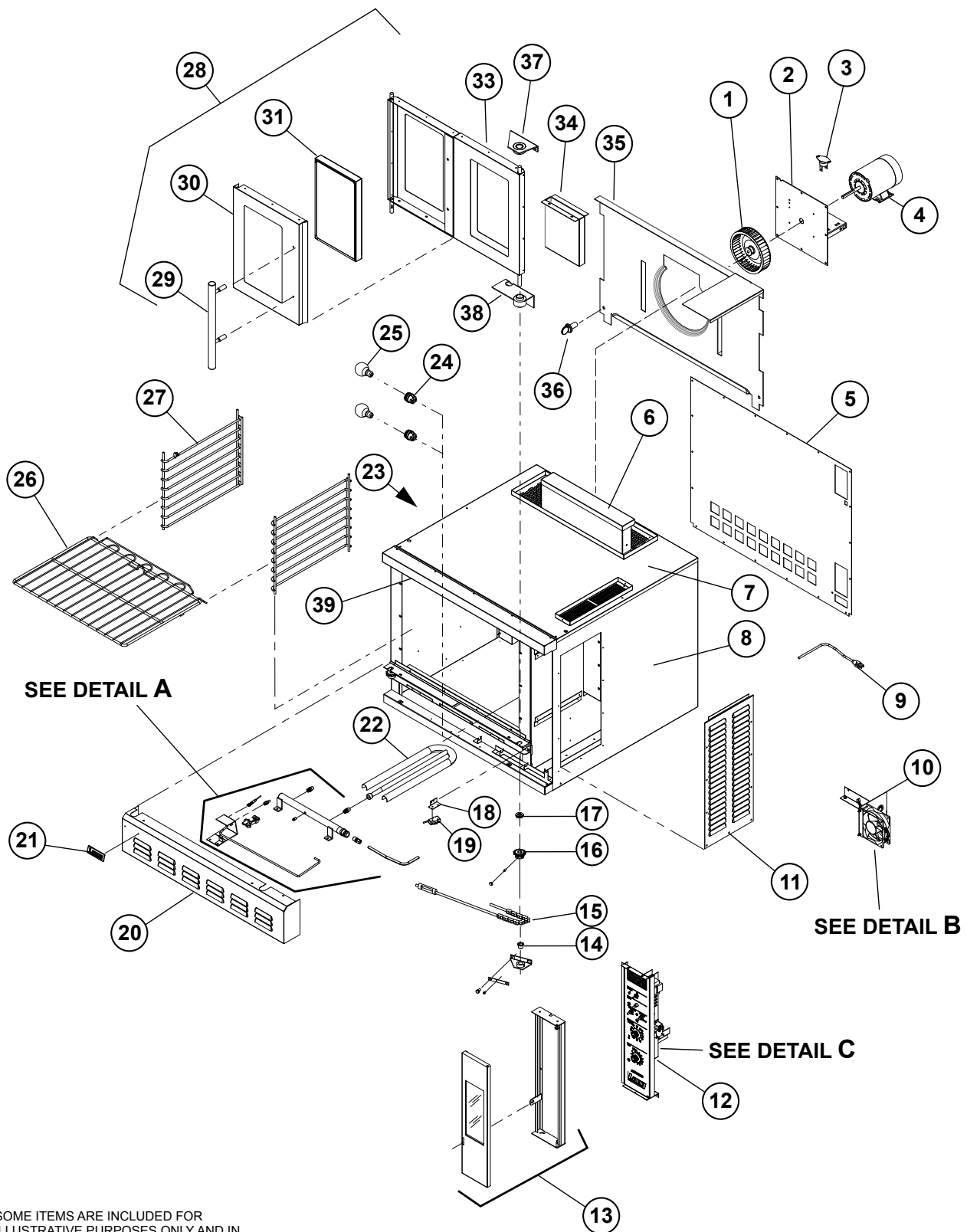

SOME ITEMS ARE INCLUDED FOR ILLUSTRATIVE PURPOSES ONLY AND IN CERTAIN INSTANCES MAY NOT BE AVAILABLE

**Model:**  
GCOD/F-AP-NAT & GCOD/F-AP-LP  
Gas Convection Oven

**Lang**<sup>®</sup>

SK2309

Rev. G 06/17/15

# PARTS LIST

October 13, 2014, Rev B

## Model No:GCOD-AP-NAT, GCOD-AP-LP, GCOF-AP-NAT, GCOF-AP-LP GAS FULL SIZE CONVECTION OVEN

Key Number	Part Number	Qty Per	Description	
1	2U-71500-05	1	BLOWER WHEEL ECCO/GCCO	ALL
2	Q9-60102-1404-1	1	GCCO MOTOR MOUNT ASSY (NO MOTOR)	ALL
3	2T-30401-09	1	STAT FXD 500 DEG OPEN	ALL
4	PS-30200-35	1	REPLACEMENT MOTOR	ALL
5	Q9-GCCO-181	1	BODY BACK	ALL
	Q9-GCCO-429-1	1	BODY BACK - CORRECTIONAL	GCOF-APNATCP, GCOFLAPNATCP, GCOFSD-APNCP, GCOFSD-APNAT, GCOFSD-APCP
6	Q9-GCCO-264-1	1	FLUE DEFLECTOR SPOT	ALL
	Q9-GCCO-264-2	1	FLUE DEFLECTOR SPOT C.P.	GCOFLAPNATCP, GCOFSD-PNCP, GCOF-APNATCP
7	LM-GCCO-154	1	CAN TOP ASSY	GCOF-AP
	Q9-60102-1403	1	GCCO TOP PANEL ASSY w/ MNT HRD	GCOD-AP
8	LM-ECCO-152	1	CAN SIDE ASSY R/H	GCOF-AP
8	Q9-60102-1402	1	GCCO RIGHT SIDE S/S EXTRA DEEP w/ MNT HRD	GCOD-AP
9	2E-31107-02	1	CORD SET 14/3 X 8' 15A	ALL
10	Q9-60102-171		GCCO COOLING FAN KIT 120V	
	Q9-60102-1711		GCCO COOLING FAN KIT 220V	
11	Q9-60102-904	1	ACCESS COVER - ECCO/GCCO, & HRDWR	ALL
12	Q9-GCCOPAP	1	PANEL GCCO ACCU-PLUS	
13	L9-50310-04	1	CONTROL DOOR COVER ASSY	CORRECTIONAL PACKAGE
14	2P-70201-06	4	BRNZBRFLN 5/8ID X 3/4OD X 5/8	ALL
15	Q9-50312-02	2	DOOR CHAIN AND TURNBCKL	ALL
16	2P-73000-03	1	SST SPRKT40B11 5/8 BORE	ALL
17	2C-20201-15	10	WSHR FLT 960-C1016 PLTD	ALL
18	Q9-ECCO-145-1	1	MICRO SWITCH BRACKET	ALL
19	2E-30301-02	1	SWITCH, MICRO	ALL
20	Q9-60102-115		BOTTOM PANEL WELD ASSY w/ LOGO	ALL
	Q9-GCCO-233-2	1	BOTTOM PANEL ASSY	ALL
21	2M-60301-43	1	DIE CAST PLT LANG SATIN	ALL
22	Q9-GCCO-257-W1	2	BURNER WELD ASSEMBLY	ALL
23	LM-ECCO-155	1	LEFT CAN SIDE ASSEMBLY	GCOF-AP
	M9-60102-14021	1	GCCO LEFT SIE S/S EXTRA DEEP w/ MNT HRD	GCOD-AP
24	2E-31602-04	2	LAMP SKT SNAP-IN WHT	ALL
25	2S-31603-09	2	LAMPS INC 120V 40W	ALL
26	2B-50200-20	5	RACK ECCO/GCCO OVEN	GCOF-AP
	2B-50200-31	5	RACK ECO DEEP OVEN ONLY	GCOD-AP
27	2B-50200-93	2	RACK SLIDE 11 POS	GCOF-AP
	2B-50200-94	2	RACK SLIDE 11 POS E&GCCO-T	GCOD-AP
28	Q9-50312-44	1	LH DOOR ASSY E/GCCO	ALL
	Q9-50312-441	1	LH DOOR ASSY E/GCCO SOLID	GCOFSD
29	Y9-50312-05	1	HANDLE ASSY 1 HANDLE	ALL
30	Q9-50312-47	1	LH OUTER DOOR	ALL
31	2Q-71301-04	1	WINDOW ASSY 9-5/8X16-5/8	ALL
33	Q9-50312-43	1	RH DOOR ASSY E/GCCO	ALL
	Q9-50312-431	1	RH DOOR ASSY E/GCCO SOLID	GCOFSD
34	Q9-GCCO-161	1	SNORKEL ASSY	ALL
35	Q9-GCCO-224-2	1	BAFFLE REAR ASSY	ALL
36	2C-20112-02	4	SCREW SHLDR THUMB	ALL
37	Q9-60102-99-2	2	BEARING BRACKET ASSY TOP	ALL
38	Q9-60102-99	2	BEARING BRACKET ASSY BOTTOM	ALL
39	Q9-60102-1403	1	GCCO FRONT TOP PANEL ASSY	ALL
NI	2A-80400-01	2	ORIFICE SPUD UNDRILLED	GCOD-AP-NAT
NI	2A-80400-01	4	ORIFICE SPUD UNDRILLED	GCOD-AP-LP
NI	2E-41100-08	1	SENSOR ECCO/GCCO TEMP	ALL
NI	Q9-60101-633	1	GCCO NG TO LP CONVERSION	GCOD-AP-LP
NI	Y9-80400-14	2	ORIFICE SPUD .0595 #53	GCOD-AP-NAT
NI	2V-80505-10	1	COMBI VALVE	ALL

**IMPORTANT: WHEN ORDERING, SPECIFY VOLTAGE OR TYPE GAS DESIRED  
INCLUDE MODEL AND SERIAL NUMBER**

PAGE 1  
OF 1

Some items are included for illustrative purposes only and in certain instances may not be available.

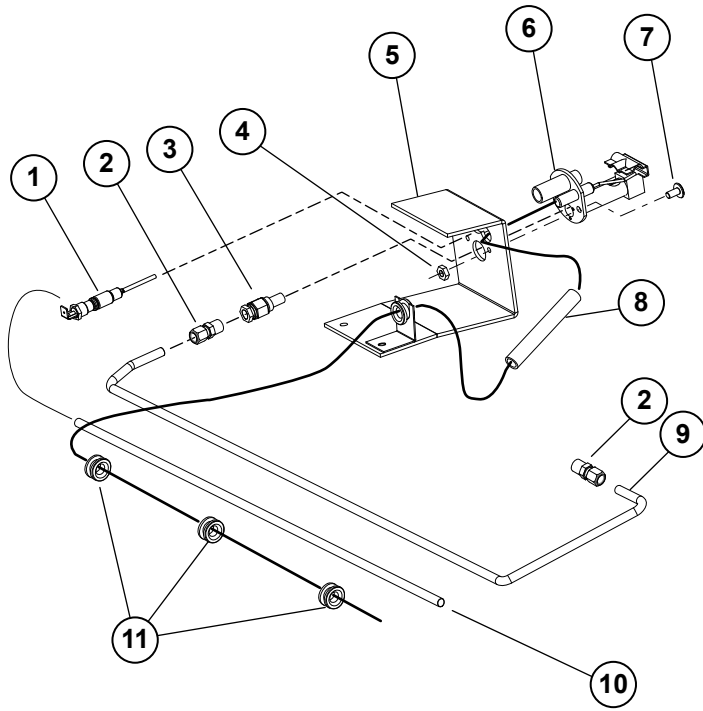

**DETAIL A**  
**Pilot Burner Assembly**

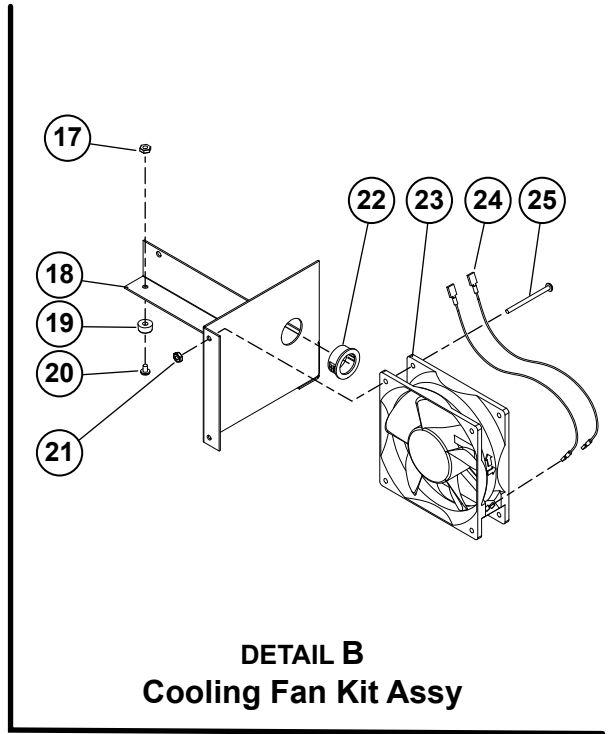

**DETAIL B**  
**Cooling Fan Kit Assy**

**Manifold Assembly**

*Available in Assembly only*

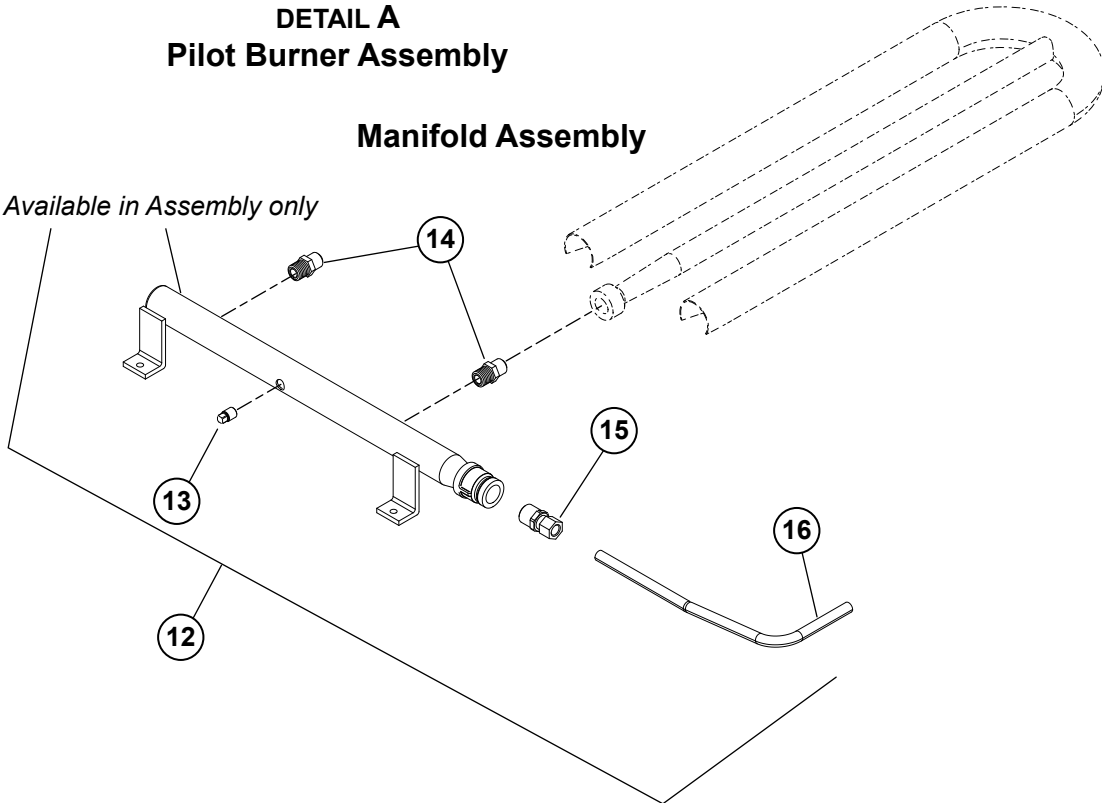

**Model:**  
GCOD/F-NAT & GCOD/F-LP  
Detail A: Gas Convection Oven Pilot & Manifold Assy  
Detail B: GCCO Cooling Fan Kit Assy



# PARTS LIST

October 13, 2014, Rev B

## Model No:GCOD/F-AP-NAT, GCOD/F-AP-LP GAS FULL SIZE CONVECTION OVEN, PILOT BURNER & MANIFOLD ASSEMBLY

Key Number	Part Number	Qty Per	Description
1	<a href="#">2E-41100-07</a>	1	SENSOR FLAME PROBE GCCO ALL
2	<a href="#">2K-70101-32</a>	2	STL TBE UNION 1/2\CCX1/2NPT-M ALL
3	<a href="#">2A-80401-04</a>	1	PLT BURNR ORFCE.021DRL NG GCCO-NAT
	<a href="#">2A-80401-05</a>	1	PLT BURNR ORFCE.010DRL LP GCCO-LP
4	<a href="#">2C-20301-15</a>	2	NUT HEX 10-32 PLTD ALL
5	<a href="#">Q9-GCCO-321</a>	1	JOHNSON PILOT BRACKET ALL
6	<a href="#">2J-80201-14</a>	1	PILOT LT BRNR HRZTL JHNSN ALL
7	<a href="#">2C-20101-24</a>	2	SCRW MS PLT 10-32 X .375 ALL
8	<a href="#">2I-70803-02</a>	1	CERAMIC BUSH 3 TBE ALL
9	<a href="#">Q9-GCCO-322</a>	1	PILOT TUBE ALL
10	<a href="#">1O-71400-13</a>	18 inch.	SLEEVING-PTFE 1/4X .030 ALL
11	<a href="#">2I-70803-04</a>	6	CERMC INSLTR 9/32ID11/16 ALL
12	<a href="#">Q9-GCCO-706</a>	1	MANIFOLD ASSY ALL
13	<a href="#">2K-70308-01</a>	1	PIPE PLUG REG 1/8 NPT BLK ALL
14	<a href="#">Y9-80400-13</a>	2	ORIFICE SPUD .0890 #43 ALL
15	<a href="#">2K-70310-01</a>	1	BELL RDUC 1/2-3/8BLK IRN ALL
16	<a href="#">Q9-GCCO-263-1</a>	1	TUBE 'A' ALL
17	<a href="#">2C-20301-11</a>	2	NUT HEX 8-32 PLTD <a href="#">Q9-60102-171</a> , <a href="#">Q9-60102-1711</a>
18	<a href="#">Q9-GCCO-801</a>	1	GCCO COOLING FAN BRACKET <a href="#">Q9-60102-171</a> , <a href="#">Q9-60102-1711</a>
19	<a href="#">2A-70805-03</a>	2	RBBR BMPT RECESD .25X.50 <a href="#">Q9-60102-171</a> , <a href="#">Q9-60102-1711</a>
20	<a href="#">2C-20101-64</a>	2	SCRW PHD MS M4 X 6 PLTD PHIL <a href="#">Q9-60102-171</a> , <a href="#">Q9-60102-1711</a>
21	<a href="#">2C-20301-10</a>	2	NUT HEX 6-32 PLTD <a href="#">Q9-60102-171</a> , <a href="#">Q9-60102-1711</a>
22	<a href="#">2K-70801-09</a>	1	SNAP BUSH 1 SB1000-12 <a href="#">Q9-60102-171</a> , <a href="#">Q9-60102-1711</a>
23	<a href="#">2U-30200-45</a>	1	MOTOR W/FAN AXIAL 115VAC 70 C <a href="#">Q9-60102-171</a>
	<a href="#">2U-30200-46</a>	1	MOTOR W/FAN AXIAL 220VAC 70 C <a href="#">Q9-60102-1711</a>
24	<a href="#">Q9-GCCO-802</a>	2	HARNESS OVEN <a href="#">Q9-60102-171</a> , <a href="#">Q9-60102-1711</a>
25	<a href="#">2C-20109-14</a>	2	SCRW S/S 6-32 X 2 R/H M/S <a href="#">Q9-60102-171</a> , <a href="#">Q9-60102-1711</a>
NI	<a href="#">2V-80505-11</a>	1	CONVERSION KIT NG TO LP GCCO-AP-LP

**IMPORTANT: WHEN ORDERING, SPECIFY VOLTAGE OR TYPE GAS DESIRED  
INCLUDE MODEL AND SERIAL NUMBER**

PAGE 1  
OF 1

Some items are included for illustrative purposes only and in certain instances may not be available.



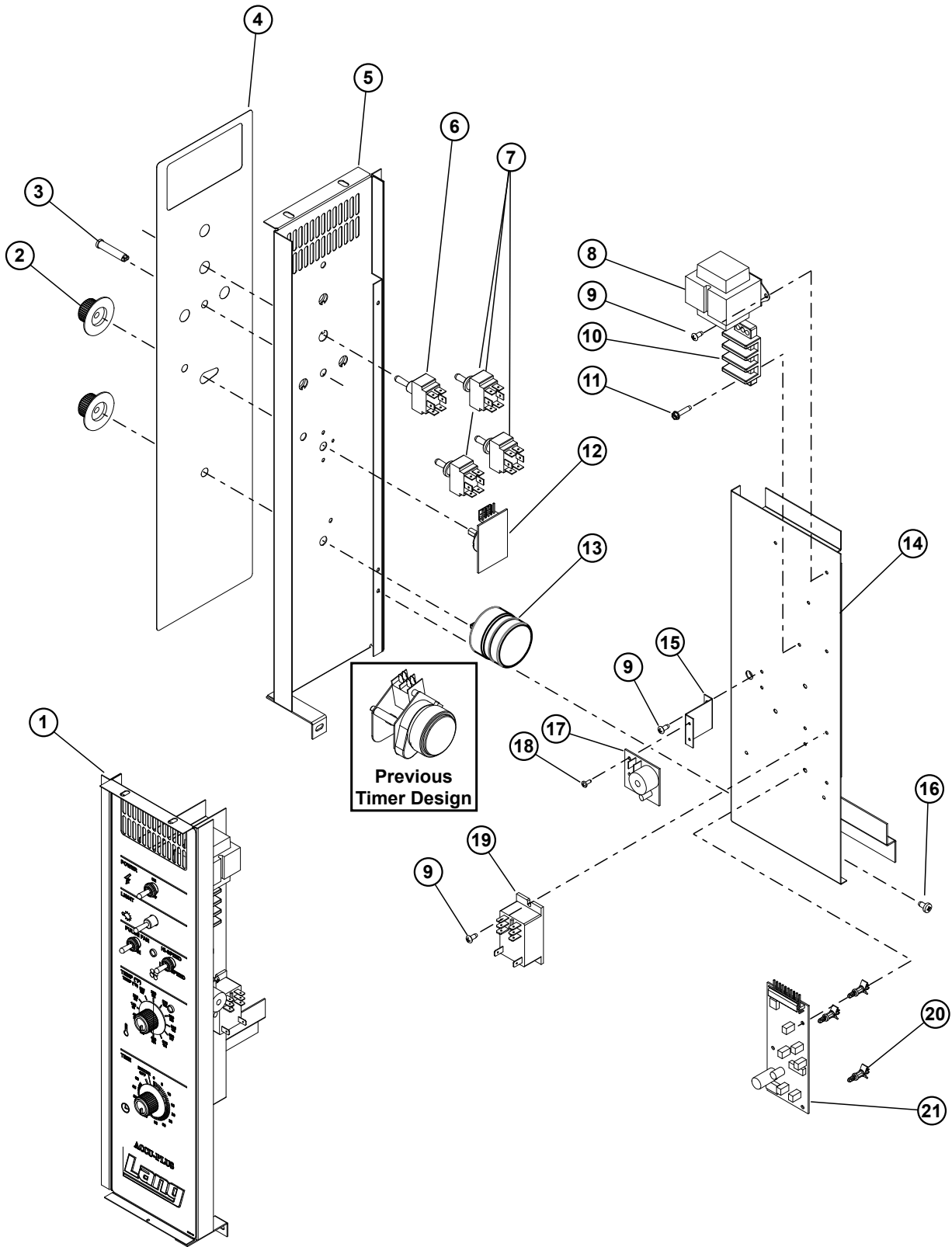

SOME ITEMS ARE INCLUDED FOR ILLUSTRATIVE PURPOSES ONLY AND IN CERTAIN INSTANCES MAY NOT BE AVAILABLE

### Detail C, GCCOPAP Control Panel Detail

GCCO-AP, GCOF-AP, GCOD-AP

# Lang®

SK2386

Rev. A

11/12/2010

# PARTS LIST

October 13, 2014, Rev B

**Model No:GCOD/F-AP-NAT, GCOD/F-AP-LP  
GAS FULL SIZE CONVECTION OVEN, CONTROL PANEL ASSY**

Key Number	Part Number	Qty Per	Description
1	Q9-GCCOPAP	1	PANEL GCCO ACCU-PLUS
2	2R-70701-28	2	KNB BLK 1/4BUSH2SETSCW@90
3	2J-31601-07	2	PILOT LT 28V 6 LEAD WHT
4	2M-60301-100	1	PANEL LABEL-
5	Q9-50312-13	1	CONTROL FRONT T & AP
6	2E-30303-16	1	SWT TOG ON-ON BLK MOM
7	2E-30303-06	3	SWT TOG ON-ON DPDT BLK
8	2E-31400-07	1	XFORMR120-208-240/24V40VA
9	2C-20102-08	9	SCRW PHD ST 8-32X.375
10	2E-30501-02	1	TRM STRP 3 POLE W/PUSH ON
11	2C-20102-05	2	SCRW HXHD ST 8-32X.75
12	2E-30304-16	1	CIR.BD.SWITCH 140'-450'F
13	PS-60101-W4	1	ELEC. TIMER KIT, 1HR-24V
14	Q9-GCCO-350-3	1	SPOT COMPNT MT GCCO
15	Q9-GCCO-355	1	BUZZER BOARD MOUNT
16	2C-20102-12	2	SCRW PHD ST 10-32X3/8
17	2J-30802-04	1	BUZZER ELEC 24V AC PIEZIO
18	2C-20103-06	2	SCRW SM PLT 6 X 3/8 PHL
19	2E-30701-05	1	RELAY 2POLE 30A 24VAC P &
20	2K-70801-07	3	SPACER SUPPORT 1/2LG
21	2E-40101-W19	1	CIRBD SI TEMP CNTRL NO
NI	2E-41100-08	1	SENSOR ECCO/GCCO TEMP
NI	2J-80300-08	1	SPRK IGN CNTRL GCCO CHANNEL NG

**IMPORTANT: WHEN ORDERING, SPECIFY VOLTAGE OR TYPE GAS DESIRED  
INCLUDE MODEL AND SERIAL NUMBER**

PAGE 1  
OF 1

Some items are included for illustrative purposes only and in certain instances may not be available.

