

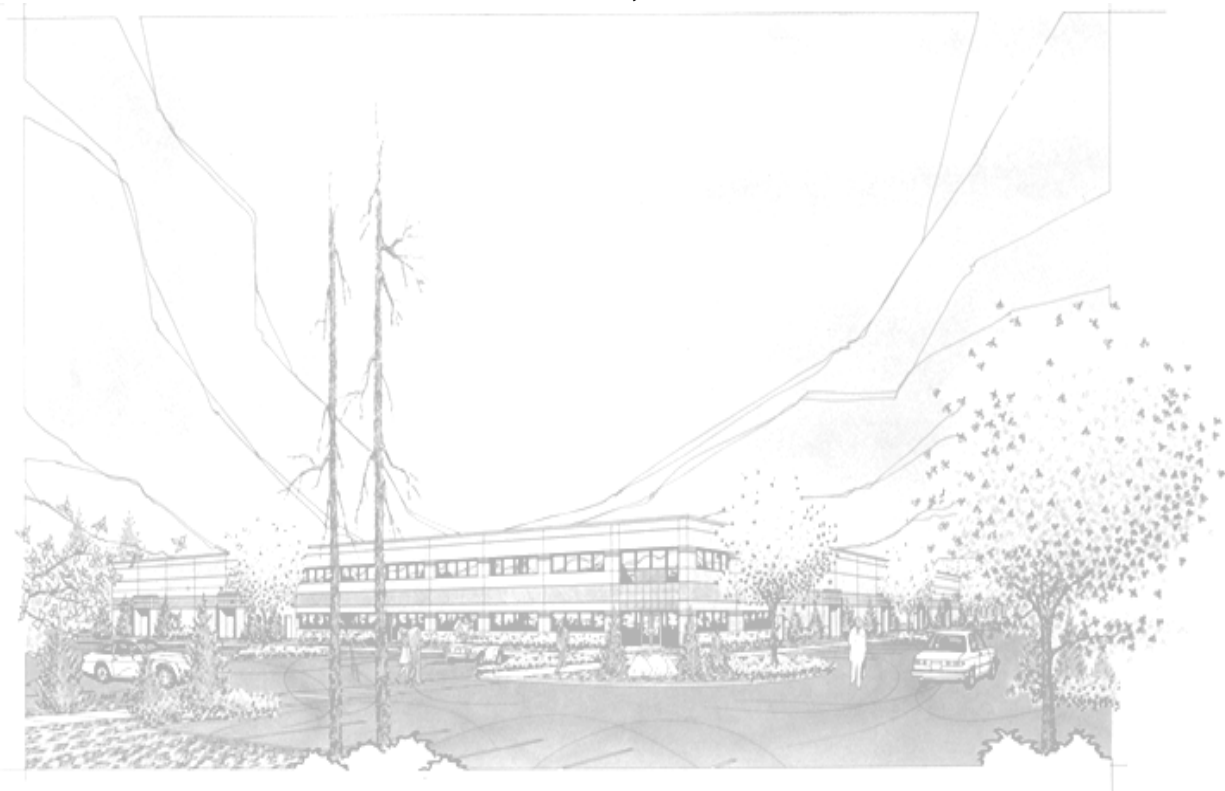





Installation, Operation, Maintenance, & Troubleshooting Model: LGD, Drop-In Griddle



THE INFORMATION IN THIS MANUAL IS CRUCIAL AND MUST BE RETAINED FOR FUTURE REFERENCE. READ, UNDERSTAND AND FOLLOW THE INSTRUCTIONS AND WARNINGS CONTAINED IN THIS MANUAL.

<u>DANGER</u>	POTENTIALLY HAZARDOUS SITUATION WHICH, IF NOT AVOIDED, COULD RESULT IN DEATH.	
<u>WARNING</u>	POTENTIALLY HAZARDOUS SITUATION WHICH, IF NOT AVOIDED, COULD RESULT IN DEATH OR SERIOUS INJURY.	
<u>CAUTION</u>	POTENTIALLY HAZARDOUS SITUATION WHICH, IF NOT AVOIDED, MAY RESULT IN MINOR OR MODERATE INJURY.	
<u>NOTICE</u>	Helpful operation and installation instructions and tips are present.	

FOR YOUR SAFETY

DO NOT STORE OR USE GASOLINE OR OTHER FLAMMABLE VAPORS AND LIQUIDS IN THE VICINITY OF THIS OR ANY OTHER APPLIANCE.

WARNING: IMPROPER INSTALLATION, ADJUSTMENT, ALTERATION, SERVICE OR MAINTENANCE CAN CAUSE PROPERTY DAMAGE, INJURY OR DEATH. READ THE INSTALLATION, OPERATING AND MAINTENANCE INSTRUCTIONS THOROUGHLY BEFORE INSTALLING OR SERVICING THIS EQUIPMENT.

Model #:	Purchased From:
Serial #:	Location:
Date Purchased:	Date Installed:
Purchase Order #:	For Service, Call:

TABLE OF CONTENTS

CHAPTER	PAGE
1. TABLE OF CONTENTS	3
2. READ FIRST	4
3. EQUIPMENT DESCRIPTION	6
4. UNPACKING	6
5. INSTALLATION	7
6. INITIAL START-UP	13
7. OPERATION	14
8. CLEANING & MAINTENANCE PROCEDURES.....	15
9. TROUBLESHOOTING	16
10. PARTS LISTS.....	17
11. WIRING DIAGRAMS.....	18
12. WARRANTY	21

IMPORTANT**READ FIRST****IMPORTANT****CAUTION**

THE GRIDDLE IS EXTREMELY HEAVY. FOR SAFE HANDLING, INSTALLER SHOULD OBTAIN HELP AS NEEDED, OR EMPLOY APPROPRIATE MATERIALS HANDLING EQUIPMENT (SUCH AS A FORKLIFT, DOLLY, OR PALLET JACK) TO REMOVE THE UNIT FROM THE SKID AND MOVE IT TO THE PLACE OF INSTALLATION.

**CAUTION**

ANY STAND, COUNTER OR OTHER DEVICE ON WHICH GRIDDLE WILL BE LOCATED MUST BE DESIGNED TO SUPPORT THE WEIGHT OF THE GRIDDLE.

**CAUTION**

SHIPPING STRAPS ARE UNDER TENSION AND CAN SNAP BACK WHEN CUT.

**DANGER**

THIS APPLIANCE MUST BE GROUNDED AT THE TERMINAL PROVIDED. FAILURE TO GROUND THE APPLIANCE COULD RESULT IN ELECTROCUTION AND DEATH.

**WARNING**

INSTALLATION OF THE UNIT MUST BE DONE BY PERSONNEL QUALIFIED TO WORK WITH ELECTRICITY. IMPROPER INSTALLATION CAN CAUSE INJURY TO PERSONNEL AND/OR DAMAGE TO EQUIPMENT. UNIT MUST BE INSTALLED IN ACCORDANCE WITH ALL APPLICABLE CODES.

**NOTICE**

The data plate is on top of the control box. The griddle voltage, wattage, serial number, wire size, and clearance specifications are on the data plate. This information should be carefully read and understood before proceeding with the installation.

**NOTICE**

The installation of any components such as a vent hood, grease extractors, fire extinguisher systems, must conform to their applicable National, State and locally recognized installation standards.

**CAUTION**

BE SURE THE POWER SUPPLY VOLTAGE MATCHES THE VOLTAGE SPECIFIED ON THE NAMEPLATE LOCATED ON THE TOP OF THE CONTROL BOX

**NOTICE**

During the first few hours of operation you may notice a small amount of smoke coming off the unit, and a faint odor from the smoke. This is normal for a new griddle and will disappear after the first few hours of use.

**CAUTION**

ALWAYS KEEP THE AREA NEAR THE APPLIANCE FREE FROM COMBUSTIBLE MATERIALS.

**CAUTION**

KEEP FLOOR IN FRONT OF EQUIPMENT CLEAN AND DRY. IF SPILLS OCCUR, CLEAN IMMEDIATELY, TO AVOID THE DANGER OF SLIPS OR FALLS.

**NOTICE**

The times and temperatures in this chart are intended as a general guide and starting point. Your actual times and temperatures may vary from this chart.

**WARNING**

KEEP WATER AND SOLUTIONS OUT OF CONTROLS. NEVER SPRAY OR HOSE CONTROL CONSOLE, ELECTRICAL CONNECTIONS, ETC.

**CAUTION**

MOST CLEANERS ARE HARMFUL TO THE SKIN, EYES, MUCOUS MEMBRANES AND CLOTHING. PRECAUTIONS SHOULD BE TAKEN TO WEAR RUBBER GLOVES, GOGGLES OR FACE SHIELD AND PROTECTIVE CLOTHING. CAREFULLY READ THE WARNING AND FOLLOW THE DIRECTIONS ON THE LABEL OF THE CLEANER TO BE USED.



NOTICE

Any cleaner used should be marked: "SAFE ON ALUMINUM".

**NOTICE**

Service on this, or any other, LANG appliance must be performed by qualified personnel only. Consult your authorized service station directory or call the factory at 1-800-224-LANG (5264), or WWW.LANGWORLD.COM For the service station nearest you.

**WARNING**

BOTH HIGH AND LOW VOLTAGES ARE PRESENT INSIDE THIS APPLIANCE WHEN THE UNIT IS PLUGGED/WIRED INTO A LIVE RECEPTACLE. BEFORE REPLACING ANY PARTS, DISCONNECT THE UNIT FROM THE ELECTRIC POWER SUPPLY.

**CAUTION**

USE OF ANY REPLACEMENT PARTS OTHER THAN THOSE SUPPLIED BY LANG OR THEIR AUTHORIZED DISTRIBUTORS CAN CAUSE BODILY INJURY TO THE OPERATOR AND DAMAGE TO THE EQUIPMENT AND WILL VOID ALL WARRANTIES.



EQUIPMENT DESCRIPTION

Lang Model: LGD Electric Drop-In Griddle

Exterior

The Griddle dimensions are 26" (66cm) Deep, 5 3/8" (13.65cm) High, and width is dependent on model number.

The griddle surface is constructed of 1" thick highly polished steel to reduce hot and cold spots, recovery problems, and ensured even heat through out the griddle.

Controls

Each twelve-inch section has its own easy to use manual thermostat with a temperature range from 175°F to 450°F in 25° increments.

Each twelve-inch section has a set of 6 kW elements for high efficiency, quick recovery and outstanding performance.

UNPACKING

Receiving the Griddle

Upon receipt, check for freight damage, both visible and concealed. Visible damage should be noted on the freight bill at the time of delivery and signed by the carrier's agent.

Concealed loss or damage means loss or damage, which does not become apparent until the merchandise has been unpacked. If concealed loss or damage is discovered upon unpacking, make a written request for inspection by the carrier's agent within 15 days of delivery. All packing material should be kept for inspection. Do not return damaged merchandise to Lang Manufacturing Company. File your claim with the carrier.

Location

Prior to un-crating, move the griddle as near its intended location as practical. The crating will help protect the unit from the physical damage normally associated with moving it through hallways and doorways.

Un-crating

The griddle will arrive completely assembled inside a wood frame covered by cardboard box and strapped to a skid. **Remove the cardboard cover, cut the straps and remove the wood frame.**

CAUTION THE GRIDDLE IS EXTREMELY HEAVY. FOR SAFE HANDLING, INSTALLER SHOULD OBTAIN HELP AS NEEDED, OR EMPLOY APPROPRIATE MATERIALS HANDLING EQUIPMENT (SUCH AS A FORKLIFT, DOLLY, OR PALLET JACK) TO REMOVE THE UNIT FROM THE SKID AND MOVE IT TO THE PLACE OF INSTALLATION.



CAUTION ANY STAND, COUNTER OR OTHER DEVICE ON WHICH GRIDDLE WILL BE LOCATED MUST BE DESIGNED TO SUPPORT THE WEIGHT OF THE GRIDDLE.



CAUTION SHIPPING STRAPS ARE UNDER TENSION AND CAN SNAP BACK WHEN CUT.



Remove griddle from skid and place in intended location.

INSTALLATION

DANGER THIS APPLIANCE MUST BE GROUNDED AT THE TERMINAL PROVIDED. FAILURE TO GROUND THE APPLIANCE COULD RESULT IN ELECTROCUTION AND DEATH.



WARNING INSTALLATION OF THE UNIT MUST BE DONE BY PERSONNEL QUALIFIED TO WORK WITH ELECTRICITY. IMPROPER INSTALLATION CAN CAUSE INJURY TO PERSONNEL AND/OR DAMAGE TO EQUIPMENT. UNIT MUST BE INSTALLED IN ACCORDANCE WITH ALL APPLICABLE CODES.



NOTICE The data plate is on top of the control box. The griddle voltage, wattage, serial number, wire size, and clearance specifications are on the data plate. This information should be carefully read and understood before proceeding with the installation.



NOTICE The installation of any components such as a vent hood, grease extractors, fire extinguisher systems, must conform to their applicable National, State and locally recognized installation standards.



Cabinet Preparation

Cabinet Base must have cross air ventilation. It does not matter if it is on the ends or sides.

If vents are not installed, the controls may overheat rendering the griddle inoperative.

For best results provide a knockout for the control panel a minimum of 4½ inches away from the griddle support surface as shown on next page.

Installing Griddle into Cabinet

Turn the griddle over, taking care not to kink the thermostat capillary tubes.

Set the griddle on the table that it is to be installed in (leaving a hole big enough to slip the control panel through).

Insert the control panel through the hole and out the control opening of the cabinet.

The hole must be such that the control box can come out of the cabinet 18" for serviceability.

Lower the griddle plate to sit flat in the table opening.

Electrical Connection

The electrical connection must be made in accordance with local codes or in the absence of local codes with **NFPA No. 70**; latest edition (in Canada use: **CSA STD. C22.1**).

A power connection box is provided for power connection.

This box must be installed a minimum of 18 inches away from the heating elements in the cabinet box.

All electrical connections can be made at this box.

The griddle can now be connected to power.

CAUTION BE SURE THE POWER SUPPLY VOLTAGE MATCHES THE VOLTAGE SPECIFIED ON THE NAMEPLATE LOCATED ON THE TOP OF THE CONTROL BOX



LGD24 Cabinet Cut-out

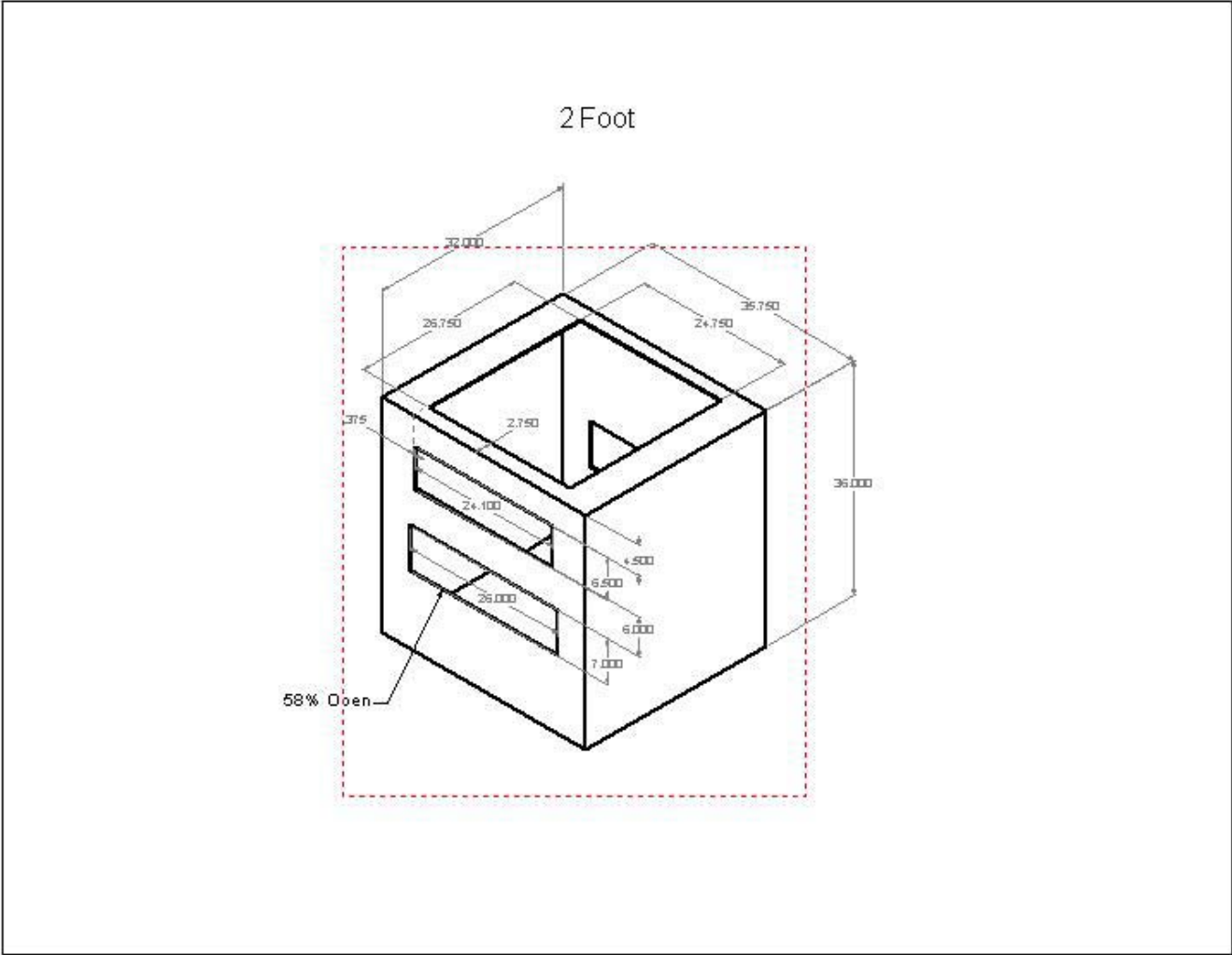

LGD36 Cabinet Cut-out

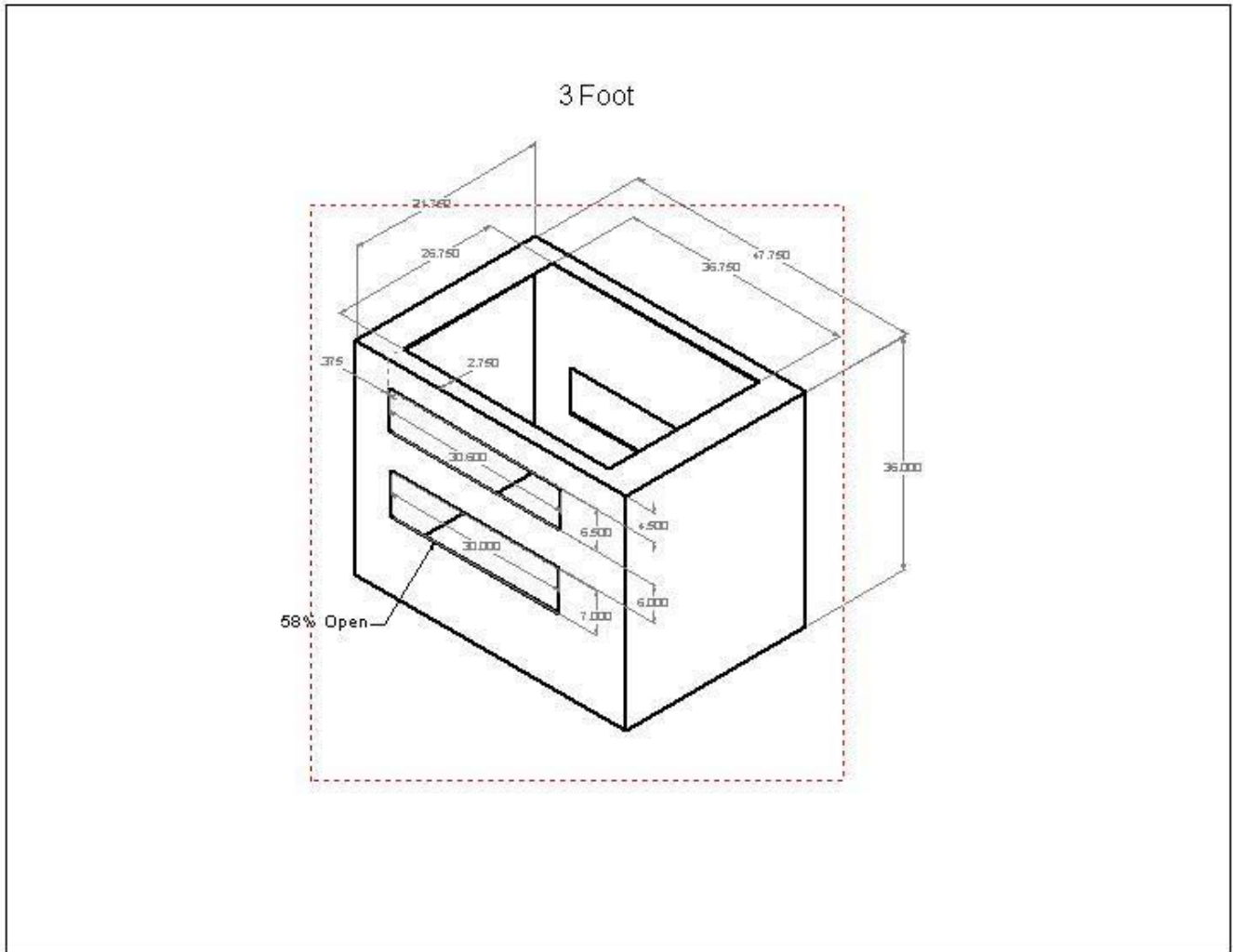

LGD48 Cabinet Cut-out

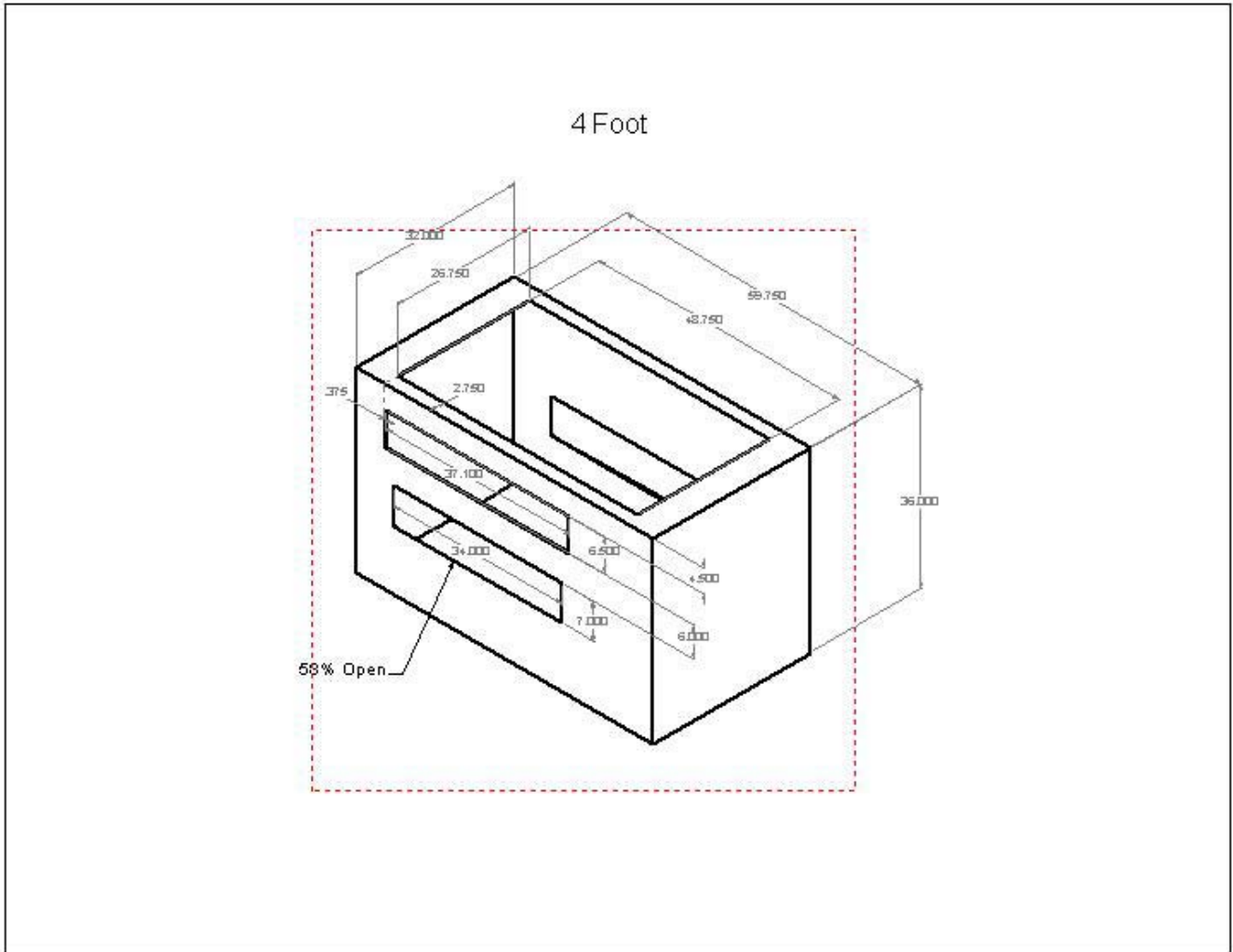

LGD72 Cabinet Cut-out

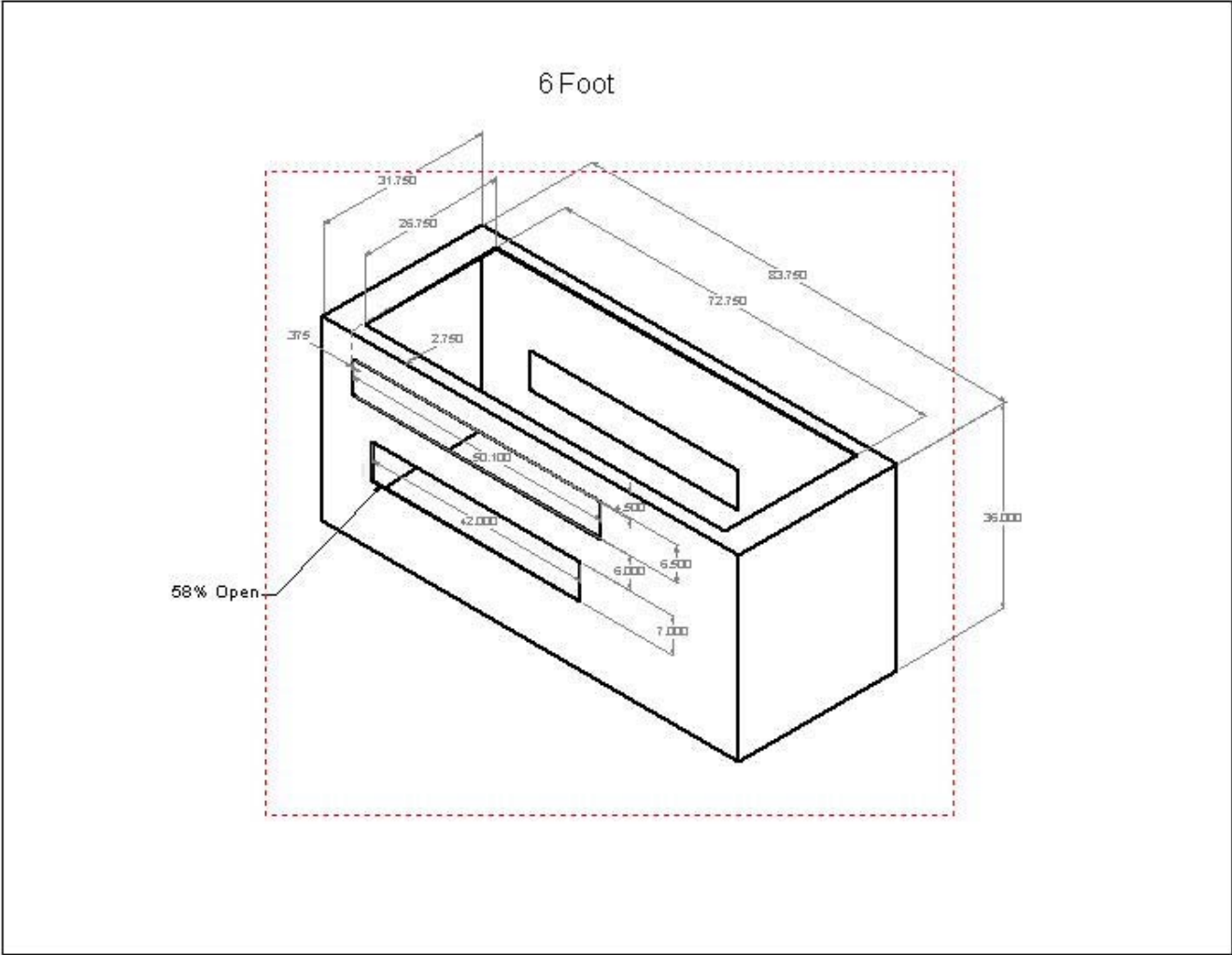

INITIAL START UP

NOTICE

During the first few hours of operation you may notice a small amount of smoke coming off the unit, and a faint odor from the smoke. This is normal for a new griddle and will disappear after the first few hours of use.



Pre-Power On

Before turning the griddle on verify all electrical connections and remove excess shipping grease from the griddle surface.

Power On

Set the temperature dials to 200°F.

Heat the griddle at 200°F for 2 hours to evaporate any moisture that may be in the elements.

After 2 hours at 200°F, turn the griddle temperature up to 350°F for ½ hour.

After the griddle reaches 350°F for ½ hour, turn the griddle up another 50°F for another ½ hour and repeat this until the griddle is at 450°F for ½ hour

The griddle may emit a small amount of smoke as the cooking surface passes the 300°F point. Do not be alarmed as the smoke is caused by oils associated with the manufacturing process and will stop when the griddle reaches 350°F.

Seasoning Cooking Surface

The cooking surface must be "seasoned" in order to eliminate product sticking during cooking.

To season, heat the griddle to 250°F.

Once at 250°F, coat the cooking surface with non-salted vegetable oil.

Allow the griddle to stand at 250°F until the cooking surface looks dry then coat it again.

Heat the griddle to 350°F and repeat the procedure.

OPERATION

CAUTION ALWAYS KEEP THE AREA NEAR THE APPLIANCE FREE FROM COMBUSTIBLE MATERIALS.



CAUTION KEEP FLOOR IN FRONT OF EQUIPMENT CLEAN AND DRY. IF SPILLS OCCUR, CLEAN IMMEDIATELY, TO AVOID THE DANGER OF SLIPS OR FALLS.



An understanding of how the griddle sections are controlled will be a valuable aid in loading your griddle.

Each 12-inch section of your griddle is independently controlled by a temperature thermostat. The thermostat sensor is mounted in the center of each cooking section under the griddle plate.

If the product is loaded directly over the thermostat sensor, that section will turn on and the element will heat the entire cooking section. If the product is loaded to the side, front or back of the temperature sensor, the thermostat will react to the temperature change much slower.

During slow periods with minimal loads, do not load directly over the thermostat sensors as this will unnecessarily turn the burners on and overheat the remainder of the section not being utilized.

Turn the product and continue cooking until it has reached its desired degree of doneness.

Remove the product from the griddle.

When reloading the griddle, first use the griddle surface on which a previous load was not placed. This will help insure the proper griddle temperature.

MAINTENANCE & CLEANING

WARNING

KEEP WATER AND SOLUTIONS OUT OF CONTROLS. NEVER SPRAY OR HOSE CONTROL CONSOLE, ELECTRICAL CONNECTIONS, ETC.



CAUTION

MOST CLEANERS ARE HARMFUL TO THE SKIN, EYES, MUCOUS MEMBRANES AND CLOTHING. PRECAUTIONS SHOULD BE TAKEN TO WEAR RUBBER GLOVES, GOGGLES OR FACE SHIELD AND PROTECTIVE CLOTHING. CAREFULLY READ THE WARNING AND FOLLOW THE DIRECTIONS ON THE LABEL OF THE CLEANER TO BE USED.



NOTICE

Any cleaner used should be marked: "SAFE ON ALUMINUM".



Cleaning

The griddle should be thoroughly cleaned at least once a week in addition to the normal daily cleaning to insure against the accumulation of foreign material.

Electric equipment is inherently clean and sanitary, but may become unsanitary if dirt is allowed to accumulate on it. Take advantage of the clean, sanitary features of electric equipment, give it the regular attention that it deserves the same as any other highly perfected machinery, to insure best results and continued high operating efficiency.

Always start with a cold griddle.

Always follow the cleaner manufacturer's instructions when using any cleaner.

Griddle surface may be cleaned using Lang Mfg. Carbon Release ([72804-32](#)) cleaner.

Always apply these cleaners when the griddle is cold and rub in the direction of the metal's grain.

CALIBRATION

Calibration Check

Place thermometer or thermocouple in the center of griddle directly over the sensor.

Set thermostat to 350°.

Allow the griddle to Preheat for at least half an hour.

Note cycle "ON" temperatures and cycle "OFF" temperatures for 3 cycles. (Red indicator light indicates when the griddle is calling for heat)

After 3 cycles average the temperature. (Add all six temperatures and divide by 6).

The temp should be +/- 10°F

Calibration Adjustment

A 1/16" flat blade screwdriver with a 2" shaft is required to make adjustments on the thermostat.

Maintain the griddle temperature at 350°.

Without turning the thermostat, remove the knob.

Locate the adjustment screw at the base of the shaft and insert the screwdriver.

Grasp the shaft and turn the screwdriver. Counter clockwise to increase and clockwise to decrease (1/8 of a turn will move the temperature 5-7 ° in either direction).

Reinstall the thermostat knob and recheck the griddle temperature.

Symptoms

What follows is a chart of Symptoms, Possible Causes, and Remedy's to aid in diagnosing faults with the griddle.

Refer to the Symptoms column to locate the type of failure then to the Possible Cause for the items to be checked and the Remedy to column for possible solutions.

SYMPTOM	POSSIBLE CAUSE
Griddle will not heat	<ul style="list-style-type: none"> • No power to Unit • Defective thermostat • Defective element
Product is under cooked	<ul style="list-style-type: none"> • No power to griddle • Thermostat out of calibration • Defective thermostat
Product is burning	<ul style="list-style-type: none"> • Thermostat out of calibration • Defective thermostat

NOTICE

Service on this, or any other, LANG appliance must be performed by qualified personnel only. Consult your authorized service station directory or call the factory at 1-800-224-LANG (5264), or WWW.LANGWORLD.COM For the service station nearest you.



WARNING

BOTH HIGH AND LOW VOLTAGES ARE PRESENT INSIDE THIS APPLIANCE WHEN THE UNIT IS PLUGGED/WIRED INTO A LIVE RECEPTACLE. BEFORE REPLACING ANY PARTS, DISCONNECT THE UNIT FROM THE ELECTRIC POWER SUPPLY.



TESTS

If an item on the list is followed by an asterisk (*), the work should be done by a factory authorized service representative.

POSSIBLE CAUSE	TEST
Product is cooked too long	<ul style="list-style-type: none"> • No test available, operational condition
Failed thermostat	<ul style="list-style-type: none"> • Verify calibration • Replace thermostat*
Failed element	<ul style="list-style-type: none"> • Remove the wires and check for continuity across the element * • Replace element*

CAUTION

USE OF ANY REPLACEMENT PARTS OTHER THAN THOSE SUPPLIED BY LANG OR THEIR AUTHORIZED DISTRIBUTORS CAN CAUSE BODILY INJURY TO THE OPERATOR AND DAMAGE TO THE EQUIPMENT AND WILL VOID ALL WARRANTIES.



PARTS LIST

DESCRIPTION	PART NO.
Griddle Element 208 / 240-Volt O/S 4500 Watts / 6000 Watts	11030-29
Griddle Element 208-Volt I/S 1491 Watts	11030-30
Griddle Element 480-Volt 5991 Watts	11030-31
Thermostat 450° F	30402-08
Thermostat 550° F	30402-07
Knob Thermostat 450°F	70701-19
Knob Thermostat 550°F	70701-15
Indicator Lamp 240-Volt	31601-01
Indicator Lamp 480-Volt	31601-02
Terminal Strip, 4-Pole	30500-02
Terminal Strip, 6-Pole	30500-03
Terminal Strip, 8-Pole	30500-05
Terminal Block 3-Pole	30500-09
Grooved Griddle Cleaning Tool	50100-05
Grooved Griddle Cleaning Tool, Replacement Fingers	50100-051
Grooved Griddle Cleaning Tool, Replacement Blades	50100-052
Element Pan Assembly	50302-05

WIRING DIAGRAM 208/240- VOLT

Revision Block					
REV	ECN NO.	DESCRIPTION	DR.	MFG.	ENG.
E		REVISED AND REDRAWN	CDS		10/15/2002
F		ADDED 220VAC FOR LGCL	DLG		12/13/2002

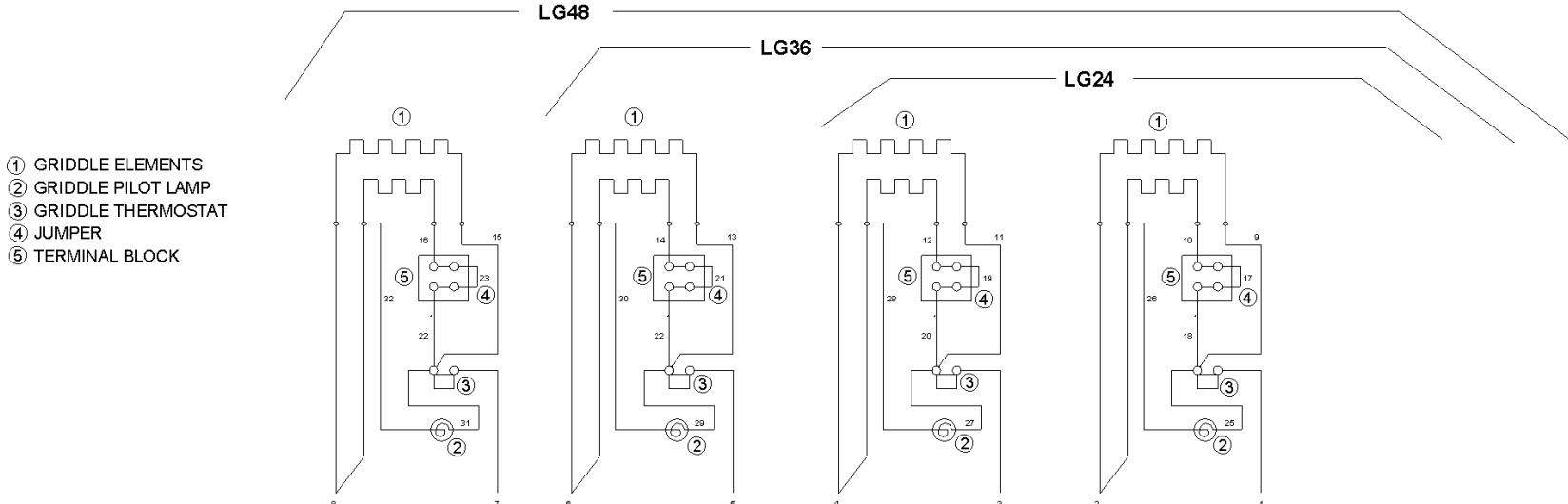

- ① GRIDDLE ELEMENTS
- ② GRIDDLE PILOT LAMP
- ③ GRIDDLE THERMOSTAT
- ④ JUMPER
- ⑤ TERMINAL BLOCK

NOTES:

- LG60 & LG72 HAVE TWO POWER SUPPLY CONNECTIONS
- LG60: CONN #1 USE LG36
CONN #2 USE LG24
- LG72: CONN #1 USE LG36
CONN #2 USE LG36

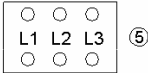

ELEMENT HOOKUP	
208-220 V	240V
INSTALL JUMPER (ITEM 4)	REMOVE JUMPER (ITEM 4)

MODEL	VOLT	Kw				AMP TOTALS			AMPS 1 PHASE	THREE PHASE			SINGLE PHASE	
		L1-L2	L2-L3	L1-L3	TOTAL	L1	L2	L3		L1	L2	L3	L1	L2
		LG24	208	6.0		6.0	12.0	50.0	28.9	28.9	57.7	1.4	2	3
	220	6.7		6.7	13.4	52.9	30.5	30.5	60.9					
	240	6.0		6.0	12.0	43.3	25.0	25.0	50					
LG36	208	6.0	6.0	6.0	18.0	50.0	50.0	50.0	86.5	1.4	2.5	3.6	1,3,5	2,4,6
	220	6.7	6.7	6.7	20.1	52.9	52.9	52.9	91.4					
	240	6.0	6.0	6.0	18.0	43.3	43.3	43.3	75					
LG48	208	12.0	6.0	6.0	24.0	76.0	76.3	50.0	115.4	1.4,7	2.5,8	3.6	1,3,5,7	2,4,6,8
	220	13.4	6.7	6.7	26.8	80.6	80.6	52.9	121.8					
	240	12.0	6.0	6.0	24.0	66.1	66.1	43.3	100					

Lang Manufacturing Company	DWN. BY: DLG	DWN. DATE: 12-13-02	REV. BY:	REV. DATE:	CHK. BY:	CHK. DATE:
	DESCRIPTION: LANG GRIDDLE 208-240/220VAC					
CAD FILE: FROM ACAD		DWG. NO: 61114-01		SHEET 1 OF 1		REV: F

WIRING DIAGRAM 480 VOLT

Revision Block						
REV	ECN NO.	DESCRIPTION	DR.	MFG.	ENG.	DATE
C		REVISED AND REDRAWN	CDS			10/15/2002

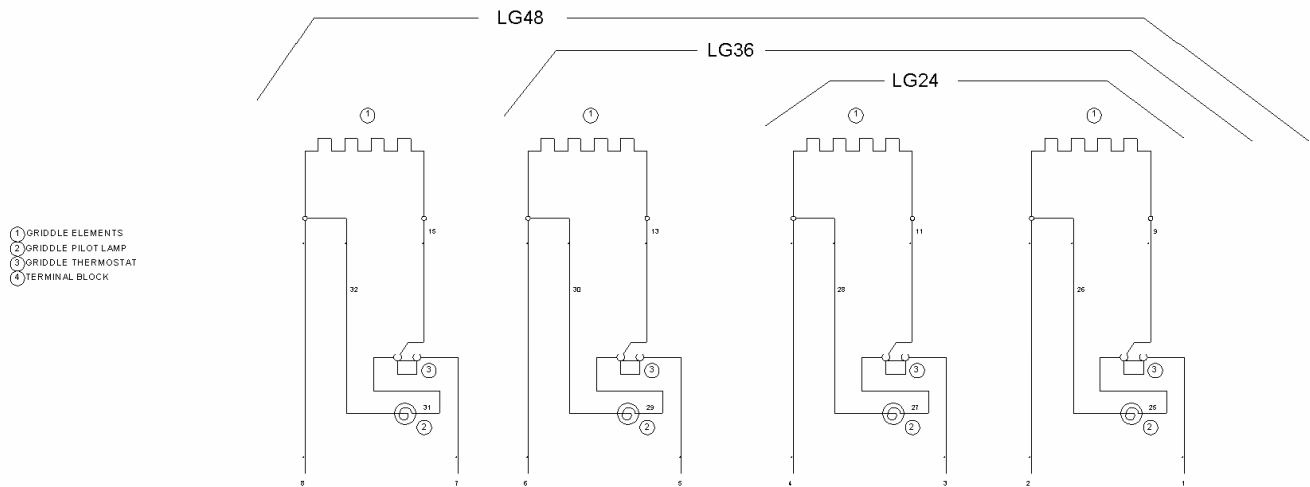

NOTE: LG60 & LG72 HAVE TWO POWER SUPPLY CONNECTIONS

LG60: CONN # 1 USE LG36
 CONN # 2 USE LG24
 LG72: CONN # 1 USE LG36
 CONN # 2 USE LG36

SERVICE CONNECTIONS			
MODEL	THREE PHASE		
	L1	L2	L3
24	1,4	2	3
36	1,4	2,5	3,6
48	1,4,7	2,5,8	3,6

* NUMBER

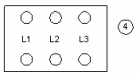

AMP TOTAL			
Model	L1	L2	L3
24	22	13	13
36	22	22	22
48	33	33	22
60	43	33	33
72	43	43	43

	UNLESS OTHERWISE SPECIFIED DIMENSIONS ARE IN INCHES.	MATERIAL PART # :	MATERIAL TYPE :	BLANK DIMS. : X	BLANK AREA:	sq in
	TOLERANCES ARE: DECIMALS ANGLES X = ± .05 ±.5° XX = ± .03 XXX = ± .015	DWN. BY: CDS / DWN. DATE: 10/15/02 / REV. BY: / REV. DATE: / CHK. BY: / CHK. DATE: / CAD FILE: / SHEET 1 OF 1				
	DESCRIPTION: LANG GRIDDLE 480VAC ACCUTEMP					DWG. NO: 61114-02