

SERVICE MANUAL

(INTERNATIONAL)

IMPINGER CONVEYOR OVENS

MODEL 1100 SERIES



Lincoln Foodservice Products, Inc.
1111 North Hadley Road
Fort Wayne, Indiana USA 46804
United States of America

Phone: (800) 374-3004 • Fax: (260) 436-0735

Technical Service Hot Line
(800) 678-9511

www.lincolnfp.com

TABLE OF CONTENTS

SEQUENCE OF OPERATIONS 1104 THRU 1106.....	3-4
SEQUENCE OF OPERATIONS 1134, 1135, 1136, 1150.....	5-6
SEQUENCE OF OPERATIONS 1151.....	7-8
SEQUENCE OF OPERATIONS 1152 THRU 1158.....	9-11
SCHEMATIC 1104, 1105.....	12
SCHEMATIC 1106	13
SCHEMATIC 1134, 1135, 1150 S/N 2011383 & BELOW.....	14
SCHEMATIC 1134, 1135, S/N 2011383 & ABOVE.....	15
SCHEMATIC 1150 S/N 2011373 & ABOVE.....	16
SCHEMATIC 1136, S/N 2011383 & ABOVE.....	17
SCHEMATIC 1136, S/N 20211383 & ABOVE.....	18
SCHEMATIC 1151, S/N 2011383 & BELOW.....	19
SCHEMATIC 1151, S/N 2011373 & ABOVE.....	20
SCHEMATIC 1152 THRU 1158, S/N 2011383 & BELOW.....	21
SCHEMATIC 1152 THRU 1158, S/N 2011383 & ABOVE.....	22
SCHEMATIC 1152 & 1153 S/N 2011821 & ABOVE.....	23
SCHEMATIC 1154 THRU 1158, S/N 2011821 & ABOVE.....	24
TROUBLE SHOOTING GUIDE, GAS OVENS 1152 THRU 1158.....	25-33
TROUBLE SHOOTING GUIDE, ELECTRIC OVENS 1104, 1105, 1106.....	34-36
TROUBLE SHOOTING GUIDE, ELECTRIC OVENS 1134, 1135, 1136, 1150.....	37-40
TROUBLE SHOOTING GUIDE, ELECTRIC OVEN 1151.....	41-46
REMOVAL, INSTALLATION, AND ADJUSTMENTS.....	47-69
GENERAL, PARTS BREAKDOWN.....	70
GENERAL, PARTS BLOW UP.....	71
CONTROL COMPARTMENT FRONT, PARTS BREAKDOWN.....	72
CONTROL COMPARTMENT FRONT, BLOW UP.....	73
CONTROL COMPARTMENT FRONT, 1152 THRU 1158 PARTS BREAKDOWN.....	74
CONTROL COMPARTMENT FRONT, 1152 THRU 1158 BLOW UP.....	75
CONTROL COMPARTMENT REAR, S/N 2011383 & BELOW PARTS.....	76
CONTROL COMPARTMENT REAR, S/N 2011383 & BELOW BLOW UP.....	77
CONTROL COMPARTMENT REAR, S/N 2011383 & ABOVE PARTS.....	78
CONTROL COMPARTMENT REAR, S/N 2011383 & ABOVE BLOW UP.....	79
CONTROL COMPARTMENT REAR, 1152 THRU 1158, S/N 2011821 & BELOW PARTS BREAKDOWN.....	80
CONTROL COMPARTMENT REAR, 1152 THRU 1158, S/N2011821 & BELOW BLOW UP.....	81
CONTROL COMPARTMENT REAR, 1152 THRU 1158, S/N 2011821 & ABOVE PARTS BREAKDOWN.....	82
CONTROL COMPARTMENT REAR, 1152 THRU 1158, S/N2011821 & ABOVE BLOW UP.....	83
OVEN BACK ASSEMBLY PARTS BREAKDOWN.....	84
OVEN BACK ASSEMBLY BLOW UP.....	85
GEARMOTOR ASSEMBLY PARTS BREAKDOWN.....	86
GEARMOTOR ASSEMBLY BLOW UP.....	87
CONVEYOR / DOOR PARTS BREAKDOWN.....	88
CONVEYOR / DOOR BLOW UP.....	89

SEQUENCE OF OPERATIONS 1104 thru 1106

MODEL 1104	ELECTRIC	380/220 VAC	50 HZ	3 PHASE
MODEL 1105	ELECTRIC	415/240 VAC	50 HZ	3 PHASE
MODEL 1106	ELECTRIC	240 VAC	50 HZ	1 PHASE

POWER SUPPLY

Electrical power to be supplied to the oven by a five conductor service on Models 1104 and 1105 and a three conductor service on the 1106.

MAIN FAN CIRCUIT

Power is permanently supplied (through a 10A fuse) to the normally open contact of the main fan relay, the normally open cool-down thermostat and to the normally open main fan switch. Closing the main fan switch supplies line voltage to the primary of the power transformer (The transformer steps the voltage down to 120 VAC for the control circuit). 120 VAC is supplied to the coil of the main fan relay, its normally open contacts now close, energizing the main fan motor. Closing the main fan switch also supplies 120 VAC to the cooling fan and, through a normally closed hi-limit thermostat, the time/temp display, heat and conveyor switches.

HEATER CIRCUIT

Closing the Heater Switch provides power through the normally open Air Pressure Switch through the 3 Amp Fuse, to the Temperature Control Board and to the Heater Lamp.

TEMPERATURE CONTROL

Closing the Heat Switch supplies 120 VAC to the Electronic Temperature Control. The 2.5K ohm Potentiometer is adjusted to achieve the desired temperature. The Thermocouple will provide varying millivolts to the Temperature Control. The temperature control board then supplies 120 VAC to the coil of the Contactor at intermittent intervals to maintain the desired temperature.

NOTE: Units with Serial Number prior to 2000782 were equipped with a Fenwall Temperature Control and used a Temperature Control Potentiometer rated at 5K ohms.

CONVEYOR DRIVE

Closing the Conveyor Switch supplies 120 VAC to the DC Motor Control Board at terminals L1 and L2. A.C.volts are converted to DC volts and are supplied to the Conveyor Motor at terminals A+ and A-. Adjustment of the Speed Control Potentiometer (5,000 ohm, 10 turn) will change resistance at terminals P1, P2, and P3 varying the DC voltage to the Conveyor Motor. The speed of the conveyor motor will increase or decrease as the DC voltage from the board increases or decreases respectively. As the motor turns, it drives both the reducer gear box and the tach. generator. The tach. generator is a DC voltage generator which supplies a voltage to the DC Motor Control Board and is used as a reference for maintaining a constant conveyor speed.

TIME/TEMP DISPLAY

The secondary output of the Transformer, is supplied to terminals 1, 2, and 3 of the Time/Temp. Display. The secondary output of the Transformer is nominally 12. to 15 VAC with a center tap. The voltage from center tap to each leg is 1/2 the secondary voltage. The speed side of the Time/Temp. Display uses a slotted disc (cemented to tach. coupling) to break the infra-red light beam of the optical encoder (mounted on gear motor) producing electrical pulses that are transmitted to the display. The display converts these pulses into a read-out of min. The temperature portion of the Time/Temp Display uses a Thermistor

The temperature portion of the Time/Temp Display uses a Thermistor Probe to sense oven temperature. The thermistor outputs a resistance proportional to the oven temperature. This resistance is then converted by the display into a temperature reading.

AUTOMATIC COOL DOWN

When the oven reaches operating temperature the normally open Oven Cool Down Thermostat closes. After the oven is switched OFF, the Thermostat bypasses the Fan Switch, keeping the Cooling Fan and Main Fan in operation until the oven cools down to approximately 200°F (93.3°C).

SEQUENCE OF OPERATION 1134 - 1135 - 1136 - 1150

MODEL 1134	ELECTRIC	220/380 VAC	50 HZ	3 PHASE
MODEL 1135	ELECTRIC	240/415 VAC	50 HZ	3 PHASE
MODEL 1136	ELECTRIC	240 VAC	50 HZ	1 PHASE
MODEL 1150	ELECTRIC	220/380 VAC	50 HZ	3 PHASE

POWER SUPPLY	Electrical power to be supplied to the oven by a three conductor service on single phase and a five conductor service on three phase.
CONTROL BOX AUTO COOL DOWN	When the temperature in the control box reaches 120°F ± 3°F (48.9°C ± 1.7°C), the Cooling Fan Thermostat closes, switching power to the Cooling Fans. The thermostat will open at 100°F ± 3°F (37.8°C ± 1.7°C) interrupting power to the Cooling Fans.
MAIN FAN CIRCUIT	Power is supplied by Line 1 on Model 1136 and L2 on 1134, 1135, and 1150 to the normally open main fan relay. Power is also supplied from Line 1, through the 1 Amp Fuse to the primary of the Step Down Transformer. 120 V AC is continuously supplied from Transformer secondary to terminal number 1 of the 20 Minute Timer and through the High Limit Thermostat (normally closed) to the Main Fan Switch. Closing the Fan Switch energizes the coil of the oven start relay, its contacts close enabling the 20 minute time delay module. The 20 minute time delay module supplies 120 VAC to the oven fan relay, this normally open contact now closes supplying line voltage to the main fan motor. The cooling fans and the time/temp display transformer are also energized.
HEATING CIRCUIT	Closing the Heat Switch supplies 120 volts AC through the normally open Air Pressure Switch (closed by air pressure from the Main Fan), the 3 Amp Fuse, to terminal L1 of the Temperature Control Board, and the Heat Indicator Light.
TEMPERATURE CONTROL	Closing the Heat Switch supplies 120 VAC to the Electronic Temperature Control. The 2.5K ohm Potentiometer is adjusted to achieve the desired temperature. The Thermocouple will provide varying millivolts to the Temperature Control. The temperature control board then supplies 120 VAC to the coil of the Contactor at intermittent intervals to maintain the desired temperature.
CONVEYOR DRIVE	Closing the Conveyor Switch supplies 120 VAC to the DC Motor Control Board at terminals L1 and L2. AC volts are converted to DC volts and are supplied to the Conveyor Motor at terminals A+ and A-. Adjustment of the Speed Control Potentiometer (5,000 ohm, 10 turn) will change resistance at terminals P1, P2, and P3 varying the DC voltage to the Conveyor Motor. The speed of the conveyor motor will increase or decrease as the DC voltage from the board increases or decreases respectively. As the motor turns, it drives both the reducer gear box and the Tach. Generator. The tach. generator is a DC voltage generator which supplies a voltage to the DC Motor Control Board and is used as a reference for maintaining a constant conveyor speed.
S/N 2011383 and above REFER TO PAGE B15	
TIME/TEMP DISPLAY	The secondary output of the Display Transformer, is supplied to terminals 1, 2, and 3 of the Time/Temp. Display. The secondary output of the Transformer is nominally 12.5 to 15 VAC with a center tap. The voltage from center tap to each leg is 1/2 the secondary voltage. The speed side of the Time/Temp. Display uses a slotted disc

S/N 2011383 and above
REFER TO PAGE B15

(cemented to tach. coupling) to break the infra-red light beam of the optical encoder(mounted on gear motor), producing electrical pulses that are transmitted to the display. The display converts these pulses into a read-out of minutes and seconds.

The temperature portion of the Time/Temp Display uses a Thermistor Probe to sense oven temperature. The thermistor outputs a resistance proportional to the oven temperature. This resistance is then converted by the display into a temperature reading.

AUTOMATIC COOL DOWN

When this oven is started, the time delay relay timing circuit is enabled, permitting the oven fans to run for approximately 20 minutes after the oven is shut off, to cool the oven. The Time Delay Relay will keep the coil of Relay closed, maintaining operation of the Main Fan Motor and the cooling fans

SEQUENCE OF OPERATIONS - 1151

MODEL 1151 ELECTRIC 200 VAC 60 HZ 3 PHASE

POWER SUPPLY	Electrical power to be supplied to the oven by a four conductor service.
CONTROL BOX AUTO COOL DOWN	When the temperature in the control box reaches $120^{\circ}\text{F} \pm 3^{\circ}\text{F}$ ($48.9^{\circ}\text{C} \pm 1.7^{\circ}\text{C}$), the Cooling Fan Thermostat closes, switching power to the Cooling Fans. The thermostat will open at $100^{\circ}\text{F} \pm 3^{\circ}\text{F}$ ($37.8^{\circ}\text{C} \pm 1.7^{\circ}\text{C}$) interrupting power to Cooling Fans.
MAIN FAN CIRCUIT	<p>Power is permanently supplied through a 1A fuse to the primary of the step-down transformer. The transformer steps the voltage down to 120 VAC for the control circuit. 120 VAC is supplied to terminal #1 of the 20 minute time delay relay, through the normally closed hi-limit thermostat, to a normally open contact of the oven start relay, the cooling fan thermostat and to the normally open main fan switch.</p> <p>Closing the fan switch energizes the oven start relay. These normally open contacts now close enabling the 20 minute timer delay. The 20 minute time delay relay supplies 120 VAC to the coil of the oven fan relay, these normally open contacts now close supplying 200 VAC to the main fan motor. The cooling fans, time/temp display, conveyor switch and heat switch are also energized.</p>
HEATER CIRCUIT	Closing the Heater Switch supplies 120 VAC through the normally open Air Pressure Switch (which was closed by Main Fan Air Pressure), through the 3 Amp Fuse, to the Temperature Control Board and to the Heater Lamp.
TEMPERATURE CONTROL	Closing the Heat Switch supplies 120 VAC to the Electronic Temperature Control. The 2.5K ohm Potentiometer is adjusted to achieve the desired temperature. The Thermocouple will provide varying millivolts to the Temperature Control. The temperature control board then supplies 120 VAC to the coil of the Contactor at intermittent intervals to maintain the desired temperature.
CONVEYOR DRIVE	Closing the Conveyor Switch supplies 120 VAC to the DC Motor Control Board at terminals L1 and L2. AC volts are converted to DC volts and are supplied to the Conveyor Motor at terminals A+ and A-. Adjustment of the Speed Control Potentiometer (5,000 ohm, 10 turn) will change resistance at terminals P1, P2, and P3 varying the DC voltage to the Conveyor Motor. The speed of the conveyor motor will increase or decrease as the DC voltage from the board increases or decreases respectively. As the motor turns, it drives both the reducer gear box and the Tach. Generator. The tach. generator is a DC voltage generator which supplies a voltage to the DC Motor Control Board and is used as a reference for maintaining a constant conveyor speed.
S/N 2011383 and above REFER TO PAGE B15	
TIME/TEMP DISPLAY	The secondary output of the Display Transformer, is supplied to terminals 1, 2, and 3 of the Time/Temp. Display. The secondary output of Transformer is nominally 12.5 to 15 VAC with a center tap. The voltage from center tap to each leg is 1/2 the secondary voltage.

2011383 and above
Refer to Page B15

The speed side of the Time/Temp. Display uses a slotted disc (cemented to tach. coupling) to break the infra-red light beam of the optical encoder(mounted on gear motor), producing electrical pulses that are transmitted to the display. The display converts these pulses into a read-out of minutes and seconds. The temperature portion of the Time/Temp Display uses a Thermistor Probe to sense oven temperature. The thermistor outputs a resistance proportional to the oven temperature. This resistance is then converted by the display into a temperature reading.

AUTOMATIC COOL DOWN

When this oven is started, the time delay relay timing circuit is enabled, permitting the oven fans to run for approximately 20 minutes after the oven is shut off, to cool the oven. The Time Delay Relay will keep the coil of Relay closed maintaining operation of the Main Fan Motor and cooling fans.

adjusted to desired temperature. The Thermocouple will provide varying millivolts to the Electronic Temperature Controller. The electronic temperature controller supplies 120 VAC to the Solenoid Valve at intermittent intervals to maintain desired temperature.

CONVEYOR DRIVE

S/N 2011821 and above
Page B15

Closing the Conveyor Switch supplies 120 VAC to the D.C. Motor Control Board at terminals L1 and L2. AC volts are converted to DC volts and are supplied to the Conveyor Motor at terminals A+ and A-. Adjustment of the Speed Control Potentiometer (5,000 ohm, 10 turn) will change resistance at Refer to terminals P1, P2, and P3 varying the DC voltage to the Conveyor Motor. The speed of the conveyor motor will increase or decrease as the DC voltage from the board increases or decreases respectively. As the motor turns, it drives both the reducer gear box and the Tach. Generator. The tach. generator is a DC voltage generator which supplies a voltage to the DC Motor Control Board and is used as a reference for maintaining a constant conveyor speed.

TIME/TEMP DISPLAY

S/N 2011821 and above
Refer to Page B15

The secondary output of the Display Transformer, is supplied to terminals 1, 2, and 3 of the Time/Temp. Display. The secondary output of Transformer is nominally 12.5 to 15 VAC with a center tap. The voltage from center tap to each leg is 1/2 the secondary voltage.

The speed side of the Time/Temp. Display uses a slotted disc (cemented to tach. coupling) to break the infra-red light beam of the optical encoder (mounted on gear motor), producing electrical pulses that are transmitted to the display. The display converts these pulses into a read-out of minutes and seconds.

The temperature portion of the Time/Temp Display uses a Thermistor Probe to sense oven temperature. The thermistor outputs a resistance proportional to the oven temperature. This resistance is then converted by the display into a temperature reading.

AUTOMATIC COOL DOWN

When this oven is started, the time delay relay timing circuit is enabled, permitting the oven fan to run for approximately 20 minutes after the oven is shut off, to cool the oven. The Time Delay Relay will keep the coil of Main Fan Relay closed, maintaining operation of the Main Fan Motor and cooling fans.

CONVEYOR DRIVE

Closing the Conveyor Switch supplies 120 VAC, through a 3 Amp Fuse, to the primary of the Conveyor Control Transformer. The secondary of this Transformer supplies 10 VAC and 29 VAC to the Conveyor Control. The Conveyor Control supplies voltage pulses to the Conveyor Motor. The Conveyor Control Potentiometer varies the frequency of these pulses. The motor speed will increase or decrease, as the frequency of the pulses increase or decrease respectively.

TIME/TEMP DISPLAY (STEPPER MOTOR DRIVE)

Closing the Main Fan Switch supplies 120 VAC to the primary of the Time/Temp Transformer. The secondary output of the Transformer, 12.5 to 15 VAC with a center tap, is supplied to terminals 1, 2, and 3 of the Time/Temp Display. The Display works on a balanced input, and center tap voltage to each leg must be 1/2 the total reading. The speed side of the Time/Temp Display is supplied by the Conveyor Control, with the frequency of the pulses to the Conveyor Motor. This frequency is converted by the Time/Temp Display into a read out of minutes and seconds.

NOTE:

The Conveyor Control uses a sensor and magnet, mounted on the Conveyor Motor that senses when the motor is not turning. If the motor is not turning, the Time/Temp Display will show “—:— “ in the window.

The temperature portion of the display uses a Thermistor Probe to sense oven temperature. The Thermistor outputs a resistance proportional to oven temperature. This resistance is then converted by the Display into a temperature reading.

OR:

The temperature portion of the display uses a “J” type thermocouple to measure oven temperature. The thermocouple generates D.C. millivolts proportional to oven temperature. This millivolt reading is then converted by the display into a temperature reading.

SCHEMATIC 1106

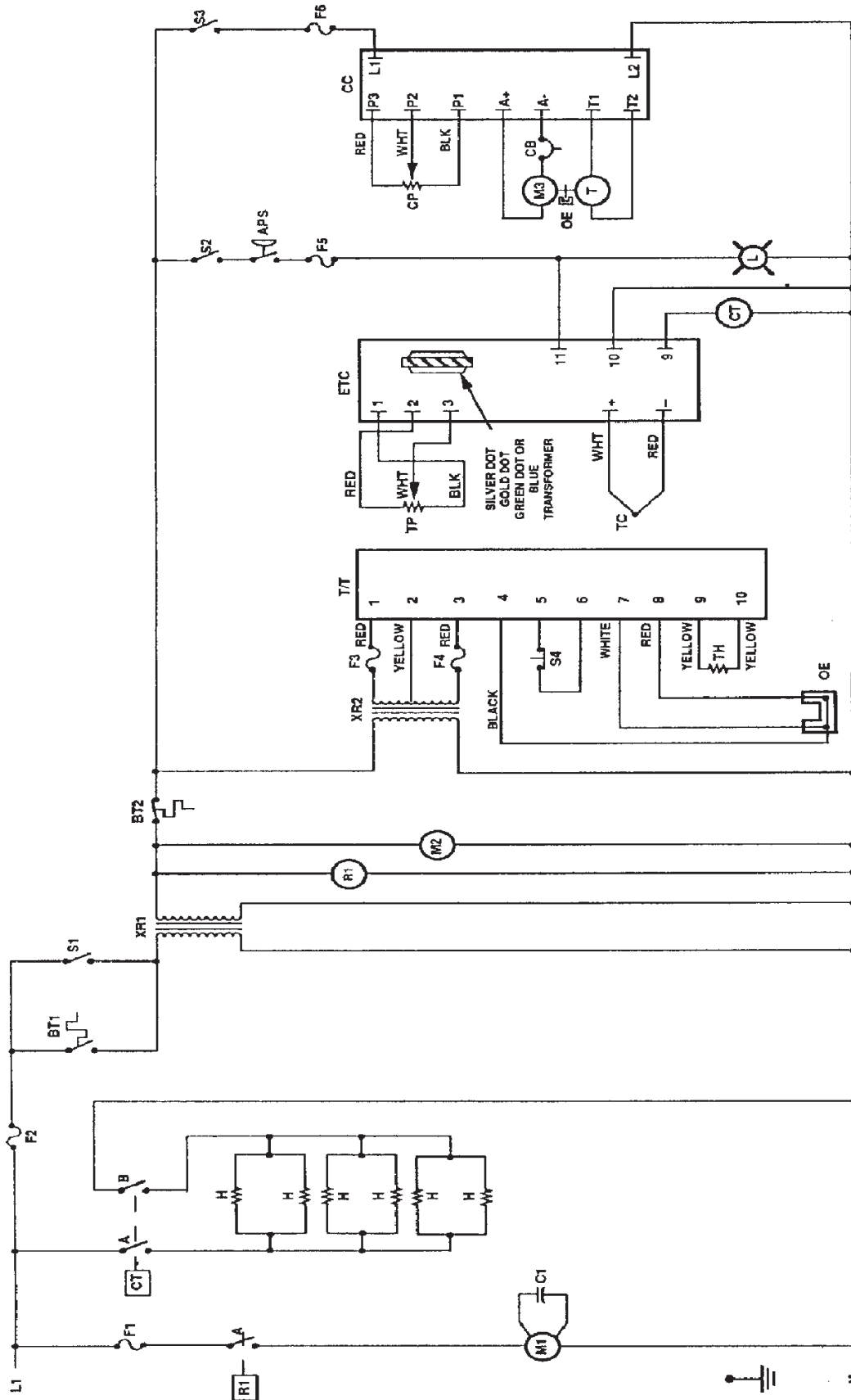

- BT1 - SWITCH, AIR PRESSURE
- BT2 - THERMOSTAT, OVER COOL DOWN
- CB - CONTACT, 1, OVER TRAY, 100V, 10A
- CC - CONTACT, 1, OVER TRAY, 100V, 10A
- CP - CIRCUIT BREAKER, 0.2 AMP
- CP - CONTROL BOARD, D.C. MOTOR
- CT - POTENTIOMETER, 0-4 K OHMS, 10 TURN
- H - MERCURY CONTACTOR, 3 POLE
- H - HEATING ELEMENTS, 240 V
- M1 - CONTROL BOARD, TEMPERATURE
- M2 - FUSE, 10 AMP, MAIN FAN MOTOR
- M3 - SWITCH, MAIN FAN, DYST
- M4 - FUSE, 4 AMP
- M5 - SWITCH, RELAYING, 30A1
- M6 - SWITCH, CONTACTOR, SPST
- M7 - SWITCH, DISPLAY, SET
- M8 - TACHOMETER
- M9 - LAMP, PILOT HEATER CIRCUIT
- M10 - MOTOR, MAIN FAN
- M11 - MOTOR, COOLING FAN
- M12 - POTENTIOMETER, 0-5.3K OHMS
- M13 - MOTOR, 10 AMP, MAIN FAN
- M14 - MOTOR, 10 AMP, MAIN FAN
- M15 - MOTOR, 10 AMP, MAIN FAN
- M16 - MOTOR, 10 AMP, MAIN FAN
- M17 - MOTOR, 10 AMP, MAIN FAN
- M18 - MOTOR, 10 AMP, MAIN FAN
- M19 - MOTOR, 10 AMP, MAIN FAN
- M20 - MOTOR, 10 AMP, MAIN FAN
- M21 - MOTOR, 10 AMP, MAIN FAN
- M22 - MOTOR, 10 AMP, MAIN FAN
- M23 - MOTOR, 10 AMP, MAIN FAN
- M24 - MOTOR, 10 AMP, MAIN FAN
- M25 - MOTOR, 10 AMP, MAIN FAN
- M26 - MOTOR, 10 AMP, MAIN FAN
- M27 - MOTOR, 10 AMP, MAIN FAN
- M28 - MOTOR, 10 AMP, MAIN FAN
- M29 - MOTOR, 10 AMP, MAIN FAN
- M30 - MOTOR, 10 AMP, MAIN FAN
- M31 - MOTOR, 10 AMP, MAIN FAN
- M32 - MOTOR, 10 AMP, MAIN FAN
- M33 - MOTOR, 10 AMP, MAIN FAN
- M34 - MOTOR, 10 AMP, MAIN FAN
- M35 - MOTOR, 10 AMP, MAIN FAN
- M36 - MOTOR, 10 AMP, MAIN FAN
- M37 - MOTOR, 10 AMP, MAIN FAN
- M38 - MOTOR, 10 AMP, MAIN FAN
- M39 - MOTOR, 10 AMP, MAIN FAN
- M40 - MOTOR, 10 AMP, MAIN FAN
- M41 - MOTOR, 10 AMP, MAIN FAN
- M42 - MOTOR, 10 AMP, MAIN FAN
- M43 - MOTOR, 10 AMP, MAIN FAN
- M44 - MOTOR, 10 AMP, MAIN FAN
- M45 - MOTOR, 10 AMP, MAIN FAN
- M46 - MOTOR, 10 AMP, MAIN FAN
- M47 - MOTOR, 10 AMP, MAIN FAN
- M48 - MOTOR, 10 AMP, MAIN FAN
- M49 - MOTOR, 10 AMP, MAIN FAN
- M50 - MOTOR, 10 AMP, MAIN FAN
- M51 - MOTOR, 10 AMP, MAIN FAN
- M52 - MOTOR, 10 AMP, MAIN FAN
- M53 - MOTOR, 10 AMP, MAIN FAN
- M54 - MOTOR, 10 AMP, MAIN FAN
- M55 - MOTOR, 10 AMP, MAIN FAN
- M56 - MOTOR, 10 AMP, MAIN FAN
- M57 - MOTOR, 10 AMP, MAIN FAN
- M58 - MOTOR, 10 AMP, MAIN FAN
- M59 - MOTOR, 10 AMP, MAIN FAN
- M60 - MOTOR, 10 AMP, MAIN FAN
- M61 - MOTOR, 10 AMP, MAIN FAN
- M62 - MOTOR, 10 AMP, MAIN FAN
- M63 - MOTOR, 10 AMP, MAIN FAN
- M64 - MOTOR, 10 AMP, MAIN FAN
- M65 - MOTOR, 10 AMP, MAIN FAN
- M66 - MOTOR, 10 AMP, MAIN FAN
- M67 - MOTOR, 10 AMP, MAIN FAN
- M68 - MOTOR, 10 AMP, MAIN FAN
- M69 - MOTOR, 10 AMP, MAIN FAN
- M70 - MOTOR, 10 AMP, MAIN FAN
- M71 - MOTOR, 10 AMP, MAIN FAN
- M72 - MOTOR, 10 AMP, MAIN FAN
- M73 - MOTOR, 10 AMP, MAIN FAN
- M74 - MOTOR, 10 AMP, MAIN FAN
- M75 - MOTOR, 10 AMP, MAIN FAN
- M76 - MOTOR, 10 AMP, MAIN FAN
- M77 - MOTOR, 10 AMP, MAIN FAN
- M78 - MOTOR, 10 AMP, MAIN FAN
- M79 - MOTOR, 10 AMP, MAIN FAN
- M80 - MOTOR, 10 AMP, MAIN FAN
- M81 - MOTOR, 10 AMP, MAIN FAN
- M82 - MOTOR, 10 AMP, MAIN FAN
- M83 - MOTOR, 10 AMP, MAIN FAN
- M84 - MOTOR, 10 AMP, MAIN FAN
- M85 - MOTOR, 10 AMP, MAIN FAN
- M86 - MOTOR, 10 AMP, MAIN FAN
- M87 - MOTOR, 10 AMP, MAIN FAN
- M88 - MOTOR, 10 AMP, MAIN FAN
- M89 - MOTOR, 10 AMP, MAIN FAN
- M90 - MOTOR, 10 AMP, MAIN FAN
- M91 - MOTOR, 10 AMP, MAIN FAN
- M92 - MOTOR, 10 AMP, MAIN FAN
- M93 - MOTOR, 10 AMP, MAIN FAN
- M94 - MOTOR, 10 AMP, MAIN FAN
- M95 - MOTOR, 10 AMP, MAIN FAN
- M96 - MOTOR, 10 AMP, MAIN FAN
- M97 - MOTOR, 10 AMP, MAIN FAN
- M98 - MOTOR, 10 AMP, MAIN FAN
- M99 - MOTOR, 10 AMP, MAIN FAN
- M100 - MOTOR, 10 AMP, MAIN FAN

MODEL 1106

SCHEMATIC 1134, 1135, 1150, S/N 2011383 AND BELOW

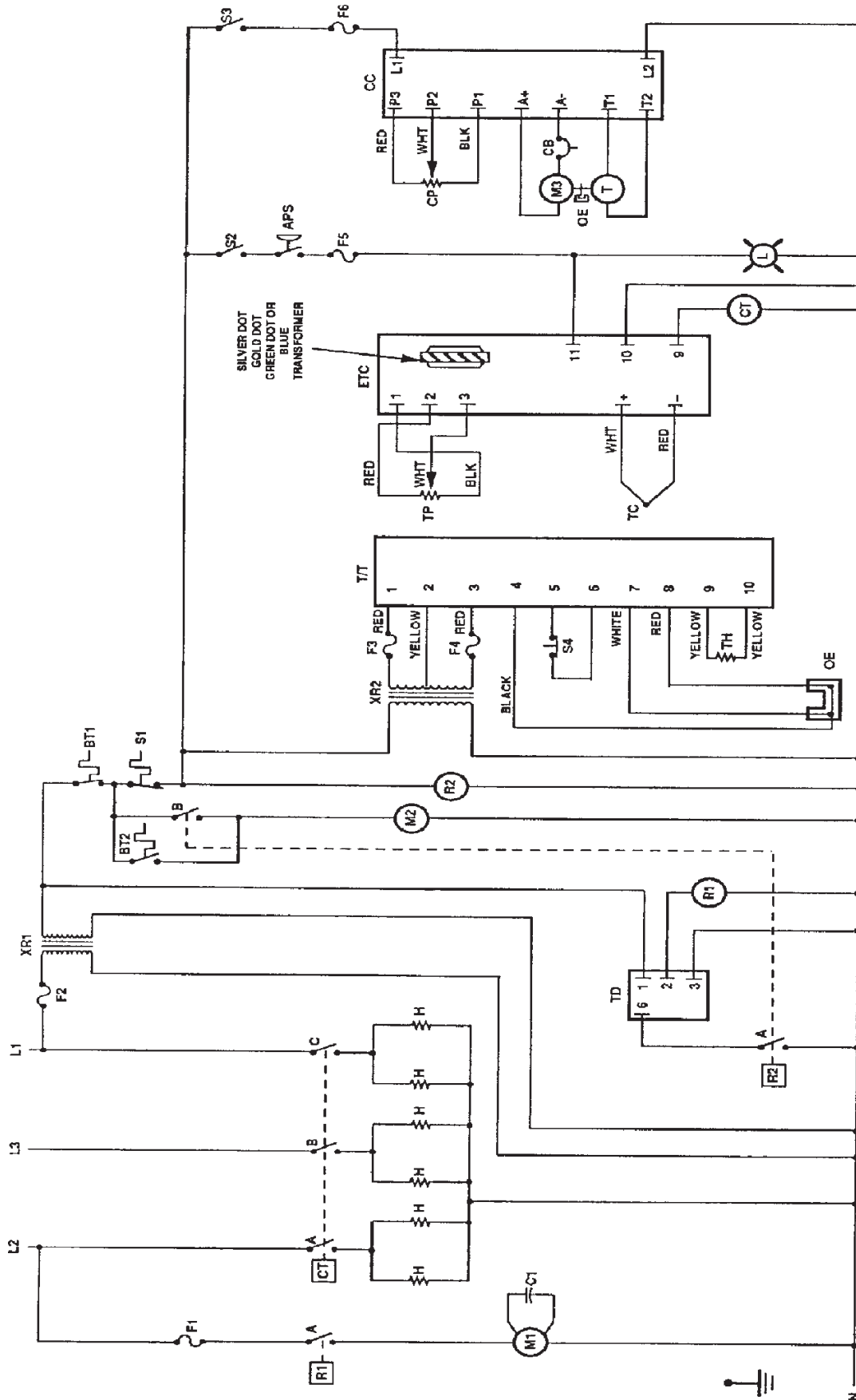

- APS - SWITCH, AIR PRESSURE
 BT1 - THERMOSTAT, OVEN CAVITY INCH LIMIT MODEL 1134, 1135
 BT2 - THERMOSTAT, COOLING FAN MODEL 1150
 C1 - CAPACITOR, 7.5 MFD 250V, MAIN FAN MOTOR
 CB - CONTROL BOARD, 0.2 AMP TOR
 CP - POTENTIOMETER, 0.1% OHMS, 10 TURN
 CT - HEATING ELEMENTS, 3 WATT, 55 AMP 240 V MODEL 1134, 1150
 H - HEATING ELEMENTS, 3 WATT, 55 AMP 240 V MODEL 1135
 * H - CONTROL BOARD, TEMPERATURE
 F1 - FUSE, 10 AMP, MAIN FAN MOTOR

- F2 - FUSE, 1 AMP, TRANSFORMER: BELOW S/N 200580 ABOVE S/N 200578
 F3 - FUSE, 4 AMP
 F4 - FUSE, 4 AMP
 F5 - FUSE, 3 AMP, HEATING CIRCUIT
 F6 - FUSE, 3 AMP, CONVEYOR CONTROL
 M1 - LAMP, 1/400 H, HEATING CIRCUIT
 M2 - MOTOR, MAIN FAN 1/2 HP
 M3 - MOTOR, COOLING FAN
 M4 - MOTOR, 1/2 HP
 OE - OPTICAL ENCODER 240 V MODEL 1134
 R1 - RELAY, MAIN FAN, DPST
 R2 - RELAY, COOLING FAN

- R3 - RELAY, MAIN FAN, DPST
 S1 - SWITCH, MAIN FAN, SPST
 S2 - SWITCH, HEATING, SPST
 S3 - SWITCH, CONVEYOR, SPST
 S4 - SWITCH, DISPLAY, SPST
 T - TACHOMETER
 TC - THERMOCOUPLE
 TD - TIME DELAY, 20 MINUTE
 TH - THERMISTOR PROBE
 TP - POTENTIOMETER, 0.2% OHMS
 XR1 - TRANSFORMER, CONTROL, 180 VAC: MODEL 1134
 XR2 - TRANSFORMER, 12.5 VAC MODEL 1134, 1150

* Units with serial number 200580 and below were originally equipped with a Farwell temperature control which is ordered from parts inventory. Replace with board 368729 plus a new potentiometer, part number 368520. See Section D for conversion and adjustment instructions.

MODELS 1134, 1135 and 1150

SCHEMATIC 1150 S/N 2011383 AND ABOVE

MODEL 1150

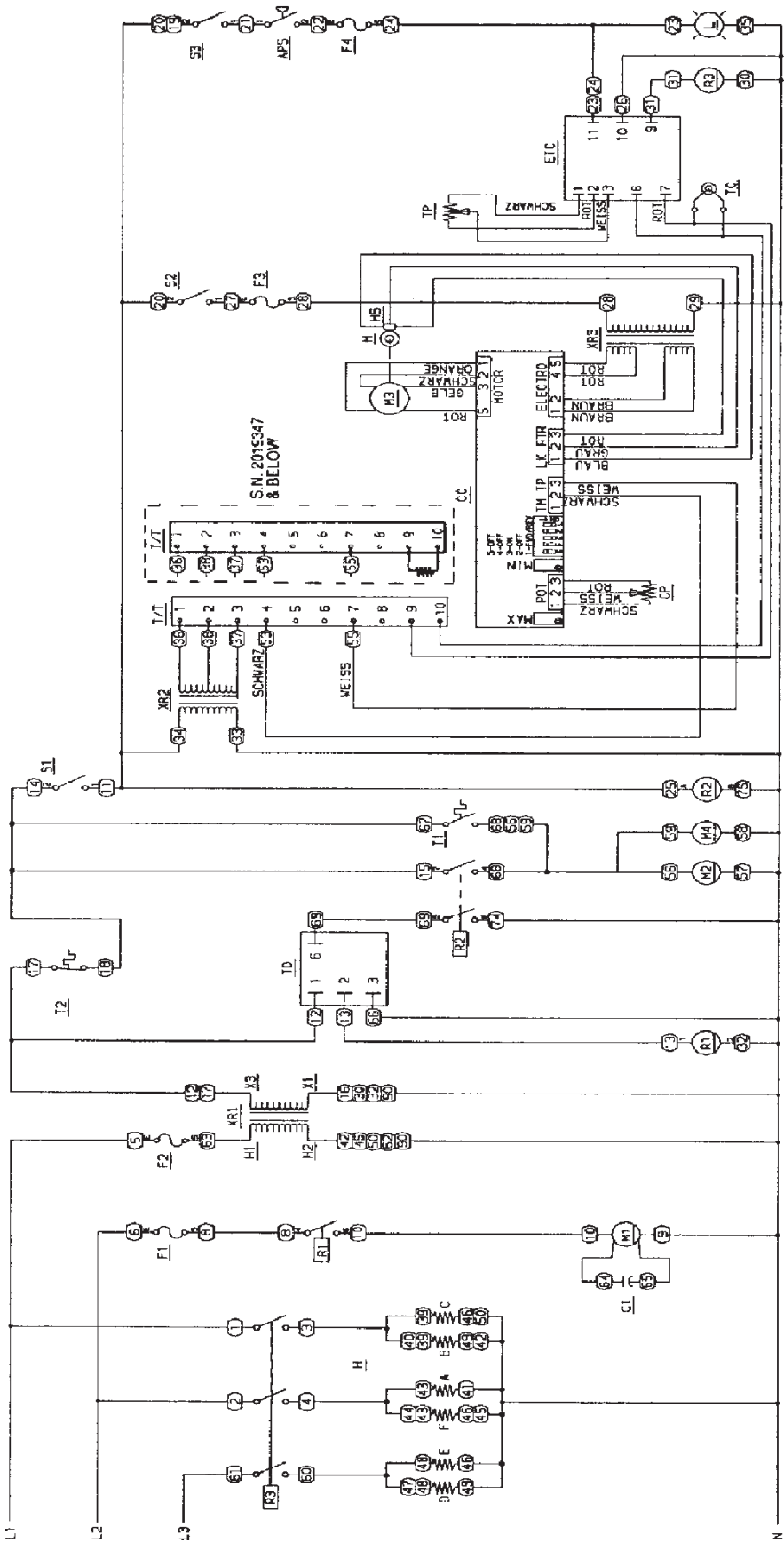

- R1 - RELAIS OEFEN LÜFTER
- R2 - RELAIS OEFEN ST. MIT-ABKÜHLUNG
- R3 - RELAIS HEIZKÖR
- R4 - RELAIS OEFEN VENTILATOR
- S1 - SCHALTER OEFEN VENTILATOR
- S2 - SCHALTER OEFEN HEIZUNG
- T1 - ELEKTRONISCHES THERMOSTAT KONTROLLBOX
- T2 - TEMPERATURGRENZER
- H - TEMPERATURFÜHLER
- TD - NACHLAUFRELAIS 20 MIN.
- TP - POTENTIOMETER TEMP.
- T71 - ZEIT-TEMP.-ANZEIGE
- XR1 - TRANSFORMATOR 220/115V
- XR2 - TRANSFORMATOR ZEIT-TEMP.
- XR3 - TRANSFORMATOR TRANSPORTBAND
- XX - KABELBESCHRIFTUNG

- APS - SCHALTER BRUCKSCHALTER LÜFTER GARRAUM
- C1 - KONDENSATOR 7,5 MFD
- CP - TRANSPORTBAND REGLER
- CP - POTENTIOMETER TRANSPORTBAND
- F1C - ELEKTRONIK THERMOSTAT
- F1 - STEUERUNG LÜFTER MOTOR 10A
- F2 - SICHERUNG TRANSFORMATOR, 1A
- F3 - SICHERUNG TRANSFORMATOR, 3A
- F4 - SICHERUNG THERMOSTAT, 3A
- H - HEIZKÖR, 1600W
- H5 - SUPRENSOR
- L - KONTROLLAMPE
- M - MAGNET
- M1 - OEFEN LÜFTER
- M2, M4 - LÜFTER KÜHLUNG (BELÜFTUNG)
- M3 - MOTOR TRANSPORTBAND

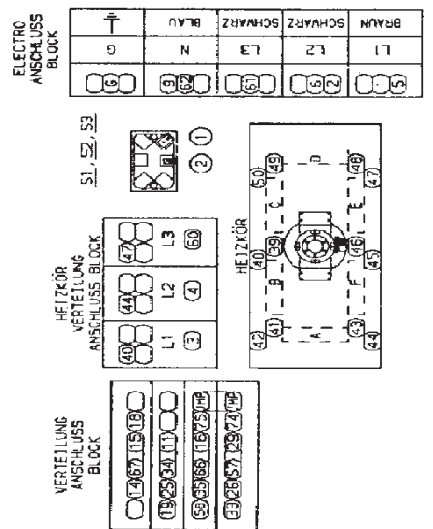

SCHEMATIC 1136, S/N 2011383 AND ABOVE

Model 1136

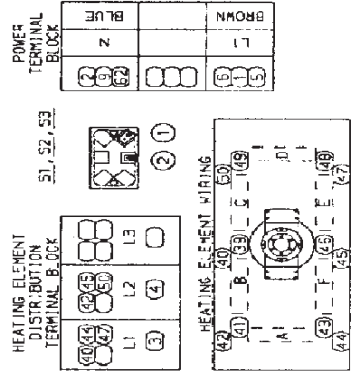
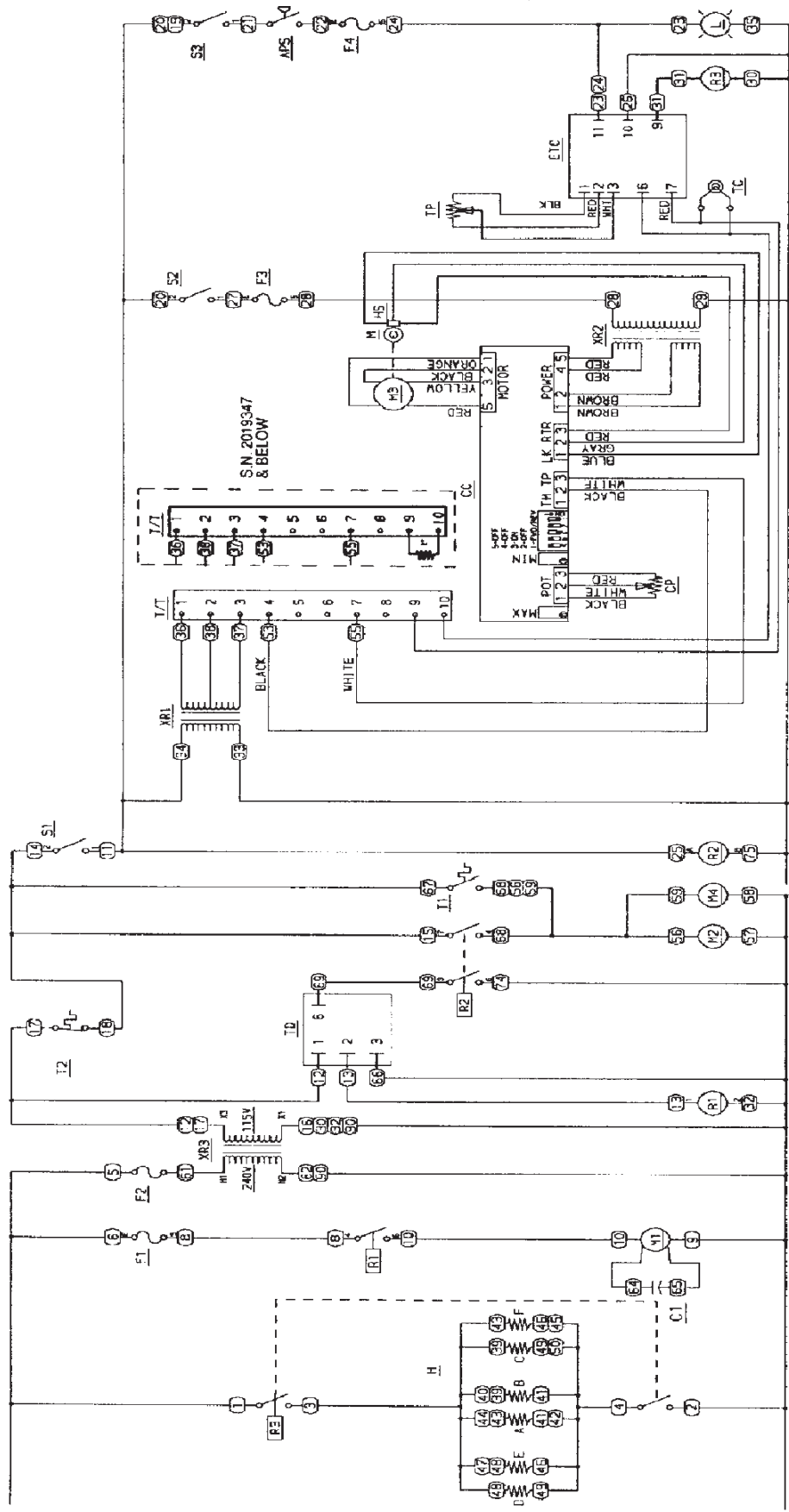

DISTRIBUTION TERMINAL BLOCK

1	2	3	4	5	6	7	8	9	10	11	12	13	14	15	16	17	18	19	20
---	---	---	---	---	---	---	---	---	----	----	----	----	----	----	----	----	----	----	----

- R2 - RELAY, OVEN START & COOL DOWN
- R3 - CONTACTORS, MERCURY
- S1 - SWITCH, OVEN FAN
- S2 - SWITCH, CONVEYOR
- S3 - SWITCH, OVEN HEAT
- T1 - THERMOSTAT, CONTROL BOX COOLING
- T2 - THERMOSTAT, HIGH LIGHT
- TD - THERMOCOUPLE, TYPE 1
- TP - TIME DELAY, 20 MINUTES
- Y/T - TEMPERATURE POT ASSEMBLY
- Y/T - TIME / TEMP
- XR1 - TRANSFORMER, CONVEYOR
- XR2 - TRANSFORMER, CONVEYOR
- XR3 - TRANSFORMER, POWER
- XX - WIRE NUMBERS

- APS - AIR PRESSURE SWITCH
- C1 - CAPACITOR, 7.5 MFD
- CC - CONVEYOR CONTROL
- CP - CONVEYOR POT ASSEMBLY
- ETC - ELECTRONIC TEMPERATURE CONTROL
- F1 - FUSE, FAN MOTOR, 10A
- F2 - FUSE, TRANSFORMER, 1A
- F3 - FUSE, CONVEYOR CONTROL, 3A
- F4 - FUSE, TEMPERATURE CONTROL, 3A
- H - HEATING ELEMENTS, 1600W (5 P.C.S.)
- H - HALL EFFECT SENSOR
- L - LAMP, HEATER INDICATOR
- M - MAGNET, OVEN FAN
- M1 - MOTOR, COOLING FAN
- M2 - MOTOR, CONVEYOR
- M3 - MOTOR, CONVEYOR
- R1 - RELAY, OVEN FAN MOTOR

SCHEMATIC 1151 S/N 2011383 AND ABOVE

Model 1151

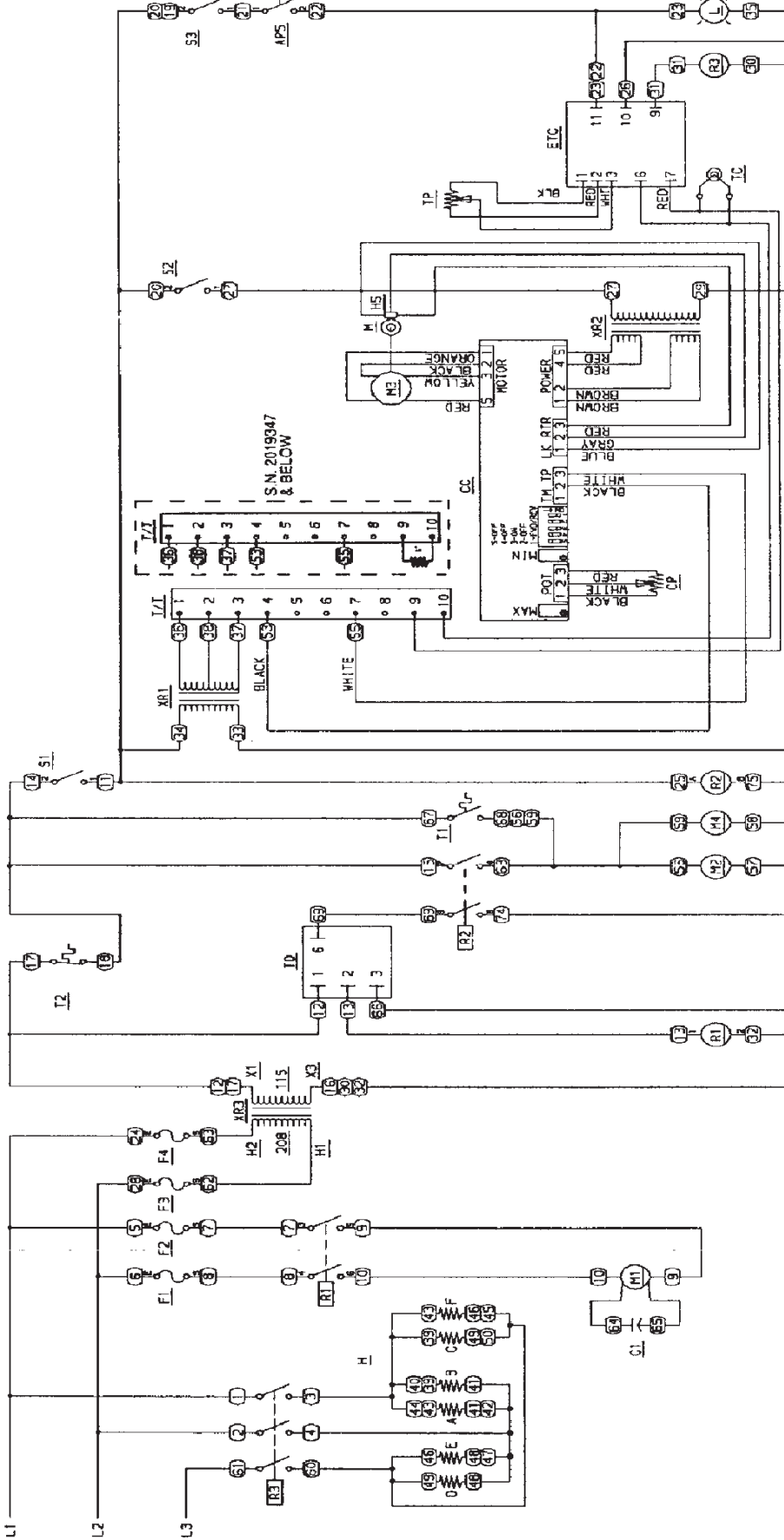

- R1 - RELAY, OVEN FAN MOTOR
- R2 - RELAY, OVEN START & COOL DOWN
- R3 - CONTACTORS, MERCURY
- S1 - SWITCH, OVEN FAN
- S2 - SWITCH, CONVEYOR
- S3 - SWITCH, OVEN HEAT
- T1 - THERMOSTAT, CONTROL BOX COOLING
- T2 - THERMOSTAT, HIGH LIMIT
- TC - THERMOCOUPLE, TYPE J
- TD - THERMOCOUPLE, 20 MINUTES
- T/T - TIME / TEMP
- XR1 - TRANSFORMER, CONVEYOR
- XR2 - TRANSFORMER, CONVEYOR
- XR3 - TRANSFORMER, POWER
- (XX) - WIRE NUMBERS

- APS - AIR PRESSURE SWITCH
- C1 - CAPACITOR, 7.5 MFD
- CC - CONVEYOR CONTROL
- CP - CONVEYOR POT ASSEMBLY
- ETC - ELECTRONIC TEMPERATURE CONTROL
- F1, F2 - FUSE, FAN MOTOR, 10A
- F3, F4 - FUSE, TRANSFORMER, 1A
- H - HEATING ELEMENTS, 1650W (5 PCS)
- H1 - HALL EFFECT SENSOR
- L - LAMP, HEATER INDICATOR
- M - MAGNET
- M1 - MOTOR, OVEN FAN
- M2, M4 - MOTOR, COOLING FAN
- M3 - MOTOR, CONVEYOR

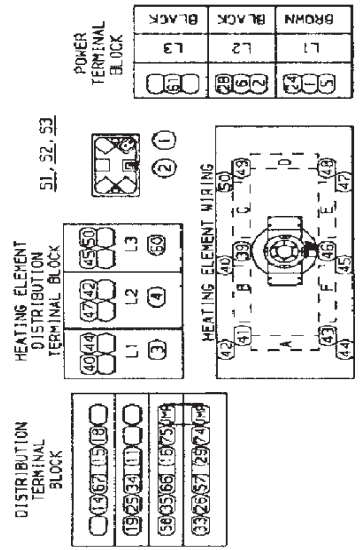

SCHEMATIC1152 THRU 1158 S/N 2011383 AND BELOW

MODELS 1152 through 1158

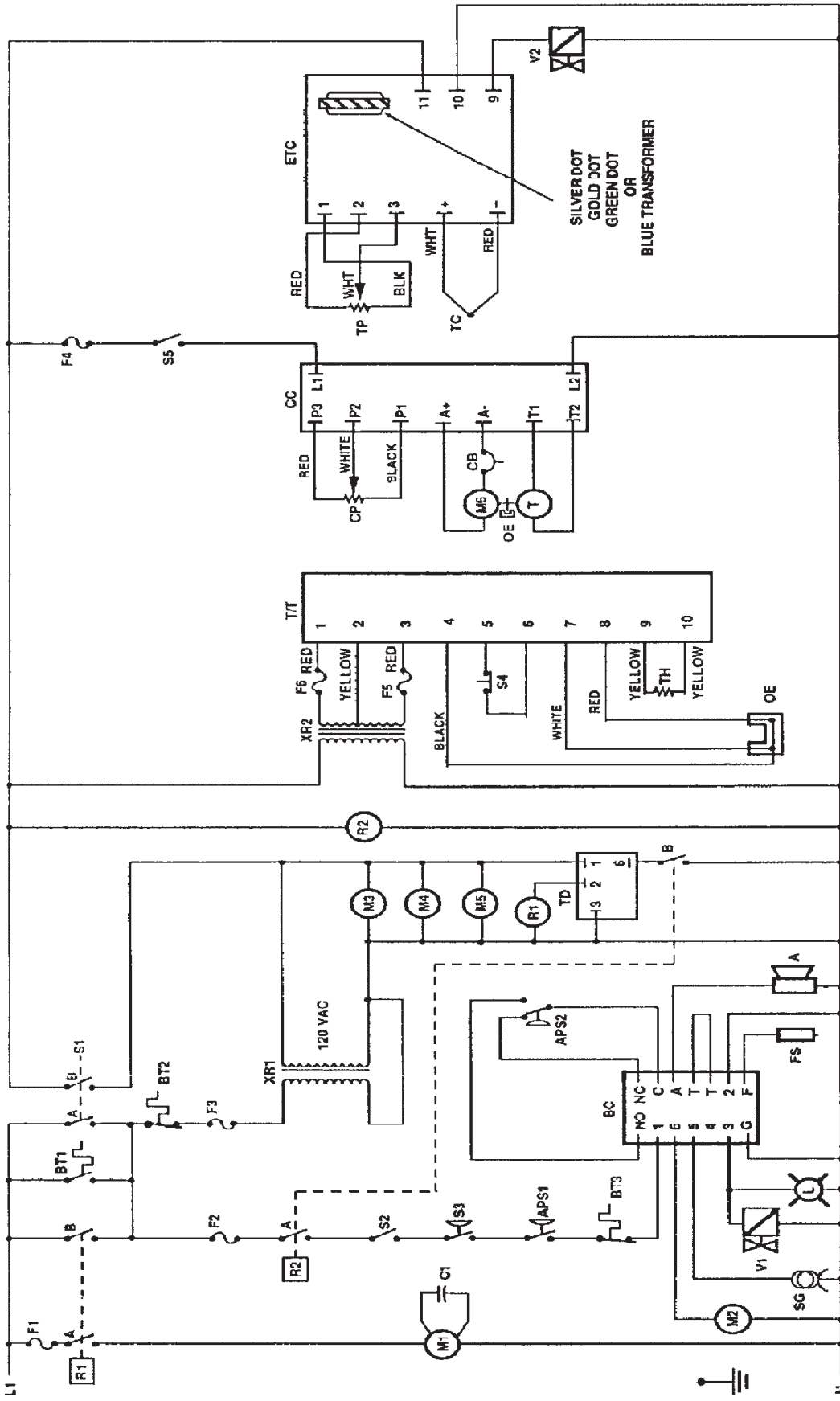

- A ALARM BUZZER
- APS1 AIR PRESSURE, OVER-CAVITY
- APS2 AIR PRESSURE, BURNER
- BC CONTROL BOARD, D.C. MOTOR
- BT1 THERMOSTAT, COOLING FAN
- BT2 THERMOSTAT, CONTROL BOX-HIGH LIMIT
- BT3 THERMOSTAT, OVEN CAVITY-HIGH LIMIT
- C1 CAPACITOR, 7.5 MFD, MAIN FAN MOTOR
- CC CIRCUIT BREAKER, 0.2 AMP
- CP POTENTIOMETER, 0.4 K OHMS, 10 TURN
- ETC CONTROL BOARD, TEMPERATURE
- F1 FUSE, 10 AMP, TIME DELAY, MAIN FAN
- F2 FUSE, 3 AMP, HEATER CONTROL
- F3 FUSE, 1 AMP, TIME DELAY, TRANSFORMER
- F4 FUSE, 3 AMP, CONVEYOR CONTROL
- F5 FUSE, 4 AMP, 12.5 VAC TRANSFORMER
- F6 FUSE, 4 AMP, 12.5 VAC TRANSFORMER
- FS FLAME SENSOR
- L LAMP, PILOT, BURNER
- M1 MOTOR, MAIN FAN
- M2 MOTOR, BURNER BLOWER
- M3 MOTOR, COOLING FAN, CONTROL BOX
- M4 MOTOR, COOLING FAN, CONTROL BOX
- M5 MOTOR, COOLING FAN, FRONT CONTROL BOX
- M6 D.C. GEAR MOTOR
- OE OPTICAL ENCODER
- R1 RELAY, OVEN FAN MOTOR
- R2 RELAY, HEATER CIRCUIT AND COOL. DOWN
- S1 SWITCH, MAIN FAN, DYST
- S2 SWITCH, BURNER, SPRT
- S3 SWITCH, GAS PRESSURE
- S4 SWITCH, DISPLAY, SET
- S5 SWITCH, CONVEYOR, SPRT
- SG SPARK GENERATOR
- T TACHOMETER
- TC THERMOCOUPLE, TYPE J
- TD TIME DELAY, 20 MINUTE
- TH THERMISTOR PROBE
- TP POTENTIOMETER, 0-2.5K OHMS
- T/T DISPLAY, TIME/TEMP.
- V1 SOLENOID, MAIN VALVE
- V2 SOLENOID, TEMP CONTROL
- XR1 TRANSFORMER, STEP DOWN 120 VAC
- XR2 TRANSFORMER, 12E VAC

SCHMATIC1152 THRU 1158 S/N 2011383 AND ABOVE

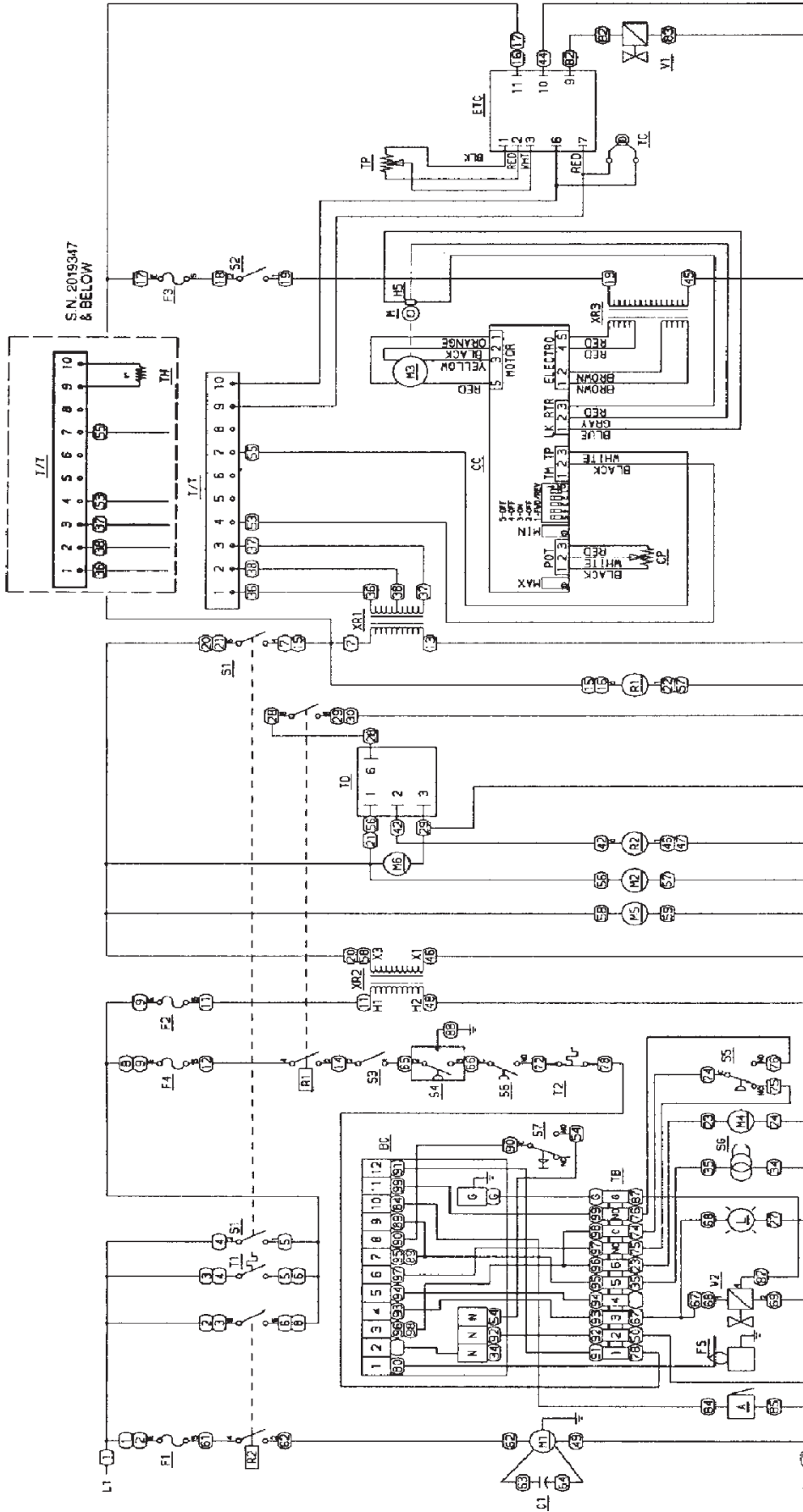

S.N. 2019347
& BELOW

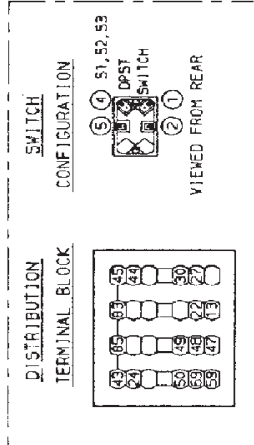

MODELS 1154 through 1158

- S1 - SWITCH, OVEN FAN
- S2 - SWITCH, CONVEYOR
- S3 - SWITCH, BURNER
- S4 - SWITCH, GAS INLET PRESSURE
- S5 - SWITCH, BURNER BLOWER AIR PRESSURE
- S6 - SWITCH, OVEN AIR PRESSURE
- S7 - LOCKOUT RESET SWITCH
- S8 - SPARK GENERATOR
- T1 - THERMOSTAT, CONTROL BOX COOLING
- T2 - THERMOSTAT, HIGH LIMIT
- T3 - THERMOCOUPLE, TYPE J
- TD - TIMER DELAY, 20 MINUTES
- TP - TEMPERATURE POT ASSEMBLY
- T-T - TIME/TEMP DISP. AY
- V1 - VA-VE, TEMPERATURE REGULATION
- V2 - VA-VE, MAIN & PILOT
- XR1 - TRANSFORMER, T/T, 12.0VAC CT
- XR2 - TRANSFORMER, POWER
- XR3 - TRANSFORMER, CONVEYOR
- (X) - WIRE NUMBERS

- A - ALARM
- BC - BURNER CONTROL
- C1 - CAPACITOR, 2.5 MFD
- CC - CONVEYOR CONTROL
- CP - CONVEYOR POT ASSEMBLY
- ETC - ELECTRONIC TEMPERATURE CONTROL
- F1 - FUSE, FAN MOTOR, 1.0A
- F2 - FUSE, TRANSFORMER, 1A
- F3 - FUSE, CONVEYOR, 3A
- F4 - FUSE, BURNER, 3A
- F5 - FLAME SENSOR
- H - HALL SENSOR
- L - LAMP, BURNER INDICATOR
- M - MAGNET
- M1 - MOTOR, OVEN FAN
- M2, M5, M6 - MOTOR, COOLING FAN
- M3 - MOTOR, CONVEYOR
- M4 - MOTOR, BURNER BLOWER
- R1 - RELAY, OVEN START & COOL DOWN
- R2 - RELAY, OVEN FAN MOTOR

SCHEMATIC 1152 AND 1153 S/N 2011821 AND ABOVE

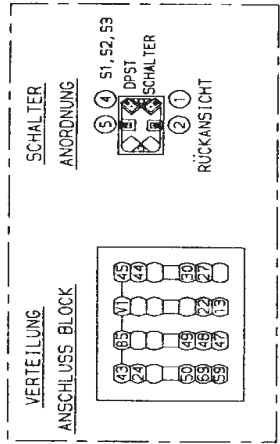
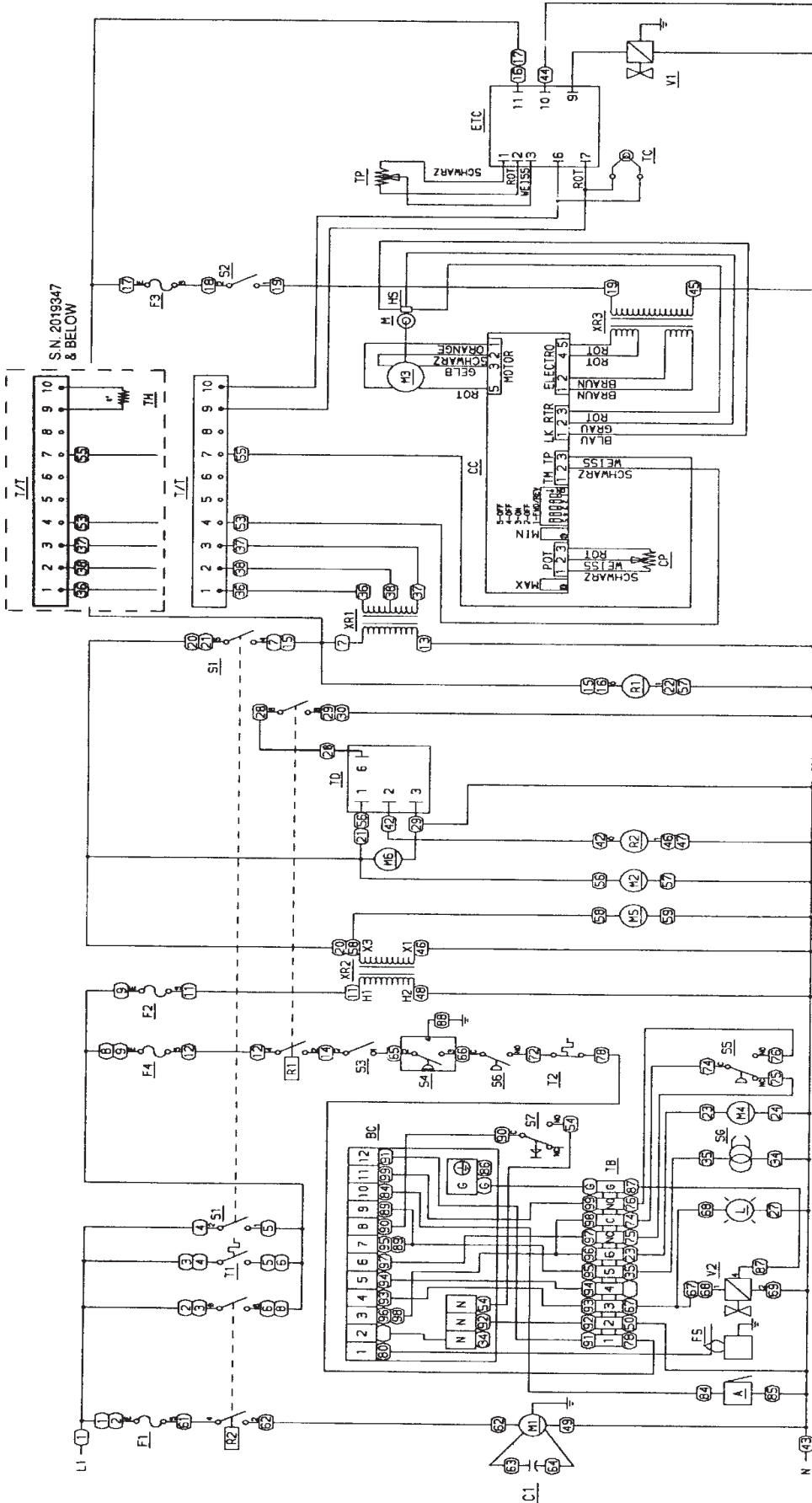

- 51 - SCHALTER OFFEN VENTILATOR
- 52 - SCHALTER BRENNER
- 53 - SCHALTER BASDRUCKSCHALTER
- 54 - SCHALTER BRENNERLÜFTER DRUCKSCHALTER
- 55 - SCHALTER BRENNERLÜFTER LÜFTER GARRAUM
- 56 - SCHALTER DRUCKSCHALTER LÜFTER GARRAUM
- 57 - STÖRUNGSENTRIEGELUNGSKNOPF
- 58 - ZUND TRAFU
- 59 - ELEKTRONISCHES THERMOSTAT KONTROLLBOX
- 60 - TEMPERATURBEZUGSPUNKT
- 61 - TEMPERATURBEZUGSPUNKT
- 62 - TEMPERATURBEZUGSPUNKT
- 63 - TEMPERATURBEZUGSPUNKT
- 64 - TEMPERATURBEZUGSPUNKT
- 65 - TEMPERATURBEZUGSPUNKT
- 66 - TEMPERATURBEZUGSPUNKT
- 67 - TEMPERATURBEZUGSPUNKT
- 68 - TEMPERATURBEZUGSPUNKT
- 69 - TEMPERATURBEZUGSPUNKT
- 70 - TEMPERATURBEZUGSPUNKT
- 71 - TEMPERATURBEZUGSPUNKT
- 72 - TEMPERATURBEZUGSPUNKT
- 73 - TEMPERATURBEZUGSPUNKT
- 74 - TEMPERATURBEZUGSPUNKT
- 75 - TEMPERATURBEZUGSPUNKT
- 76 - TEMPERATURBEZUGSPUNKT
- 77 - TEMPERATURBEZUGSPUNKT
- 78 - TEMPERATURBEZUGSPUNKT
- 79 - TEMPERATURBEZUGSPUNKT
- 80 - TEMPERATURBEZUGSPUNKT
- 81 - TEMPERATURBEZUGSPUNKT
- 82 - TEMPERATURBEZUGSPUNKT
- 83 - TEMPERATURBEZUGSPUNKT
- 84 - TEMPERATURBEZUGSPUNKT
- 85 - TEMPERATURBEZUGSPUNKT
- 86 - TEMPERATURBEZUGSPUNKT
- 87 - TEMPERATURBEZUGSPUNKT
- 88 - TEMPERATURBEZUGSPUNKT
- 89 - TEMPERATURBEZUGSPUNKT
- 90 - TEMPERATURBEZUGSPUNKT
- 91 - TEMPERATURBEZUGSPUNKT
- 92 - TEMPERATURBEZUGSPUNKT
- 93 - TEMPERATURBEZUGSPUNKT
- 94 - TEMPERATURBEZUGSPUNKT
- 95 - TEMPERATURBEZUGSPUNKT
- 96 - TEMPERATURBEZUGSPUNKT
- 97 - TEMPERATURBEZUGSPUNKT
- 98 - TEMPERATURBEZUGSPUNKT
- 99 - TEMPERATURBEZUGSPUNKT
- 100 - TEMPERATURBEZUGSPUNKT

- A - ALARM
- BC - BRENNER REGLER
- C1 - KONDENSATOR 7,5 MFD
- CC - TRANSPORTBAND REGLER
- CP - POTENTIOMETER TRANSPORTBAND
- ETC - ELEKTRONIK THERMOSTAT
- F1 - SICHERUNG LÜFTER MOTOR 10A
- F2 - SICHERUNG TRANSPORTBAND, 3A
- F3 - SICHERUNG BRENNER, 3A
- F4 - SICHERUNG TRANSPORTBAND, 3A
- F5 - SICHERUNG BRENNER (ÜBERBRÜCKUNG)
- H1 - SUMMENSENSOR (BRENNER)
- H2 - KONTROLLAMPE BRENNER
- M1 - OFFEN LÜFTER
- M2, M5, M6 - LÜFTER KÜHLUNG (BELÜFTUNG)
- M3 - MOTOR TRANSPORTBAND
- M4 - BRENNERLÜFTER
- R1 - RELAIS OFFEN START-ABKÜHLUNG
- R2 - RELAIS OFFEN LÜFTER

MODELS 1152 and 1153

SCHEMATIC 1154 THRU 1158 S/N 2011821 AND ABOVE

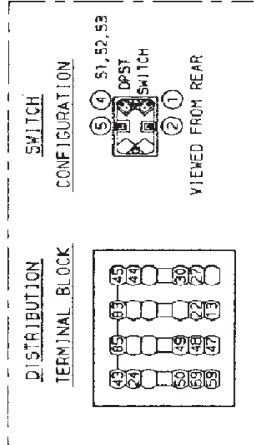
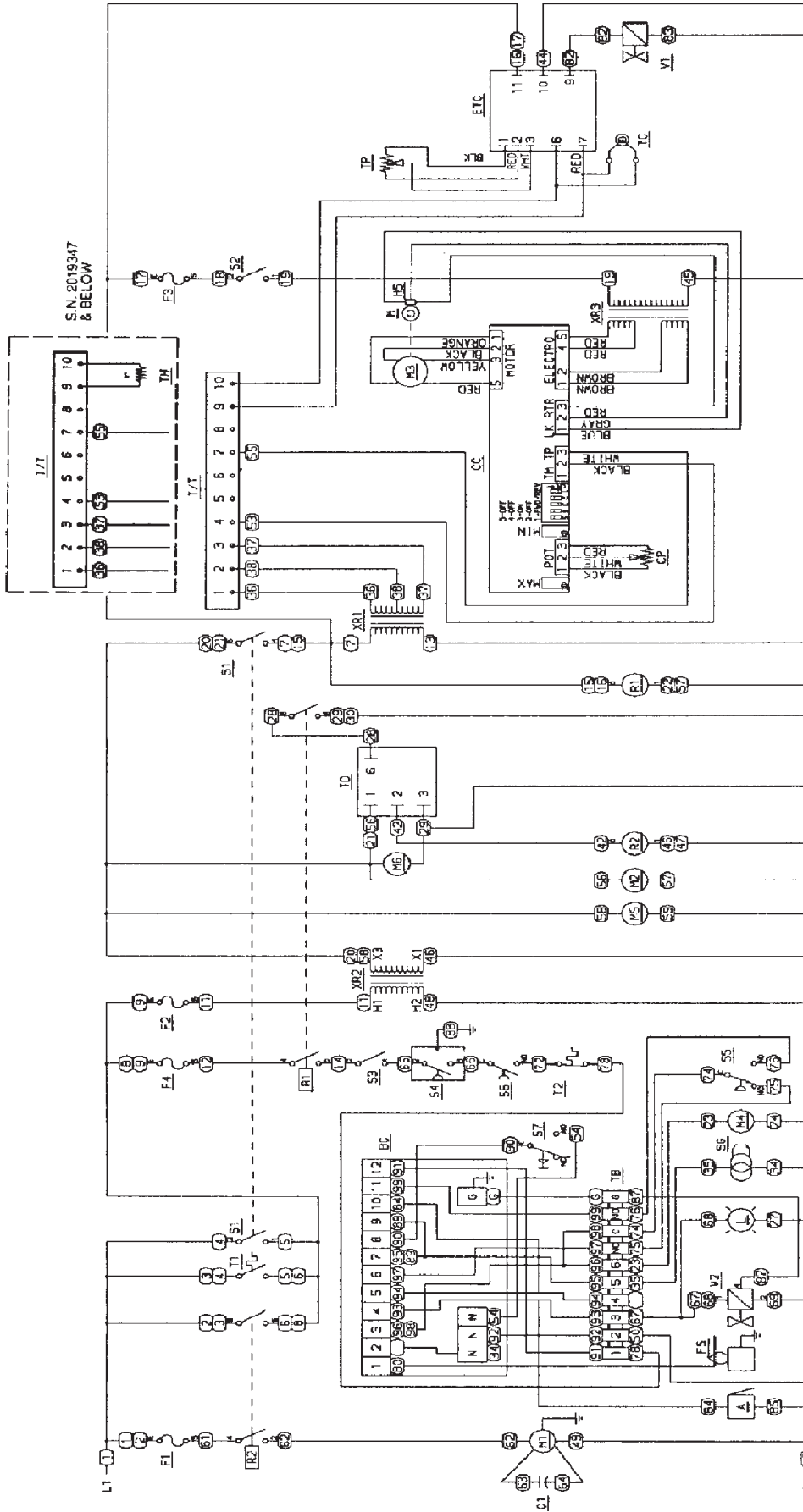

- S1 - SWITCH, OVEN FAN
- S2 - SWITCH, CONVEYOR
- S3 - SWITCH, BURNER
- S4 - SWITCH, GAS INLET PRESSURE
- S5 - SWITCH, BURNER BLOWER AIR PRESSURE
- S6 - SWITCH, OVEN AIR PRESSURE
- S7 - LOCKOUT RESET SWITCH
- S8 - SPARK GENERATOR
- T1 - THERMOSTAT, CONTROL BOX COOLING
- T2 - THERMOSTAT, HIGH LIMIT
- TC - THERMOCOUPLE, TYPE J
- TD - TIMER DELAY, 20 MINUTES
- TP - TEMPERATURE POT ASSEMBLY
- T-T - TIME/TEMP DISPLAY
- V1 - VALVE, TEMPERATURE REGULATION
- V2 - VALVE, MAIN & PILOT
- XR1 - TRANSFORMER, T/T, 12.0VAC CT
- XR2 - TRANSFORMER, POWER
- XR3 - TRANSFORMER, CONVEYOR
- (X) - WIRE NUMBERS

- A - ALARM
- BC - BURNER CONTROL
- C1 - CAPACITOR, 2.5 MFD
- CC - CONVEYOR CONTROL
- CP - CONVEYOR POT ASSEMBLY
- ETC - ELECTRONIC TEMPERATURE CONTROL
- F1 - FUSE, FAN MOTOR, 1.0A
- F2 - FUSE, TRANSFORMER, 1A
- F3 - FUSE, CONVEYOR, 3A
- F4 - FUSE, BURNER, 3A
- F5 - FLAME SENSOR
- H - HALL SENSOR
- L - LAMP, BURNER INDICATOR
- M - MAGNET
- M1 - MOTOR, OVEN FAN
- M2, M5, M6 - MOTOR, COOLING FAN
- M3 - MOTOR, CONVEYOR
- M4 - MOTOR, BURNER BLOWER
- R1 - RELAY, OVEN START & COOL DOWN
- R2 - RELAY, OVEN FAN MOTOR

MODELS 1154 through 1158

TROUBLE SHOOTING GUIDE GAS OVENS

MODELS 1152 - 1153 - 1154 - 1155 - 1156 - 1157 - 1158

REFER TO PROPER SCHEMATIC FOR IDENTIFIED COMPONENTS

SYMPTOM	POSSIBLE CAUSE	EVALUATION
Oven fan will not run	Incoming Power Supply	Check circuit breakers, reset if required, call power company if needed.
	Main Fan Switch	Check continuity between switch terminals.
	Control Box High Limit Thermostat NOTE: Discontinued at S/N 2011821	Terminals are normally closed, and open at 170°F ± 5F (76.6°C ± 2.8°C). Check for over heating and reset thermostat. Test for proper operation. If it will not reset and hold, replace thermostat.
	Fuse, 1 Amp Fuseholder Transformer, Step Down	Check, replace if necessary. Check, replace if necessary. 120 VAC ± 10% should be present at secondary of transformer. If proper voltage is not present, check transformer primary for proper input. Replace as needed.
	Oven Start Relay	Check for 120 VAC to relay coil. If voltage is not present, trace wiring back to power source. If voltage is present, check to insure contact is closing.
	20 Minute Time Delay	Check for 120 VAC at terminal #1 to neutral on 20 minute Time Delay Relay. If no voltage is present, trace wiring back to power source. If voltage is present at terminal #1, check for 120 VAC at terminal #2 to neutral. If no voltage is present, and cool down relay contact is closed, replace Time Delay Relay.
	Main Fan Relay	Check for 120 VAC to coil of the Relay if no voltage is present, trace wiring back to 20 minute Time Delay Relay. If voltage is present, check to insure contacts are closing.
	Fuse, 10 Amp Fuseholder Motor Capacitor Main Fan Motor	Check, replace if necessary. Check, replace if necessary. Check for opens, shorts, or grounds. Check for supply voltage to main fan motor. If voltage is not present, trace wiring back to main fan relay. Check for opens, shorts, or grounds. WITH POWER OFF: turn fan blade to check for locked rotor.

No main fan cool down	20 Minute Time Delay Relay	Check for 120 VAC at pin#2 and #3 while main fan is running. Turn off main fan switch and 120 VAC should continue to be present for 20 minutes. Check if relay is operating and terminals are remaining closed for main fan cool down of 20 minutes. NOTE: The time delay relay will keep the coil of the main fan relay closed, maintaining main fan operation for cool down for approximately 20 minutes. Contacts of the relay should open when main fan is switched off. 120 VAC at terminal 2 should discontinue approximately 20 minutes after main fan is switched off. If cool down relay is open and voltage continues at terminal 2, replace time delay.
	Main Fan Relay	
Main fan runs after 20 minute cool down	Cool Down Relay	When voltage at terminal 2 of time delay ceases, main fan relay must open. Check main circuit breakers, reset if required, call power company if needed. Check continuity between switch terminals. Terminals are normally closed, and open at 170°F ± 5°F (76.6°C ± 2.8°C). Check for over heating and reset thermostat. Test for proper operation. If it will not reset and hold, replace. Check, replace if necessary. Check, replace if necessary. 120 VAC should be present on secondary. Replace as needed. 120 VAC should now be at these fan motors. If voltage is present, check motors for shorts or opens. WITH POWER OFF: Check for locked rotor. Check circuit breakers, reset if required, call power company if needed Cooling Fan Thermostat Thermostat is normally open and closes at 120°F ± 3 (48.9°C ± 1.7°), and opens at 100°F ± 3°F (37.8°C ± 1.7°C). Terminals are normally closed, but open at 170°C ± 5°F (76.6°C ± 2.8°C). Check for over heating and reset thermostat. Test for proper operation. If it will not reset and hold, then replace. Check, replace if necessary. Check, replace if necessary. 120 VAC ± 10% should be present at secondary of transformer. If proper voltage is not present, check transformer primary for proper input. Replace as needed.
	Time Delay	
	Main Fan Relay	
No control box cooling	Incoming Power	Check main circuit breakers, reset if required, call power company if needed. Check continuity between switch terminals. Terminals are normally closed, and open at 170°F ± 5°F (76.6°C ± 2.8°C). Check for over heating and reset thermostat. Test for proper operation. If it will not reset and hold, replace. Check, replace if necessary. Check, replace if necessary. 120 VAC should be present on secondary. Replace as needed. 120 VAC should now be at these fan motors. If voltage is present, check motors for shorts or opens. WITH POWER OFF: Check for locked rotor. Check circuit breakers, reset if required, call power company if needed Cooling Fan Thermostat Thermostat is normally open and closes at 120°F ± 3 (48.9°C ± 1.7°), and opens at 100°F ± 3°F (37.8°C ± 1.7°C). Terminals are normally closed, but open at 170°C ± 5°F (76.6°C ± 2.8°C). Check for over heating and reset thermostat. Test for proper operation. If it will not reset and hold, then replace. Check, replace if necessary. Check, replace if necessary. 120 VAC ± 10% should be present at secondary of transformer. If proper voltage is not present, check transformer primary for proper input. Replace as needed.
	Main Fan Switch	
	Control Box High Limit Thermostat Note: Discontinued at S/N 2011821	
	Fuse, 1 Amp Fuseholder Step Down Transformer	
	Cooling Fans	
No automatic control box cooling	Incoming Power Supply	Check main circuit breakers, reset if required, call power company if needed Cooling Fan Thermostat Thermostat is normally open and closes at 120°F ± 3 (48.9°C ± 1.7°), and opens at 100°F ± 3°F (37.8°C ± 1.7°C). Terminals are normally closed, but open at 170°C ± 5°F (76.6°C ± 2.8°C). Check for over heating and reset thermostat. Test for proper operation. If it will not reset and hold, then replace. Check, replace if necessary. Check, replace if necessary. 120 VAC ± 10% should be present at secondary of transformer. If proper voltage is not present, check transformer primary for proper input. Replace as needed.
	Control Box Hi Limit Discontinued at S/N 2011821	
	Fuse, 1 Amp Fuseholder Step Down Transformer	

	Cooling Fans	120 VAC should now be at these fan motors. If voltage is present, check motors for shorts or opens.
Cooling fans continue 20 minute	Cooling Fan Thermostat	WITH POWER OFF: Check for locked rotor. Thermostat is normally open and may to run after have closed if control box temperature cool down is 120°F or above.
Oven will not heat	Gas Supply	Check for adequate gas supply and manual gas shut off valve is open. Also, check flexible gas line connection.
	Main Fan	If not operating, refer to "Oven Fan Will Not Run" on Page C6.
	Fuse 3 Amp	Check, replace if necessary.
	Fuseholder	Check, replace if necessary.
	Relay Oven Start	Supply voltage should be present across these terminals.
	Burner Switch	Check for supply voltage on both sides of switch. If switch is closed and voltage present on one side only, replace switch.
	Gas Pressure Switch	This switch is located inside the gas valve and should close when gas pressure is present. WITH POWER OFF: remove 3 prong plug (on gas valve) and measure continuity between terminals 2 and 3. NOTE: Remove insulation pad below plug to read numbers. If no continuity, check the following: Proper gas pressure supply to gas valve as marked on the oven specification plate. Check for proper adjustment of gas pressure switch 8.8 on dial for natural gas, 23 for LP, and 4.5 for Town Gas. Check gas filter in gas valve for blockage or damage. (See Adjustment section for location) If above checks are okay, but pressure switch is still not closed, replace gas valve.
	Air Pressure Switch	Check air switch terminals for supply voltage at NO 2 and COM. If voltage is present on one side only, check for air tube blockage or misalignment. If these are okay, adjust switch or replace necessary.
	(Oven Cavity) High Limit	Terminals are normally closed, Thermostat opens at 660°F (350°C). If open, push in reset button and retest. If thermostat will not hold for maximum oven temperature, and oven is not exceeding temperature dial setting, check for proper location of capillary bulb in its spring holder. If above check okay, replace hi-limit thermostat.
	Ignition Control	Check for proper supply voltage to ignition control.

Burner Blower Motor	<p>Check for proper line voltage to the Burner Blower Motor. This can be checked at motor connecting plug terminal 2 and 5. If voltage is present proceed with next step, if not, wait 30 seconds, push reset button, and try to restart. If this fails, check wires from Thermostat and Burner Blower Motor to the Ignition Control. If all above fails and wires are okay, replace ignition control.</p> <p>Check for supply voltage to motor. WITH POWER OFF: turn blower wheel to check for locked rotor.</p>
Air Pressure Switch (Burner Blower)	<p>If proper supply voltage is present at motor connecting plug, terminal 2 and 5 and motor does not run, replace motor</p> <p>Check for proper supply voltage switching from "N.C." to "N.O." as air pressure switch closes.</p> <p>If above fails, connect a temporary jumper wire (FOR TESTING ONLY) from terminal "C" to terminal "N.O." on ignition control (bypasses air switch). NOTE: For Honeywell control only.</p>
Spark Generator	<p>Check for air switch adjustment, air tube blockage, or misalignment, and if these fail, replace air pressure switch</p> <p>A pre-purge-time of 30 to 60 seconds occurs after blower motor starts, check for supply voltage at spark generator.</p> <p>If voltage is not present, check reset button for the Ignition Control.</p> <p>If voltage is still not present, replace ignition control.</p> <p>If voltage is present, visually check for spark at ignitor head located in burner.</p>
Ignitor/Sensor Assembly	<p>Check this assembly for visible damage. If there is no damage, replace the Spark Generator. If there is damage, replace the Ignitor/Sensor Assembly. Also check for frayed or damaged wires in the burner tube.</p>
Gas Valve	<p>Gas valve should open when proper supply voltage is present.</p> <p>If no voltage is present, check the reset button on the ignition control, and all connections for tightness. If there is still no voltage present at gas valve, replace ignition control. If there is voltage present, check for gas pressure at the gas pressure tap located in the gas piping just prior to the burner. If there is no gas pressure, replace gas valve</p>

Flame will not stay on	Flame Sensor	<p>To check for flame sensor operation, connect a digital multimeter (capable of measuring D.C. micro amps) between the flame sensor wire and terminal "F" on the Honeywell Ignition Control or terminal 1 on Landis & Gyr Ignition Control. Sensor current from Honeywell is 2 to 4 D.C. micro amps. Sensor current from Landis & Gyr is 3 micro amps minimum.</p> <p>If these readings are not achieved replace ignitor/sensor assembly. Also check for any type of damage to flame sensor wire and connections.</p> <p>NOTE: The D.C. micro amp test must be conducted with the oven in low flame (bypass) operation.</p>
	Power Supply	<p>Turn the temperature control to the lowest setting. If there is sufficient micro-amp current, but the flame will not stay lit, check for proper polarity of the power supply</p>
	Ignition Control	<p>If there is sufficient flame sensor current, but the burner will not remain ignited, check the reset button on ignition control. If all above are okay, replace ignition control.</p>
Pilot lamp is on, but no main flame	Temperature Control	<p>Check for 120 VAC across terminals 10 and 11 on temperature control board. If no voltage is present, check wiring back to the Main Fan Switch. Turn the temperature adjustment knob to the maximum temperature position and check for 120 VAC at the load terminal (number 9), and neutral (number 10).</p>
	Thermocouple Probe	<p>If 120 VAC is present and unit is not heating, refer to "Solenoid Valve" for next check. If 120 VAC is not present, proceed with next step.</p>
	Temperature Control Potentiometer	<p>With power on and thermocouple leads attached to board, measure the millivolt output of these leads. Refer to the thermocouple chart in Section D for proper readings.</p> <p>WITH POWER OFF: Remove the potentiometer leads from the temperature control board and measure ohms from black to whiteleads. The reading should be from approximately 0 to 2.5K ohms as the dial of the potentiometer is turned through its full rotation. From black to red leads, the reading should be approx.2.5K ohms and remain steady throughout the full rotation of the potentiometer.</p> <p>If the thermocouple probe and the control potentiometer check good,</p>

	Temperature Control Valve	then the problem is usually with the temperature control board. If 120 VAC is present on the temperature control board at load terminal to neutral, check for voltage at Temperature Control valve. If voltage is present, listen for valve to open and close. Also check for opens or shorts in the coil. Replace if required.
Intermittent heating	Thermal Overload Of Main Fan and Burner Blower Motors	Both the main fan motor and the burner blower motor are equipped with internal thermal protection and will cease to operate if overheating occurs. As the motors overheat and then cool, this will cause the units to cycle on and off intermittently. This may be caused by improper ventilation or preventative maintenance. Also, most of the problems listed under "Oven Will Not Heat" can cause intermittent failure. Check and replace if defective. Check and replace if defective. Check for continuity between switch terminals.
Conveyor will not run	3 Amp Fuse Fuseholder Fan Switch	Check for continuity between switch terminals.
S/N 2011821 & Above Refer to Page 45	Conveyor Switch	Check for continuity between switch terminals.
	Speed Adjustment Potentiometer.	This is a 0 to 5 K ohm, 10 turn WITH POWER OFF: Remove the red, black and white pot. leads from the motor control board at terminals P1, P2 and P3. With a digital multimeter, check the ohm reading across the red lead to the black lead. This reading should be 5 K ohms \pm 5% as the pot is rotated from low to high. Place the meter leads on the red lead and on the white lead. Rotating the pot. slowly, from low to high, the meter reading should show an even transition from 0 to 5 K ohms \pm 5%. There should be no dead or open spots through out the 10 turns of the pot. Check all three leads to ground. There should be no continuity to ground. If any of the above checks fail, replace the pot.
	DC Motor Control Board	Check for 120 VAC input to the control board at terminals L1 and L2. If not present, check the conveyor switch and wiring back to the 3 amp fuse and then back to the power source if necessary. If 120 VAC is present at L1 and L2, check the VDC output at terminals A+ and A-. If a DC voltage is not present, check the 4 amp and the 1 amp fuses on the

		control board. If 120 VAC is present at terminals L1 and L2, but DC Voltage is not present at A+ and A-, providing the fuses are good, replace the board. If DC voltage is present at A+ and A-, but motor does not run, check gear motor as follows.
	Conveyor Gear Motor	If DC voltage is present at A+ and A- and the motor does not run, first check the mini breaker and then the conveyor. As described below under conveyor. Check the leads to the motor for evidence of any shorts or opens, and each lead to ground. Check motor brushes. Replace as needed. If the motor fails the above tests, replace motor. Remove the dust cover from the top of the motor and rotate motor shaft to determine if there is a locked rotor or a locked gear box (use care so encoder disc is not damaged).
	Conveyor	Check for any mechanical mis- alignment or improper adjustment. Also check for worn bearings. The Installation and Operations Manual shows proper conveyor belt position. A conveyor belt that is too tight will contribute to excessive load, bearing wear, and wearing of slider bed rods.
Conveyor speed varying or intermittent	Power Supply	Check power supply at the DC control board for the 120 VAC \pm 10% at board terminals L1 and L2. If voltage is not present, trace wiring back to the power input, check the main circuit breakers and call the power company if necessary.
S/N2011821 & above Refer to page 45	Tach. generator and DC Motor Control Board	With the power to the DC motor control board turned off, remove the leads from terminals T1 and T2. Place the test leads of a digital test meter on the tach. leads, turn power on, and the meter reading should be approximately 20 to 25 VDC. This reading is normally steady within \pm 0.2 to 0.3 VDC. If this reading is not within required VDC, place the test meter probes on terminals A+ and A-. The meter reading should be approximately 150 to 160 VDC and steady within approximately 2 to 3 VDC. If the tach. voltage is unsteady, and the board output is steady, check the coupling for loose set screws or any type of damage. If the coupling checks good, the tach. is usually bad. If the board voltage output is unsteady beyond limits, then the board is probably bad. Always check the speed pot. Be sure it is okay before

		changing a board or tach. This test is not always 100% accurate as this test is not performed at operating speeds. However, this test is the best method currently available. Readjustment should always be attempted at least once before replacement. See procedure for board adjustment in Section D.
	DC Gearmotor	If the problem seems to be the motor or gearbox. Check the brushes in the motor for excessive arcing and/or unusual wear. Check the motor and gearbox from instructions located under "possible cause" listing "Conveyor gear motor".
Time/Temp Display inoperative	12.6 VAC Power Supply	Measure the transformer primary for a nominal 120 VAC input. If 120 VAC primary voltage is not available, refer to the schematic and trace the circuit for incoming power failure
S/N 2011821 & Above Refer to Page 45		Measure the secondary voltage output which will be 12.5 to 15 VAC normally. Recheck secondary output at rear of Time/Temp Display. Terminals 1 to 3 should read 12.5 to 15 VAC. Terminals 1 to 2 and 2 to 3 should be 1/2 of the reading across 1 to 3. If you do not get the above secondary readings, replace the transformer. The older units have a 4 amp ambient fuse in each red secondary lead. These may be jumpered to determine if they are burnt out or intermittent.
Temp Display out or erratic	NOTE: Time/Temp displays uses two types of temperature sensor, Thermistor Probe - 2 yellow wires, Thermocouple Probe - 1 red wire and 1 white wire	Insert the thermocouple of your pyrometer into a finger hole in the top center of the oven. The thermocouple tip should measure air temperature and must not be touching metal.
	Thermistor Probe	Disconnect the yellow tipped thermistor leads from the time/temp. terminals 9 & 10 Measure the resistance of the thermistor probe See the chart in Section D for proper resistance readings. Inspect the thermistor bulb for its proper location in its spring holder. Check for short in leads where they enter the sensor bulb. Also check each thermistor lead for short to ground.
	Thermocouple Probe	Connect temperature meter to thermocouple at terminals 9 and 10 on back of the time/temp display. (Be sure to maintain proper polarity on thermocouple connections.) Compare actual oven temperature with the reading at the time/temp display. If the temperature readings match, re-calibrate or replace time/temp

	<p>Power Supply</p>	<p>display. If the readings do not match, replace thermocouple probe.</p> <p>If strange or unusual behavior is experienced such as a rolling of numbers, or lock up at a given number, first check for a display circuit lock up. This can be caused by a voltage spike or surge in the incoming power lines. To eliminate this condition remove power from the time/temp. display by shutting off the main fan switch for 15 seconds, or if display stays on, (older models) circuit breaker interruption may be required. This should eliminate the problem. If the problem continues, jumper the two fuses in the red wires leading from the 12.6 VAC transformer to the display on older units. If this does not solve the problem, it may be coming in through the commercial power lines. Suggest that customer contact his power company for evaluation.</p>
	<p>Temp Display inaccurate, erratic, or inoperative</p>	<p>Perform the power supply check, the thermistor probe check, and then perform the time/temp simulator test. Refer to Section D for instructions. Remember, when using the time/temp simulator, remove all the leads from the back of the display except the 3 power leads. After completion of this test and if reinstalling display back into the oven, the dip switches must be reset for oven operation.</p>
<p>S/N 2011821 & Above, See Pg. 45</p>	<p>Time Display inaccurate, erratic, or inoperative</p>	<p>Perform all checks as in the above evaluation. If the time check is okay, refer to the next section - optical encoder.</p>
	<p>Optical Encoder</p>	<p>The above time/temp test should have already been performed. Remove the dust cover from the gearmotor and inspect the coupling and encoder disc. The coupling set screws should be tight and not slipping on the motor shaft or the tach. generator shaft. The encoder disc should be firmly attached to the coupling and not warped. Check the positioning of the optical encoder disc. The disc should not be touching the optical encoder assembly and the encoder assembly should be mounted so it is squarely facing the coupling shaft. This is to allow the infrared light beams to be broken by the encoder disc. If all this is okay, then replace the optical encoder assembly.</p>

TROUBLE SHOOTING GUIDE ELECTRIC OVENS

MODEL 1104	380/220 VAC	THREE PHASE	50 HZ
MODEL 1105	415/240 VAC	THREE PHASE	50 HZ
MODEL 1106	240 VAC	SINGLE PHASE	50 HZ

REFER TO PROPER SCHEMATIC FOR IDENTIFIED COMPONENTS

SYMPTON	POSSIBLE CAUSE	EVALUATION
Oven fan will not run	Incoming Power Supply	Check circuit breakers. Reset if required. Call Power Co. if needed.
	Fuse, 1 Amp, Fuseholder	Check, replace if necessary. Check, replace if necessary.
	Switch, Main Fan Transformer, Control	Check for continuity between switch terminals. 120 VAC \pm 10% should be present at secondary of transformer. If proper voltage is not present, check transformer primary for proper input. Replace as needed.
	Main Fan Relay	Check continuity to 120 VAC coil. Check for power to relay coil (120 VAC). Check for 220/240 VAC to the relay terminals. Check, replace if necessary.
No control box cooling	Fuse 10 A. Main Fan Fuse Holder Main Fan Motor	Check, replace if necessary. Check, replace if necessary. Check for opens, shorts, or grounds. WITH POWER OFF: Turn fan blade to check for locked rotor.
	Capacitor	Check for opens, shorts, or grounds. Check for main fan operation. If not operating, refer to "Oven fan will not run".
	Cooling Fan Motor	120 VAC should be present at the fan motor. If voltage is present, check for opens or shorts. WITH POWER OFF: Check for locked rotor on fan motor.
No main fan cool down	Cool Down Thermostat	Check cool down thermostat (thermostat closes at 160°F and opens at 140°F). Check for power (220/240 VAC) at cool down thermo stat. With cool down thermostat preheated, check for continuity. If switch is open, replace.
Oven will not heat	Main Fan Motor	Check for main fan operation. If it is not operating, refer to "Oven fan will not run".
	High Limit Thermostat,	Terminals are normally closed (open at 190°F). If open, reset the thermostat and test for proper operation. If it will not reset and hold, then replace.

Switch, Heat	With switch on, check for 120 VAC on both terminals to neutral. Replace if defective.
Air Pressure Switch	This normally open switch should close when the main fan is activated. Adjust if necessary (Refer to Section D). Replace if defective.
Fuse, 3 Amp	Check, replace if necessary.
Fuseholder	Check, replace if necessary.
Temperature Control	Check for 120 VAC supply at terminal #11 to neutral on temperature control. If no voltage is present, trace wiring back to 3 amp fuse. Turn the temperature adjustment knob to maximum temperature position and check for 120 VAC at the load terminal (#9) and neutral. If 120 VAC is present and unit is not heat -ing, refer to "Mercury Contactor" for next check. If 120 VAC is not present, proceed.
Thermocouple Probe	WITH POWER ON AND THERMOCOUPLE LEADS ATTACHED TO THE TEMPERATURE CONTROL BOARD: measure D. C. millivolt output of these leads. Refer to thermocouple chart in Section D for proper readings. If these readings are not achieved, replace thermocouple.
Temperature Control Potentiometer	WITH POWER OFF: remove the potentiometer leads from the temperature control board and measure ohms from black to white leads. The reading should be from approximately 0 to 2.5k ohms as the dial of the potentiometer is turned throughout its full rotation. From black to red leads, the reading should be approximately 2.5k ohms (constant) throughout the full rotation of the dial. If these readings are not achieved, replace potentiometer. If the thermocouple probe and the control potentiometer check good, then the problem is usually with the temperature control board.
Mercury Contactor	Check for 120 VAC to the contactor coil. If voltage is present and contact will not activate, replace the contactor. Also, check each contactor for proper high voltage input and output.
Heater Elements	Check the Amp. draw on each hot leg for proper load. Check the specifications plate for rating information. If the Amp. draw is low or high, check the individual elements for opens, shorts, and proper resistance. WITH POWER OFF: To check resistance of the elements, remove all leads from the elements and use an accurate digital VOM. The element resistance should be

Oven heats with switch off	Mercury Contactor	as follows: 220V - 30 ohms approximately 240V - 36 ohms approximately The mercury contactor has probably malfunctioned in the closed position. If there is no voltage to the operating coil, but there is high voltage at the contactor output, replace the mercury contactor.
Intermittent Heating	Thermal/Overload of motor	The main fan motor is equipped with internal thermal protection and will cease to operate if overheating occurs. As the motor overheats and then cools, this will cause the oven to cycle on and off intermittently. This may be caused by improper ventilation or preventative maintenance. Also, most of the problems listed under "Oven will not heat" can cause intermittent failure.
Conveyor will not run	REFER TO PAGE 31	
Conveyor speed varying or intermittent	REFER TO PAGE 32	
Time/Temp Display inoperative	REFER TO PAGE 33	
Temp Display out or inaccurate	REFER TO PAGE 33	

TROUBLE SHOOTING GUIDE

ELECTRIC OVENS

MODEL 1134	220/380 VAC	THREE PHASE	50 HZ
MODEL 1135	240/415 VAC	THREE PHASE	50 HZ
MODEL 1136	240 VAC	SINGLE PHASE	50 HZ
MODEL 1150	220/380 VAC	THREE PHASE	50 HZ

REFER TO PROPER SCHEMATIC FOR IDENTIFIED COMPONENTS

SYMPTON	POSSIBLE CAUSE	EVALUATION
Oven fan will not run	Incoming Power Supply	Check circuit breakers. Reset if required. Call Power Co. if needed.
	Fuse, 10 Amp, Main Fan Fuseholder	Check, replace if necessary.
	Fuse, 1 Amp, Transformer Fuseholder	Check, replace if necessary.
	Transformer, Control	Check, replace if necessary. 120 VAC \pm 10% should be present at secondary of transformer. If proper voltage is not present, check transformer primary for proper input. Replace as needed.
	Thermostat, High Limit, Oven Cavity	Terminals are normally closed. If open, reset the thermostat and test for proper operation. If it will not reset and hold, replace thermostat.
	Switch, Main Fan	Check for continuity between switch terminals.
	Relay, Oven Start	Check for continuity at relay coil, and visually check for pull in of contacts.
	20 Minute Time Delay	Check for 120 VAC at terminals #1 to neutral on 20 minute Time Delay Relay. If no voltage is present, trace wiring back to power source. If voltage is present at terminal #1, check for 120 VAC at terminal #2 to neutral. If no voltage is present, and oven start relay is closed, replace Time Delay.
	Main Fan Relay	Check continuity to 120 VAC coil. Check for power to relay coil (120 VAC). Check for 220/240 VAC to relay terminals.
	Main Fan Motor	Check for opens, shorts, or grounds. WITH POWER OFF: Turn fan blade to check for locked rotor.
No main fan cool down	Capacitor	Check for opens, shorts, or grounds.
	20 Minute Time Delay	Check for 120 VAC at terminal #2 to neutral while oven is "on". Turn off the main fan switch, 120 VAC should continue to be present for 20 minutes. If voltage is not present for approx. 20 minutes, replace the timer.

Main fan runs after 20 minute cool down	Oven Start Relay	Contacts should open when main fan switch is turned off.
	20 Minute Time Delay	120 VAC at terminal #2 should discontinue approximately 20 minutes after main fan is switched off. If the oven start relay contacts are open, and the voltage continues at terminal #2 of the 20 minute timer, for more than 20 mins., replace the timer.
	Oven Fan Relay	Check to insure that the contacts are opening after the coil is de-energized.
	20 Minute Time Delay	NOTE: ON/OFF operation of the fan switch will set the timer to 20 minutes. If the timer is accidentally reset, turn off main breaker for 15 seconds to cancel.
No control box cooling to "Oven Fan Will Not Run".	Oven Start Relay	Check for main fan operation. If not operating, refer Check relay contacts. 120 VAC should be present.
	Cooling Fan Motor(s)	120 VAC should be present at the fan motor. If voltage is present, check for opens or shorts. WITH POWER OFF: Check for locked rotor of the fan motor.
No automatic control Fan	Thermostat, Cooling Fan	Check the cooling fan thermostat. box cooling (Thermostat closes at 120°F and opens at 100°F.) With the cooling fan thermostat pre-heated, check for continuity. If switch is open, replace.
	Cooling Fan Motor(s)	120 VAC should be present at the fan motor. If voltage is present, check for opens or shorts. WITH POWER OFF: Check for locked rotor of the fan motor.
Control box cooling fan continues to run	Thermostat, Cooling Fan	This normally open thermostat should close at 120°F (48.9°C) and reopen at 100°F (37.8°C).
Oven will not heat	Main Fan Motor	Check for main fan operation. If it is not operating, refer to "Oven fan will not run".
	Heat Switch both terminals to neutral.	With switch on, check for 120 VAC on Replace if defective.
	Air Pressure Switch	This normally open switch should close when the main fan is activated. Adjust if necessary (Refer to Section D). Replace if defective.
	Fuse, 3 Amp	Check, replace if necessary.
	Fuseholder	Check, replace if necessary.
	Temperature Control	Check for 120 VAC supply at terminal #11 to neutral on temperature control. If no voltage is present, trace wiring back to 3 amp fuse. Turn the temperature adjustment knob to maximum temperature position and check for 120 VAC at the load terminal (#9) and neutral. If 120 VAC is present and unit is not heating, refer to "Mercury Contactor" for next check. If 120 VAC is not present, proceed.
	Thermocouple Probe	WITH POWER ON AND THERMOCOUPLE LEADS ATTACHED TO THE TEMPERATURE CONTROL BOARD: measure D. C.

		LEADS ATTACHED TO THE TEMPERATURE CONTROL BOARD: measure D. C. millivolt output of these leads. Refer to thermocouple chart in Section D for proper readings. If these readings are not achieved, replace thermocouple.
	Temperature Control Potentiometer	WITH POWER OFF: remove the potentiometer leads from the temperature control board and measure ohms from black to white leads. The reading should be from approximately 0 to 2.5k ohms as the dial of the potentiometer is turned throughout its full rotation. From black to red leads, the reading should be approximately 2.5k ohms (constant) throughout the full rotation of the dial. If these readings are not achieved, replace potentiometer. If the thermocouple probe and the control potentiometer check good, then the problem is usually with the temperature control board.
	Mercury Contactor	Check for 120 VAC to the contactor coil. If voltage is present and contactor will not activate, replace the contactor. Also, check each contactor for proper high voltage input and output.
	Heater Elements	Check the Amp. draw on each hot leg for proper load. Check the specifications plate for rating information. If the Amp. draw is low or high, check the individual elements for opens, shorts, and proper resistance. WITH POWER OFF: To check resistance of the elements, remove all leads from the elements and use an accurate digital VOM. The element resistance should be as follows: 220V - 30 ohms approximately 240V - 36 ohms approximately
Oven heats with switch off	Mercury Contactor	The mercury contactor has probably malfunctioned in the closed position. If there is no voltage to the operating coil, but there is high voltage at the contactor output, replace the mercury contactor.
Intermittent Heating	Thermal/Overload	The main fan is equipped with internal of motor thermal protection and will cease to operate if overheating occurs. If the motor overheats and then cools, this will cause the unit to cycle on and off intermittently. This may be caused by improper ventilation or preventative maintenance. Also, most of the problems listed under "Oven will not heat" can cause intermittent failure.

Conveyor will not run	REFER TO PAGE 31
S/N 2011383 and above	REFER TO PAGE 45
Conveyor speed varying or intermittent	REFER TO PAGE 32
S/N 2011383 and above	REFER TO PAGE 45
Time/Temp. Display inoperative	REFER TO PAGE 33
S/N 2011383 and above	REFER TO PAGE 45
Temp. Display out or inaccurate	REFER TO PAGE 34
S/N 2011383 and above	REFER TO PAGE 45

TROUBLESHOOTING GUIDE ELECTRIC OVEN

MODEL 1151 200 VAC THREE PHASE 60 HZ

REFER TO PROPER SCHEMATIC FOR IDENTIFIED COMPONENTS

SYMPTON	POSSIBLE CAUSE	EVALUATION
Oven fan will not run	Incoming Power Supply	Check circuit breakers. Reset if required. Call Power Co. if needed.
	Fuses, 10 Amp, Main Fan Fuseholder	Check, replace if necessary.
	Fuses, 1 Amp, Transformer Fuseholder	Check, replace if necessary.
	Transformer, Control	Check, replace if necessary.
	Thermostat, High Limit, Oven Cavity	120 VAC \pm 10% should be present at secondary of transformer. If proper voltage is not present, check transformer primary for proper input. Replace as needed. Terminals are normally closed. If open, reset the thermostat and test for proper operation. If it will not reset and hold,
	replace thermostat.	
	Switch, Main Fan Relay, Oven Start	Check for continuity between switch terminals. Check for continuity at relay coil, and visually check for pull in of contacts.
	20 Minute Time Delay	Check for continuity at relay coil, and visually check for pull in of contacts. Check for 120 VAC at terminals #1 to neutral on 20 minute Time Delay Relay. If no voltage is present, trace wiring back to power source. If voltage is present at terminal #1, check for 120 VAC at terminal #2 to neutral. If no voltage is present, and Main Fan Switch is closed, replace Time Delay.
	Main Fan Relay	Check for 120 VAC to coil of the Relay. If no voltage is present, trace wiring back to 20 minute Time Delay Relay. If voltage is present, check to insure contacts are closing.
	Main Fan Motor	Check for opens, shorts, or grounds. WITH POWER OFF: Turn fan blade to check for locked rotor.
No main fan cool down	Capacitor	Check for opens, shorts, or grounds.
	20 Minute Time Delay	Check for 120 VAC at terminal #2 to neutral while oven is "on". Turn off the main fan switch, 120 VAC should continue to be present for 20 minutes. If voltage is not present for approximately 20 minutes, replace the timer.

Main fan continues to run after cool down	Relay, Main Fan	Check if relay is operating and that the contacts remain closed during the 20 minute cool down.
	20 Minute Time Delay	NOTE: ON/OFF operation of fan switch will set the timer to 20 minutes. If the timer is accidentally reset, turn off main breaker for 15 seconds to cancel. If 120 VAC continues to be present at terminals 2 and 3 after 20 minutes, replace the timer.
No control box cooling	Relay, Main Fan	Relay Contacts should open when the relay coil is de-energized.
	Main Fan	Check for main fan operation. If not operating, refer to "Oven Fan Will Not Run".
No automatic control	Relay, Oven Start	Check relay contacts. 120 VAC should be present.
	Cooling Fan Motor	120 VAC should be present at the fan motor. If voltage is present, check for opens or shorts.
	Thermostat, Cooling Fan	WITH POWER OFF: Check for locked rotor of the fan motor.
Control box cooling fan continues to run	Thermostat, Cooling Fan	Check the cooling fan thermostat. box cooling (Thermostat closes at 120°F and opens at 100°F.)
	Cooling Fan Motor	With the cooling fan thermostat pre-heated, check for continuity. If switch is open, replace.
Oven will not heat	Thermostat, Cooling Fan	120 VAC should be present at the fan motor. If voltage is present, check for opens or shorts.
	Main Fan Motor	WITH POWER OFF: Check for locked rotor of the fan motor.
Oven will not heat	Switch, Heat	This normally open thermostat should close at 120°F (48.9°C) and reopen at 100°F (37.8°C).
	Air Pressure Switch	Check for main fan operation. If it is not operating, refer to "Oven fan will not run".
Oven will not heat	Temperature Control	With switch on, check for 120 VAC on both terminals to neutral. Replace if defective.
	Thermocouple Probe	This normally open switch should close when the main fan is activated. Adjust if necessary (Refer to Section D). Replace if defective.
Oven will not heat	Temperature Control	Check for 120 VAC supply at terminal #11 to neutral on temperature control.
	Temperature Control Potentiometer	Turn the temperature adjustment knob to maximum temperature position and check for 120 VAC at the load terminal (#9) and neutral. If 120 VAC is present and unit is not heating, refer to "Mercury Contactor" for next check.
Oven will not heat	Temperature Control Potentiometer	If 120 VAC is not present, proceed.
	Temperature Control Potentiometer	WITH POWER ON AND THERMOCOUPLE LEADS ATTACHED TO THE TEMPERATURE CONTROL BOARD: measure D. C. millivolt output of these leads. Refer to thermocouple chart in Section D for proper readings. If these readings are not achieved, replace thermocouple.
Oven will not heat	Temperature Control Potentiometer	WITH POWER OFF: remove the potentiometer leads from the
	Temperature Control Potentiometer	

		temperature control board and measure ohms from black to white leads. The reading should be from approximately 0 to 2.5k ohms as the dial of the potentiometer is turned throughout its full rotation. From black to red leads, the reading should be approximately 2.5k ohms (constant) throughout the full rotation of the dial. If these readings are not achieved, replace potentiometer. If the thermocouple probe and the control potentiometer check good, then the problem is usually with the temperature control board.
	Mercury Contactor	Check for 120 VAC to the contactor coil. If voltage is present and contactor will not activate, replace the contactor. Also, check each contactor for proper high voltage input and output.
	Heater Elements	Check the Amp. draw on each hot leg for proper load. Check the specifications plate for rating information. If the Amp. draw is low or high, check the individual elements for opens, shorts, and proper resistance. WITH POWER OFF: To check resistance of the elements, remove all leads from the elements and use an accurate digital VOM. The element resistance should be as follows: 200V - 24.5 ohms approximately
Oven heats with switch off	Mercury Contactor	The mercury contactor has probably malfunctioned in the closed position. If there is no voltage to the operating coil, but there is high voltage at the contactor output, replace the mercury contactor.
Intermittent Heating	Thermal/Overload of motor	The main fan motor is equipped with internal thermal protection and will cease to operate if overheating occurs. If the motor overheats and then cools, this will cause the oven to cycle on and off intermittently. This may be caused by improper ventilation or preventative maintenance. Also, most of the problems listed under "Oven will not heat" can cause intermittent failure.
Conveyor will not run		REFER TO PAGE 31
S/N 2011383 and above		REFER TO PAGE 45
Conveyor speed varying or intermittent		REFER TO PAGE 32
S/N 2011383 and above		REFER TO PAGE 45
Time/Temp. Display inoperative		REFER TO PAGE 33

S/N 2011383 and above

REFER TO PAGE 45

Temp. Display out or inaccurate

REFER TO PAGE 33

S/N 2011383 and above

REFER TO PAGE 45

STEPPER MOTOR DRIVE

Conveyor will not run

Conveyor Switch

Check for 120 VAC to conveyor switch. If no voltage is present, trace wiring back to the oven power source.

WITH POWER OFF:

Check continuity between switch terminals.

Conveyor Fuse 3AMP

Check, replace if necessary. (Not used on Model 1151)

Fuseholder

Check, replace if necessary.

Conveyor Control

Check for 120 VAC supply to primary of transformer, if voltage is not present, trace wiring back to the fuseholder. If voltage is present, check for output voltage from the transformer secondary. NOTE: This control transformer outputs (2) secondary voltages.

(Stepper) Transformer

Red Leads 29 VAC

Brown Leads 10 VAC

If BOTH secondary voltages are not present, replace the transformer.

Speed Adjustment Potentiometer

This is a 0 to 50k ohm, 10 turn potentiometer WITH POWER OFF: remove the 3 pin potentiometer cable plug from the motor control board. With a digital multimeter, check the ohm reading across the red lead to the black lead, this reading should be 50k ohms \pm 5% as the potentiometer is rotated through its 10 turn rotation. Place the meter leads on the red lead and white lead. Rotating the potentiometer slowly, from low to high, the meter should show an even transition from 0 to 50k ohms \pm 5% through the 10 turn rotation of the potentiometer. There should be no dead or open spots through the 10 turns of the potentiometer. Check all three leads to ground. There should be no continuity to ground.

If any of the above checks fail, replace the potentiometer.

Conveyor Motor (Stepper) Control

NOTE: if the conveyor drive motor becomes jammed, the motor will stop turning. To reset, turn off conveyor switch, wait 10 seconds and turn the conveyor switch on.

If the motor does not run, check for 2 to 29 VAC across the motor terminals 1 to 2 and 3 to 5 on the conveyor motor control. If voltage is not

	Conveyor Drive (Stepper) Motor	present at both sets of terminals, replace control. Check the drive sprocket on motor output shaft to insure that it is tight. WITH POWER OFF: Turn the motor shaft to check for jammed gear box. Check motor windings. Ohm readings on motor terminal - 1-5, 2-6, 3-7, 4-8, each reading should be approximately 2 ohms. If motor shaft will not turn, replace conveyor drive (stepper) motor.
Time/Temp Display inoperative	12 VAC Power Supply (Transformer)	Measure the transformer primary for a nominal 120 VAC input, if voltage is not present, trace wiring back to the oven power source. Measure the secondary output, which will normally be 12-15 VAC. Voltage across terminals 1 and 3 on the time/temp. display should read 12-15 VAC. Terminals 1-2 and 2-3 should be 1/2 the voltage reading to 1-3. If the above secondary readings are not achieved, replace transformer.
	Time/Temp Display	If proper voltage is present at terminals 1, 2, and 3 on time/temp display, but the display is not lighted, recheck all connections for tightness. If time/temp display is still not operating, replace the time/temp display.
Temp display out or inaccurate	NOTE: Time/Temp displays use two types of temperature sensors, thermistor probe-2 yellow wires, thermocouple probe probe-1 red wire and 1 white wire Thermistor Probe	Place the thermocouple of a pyrometer into the center of the top finger. Be sure the tip of the thermocouple is not touching metal. The pyrometer will indicate oven temperature.
	Thermocouple Probe	Disconnect the thermistor probe leads from the time/temp display terminals #9 and 10. Measure the resistance of the thermistor probe. See chart in section D, showing probe resistance at various oven temperature. If these readings are not achieved, replace the thermistor probe. Place your pyrometer thermocouple into the center of the top finger. Measure D.C. millivolts at terminals 9 and 10 on the time/temp display. See thermocouple chart in Section D for proper readings. Connect temperature meter to thermocouple at terminals 9 & 10 on back of the time/temp display. (Be sure to maintain proper polarity on thermocouple connections.) Compare actual oven temperature with the reading at the time/temp display. If the temperature readings match, recalibrate or replace time/temp display. If the readings do not match, replace thermocouple probe.
	Power Supply	If a strange or unusual behavior is

Temp display inaccurate, erratic, or inoperative	Time/Temp Display	<p>experienced, such as a rolling of numbers, or lock-up at a given number, first check for a display circuit lock-up. This may be caused by a voltage spike or surge in the incoming power lines. To eliminate this condition, remove power from the time/temp display by shutting off the main fan switch for 15 seconds. This should eliminate the problem. If this does not solve the problem, it may be coming in through the Commercial power lines. Suggest that customer contact their power company for evaluation. Perform the power supply check, the thermistor probe check, and then perform the time/temp simulator test. Refer to Section D for instructions. Remember, when using the time/temp simulator, remove all leads from the back of the time/temp display except the 3 power leads.</p> <p>After completion of the test, and if re-installing time/temp display back in the oven, the dip switches must be reset for oven operation, and the time/temp display must be recalibrated. If readings are not achieved, replace display.</p>
Time Display inaccurate, erratic, or inoperative	Conveyor Drive (Stepper) Motor	<p>Perform all checks as in the above evaluation. If the time check is okay, refer to the next section.</p>
	Magnet	<p>Check to see if the conveyor drive (stepper) motor is running. If motor is not running, refer to "Conveyor will not run" on Page 45.</p> <p>Check to insure that the magnet (cemented to shaft of conveyor drive [stepper] motor) has not been damaged, or come loose from motor shaft. Replace as needed.</p>
	Hall Effect Sensor	<p>Check for any physical damage to Hall Effect sensor (mounted on conveyor drive [stepper] motor). Check all wiring and connections for damage. If the motor is running, the magnet is in place, but the display shows"—:—" the Hall Effect Sensor may be defective or improperly connected.</p>
	Conveyor Drive (Stepper Control)	<p>Check all connections for tightness or proper location and check all wiring for visible damage. Replace as needed. If there is still no time display and all the above have checked out, replace the stepper control.</p>

REMOVAL, INSTALLATION, AND ADJUSTMENT IMPINGER II CONVEYOR OVEN

MOTOR, MAIN FAN

1. Shut off power at main breaker.
2. Disconnect motor wiring of main fan motor, note wire colors for reassembly, and remove entire oven back from the oven. Refer to "main fan" (See Below) for removal information.
3. Remove the main fan.
4. Remove 4 screws from the motor support assembly.
5. Remove the motor mounting clamp and pull the motor away from the oven back assembly.
6. Remove motor mounting fixture.
7. Install the motor in reverse order insuring that the motor shaft is centered in the
8. Shaft tube of the oven back.

CAPACITOR, MOTOR

Model 1100-1106

Capacitor is located under motor cover in rear of unit and held in place by a plastic wire tie.

- 1 Discharge capacitor, remove and replace.

FOR ALL OTHER 1100 MODELS

Capacitor is located under rear control box cover and held in place by a plastic wire tie.

MAIN FAN

1. Shut off power at main breaker.
2. Remove motor cover from back of oven.
3. Disconnect and mark motor wiring of main fan motor and remove entire oven back from oven.
NOTE: Turning the oven back bolts back and forward while applying a spray lubricant or penetrating oil will help minimize breakage.
4. Loosen and remove set screw in hub of fan.
5. Remove fan. The motor shaft has a flat making removal of fan fairly easy. If trouble is encountered, apply a spray lubricant or penetrating oil in set screw hole and on motor shaft.
NOTE: This fan is balanced by the manufacturer and must be handled carefully.
Suggested storage is by suspending the fan through the shaft hole.
6. Reinstall fan with the tips of the fan blade closest to the oven back.
7. Position of the fan on the motor shaft will be 1 1/2" (3.81cm) from the top of the oven back cone to the bottom of the fan hub. Refer to drawing. The oven back must be removed to make this measurement.
8. Align set screw with motor shaft flat and tighten.
9. Reassemble in reverse order.

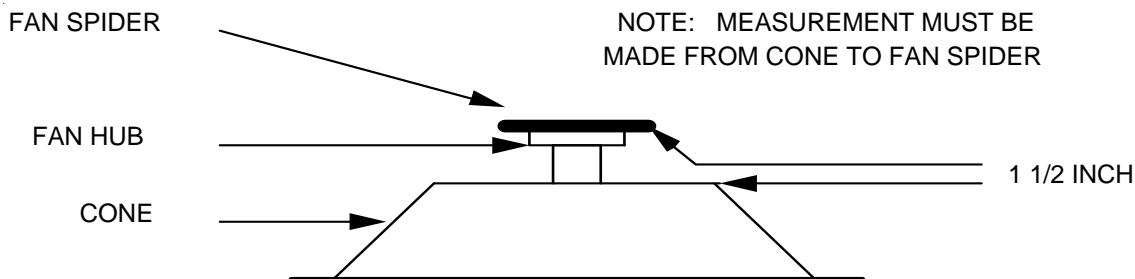

RELAY, DPST

1. Shut off power at main breaker.
2. Remove conveyor.
3. Remove control compartment covers.
4. Remove leads from relay and mark for reassembly.
5. Remove mounting screws and lift out relay.
6. Reassemble in reverse order.

TIME DELAY, 20 MINUTE

1. Shut off power at main breaker.
2. Remove conveyor.
3. Remove front control compartment cover.
4. Unplug all wires and mark for replacement.
5. Remove center mounting screw.
6. Reassemble in reverse order.

NOTE: Do not overtighten the mounting screw as this may damage the internal potted electronic components.

COOLING FAN

1. Shut off power at main breaker.
2. Remove conveyor.
3. Remove front control compartment cover.
4. Remove 4 screws from fan frame.
5. Remove fan and unplug female cord receptacle.
6. Reassemble in reverse order.

NOTE: All current models have 2 of these cooling fans.

7. The second cooling fan is located in the rear of the rear control compartment. On older models of the 1116, 1117, 1152 through 1158 the fan was attached to a metal box on rear of oven. Metal box was removed first. Newer ovens have fan mounted on inside of oven back and are removed from inside.

THERMOSTAT, COOL DOWN

Model 1100-1106 only

1. Shut off power at main breaker.
2. Remove conveyor.
3. Remove control compartment covers.
4. Remove 2 screws from holding bracket located in upper rear of the control compartment.
5. Remove the 2 leads and remove thermostat.
6. Reassemble in reverse order.

RELAY, DPST

1. Shut off power at main breaker.
2. Remove conveyor.
3. Remove front control compartment cover.
4. Remove leads and mark for reassembly.
5. Loosen mounting screws and remove.
6. Reassemble in reverse order.

THERMOSHETAT, COOLING FAN

1. Shut off power at main breaker.
2. Remove conveyor.
3. Remove front control compartment cover.
4. Remove lead wires and mark for reassembly.
5. Remove 2 screws and remove thermostat.
6. Reassemble in reverse order.

MOTOR, BURNER BLOWER

This unit comes equipped to be used for other models of ovens. For use on the Impinger II Series, the mating plug with the loose wires may be discarded.

TO REMOVE BLOWER MOTOR:

1. Shut off power at main breaker.
2. Remove conveyor.
3. Remove control compartment covers.
4. Disconnect the plug on blower motor. Plastic locks on side of plug need to be depressed.
5. Remove three screws holding blower horn to burner.
6. Remove air shutter from old unit and install on new unit. If air shutter of old unit is damaged or lost, replace with new air shutter [369401](#).
7. Reassemble in reverse order.
8. Adjust air shutter opening if necessary. Set air shutter at 50% open and adjust to get a blue flame with an occasional tip of yellow under high flame. A glass view port in the burner assembly should be used to observe flame.

CLEANING OF THE BLOWER FAN IS NECESSARY ON A PREVENTIVE MAINTENANCE SCHEDULE.

See Blower Wheel, Burner below

BLOWER WHEEL, BURNER

This is part of the burner blower motor assembly

TO REMOVE THE BLOWER WHEEL FOR PERIODIC CLEANING:

1. Disconnect power and remove control compartment covers.
 2. Remove air shutter held by 3 screws.
 3. Loosen set screw on blower wheel hub and pull straight out.
 4. Reassemble in reverse order.
- NOTE: There is no critical placement of the blower wheel on the motor shaft. Just back as far as it will go and then spin the blower to be sure it is not rubbing.

AIR PRESSURE SWITCH

1. Shut off power at main breaker.
 2. Remove conveyor.
 3. Remove front control compartment cover.
 4. Remove air switch cover plate.
 5. Disconnect wiring and mark for reassembly.
 6. Loosen 2 screws and remove air switch.
 7. Disconnect 1/4" air tube.
 8. Reassemble in reverse order.
 9. Turn on power and calibrate air switch as follows:
 - a) Turn adjusting screw counter clockwise to full out position.
 - b) Turn main fan and heat switch on.
 - c) Turn adjusting screw clockwise until heat shuts off.
 - d) Turn adjusting screw (counterclockwise) 1/4 turn and unit should heat.
- NOTE: Test as follows
- e) Oven must be tested in heated condition.
 - f) Remove main fan fuse. Main fan should shut down, deactivating air switch causing heat to shut off in approximately 5 to 25 seconds.
 - g) Fine tune adjustment as needed.

TEMPERATURE CONTROL BOARD

NOTE: If your unit contains a Fenwal temperature control board, (see below) replace it with a thermologic control board.

TEMPERATURE CONTROL BOARD CONVERSION - FENWAL TO THERMOLOGIC (FOUND ONLY IN ELECTRIC UNITS BELOW S/N 2000861)

1. Remove Fenwal board.
 2. Remove 5K ohm potentiometer
 3. Remove wire #63 from oven. This wire is connected to Fenwal board at terminal #5.
 4. Install new thermologic board with 2 screws.
 5. Install new 2.5K ohm potentiometer.
 6. Attach leads to thermologic board as shown in drawings. See Page D5.
1. Located in control compartment below drive end of the conveyor
 2. Shut off power at main breaker and remove conveyor.
 3. Remove front control compartment cover.
 4. Remove the two mounting screws.
 5. Remove the electrical leads and replace the control board.
 6. Identify the style of thermologic board by looking at the top of the transformer on the board. There are five styles of boards, each identified by a color marked on the transformer, either RED, BLUE, GREEN, GOLD, OR A SILVER DOT. Refer to Page D5 showing proper wiring connection.

NOTE:When mounting a new temperature control board, DO NOT overtighten the two mounting screws.
 7. Turn the potentiometer fully counterclockwise.
 8. Loosen the Dial/Knob set screw and position the 50°F mark at the pointer.

NOTE: The thermocouple of your test meter should be inserted through a finger hole in the top center of the oven, and the oven pre-heated for 30 minutes to stabilize the oven at set temperature. The thermocouple probe must not touch metal, it must sense air temperature only.
 9. Adjustment of the GREEN, GOLD OR SILVER dot control board may be required when installing a new board. Adjustment is seldom required on RED and BLUE boards.
 - a) For RED or BLUE control boards with the temperature control dial at maximum, the reading on your temperature test meter should be between 555°F (290°C) and 575°F (302°C). If not at this temperature adjust pot P3 to achieve these figures. Refer to Page D5.

- a) For the GREEN, GOLD OR SILVER dot control board, place the test probe of your meter in position as indicated in prior note. Set the oven temperature control dial 500°F(260°C), adjust pot P6 (see Page D8) to achieve a temperature reading on test meter of 500°F(260°C). CCW to increase, CW to decrease.
10. Adjust Time/Temp Display Pot. "Temp Cal" for 500°F(260°C).

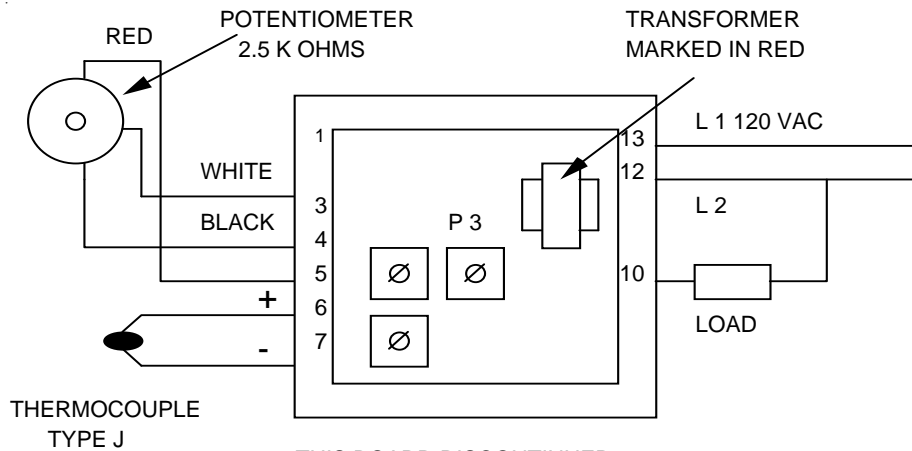
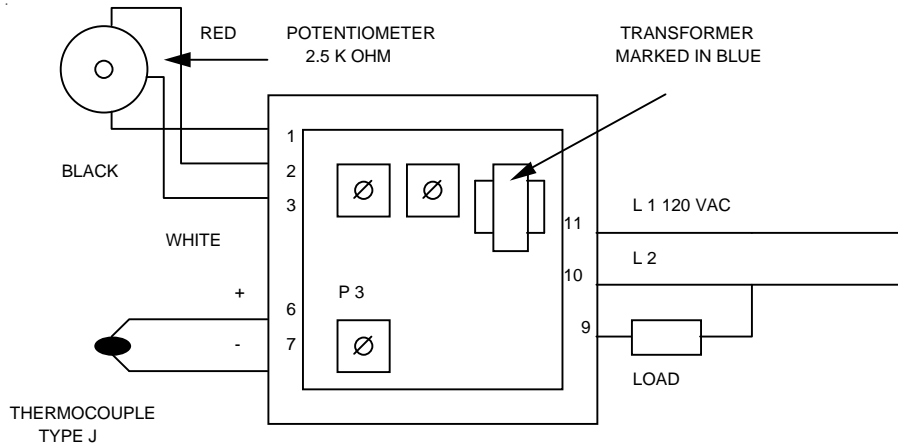
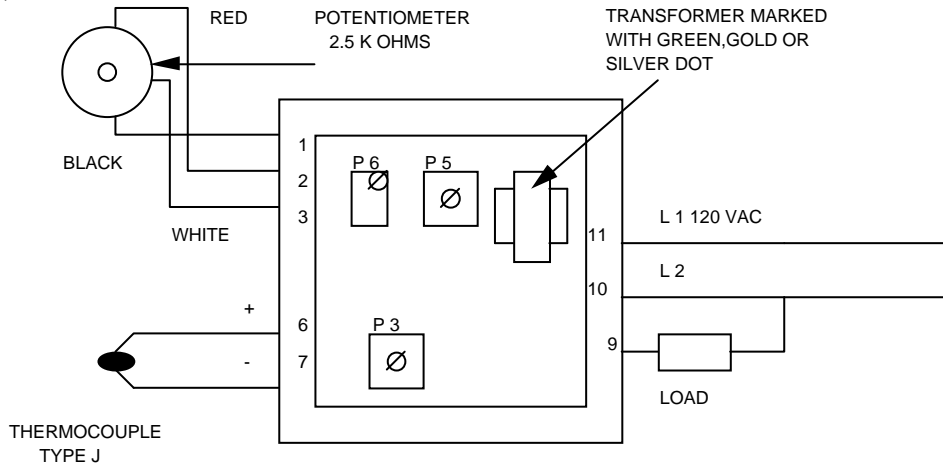

THIS BOARD DISCONTINUED
AT S/N 2000932

TEMPERATURE CONTROL POTENTIOMETER, 0-2.5K OHMS, 1 TURN

1. Shut off power at main breaker.
2. Remove front control box cover.
3. Loosen and remove temperature control knob.
4. Remove hex nut and washer then remove pot from rear of compartment.
5. Remove and mark wiring for replacement.
6. Replace in reverse order.
7. Recalibrate the dial. (See "Temperature Control")

THERMOCOUPLE PROBE

The sensor bulb is located in the oven compartment behind the lower finger, and held in position by a wire form holder.

CAUTION: ALLOW OVEN TO COOL

1. Shut off power.
2. Remove conveyor and lower finger.
3. Remove control compartment covers
4. Remove sensor bulb from the wire form holder, pull thermocouple out of the oven through the access tube and disconnect leads from terminals 6 and 7 of the temperature control board.
5. To install, push thermocouple bulb through the access tube and place in wire form holder. Be sure that wire form holder is exerting enough pressure on the sensor bulb to hold it in place. If sensor bulb is not held securely, replace the wire form holder or bend the holder slightly to hold sensor bulb in place.
6. Reconnect RED lead to terminal 7(-) and WHITE lead to terminal 6(+).
7. Replace conveyor and fingers.

THERMOCOUPLE MEASUREMENT CHART:

EXPLANATION: The junction temperature is the ambient air temperature where the thermocouple fastens to the electronic temperature control board.

		O	V	E	N	T	E	M	P			
		200°F	250°F	300°F	325°F	350°F	400°F	425°F	450°F	500°F	550°F	600°F
J U N C T I O N	90°F	3.26	4.77	6.30	7.06	7.83	9.37	10.14	10.91	12.46	14.00	15.53
	88°F	3.32	4.83	6.36	7.12	7.89	9.43	10.20	10.97	12.51	14.05	15.59
	86°F	3.37	4.88	6.41	7.17	7.94	9.49	10.26	11.03	12.57	14.11	15.65
	84°F	3.43	4.94	6.47	7.23	8.00	9.54	10.31	11.09	12.63	14.19	15.71
	82°F	3.49	5.00	6.53	7.29	8.06	9.60	10.37	11.14	12.69	14.23	15.76
	80°F	3.55	5.06	6.59	7.35	8.12	9.66	10.43	11.20	12.74	14.28	15.82
	78°F	3.60	5.11	6.64	7.40	8.17	9.72	10.49	11.26	12.80	14.34	15.86
	76°F	3.66	5.17	6.70	7.46	8.23	9.77	10.55	11.32	12.86	14.40	15.94
	75°F	3.69	5.20	6.73	7.49	8.26	9.80	10.57	11.35	12.89	14.43	15.97
	74°F	3.72	5.23	6.76	7.52	8.29	9.83	10.60	11.37	12.92	14.46	15.99
T E M P	72°F	3.78	5.29	6.82	7.58	8.35	9.89	10.66	11.43	12.97	14.51	16.05
	70°F	3.83	5.34	6.87	7.63	8.40	9.95	10.72	11.49	13.03	14.57	16.11
	68°F	3.89	5.40	6.93	7.69	8.46	10.00	10.78	11.55	13.09	14.63	16.17
	66°F	3.95	5.46	6.99	7.75	8.52	10.06	10.83	11.61	13.15	14.69	16.23
	64°F	4.01	5.52	7.05	7.81	8.58	10.12	10.89	11.66	13.20	14.74	16.28
	62°F	4.06	5.57	7.10	7.86	8.63	10.18	10.95	11.72	13.26	14.80	16.34
	60°F	4.12	5.63	7.16	7.92	8.69	10.24	11.01	11.78	13.32	14.86	16.40

MERCURY CONTACTOR

1. Shut off power at the main breaker.
2. Remove conveyor.
3. Remove control compartment covers.
4. Disconnect contactor wires and mark for reinstallation.
5. Remove screws from mounting bracket and replace contactor.
NOTE: Be sure contactor is not mounted upside down at this will cause a constant on condition.
6. Reassemble in reverse order.

GAS VALVE

1. Shut off power at main breaker.
2. Shut off the gas supply in the main line to the oven.
3. Disconnect the flexible gas hose.
4. Remove the control compartment covers.
5. Remove the manual gas shut off valve from piping.
6. Remove screws from the bulkhead plate located on rear of oven at the gas pipe.
7. Remove the section of gas pipe to gas valve.
8. Disconnect the electrical leads from the solenoid valve.
9. Loosen the gas line union located near the burner and remove the gas valve and solenoid valve assembly.
10. Finish removal of the gas piping from gas valve.
11. Replace in reverse order.
12. Check all gas fittings for leaks.
13. Adjust the gas manifold pressure on the gas valve. "Refer to the specification plate on the oven for proper rating".

SOLENOID VALVE

1. Shut off power at main breaker.
2. Shut off gas supply.
3. Remove rear control box cover.
4. Disconnect wires from solenoid valve. Mark wires for reassembly.
5. Loosen pipe union in piping assembly.
6. Remove 4 nuts from burner manifold and remove valve assembly.
7. Remove piping from solenoid valve.
8. Reassemble in reverse order.
NOTE: Some piping changes may be required. See instructions supplied with replacement part.

HEATING ELEMENTS

1. Shut off power at main breaker.
2. Remove back cover.
3. Disconnect heater element wire and mark for reassembly.
4. Disconnect motor wiring and mark for reassembly.
5. Remove oven back from oven.
6. Remove fan shroud.
7. Heater element may now be unbolted and removed.
8. Check heater elements to be sure they are the proper replacement.
9. Reassemble in reverse order.
NOTE: Be sure the lead terminals are tight.

IGNITION CONTROL

1. Shut off power at main breaker.
2. Shut of the gas supply in the main line to the oven.
3. Remove conveyor.
4. Remove the front control compartment cover.
Note: After S/N 2011383 a removable drip tray is located above the ignition control.
5. Disconnect the wires from the ignition control and mark their location for reinstallation.
6. Remove the 4 mounting screws and remove the control.
7. Reassemble in reverse order.
8. Turn on electrical power and gas supply, then check the system for proper operation.

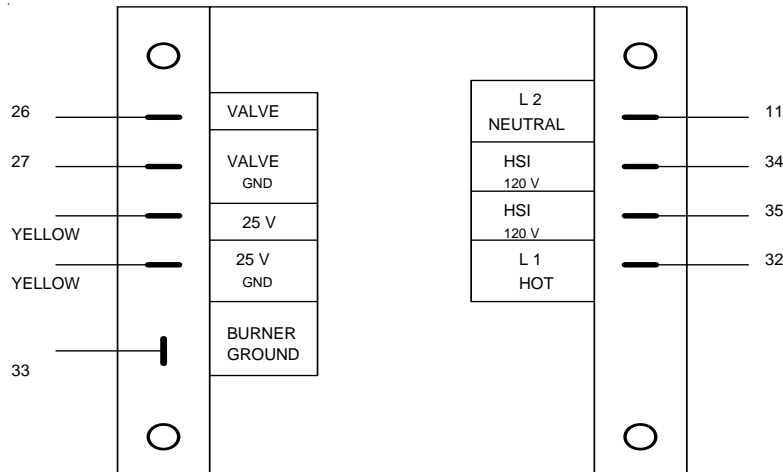

IGNITION CONTROL

TRANSFORMER, STEP DOWN 24 VAC

1. Shut off power at the main breaker.
2. Remove conveyor.
3. Remove front control compartment cover.
4. Remove wires from transformer and mark for reassembly.
5. Remove 2 mounting screws and replace transformer.
6. Reassemble in reverse order.

BURNER VENTURI

See "Hot Surface Igniter"

HOT SURFACE IGNITER

1. Shut off the electrical power at main breaker.
2. Shut off the gas supply in the main line to the oven.
3. Remove conveyor.
4. Remove rear control compartment cover.
5. Remove Conveyor Motor.
6. Remove electrical plug from the burner cap.
7. Loosen the pipe union in the gas line.
8. Remove 3 screws holding burner cap to burner tube.
9. Pull out on burner cap removing cap and burner venturi.
10. The hot surface igniter is held in place on the burner venturi by a screw, loosen screw and remove igniter.
11. Replace in reverse order.

NOTE: Care must be used when handling the hot surface igniter as they are quite fragile and may be easily broken if dropped or bumped.

ORIFICE, MAIN BURNER

1. Shut off power at main breaker.
2. Shut off gas at main line to the oven.
3. Remove conveyor.
4. Remove control compartment covers.
5. Loosen 4 nuts holding manifold to burner cap.
6. Loosen pipe union. Remove valve and manifold.
7. Remove main orifice
8. Reassemble in reverse order.

ORIFICE, BYPASS

1. Loosen flare nut and remove bypass orifice.
2. Reassemble in reverse order.

THERMOSTAT, HIGH LIMIT, OVEN CAVITY

1. Shut off power at main breaker.
2. Remove conveyor.
3. Remove control compartment covers.
4. Remove screws from bracket.
5. Remove the mounting nut from the threaded shaft.
6. Remove the capillary tube bulb from the wireholder in the oven heating chamber.
NOTE: Access to the capillary tube bulb is through the front door, after removing the conveyor and fingers.
7. Insert the new capillary tube bulb through the tube into the oven cavity and into the wire form holder
NOTE: The wire form must hold the bulb firmly. If it does not, compress the wire form slightly to increase the pressure.
8. Reassemble in reverse order.
9. Push the reset button. Test system for proper operation.

THERMOSTAT, HIGH LIMIT

1. Shut off power at main breaker.
2. Remove conveyor.
3. Remove control compartment covers.
4. Remove 2 screws from holding bracket located in upper rear of the control compartment.
5. Remove the 2 leads and remove thermostat.
NOTE: Push reset button
6. Insure that aluminum probe and teflon washer are in place (if applicable), then reassemble in reverse order.
7. Insure that thermostat is in firm contact with the aluminum probe (if applicable).

LAMP, PILOT BURNER

LENS, PILOT LAMP

1. Shut off power at main breaker.
2. Remove conveyor.
3. Remove front control compartment cover.
4. Remove terminals from pilot lamp.
5. Grasp body of the light assembly and slide to the side disengaging body from light lens.
6. Remove lens by pushing out from rear.
7. Reassemble in reverse order.

COUPLING, CONVEYOR DRIVE

FOR ALL 1100 MODELS

This coupling has a plastic or rubber sleeve connecting two metal drive ends. The metal drive end on the conveyor side is secured by a ball plunger screw. This is not a set screw and should never be overtightened.

PROCEDURE FOR ADJUSTING DRIVE COUPLING:

1. Place one metal end on conveyor shaft.
2. Install ball plunger and adjust so the spring loaded ball will drop into the dimple on the flat of the conveyor drive shaft. To test, apply pressure on metal end towards the conveyor. The ball detent should pop up out of the dimple and coupling end will slide back to conveyor frame.
3. Place other drive end on motor shaft,
4. Push conveyor frame to front side of oven conveyor opening.
5. Adjust the metal drive end on conveyor shaft so ball detent is in the dimple.
6. Lift conveyor drive side slightly and place sleeve on conveyor side metal drive end.
7. Adjust motor side coupling drive end so sleeve is now held in place between the drive ends and tighten set screw on motor side firmly.

To remove conveyor, simply grasp the coupling sleeve and pull towards conveyor. The sleeve and drive end will slide towards the conveyor and separate from the motor drive.

GEARMOTOR, D.C., CONVEYOR

1. Shut off power at main breaker.
 2. Remove conveyor.
 3. Remove control compartment covers.
 4. Remove metal drive end from the motor shaft.
 5. Remove electrical leads from gearmotor assembly and mark for proper reassembly.
 6. Remove 4 screws holding gearmotor to side wall of control compartment.
 7. To remove tach., optical encoder assembly, and coupling and encoder disc refer to the following instructions.
 8. Reassemble in reverse order using care to readjust motor properly to be in line with conveyor coupling.
- NOTE: If a new gearmotor is installed, the D.C. motor control board must be recalibrated.

COUPLING AND ENCODER DISC

1. Remove gearmotor assembly (See "GEARMOTOR")
2. Remove dust cover above motor.
3. Loosen both allen set screws (.050 inch allen wrench) located on coupling hub.
4. Remove 3 screws from tach. bracket, loosen the 4th.
5. Remove encoder assembly, see "OPTICAL ENCODER ASSEMBLY" in following procedure.
6. Push coupling down on motor shaft. Swivel tach. bracket aside and remove coupling.
7. To install, push coupling on to motor shaft. The encoder disc must be nearest motor.
8. Refasten tach. bracket in proper alignment.

1. Tighten the set screw on the tach. side first maintaining the .010 minimum dimension between the coupling hub and tach.
2. Pull the coupling apart (approximately 1/8", 3.2mm) and fasten the motor side set screw.
3. Install the optical encoder, refer to "OPTICAL ENCODER" in this section for adjustment.
NOTE: The thin, slotted encoder disc must be handled with care so not to bend it.
4. Recheck tightness on the set screws to be sure they are tight. If available, LOC TITE (the removable kind) should be used to secure set screws.

OPTICAL ENCODER ASSEMBLY

1. Remove gearmotor assembly (see "GEARMOTOR") Above.
2. If replacing with new assembly, cut wires to remove as new wires and plug are provided. If only removing for access to coupling, see step 3.
3. Remove pins from connector with pin extractor tool, P/N 369600.
4. Loosen dust cover screws and pull dust cover away from motor.
5. Remove 2 screws from optical encoder and remove encoder.
6. Reassemble in reverse order.
7. To adjust optical encoder:
 - a. Position the encoder assembly so it does not rub the coupler hub and is square with the encoder disc. The infrared light beam will be broken by slots in the encoder disc. The encoder disc should not touch the bottom or top of the optical encoder, if it does, readjust the coupling. The digital speed readout may be observed to check proper adjustment of the optical encoder assembly.

TACH. GENERATOR

1. Turn off power at main breaker.
2. Remove gearmotor assembly (see "GEARMOTOR")
3. Remove tach. cover plate and tach. leads. Mark wires for reassembly.
4. Remove 2 slotted screws from dust cover base and remove dust cover.
5. Loosen coupling set screw (.050 inch allen wrench).
6. Remove tach. bracket from motor. (4 screws)
7. Remove 4 screws from base of tach. and tach. is now free for removal.
8. Reassemble in reverse order. Maintain spacing of .010 minimum between tach.bracket and coupler hub.
NOTE: If a new tach. generator is installed, the D.C. motor control board MUST BEREALIBRATED. There is no repair procedure for the tach. If defective, replace.

D C MOTOR CONTROL BOARD

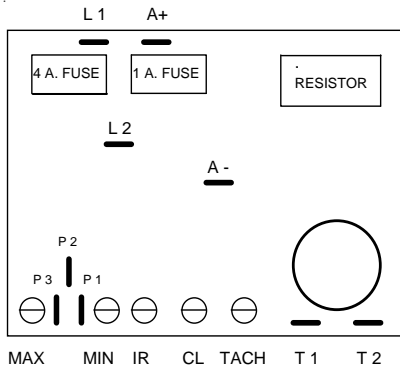

BOARD P/N 369155
STYLE 1

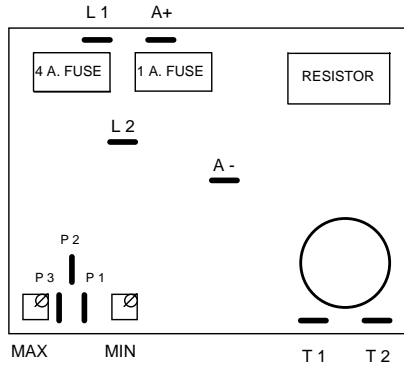

BOARD P/N 369155
STYLE 2

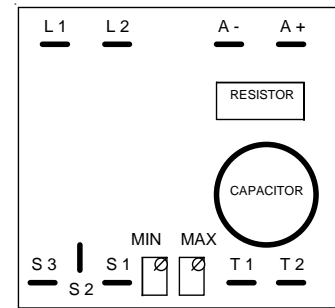

BOARD P/N 369155
STYLE 3

Three different styles of control boards have been used and all three are still usable.
All three were supplied under the same part number.

TO REPLACE THE CONTROL BOARD:

1. Turn off power at main breaker and remove front control compartment cover.
 2. Remove conveyor.
 3. Remove and mark all wires from board
 4. Remove control board bracket and board from unit, 3 screws.
 5. Remove control board from mounting bracket. Remove 4 screws, lockwashers, and nuts.
 6. Install new control board and bracket.
 7. Attach wires to their proper terminals, refer to the drawings for proper terminal identification.
 8. Perform calibration on the control board as specified using the calibration procedure for your style of board.
- NOTE: When a control board, motor, tach. generator, or speed adjustment potentiometer is replaced, the control board must be calibrated. When calibration of control board is complete, seal the adjustment pots. (See "Control Board Adjustment")

STYLE 1 CONTROL BOARD ADJUSTMENT

NOTE: A digital meter must be used for this adjustment.

1. Voltage at L1 and L2 terminals of the control board is to be 120 VAC \pm 10%.
2. Connect a digital volt meter to terminals A+ and A-, set meter on 200 VDC scale.
3. Turn speed control pot. (on oven control panel) to its maximum speed setting.
4. Turn "MAX", "MIN", and "IR" pots counter clockwise until they stop. (DO NOT turn CL pot.)
5. Adjust "TACH" pot. so the volt meter indicates 130 VDC \pm 0.5 volts.
6. Adjust "IR" pot. to read between 1.5 and 2 VDC above tach. reading. (Example: If tach. reading would be 130.3 then adjust IR to between 131.8 VDC and 132.3 VDC.)
7. Turn speed control pot. to its minimum speed setting.
8. Adjust "MIN" pot. so the voltmeter indicates between 6 and 10 VDC.
9. Turn speed control dial to obtain a reading of 22 VDC on your meter. Observe for approx. 30 seconds to see if stable within \pm 0.5 VDC. Repeat at 35 VDC.
10. Check speed of conveyor and adjust time/temp. display if necessary.
11. Seal pots with Glyptol or nail polish.

STYLE 2 AND STYLE 3 CONTROL BOARD ADJUSTMENT

NOTE: A digital meter must be used.

1. Voltage at L1 and L2 terminals of the control board is to be 120 VAC \pm 10%.
2. Connect a Digital voltmeter to terminal T1 and T2, set the meter on DC scale.
3. Turn speed control pot. (on oven control panel) to its maximum speed setting.

1. Adjust the "MAX" pot. so the voltmeter indicates 15.8 to 15.9 VDC.
 2. Turn the speed control pot. to its minimum speed setting.
 3. Adjust the "MIN" pot. so the volt meter indicates 0.7 to 0.9 VDC.
 4. Reset the speed control pot. to its maximum speed setting and check if voltage is still at 15.8 to 15.9 VDC. Readjust if necessary.
 5. Reset the speed control pot. to its minimum speed setting and check if voltage is still at 0.7 to 0.9 VDC. Readjust if necessary.
 6. If readjustment of either the "MAX" or "MIN" pot. was necessary, the opposite must always be checked until both "MIN" and "MAX" are in proper adjustment.
 7. Measure the speed of the conveyor and adjust the time/temp. display if necessary.
 8. Seal pots with Glyptol or nail polish.
- NOTE: Occasionally a new board (Style 2 and 3 only) is so far out of adjustment that you will be unable to adjust to the correct voltage. To correct, turn both the "MAX" and "MIN" pots 10 turns in either direction and then 5 turns in opposite direction. This will center the pots and allow them to be calibrated. If after this procedure, the board will not adjust, it is probably defective.

REVERSAL OF CONVEYOR BELT - D.C. Motor

All ovens leaving our plant are wired to operate conveyors from left to right. To reverse conveyor direction, use the following procedure.

1. Turn off power and remove conveyor.
2. Remove front control compartment cover.
3. Refer to control board drawing to identify terminal connections.
4. Reverse wires fastened to terminals A+ and A-.
5. Reverse wires fastened to terminals T1 and T2.

Both set of leads must be reversed or oven will run at maximum speed with no speed adjustment possible.

POTENTIOMETER, CONVEYOR SPEED CONTROL

1. Turn off power.
2. Remove conveyor.
3. Remove front control compartment cover.
4. Remove adjustment knob. Two allen set screws.
5. Remove exterior friction shaft retainer from pot shaft. Turn counter-clockwise to loosen.
6. Remove pot shaft from hole and disconnect leads from motor control board.
7. Assemble in reverse order.
8. If a new pot. is installed, the motor control board must be calibrated.

MINI BREAKER 0.2 AMP

1. Shut off power at main breaker.
2. Remove conveyor.
3. Remove control box covers.
4. Remove knurled mounting ring and disconnect wiring.
5. Reassemble in reverse order.
6. Push button to set.

BEARING, CONVEYOR

1. Remove conveyor from oven and place on a flat work surface.
2. Remove connecting links from conveyor belting. See Installation and Operating Instructions manual.,
3. Move drive shaft or idle shaft toward end of conveyor, and shaft with bearings will now slip out of holding bracket.

Replace bearing and reassemble.

TRANSFORMER, TIME/TEMP. DISPLAY

1. Shut off power at the main breaker.
2. Remove conveyor.
3. Remove front control compartment cover.
4. Remove transformer wires and mark for replacement.
5. Remove 2 mounting screws and replace transformer.
6. Reassemble in reverse order.

TIME/TEMP. DISPLAY

1. Shut off power at main breaker.
2. Remove conveyor.
3. Remove front control box cover.
4. Mark all leads for proper reinstallation and then remove wires from all terminals at rear of the display.
5. Remove 2 screws from top of Time/Temp. case holding the case to the front panel.
NOTE: On some of the more recent Model 1100 units, the time/temp. display may now be removed. If it is not free, continue.
6. Remove 3 screws from the front panel, lift up the front panel and remove 2 screws from the bottom of the display case. Display should now be free to remove.
7. Replace in reverse order.

NOTE: BEFORE TURNING ON POWER, SET THE DIP SWITCHES TO THE PROPER SETTING.

DIP SWITCH SETTING CHART:

To identify the module, measure the width of the case.

Type I is 5 1/8 inches wide x 4 1/2 inches deep

Type II is 5 5/8 inches wide x 4 1/2 inches deep

Type I & II have a 6 position dip switch module

Type III has a 10 position dip switch module

Type IV is 5 5/8 inches wide x 3 1/4 inches deep

Type IV has adjustment pots. in the center of the board

*THESE SWITCHES ARE FOR HERTZ SETTINGS - OFF=60HZ or ON=50HZ

**THESE SWITCHES ARE FOR TEMPERATURE SETTINGS - OFF=°F or ON=°

MODEL 1100 SERIES OVENS

	1	2	3	4	5	6	7	8	9	10
Type 1	Off	*Off	On	On	** Off	Off				
Type II	Off	*	**	On	Off	On				
Type III (Baldor)	Off	*	**	Off	On	On	On	Off	On	On
Type III (Stepper)	Off	*	**	On	On	Off	Off	On	Off	On
Type IV (Baldor)	Off	Off	**	Off	On	On	On	Off	On	On
Type IV (Stepper)	Off	Off	**	On	On	Off	Off	On	Off	On

Stepper Motor - Conveyor Speed 23 Seconds to 30 Minutes

Type III	Off	* Off	** Off	On	On	Off	On	Off	On	On
Type IV	Off	Off	** Off	On	On	Off	On	Off	On	On

TIME TEMP DISPLAY FOR D.C. DRIVE

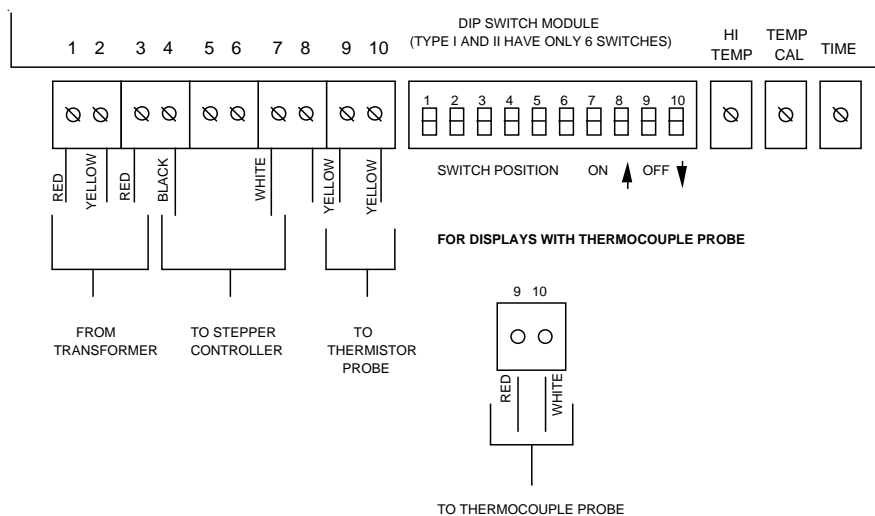

TEMPERATURE CALIBRATION

1. Set dip switches per chart on Page D15.
2. Place a thermocouple from your test pyrometer through a hole in the center of the top finger. Tip of pyrometer must not touch metal!
3. Set oven at 500°F (260°C) and allow to preheat for 30 minutes.
4. Adjust temperature calibration pot. so display agrees with your test meter.
5. Seal pot. with Glyptol or nail polish.
6. If display will not adjust properly, check your pyrometer for accuracy and if necessary, refer to troubleshooting section.

If temperature is still inaccurate after above calibration and troubleshooting, use the following to check the High Temp. Pot. normally the High Temp. Pot. does not require adjustment. Occasionally the pot. is accidentally moved or needs adjustment. Refer to the following drawing showing proper adjustment of the High Temp. Pot.

FOR DISPLAYS WITH THERMISTOR PROBE ONLY

BOTTOM OF TIME TEMP DISPLAY

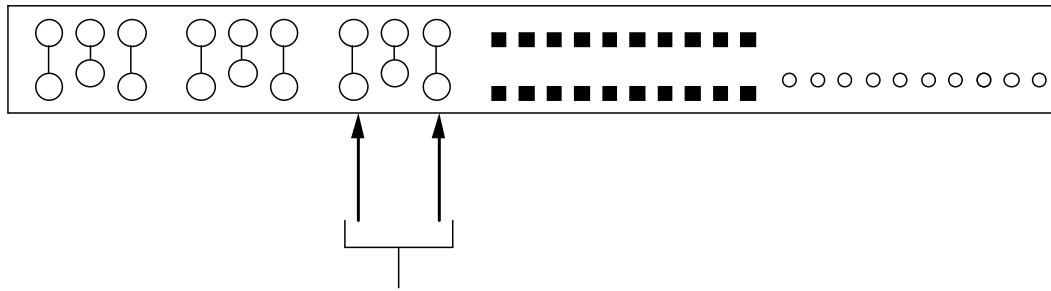

test leads here
 reading should be $26 \pm .5$ ohms if not, adjust.
 pot. range 0-34 ohms

TIME CALIBRATION

1. Be sure dip switch settings are proper.
2. Turn power on.
3. Turn conveyor on.
4. Place an object on the conveyor belt and time with a stopwatch, the elapsed time for the object to travel through the oven (leading edge in to leading edge out).
5. Push in and hold the set button. (Discontinued on newer models)
6. Adjust time pot. (rear of display) so display agrees with your stop watch time.
7. Seal pot. with Glyptol or nail polish.

THERMISTOR PROBE REPLACEMENT

1. Shut off power at the main breaker.
 2. Remove conveyor and fingers from oven.
 3. Remove control compartment covers.
 4. Disconnect the 2 yellow thermistor leads from terminals 9 and 10 on the rear of the time/temp. display.
 5. Remove the sensing bulb of the thermistor probe from its wire form holder located at right inside rear of the oven.
 6. Install in reverse order.
- NOTE: Be sure that the spring holder is holding the sensor bulb firmly. If the sensor is not held firmly, compress the wire form slightly to increase pressure.

To test the thermistor probe, refer to the following chart and instructions:

	OVEN		TEMPERATURE					
	300°F	325°F	350°F	400°F	425°F	450°F	500°F	550°F
OHMS	182	138	102	62	48	38	24	16

1. Place test pyrometer thermocouple and preheat oven as specified under temperature calibration on Page D15.
2. Disconnect the thermistor probe from terminals 9 and 10 and measure the resistance across the 2 yellow leads
3. Refer to the above chart to determine if probe is producing the proper resistance.
EXAMPLE: The probe resistance at 500°F(260°C) should be 24 ohms.

SWITCH, DISPLAY, SET

- 1 Shut off power at main breaker.

1. Remove conveyor.
2. Remove front control compartment cover.
3. Disconnect wires from time/temp. display terminals 5 and 6.
4. Pull off black operating knob and remove hex mounting nut.
5. Reassemble in reverse order.

PROCEDURE FOR USE OF TIME/TEMP SIMULATOR

NOTE: For displays with Thermocouple, simulator will not work.

This is a test device used to check the Time/Temp. Display

Procedure for use:

1. Check incoming power to display at following terminals.
 - a) Terminal 1 to 3 should have approximately 12.5 to 15 VAC.
 - b) Terminal 2 to 1 should be 1/2 of the reading from 1 to 3.
 - c) Terminal 2 to 3 should also be 1/2 of the reading from 1 to 3.
2. Identify Display type:
 - a) Type 1 has 6 dip switches and display case is 5 1/8" wide (12.8cm).
 - b) Type 2 has 6 dip switches and display case is 5 5/8" wide (14 cm).
 - c) Type 3 has 10 dip switches.
3. Set Dip Switches as follows:

	1	2	3	4	5	6	7	8	9	10
TYPE 1	OFF	OFF	OFF	ON	OFF	OFF				
TYPE 2	OFF	OFF	OFF	OFF	OFF	OFF				
TYPE 3	OFF	OFF	OFF	OFF	OFF	OFF	OFF	ON	OFF	ON

1. **WITH POWER OFF:** Remove all leads from T/T display except power input on 1,2 and 3. Install simulator to terminals 4, 7, 9, 10.

NOTE: When on 50 Hz power dip switch number 2 must be on.

2. **WITH POWER ON:** Turn time and temperature adjustment pot. fully counter clockwise. Display should read (wait 15 seconds after turning):

	SPEED	TEMPERATURE
TYPE 1	9:30 ± 10 SEC.	475° ± 10°F
TYPE 2	9:20 ± 10 SEC.	HHH
TYPE 3	9:35 ± 10 SEC.	635° ± 10°F

- 1 Turn time and temperature pot. fully clockwise.

Display should read (wait 15 seconds after turning):

	SPEED	TEMPERATURE
TYPE 1	10:20 ± 10 SEC.	615° ± 10°F
TYPE 2	10:10 ± 10 SEC.	475° ± 10°F
TYPE 3	10:20 ± 10 SEC.	475° ± 10°F

- 1 For performance test, turn time pot. to 10:00 and temp. adjustment pot. to 540° ± 10°F.

1. Time reading on display of 10:00 should not fluctuate more than ± 5 seconds.
2. Temperature on display reading should not fluctuate.

SWITCH, ON/OFF

1. Shut off power at main breaker.
2. Remove conveyor.
3. Remove front control compartment cover.
4. Remove wires from switch and mark for reassembly.
5. Depress spring clips on the side of switch and push out.
6. Reinstall in reverse order.

TRANSFORMER, STEP DOWN/120 VAC

1. Shut off power at main breaker.
2. Remove Conveyor.
3. Remove control compartment covers.
4. Remove wires from transformer and mark for reassembly.
5. Remove 4 mounting screws from transformer base and replace.
6. Reassemble in reverse order.

FUSEHOLDER

1. Shut off power at main breaker.
2. Remove conveyor.
3. Remove control compartment covers.
4. Remove wires and mark for reassembly.
5. Remove fuseholder.
6. Reassemble in reverse order.

POWER CORD

1. Shut off power at main breaker.
2. Remove conveyor.
3. Remove control compartment covers.
4. Unfasten and mark for reassembly power cord wires.
5. Remove locknut from strain relief and pull cord from oven.
6. Reassemble in reverse order.

STEPPER CONTROL-REPLACEMENT-ADJUSTMENT

Removal and Installation

1. Remove conveyor.
2. Remove control box cover - front.
3. Remove three (3) screws from control assembly.
4. Disconnect wiring (push on connectors) from control board.
NOTE: Proper location of connectors for reinstallation.
5. Reassemble in reverse order and check system operation.
6. Recalibrate conveyor control board.

WARNING: THIS CONTROL MUST NOT BE OPERATED WITH HEAT SINK DISCONNECTED OR BURNOUT WILL OCCUR IN SECONDS.

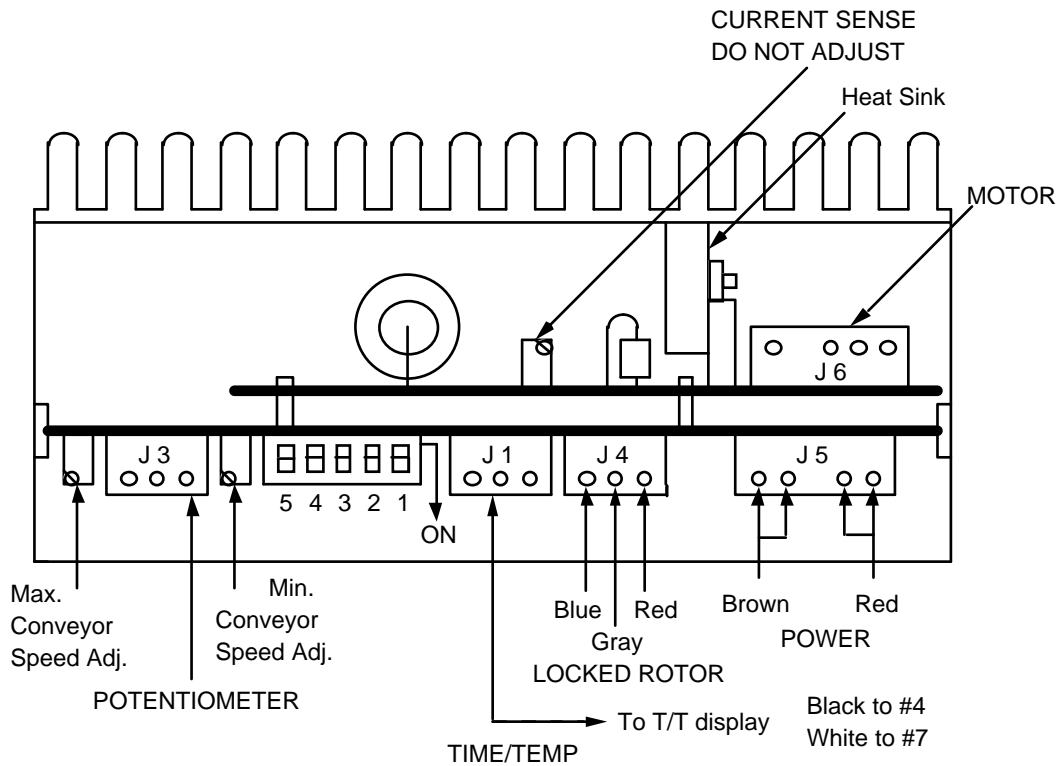

1. With power off, the five (5) dip switches located on the conveyor control (see drawing above) should be set as below.

DIP SWITCHES FOR 50 SEC. TO 30 MIN. TIMES

CONTROL SWITCH POSITION	1	2	3	4	5
	OFF	OFF	ON	OFF	OFF

DIP SWITCHES FOR 23 SEC. TO 30 MIN. TIMES

CONTROL SWITCH POSITION	1	2	3	4	5
	OFF	ON	OFF	OFF	OFF

2. With power off, the ten (10) dip switches located on rear of Time/Temp Display (see drawing on page D15) should be set as below.

NOTE: For time/temp displays using a thermister (2 yellow wires on Terminals 9 & 10), set the dip switches as follows:

FOR 50 SEC TO 30 MIN CONVEYOR TIMES

DISPLAY SWITCH POSITION	1	2	3	4	5	6	7	8	9	10
	OFF	*	*	ON	ON	OFF	OFF	ON	OFF	ON

For time/temp displays using a thermocouple (red wire on #9 and white wire on # 10), set the dip switches as follows:

* Off for °F
* On for °C

DISPLAY	1	2	3	4	5	6	7	8	9	10
SWITCH POSITION	OFF	OFF	*	ON	OFF	OFF	ON	ON	OFF	ON

FOR 23 SEC. TO 30 MIN. CONVEYOR TIMES

NOTE: For time/temp displays using a thermistor (2 yellow wires on terminals 9 & 10), set the dip switches as follows:

DISPLAY	1	2	3	4	5	6	7	8	9	10
SWITCH POSITION	OFF	*	*	ON	ON	OFF	ON	OFF	ON	ON

For time/temp displays using a thermocouple (red wire on #9 and white wire on # 10), set the dip switches as follows:

* Off for °F
* On for °C

DISPLAY	1	2	3	4	5	6	7	8	9	10
SWITCH POSITION	OFF	OFF	*	ON	OFF	OFF	ON	ON	OFF	ON

1. With conveyor running, set conveyor speed control so Time/Temp. Display indicates 5:00 minutes. Place a pan on the conveyor, measure (STOPWATCH) the time (SPEED OF PAN) of the leading edge in to leading edge out of oven. Turn the time adjustment pot. on the rear of the Time/Temp. Display so display agrees with time measured by the stop watch.
2. Turn conveyor speed control fully counterclockwise and adjust the stepper control maximum speed pot(refer to drawing Pg. D-19) so the display indicates 50 seconds.
3. Turn conveyor speed control fully clockwise and adjust the stepper control minimum speed pot so the display indicates 30 minutes.
NOTE: Repeat 4 and 5 to be sure settings are accurate.
4. Turn power off and set #1 dip switch to its (ON/OFF) other position and verify that the conveyor reverses direction when power is applied. Set conveyor travel direction as customer requests.
CAUTION: ALWAYS REMOVE POWER BEFORE CHANGING CONVEYOR DIRECTION.

TO REVERSE CONVEYOR DIRECTION ON STEPPER DRIVE SYSTEM

1. Shut off power at main breaker.
2. Remove conveyor.
3. Remove front control box cover.
4. Change position of dip switch #1 on stepper control board as described on Page D20
5. Reassemble in reverse order.

TRANSFORMER - STEPPER MOTOR CONTROL

1. Shut off power at main breaker.
2. Remove conveyor.
3. Remove front cover.
4. Disconnect transformer wire harness.
5. Remove two (2) mounting screws.
6. Reassemble in reverse order.

HALL EFFECT SENSOR - REPLACEMENT

Remove two (2) mounting screws and remove sensor from conveyor motor. Reinstall in reverse order.

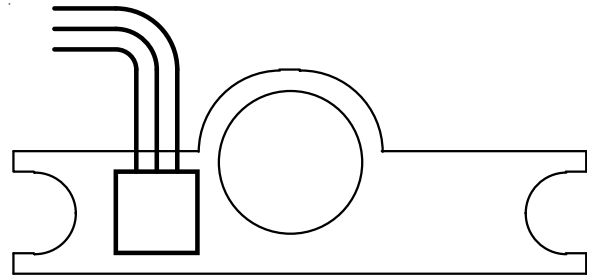

THE FOLLOWING COMPONENTS ARE USED FOR MODEL 1152-1158 ONLY

GAS VALVE, MULTI BLOCK FOR MODELS 1152 Through 1158

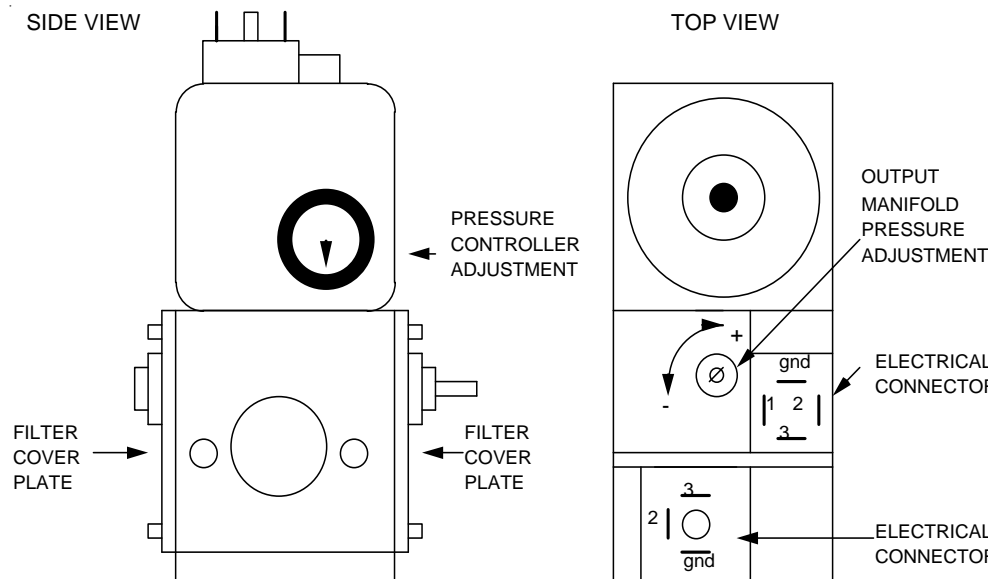

REMOVAL PROCEDURE:

1. Turn off power at the circuit breaker panel.
2. Turn off gas in main line before the flexible hose.
3. Remove control compartment covers.
4. Remove 4 screws from bulkhead plate on back of oven at gas pipe.
5. Remove gas pipe and bulkhead plate from gas valve.
6. Remove the 2 electrical plugs from the gas valve.
7. Unscrew the aluminum tubing connector from the gas valve.
8. Remove the cross brace from the top of the control cabinet.
9. Unscrew the pipe union and remove the gas valve.
10. Reassemble in reverse order and check for gas leaks.

ADJUSTMENT PROCEDURE - Refer to drawing above:

1. Remove the plastic cover (2 screws) exposing the pressure controller adjustment dial and adjust as follows:

	NATURAL GAS	LP GAS	CITY/TOWN GAS
PRESSURE CONTROLLER DIAL SETTINGS	8.8	23	4.5

2. Install a test manometer in the gas line between the gas valve and burner orifice. The test plug is located in the gas line just below and on the burner side of the solenoid valve. The output manifold pressure adjustment is made with a slotted screw located under a swivel cover marked "DRUCKREGLER". The following chart is provided for manifold pressure adjustment, However, always, refer to the Oven Identification Plate to be sure the proper type of gas and pressure for that specific oven are being used.

TYPE OF GAS	INCHES of WATER COLUMN	CENTIMETERS of WATER COLUMN	kPa	Mbar
NATURAL GAS	3.5" WC	8.9 cm WC	.87kPa	8.70Mbar
L.P. GAS	10"WC	25.4 cm WC	2.48kPa	24.8Mbar
CITY/TOWN GAS	1.4"WC	3.56 cm WC	.35kPa	3.5Mbar

AIR PRESSURE SWITCH, BURNER OR OVEN CAVITY

TO REPLACE AIR SWITCH:

1. Shut off power at main breaker.
2. Remove conveyor.
3. Remove rear control compartment cover.
4. Remove cover of air switch exposing adjustment screw.
5. Disconnect and mark wires for proper reassembly.
6. Remove air tube and remove switch from hanger.
7. Reinstall in reverse order, making sure wires are properly attached and air tube is properly attached, unblocked and aligned properly to avoid crimping.

TO CALIBRATE AIR SWITCH:

1. If switch will not activate when blower pressure is supplied, turn adjustment screw counter clockwise (-).
2. If switch will not deactivate when blower pressure is eliminated, turn adjustment clockwise (+).

SPARK GENERATOR

1. Turn off power.
2. Remove conveyor.
3. Remove control compartment covers.
4. Disconnect 2 power leads to ignition control. (Located in bottom front of rear control compartment).
5. Disconnect high voltage cable.
6. Remove 2 screws and lift out generator.
7. Replace in reverse order.

IGNITER SENSOR PROBE

1. See Page D8 to remove "hot surface ignitor".
2. Unfasten screws and remove probe.
3. Disconnect wires and replace probe in reverse order.

IGNITION CONTROL

1. Shut off power at main breaker.
2. Remove control compartment covers.
3. For Honeywell Ignition Control, loosen 2 screws and remove control from base. For Landis & Gyr Ignition Control, depress 2 clips and remove control from base.
4. If replacing the control and base, remove the control first and then 2 screws holding the base. Mark wires prior to removal.
5. Reassemble in reverse order. Be sure base is correctly mounted or reset will not align with cover hole.

MOTOR, BURNER BLOWER

1. Shut off power at main breaker.
2. Remove conveyor.
3. Remove control compartment covers.
4. Remove conveyor gear motor.
5. Loosen 4 burner nuts holding burner flange to oven wall.
6. Unplug burner blower motor. This plug has built in locking clips on 2 sides of the plug. Push in to release.
7. Loosen 3 screws holding the blower air horn to burner.
8. Remove top control compartment brace.
9. Spring back side of control box out slightly, push burner to side, and you should now be able to pull the right side of the motor to the front, which should free the air horn from the burner. In some extreme cases the cooling fan may have to be removed.
10. Assemble in reverse order.

BURNER ALARM - REPLACEMENT

1. Remove control compartment covers.
2. Remove two (2) wires from alarm, note wire numbers and location.
3. Remove retainer cover from alarm and remove assembly from mounting bracket.
4. Reassemble in reverse order and check.

GENERAL -1100 SERIES

LETTER	P/N	DESCRIPTION
A	369390	4" Caster w/ Mounting Plate
B	369502	Bottom Finger Cover
C		Columnating Plate, See Install, Operations Manual
D		Bottom Finger Housing
	369505	S/N 2018676 & Below
	370010	S/N 2018677 & Above
E	369504	Top Finger Housing
F		Columnating Plate, See Install, Operations Manual
G	369503	Top Finger Cover
H	369669	Front Panel Label (with set button)
	369907	Front Panel Label (without set button)
J	369511	Oven Top
K	369659	Conveyor Hole Cover
L	369228	Conveyor Hole Cover
M	369227	Catch Spring
N	369588	Ball Stud
	369693	Spacer for Ball Stud
O	371066	Baffle, Inlet, Outlet
P	369211	Thumb Screw
Q	370118	Cross Support
R	369919	Stand Side
S	369231	4" Caster w/ Threaded Stem
T	369232	Adjustable Leg

GENERAL 1100 SERIES BLOW UP

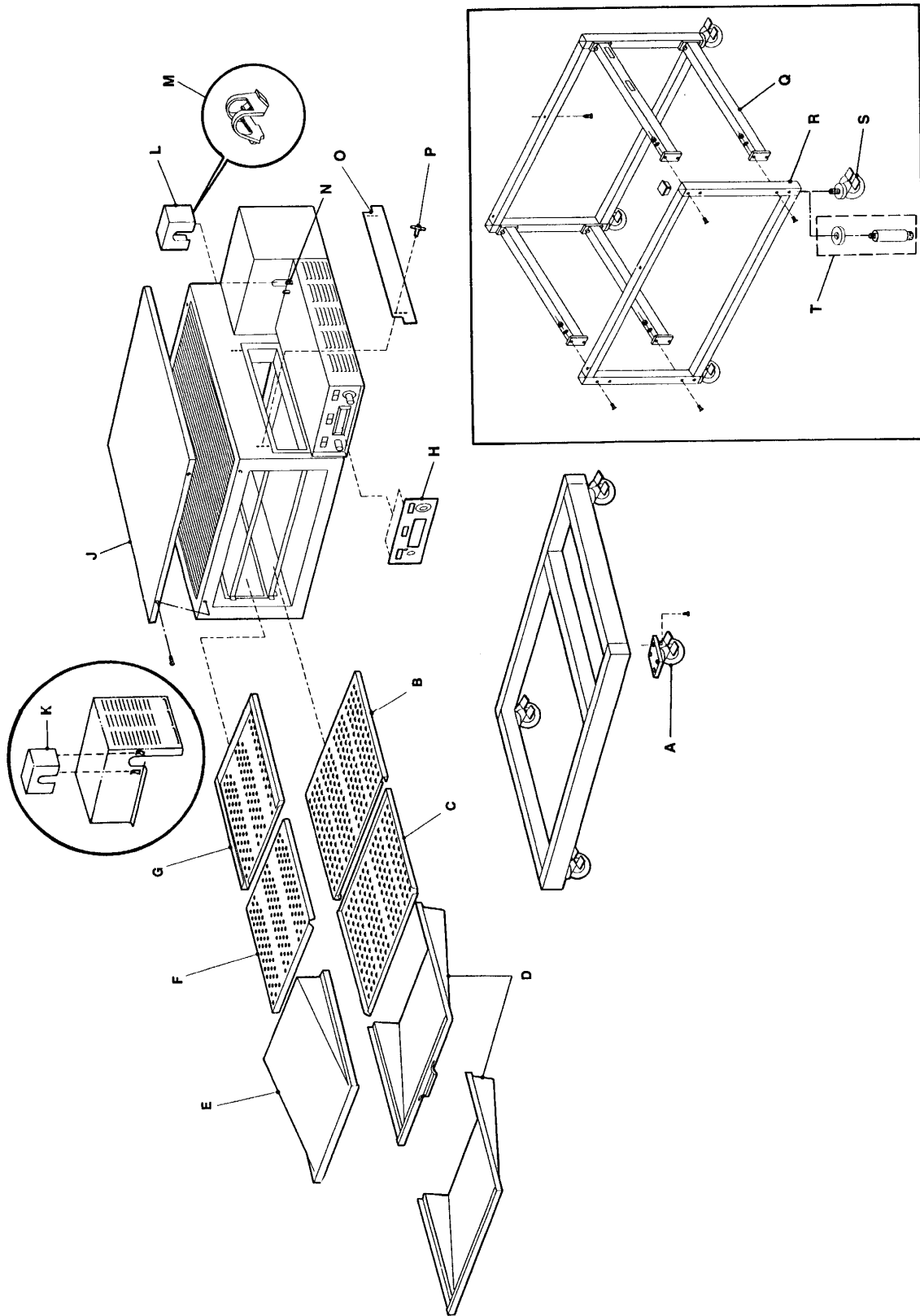

CONTROL COMPARTMENT-FRONT MODELS 1100 Thru 1106, 1130 Thru
1136,1150,1151,1160 Thru1163

LETTER	P/N	DESCRIPTION
A	369173	Transformer,12.6 VAC
B	369536	Cordset,Cooling Fan
C	369124	Cooling Fan
D	350224	Lens, Yellow
	350225	Lens, Red
E	369522	Knob & Dial, Thermostat
F	369669	Front Panel Label w/Set Button Except 1150
	369907	Front Panel Label w/o Set Button Except 1150
G	369248	Knob, Speed Control
H	369247	Shaft Lock
I	370046	Button Only
J	369260	Switch, On/Off
K	369167	Switch, Display, Set
L	369680	Front Cover Assembly
M	369152	Potentiometer, Conveyor, All models prior to S/N 2011383 and Models 1160 thru 1163 prior to S/N 2011978
	369391	Potentiometer, Conveyor S/N 2011383 & Up. 1160-1163 S/N 2011978 & Up
N	369172	Display, Time/Temp
O	369128	Lamp, Pilot
P	369520	Potentiometer, Temperature
Q	369728	Temperature Control
R	369155	Conveyor Control, All Models prior to S/N 2011383 Except Model 1160-1163 prior to S/N 2011978
S	369240	High Hat (used with 369155)
T	369509	Relay Cooling Fan, Not Used On 1100-1106
U	369193	Thermistor Probe, Yellow Leads
V	369131	Thermocouple Probe, 1 Red & 1 White Lead
W	369025	Air Pressure Switch
X	369189	Terminal Block
Y	369508	Time Delay , 20 Minute Not Used On Models 1100-1106
Z	369507	Thermostat, Cooling Fan Not Used On Models 1100-1106
AA	369640	Stepper Control,Models 1130 thru 1136, 1150,1151 S/N 2011383 and Up. Models 1160thru 1163 S/N 2011978 and Up
BB	369685	Drain Assembly
CC	369605	Transformer, Stepper Controller

**CONTROL COMPARTMENT-FRONT BLOW UP
MODEL 1100-1106, 1130-1136,1150,1151,1160-1163**

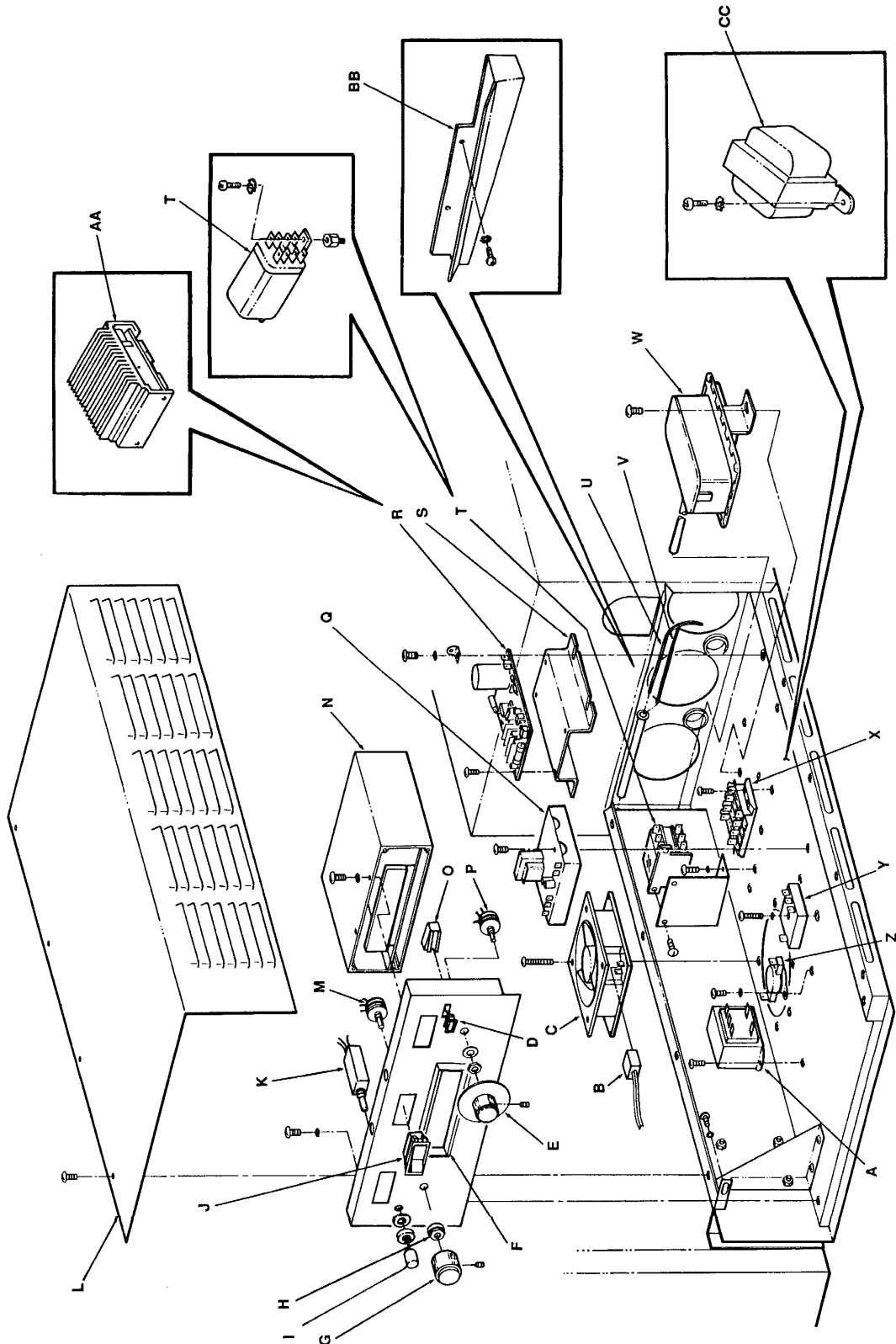

CONTROL COMPARTMENT - FRONT**MODELS 1152 THRU 1158**

LETTER	P/N	DESCRIPTION
A	369569	Cooling Fan
B	369507	Thermostat, Cooling Fan
C	369536	Cord Set, Cooling Fan
D	369124	Cooling Fan
E	369173	Transformer, 12.6 VAC
F	350224	Lens, Yellow
G	369522	Knob and Dial, Thermostat
H	369907	Front Panel Label All Models Except 1152-1153
	370142	Front Panel Label Model 1152-1153
I	369248	Knob, Speed Control
J	369247	Shaft Lock
K	370046	Button Only
L	369260	Switch, On/ Off
M	369680	Front Cover Assembly
N	*369167	Switch, Display Set
O	*369152	Potentiometer, Conveyor
	**369391	Potentiometer, Conveyor
P	369572	Lamp, Pilot
Q	369520	Potentiometer, Temperature
R	369172	Display, Time/Temp.
S	369508	Time Delay, 20 Minute
T	354258	Transformer, Step Down 120 VAC
U	369523	Relay
V	369728	Temperature Control
W	*369155	Control, Conveyor
X	369189	Terminal Block
Y	369523	Relay
Z	**369640	Stepper Control
AA	**369605	Transformer, Stepper Control
BB	369685	Drain Assembly
CC	369193	Thermistor Probe, 2 Yellow Leads
DD	369131	Thermocouple, 1 Red, 1 White Lead

* Used on S/N 2000200 to S/N 2011821

** Used on S/N 2011821 and Above

CONTROL COMPARTMENT – FRONT 1152-1158 BLOW UP

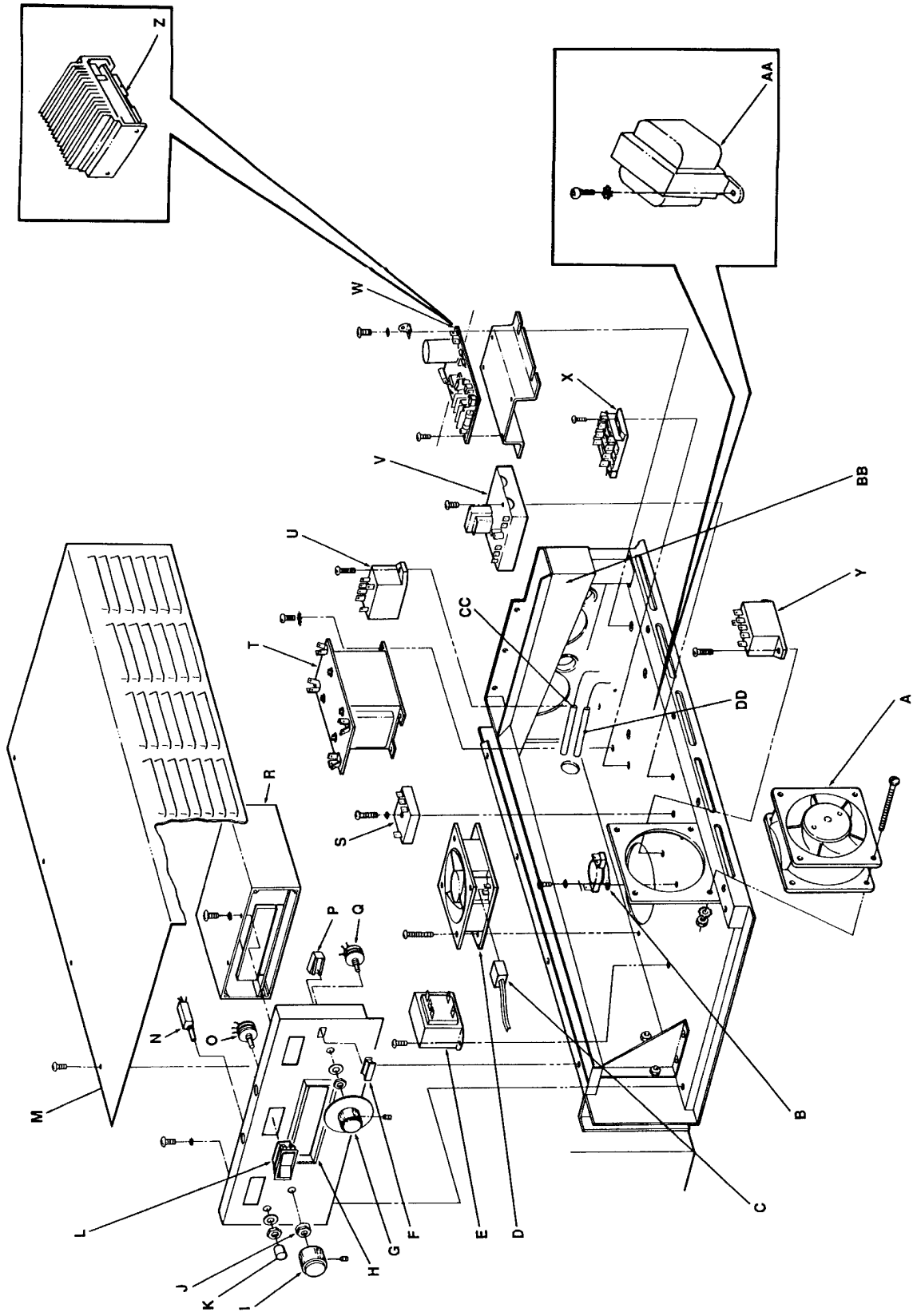

CONTROL COMPARTMENT – REAR
MODELS 1100-1106 MODELS 1130-1136,1150,1151 S/N 2011383 AND BELOW
MODELS 1160-1163 S/N 2011978 AND BELOW

LETTER	P/N	DESCRIPTION
A	369628	Set Screw
B	369190	Drive Coupling, Complete
C	369512	Rubber Sleeve
D	369269	'Ball Plunger
E		Gear Motor Assembly. (Refer to Page 116 for Exploded View)
F	369137	Circuit Breaker, 0.2 Amp
G	369192	Capacitor, 7.5 MFD
H	369200	Relay
I	369185	Terminal Block
		For 1 Phase Models (3 Required)
	369187	For 3 Phase Models (4 Required)
J	369186	Terminal Block End
		For 1 Phase Models
	369188	For 3 Phase Models
K	369120	Contactors
		For 1 Phase Models (2 Pole)
	369178	For 3 Phase Models (3 Pole)
L	354258	Transformer, Control
	354257	Transformer, Control Model 1151 Only
M	369506	Thermostat, High Limit
		For Models 1130,1131,1132,1133,1134,1135,1136, 1151,1160,1161,1162,1163
	369127	For Models 1100,1101,1102,1103,1104,1105,1106
N	369832	Back Cover
O	369583	Thermostat High-Limit For Model 1150
P	369772	Terminal Block
Q	370062	Electrical Box
R	370063	Cover
S	Fuses	See Chart On Next Page
T	Fuse Holders	See Chart On Next Page
U	369007	Thermostat, Cool Down For Models 1100, 1101, 1102, 1103, 1104, 1105, 1106

CONTROL COMPARTMENT – REAR BLOW UP
MODELS 1100-1106
MODELS 1130-1136,1150,1151 S/N 2011383 AND BELOW
MODELS 1160-1163 S/N 2011978 AND BELOW

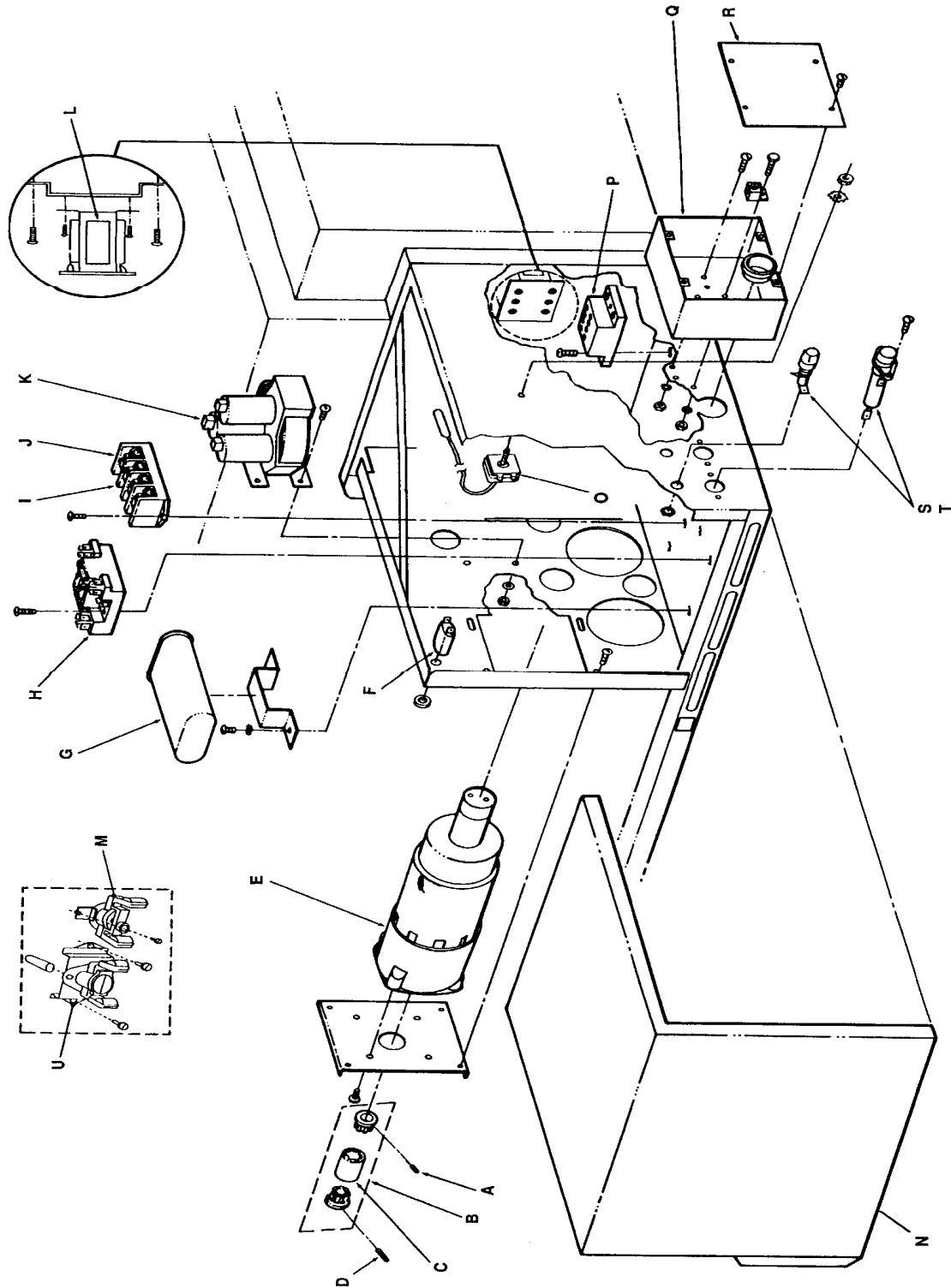

CONTROL COMPARTMENT – REAR
MODEL 1130-1136,1150,1151 S/N 2011383 AND ABOVE MODEL 1160-1163 S/N 2011978

LETTER	P/N	DESCRIPTION
A	369186	Terminal Block End For 1 Phase Models
	369188	For 3 Phase Models
B	369185	Terminal Block
	369187	1 Phase Models (3 Required)
	369120	3 Phase Models (4 Required)
C	369178	Contactors 1 Phase (2 Pole)
		3 Phase (3 Pole)
D	354258	Transformer, For Models 1134,1135,1136,1150
	354257	Transformer, For Model 1151 Only
E	369124	Cooling Fan
F	369331	Finger Guard
G	370062	Electrical Box
H	370063	Cover
I	Fuses	See Chart Below
J	Fuse Holders	See Chart Below
K	369200	Relay
L	369603	Conveyor Motor Assy. See Page 116 for Breakdown
M	369268	Set Screw
N	369664	Sleeve only, Conveyor Drive Coupling
O	369269	Ball Plunger
P	369611	Coupling, Conveyor Drive, Complete
Q	357067	Thermostat, Hi-Limit, All Models except 1150
	369583	Thermostat, Hi-Limit, Model 1150 only
R	369192	Capacitor, 7.5 MFD
S	353014	Ground Lug
T	369682	Back Cover Assembly

MODELS	S. FUSEHOLDERS					T. FUSEHOLDERS			
	1 AMP	1 AMP	3 AMP	10 AMP	10 AMP				
	369195	369335	369013	369166	369014	369304	369012	369129	357107
1100			2	2		2	2		
1101			2	2		2	2		
1102			2	2		2	2		
1103			2	2		2	2		
1104	1		2	1		1	2	1	
1105	1		2	1		1	2	1	
1106	1		2	1		1	2	1	
1130			2	2		2	2		
1131			2	2		2	2		
1132			2	2		2	2		
1133			2	2		2	2		
1134 BELOW S/N 2003879	1		2	1		1	2	1	
1134 ABOVE S/N 2003880		1	2		1				4
1135 BELOW S/N 2003879	1		2	1		1	2	1	
1135 ABOVE S/N 2003880		1	2		1				4
1136 BELOW S/N 2003879	1		2	1		1	2	1	
1136 ABOVE S/N 2003880		1	2		1				4
1150 BELOW S/N 2003879	1		2	1		1	2	1	
1150 ABOVE S/N 2003880		1	2		1				4
1151 BELOW S/N 2003879	2			2		2		2	
1151 ABOVE S/N 2003880		2			2				4
1160			2	2		2	2		
1161			2	2		2	2		
1162			2	2		2	2		
1163			2	2		2	2		

**CONTROL COMPARTMENT – REAR BLOW UP
 MODELS 1130-1136,1150,1151 S/N 2011383 AND ABOVE
 MODELS 1160-1163 S/N 2011978 AND ABOVE**

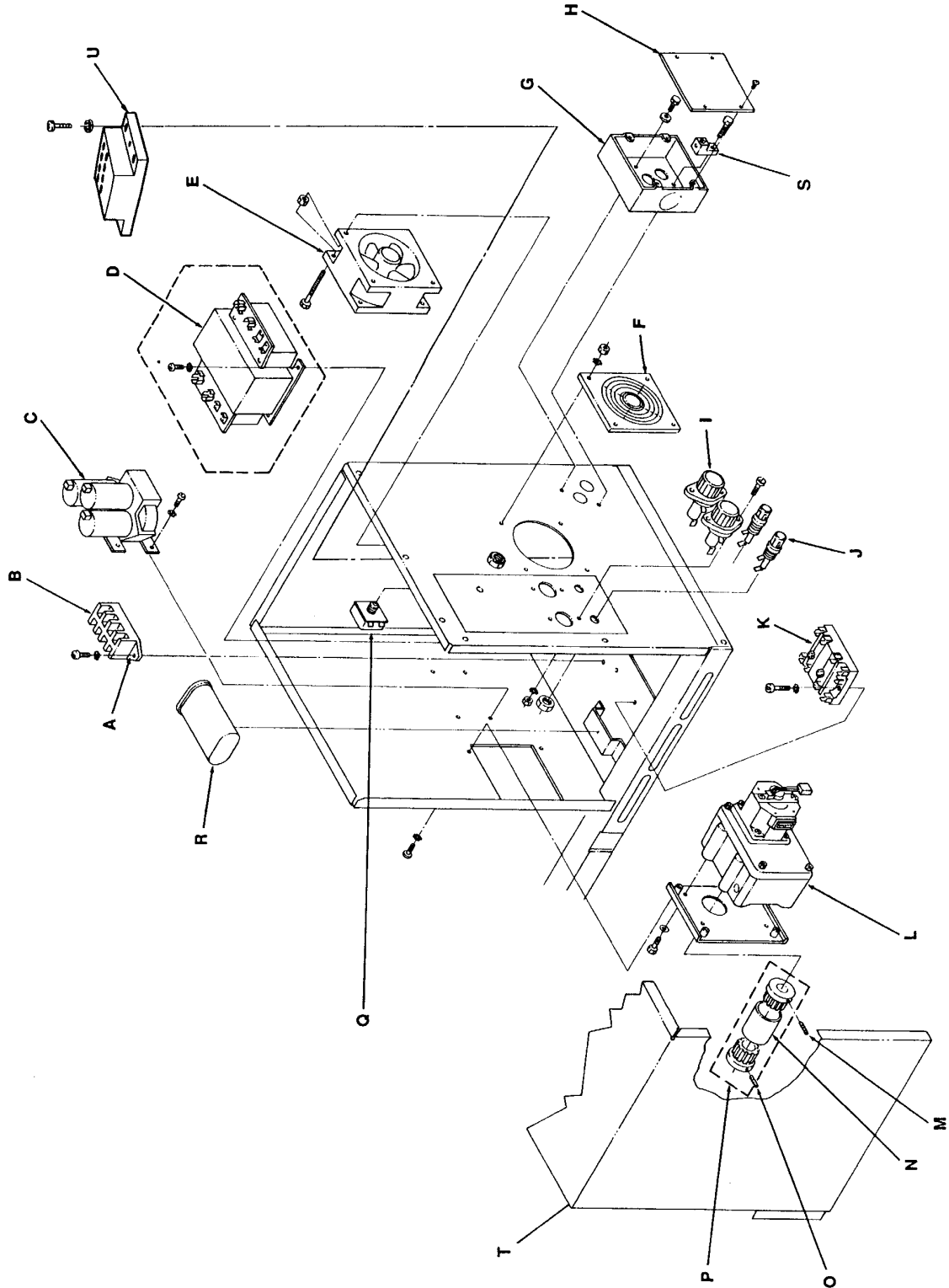

CONTROL COMPARTMENT – REAR
MODELS 1152, 1153, 1154, 1155, 1157, 1158 S/N 2011821 AND BELOW

LETTER	P/N	DESCRIPTION
A	369573	Control, Burner Ignition
B	369574	Spark Generator
C	369192	Capacitor, 7.5 MFD, Main Fan Motor
D		Gear Motor Assembly, See page 116 for Breakdown
E	370036	Main Orifice – For Models 1152,1154,1157
	369524	Main Orifice – For Models 1153,1155,1158
F	369575	Air Switch
G	369386	Support, Chain
H	369576	Flareless Tube Fitting
I		Bypass Tube Assembly
	369561	For Models 1152,1154,1157
	369404	For Model 1153
	369405	For Model 1155
	369562	For Model 1158
J	369689	Plug, Pressure Test
K	369398	Solenoid Valve
L	369656	High Voltage Lead, Spark Igniter
M	369657	Flame Sensor Lead
N	369654	Venturi Tube, Natural
	369939	Venturi Tube, L.P.
O	369590	Igniter Sensor Probe
P	370031	Bypass Orifice – For Models 1152,1154,1157
	369557	Bypass Orifice – For Models 1153,1155,1158
Q	369571	Connector, 4 Pole
R	369570	Connector, 3 Pole
S	369580	Gas Valve, Multi Block
T	369578	Hose
U	369917	Connector ¼" Tube to 1/8" Pipe Thread
V	369401	Air Shutter Assembly
W	369589	Burner Blowers
X	369533	High Limit, Control Compartment
Y	369579	Solid State Alarm
Z	369331	Finger Guard
AA	369335	Fuse, 1 Amp
	369013	Fuse, 3 Amp
	369014	Fuse, 10 Amp
BB	357107	Fuse Holder
CC	369583	Thermostat, Oven Cavity, High Limit
		For Models 1152,1153
	357067	For Models 1154,1155,1157,1158
DD	369137	Circuit Breaker, 0.2 Amp
EE	369124	Cooling Fan
	369535	Cooling Fan Cordset
FF	369512	Sleeve Only, Conveyor Drive Coupling
GG	369268	Set Screw
HH	369269	Ball Plunger
JJ	369376	Terminal Block 3 Pole
KK	370148	Back Cover Assembly
LL	369190	Conveyor Drive Coupling

**CONTROL COMPARTMENT – REAR BLOW UP
 MODELS 1152,1153,1154,1155,1157,1158 S/N 2011821 AND BELOW**

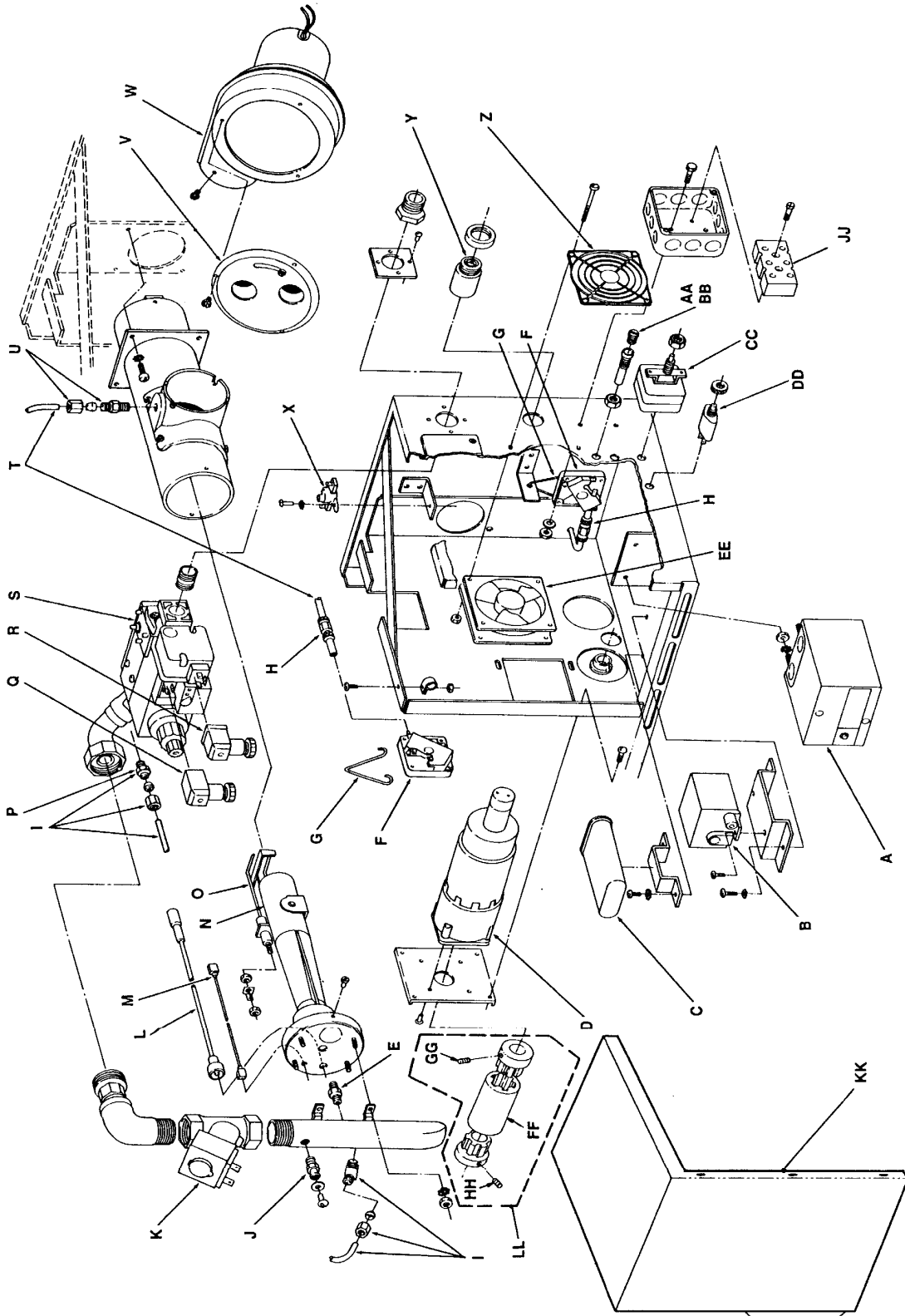

**CONTROL COMPARTMENT – REAR
MODELS 1152 THRU 1158 S/N 2011821 AND ABOVE**

LETTER	P/N	DESCRIPTION
A	369771	Reset Switch, Ignition Control
B		Thermostat, Oven Cavity Hi-Limit
	369583	For Models 1152,1153
	357067	For Models 1154 thru 1158
C	369664	Sleeve Only, Coupling Assembly
D	369268	Set Screw
E	369269	Ball Plunger Screw
F	369611	Coupling Assembly
G	369603	Stepper Motor Assembly, See Page 116 for Breakdown
I	369566	Main Orifice Only – Models 1152,1154,1157
	369524	Main Orifice Only – Models 1153,1155,1158
J	369561	Bypass Tube Assembly
		For Models 1152,1154,1157
	369562	For Models 1153,1155,1158
K	369689	Plug, Pressure Test
L	369398	Solenoid Valve 1154-1158
	369889	Solenoid Valve 1152-1153
M	369656	High Voltage Lead, Spark Igniter
N	369657	Flame Sensor Lead
O	369654	Venturi Tube, Natural
	369939	Venturi Tube, L.P.
P	369590	Igniter Sensor Probe
Q	369575	Air Switch
R	369786	Ball Chain, Air Switch
S	369556	Bypass Orifice Models 1152,1154,1157
	369557	Bypass Orifice Models 1153,1155,1158
T	369571	Connector, 4 Pole
U	369570	Connector, 3 Pole
V	369580	Gas Valve, Multi Block
W	370091	Support Bracket, Air Switches
X	369576	Flareless Tube Fitting
Y	369578	Hose
Z	369917	Connector, Male, ¼" tube to 1/8" pipe
AA	369401	Air Shutter Assembly
BB	369589	Burner Blower Motor Assembly
CC	369331	Finger Guard
DD	369579	Solid State Alarm
EE	357107	Fuse Holder
	369335	1 Amp Fuse
	369013	3 Amp Fuse
	369014	10 Amp Fuse
FF	369137	Circuit Breaker, 0.2 Amp
GG	369124	Cooling Fan
HH	369573	Ignition Control
II	369574	Spark Generator
JJ	369376	Terminal Block 3 Pole
KK	369192	Capacitor

OVEN BACK ASSEMBLY – 1100 SERIES

LETTER	P/N	DESCRIPTION
A	369182	Fan
B	369899	Shroud, Fan
C	369655	Stand Off
D	369560	Heating Element (200V) Orange
	369183	Heating Element (208V) Red
	369521	Heating Element (220V) Yellow
	369184	Heating Element (240V) Blue
E	369549	Rear Wall Electric Oven
	369976	Rear Wall Gas Oven
F	369581	Motor Support Assembly
G	369181	Motor, Main Fan 208/240V 60HZ
	369196	Motor, Main Fan 240V 50 HZ
	369539	Motor, Main Fan 120V 60 HZ
H	369695	Clamp, Bracket
I	369033	Clamp, Motor
J	369674	Rear Cover Assembly Electric Ovens S/N 2011383 and Below
	370049	Rear Cover Assembly All Ovens S/N 2017384 to 2019884
	369681	Rear Cover Assembly All Ovens S/N 2019885 and Above
	369540	Rear Cover Assembly, Model 1116,1117 S/N 2011383 and below
	369675	Rear Cover Assembly Model 1152-1158 S/N 2011383 and Below
K	369979	High Limit Bracket
L	369227	Catch Spring
M	369541	Thermocouple/Thermistor Bracket

OVEN BACK ASSEMBLY – 1100 SERIES BLOW UP

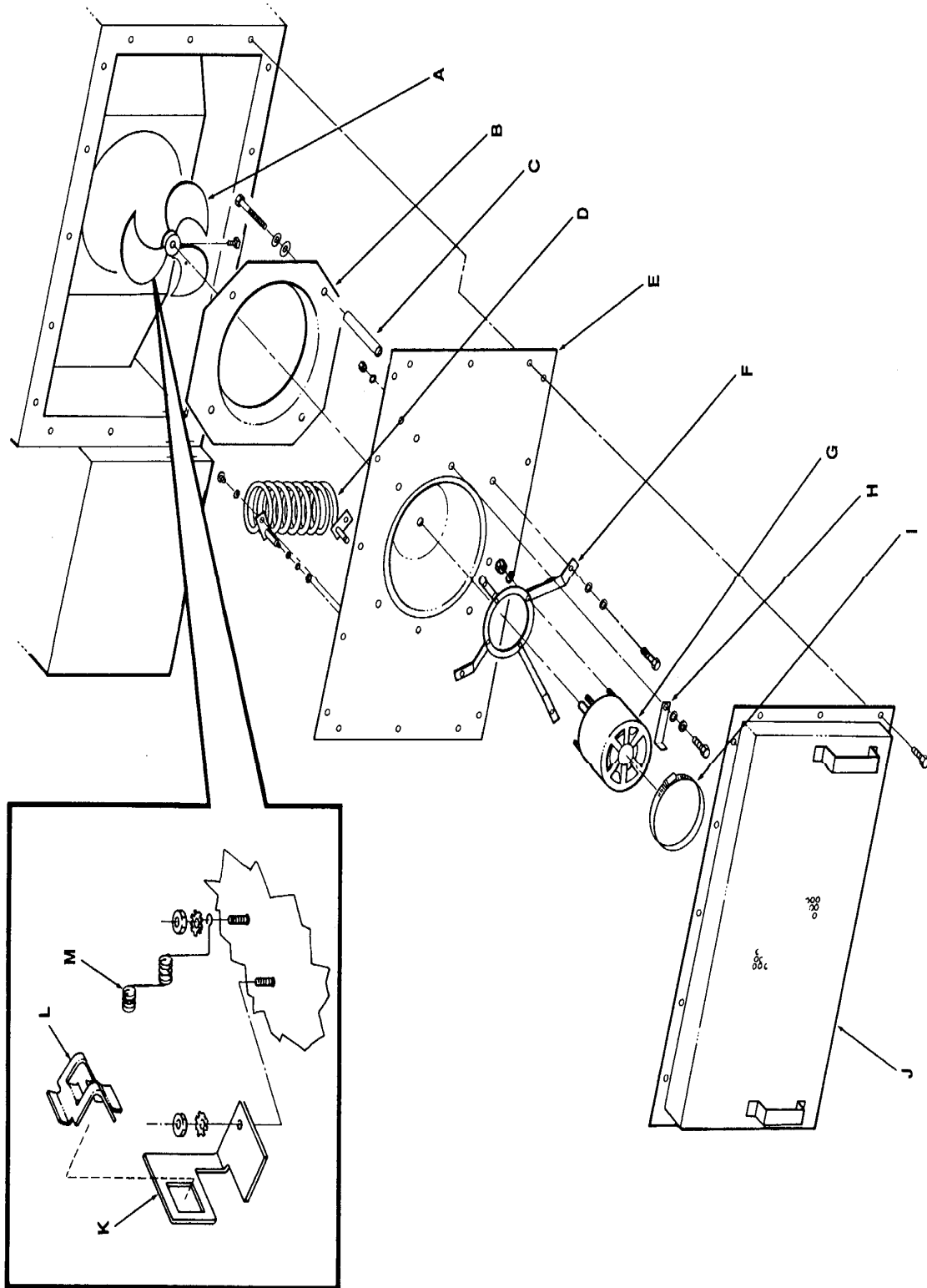

GEARMOTOR ASSEMBLY – 1100 SERIES

LETTER	P/N	DESCRIPTION
A	369519	Motor, DC –Conveyor
	369384	Motor Brush
B	369294	#4 Lock Washer
C	369296	Screw, 4-40 x ¼
D	369290	Optical Encoder Assembly
E	369151	Coupling And Encoder Disc (.050" Allen Wrench Included)
F	369146	Hex Nut, 4-40
G	369294	#4 Lock Washer
H	369292	Bracket, Tach. Generator
I	369297	Screw, 6-32 x ¼
J	369156	#6 Lock Washer
K	369293	Screw, 4-40 x 3/8
L	NLA	Tach Generator (Replace with 370216)
M	369298	Dust Cover
N	369299	Bushing
O	350247	Screw, 10-32 x 3/8
P	369295	#10 Lock Washer
Q	369603	Stepper Motor Gearbox Assembly (Includes R,S,T)
R	369737	Hall Effect Sensor
S	369658	Screw, 8-32 x ¼
T	369736	Magnet 2 Pole

GEARMOTOR ASSEMBLY – 1100 SERIES BLOW UP

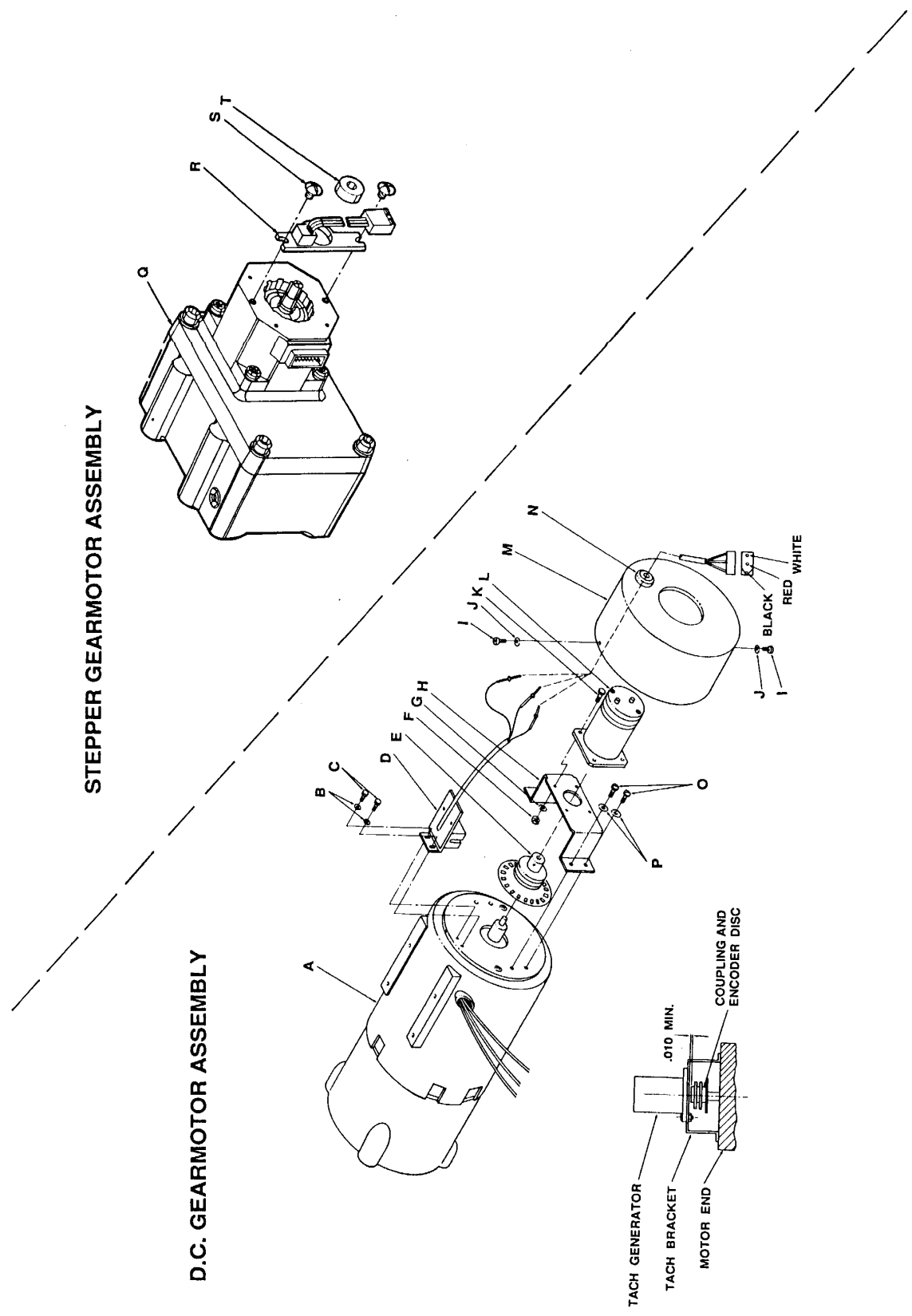

CONVEYOR/DOOR – 1100 SERIES

LETTER	P/N	DESCRIPTION
A	369190	Conveyor Drive Coupling Model 1100-1106 All Model 1116-1117 S/N 2011382 and Below Model 1130-1151 S/N 2011382 and Below Model 1152-1158 S/N 2011820 and Below Model 1160-1163 S/N 2011977 and Below
	369611	Conveyor Drive Coupling Model 1116-1117 S/N 2011383 and Above Model 1130-1151 S/N 2011383 and Above Model 1152-1158 S/N 2011821 and Above Model 1160-1163 S/N 2011978 and Above
B	369512	Coupling Center Model 1100-1106 All Model 1116-1117 S/N 2011382 and Below Model 1130-1151 S/N 2011382 and Below Model 1152-1158 S/N 2011820 and Below Model 1160-1163 S/N 2011977 and Below
	369664	Coupling Center Model 1116-1117 S/N 2011383 and Above Model 1130-1151 S/N 2011383 and Above Model 1152-1158 S/N 2011821 and Above Model 1160-1163 S/N 2011978 and Above
C	369269	Ball Plunger
D	369268	Set Screw
E	369223	Crumb Pan, Right
F	369224	Crumb Pan, Left
G	369666	Conveyor Frame Assembly
H	369226	Pan Stop
J	369516	Conveyor Bearing
K	369514	Idler Shaft
L	369515	Sprocket
	369978	Set Screw
M	369238	Drive Shaft
N	369513	Hinge
O	369510	Door Assembly, Includes N,P,& Q
P	370016	Impinger Nameplate
Q	369501	Door Latch & Catch
R	1123D	Door with Window Includes N,P,& Q
S	369927	Window Frame Top
T	369925	Glass Access Window
U	369926	Window Frame Bottom
W	369929	Retainer, Window
X	369165	Splice Clips
Y	369194	Conveyor Belt, Complete
	369394	Conveyor Belt, 1 Foot Section

CONVEYOR/DOOR - 1100 SERIES BLOW UP

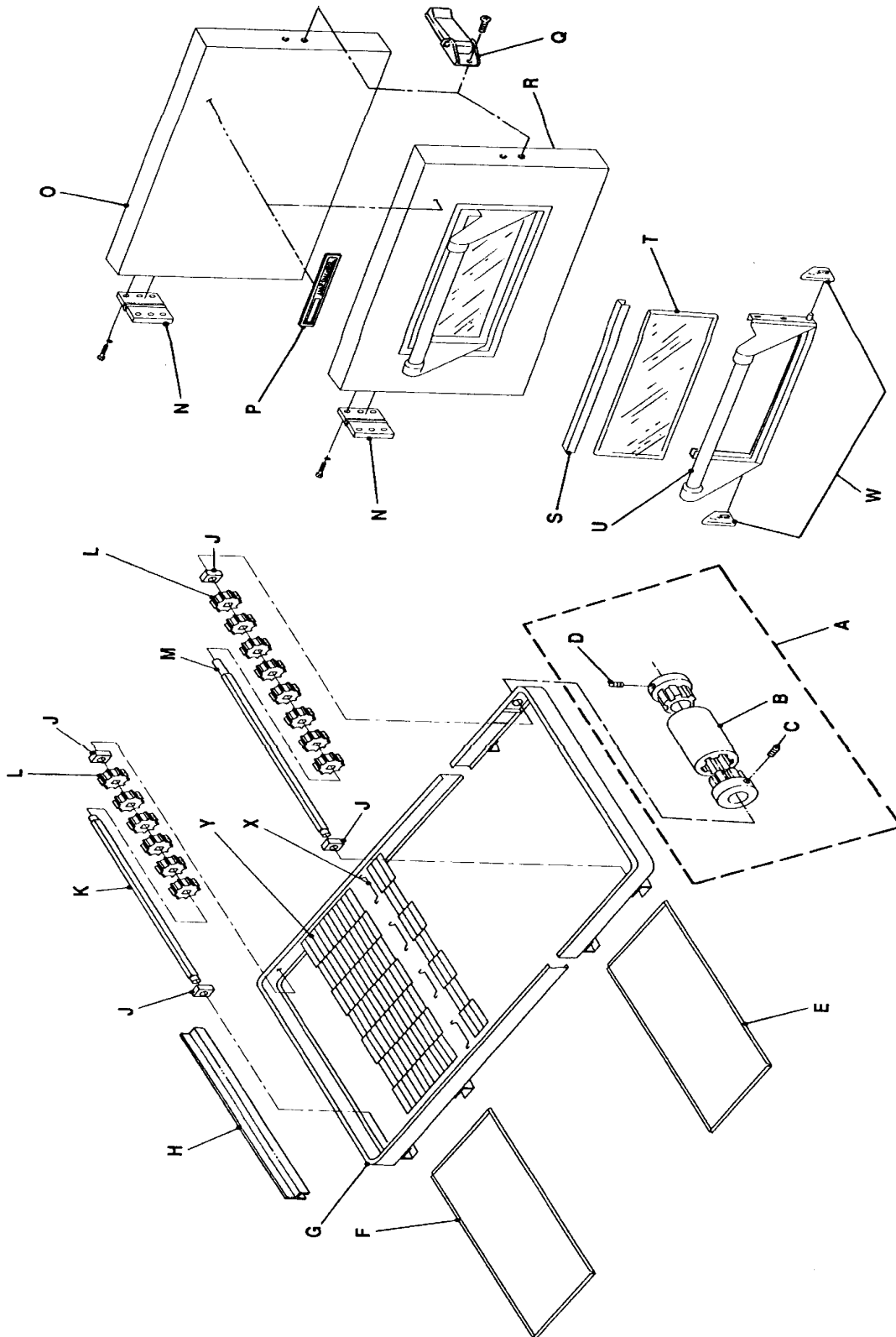

This page intentionally left blank.

This page intentionally left blank.

