

Visual Holding Cabinet

(MHA, MHD, MHG, MHL, MHS, MHT)

Service Manual

This manual is updated as new information and models are released. Visit our website for the latest manual.



8 1 9 7 9 5 6

Part Number: MER_SM_8197956 11/2021

Safety Notices

⚠ Warning

Read this manual thoroughly before operating, installing or performing maintenance on the equipment. Failure to follow instructions in this manual can cause property damage, injury or death.

⚠ DANGER

Do not install or operate equipment that has been misused, abused, neglected, damaged, or altered/modified from that of original manufactured specifications.

⚠ DANGER

Keep power cord AWAY from HEATED surfaces. DO NOT immerse power cord or plug in water. DO NOT let power cord hang over edge of table or counter.

⚠ Warning

Authorized Service Representatives are obligated to follow industry standard safety procedures, including, but not limited to, local/national regulations for disconnection / lock out / tag out procedures for all utilities including electric, gas, water and steam.

⚠ Warning

Do Not Store Or Use Gasoline Or Other Flammable Vapors Or Liquids In The Vicinity Of This Or Any Other Appliance. Never use flammable oil soaked cloths or combustible cleaning solutions, for cleaning.

⚠ Warning

This product contains chemicals known to the State of California to cause cancer and/or birth defects or other reproductive harm. Operation, installation, and servicing of this product could expose you to airborne particles of glasswool or ceramic fibers, crystalline silica, and/or carbon monoxide. Inhalation of airborne particles of glasswool or ceramic fibers is known to the State of California to cause cancer. Inhalation of carbon monoxide is known to the State of California to cause birth defects or other reproductive harm.

⚠ Warning

Do not use electrical appliances or accessories other than those supplied by the manufacturer.

⚠ Warning

Use caution when handling metal surface edges of all equipment.

⚠ Warning

This appliance is not intended for use by children under the age of 16 or persons with reduced physical, sensory or mental capabilities, or lack of experience and knowledge, unless they have been given supervision concerning use of the appliance by a person responsible for their safety. Do not allow children to play with this appliance.

⚠ Warning

DO NOT use this product near water – for example, near a kitchen sink, in a wet basement, near a swimming pool, or similar locations.

NOTE: Proper installation, care and maintenance are essential for maximum performance and trouble-free operation of your equipment. Visit our website www.mercoproducts.com for manual updates, translations, or contact information for service agents in your area.

Table of Contents

Section 1 General Information

| | |
|--|------------|
| Model Numbers | 1-1 |
| Serial Number Information | 1-1 |
| Service Personnel | 1-1 |
| Warranty Information..... | 1-1 |

Section 2 Operation

| | |
|--------------------------------|------------|
| Power Switch..... | 2-2 |
| User Interface | 3-2 |
| Passwords..... | 2-2 |
| Press & Go Screens | 2-2 |
| Tray Tracking..... | 2-4 |
| Tray Specifications..... | 2-5 |
| Menu Screens..... | 2-7 |
| USB Screens | 2-10 |
| Setting Screens | 2-11 |
| Preferences Screen | 2-11 |
| Date & Time Screen..... | 2-12 |
| Language Screen | 2-12 |
| Cabinet Names Screen..... | 2-13 |
| Networking Screens | 2-13 |
| Zone Diagnostics Screens..... | 2-14 |
| Errors Log Screen | 2-15 |
| Holding Log Screen..... | 2-15 |
| Password Settings Screen..... | 2-15 |
| System Information Screen..... | 2-16 |
| Utilities Screen | 2-16 |
| Load Software Via USB..... | 2-17 |

Section 3 Maintenance

| | |
|---|------------|
| Cleaning and Sanitizing Procedures | 3-1 |
| General | 3-1 |
| Exterior Cleaning | 3-1 |
| Interior Cleaning | 3-2 |
| Plastic Tray Cleaning | 3-2 |
| Daily Cleaning Instructions..... | 3-2 |
| Component Identification..... | 3-4 |
| Instructions For Replacing a Heater Pad | 3-5 |
| Instructions For Replacing a Touch Screen | 3-5 |
| Instructions For Replacing an IO Board | 3-6 |
| I/O Board Switch and Jumper Settings..... | 3-6 |
| RFID Reader Board | 3-7 |
| I/O Board | 3-8 |
| Thermocouple Connections and Zones..... | 3-9 |

Section 4
Troubleshooting

Troubleshooting..... 4-1
Zone Diagnostics 4-1
Power Issues Troubleshooting..... 4-2
Communication Issues Troubleshooting..... 4-3
Temperature Too Low/Self Temp Low Issues Troubleshooting 4-4
Temperature Too High Issues Troubleshooting 4-5
Display Issues Troubleshooting 4-6
Product Mismatch/Pan Sensing Issues Troubleshooting 4-7
Product Mismatch/Pan Sensing Issues Troubleshooting cont. 4-8
Network and ID Connector Issues Troubleshooting 4-9
Heater/Thermocouple Troubleshooting..... 4-10
Common Error Messages 4-10

Section 5
Wiring Diagrams

MHG - 2x2 5-1
MHS - 2x2..... 5-2
MHG - 2x3 5-3
MHA/MHD - 3x2 5-4
MHD - 3x2 RFID 5-5
MHG - 3x2 5-6
MHG - 4x2 5-7
MHD - 4x2 5-8
MHD - 4x2 RFID 5-9
MHD - 8x2 5-10
MHD - 8x2 RFID 5-11

Section 1

General Information

Model Numbers

| Models | Description |
|---------------|--------------------------------------|
| MHG22SAT1W | 2x2 - Front Display |
| MHG22SAT2W | 2x2 Front and Rear Display |
| (X)MHS22SAT1W | 2x2 - Front Display |
| MHG23SAT1W | 2x3 - Front Display |
| MHG23SAT2W | 2x3 Front and Rear Display |
| MHG32SAT1W | 3x2 Front Display |
| MHA32SSL1W | 3x2 Front Display Landscape |
| MHG32SAT2W | 3x2 Front and Rear Display |
| MHA32SSL2W | 3x2 Front and Rear Display Landscape |
| MHD32SST1T | 3x2 Front Display |
| MHD32SST2T | 3x2 Front and Rear Display |
| MHG42SAT1W | 4x2 Front Display |
| MHG42SAT2W | 4x2 Front and Rear Display |
| MHD42SSL1T | 4x2 Front Display Landscape |
| MHD82SST1T | 8x2 Front Display |

Serial Number Information

MHG/MHA/MHD/MHS visual holding cabinet serial and model numbers are located on the data plate. The data plate is located on the top right rear of the unit.

Always have the serial number of your unit available when calling for parts or service.

Service Personnel

All service on Merco equipment must be performed by qualified, certified, licensed, and/or authorized or service personnel.

Qualified service personnel are those who are familiar with Merco equipment and who have been authorized by Merco to perform service on the equipment. All authorized service personnel are required to be equipped with a complete set of service and parts manuals, and to stock a minimum amount of parts for Merco equipment. A list of Merco Factory Authorized Servicers (FAS's) is located on the Merco website at <http://www.mercoproducts.com/Service#Service>. Failure to use qualified service personnel will void the Merco warranty on your equipment.

Understanding Model Numbers

| M | H | G | 2 | 3 | S | A | T | 1 | W |
|-------|-------------|----------|----------------|---------------------------|------------|------------|---------|---------------|--------------|
| Merco | Hot Holding | Customer | Rows (Shelves) | Columns (Trays per shelf) | Lower Heat | Upper Heat | Display | Control Faces | Connectivity |
| | | | | | | | | | |

Warranty Information

Visit <http://www.mercoproducts.com/Service#Warranty> to:

- Register your product for warranty.
- Verify warranty information.
- View and download a copy of your warranty.

Section 2 Operation

⚠ DANGER

The on-site supervisor is responsible for ensuring that operators are made aware of the inherent dangers of operating this equipment.

⚠ DANGER

Do not operate any appliance with a damaged cord or plug. All repairs must be performed by a qualified service company.

⚠ DANGER

Never stand on the unit! They are not designed to hold the weight of an adult, and may collapse or tip if misused in this manner.

⚠ Warning

Do not contact moving parts.

⚠ Warning

All covers and access panels must be in place and properly secured, before operating this equipment.

⚠ Warning

Do not put heat sealed containers or plastic bags in holding cabinet. Food or liquid could expand quickly and cause container or bag to break. Pierce or open container or bag before heating.

⚠ Warning

Racks, utensils, rack guides, and holding cabinet surfaces may become hot during or after use. Use utensils or protective clothing, like pan grips or dry oven mitts, when necessary to avoid burns.

⚠ Warning

DO NOT use the cavity for storage. DO NOT leave paper products, cooking utensils, or food in the cavity when not in use.

⚠ Caution

DO NOT cover racks or any other part of the holding cabinet with metal foil.

The Merco Visual Holding Cabinet has been designed to afford food service operators the ability to cook menu components in advance and then gently store that product in the holding bins until an order is received. Once that order has been placed, the crew can assemble the order using hot and fresh menu components from the holding bins. This allows for operators to serve to order, helping increase speed of service while maintaining high product quality standards.

Power Switch

The power switch is located on the front of the cabinet. Flip the power switch to turn the unit on or off.

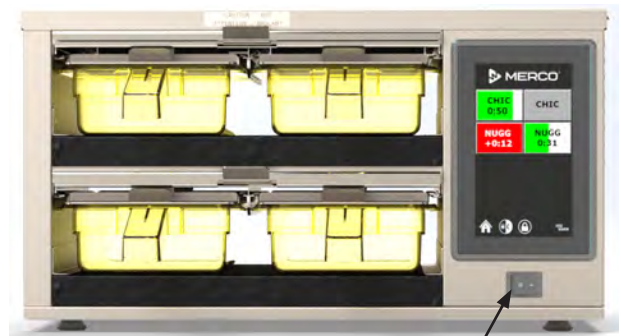

Power Switch on Front

User Interface

PASSWORD

- A user can access all necessary screens for daily operation without a password.
- The factory default manager password is 2580.
- The service password is 159357.

PRESS & GO SCREENS

When the unit is turned on zone pre-heating will begin. The press and go screen will be displayed. The holding cabinet has a default menu and zone assignment. The holding cabinet will heat up to the pre-set default temperatures. Please continue to follow the directions in this manual to customize menu items using the touch screen, or visit <https://www.welbiltdigital.com> for access to the on-line MenuConnect application.



Press & Go Screen Pre-Heating

The unit will beep signaling that all holding zones are pre-heated and ready for use.

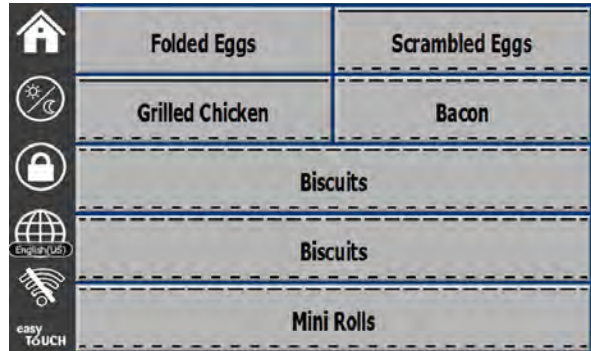

Press & Go Screen

As trays of food are loaded into the cabinet and the corresponding timers are pressed on the touch screen, they will be highlighted in green and the product timers will start.

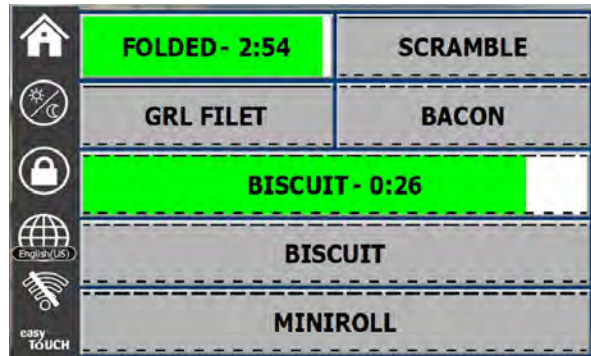

Press & Go Screen with Active Timers

The green portion of the tray timer represents the remaining time. Each menu item has a programmed warning time. When the warning time is reached the elapsed time will fill in with yellow and the alarm will beep.

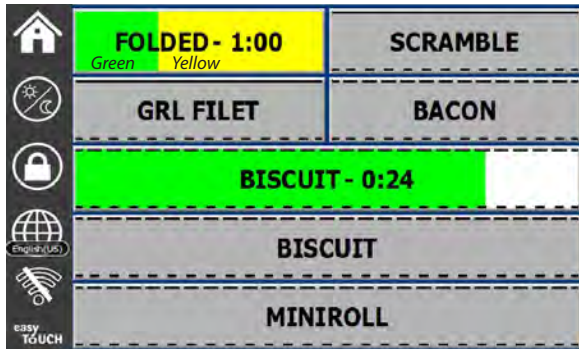

Top Left Zone Reaches the Warning Time

The alarm will beep for 10 seconds. The timer will display time the product is being held past programmed hold time. Tray and food should be removed. Reset the expired tray timer by selecting it.

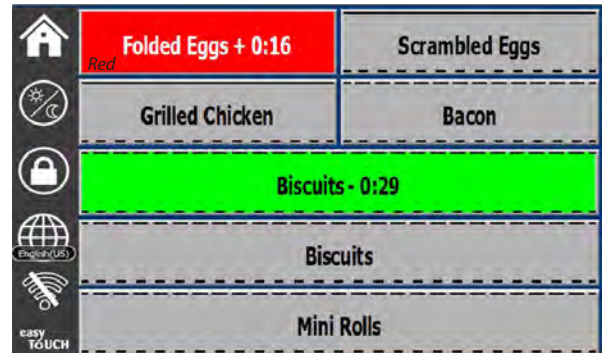

Top Left Zone Runs Over Hold Time

Each menu item has a programmed hold time. When the times runs out the corresponding tray timer will turn red and the alarm will beep.

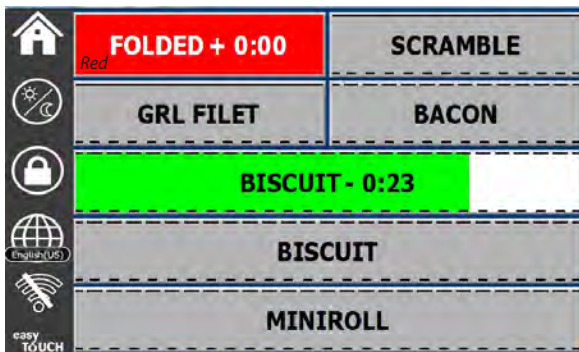

Top Left Zone (#9) Runs out of Hold Time

When necessary select a tray timer to reset it before the hold time has expired. The question Reset? will pop up. Select the green check to reset. Select the red X to resume.

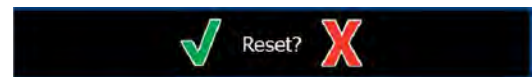

Reset Pop Up

If the cabinet has optional tray tracking, as the trays are removed and returned to the same cabinet or between communicating holding cabinets, they will be detected. Their timer will continue whether they are sitting on the counter or traveling between hot holding cabinets.

TRAY TRACKING

Press & Hold Transfer (Manual)

To manually transfer a food item to an empty holding position, press and hold the empty position for ~2 seconds. The following pop-up screen will display (if the manual transfer is not completed within a few seconds, it will revert back to the previous timers and locations). All available active timers for the empty position that is chosen, will be in the pop-up list.



Choose the active timer of the food you want to move to that empty position and press the green CHECK button. The active timer will now be in the new position. This feature is helpful if you always want to pull from a certain position, and load from the top. For example, if the procedure is to always pull from the lowest position, once the lowest position is empty, reset the time, then press and hold the location button for ~2 seconds and move the next green timer to the lowest position. Refill the upper position and start a new timer.

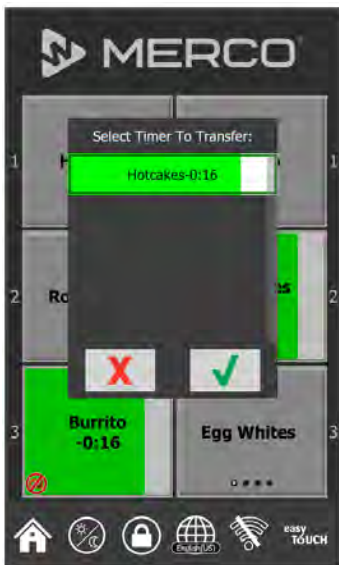

The icon in the lower left corner is displayed if a timer is manually started on a cabinet that has Tray Tracking Technology (TTT). If a TTT tray was inserted, this icon would not be present.

Tray Tracking Technology (TTT) Transfer (automatic, transfer with special TTT plastic trays) – Tray Tracking

Plastic holding trays with built-in TTT automatically start the timer when inserted into a corresponding food position. If the tray is removed and moved to an empty corresponding food position, the timer will automatically transfer. If the tray is removed and moved to a non-matching food position, “Product Mismatch” will flash and an error signal will sound.

TRAY SPECIFICATIONS

Use First For Identical Products

When two identical products are active, the one with the least time remaining will be highlighted in green, the others in dark gray. There is no change in countdown or timer behavior. When the first item is canceled or reset, the next one in order will turn green.

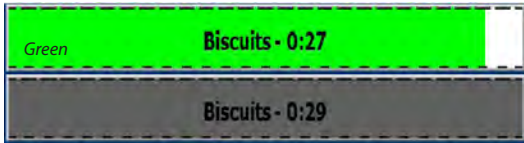

Use Highlighted Tray First

Lid Requirements

- No line above the product name means no lid.

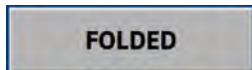

- A dashed line above the product name represents a vented lid.

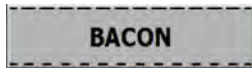

- A solid line above the product represents a solid lid.

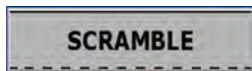

False Bottom Requirements

- No line below the product name means no false bottom or a trivet is in the tray.



- A dashed line below the product name means to use a false bottom or trivet.

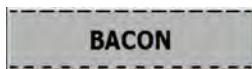

A Group in the Menu

A product in the menu is part of a group if there are dots underneath it or arrow heads on either side of it. Select the menu item with the dots and the other items in the group will pop up and can be selected. Swipe a product with arrow heads to choose another item from the group.

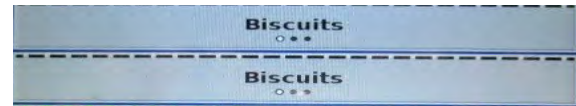

Press & Go Screen Icons

On the press and go screen are six icons:

- Home
- Day part
- Lock
- Language
- WiFi
- Easy touch logo



Press & Go Screen Five Icons

Select the home icon to bring up the home screen.



Home Icon



Home Screen

From the home menu selecting the press & go icon to return to the press and go screen.



Press & Go Icon

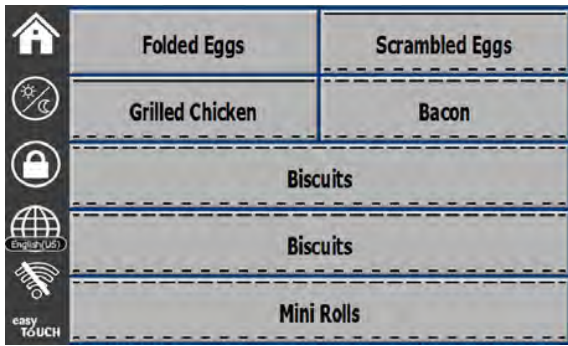

Press & Go Screen

Touch the daypart selection icon to choose a different menu. The menu options will pop up.



Daypart Selection Icon



Menu Pop Up

Active timers are carried over into the new menu. Once the item is reset the new product will show up. Waiting is displayed when the menu changes and the zone temperature is changing but there is still an active timer in the zone at the old temperature. The shelf is waiting to warm up to the new temperature until all active timers at the old temperature are cleared.



New Menu with Active Timers from Last Menu Highlighted

On press and go screen the lock icon disables the touch screen for 10 seconds. The lock icon must be held for 1 second to disable the screen. In the center of the lock graphic the 10 seconds will be counted down. Ten seconds of disabled screen allows time for the touch screen to be cleaned.



Lock Icon

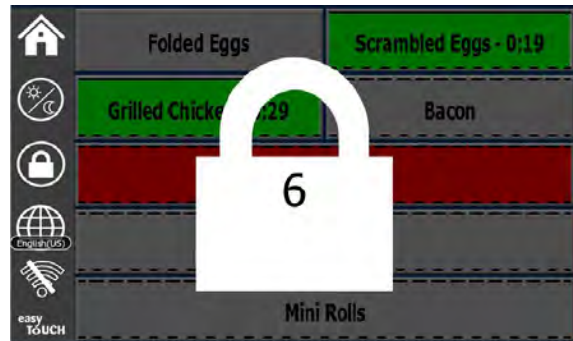

Press & Go Screen Locked for Screen Cleaning

The Wi-Fi Icon indicates the Wi-Fi and local network status of the machine and others in the kitchen.



Wi-Fi Icon

A line through the icon indicates the unit is not connected to the Wi-Fi.

A one means the unit is connected to Wi-Fi and the local area network and that it is the only Merco unit connected to that network.

Numbers two and higher indicate the quantity of units that are connected to Wi-Fi and that local area network.

MENU SCREENS

From the home screen selecting the menu icon brings up the menu screen. The menu screen lists the products saved in the hot holding unit. 100 products can be saved.

To make changes on the three menu pages a passcode must be entered. Select the lock on the bottom left of the screen. Enter a passcode on the pop-up number pad. If the passcode is accepted the lock icon will appear unlocked. To return to the home screen select the back arrow.

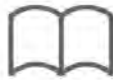

Menu Icon

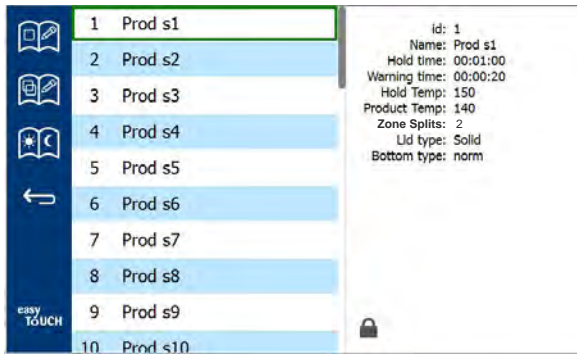

Menu Screen

If the pages are unlocked, the delete, edit and add icons will display on the menu screen.



Unlocked, Delete, Edit & Add Icons

Select the unwanted product and then the delete icon, X. A confirmation window will pop up. Select the green check to delete the product. Select the red X to return to the menu screen.

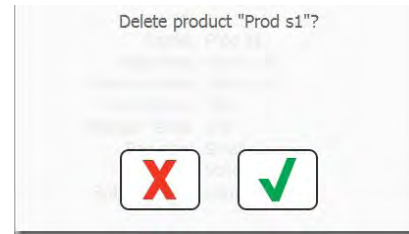

Delete Product Confirmation Window

When a product is edited or added, required specifications include:

- Name:
- Hold Temp: tray temperature maintained $\pm 5^{\circ}\text{F}$
- Product temp: reference only, not measured
- Hold time: maximum time product can be held & served
- Warning time: alarm will sound when the tray has this length of time *remaining*. The elapsed time on the timer bar changes color from white to yellow
- Zone Splits: 2 represents a full size pan (full zone), 1 represents a 1/3 size pan (half zone)
- Lid type: None, Solid or Vented
- Bottom type: Normal or False

Save the edit or product addition by selecting the check. Select the x to cancel edits and return to product list.

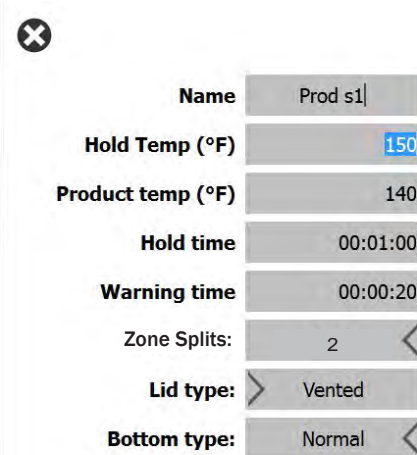

Product Edit or Addition Screen

On the menu screen are navigation icons.

- The first icon returns you to the product list screen.
- The second takes you to the group list screen .
- The third takes you to the day part edit screen.
- To return to the home screen select the back arrow.



Menu, Group, Day Part & Home Navigation Icons

Groups of products can be defined. The products must have the same lid type, zone split and hold temp. Hold time, warning time and product temp and can vary within a group.

From the menu screen, select the group icon. The group page lists programmed groups. For the highlighted group, group ID, group name, hold temperature, zone split, lid type and products included in the group are listed.



Group Icon

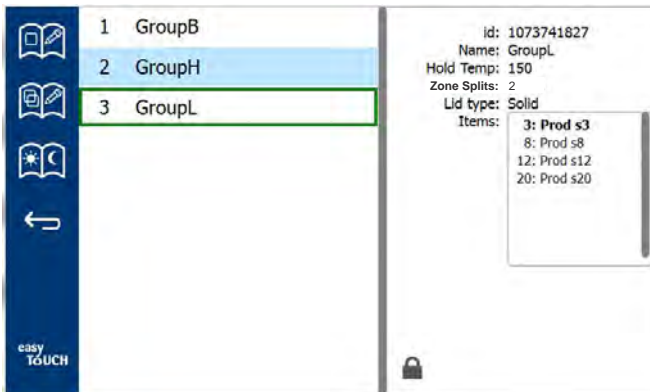

Group Screen

If the group page is unlocked, the delete, edit and add icons will display on the group screen.



Unlocked, Delete, Edit & Add Icons

Select the unwanted group and then the delete icon, X. A confirmation window will pop up. Select the green check to delete the group. Select the red X to return to the group screen.

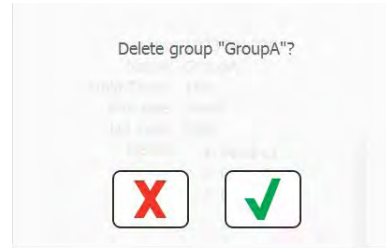

Delete Group Confirmation Window

Select the group to be edited and the edit icon, a pencil. In the pop up window the group will appear. You can edit the group name and add or remove products.

Click inside the name box and a keyboard will appear. When the group name is edited select the return key (bottom right).

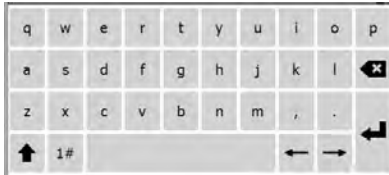

Pop Up Keyboard

Under the name are the group specifications. Only products that match will be highlighted and available for adding.

- Select a new product for the group and the green arrow to add it.
- Select an existing product in the group and the red arrow to remove it.
- To select the default product for the group (product to be displayed when the daypart is selected), hold your finger on that product for three seconds.
- While the unit is in the Press & Go mode the names can be scrolled from left to right in the same order as they are listed in the group top to bottom. Delete products and add them back in to create the desired order.

When the edits are complete return to the group screen by selecting the X in the top left corner.

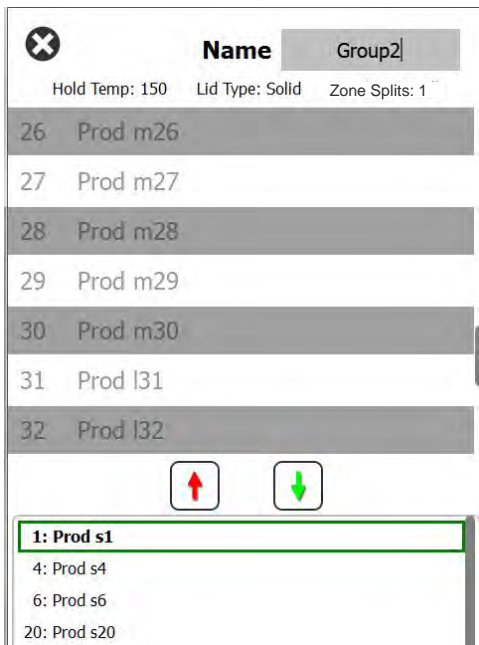

To add a group, select the group page add icon, +. A pop up window will appear. Click inside the name box and use the keyboard to enter the group name. Select the return key (bottom right) and the keyboard will close.

NOTE: Name groups so they are recognizable as groups, perhaps starting with G or Group. When editing the day parts to add the group, the name is all that is displayed in the scrolling list. If it does not stand out as a group it will appear as just another product.



Pop Up Keyboard

Select a product for the group and the green arrow to add it. That first product will determine the group specifications, listed under the group name. Going forward product with the wrong specifications, not available to be added to the group, will be grayed out. Continue to add products to the group. To remove a product, select it and the red arrow.

When the group is complete save it and return to the group screen by selecting the X in the top left corner.

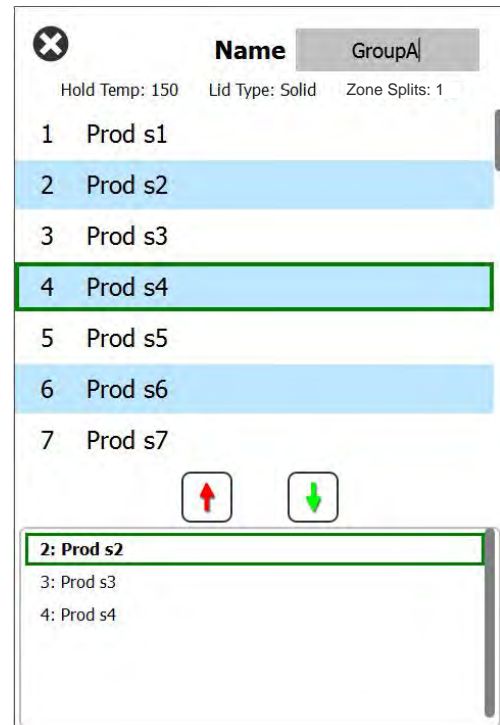

On the menu screen are navigation icons. Next to the back arrow is the day part edit icon.



Day Part Edit Icon

Select the day part edit icon and the breakfast products appears first. Swipe the screen to move between breakfast and lunch/dinner.

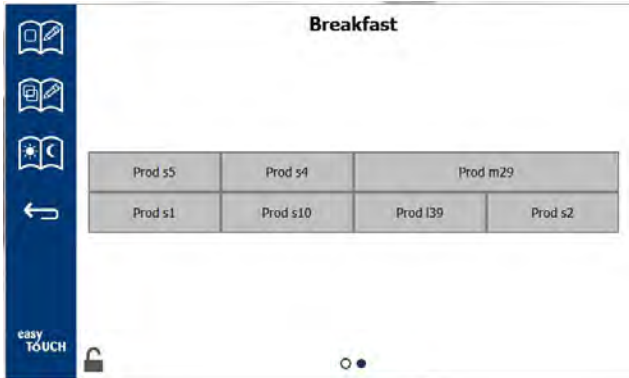

Breakfast Products

To delete a product from a zone hold your finger on the product for three seconds. A pop-up window confirms the request to delete.

Select a hot holding zone to add a product or change the product. From the pop up window select the product you want to add to the zone. Groups can also be added. Zone split and zone temperatures will eliminate certain products. Products not available will be grayed out. Select the green check to save and return.

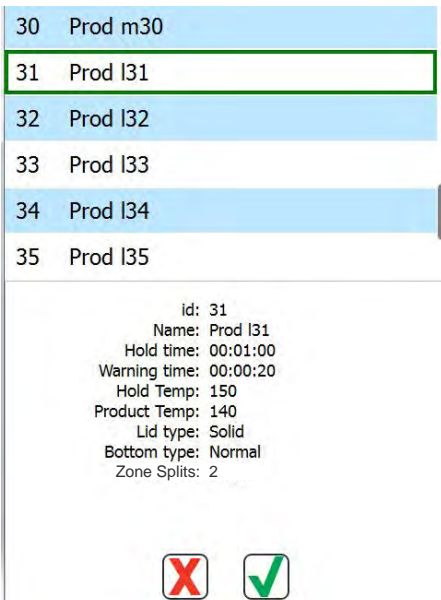

Selecting A Product For Breakfast Zone 3

USB SCREEN

From the home screen selecting the USB icon brings up the USB screen. A passcode needs to be entered to upload a new menu file.



USB Icon



Once a correct passcode is entered, a yellow frame surrounds the screen and the lock icon will show as unlocked. A USB with the proper type of menu file (.VHC) must be inserted into the external USB port for this action to work properly.

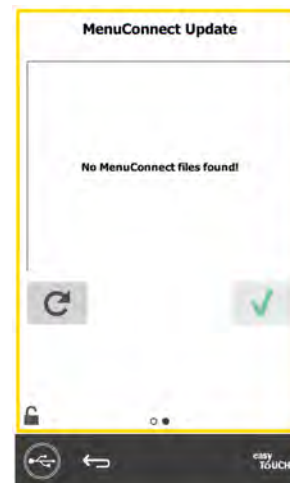

SETTINGS SCREENS

From the home screen selecting the settings icon brings up the preferences screen. This is the first of eleven setting screens. There are eleven solid dots across the bottom of the service screens, the empty circle represents the current page. Touch the dots to bring up a menu. Select and navigate to a specific screen from the menu. Or navigate between the screens by swiping the screen to the right or left.



Settings Icon

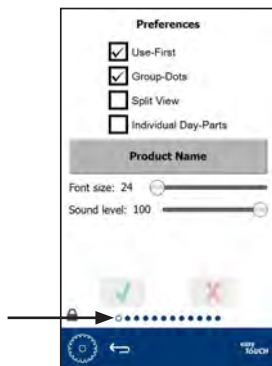

Preferences Screen With Row of Dots

- Preferences
- Date & Time
- Language
- Cabinet Names
- Wi-Fi Networking
- Zone Diagnostics
- Errors Log
- Holding Log
- Password
- System Information
- Utilities

Settings Screens Menu

PREFERENCES SCREEN

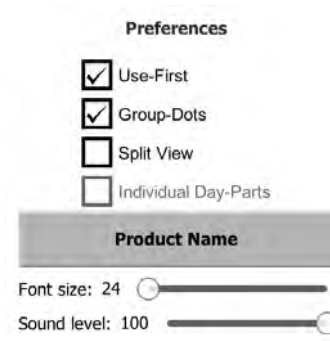

Preferences Screen

- Select the green check to implement changes, red cross to discard.
- Use First – When checked the first tray of common product will be highlighted in green, second tray will be gray until the first tray is gone or time runs out. Unchecked, both trays of the common product will be green.
- Group Dots - When checked the number of dots indicate the number of products in that group. The empty circle indicates the position of the current product. Select different products by swiping the screen right or left.
- Split View - When checked displays both items when a group has only two items, the display is split in half. It is not necessary to swipe between the two items. The screen space to select the item has been halved, be careful to choose the desired item. Unchecked the two item group will display like other groups.
- Font size can be adjusted between 24-48.
- Volume can be adjusted between 10-100.

DATE & TIME SCREEN

To make changes on the this screen a passcode must be entered. Select the lock on the bottom left of the screen. Enter a passcode on the pop-up number pad. If the passcode is accepted there will be a yellow ring around the screen.

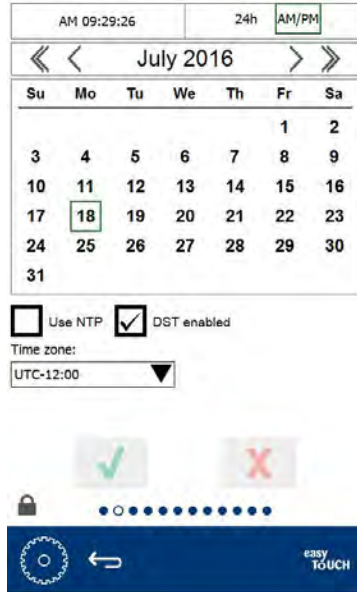

Date & Time Screen

- If the NTP box is checked and the unit is connected to the internet via the local WiFi, the date and time will be set automatically. Be sure to set the UTC to the appropriate setting (i.e. Eastern Standard time is UTC -5:00, Central Time is UTC -6:00). If the unit is not connected to the internet or if the NTP box is unchecked the time and date will need to be set manually.
- Top right of the screen provides the choice between a 24hr/military and AM/PM civilian time display.
- Select the month and year by the arrow heads and the date via the calendar.
- If the DST enabled box is checked the time on the clock will be moved ahead by 1 hour. If the box is checked and then unchecked the time on the clock will move back one hour. Proper use of this feature is to check the box on the first day of daylight savings time and uncheck the box on the day after daylight savings time ends.
- Time Zone - Use the drop down box to select the time zone the equipment is being used in. This only has an effect on the date and time setting if the Use NTP box is checked.

LANGUAGE SCREEN



Language Screen

Available languages are listed to choose from. Store or company created menu items will not change to the new language. Only the headings and descriptions will change to the new language (i.e. service page titles, calendar month names, product parameters, and menu page titles).

CABINET NAMES SCREEN (USED ONLY IN LOCATIONS WITH MULTIPLE CABINETS AND OPTIONAL TRAY TRACKING)

To make changes on the this screen a passcode must be entered. Select the lock on the bottom left of the screen. Enter a passcode on the pop-up number pad. If the passcode is accepted there will be a yellow ring around the screen.

Choices for cabinet name are Reserve Cabinet and Point-of-Use Cabinet. Cabinet Index is a choice of numbers one through ten. Scroll left or right to make selections.



Cabinet Names Screen

All cabinets that are connected to the local WiFi and talking to the other cabinets will be listed in the box. If there are no other cabinets on the local network and this cabinet is connected to the WiFi only this cabinet will be in the list.

NETWORKING SCREENS

To make changes on the this screen a passcode must be entered. Select the lock on the bottom left of the screen. Enter a passcode on the pop-up number pad.

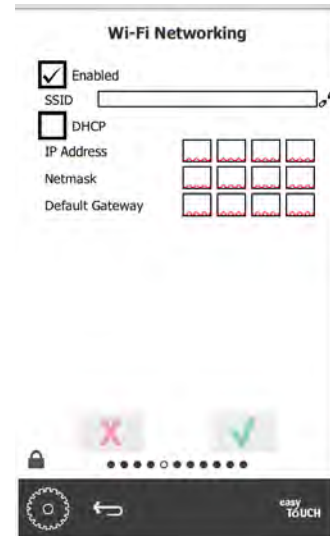

If the passcode is accepted there will be a yellow ring around the screen.

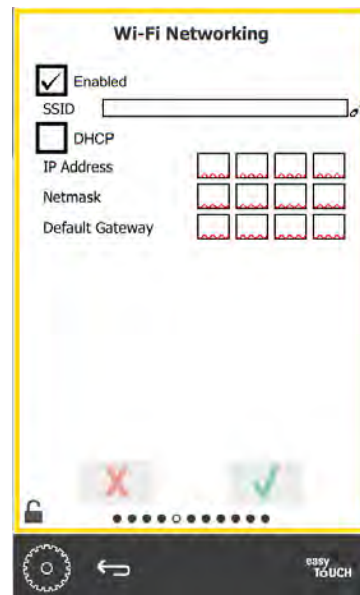

Wi-Fi Network Screen

To connect the Holding Cabinet to the local WiFi check both the Enable box and the DHCP box, then touch the box just to the right of SSID. That will open a new window that will allow the name and password of the WiFi network to be entered to connect the holding cabinet. See screen shot below.

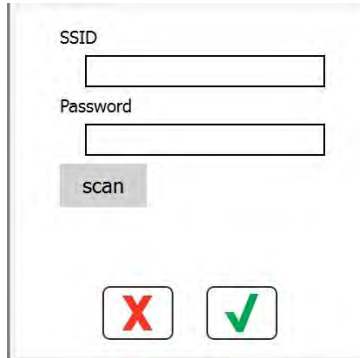

Wi-Fi Pop-up For Scanning

Touching the scan button will display a list of all WiFi SSIDs as well as their signal strength, that the cabinet is aware of. Touching the SSID box will bring up an alphanumeric keyboard to enter the SSID of the WiFi network to connect to. Touch the return button to return to the WiFi Pop-up For Scanning screen. Touch the Password box to enter the network password (special characters can be found on the 1# keyboard. Once on the 1# keyboard, more special characters can be found by touching the up-arrow key.

When finished entering SSID and Password touch the green check button to save your entries. Touch the green check button to connect to the WiFi network. Once connected the fields IP Address, Netmask, and Default Gateway will be populated, if these fields are not populated the holding cabinet is not connected to the WiFi network.

ZONE DIAGNOSTICS SCREENS

Holding cabinet temperatures can be monitored on this screen, no password is required to observe current heating element temperatures.

To run service tests on this screen a service passcode must be entered. Select the lock on the bottom left of the screen. Enter a service passcode on the pop-up numeric keypad. If the passcode is accepted there will be a yellow ring around the screen.

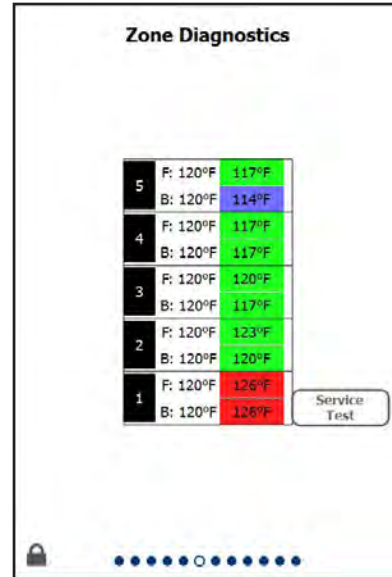

Zone Diagnostics Screen

Zone diagnostic screen shows set temperature and current unit temperature for each heating element. Current temperature will be highlighted green if +/- 5°F of the set temperature. Current temperatures are highlighted red if hotter than and blue if colder than set temperature.

1. Test the machine by changing set temperatures. The screen will have a red border while the testing.
 - Select Service Test to change the set temperatures to factory determined test temperatures.

OR

- Touch the a zone set temperature, highlighted in white. On the displayed numeric key pad, enter the desired temperature then touch the green check.

Note: Entering a temperature of 360 deg F or higher will cause the heating element to be ON all the time. Entering a temperature of zero deg F will turn the heating element OFF. The set temperature of both heating elements in the zone will be set to the same temperature.

2. Select Cancel Test when complete, the screen border will change to yellow.

ERRORS LOG SCREEN

This screen does not require a passcode.

| Errors Log | | | |
|---------------------|---------|----------------------------------|--|
| Date/Time | ID | Error name | |
| 2016/07/18 11:37:30 | 4.0.0.0 | Secondary UI communication loss. | |
| 2016/07/18 11:18:45 | 4.0.0.0 | Secondary UI communication loss. | |
| 2016/07/18 11:15:13 | 4.0.0.0 | Secondary UI communication loss. | |
| 2016/06/10 13:22:00 | 4.0.0.0 | Secondary UI communication loss. | |
| 2016/06/10 13:29:15 | 4.0.0.0 | Secondary UI communication loss. | |
| 2016/06/10 13:27:52 | 4.0.0.0 | Secondary UI communication loss. | |
| 2016/06/10 13:17:25 | 4.0.0.0 | Secondary UI communication loss. | |

Number of records: 7

First record: Last record:

Refresh Clear All

Errors Log Screen

Clear all button removes all entries on the errors log screen. Touching the Refresh button will update the error list. Swiping away from this page and then swiping back will also refresh the error log list with any new errors. This information can be exported if desired.

HOLDING LOG SCREEN

This screen does not require a passcode.

| Holding Log | | | | | |
|--------------|--------------|-------------|-----------|------------------|--|
| Product Name | Shelf Number | Start Time | Discarded | Holding Duration | |
| Hotcakes | 1 | 01/23 18:24 | No | 00:00 | |
| Hotcakes | 2 | 01/23 18:19 | No | 00:04 | |
| Burrito | 3 | 01/23 18:19 | No | 00:04 | |
| Burrito | 3 | 01/23 17:53 | Yes | 00:25 | |
| Hotcakes | 1 | 01/23 17:53 | Yes | 00:25 | |
| Burrito | 3 | 01/23 18:00 | — | — | |
| Burrito | 3 | 01/23 17:53 | No | 00:07 | |
| Hotcakes | 1 | 01/23 17:53 | No | 00:07 | |
| Round Eggs | 2 | 01/23 13:21 | No | 00:00 | |

Number of records: 9

Refresh

Errors Log Screen

This page displays the product name, start time, holding duration and if the timers were expired, according to each shelf location. This information can be exported if desired.

PASSWORD SETTINGS SCREEN

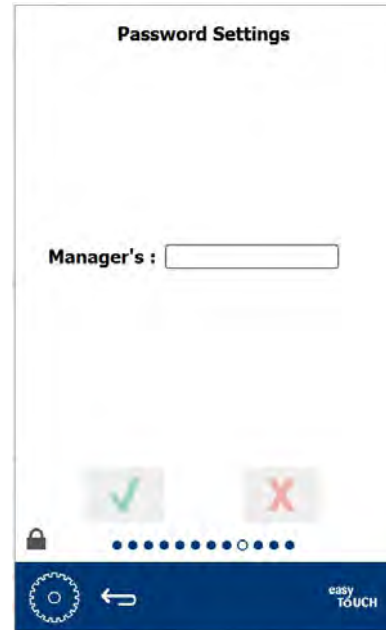

Password Settings Screen

There is a factory default manager passcode. It can be changed on the password service screen. Select the open box after Manager's: and a new pin # number pad will pop up. Enter the new manager's passcode and the green check to confirm.



New Pin # Number Pad

To reset the passcode back to the factory default quickly touch the easy touch logo 10 times in a row. At the end of 5 taps the menu bar will turn black, continue to tap. A pop up display will confirm the manager's pin # was reset.



Easy Touch Logo

SYSTEM INFORMATION SCREEN

This screen does not require a passcode, there are no actions available on this screen.

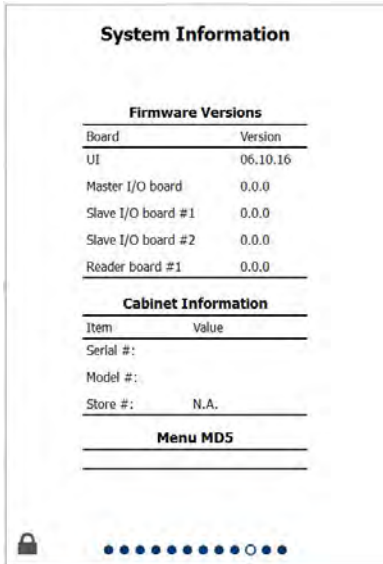

System Information Screen

This screen lists the cabinet serial number, model number and current firmware versions.

UTILITIES SCREEN



Sound Test – Three beeps should sound when the Sound Test button is pressed.

Screen Test – When the Screen Test button is pressed, user can swipe through three colorful screens to help diagnose screen functionality.

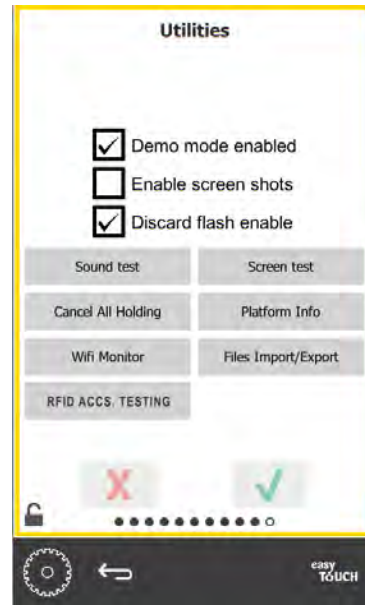

Utilities Screen

A service passcode 159357 is required to enter the advanced utilities menu.

Demo Mode Enabled – to run demo mode, a service passcode must be entered. Select the lock on the bottom left of the screen. Enter a service passcode on the pop-up number pad. If the passcode is accepted there will be a yellow ring around the screen. The demo mode will turn off all heaters and simulates operation at a lower amp draw. The unit will continue in demo mode until returned to normal operation via this screen, regardless of being powered off and on.

Enable Screen Shots – On Some Models – If selected, users can take screenshots of any page by double-clicking the easyTouch logo in the lower right corner of the screen.

Discard Flash Enable – If enabled, an expired product will be displayed by a flashing red box with the word “DISCARD” that will flash intermittently.

Cancel All Holding – If a tray with an active timer is removed and not returned to the unit, the active timer information will be stored in memory. Service may push the Cancel All Holding button to clear unnecessary information from the memory.

Platform Info – A pop-up screen lists firmware specifications including linux kernel and board support package, etc.

Wi-Fi Monitor – Not used at this time.

RFID ACCS. TESTING – This is used to test the Tray Tracking Technology. If RFID Accs. Testing is selected the screen will be blank. Place the tray in the upper left bin of the cabinet. The tone will sound and the name of the product as well as the color of the tray will be displayed on the screen (Both sides of the tray need to be tested).

Files Import/Export – Press this button for a list of available actions. Insert a USB into the external USB port. Choose the action desired and press; follow any on-screen prompts to complete the action. (Import function from this screen is ONLY used to upload a menu file from another cabinet, NOT to upload a file from the MenuConnect online menu creation application). To upload a MenuConnect created menu file, please use the USB icon from the Home screen.



- Export Menu Files - Exports menu files. Remove the USB port cover and the WiFi dongle. Plug a USB drive into the master/external port. Press the Check Flash Drive button. Press the Export Menu Files button. Restart unit.
- Import Menu Files - Imports a menu file from another cabinet. Remove the USB port cover and the WiFi dongle. Plug a USB drive with exported menu files into the master/external port. Press the Check Flash Drive button. Press the Import Menu Files button.
- Export Screen-shots - Not available.
- Export WiFi Logs- Not available.
- Export Kernel Log - Remove the USB port cover and the WiFi dongle. Plug a USB drive into the master/external port. Press the Check Flash Drive button. Press the Export Kernel Log button. Restart unit.
- Export Error Log - Remove the USB port cover and the WiFi dongle. Plug a USB drive into the master/external port. Press the Check Flash Drive button. Press the Export Error Log button. Restart unit.
- Export Holding Log - Remove the USB port cover and the WiFi dongle. Plug a USB drive into the

master/external port. Press the Check Flash Drive button. Press the Export Error Log button. Restart unit.

LOAD SOFTWARE VIA USB

1. With the cabinet powered up and fully booted up, slide the USB cover open and insert the USB drive in the front of the cabinet.
2. After a few minutes the software update will start.

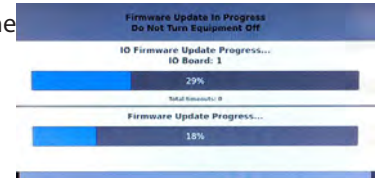

3. When the software update is complete the controller displays Software update successful.
4. Remove the USB from the front of the cabinet.
5. Power cycle the entire cabinet.
6. Press the button. Press the button. Swipe two times to the right to **System Information**. Verify the software versions are correct.
7. Press the button.
8. Press the button.

Software update successful.
Unplug USB and reboot the unit

Section 3 Maintenance

⚠ DANGER

All utility connections and fixtures must be maintained in accordance with Local and national codes.

⚠ DANGER

It is the responsibility of the equipment owner to perform a Personal Protective Equipment Hazard Assessment to ensure adequate protection during maintenance procedures.

⚠ DANGER

Failure to disconnect the power at the main power supply disconnect could result in serious injury or death. The power switch DOES NOT disconnect all incoming power.

⚠ DANGER

Disconnect electric power at the main power disconnect for all equipment being serviced. Observe correct polarity of incoming line voltage. Incorrect polarity can lead to erratic operation.

⚠ Warning

When using cleaning fluids or chemicals, rubber gloves and eye protection (and/or face shield) must be worn.

⚠ Caution

Maintenance and servicing work other than cleaning as described in this manual must be done by an authorized service personnel.

Cleaning and Sanitizing Procedures

GENERAL

You are responsible for maintaining the equipment in accordance with the instructions in this manual. Maintenance procedures are not covered by the warranty.

| Maintenance | Daily | After Prolonged Shutdown | At Start-Up |
|-------------------------------------|-------|--------------------------|-------------|
| Exterior | X | X | X |
| Interior | X | X | X |
| Tray, Lid, False Bottom & Tray Seal | X | X | X |
| Plastic Tray | X | X | X |
| RFID Collar | X | X | X |
| RFID Carrier | X | X | X |

EXTERIOR CLEANING

⚠ Warning

Never use a high-pressure water jet for cleaning or hose down or flood interior or exterior of units with water. Do not use power cleaning equipment, steel wool, scrapers or wire brushes on stainless steel or painted surfaces.

⚠ Caution

Never use an acid based cleaning solution on exterior panels! Many food products have an acidic content, which can deteriorate the finish. Be sure to clean the stainless steel surfaces of ALL food products.

The stainless steel outer case requires nothing more than a daily wiping with a damp cloth. If, however, an excessive amount of food particles/grease are allowed to collect, a non-abrasive cleaner (hot sudsy water) may be used. Wipe dry with a clean, soft cloth.

Always rub with the "grain" of the stainless steel to avoid marring the finish. Never use steel wool or abrasive pads for cleaning. Never use chlorinated, citrus based or abrasive cleaners.

Stainless steel exterior panels have a clear coating that is stain resistant and easy to clean. Products containing abrasives will damage the coating and scratch the panels. Daily cleaning may be followed by an application of stainless steel cleaner which will eliminate water spotting and fingerprints. Early signs of stainless steel breakdown are small pits and cracks. If this has begun, clean thoroughly and start to apply stainless steel cleaners in attempt to restore the steel.

INTERIOR CLEANING**⚠ Caution**

Do not use caustic cleaners on any part of the holding cabinet or holding cabinet cavity. Use mild, non abrasive soaps or detergents, applied with a sponge or soft cloth. Never use sharp implements or harsh abrasives on any part of the holding cabinet.

The product tray, product RFID collar, lid, false bottom and tray seal may be cleaned via dishwasher or with warm soapy water. Care must be taken to prevent water or cleaning compounds from getting on internal parts, especially the switches on the control panel.

PLASTIC TRAY CLEANING**⚠ Caution**

Environmental stress cracking can occur, proper dilution and rinsing per detergent manufacturers' directions are mandatory.

Food-approved detergents can be used if they are diluted per manufacturers' directions and adequately rinsed away prior to high temp drying cycle. Basic alcohols such as isopropyl are acceptable for hard-to-remove stains. Otherwise, do not use organic solvents.

DAILY CLEANING INSTRUCTIONS

1. You will need a damp cloth and hot soapy water.
2. Turn the unit off.



3. Unplug the unit.



4. Allow unit to cool for approximately 30 minutes. If it is necessary to continue before it has completely cooled wear heat resistant gloves.
5. Remove the trays. Remove product RFID collars from each tray.

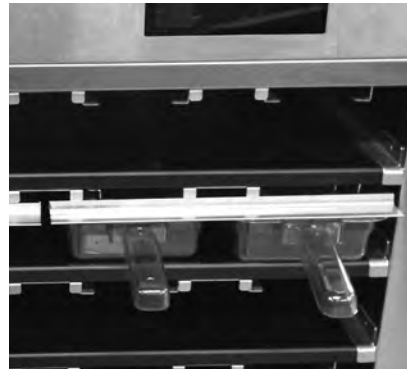

- 6. Remove the tray seals.

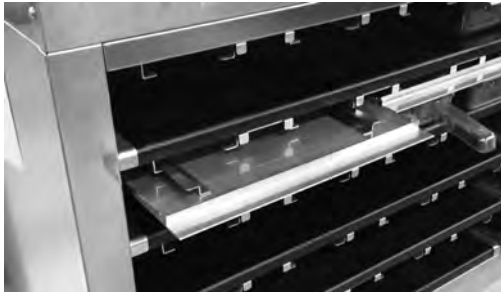

- 7. Clean the trays, product RFID collars, lids, false bottoms and tray seals in a dishwasher or with warm soapy water.



- 8. With a damp cloth wipe the touch screens and around the power switch. Be careful not splash water or cleaning compounds around electrical parts.
- 9. Wipe the stainless steel exterior with a damp cloth, rubbing with the grain of the steel. If an excessive amount of food particles/grease has collected, hot sudsy water (non-abrasive) may be used.



- 10. Wipe the interior with a damp cloth; clean from the front and the back to reach all surfaces. Pay attention to the ledges that support tray seals. If an excessive amount of food particles/grease has collected, hot sudsy water (non-abrasive) may be used.



- 11. Allow holding cabinet, trays, product RFID collars and tray seals to dry.
- 12. Reinstall the cleaned tray seals.



- 13. Install the collars on the clean trays by attaching the two collar halves together around the tray until they click.
- 14. Reinstall the cleaned trays.
- 15. Plug the unit in.



Component Identification

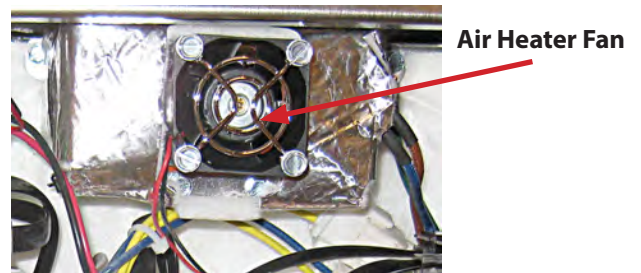
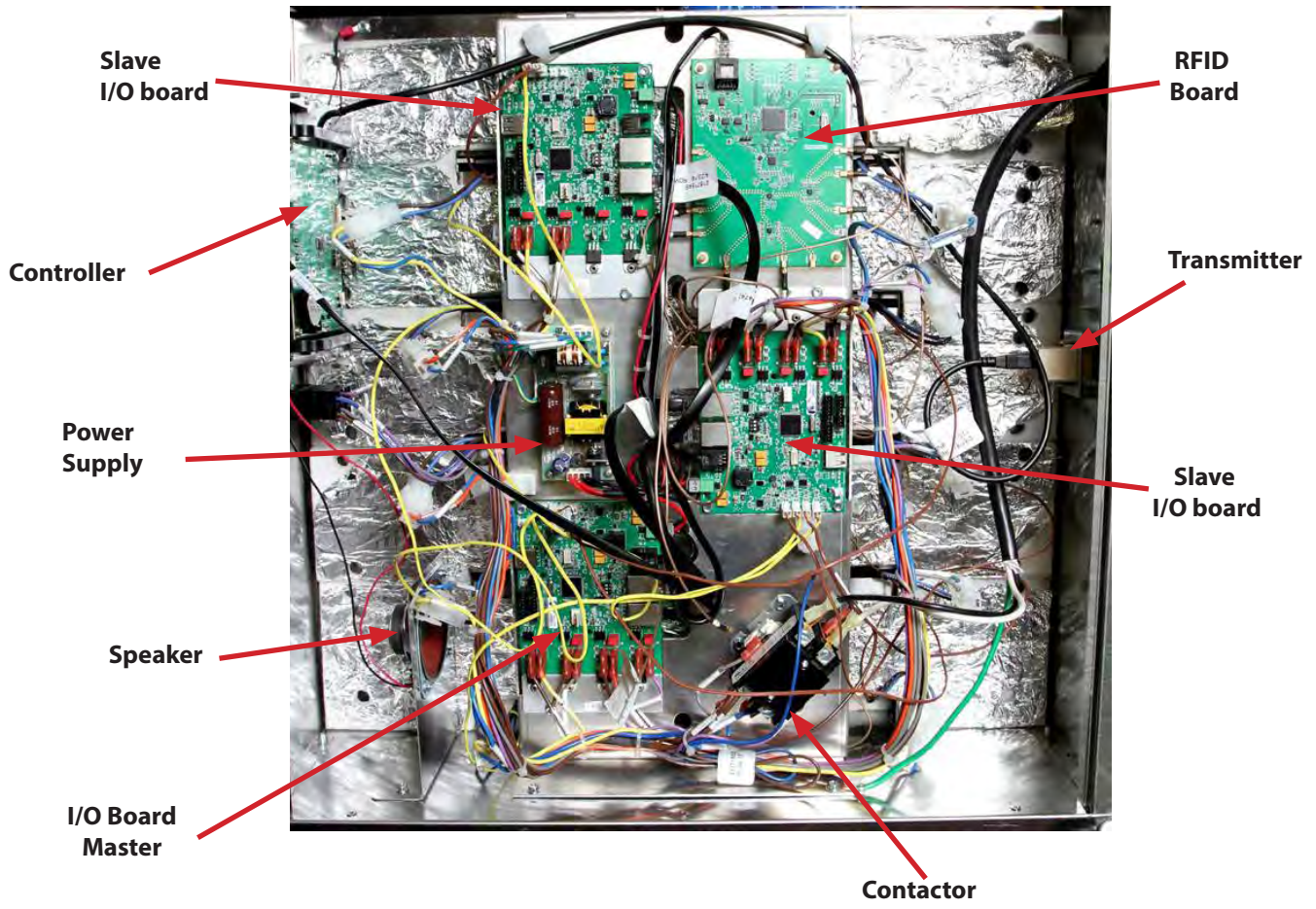

INSTRUCTIONS FOR REPLACING A HEATER PAD

Pad heater probes are located in the heater pad assembly.

NOTE : Failed thermocouples require a heater pad replacement.

1. Remove air diffusers above pad heater by raising the locking clips and sliding the diffusers out of the cabinet.
2. Remove the end panels by sliding up and away from the cabinet.
3. From each side remove nuts attached to the studs of both end clips.



4. Remove the the bracket holding the antenna by removing the nuts on the back.



5. From each side remove hex shoulder screw and standard screws holding aluminum heater plate above zone.



6. Thermocouple connections are at the top of the IO board. Mark plugs for reassembly. Pay close attention to their placement. From both sides of the cabinet unplug heaters and probes associated with aluminum plate above zone.



7. Raise heater plate and slide out the insulation under the plate to gain access to heater pad.



8. Route the power coupling through the cabinet interior.

9. Pull the heater plate out carefully.



10. Flip the aluminum plate over. Peel the old heater pad off and attach the new one.

11. Reverse the steps to reassemble the cabinet.



INSTRUCTIONS FOR REPLACING A TOUCH SCREEN

1. Remove the top and right side of the cabinet.
2. Disconnect any cables or wires from the rear of the touch screen, marking their position for reassembly
3. Remove and replace the faulty touch screen.
4. Remove the SD card from the failed controller by gently pushing in on the SD card and releasing until it is SD card is ejected. The SD card is held in by a spring lock (
5. If the new controller has an SD card in place, remove it and insert the SD card removed from the failed controller in previous step and insert with contact down towards the board. Gently push the SD card into the SD card slot until it locks in place.
6. Reattach any cables or wires and attach the top and sides of the cabinet.
7. Perform a setup under Utilities>System Information using code 159357. Enter the serial, model and store number into the controller. Some models may require a setup for the touch screens. If required select orientation, model number, front or back location.

INSTRUCTIONS FOR REPLACING AN IO BOARD

1. Disconnect power.
2. Remove the side of the cabinet associated with the IO board that needs replaced.
3. Mark wires and harnesses locations for easy reassembly.
4. Disconnect wires and harnesses.
5. Remove the existing IO board.
6. Service boards come with the DIP switch and jumper set to default positions. They must be repositioned to reflect the board being replaced. Reposition the settings on new IO board on J5 and SW 1 the same as the removed IO board (see illustrations to the right and below and the on the following page).
7. Carefully reattach all wires and harnesses.
8. Replace the cabinet side and reconnect to power to return to service.

I/O Board Switch and Jumper Settings

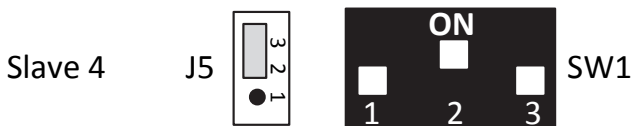
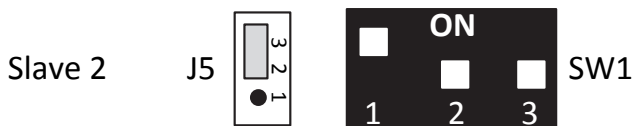
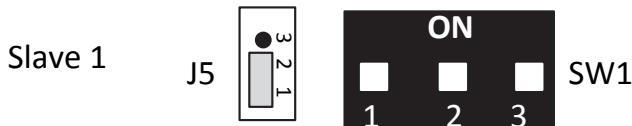
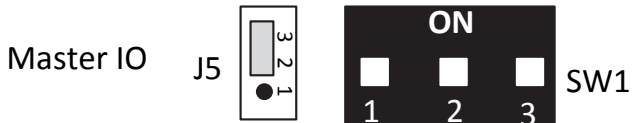

⚠ Caution

Ensure SW1 dip switches and J5 jumper match the old I/O Board upon replacement. When the jumper is in the wrong position, zones will not display when checking temperature.

SW1 and J5 settings together define the system address.

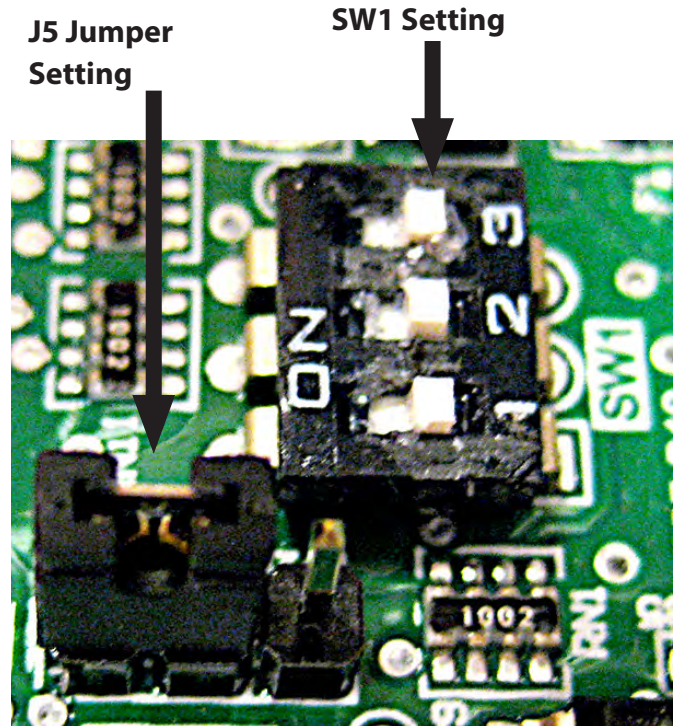

RFID READER BOARD

Some cabinets have RFID tray tracking. RFID antenna boards connect slot-mounted RFID antennas to cabinet-content monitoring system. RFID tags in the trays activate the system.

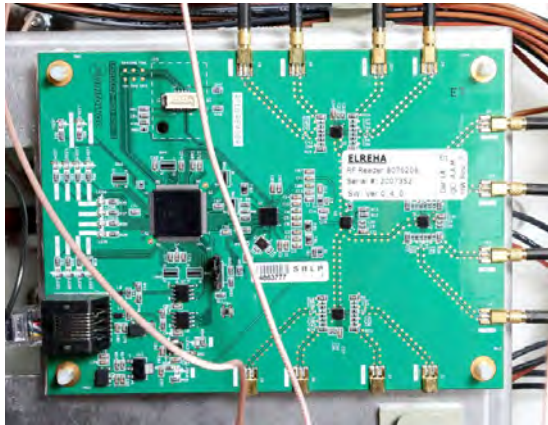

RFID Reader Board

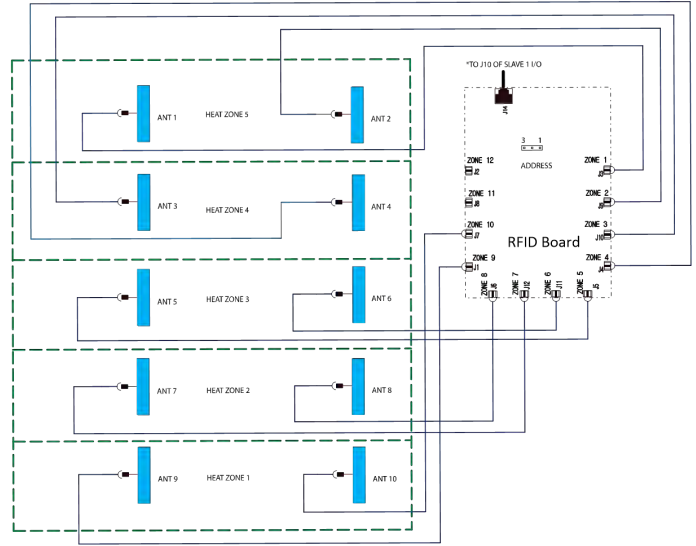

Typical RFID antenna arrangement

The cabinet communicates with the store's wireless system with a "dongle" that's under a cover on the cabinet's exterior.



RFID Antenna



Dongle (RFID Transmitter)



RFID Transmitter Cover

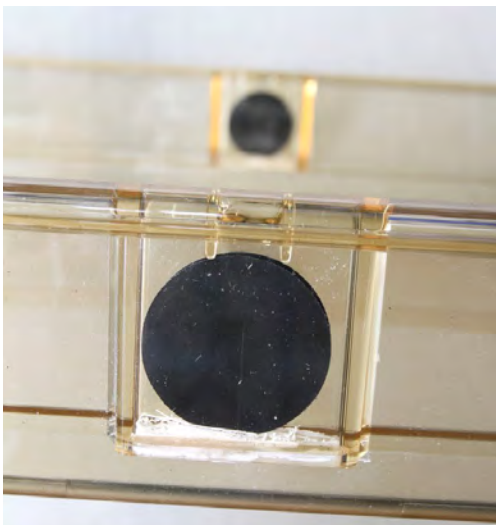

Tray with RFID tag

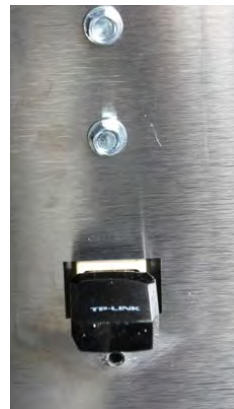

USB port-mounted Dongle (RFID Transmitter)

I/O Board

⚠ Caution

I/O Board must be loaded with software. A blue colored sticker will indicate when software is loaded and the color and part number to indicate software version.

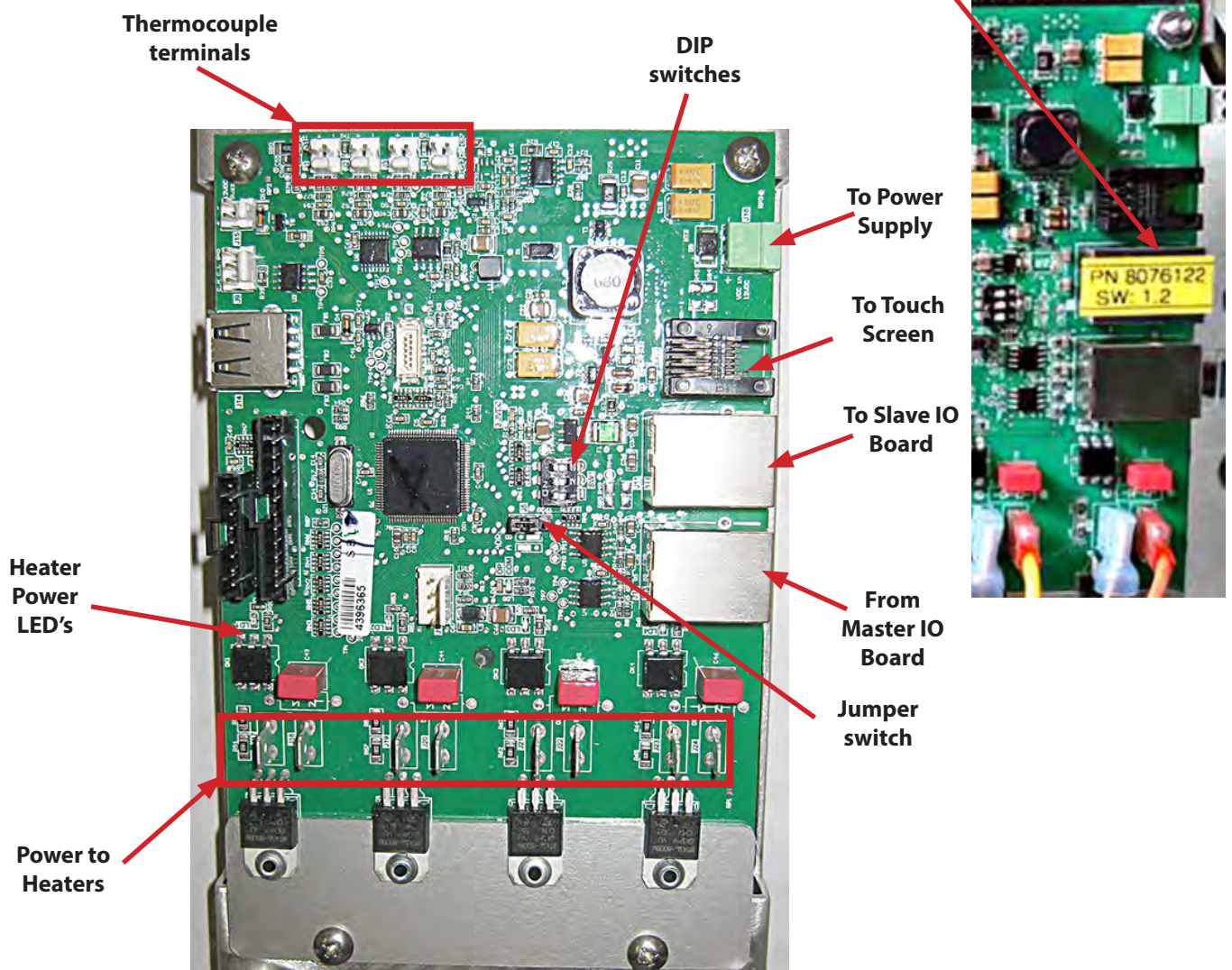

Thermocouples monitors zones of the cabinet. In the illustration below the master IO board, monitors zones 2, 4, right side slots.

THERMOCOUPLE CONNECTIONS ON MASTER IO BOARD

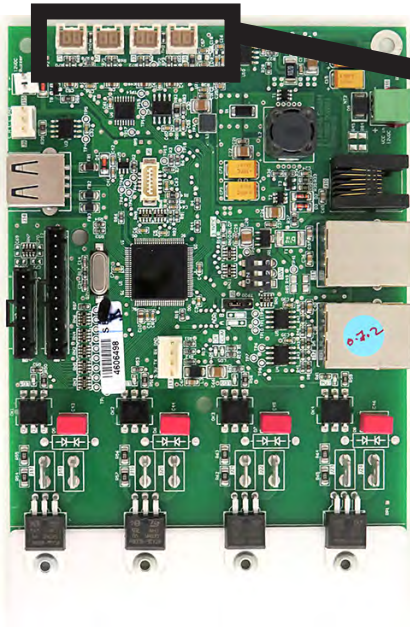

**Heater Zone 2
Front/ Left**

**Heater, Zone 2
Rear/Right**

**Heater, Zone 4
Front/ Left**

**Heater, Zone 4
Rear/Right**

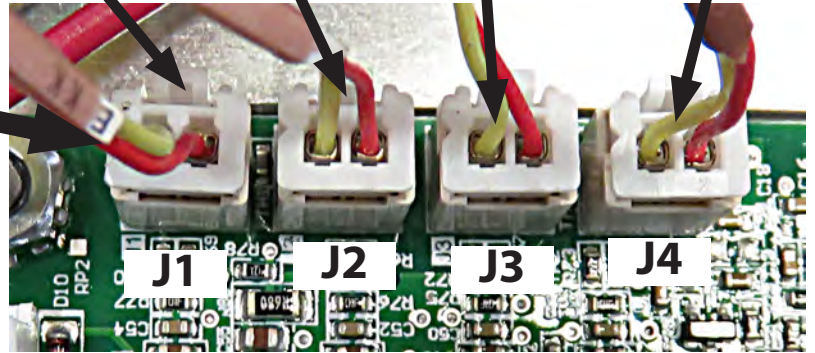

THERMOCOUPLE CONNECTIONS ON SLAVE 1 IO BOARD

The slave 1 board monitors zones 1,3, the left side slots.



**Heater Zone 1
Front/ Left**

**Heater, Zone 1
Rear/Right**

**Heater, Zone3
Front/ Left**

**Heater, Zone 3
Rear/Right**

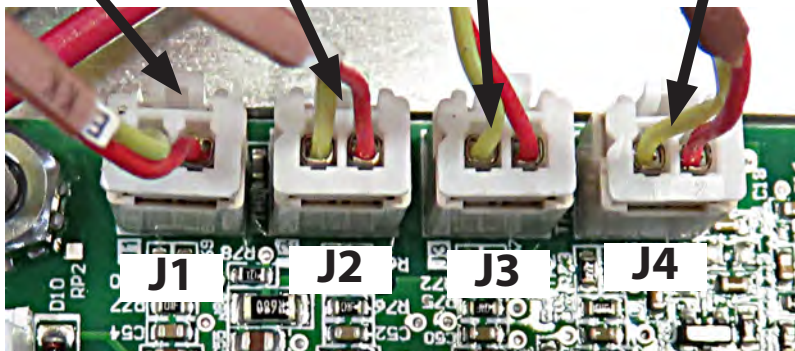

Section 4 Troubleshooting

The software shall track the state of each thermocouple and the state of the thermocouple reading compared to the set point. If the software finds an error, it will begin to time it. When the timer reaches 15 minutes, an error code(s) will display (flash) on the screen. This shall continue indefinitely until the zone is +/- 5 degrees of the set point or the unit is power cycled off and the 15 minute time starts again. If an error is still present, it will be displayed until corrected.

Zone Diagnostics

Zone Diagnostics can show temperatures and issues

1. Ensure the cabinet is powered on, fully booted up and the main screen is displayed (see Figure 1).
2. Press the tools icon (gear) from the home screen (see Figure 2).
3. On the next screen press the row of dots at the bottom of the screen (see Figure 3).
4. The tools options menu is displayed. Press the Zone Diagnostics button (see Figure 4).
5. After the unit has been running for about 15 minutes the temperatures should cycle from hot (RED) to normal (GREEN) to cool (BLUE). Any temperature errors are displayed with "+++" on the affected zone (see Figure 5).
6. Press the "return" arrow to return to the home screen (see Figure 6).
7. Press the Press & Go button to view the products (see Figure 1).



Figure 1

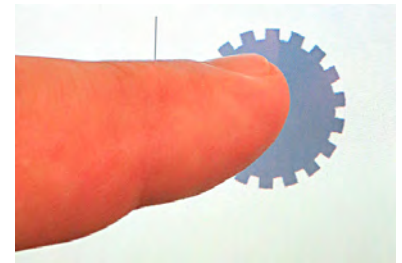

Figure 2



Figure 3

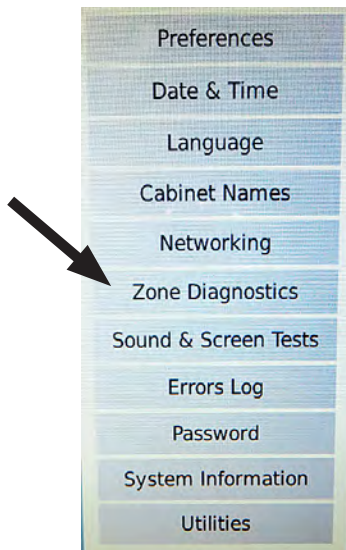

Figure 4

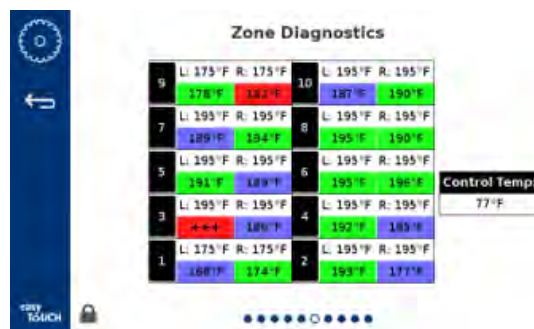
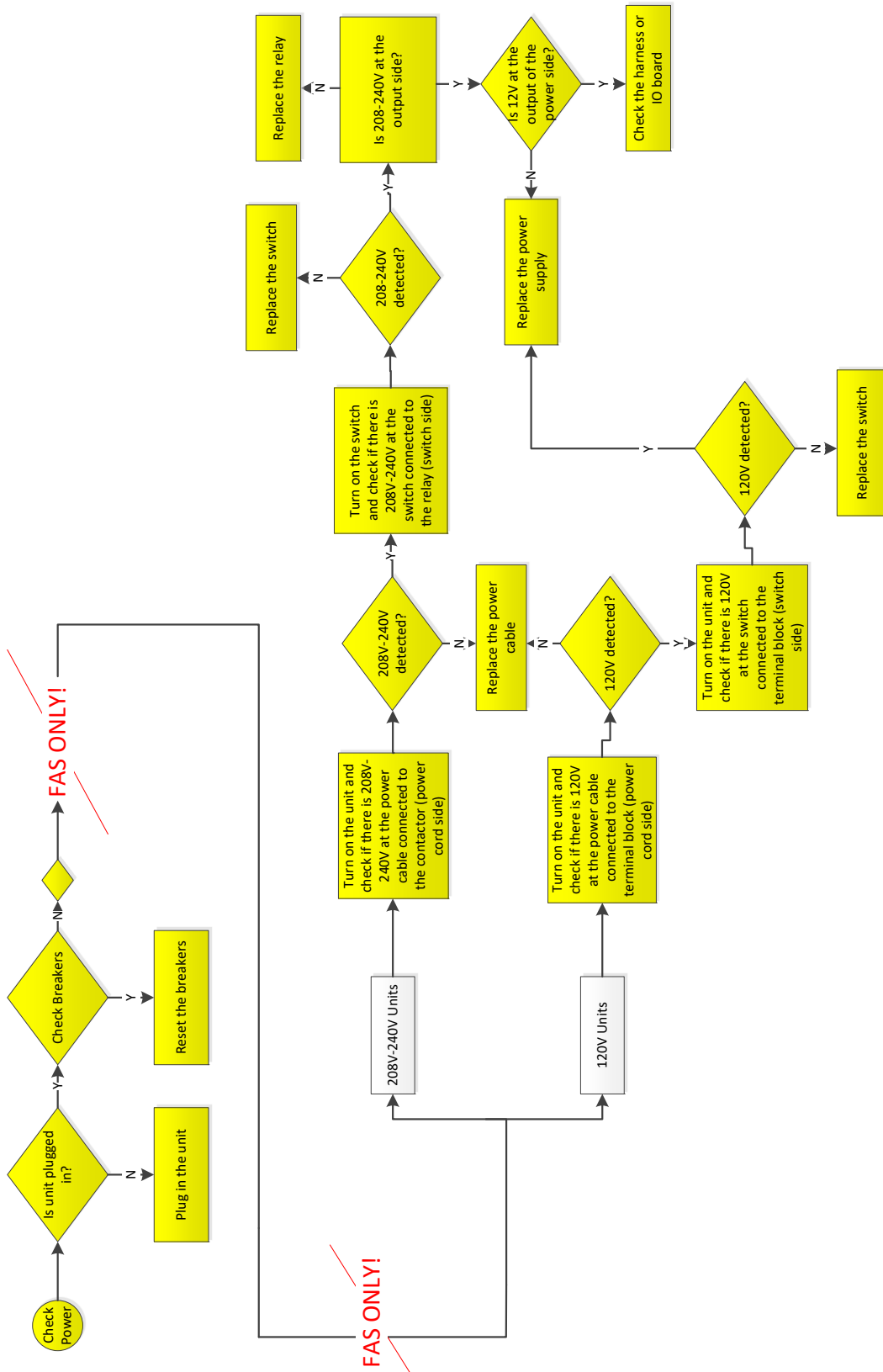
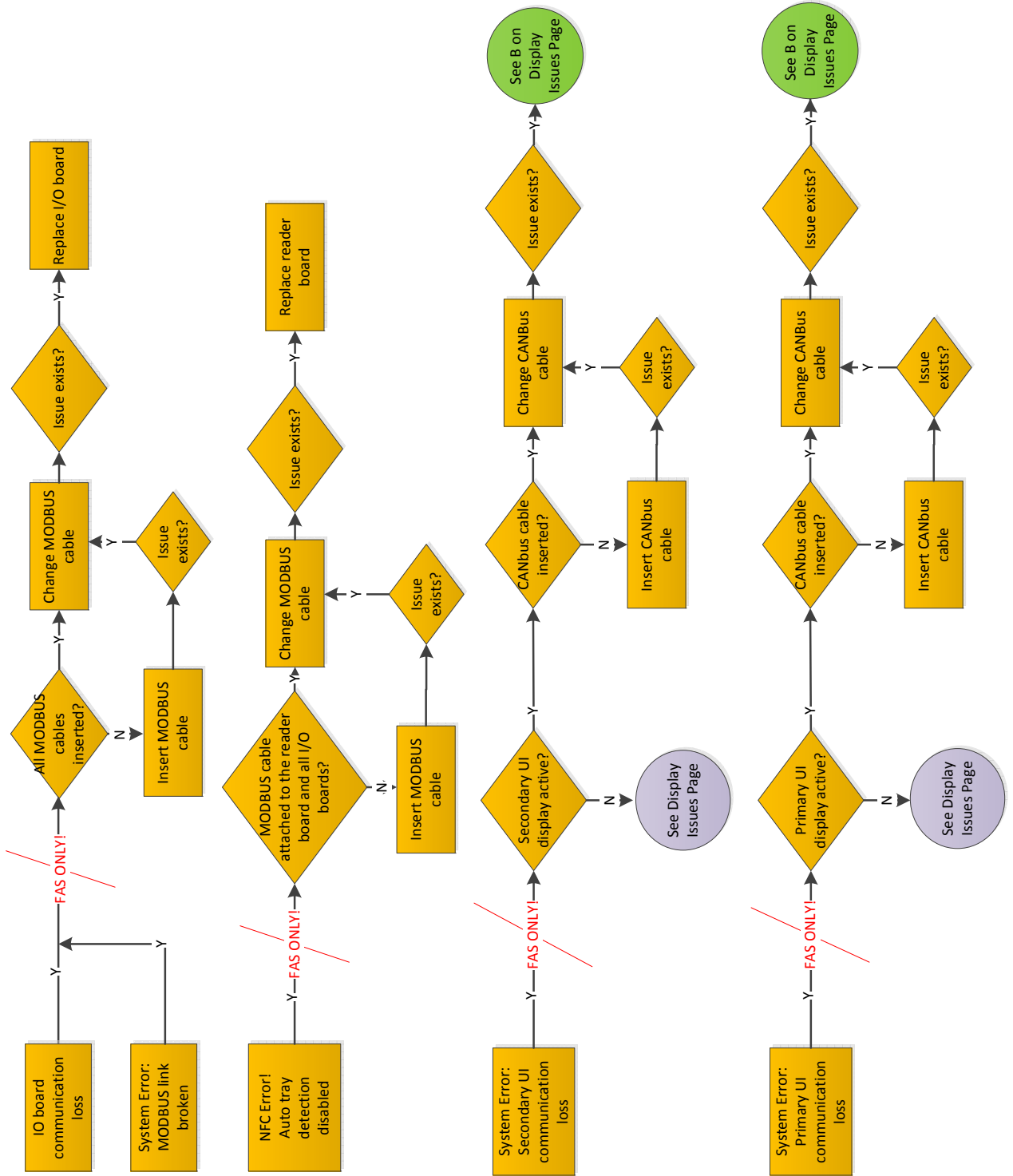

Figure 5

Power Issues Troubleshooting



Communication Issues Troubleshooting



Temperature Too Low/Shelf Temp Low Issues Troubleshooting

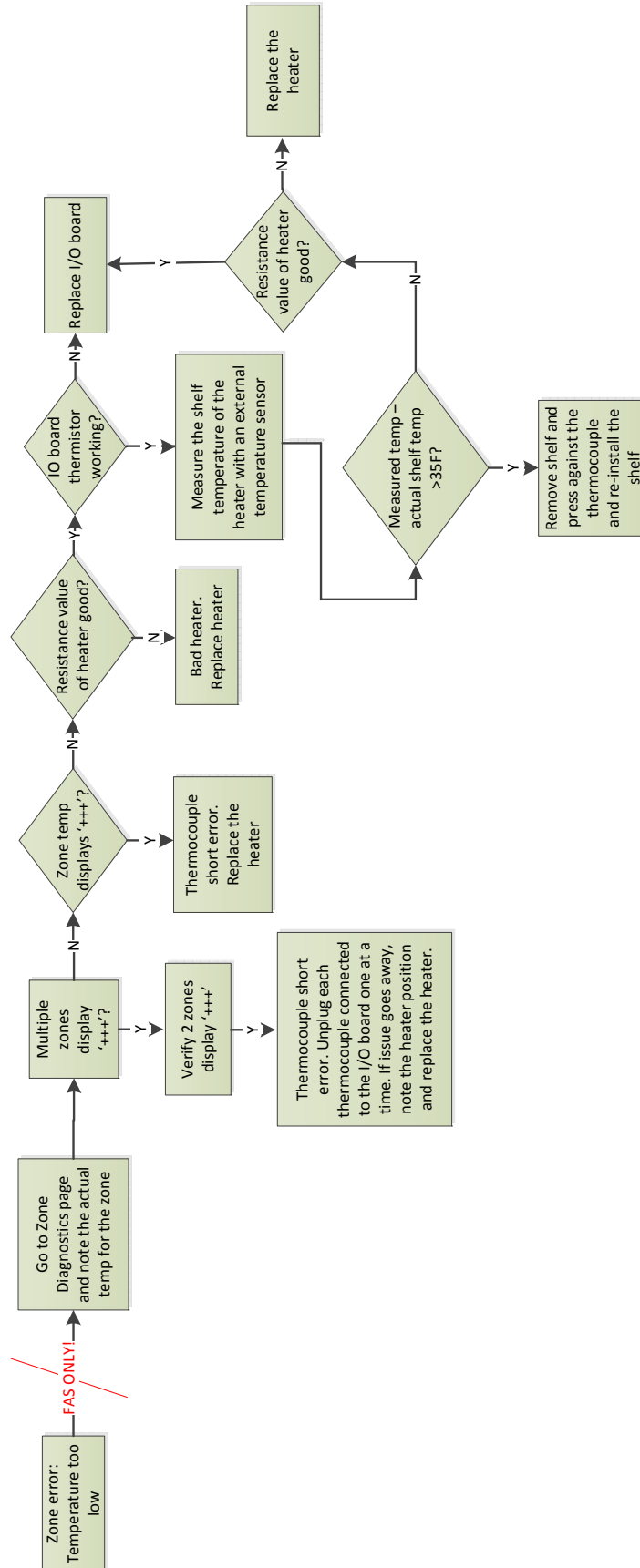

Temperature Too High Issues Troubleshooting

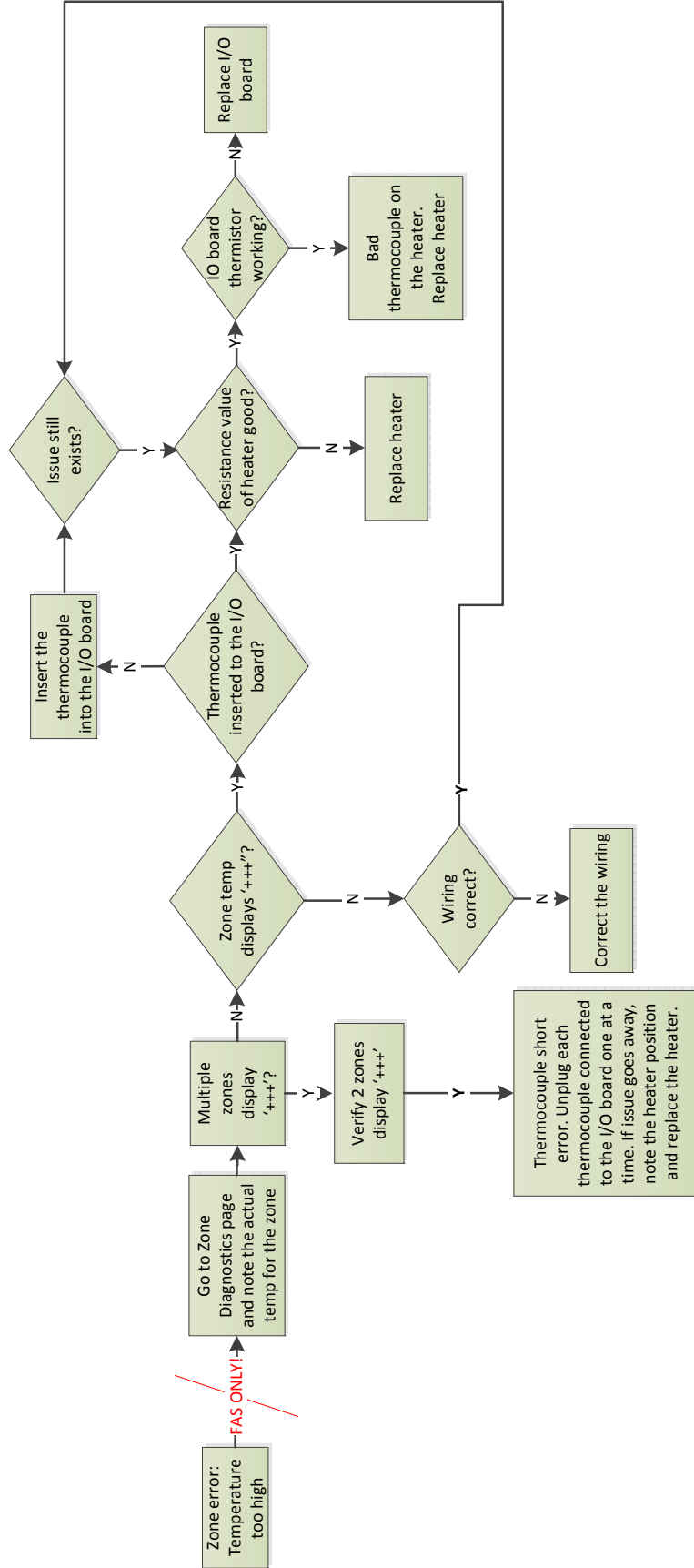

Display Issues Troubleshooting

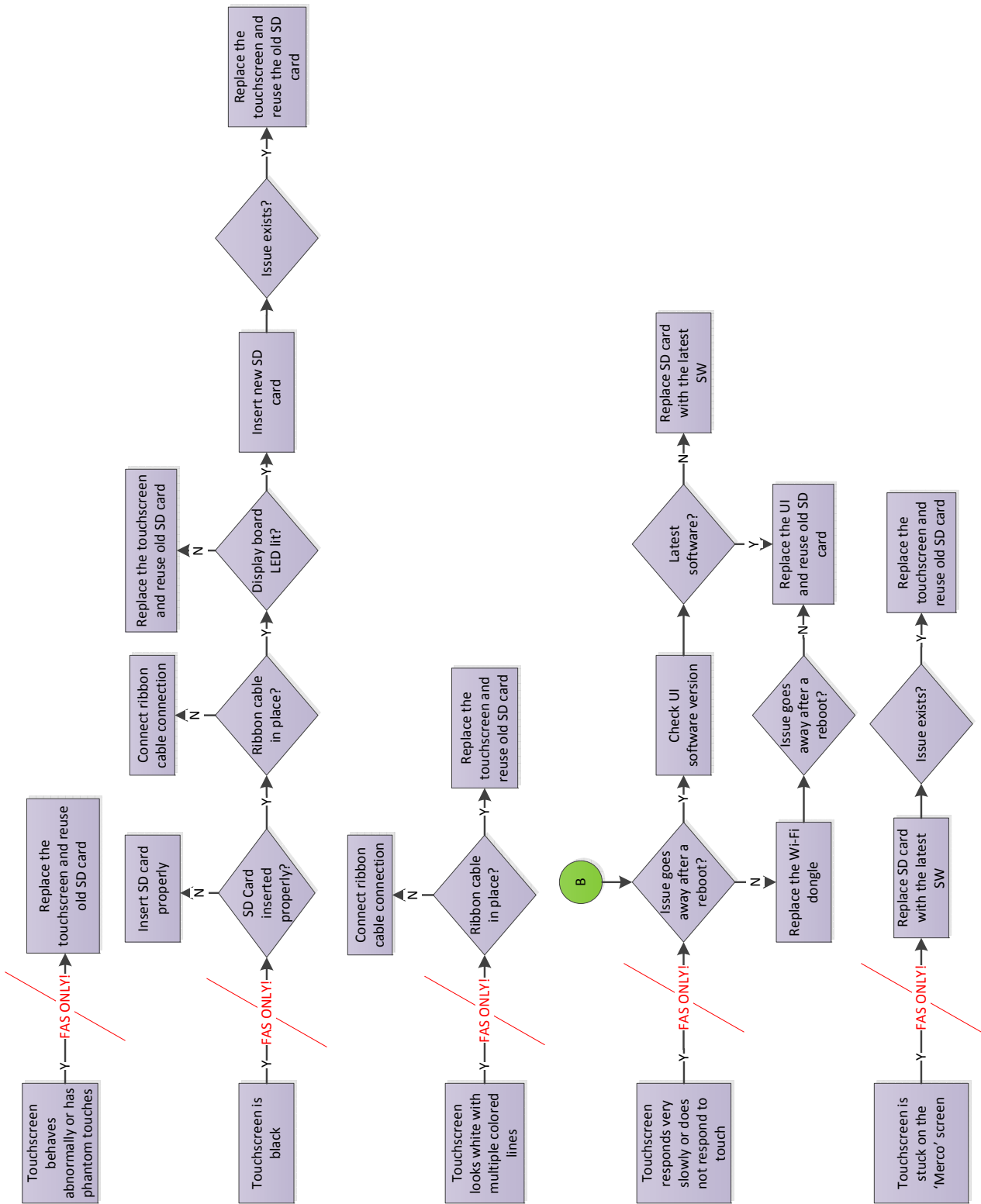

Product Mismatch/Pan Sensing Issues Troubleshooting

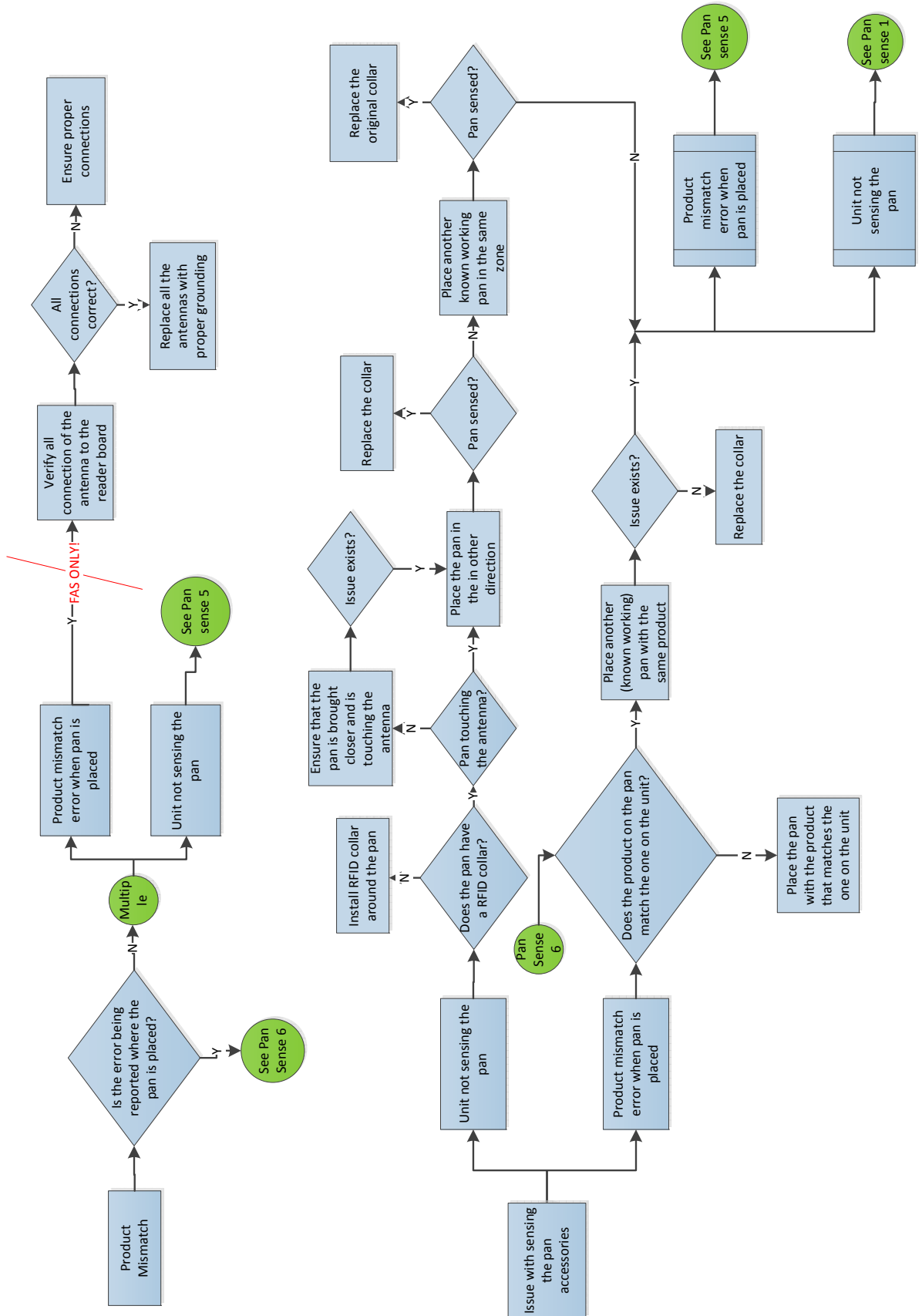

Product Mismatch/Pan Sensing Issues Troubleshooting cont.

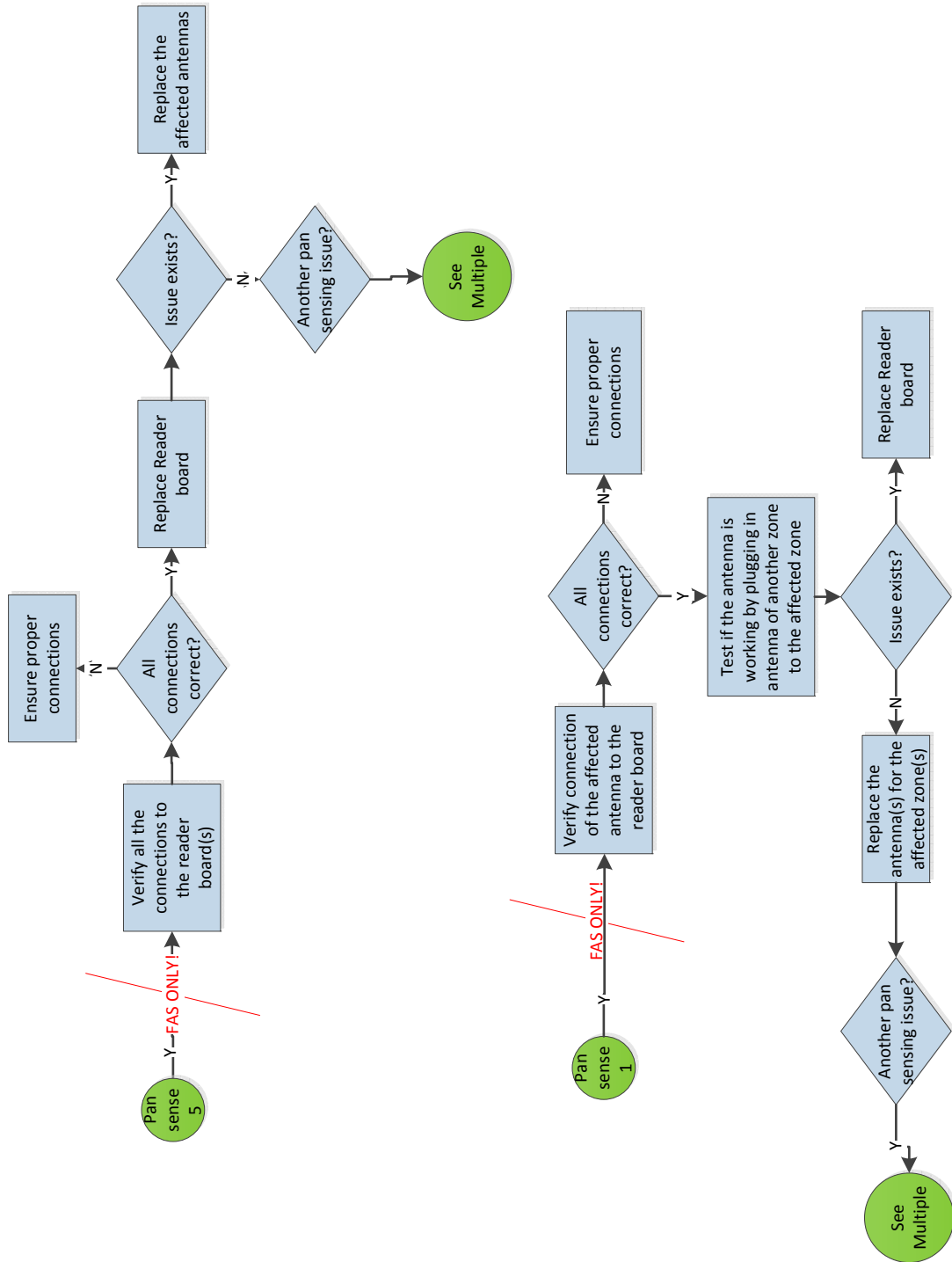

Network and ID Connector Issues Troubleshooting

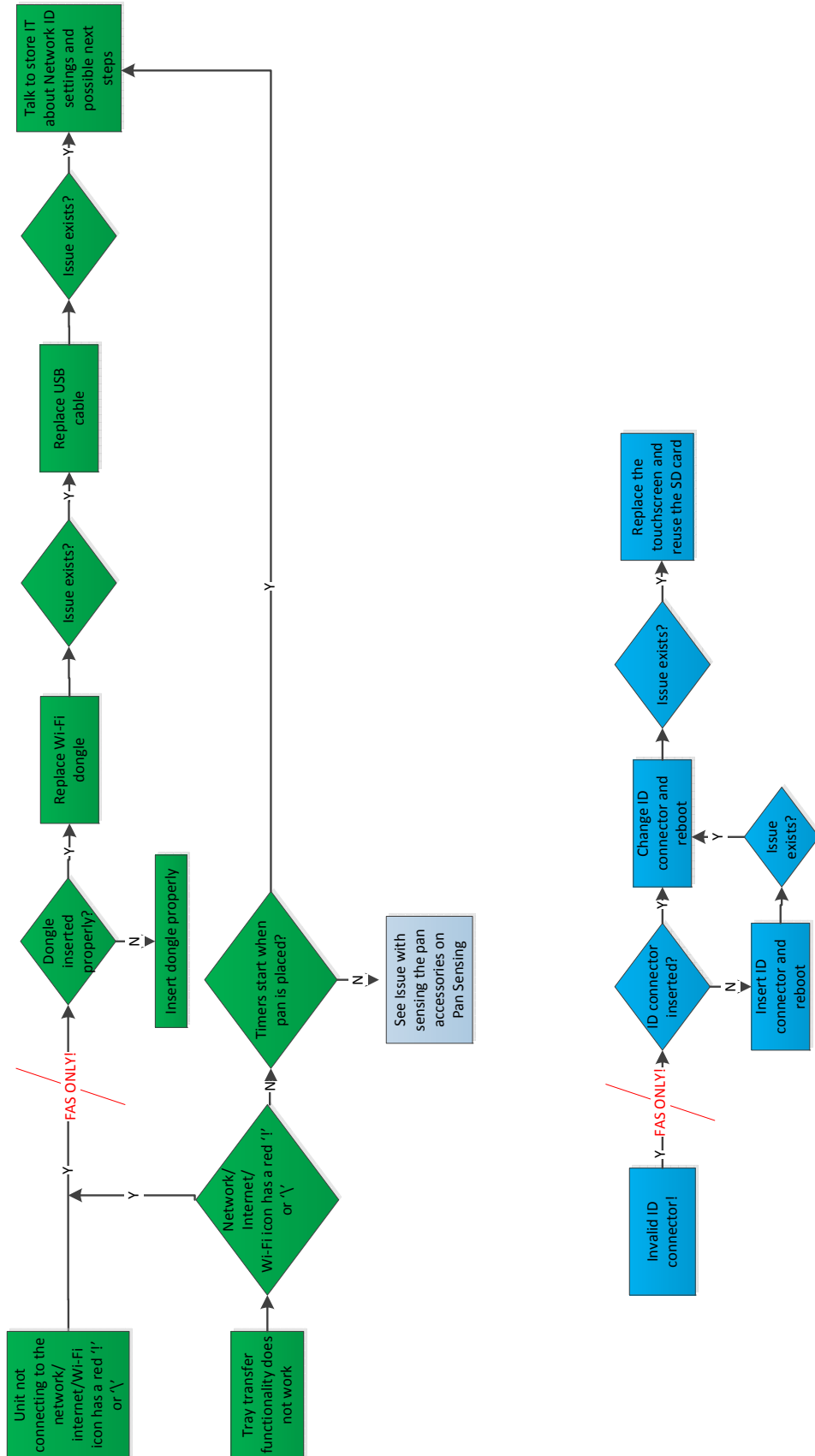

Heater/Thermocouple Troubleshooting

Thermocouple Reading is Below or Above Set Point - Zone Error is displayed on screen

1. Document all temperature readings for unit, each zone, upper and lower.
2. If the zone probes are switched, there will be two errors, one high and one low.
3. Check the I/O boards where the probes with errors plug in. Check that the probes alternate (yellow brown yellow brown) and are plugged in properly.
4. Heater outputs could be swapped, there will be two errors.
5. The I/O board triac could be shorted or open. An orange LED is associated with each triac, it signals if the triac should be on or off.
6. Isolate each triac wire and check the amperage.
 - If the triac is supposed to be open and there is no current, the problem could be a heater. Check continuity through heating element.
 - If the triac light does not match the amperage, the triac is failing and the I/O board needs to be replaced.
 - Check input and output of triac, this could signal an I/O board failure.



The heater thermocouple (brown wire) is under the same tape as the heater. Failed thermocouples require a heater replacement.

Check ohm resistance on heater pad. The ohms and part numbers are below.

- o 8076171 - MHS/MHG 2x2 120V 200W 72Ω (64.8Ω–79.2Ω)
- o 8076098 - MHG 2x3 230V 100W 529Ω (476.1Ω–581.9Ω)
- o 8076099 - MHG 2x3, 3x2, 4x2 230V 200W 264.5Ω (238.05Ω–290.95Ω)
- o 8076237 - MHA 3x2 120V 200W 72Ω (64.8Ω - 79.2Ω)
- o 8076459 - MHD 3x2, 8x2 Lower, 4x2L 230V 200W-176.3Ω (158.7Ω -193.9Ω)
- o 8076461 - MHD 3x2, 8x2 Upper 230V 200W- 176.3Ω (158.7Ω -193.9Ω)

Common Error Messages

- **Heating problem (Zone error - Temperature issues - probes, heater, fans)**



| Cause | Correction |
|---|--|
| Heating pad connectors are loose or defective. | Ensure the heater pad wires are securely connected to the IO board. If so, and heater readings are out of range, replace heater pad. |
| Thermocouple wire connections are loose or defective. | Ensure the thermocouple wires are securely connected to the IO board. If so, and thermocouple readings are out of range, replace heater pad. |
| Heating pad has failed. | Replace heater pad. |
| Shorted thermocouple wire to chassis. | Replace heater pad. |
| Open thermocouple wire. | Replace heater pad. |
| Heating pad I/O circuit board is defective. | Replace I/O board. |

Units with 2 displays (Secondary UI not found) - Problem is likely in the wiring harness connecting the two UI's.

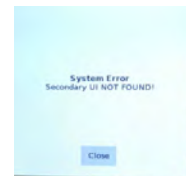

NFC Error - RFID function disabled.

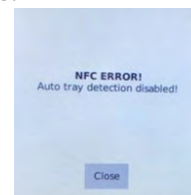

Section 5 Wiring Diagrams

MHG - 2x2 Wiring

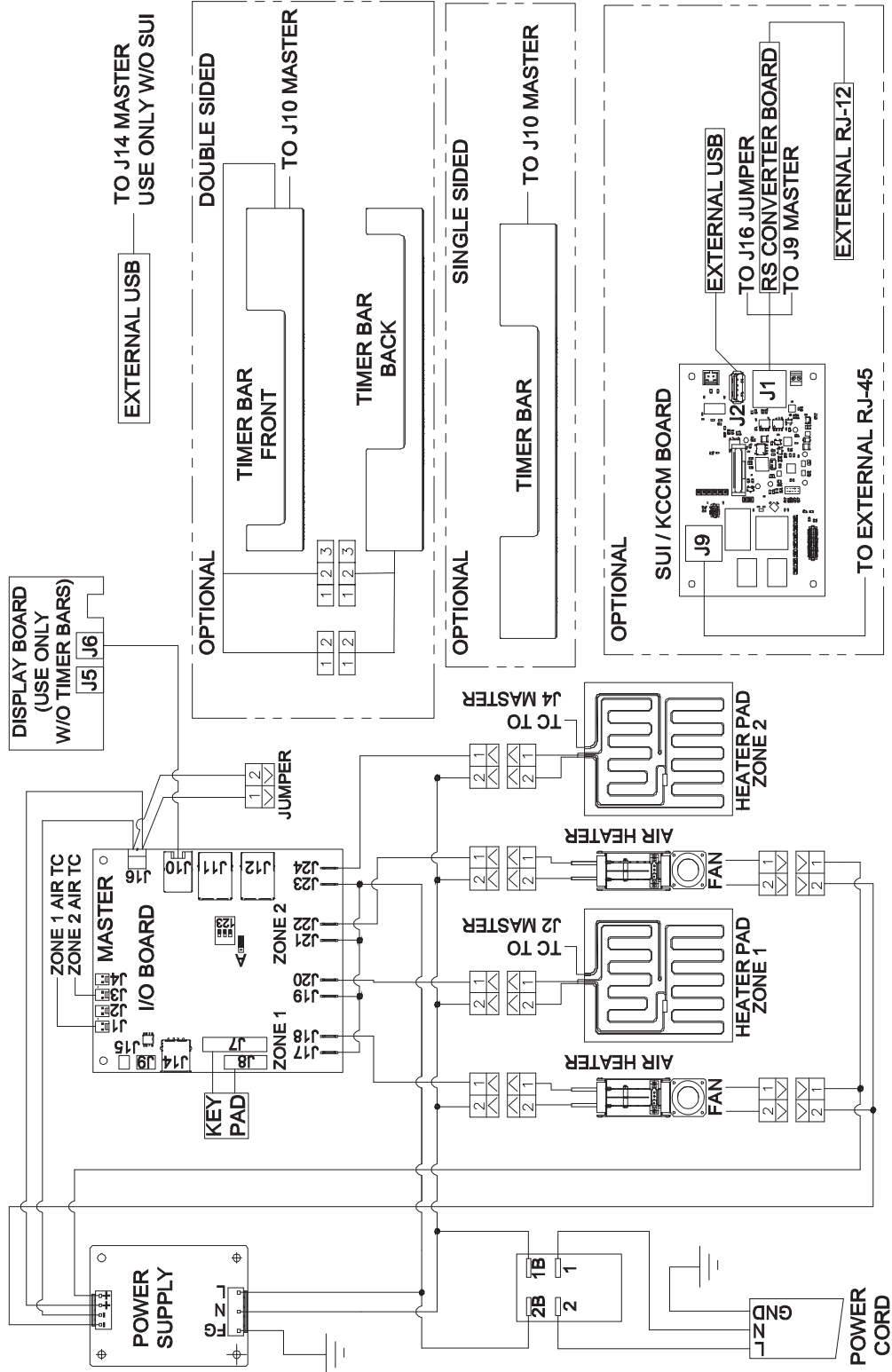

8052099C

MHS - 2x2 Wiring

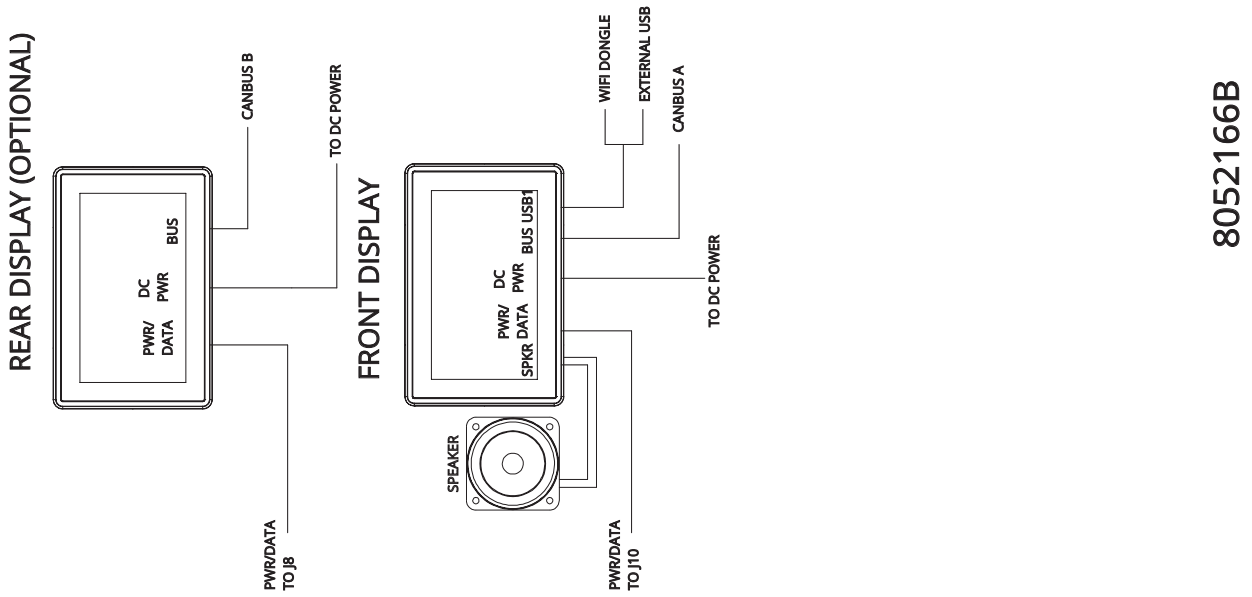

8052166B

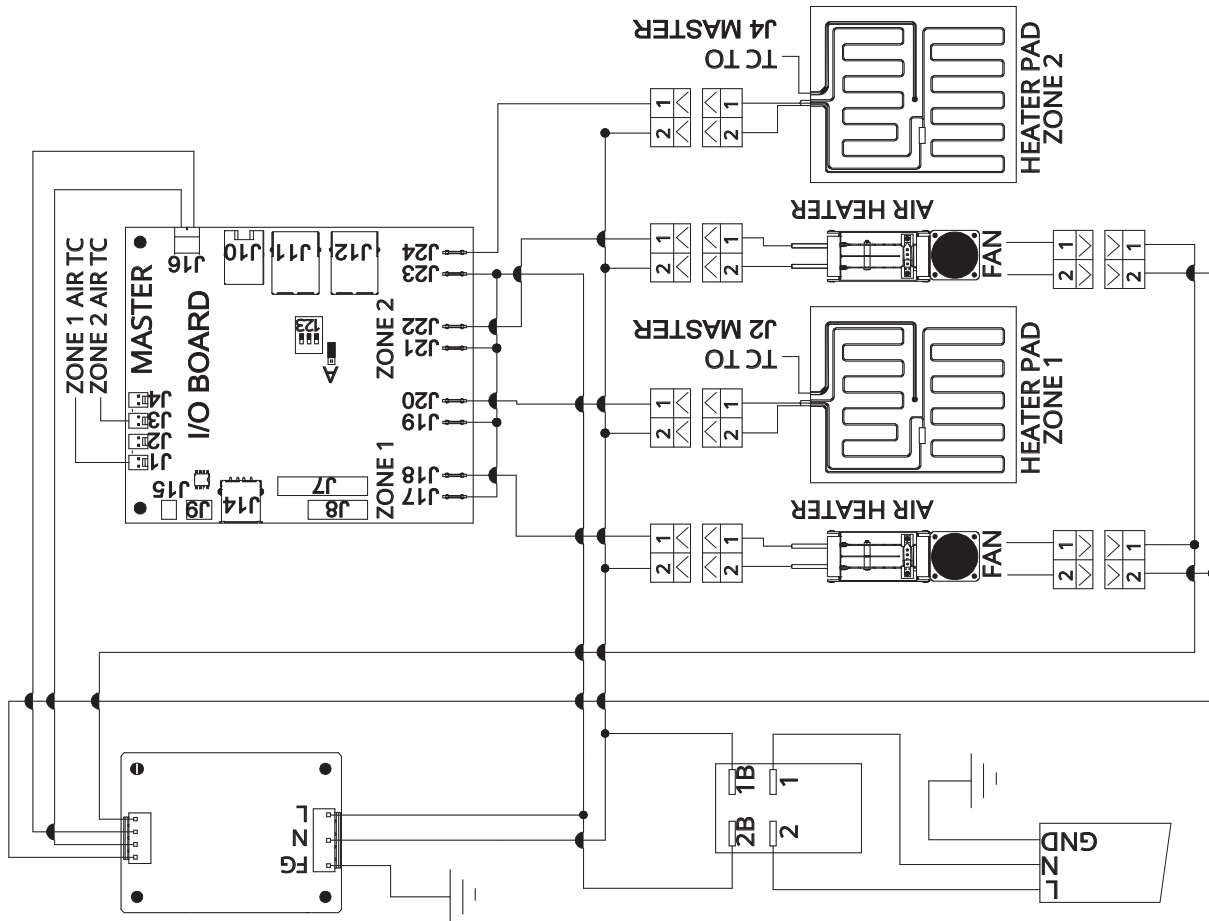

MHG - 2x3 Wiring

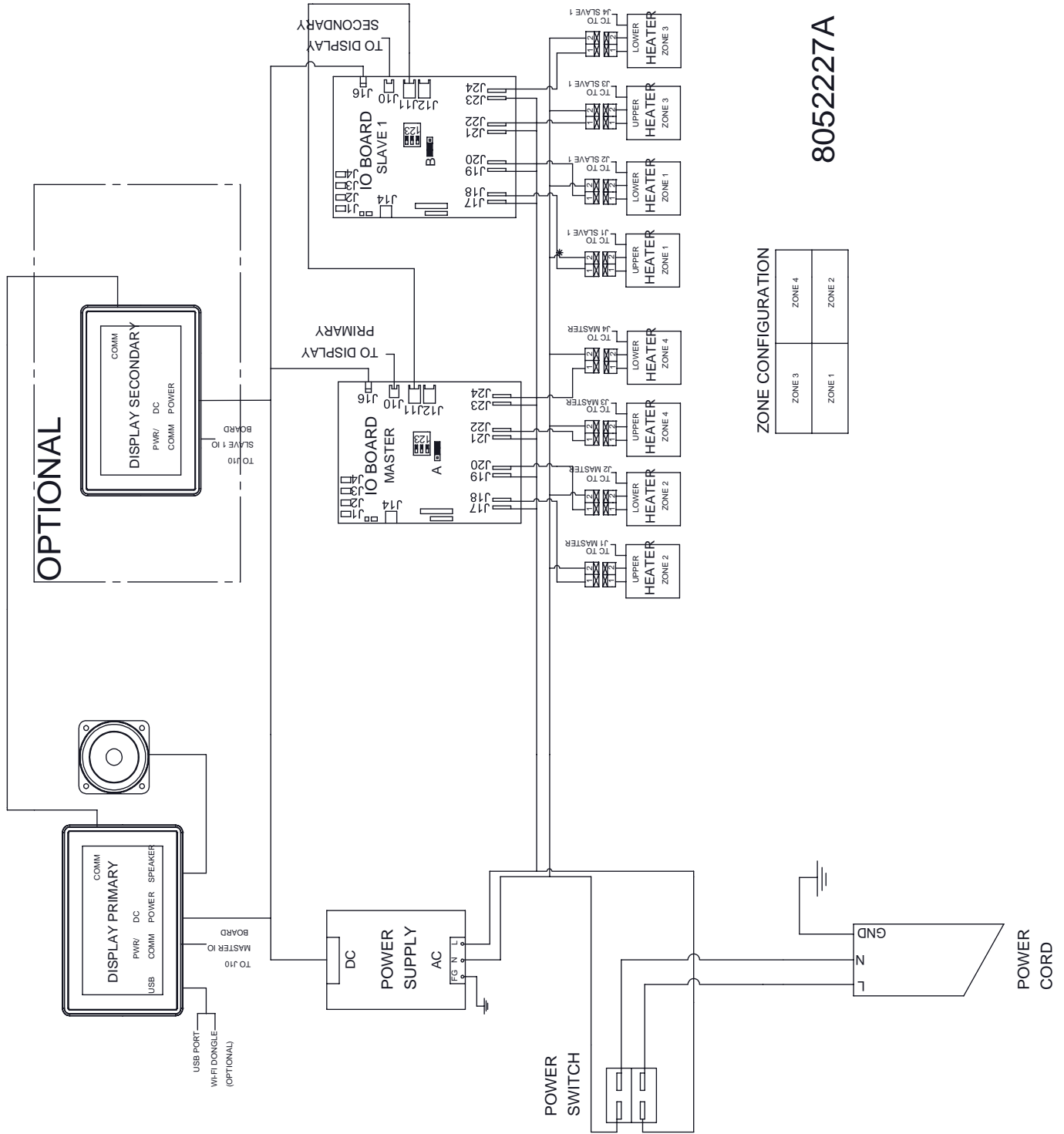

MHA/MHD - 3x2 Wiring

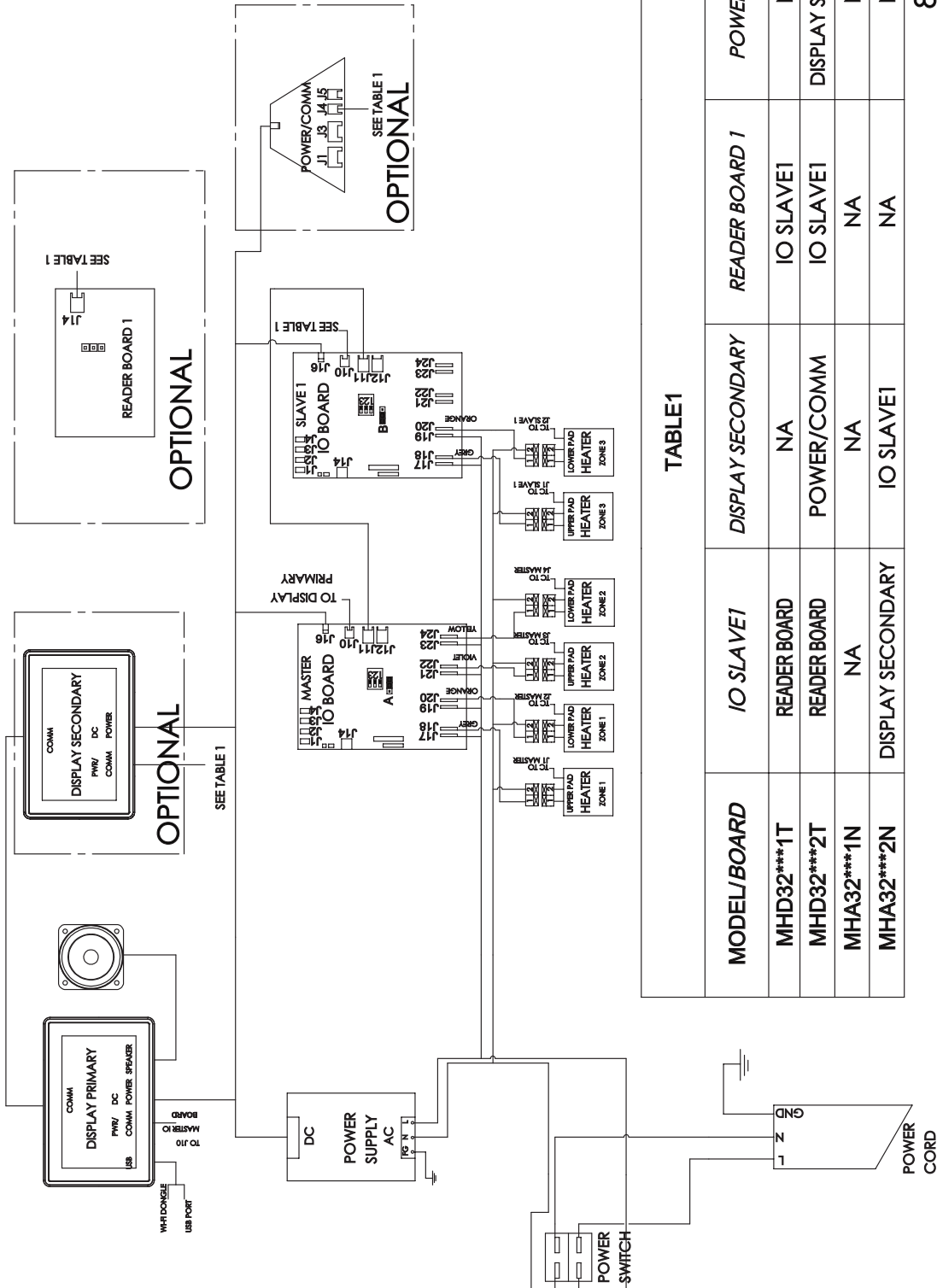
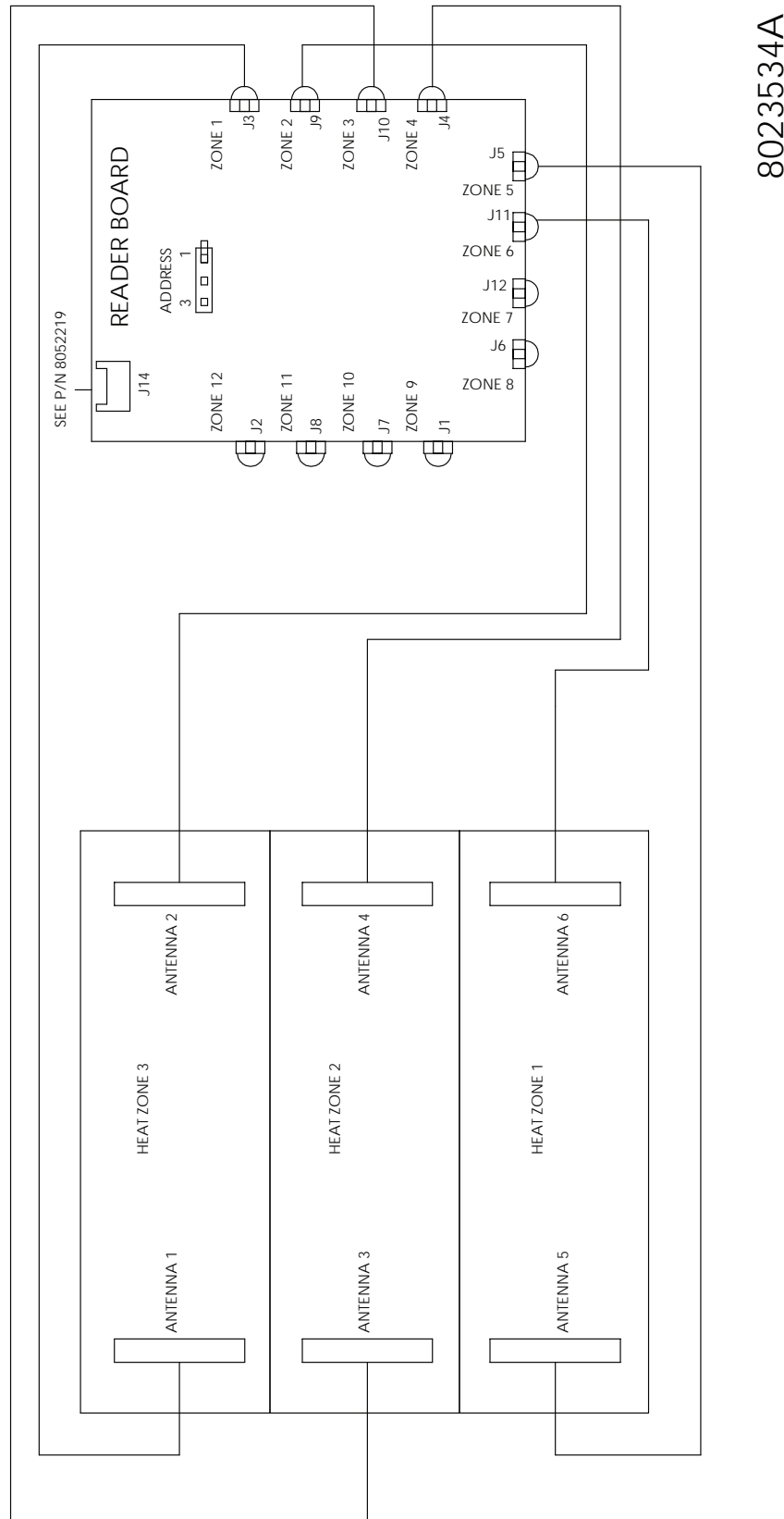

TABLE 1

| MODEL/BOARD | IO SLAVE1 | DISPLAY SECONDARY | READER BOARD 1 | POWER/COMM |
|-------------|-------------------|-------------------|----------------|-------------------|
| MHD32***1T | READER BOARD | NA | IO SLAVE1 | NA |
| MHD32***2T | READER BOARD | POWER/COMM | IO SLAVE1 | DISPLAY SECONDARY |
| MHA32***1N | NA | NA | NA | NA |
| MHA32***2N | DISPLAY SECONDARY | IO SLAVE1 | NA | NA |

8052219A

MHD - 3x2 RFID Wiring



MHG - 3x2 Wiring

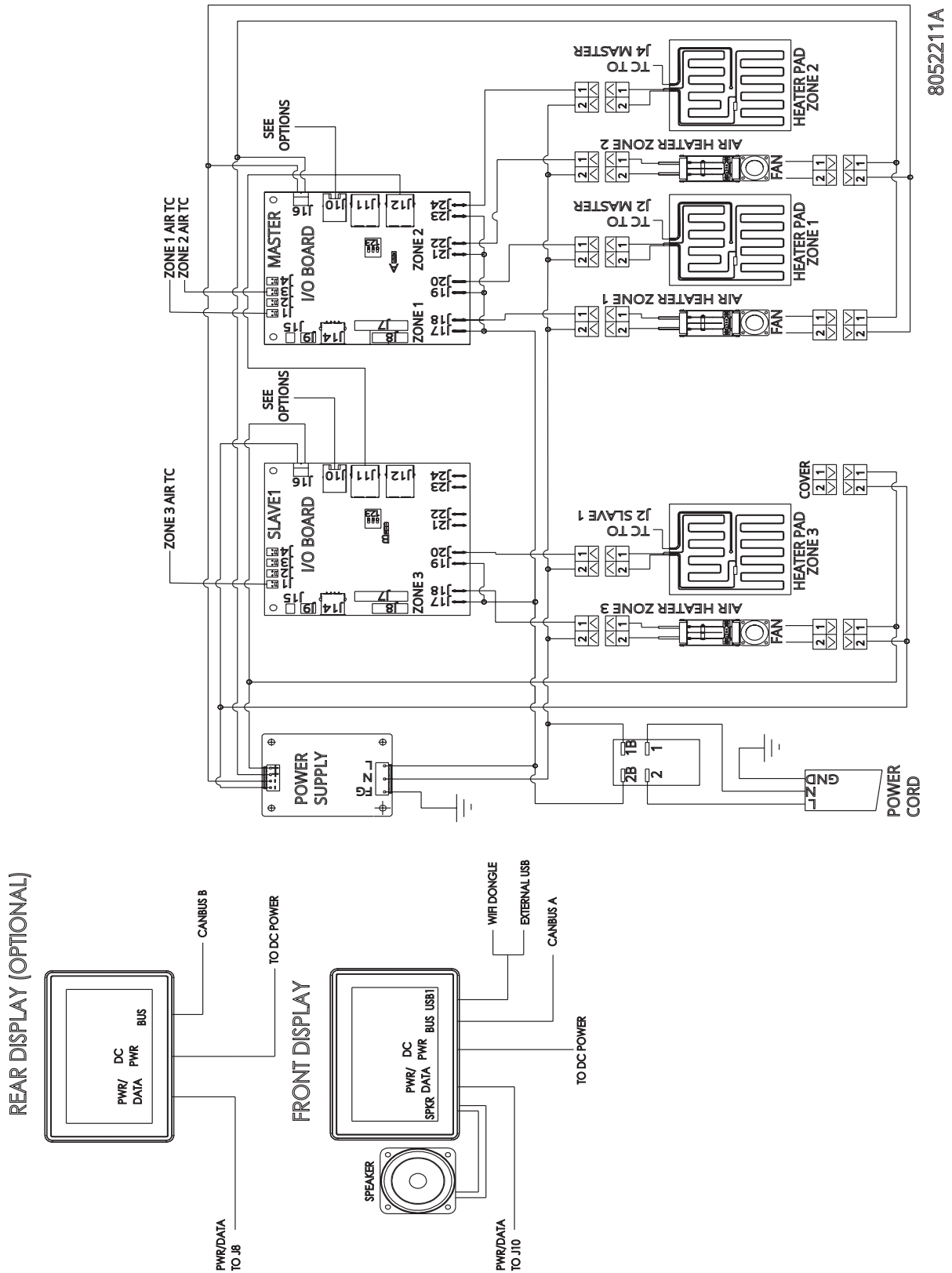

MHG - 4x2 Wiring

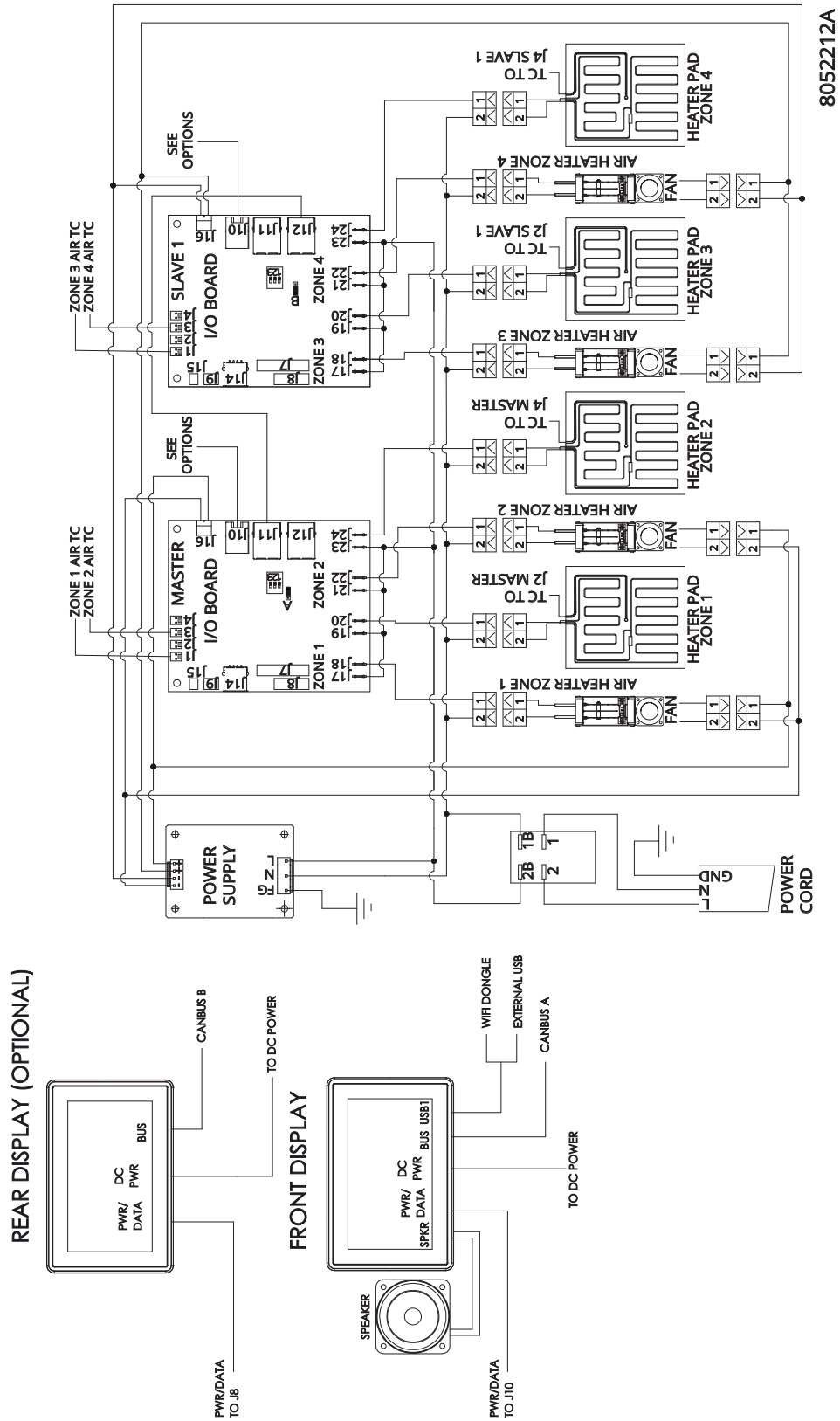

MHD - 4x2 Wiring

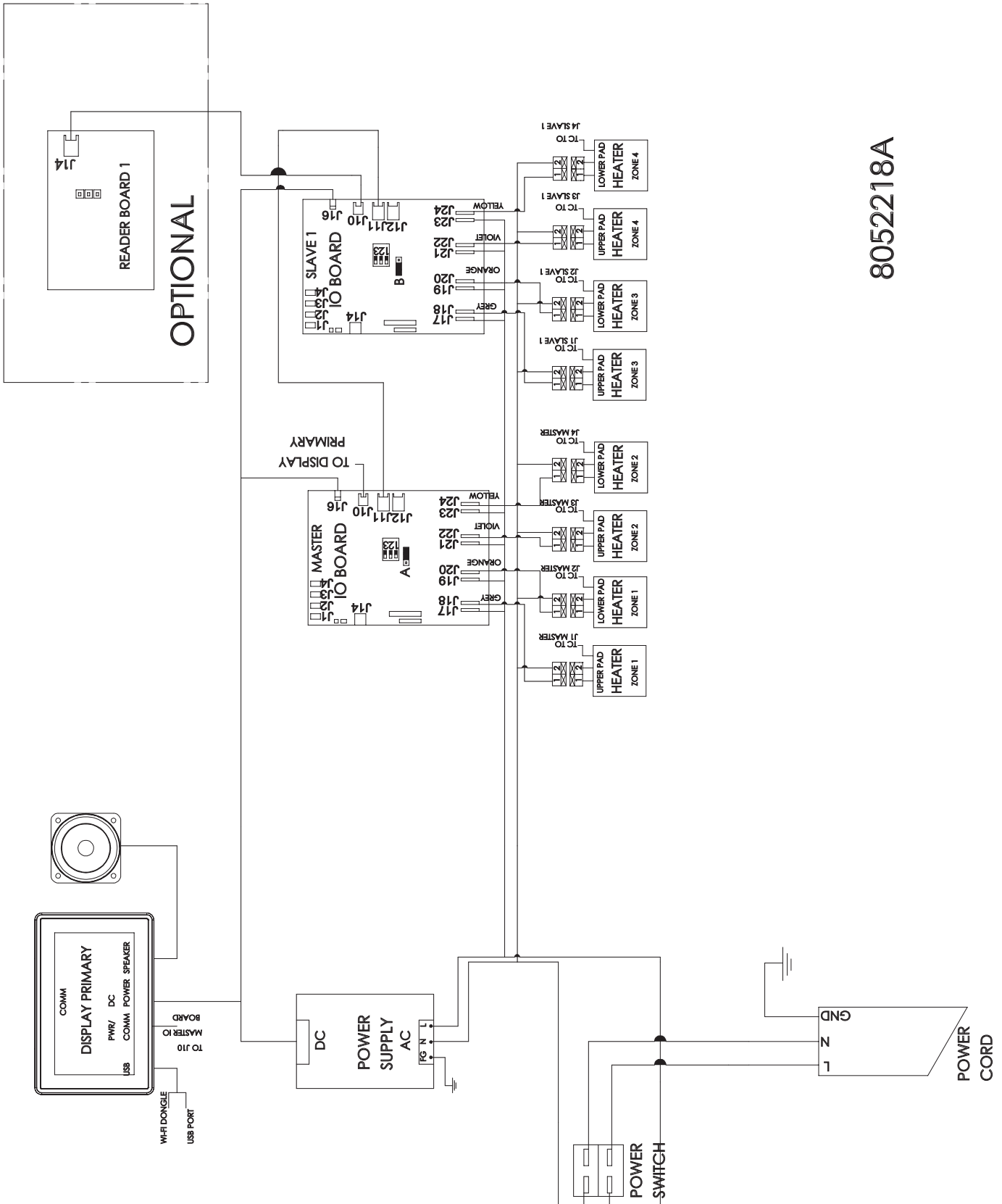

8052218A

MHD - 4x2 RFID Wiring

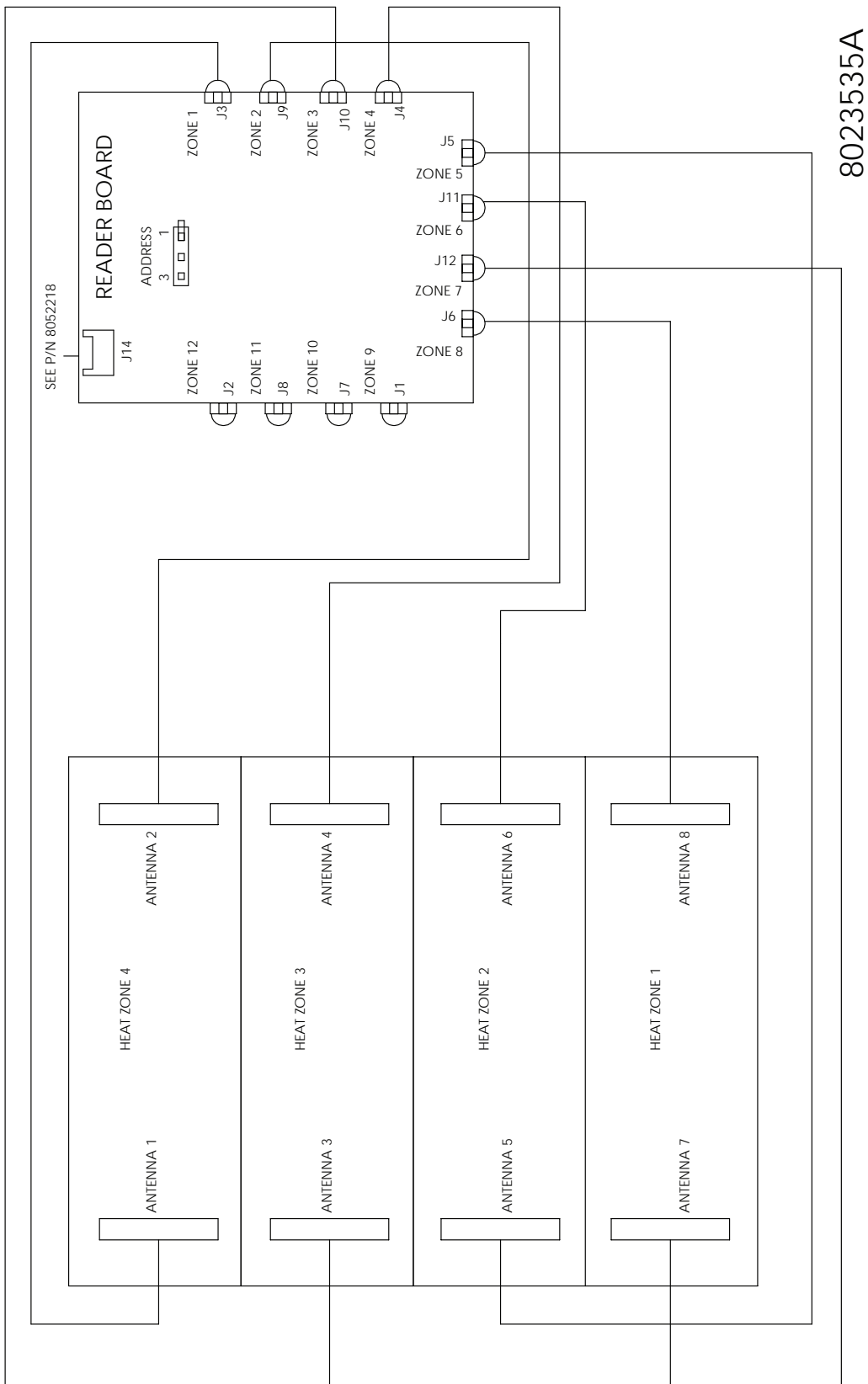

MHD - 8x2 Wiring

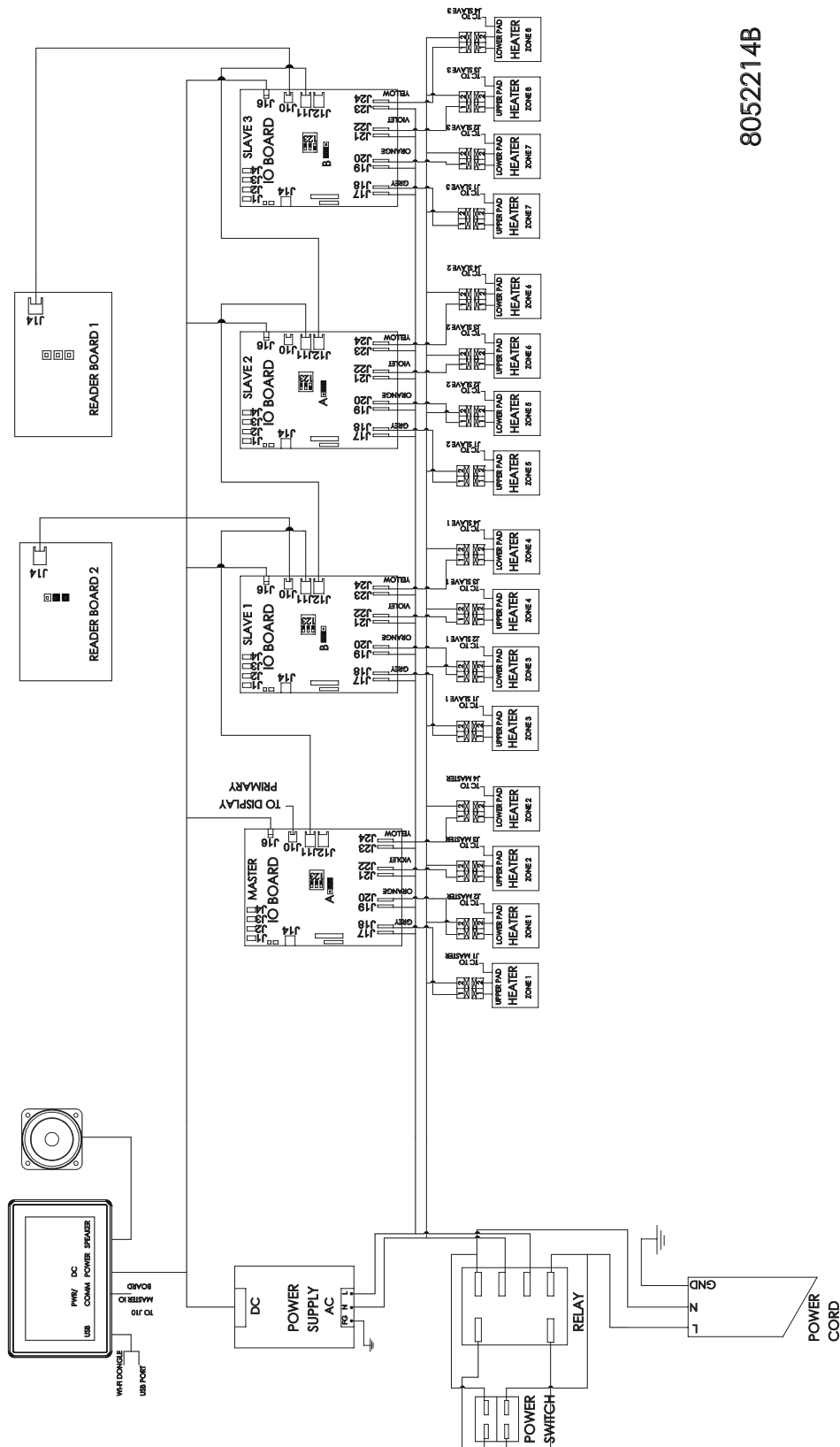

MHD - 8x2 RFID Wiring

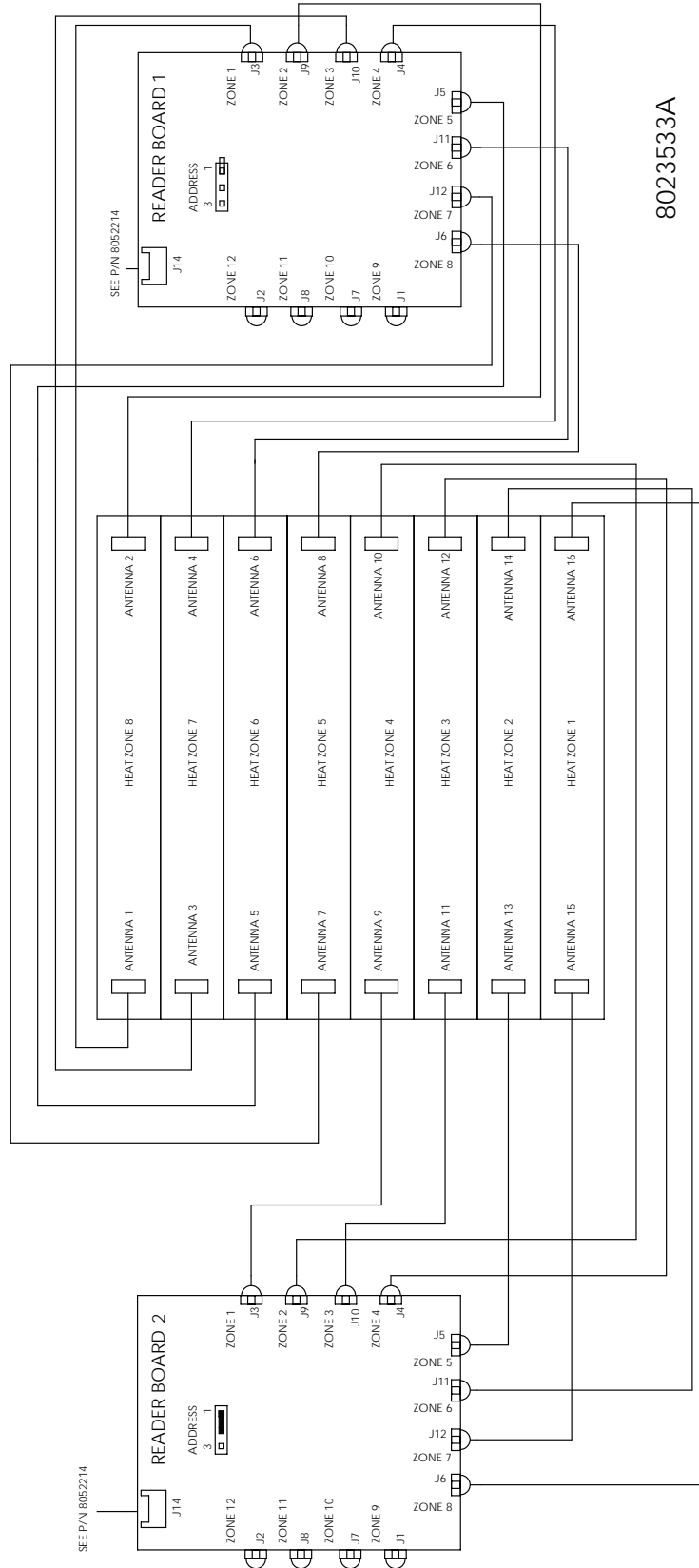

THIS PAGE INTENTIONALLY LEFT BLANK



MERCO
8700 LINE AVENUE, SHREVEPORT, LA 71106-6800

MERCO SALES: 800.221.4583
MERCO SERVICE: 877.392.7770
WWW.MERCOPRODUCTS.COM

Serving Quality on Demand



Welbilt offers fully-integrated kitchen systems and our products are backed by KitchenCare® aftermarket parts and service. Welbilt's portfolio of award-winning brands includes Cleveland™, Convotherm®, Crem®, Delfield®, fitkitchen®, Frymaster®, Garland®, Kolpak®, Lincoln®, Manitowoc®, Merco®, Merrychef® and Multiplex®.

Bringing innovation to the table • **welbilt.com**