

AQUAS™

COMMERCIAL POOL PACKAGE

Installation & Operation Manual Models: AP 285

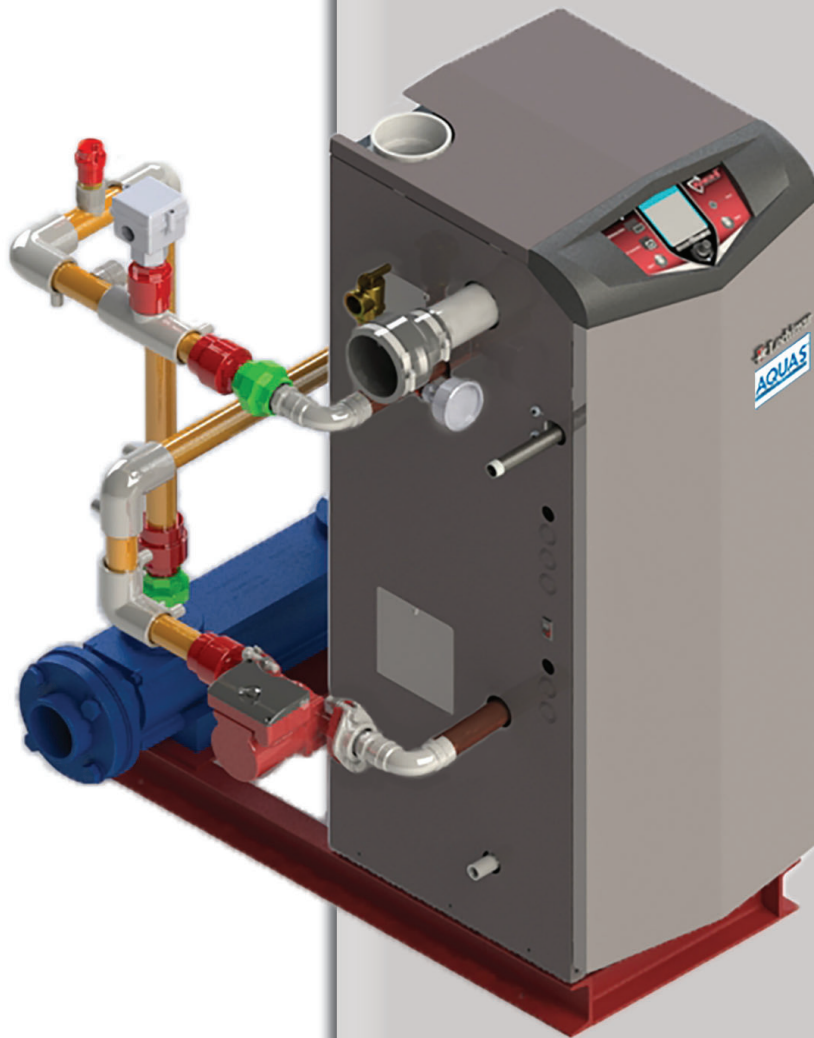

⚠ WARNING

This manual must only be used by a qualified heating installer/service technician. Read all instructions, including this manual and the AQUAS/Knight Fire Tube Boiler Service Manual, before installing. Perform steps in the order given. Failure to comply could result in severe personal injury, death, or substantial property damage.



Lochinvar®
HIGH EFFICIENCY BOILERS & WATER HEATERS

Save this manual for future reference.

Contents

HAZARD DEFINITIONS	2	6. HYDRONIC PIPING	
PLEASE READ BEFORE PROCEEDING	3-4	AQUAS Fire Tube Installation Instructions	36-37
THE AQUAS FIRE TUBE -- HOW IT WORKS	5-6	Indirect Heat Exchanger Installation Instructions.....	38
RATINGS	7	AQUAS Fire Tube Pool Setup	39
1. DETERMINE BOILER LOCATION		Standalone Operation	39
Provide Clearances	8	Auxiliary Heat Exchanger / DHW	40-42
Provide Air Openings to Room	10	Low Water Cutoff Device	43
Flooring and Foundation	10	Freeze Protection	43
Residential Garage Installation	10	General Piping Information	43
Vent and Air Piping	10	7. GAS CONNECTIONS	
Prevent Combustion Air Contamination.....	10	Connecting Gas Supply Piping	44-45
Corrosive Contaminants and Sources	11	Natural Gas	45
Using an Existing Vent System to Install a New Boiler ...	11	Pipe Sizing for Natural Gas	45
Removing a Boiler from Existing Common Vent.....	12	Natural Gas Supply Pressure Requirements	45
2. PREPARE BOILER		Propane Gas	45
Gas Conversions.....	13-14	Pipe Sizing for Propane Gas	45
3. GENERAL VENTING		Propane Supply Pressure Requirements	45
Direct Venting Options	15	Check Inlet Gas Supply	46
Install Vent and Combustion Air Piping	16	Gas Pressure	47
Requirements for Installation in Canada.....	17	Gas Valve Replacement	47
Sizing	17	8. FIELD WIRING	
Materials.....	18	Line Voltage Connections	48
Optional Room Air.....	19	Low Voltage Connections	48
PVC/CPVC	20	Wiring of the Cascade.....	50
Polypropylene.....	21	9. CONDENSATE DISPOSAL	
Stainless Steel Vent.....	22	Condensate Drain	53
4. SIDEWALL DIRECT VENTING		10. STARTUP	54-60
Vent/Air Termination - Sidewall.....	23-25	11. OPERATING INFORMATION	
Determine Location.....	23-25	General.....	61-64
Prepare Wall Penetrations.....	25-26	Cascade	65-66
Multiple Vent/Air Terminations	26	Sequence of Operation	67-68
Sidewall Termination - Optional Concentric Vent	27-29	AQUAS Fire Tube Control Module.....	69
5. VERTICAL DIRECT VENTING		Display Panel Menu Access	70
Vent/Air Termination - Vertical	30-31	Status Display Screens.....	71-73
Determine Location.....	30	12. MAINTENANCE	
Prepare Roof Penetrations	31	Maintenance and Annual Startup.....	74-78
Multiple Vent/Air Terminations.....	31	13. DIAGRAMS	
Vertical Termination - Optional Concentric Vent ...	32-33	Ladder Diagram	79
Alternate Vertical Concentric Venting.....	34-35	Wiring Diagram.....	80
		Revision Notes	Back Cover

Hazard definitions

The following defined terms are used throughout this manual to bring attention to the presence of hazards of various risk levels or to important information concerning the life of the product.

 **DANGER** DANGER indicates an imminently hazardous situation which, if not avoided, will result in death or serious injury.

 **WARNING** WARNING indicates a potentially hazardous situation which, if not avoided, could result in death or serious injury.

 **CAUTION** CAUTION indicates a potentially hazardous situation which, if not avoided, may result in minor or moderate injury.

CAUTION CAUTION used without the safety alert symbol indicates a potentially hazardous situation which, if not avoided, may result in property damage.

 **NOTICE** NOTICE indicates special instructions on installation, operation, or maintenance that are important but not related to personal injury or property damage.

Please read before proceeding

AQUAS Fire Tube Pool Package

The AQUAS Fire Tube pool package system is a high efficiency commercial condensing boiler, pre-piped package system from the factory to an indirect heat exchanger. This pool heater is a low temperature operating system designed to take advantage of the stainless steel heat exchanger and condensing operating temperatures to ensure the highest efficiency possible. The AQUAS is designed around a predetermined flow set by the manufacturer between the boiler and the indirect heat exchanger. The AQUAS operates off the pool system pump itself which will continually supply water to the indirect heat exchanger. This means there is no need to purchase a dedicated circulator to deliver water to this package system.

Figure A AQUAS Fire Tube Package System

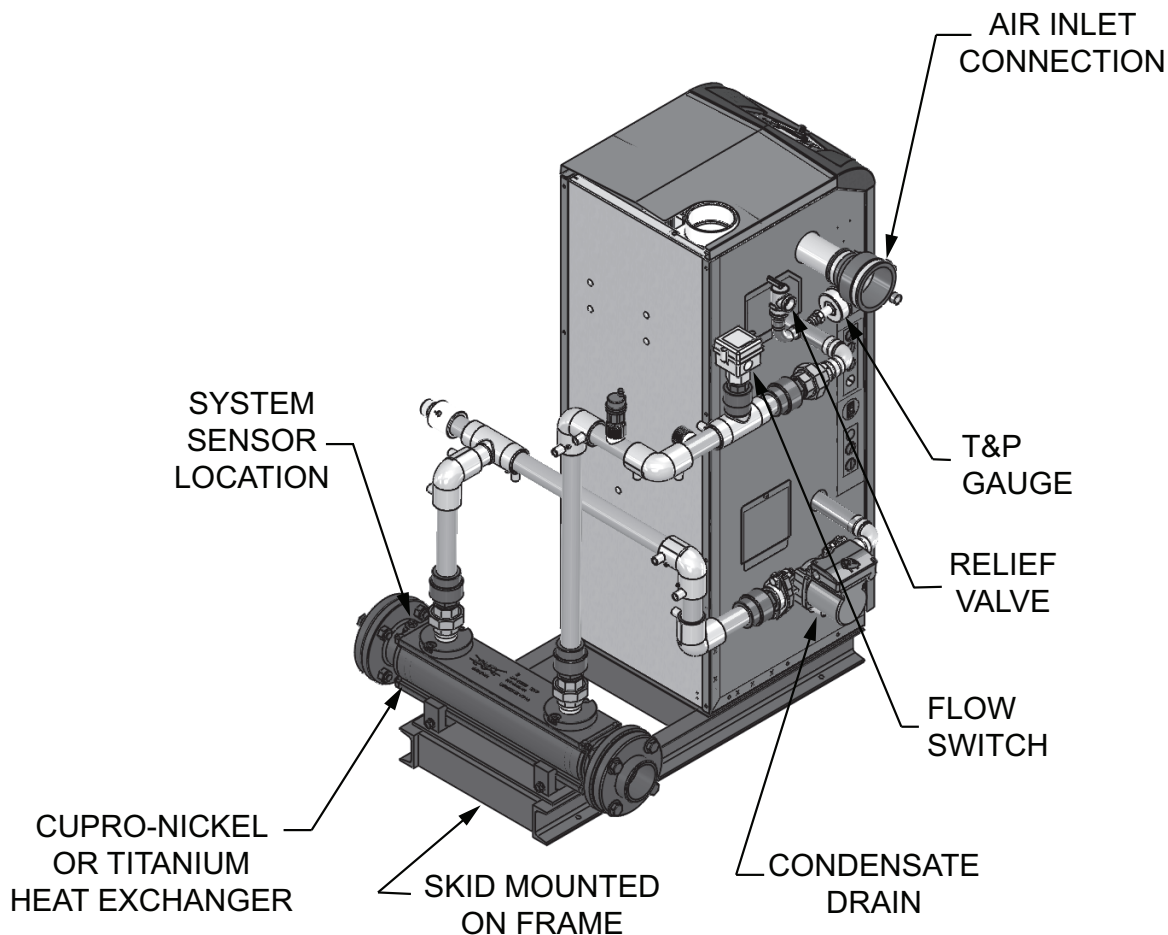

DIR# 2000538219 00

Please read before proceeding

⚠ WARNING

Installer – Read all instructions, including this manual and the Knight Fire Tube Boiler Service Manual, before installing. Perform steps in the order given.

User – This manual is for use only by a qualified heating installer/service technician. Refer to the User's Information Manual for your reference.

Have this boiler serviced/inspected by a qualified service technician, at least annually.

Failure to comply with the above could result in severe personal injury, death or substantial property damage.

NOTICE

When calling or writing about the boiler – Please have the boiler model and serial number from the boiler rating plate.

Consider piping and installation when determining boiler location.

Any claims for damage or shortage in shipment must be filed immediately against the transportation company by the consignee.

Factory warranty (shipped with unit) does not apply to units improperly installed or improperly operated.

⚠ WARNING

Failure to adhere to the guidelines on this page can result in severe personal injury, death, or substantial property damage.

⚠ WARNING

If the information in this manual is not followed exactly, a fire or explosion may result causing property damage, personal injury or loss of life.

This appliance **MUST NOT** be installed in any location where gasoline or flammable vapors are likely to be present.

WHAT TO DO IF YOU SMELL GAS

- Do not try to light any appliance.
- Do not touch any electric switch; do not use any phone in your building.
- Immediately call your gas supplier from a near by phone. Follow the gas supplier's instructions.
- If you cannot reach your gas supplier, call the fire department.
- Installation and service must be performed by a qualified installer, service agency, or the gas supplier.

⚠ WARNING

DO NOT install units in rooms or environments that contain corrosive contaminants (see Table 1B on page 11). Failure to comply could result in severe personal injury, death, or substantial property damage.

When servicing boiler –

- To avoid electric shock, disconnect electrical supply before performing maintenance.
- To avoid severe burns, allow boiler to cool before performing maintenance.

Boiler operation –

- Do not block flow of combustion or ventilation air to the boiler.
- Should overheating occur or gas supply fail to shut off, do not turn off or disconnect electrical supply to circulator. Instead, shut off the gas supply at a location external to the appliance.
- Do not use this boiler if any part has been under water. The possible damage to a flooded appliance can be extensive and present numerous safety hazards. Any appliance that has been under water must be replaced.

Boiler water –

- Thoroughly flush the system (without boiler connected) to remove sediment. The high-efficiency heat exchanger can be damaged by build-up or corrosion due to sediment.

⚠ CAUTION

Do not use petroleum-based cleaning or sealing compounds in the boiler system. Gaskets and seals in the system may be damaged. This can result in substantial property damage.

⚠ CAUTION

Do not use “homemade cures” or “boiler patent medicines”. Serious damage to the boiler, personnel, and/or property may result.

Freeze protection fluids –

- NEVER use automotive antifreeze. Use only inhibited propylene glycol solutions, which are specifically formulated for hydronic systems. Ethylene glycol is toxic and can attack gaskets and seals used in hydronic systems.

The AQUAS Fire Tube boiler - How it works...

- 1. Stainless steel heat exchanger**

Allows system water to flow around specially designed tubes for maximum heat transfer, while providing protection against flue gas corrosion.
- 2. Combustion chamber access cover**

Allows access to the combustion side of the heat exchanger.
- 3. Blower**

The blower pulls in air and gas through the venturi (item 5). Air and gas mix inside the blower and are pushed into the burner, where they burn inside the combustion chamber.
- 4. Gas valve**

The gas valve senses the negative pressure created by the blower, allowing gas to flow only if the gas valve is powered and combustion air is flowing.
- 5. Venturi**

The venturi controls air and gas flow into the burner.
- 6. Flue gas sensor (limit rated)**

This sensor monitors the flue gas exit temperature. The control module will modulate and shut down the boiler if flue gas temperature gets too hot. This protects the flue pipe from overheating.
- 7. Boiler outlet temperature sensor (housed with the high limit sensor)**

This sensor monitors boiler outlet water temperature (system supply). If selected as the controlling sensor, the control module adjusts boiler firing rate so the outlet temperature is correct.
- 8. Boiler inlet temperature sensor**

This sensor monitors return water temperature (system return). If selected as the controlling sensor, the control module adjusts the boiler firing rate so the inlet temperature is correct.
- 9. Temperature and pressure gauge**

Monitors the outlet temperature of the boiler as well as the system water pressure.
- 10. Electronic LCD display**

The display features a high resolution liquid crystal screen, four (4) buttons, and a navigation dial. A serial and USB port support additional communication with the control.
- 11. Flue pipe adapter**

Allows for the connection of the vent system to the boiler.
- 12. Burner (not shown)**

Made with metal fiber and stainless steel construction, the burner uses pre-mixed air and gas and provides a wide range of firing rates.
- 13. Water inlet (system return)**

Copper water connection that returns water from the system to the heat exchanger, either 1-1/4".
- 14. Gas connection pipe**

Threaded pipe connection. This pipe should be connected to the incoming gas supply for the purpose of delivering gas to the boiler.
- 15. SMART SYSTEM Control Module**

The SMART SYSTEM Control responds to internal and external signals to regulate the blower, gas valve, and pump functions to meet heating demand. Optional remote connectivity allows boiler settings to be monitored and modified when connected to the internet.
- 16. Air intake adapter**

Allows for the connection of the PVC air intake pipe to the boiler.
- 17. High voltage junction box**

The junction box contains the connection points for the line voltage power and all pumps.
- 18. Low voltage connection board**

The connection board is used to connect external low voltage devices.
- 19. Low voltage wiring connections (knockouts)**

Conduit connection points for the low voltage connection board.
- 20. Condensate trap**

The condensate trap has a 1/2" CPVC outlet connection pipe.
- 21. Access cover - front**

Provides access to the gas valve, control panel, and heat exchanger.
- 22. Ignition electrode**

Provides direct spark for igniting the burner.
- 23. Flame inspection window**

The quartz glass window provides a view of the burner surface and flame.
- 24. Relief valve**

Protects the heat exchanger from an over pressure condition. The relief valve provided with the unit is set at 30 psi.
- 25. Flame sensor**

Used by the control module to detect the presence of burner flame.
- 26. Line voltage wiring connections (knockouts)**

Conduit connection points for the high voltage junction box.
- 27. Top panel**

Removable panel allows access to the gas train and combustion chamber.
- 28. Side access panels**

Remove panels to gain access to temperature sensors.
- 29. Power switch**

Turns 120 VAC ON/OFF to the boiler.
- 30. Leveling legs**

Used to allow the heat exchanger to be leveled. This is needed for the proper draining of the condensate from the combustion chamber.
- 31. Flue and temperature access door**

Provides access to the flue and temperature sensor.
- 32. Transformer**

The transformer provides 24V power to the integrated control.
- 33. High limit sensor (housed with the outlet temperature sensor)**

Device that monitors the outlet water temperature. If the temperature exceeds its setting, the integrated control will break the control circuit, shutting the boiler down.
- 34. Stainless steel flue collector (not shown)**

Flue gas and condensate enter the stainless flue collector through the fire tubes. A 1" drain connection allows condensate to flow through the collector into a condensate trap for disposal.

The AQUAS Fire Tube boiler - How it works...

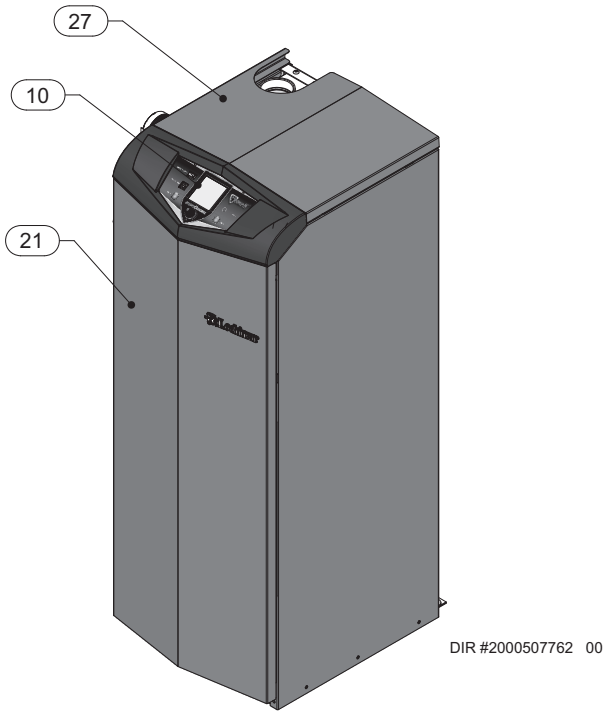

DIR #2000507762 00

Front View

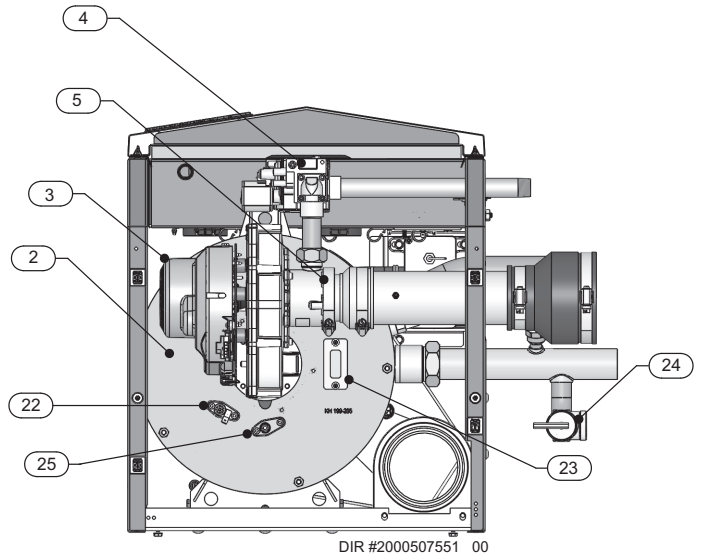

DIR #2000507551 00

Top View (inside unit)

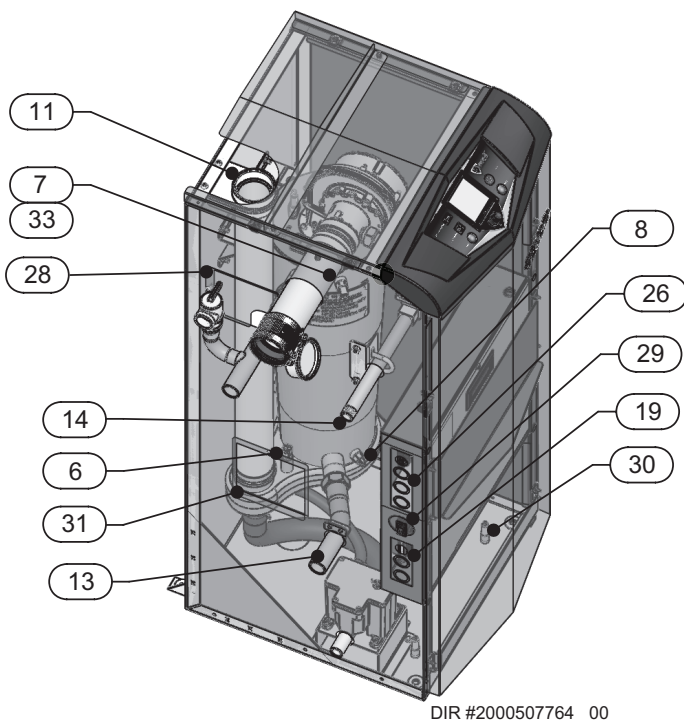

DIR #2000507764 00

Left Side (inside unit)

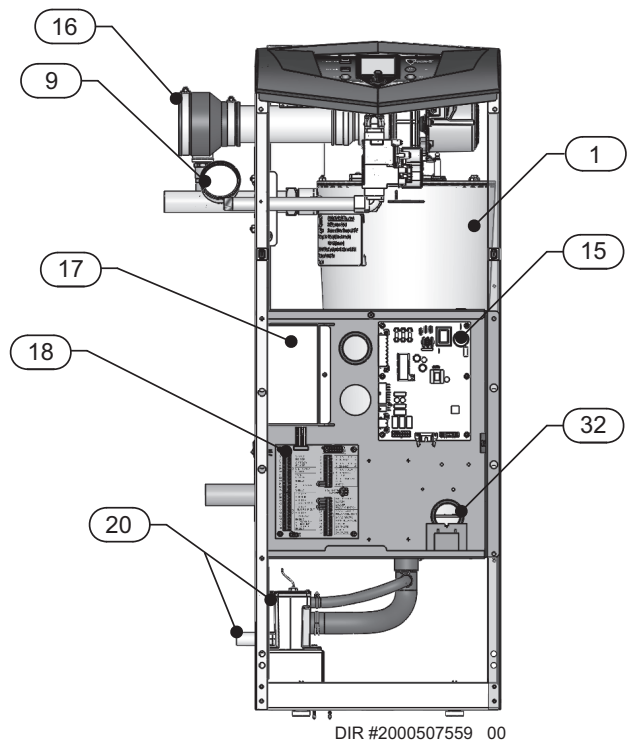

DIR #2000507559 00

Front View (inside unit)

Ratings

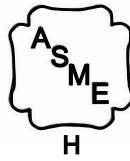

DOE



AQUAS Fire Tube boiler AHRI Rating						Other Specifications				
Model Number Note: Change "N" to "L" for L.P. gas models.	Input MBH (Note 5)		Heating Capacity MBH	Net AHRI Ratings Water, MBH	AFUE %	Boiler Water Content Gallons	Water Connections	Gas Connections	Air Size	Vent Size (Note 4,8)
	Min	Max	(Note 2,7)	(Note 3,7)	(Note 1, 7)					
APN285	28.5	285	264	229	95	4.9	1-1/4"	1/2"	3"	3"

NOTICE Maximum allowed working pressure is located on the rating plate.

Notes:

- As an Energy Star Partner, Lochinvar has determined that AQUAS Fire Tube boilers meet the Energy Star guidelines for energy efficiency.
- The ratings are based on standard test procedures prescribed by the United States Department of Energy.
- Net AHRI ratings are based on net installed radiation of sufficient quantity for the requirements of the building and nothing need be added for normal piping and pickup. Ratings are based on a piping and pickup allowance of 1.15.
- AQUAS Fire Tube boilers require special gas venting. Use only the vent materials and methods specified in the AQUAS Fire Tube boiler Installation and Operation Manual.
- Standard AQUAS Fire Tube boilers are equipped to operate from sea level to 4,500 feet **only**. The boiler will de-rate by 4% for each 1,000 feet above sea level up to 4,500 feet.
- High altitude AQUAS Fire Tube boilers are equipped to operate from 3,000 to 9,600 feet **only**. The boiler will not de-rate up to 5,000 feet and will de-rate 1.7% for each 1000 feet above 5000 feet. The operation given in this manual remains the same as the standard boilers. A high altitude label (as shown in FIG. B) is also affixed to the unit.
De-rate values are based on proper combustion calibration and CO₂'s adjusted to the recommended levels.
- Ratings have been confirmed by the Hydronics Section of AHRI.

- The AP285 model can be alternatively vented using a 4" vent/air size. If the 3" vent/air size is used, the maximum vent/air pipe lengths are limited to 50 equivalent feet each.
- The manual reset high limit provided with the AQUAS Fire Tube boiler is listed to UL353.

Figure B High Altitude Label Location

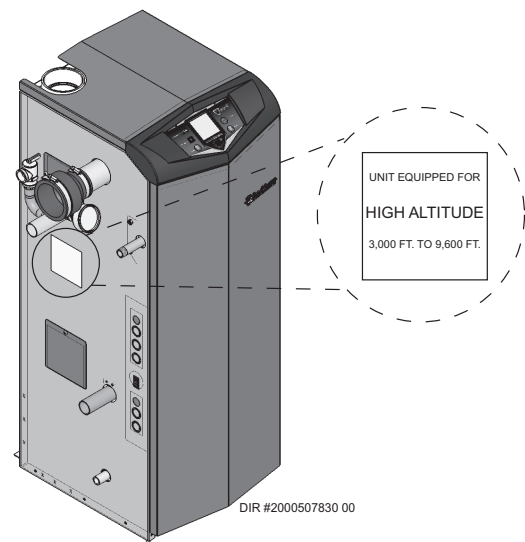

1 Determine boiler location

Installation must comply with:

- Local, state, provincial, and national codes, laws, regulations, and ordinances.
- National Fuel Gas Code, ANSI Z223.1 – latest edition.
- Standard for Controls and Safety Devices for Automatically Fired Boilers, ANSI/ASME CSD-1, when required.
- National Electrical Code.
- For Canada only: B149.1 Installation Code, CSA C22.1 Canadian Electrical Code Part 1 and any local codes.

NOTICE

The AQUAS Fire Tube boiler gas manifold and controls met safe lighting and other performance criteria when the boiler underwent tests specified in ANSI Z21.13 – latest edition.

Before locating the boiler, check:

1. Check for nearby connection to:
 - System water piping
 - Venting connections
 - Gas supply piping
 - Electrical power
2. Locate the appliance so that if water connections should leak, water damage will not occur. When such locations cannot be avoided, it is recommended that a suitable drain pan, adequately drained, be installed under the appliance. The pan must not restrict combustion air flow. Under no circumstances is the manufacturer to be held responsible for water damage in connection with this appliance, or any of its components.
3. Check area around the boiler. Remove any combustible materials, gasoline, and other flammable liquids.

WARNING

Failure to keep boiler area clear and free of combustible materials, gasoline, and other flammable liquids and vapors can result in severe personal injury, death, or substantial property damage.

4. The AQUAS Fire Tube boiler must be installed so that gas control system components are protected from dripping or spraying water or rain during operation or service.
5. If a new boiler will replace an existing boiler, check for and correct system problems, such as:
 - System leaks causing oxygen corrosion or heat exchanger cracks from hard water deposits.
 - Incorrectly-sized expansion tank.
 - Lack of freeze protection in boiler water causing system and boiler to freeze and leak.
6. Check around the boiler for any potential air contaminants that could risk corrosion to the boiler or the boiler combustion air supply (see Table 1B on page 11). Prevent combustion air contamination. Remove any of these contaminants from the boiler area.

WARNING

DO NOT install units in rooms or environments that contain corrosive contaminants (see Table 1B on page 11). Failure to comply could result in severe personal injury, death, or substantial property damage.

WARNING

This appliance is certified as an indoor appliance. Do not install the appliance outdoors or locate where the appliance will be exposed to freezing temperatures or to temperatures that exceed 100°F.

Do not install the appliance where the relative humidity may exceed 93%. Do not install the appliance where condensation may form on the inside or outside of the appliance, or where condensation may fall onto the appliance. Failure to install the appliance indoors could result in severe personal injury, death, or substantial property damage.

WARNING

This appliance requires a special venting system. If using PVC the vent connection to the appliance must be made with the starter CPVC pipe section provided with the appliance. The field provided vent fittings must be cemented to the CPVC pipe section. Use only the vent materials, primer and cement specified in this manual to make the vent connections. Failure to follow this warning could result in fire, personal injury, or death.

Closet and alcove installations

A closet is any room the boiler is installed in which the room volume is less than the room volume listed in the table below. An alcove is any room which meets the criteria for a closet, but it does not have a door.

Table 1A Room Volume

Model	Room Volume (in cubic feet)
285	124

Example: Room dimensions = 4 feet long, 3 feet wide, and 8 foot ceiling = 4 x 3 x 8 = 96 cubic feet. This would be considered a closet for a APN285 model.

WARNING

For closet and alcove installations as shown in FIG.'s 1-1 and 1-2, CPVC, polypropylene or stainless steel vent material must be used inside the structure. The ventilating air openings shown in FIG.'s 1-1 and 1-2 are required for this arrangement. Failure to follow this warning could result in fire, personal injury, or death.

Provide clearances:

Clearances from combustible materials

1. Hot water pipes—at least 1/4" (6 mm) from combustible materials.
2. Vent pipe – at least 1" (25 mm) from combustible materials.
3. See FIG.'s 1-1 and 1-2 on page 9 for other clearance minimums.

1 Determine boiler location *(continued)*

Figure 1-1 Closet Installation - Minimum Required Clearances

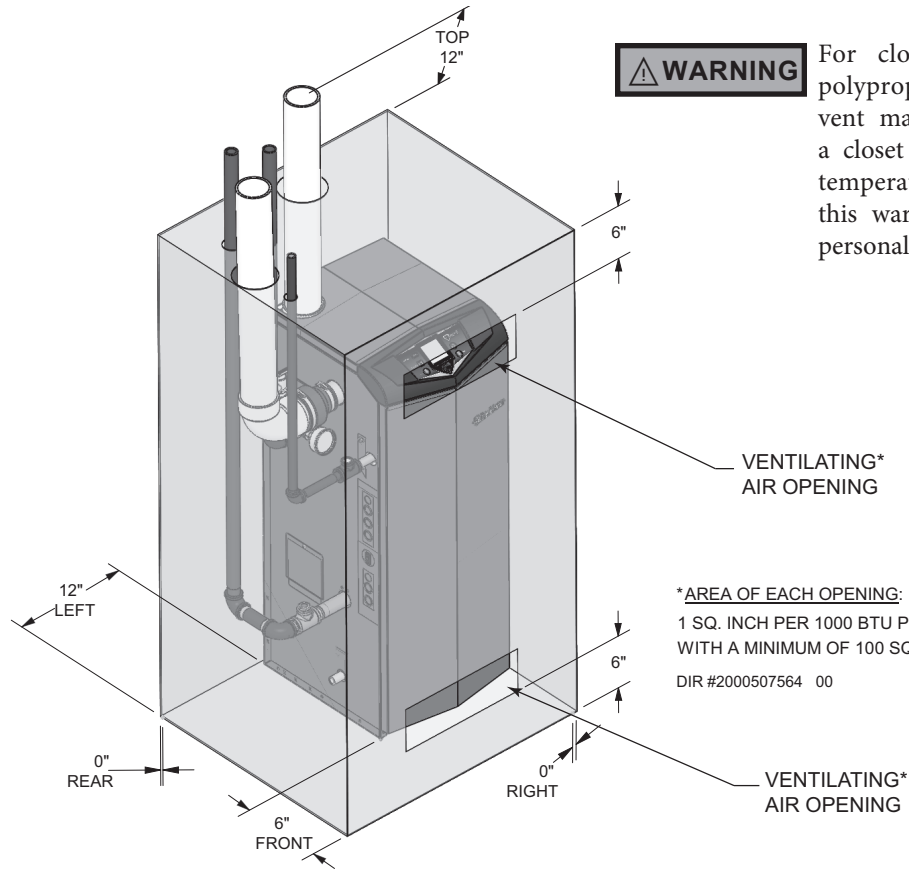
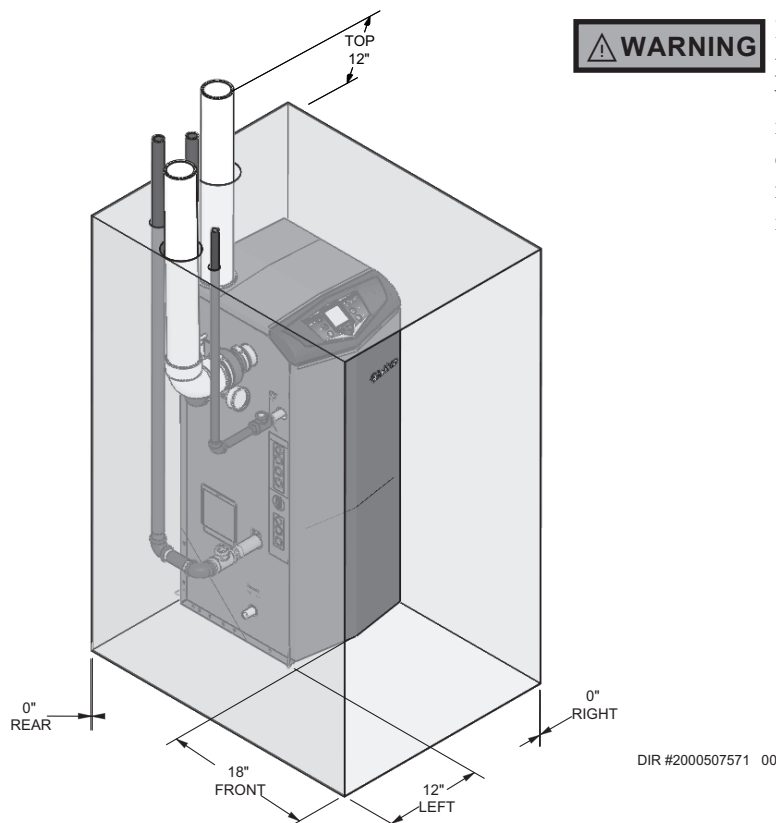

Figure 1-2 Alcove Installation - Minimum Required Clearances



1 Determine boiler location

NOTICE

If you do not provide the recommended service clearances shown, it may not be possible to service the boiler without removing it from the space.

Recommended clearances for service access

- Front 24"
- Left 24"
- Top 24"

Provide air openings to room:

AQUAS Fire Tube boiler alone in boiler room

1. No air ventilation openings into the boiler room are needed when clearances around the AQUAS Fire Tube boiler are at least equal to the SERVICE clearances shown above. For spaces that do NOT supply this clearance, provide two openings as shown in FIG. 1-1. Each opening must provide one square inch free area per 1,000 Btu/hr of boiler input.

AQUAS Fire Tube boiler in same space with other gas or oil-fired appliances

1. Follow the National Fuel Gas Code (U.S.) or CSA B149.1 (Canada) to size/verify size of the combustion/ventilation air openings into the space.

WARNING

The space must be provided with combustion/ventilation air openings correctly sized for all other appliances located in the same space as the AQUAS Fire Tube boiler.

Do not install the boiler in an attic.

Failure to comply with the above warnings could result in severe personal injury, death, or substantial property damage.

2. Size openings only on the basis of the other appliances in the space. No additional air opening free area is needed for the AQUAS Fire Tube boiler because it takes its combustion air from outside (direct vent installation).

Flooring and foundation

Flooring

The AQUAS Fire Tube boiler is approved for installation on combustible flooring, but must never be installed on carpeting.

WARNING

Do not install the boiler on carpeting even if foundation is used. Fire can result, causing severe personal injury, death, or substantial property damage.

If flooding is possible, elevate the boiler sufficiently to prevent water from reaching the boiler.

Residential garage installation

Precautions

Take the following precautions when installing the appliance in a residential garage. If the appliance is located in a residential garage, it should be installed in compliance with the latest edition of the National Fuel Gas Code, ANSI Z223.1 and/or CAN/CGA-B149 Installation Code.

- Appliances located in residential garages and in adjacent spaces that open to the garage and are not part of the living space of a dwelling shall be installed so that all burners and burner ignition devices are located not less than 18 inches (46 cm) above the floor.
- The appliance shall be located or protected so that it is not subject to physical damage by a moving vehicle.

Vent and air piping

The AQUAS Fire Tube boiler requires a special vent system, designed for pressurized venting.

The boiler is to be used for either direct vent installation or for installation using indoor combustion air. When room air is considered, see Section 3, General Venting. Note prevention of combustion air contamination below when considering vent/air termination.

Vent and air must terminate near one another and may be vented vertically through the roof or out a side wall, unless otherwise specified. You may use any of the vent/air piping methods covered in this manual. Do not attempt to install the AQUAS Fire Tube boiler using any other means.

Be sure to locate the boiler such that the vent and air piping can be routed through the building and properly terminated. The vent/air piping lengths, routing and termination method must all comply with the methods and limits given in this manual.

Prevent combustion air contamination

Install air inlet piping for the AQUAS Fire Tube boiler as described in this manual. Do not terminate vent/air in locations that can allow contamination of combustion air. Refer to Table 1B, page 11 for products and areas which may cause contaminated combustion air.

WARNING

You must pipe combustion air to the boiler air intake. Ensure that the combustion air will not contain any of the contaminants in Table 1B, page 11. Contaminated combustion air will damage the boiler, resulting in possible severe personal injury, death, or substantial property damage. Do not pipe combustion air near a swimming pool, for example. Also, avoid areas subject to exhaust fumes from laundry facilities. These areas will always contain contaminants.

1 Determine boiler location *(continued)*

Table 1B Corrosive Contaminants and Sources

Products to avoid:
Spray cans containing chloro/fluorocarbons
Permanent wave solutions
Chlorinated waxes/cleaners
Calcium chloride used for thawing
Sodium chloride used for water softening
Refrigerant leaks
Paint or varnish removers
Hydrochloric acid/muriatic acid
Cements and glues
Antistatic fabric softeners used in clothes dryers
Chlorine-type bleaches, detergents, and cleaning solvents found in household laundry rooms
Adhesives used to fasten building products and other similar products
Areas likely to have contaminants
Dry cleaning/laundry areas and establishments
Metal fabrication plants
Beauty shops
Refrigeration repair shops
Photo processing plants
Auto body shops
Plastic manufacturing plants
Furniture refinishing areas and establishments
New building construction
Remodeling areas
Garages with workshops

When using an existing vent system to install a new boiler:



WARNING Failure to follow all instructions can result in flue gas spillage and carbon monoxide emissions, causing severe personal injury or death.

Check the following venting components before installing:

- **Material** - For materials listed for use with this appliance, see Section 3 - General Venting. For polypropylene or stainless steel venting, an adapter of the same manufacturer must be used at the flue collar connection.
- **Size** - To ensure proper pipe size is in place, see Table 3A. Check to see that this size is used throughout the vent system.
- **Manufacturer** - For a stainless steel or polypropylene application, you must use only the listed manufacturers and their type product listed in Tables 3E and 3G for CAT IV positive pressure venting with flue producing condensate.
- **Supports** - Non-combustible supports must be in place allowing a minimum 1/4" rise per foot. The supports should adequately prevent sagging and vertical slippage, by distributing the vent system weight. For additional information, consult the vent manufacturer's instructions for installation.
- **Terminations** - Carefully review Sections 3 through 5 to ensure requirements for the location of the vent and air terminations are met and orientation of these fit the appropriate image from the Sidewall or Vertical options listed in the General Venting Section. For stainless steel vent, only use terminations listed in Table 3G for the manufacturer of the installed vent.
- **Seal** - With prior requirements met, the system should be tested to the procedure listed in parts (c) through (f) of the Removal of an Existing Boiler Section on page 12.

With polypropylene and stainless steel vent, seal and connect all pipe and components as specified by the vent manufacturer used; with PVC/CPVC vent, see the Installing Vent and Air Piping Section on page 16.



WARNING If any of these conditions are not met, the existing system must be updated or replaced for that concern. Failure to follow all instructions can result in flue gas spillage and carbon monoxide emissions, causing severe personal injury or death.

1 Determine boiler location

When removing a boiler from existing common vent system:

DANGER

Do not install the AQUAS into a common vent with any other appliance. This will cause flue gas spillage or appliance malfunction, resulting in possible severe personal injury, death, or substantial property damage.

WARNING

Failure to follow all instructions can result in flue gas spillage and carbon monoxide emissions, causing severe personal injury or death.

At the time of removal of an existing boiler, the following steps shall be followed with each appliance remaining connected to the common venting system placed in operation, while the other appliances remaining connected to the common venting system are not in operation.

- a. Seal any unused openings in the common venting system.
- b. Visually inspect the venting system for proper size and horizontal pitch and determine there is no blockage or restriction, leakage, corrosion, or other deficiencies, which could cause an unsafe condition.
- c. Test vent system – Insofar as is practical, close all building doors and windows and all doors between the space in which the appliances remaining connected to the common venting system are located and other spaces of the building. Turn on clothes dryers and any appliance not connected to the common venting system. Turn on any exhaust fans, such as range hoods and bathroom exhausts, so they will operate at maximum speed. Do not operate a summer exhaust fan. Close fireplace dampers.
- d. Place in operation the appliance being inspected. Follow the lighting instructions. Adjust thermostat so appliance will operate continuously.
- e. Test for spillage at the draft hood relief opening after 5 minutes of main burner operation. Use the flame of a match or candle, or smoke from a cigarette, cigar, or pipe.
- f. After it has been determined that each appliance remaining connected to the common venting system properly vents when tested as outlined herein, return doors, windows, exhaust fans, fireplace dampers, and any other gas-burning appliance to their previous conditions of use.
- g. Any improper operation of the common venting system should be corrected so the installation conforms with the National Fuel Gas Code, ANSI Z223.1/NFPA 54 and/or CAN/CSA B149.1, Natural Gas and Propane Installation Code. When resizing any portion of the common venting system, the common venting system should be resized to approach the minimum size as determined using the appropriate tables in Part 11 of the National Fuel Gas Code, ANSI Z223.1/NFPA and/or CAN/CSA B149.1, Natural Gas and Propane Installation Code.

2 Prepare boiler

Gas conversions

⚠ WARNING

For a boiler already installed, you must turn off gas supply, turn off power, and allow boiler to cool before proceeding. You must also completely test the boiler after conversion to verify performance as described under Start-up, Section 10 of this manual. Failure to comply could result in severe personal injury, death, or substantial property damage.

You must install a propane venturi to operate the AQUAS Fire Tube boiler on propane gas. Verify when installing that the venturi label marking matches the boiler size (see Table 2A).

Table 2A LP Conversion Table

Model	Kit #	Venturi Ø (mm)	Orifice Ø		Air Shutter
			Bottom	Top	
285	100268109	30 mm	4.20 mm	4.00 mm	100150434

*Note: The air shutter should have the hole oriented towards the back right corner of the unit.

1. If boiler is already installed, you must turn off the gas supply, turn off the power, and allow the boiler to cool before proceeding.
2. Remove the top panel front access cover from the unit (no tools required for removal) and remove the bezel.
3. Disconnect the air inlet piping from the venturi by loosening the band clamp around the rubber boot coupling. Slide the rubber boot off of the venturi.
4. Disconnect gas piping from the venturi by loosening the threaded nut on the venturi. Remove the gasket between the gas piping and venturi.
5. Remove the bolts connecting the venturi to the fan and proceed to remove the natural gas venturi from the unit, making sure not to damage the blower O-ring gasket (FIG. 2-1).
6. This unit requires an air shutter to be installed (see Table 2A):
 - a. Disconnect the wiring from the fan and remove the bolts securing the fan to the combustion chamber access cover.
 - b. Remove the fan and gasket, and install the air shutter provided in the kit. Install the air shutter so that the hole in the corner is oriented towards the back right corner of the unit (opposite the front door and gas piping).
 - c. Replace all torn or damaged gaskets. Reassemble the fan.
 - d. Reconnect the wiring harness before operation.
7. Install the propane venturi and verify the following:
 - a. The UP arrow on the plastic housing is pointing up.
 - b. The threaded connection for the gas piping is facing towards the front of the unit.
8. Reassemble the gas pipe to the threaded connection on the venturi. Replace torn or damaged gasket(s) and ensure the venturi gasket is seated properly before tightening the nut on the venturi.
9. Reconnect the rubber boot on the air inlet to the venturi inlet and tighten the band clamp at this connection.
10. After installation is complete, attach the propane conversion label (inside the conversion kit) next to the boiler rating plate. Attach the LP caution label (inside the conversion kit bag) to the left side of the boiler underneath the gas supply piping.
11. Replace the top bezel and front access cover removed in Step 1 and resume operation.

2 Prepare boiler

⚠ DANGER

When removing the natural gas venturi, inspect the gasket at the gas connection and the O-ring at the blower. These gaskets must be in good condition and must be installed. Failure to comply will cause a gas leak, resulting in severe personal injury or death.

Figure 2-1 Remove Natural Gas Venturi

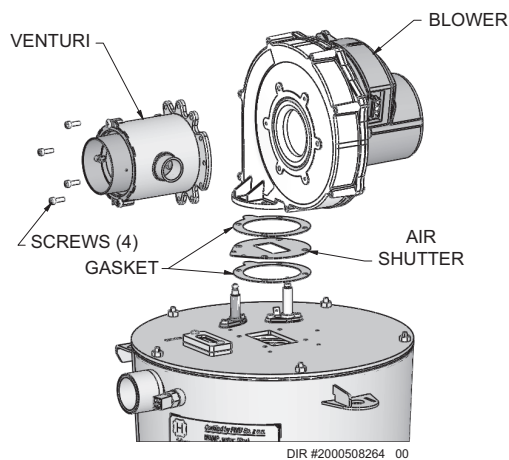

⚠ WARNING

After converting to LP, check combustion per the Start-up procedure in Section 10 of this manual. Failure to check and verify combustion could result in severe personal injury, death, or substantial property damage.

3 General venting

Direct venting options - Sidewall Vent

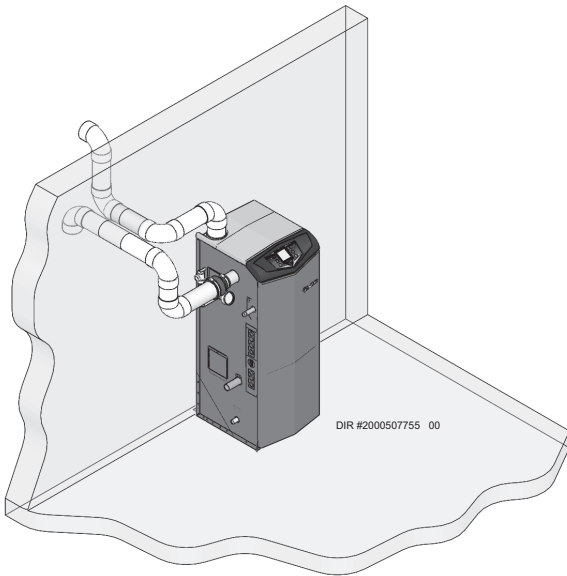

Figure 3-1 Two-Pipe Sidewall Termination - See page 23 for more details

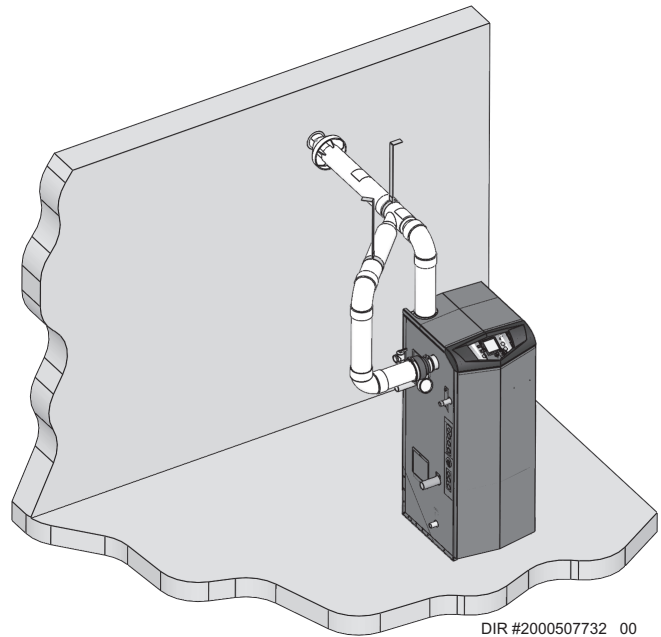

Figure 3-2 PVC/CPVC Concentric Sidewall Termination - See page 27 for more details

Direct venting options - Vertical Vent

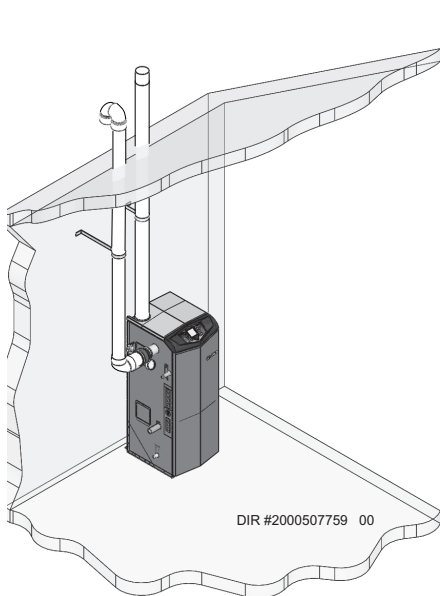

Figure 3-3 Two-Pipe Vertical Termination - See page 30 for more details

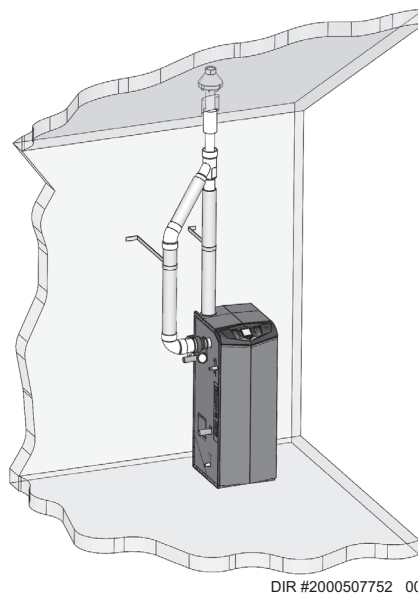

Figure 3-4 PVC/CPVC Concentric Vertical Termination - See page 32 for more details

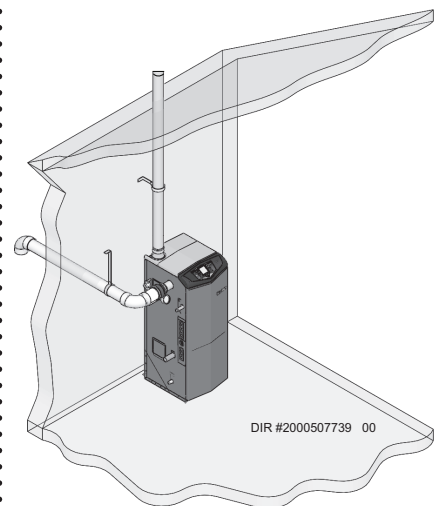

Figure 3-5 Vertical Vent, Sidewall Air

3 General venting

Install vent and combustion air piping

⚠ DANGER

The AQUAS Fire Tube boiler must be vented and supplied with combustion and ventilation air as described in this section. Ensure the vent and air piping and the combustion air supply comply with these instructions regarding vent system, air system, and combustion air quality. See also Section 1 of this manual.

Inspect finished vent and air piping thoroughly to ensure all are airtight and comply with the instructions provided and with all requirements of applicable codes.

Failure to provide a properly installed vent and air system will cause severe personal injury or death.

⚠ WARNING

This appliance requires a special venting system. Use only approved stainless steel, PVC, CPVC or polypropylene pipe and fittings listed in Tables 3D, 3E, and 3G for vent pipe and fittings. Failure to comply could result in severe personal injury, death, or substantial property damage.

⚠ WARNING

DO NOT mix components from different systems. The vent system could fail, causing leakage of flue products into the living space. Mixing of venting materials will void the warranty and certification of the appliance.

NOTICE

Installation must comply with local requirements and with the National Fuel Gas Code, ANSI Z223.1 for U.S. installations or CSA B149.1 for Canadian installations.

⚠ WARNING

For closet and alcove installations, CPVC, polypropylene, or stainless steel material **MUST BE** used in a closet/alcove structure. Failure to follow this warning could result in fire, personal injury, or death.

⚠ CAUTION

Improper installation of venting systems may result in injury or death.

NOTICE

Follow the instructions in Section 1, page 12 of this manual when removing a boiler from an existing vent system.

⚠ WARNING

Do not connect any other appliance to the vent pipe or multiple boilers to a common vent pipe. Failure to comply could result in severe personal injury, death, or substantial property damage.

The AQUAS Fire Tube boiler vent and air piping can be installed through the roof or through a sidewall. Follow the procedures in this manual for the method chosen. Refer to the information in this manual to determine acceptable vent and air piping length.

You may use any of the vent/air piping methods covered in this manual. Do not attempt to install the AQUAS Fire Tube boiler using any other means.

You must also install air piping from outside to the boiler air intake adapter unless following the Optional Room Air instructions on page 19 of this manual. The resultant installation is direct vent (sealed combustion).

Air intake/vent connections

1. **Combustion Air Intake Connector** (FIG. 3-6) - Used to provide combustion air directly to the unit from outdoors. On Model 285, a fitting is provided on the unit for final connection. Combustion air piping must be supported per guidelines listed in the National Mechanical Code, Section 305, Table 305.4 or as local codes dictate.
2. **Vent Connector** (FIG.'s 3-7 thru 3-10) - Used to provide a passageway for conveying combustion gases to the outside. A transition fitting is provided on the unit for final connection. Vent piping must be supported per the National Building Code, Section 305, Table 305.4 or as local codes dictate.

Figure 3-6 Near Boiler Air Piping

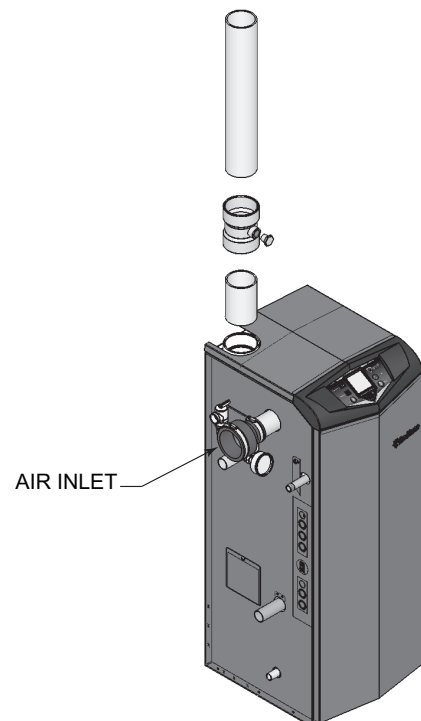

DIR #2000507838 00

3 General venting *(continued)*

Requirements for installation in Canada

1. Installations must be made with a vent pipe system certified to ULC-S636.
2. The first three (3) feet of plastic vent pipe from the appliance flue outlet must be readily accessible for visual inspection.
3. The components of the certified vent system must not be interchanged with other vent systems or unlisted pipe/fittings. For concentric vent installations, the inner vent tube must be replaced with field supplied certified vent material to comply with this requirement.
4. The 3" and 4" Concentric Vent Kit available from Lochinvar (see Section 4 – *Sidewall Termination – Optional Concentric Vent*) and the 3" and 4" Concentric Vent Kit available from IPEX are both approved for use on the AQUAS Fire Tube boiler. Both kits are listed to the ULC-S636 standard for use in Canada.

Sizing

The AQUAS Fire Tube boiler uses model specific combustion air intake and vent piping sizes as detailed in Table 3A below.

Table 3A Air Intake/Vent Piping Sizes

Model	Inlet Diameter	Vent Diameter	Maximum Length
285	3 inches / 4 inches	3 inches / 4 inches	50 feet / 100 feet

NOTICE Increasing or decreasing combustion air or vent piping sizes is not authorized.

NOTICE For Model 285 using 3" venting, the first seven (7) equivalent feet of vent must be CPVC or polypropylene (field supplied). This includes any transition piece used to increase or decrease the vent diameter.

NOTICE The minimum combustion air and vent piping length is 12 equivalent feet.

When determining equivalent combustion air and vent length, add 5 feet for each 90° elbow and 3 feet for each 45° elbow.

EXAMPLE: 20 feet of PVC pipe + (4) 90° elbows + (2) 45° elbows + (1) concentric vent kit (100140480) = 49 equivalent feet of piping.

NOTICE The appliance output rating will reduce by up to 2.3% for each 25 feet of vent length. Consult factory to determine de-rate values.

Table 3B Approved Concentric Vent Systems

Vent Diameter	Vent Supplier	Vent Material	Part Number Lochinvar SAP / Legacy
3 inch	Lochinvar	PVC	100140480
4 inch	Lochinvar	PVC	100140484
3 inch	IPEX	PVC	196006
4 inch	IPEX	PVC	196021
3 inch	IPEX	CPVC	197009
4 inch	IPEX	CPVC	197021

3 General venting

Materials

Air inlet pipe materials:

The air inlet pipe(s) must be sealed. Choose acceptable combustion air inlet pipe materials from the following list:

- PVC, CPVC, Polypropylene or ABS
- Dryer Vent or Sealed Flexible Duct (not recommended for rooftop air inlet)
- Galvanized steel vent pipe with joints and seams sealed as specified in this section.
- Type “B” double-wall vent with joints and seams sealed as specified in this section.
- AL29-4C, stainless steel material to be sealed to specification of its manufacturer.

*Plastic pipe may require an adapter (not provided) to transition between the air inlet connection on the appliance and the plastic air inlet pipe.

WARNING Using air intake materials other than those specified can result in personal injury, death, or property damage.

NOTICE The use of double-wall vent or insulated material for the combustion air inlet pipe is recommended in cold climates to prevent the condensation of airborne moisture in the incoming combustion air.

Sealing of Type “B” double-wall vent material or galvanized vent pipe material used for air inlet piping on a sidewall or vertical rooftop Combustion Air Supply System:

- a. Seal all joints and seams of the air inlet pipe using either Aluminum Foil Duct Tape meeting UL Standard 723 or 181A-P or a high quality UL Listed silicone sealant such as those manufactured by Dow Corning or General Electric.
- b. Do not install seams of vent pipe on the bottom of horizontal runs.
- c. Secure all joints with a minimum of three (3) sheet metal screws or pop rivets. Apply Aluminum Foil Duct Tape or silicone sealant to all screws or rivets installed in the vent pipe.
- d. Ensure that the air inlet pipes are properly supported.

The PVC, CPVC, or ABS air inlet pipe should be cleaned and sealed with the pipe manufacturer’s recommended solvents and standard commercial pipe cement for the material used. The PVC, CPVC, ABS, Dryer Vent, or Flex Duct air inlet pipe should use a silicone sealant to ensure a proper seal at the appliance connection and the air inlet cap connection. Dryer vent or flex duct should use a screw-type clamp to seal the vent to the appliance air inlet and the air inlet cap. Proper sealing of the air inlet pipe ensures that combustion air will be free of contaminants and supplied in proper volume.

Follow the polypropylene manufacturer's instructions when using polypropylene material as an inlet pipe.

When a sidewall or vertical rooftop combustion air supply system is disconnected for any reason, the air inlet pipe must be resealed to ensure that combustion air will be free of contaminants and supplied in proper volume.

DANGER Failure to properly seal all joints and seams as required in the air inlet piping may result in flue gas recirculation, spillage of flue products and carbon monoxide emissions causing severe personal injury or death.

3 General venting *(continued)*

Optional room air

NOTICE

Optional room air is intended for commercial applications. Combustion air piping to the outside is recommended for residential applications.

Commercial applications utilizing the AQUAS Fire Tube boiler may be installed with a single pipe carrying the flue products to the outside while using combustion air from the equipment room. In order to use the room air venting option the following conditions and considerations must be followed.

- The unit **MUST** be installed with the appropriate room air kit (Table 3C).
- The equipment room **MUST** be provided with properly sized openings to assure adequate combustion air. Please refer to instructions provided with the room air kit.
- There will be a noticeable increase in the noise level during normal operation from the inlet air opening.
- Using the room air kit makes the unit vulnerable to combustion air contamination from within the building. Please review Section 1, Prevent Combustion Air Contamination, to ensure proper installation.
- Vent system and terminations must comply with the standard venting instructions set forth in this manual.

WARNING

When utilizing the single pipe method, provisions for combustion and ventilation air must be in accordance with Air for Combustion and Ventilation, of the latest edition of the National Fuel Gas Code, ANSI Z223.1, in Canada, the latest edition of CGA Standard B149 Installation Code for Gas Burning Appliances and Equipment, or applicable provisions of the local building codes.

Air contamination

Pool and laundry products and common household and hobby products often contain fluorine or chlorine compounds. When these chemicals pass through the boiler, they can form strong acids. The acid can eat through the boiler wall, causing serious damage and presenting a possible threat of flue gas spillage or boiler water leakage into the building.

Please read the information given in Table 1B, page 11, listing contaminants and areas likely to contain them. If contaminating chemicals will be present near the location of the boiler combustion air inlet, have your installer pipe the boiler combustion air and vent to another location, per this manual.

WARNING

If the boiler combustion air inlet is located in a laundry room or pool facility, for example, these areas will always contain hazardous contaminants.

WARNING

To prevent the potential of severe personal injury or death, check for areas and products listed in Table 1B, page 11 before installing the boiler or air inlet piping.

If contaminants are found, you **MUST**:

- Remove contaminants permanently.
- OR—
- Relocate air inlet and vent terminations to other areas.

Table 3C *Optional Room Air Kit*

Model	Vent Diameter	Part Number SAP
285	2 inch	100157614

3 General venting

PVC/CPVC

This product has been approved for use with the PVC/CPVC vent materials listed in Table 3D.

Installing vent and air piping

NOTICE Use only cleaners, primers, and solvents that are approved for the materials which are joined together.

NOTICE All PVC vent pipes must be glued, properly supported, and the exhaust must be pitched a minimum of a 1/4 inch per foot back to the boiler (to allow drainage of condensate).

WARNING Insulation should not be used on PVC or CPVC venting materials. The use of insulation will cause increased vent wall temperatures, which could result in vent pipe failure.

1. Work from the boiler to vent or air termination. Do not exceed the lengths given in this manual for the air or vent piping.
2. Cut pipe to the required lengths and deburr the inside and outside of the pipe ends.
3. Chamfer outside of each pipe end to ensure even cement distribution when joining.
4. Clean all pipe ends and fittings using a clean, dry rag. (Moisture will retard curing and dirt or grease will prevent adhesion.)
5. Dry fit vent or air piping to ensure proper fit up before assembling any joint. The pipe should go a third to two-thirds into the fitting to ensure proper sealing after cement is applied.
6. Priming and Cementing:
 - a. Handle fittings and pipes carefully to prevent contamination of surfaces.
 - b. Apply a liberal even coat of primer to the fitting socket and to the pipe end to approximately 1/2" beyond the socket depth.
 - c. Apply a second primer coat to the fitting socket.
 - d. While primer is still wet, apply an even coat of approved cement to the pipe equal to the depth of the fitting socket along with an even coat of approved cement to the fitting socket.
 - e. Apply a second coat of cement to the pipe.
 - f. While the cement is still wet, insert the pipe into the fitting, if possible twist the pipe a 1/4 turn as you insert it. **NOTE:** If voids are present, sufficient cement was not applied and joint could be defective.
 - g. Wipe excess cement from the joint removing ring or beads as it will needlessly soften the pipe.

Table 3D PVC/CPVC Vent Pipe, and Fittings

Approved PVC/CPVC Vent Pipe and Fittings		
Item	Material	Standard
Vent pipe	PVC Schedule 40, 80	ANSI/ASTM D1785
	PVC - DWV	ANSI/ASTM D2665
	CPVC Schedule 40, 80	ANSI/ASTM F441
Vent fittings	PVC Schedule 40	ANSI/ASTM D2466
	PVC Schedule 80	ANSI/ASTM D2467
	CPVC Schedule 40	ANSI/ASTM F438
	CPVC Schedule 80	ANSI/ASTM F439
	PVC - DMV	ANSI/ASTM D2665
Pipe Cement / Primer	PVC	ANSI/ASTM D2564
	CPVC	ANSI/ASTM F493
NOTICE: DO NOT USE CELLULAR (FOAM) CORE PIPE		

NOTE: In Canada, CPVC and PVC vent pipe, fittings, and cement/primer must be ULC-S636 certified.

Figure 3-7 Near Boiler PVC/CPVC Venting

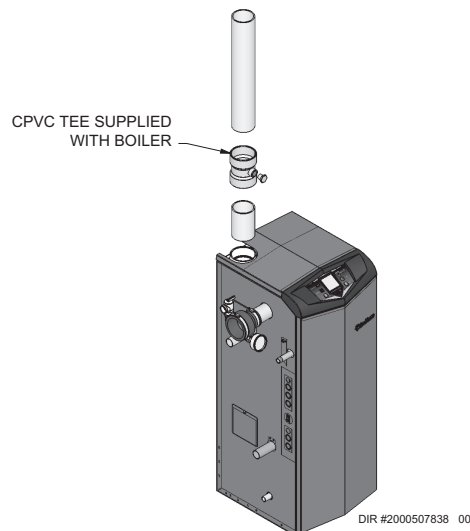

NOTE: CPVC VENT PIPE AND VENT FITTINGS MUST BE USED IN CLOSET AND ALCOVE INSTALLATIONS.

3 General venting *(continued)*

Polypropylene

This product has been approved for use with polypropylene vent with the manufacturers listed in Table 3E.

All terminations must comply with listed options in this manual and be a single-wall vent offering.

For support and special connections required, see the manufacturer's instructions. All vent is to conform to standard diameter and equivalent length requirements established.

When determining equivalent combustion air and vent length for polypropylene single-wall piping:

- 1 foot of Duravent 4 inch single-wall pipe is equivalent to 1.6 feet of piping

Flexible polypropylene

For use of flex pipe, it is recommended to have the vent material in 32°F or higher ambient space before bending at installation. No bends should be made to greater than 45° and ONLY installed in vertical or near vertical installations (FIG. 3-8).

Figure 3-8 Near Boiler Flexible Polypropylene Venting

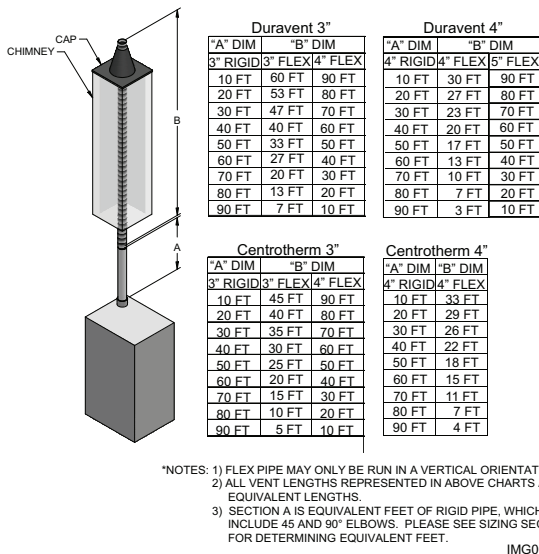

WARNING

Insulation should not be used on polypropylene venting materials. The use of insulation will cause increased vent wall temperatures, which could result in vent pipe failure.

WARNING

Use only the adapters and vent system listed in Table 3E. DO NOT mix vent systems of different types or manufacturers. Failure to comply could result in severe personal injury, death, or substantial property damage.

NOTICE

Installations must comply with applicable national, state, and local codes. For Canadian installation, polypropylene vent must be listed as a ULC-S636 approved system.

NOTICE

Installation of a polypropylene vent system should adhere to the vent manufacturer's installation instructions supplied with the vent system.

Figure 3-9 Near Boiler Polypropylene Venting

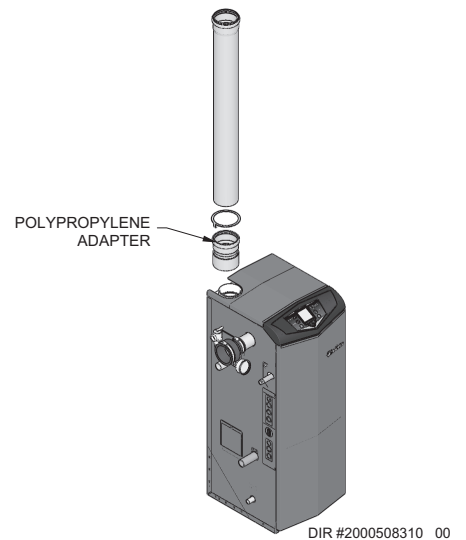

NOTICE

The installer must use a specific vent starter adapter at the flue collar connection. This adapter is supplied by the vent manufacturer to adapt to its vent system. See Table 3G for approved vent adapters. Discard CPVC starter piece.

NOTICE

All vent connections MUST be secured by the vent manufacturer's joint connector (FIG. 3-9).

Table 3E Approved Polypropylene System Adapters

Vent Diameter	Manufacturer	Model	Type	PVC Adapter	Adapter Clamp	Joint Connector	Sidewall Kit
3 inch	DuraVent	PolyPro	Single-Wall / Flex	3PPS-ADL	Included	3PPS-LB	3PPS-HLKL*

*The sidewall kit components are only needed if the sidewall termination assembly is used (see FIG. 4-1B on page 23).

3 General venting

Stainless steel vent

This product has been approved for use with stainless steel using the manufacturers listed in Table 3F.

WARNING Use only the materials, vent systems, and terminations listed in Tables 3F and 3G. DO NOT mix vent systems of different types or manufacturers. Failure to comply could result in severe personal injury, death, or substantial property damage.

NOTICE The installer must use a specific vent starter adapter at the flue collar connection, supplied by the vent manufacturer to adapt to its vent system. See Table 3G for approved vent adapters. Discard CPVC starter piece.

NOTICE Installations must comply with applicable national, state, and local codes. Stainless steel vent systems must be listed as a UL-1738 approved system for the United States and a ULC-S636 approved system for Canada.

NOTICE Installation of a stainless steel vent system should adhere to the stainless steel vent manufacturer's installation instructions supplied with the vent system.

Figure 3-10 Near Boiler Stainless Steel Venting

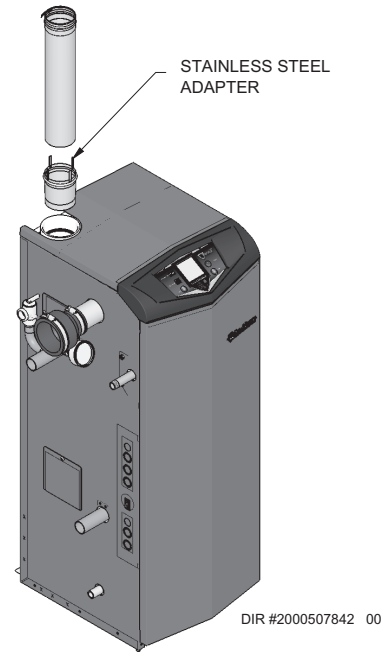

Table 3F Stainless Steel Vent Pipe and Fittings

Approved Stainless Steel Vent Manufacturers	
Make	Model
Dura Vent (M & G Group)	FasNSeal Vent / FasNSeal Flex* Vent
Z-Flex (Nova Flex Group)	Z-Vent
Heat Fab (Selkirk Corporation)	Saf-T Vent

*Use of FasNSeal Flex smooth inner wall vent is to be used in vertical or near vertical sections only, taking precaution to ensure no sagging occurs of the vent system. Connect to the FasNSeal rigid vent using specially designed adapters and sealing method, see manufacturer's instructions.

Table 3G Approved Stainless Steel (S.S.) Venting System Adapters and Terminations

Vent Diameter	Vent Manufacturer	Vent Model	Vent Adapter		Bird Screen	Vent Termination Elbow w/Screen	Rain Cap
			Flue Vent	Air Vent			
3 (4) inch	DuraVent	FasNSeal*	303006	FSA-PVC3	FSBS3(4)	--	FSRC3(4)
3 (4) inch	Heat Fab	Saf-T-Vent	WH0003	9301PVC	93(4)92	93(4)14TERM	53(4)00CI
3(4) inch	Z-Flex	Z-Vent	2SVAKA03	2SVSLA03	2SVSTP03(4)	2SVSTEX03(4)90	2SVSRCF03(4)

*FasNSeal Flex smooth inner wall vent may be used in vertical or near vertical sections. Connect to the FasNSeal rigid vent using specially designed adapters and sealing method. See manufacturer's instructions.

4 Sidewall direct venting

Vent/air termination – sidewall

WARNING Follow instructions below when determining vent location to avoid possibility of severe personal injury, death, or substantial property damage.

WARNING A gas vent extending through an exterior wall shall not terminate adjacent to a wall or below building extensions such as eaves, parapets, balconies, or decks. Failure to comply could result in severe personal injury, death, or substantial property damage.

Determine location

Locate the vent/air terminations using the following guidelines:

1. The total length of piping for vent or air must not exceed the limits given in the General Venting Section on page 17 of this manual.
2. You must consider the surroundings when terminating the vent and air:
 - a. Position the vent termination where vapors will not damage nearby shrubs, plants, or air conditioning equipment or be objectionable.
 - b. The flue products will form a noticeable plume as they condense in cold air. Avoid areas where the plume could obstruct window views.
 - c. Prevailing winds could cause freezing of condensate and water/ice buildup where flue products impinge on building surfaces or plants.
 - d. Avoid possibility of accidental contact of flue products with people or pets.
 - e. Do not locate the terminations where wind eddies could affect performance or cause recirculation, such as inside building corners, near adjacent buildings or surfaces, window wells, stairwells, alcoves, courtyards, or other recessed areas.

WARNING Sidewall vent and air inlet terminations must terminate in the same pressure zone.

- f. Do not terminate above any door or window. Condensate can freeze, causing ice formations.
- g. Locate or guard vent to prevent condensate damage to exterior finishes.

Figure 4-1A PVC/CPVC/ Polypropylene Sidewall Termination of Air and Vent w/Field Supplied Fittings

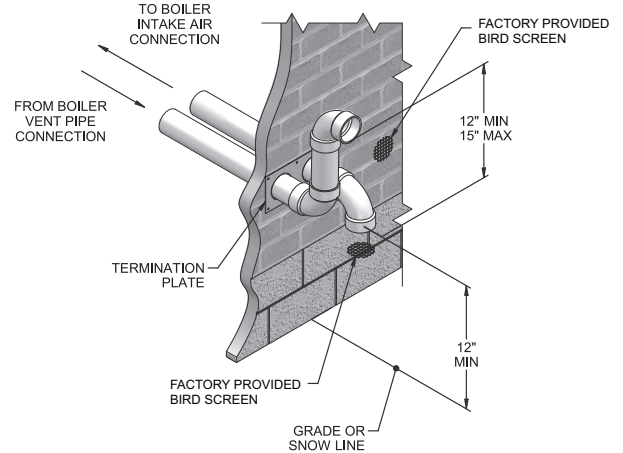

If using the sidewall termination:

3. The air piping must terminate in a down-turned elbow as shown in FIG. 4-1A. This arrangement avoids recirculation of flue products into the combustion air stream.
4. The vent piping must terminate in an elbow pointed outward or away from the air inlet, as shown in FIG. 4-1A.

WARNING Do not exceed the maximum lengths of the outside vent piping shown in FIG. 4-1A. Excessive length exposed to the outside could cause freezing of condensate in the vent pipe, resulting in potential boiler shutdown.

When venting out a sidewall using PVC, CPVC, or Polypropylene vent materials, an optional sidewall vent termination kit can be ordered (reference Table 4A for kit numbers).

Table 4A Alternate Sidewall Vent Kits

Vent Diameter	Supplier	Part Number
3 inch	Lochinvar	100157610
4 inch	Lochinvar	100157611

Figure 4-1B Alternate PVC/CPVC/Polypropylene Sidewall Termination of Air and Vent

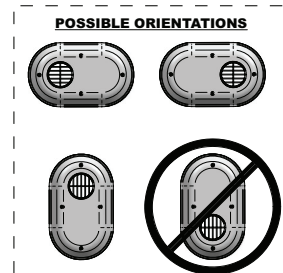
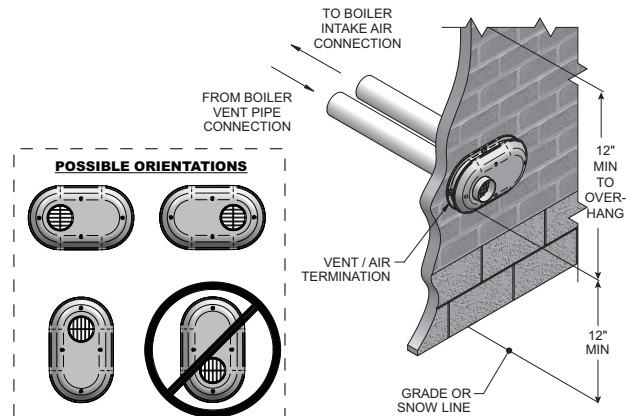

4 Sidewall direct venting

Vent/air termination – sidewall

Figure 4-1C Alternate PVC/CPVC/SS/ Polypropylene Venting Arrangement (if Space Allows) w/Field Supplied Fittings

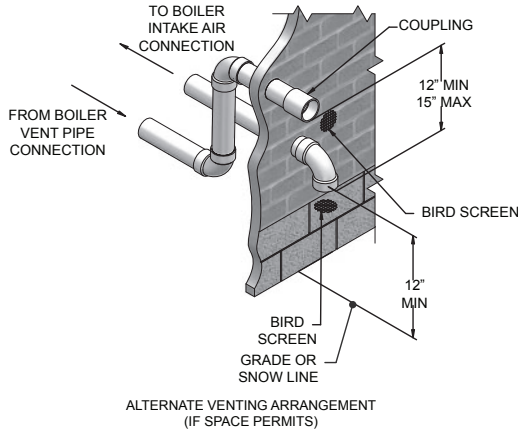
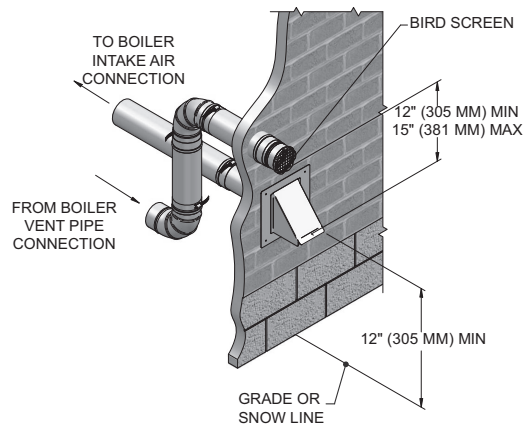

Figure 4-1D Alternate SS Venting Arrangement - Typical Stainless Steel Sidewall Termination of Air and Vent w/Field Supplied Fittings, Utilizing a Hood Intake



5. Maintain clearances as shown in FIG.'s 4-1A thru 4-3B, pages 23 - 25. Also maintain the following:
 - a. Vent must terminate:
 - At least 6 feet from adjacent walls.
 - No closer than 12 inches below roof overhang.
 - At least 7 feet above any public walkway.
 - At least 3 feet above any forced air intake within 10 feet.
 - No closer than 12 inches below or horizontally from any door or window or any other gravity air inlet.
 - b. Air inlet must terminate at least 12 inches above grade or snow line; at least 12 inches below the vent termination; and the vent pipe must not extend more than 24 inches vertically outside the building as shown in FIG. 4-1B. Condensate could freeze and block vent pipe.
 - c. Do not terminate closer than 4 feet horizontally from any electric meter, gas meter, regulator, relief valve, or other equipment. Never terminate above or below any of these within 4 feet horizontally.

6. Locate terminations so they are not likely to be damaged by foreign objects, such as stones or balls, or subject to buildup of leaves or sediment.

Figure 4-2A Clearance to Gravity Air Inlets

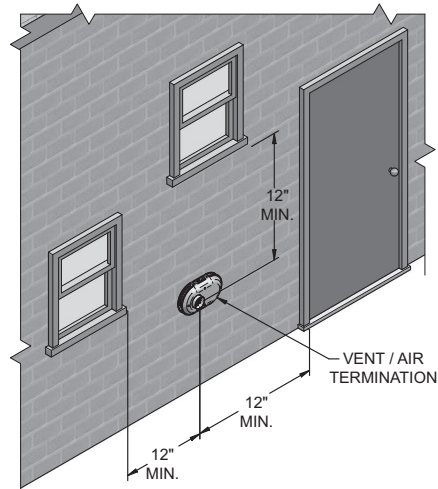

Figure 4-2B Alternate Clearance to Gravity Air Inlets w/ Field Supplied Fittings

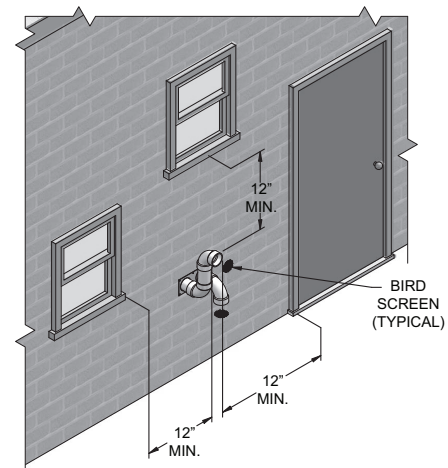
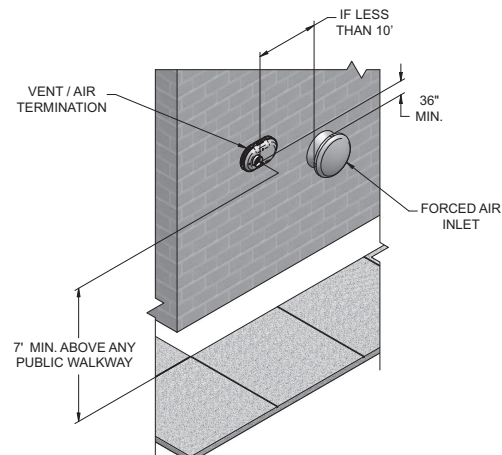
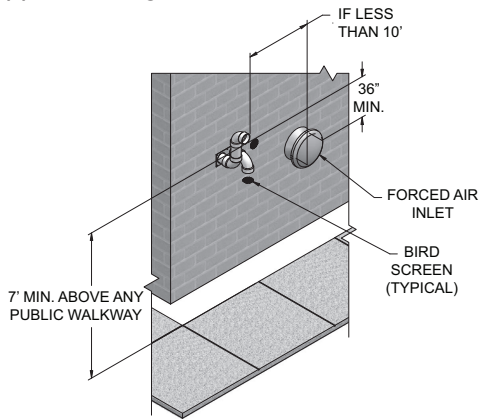

Figure 4-3A Clearance to Forced Air Inlets



4 Sidewall direct venting *(continued)*

Figure 4-3B Alternate Clearance to Forced Air Inlets w/ Field Supplied Fittings



Prepare wall penetrations

1. Use the factory supplied wall plate as a template to locate the vent and air intake holes and mounting holes.

Air pipe penetration:

- a. Cut a hole for the air pipe. Size the air pipe hole as close as desired to the air pipe outside diameter.

Vent pipe penetration:

- a. Cut a hole for the vent pipe. For either combustible or noncombustible construction, size the vent pipe hole with at least a 1/2 inch clearance around the vent pipe outer diameter:
 - 3½ inch hole for 2 inch vent pipe
 - 4½ inch hole for 3 inch vent pipe
 - 5½ inch hole for 4 inch vent pipe

Drill 3/16" diameter holes for inserting the plastic anchors into the wall.

2. For Polypropylene Only: Install the vent and air intake sidewall adapters from Table 3E on page 21 into the vent plate. Slide the sidewall retaining bracket down the sidewall adapters flush to the vent plate (FIG. 4-4B).
3. For PVC/CPVC Only: Install the vent and air intake piping through the wall into the vent plate openings. Use RTV silicone sealant to seal the air pipe. Use the cement/primer listed in Table 3D on page 20 to seal the vent pipe.
4. Mount and secure the vent plate to the wall, using stainless steel screws.
5. Seal all gaps between the pipes and wall. Seal around the plate to the wall assuring no air gaps.
6. Assemble the vent cap to the vent plate (see FIG.'s 4-4A and 4-4B). Insert the stainless steel screws into the vent cap screw hole openings and securely attach the vent cap to the vent plate.
7. Seal all wall cavities.
8. PVC/CPVC terminations are designed to accommodate any wall thickness of standard constructions per the directions found in this manual.

9. Stainless steel terminations are designed to penetrate walls with a thickness up to 9.25 inches of standard construction.

Figure 4-4A PVC/CPVC Sidewall Termination Assembly

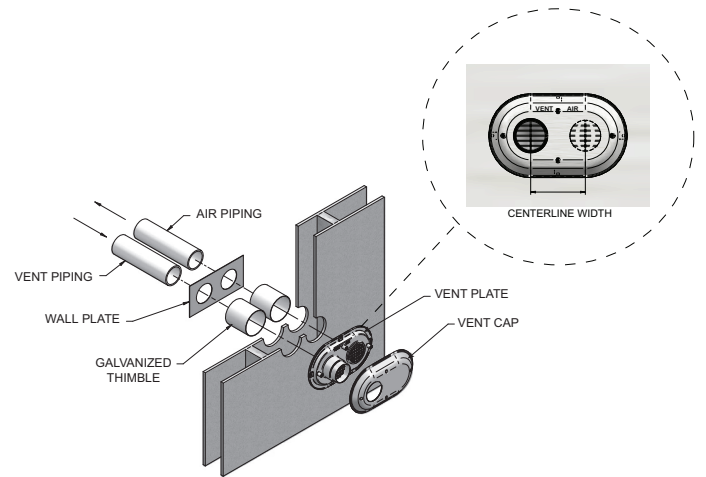
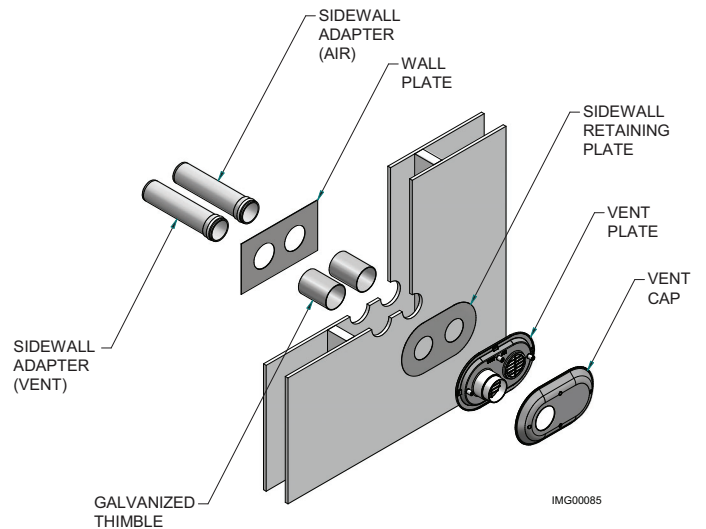

Figure 4-4B Polypropylene Sidewall Termination Assembly



4 Sidewall direct venting

Prepare wall penetrations (Alternate - Field Supplied Option)

1. Air pipe penetration:
 - a. Cut a hole for the air pipe. Size the air pipe hole as close as desired to the air pipe outside diameter.
2. Vent pipe penetration:
 - a. Cut a hole for the vent pipe. For either combustible or noncombustible construction, size the vent pipe hole with at least a 1/2 inch clearance around the vent pipe outer diameter:
 - 3½ inch hole for 2 inch vent pipe
 - 4½ inch hole for 3 inch vent pipe
 - 5½ inch hole for 4 inch vent pipe
 - b. Insert a galvanized metal thimble in the vent pipe hole as shown in FIG. 4-4C.
3. Use a sidewall termination plate as a template for correct location of hole centers.
4. Follow all local codes for isolation of vent pipe when passing through floors or walls.
5. Seal exterior openings thoroughly with exterior caulk.

Figure 4-4C Alternate Sidewall Termination Assembly w/Field Supplied Fittings

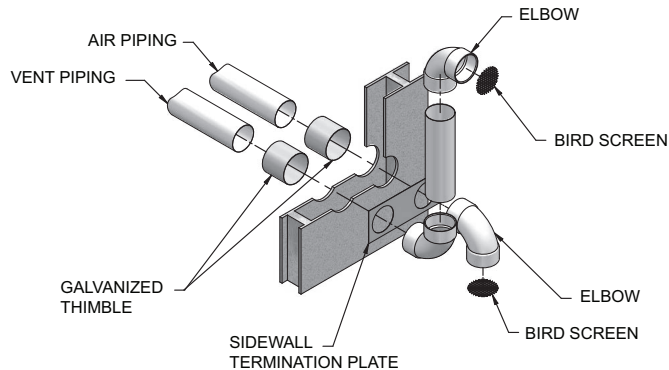

Figure 4-5A Multiple Vent Terminations (must also comply with Figure 4-1A)

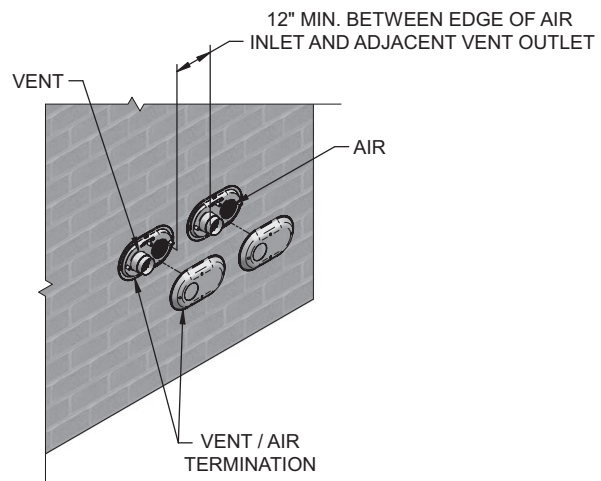
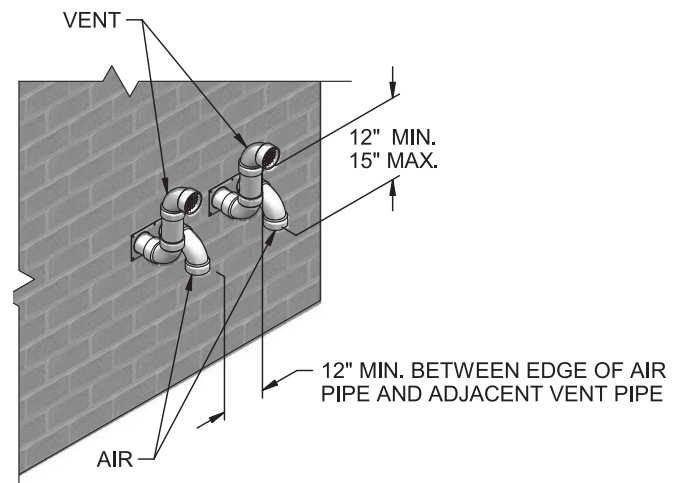

Figure 4-5B Alternate Multiple Vent Terminations w/Field Supplied Fittings (must also comply with Figure 4-1B)



Multiple vent/air terminations

1. When terminating multiple AQUAS Fire Tube boilers terminate each vent/air connection as described in this manual (FIG. 4-5A).

⚠ WARNING All vent pipes and air inlets must terminate at the same height to avoid possibility of severe personal injury, death, or substantial property damage.

2. Place wall penetrations to obtain minimum clearance of 12 inches between edge of air inlet and adjacent vent outlet, as shown in FIG. 4-5A for U.S. installations. For Canadian installations, provide clearances required by CSA B149.1 Installation Code.
3. The air inlet of a AQUAS Fire Tube boiler is part of a direct vent connection. It is not classified as a forced air intake with regard to spacing from adjacent boiler vents.

4 Sidewall direct venting *(continued)*

Sidewall termination – optional concentric vent

Description and usage

Lochinvar offers optional concentric combustion air and vent pipe termination kits (Factory Kit #100140484 for 4" diameter - Model 285). Both combustion air and vent pipes must attach to the termination kit. The termination kits must terminate outside the structure and must be installed as shown below in FIG. 4-6.

The required combustion air and vent pipe materials are listed in Table 3D, on page 20 of this manual.

3. Cut one (1) hole (5 inch diameter for #100140480 and 7 inch diameter for #100140484 installations) into the structure to install the termination kit.
4. Partially assemble the concentric vent termination kit. Clean and cement using the procedures found in these instructions.
 - a. Cement the Y concentric fitting to the larger kit pipe (FIG.'s 4-7 and 4-8).
 - b. Cement the rain cap to the smaller diameter kit pipe (FIG.'s 4-7 and 4-8).

Figure 4-6 Concentric Sidewall Termination

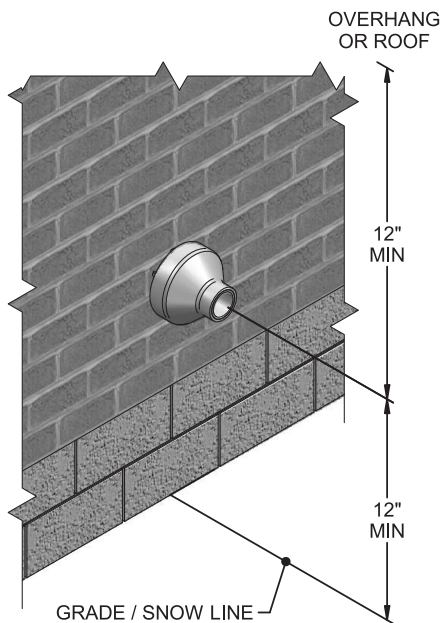

Sidewall termination installation

1. Determine the best location for the termination kit (see FIG. 4-6).
2. Reference the *Determine Location* Section on page 23 of this manual for general termination considerations.

Figure 4-7 Kit Contents_100140480 (reference Table 3B on page 17)

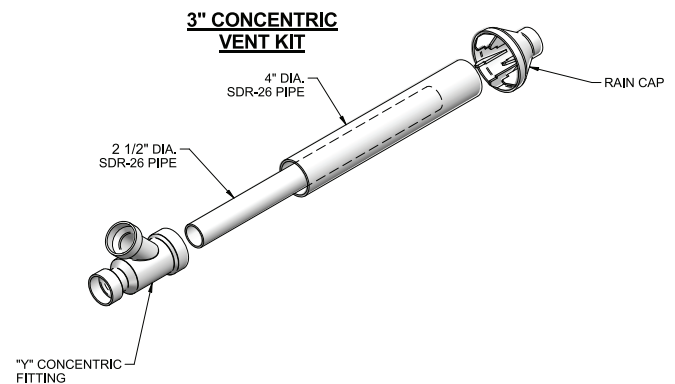
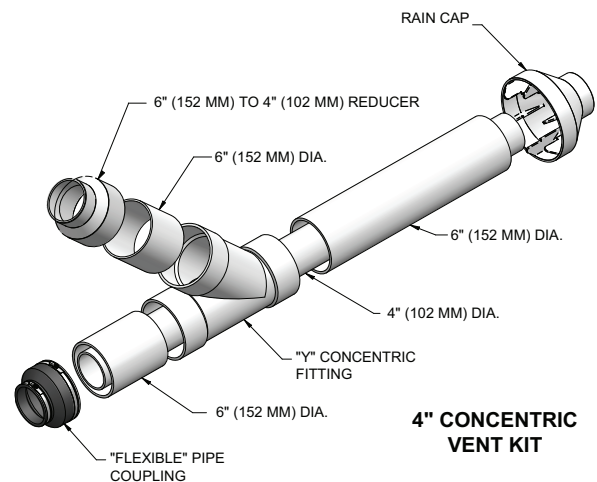

Figure 4-8 Kit Contents_100140484 (reference Table 3B on page 17)



4 Sidewall direct venting

Sidewall termination – optional concentric vent

Figure 4-9 3" Concentric Vent Dimensional Drawing
(reference Table 3B on page 17)

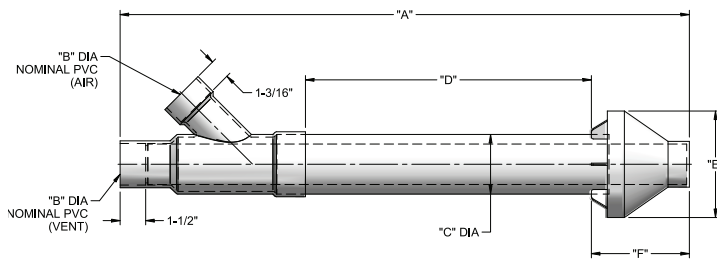

	"A"	"B"	"C"	"D"	"E"	"F"
3" VENT KIT	38-7/8"	3"	4-1/2"	21-1/8"	7-3/8"	6-1/2"

Figure 4-10 4" Concentric Vent Dimensional Drawing
(reference Table 3B on page 17)

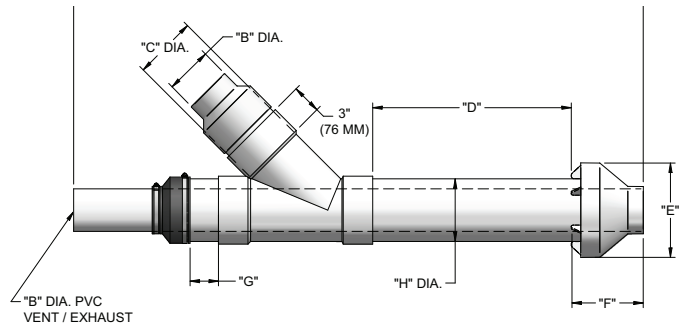

A	B	C	D	E	F	G	H
60"	4"	6"	21 1/8"	10"	7 5/8"	3"	6 5/8"
(1524 MM)	(102 MM)	(152 MM)	(537 MM)	(254 MM)	(194 MM)	(76 MM)	(168 MM)

NOTICE Instead of cementing the smaller pipe to the rain cap, a field-supplied stainless steel screw may be used to secure the two (2) components together when field disassembly is desired for cleaning (see FIG. 4-11).

WARNING When using the alternate screw assembly method, drill a clearance hole in the rain cap and a pilot hole in the vent pipe for the screw size being used. Failure to drill adequate holes may cause cracking of PVC components, allowing combustion products to be recirculated. Failure to follow this warning could result in personal injury or death.

WARNING Do not operate the appliance with the rain cap removed or recirculation of combustion products may occur. Water may also collect inside the larger combustion air pipe and flow to the burner enclosure. Failure to follow this warning could result in product damage or improper operation, personal injury, or death.

5. Install the Y concentric fitting and pipe assembly through the structure's hole from an inside wall.

NOTICE Do not allow insulation or other materials to accumulate inside the pipe assembly when installing through the hole.

6. Install the rain cap and small diameter pipe assembly into the Y concentric fitting and large pipe assembly from an outside wall. Ensure small diameter pipe is bottomed and cemented in the Y concentric fitting for #100140480 installations and fastened tightly into the rubber adapter for #100140484 installations.

7. Secure the assembly to the structure as shown in FIG. 4-12 using field-supplied metal strapping or equivalent support material.

NOTICE Ensure termination location clearance dimensions are as shown in FIG. 4-6.

NOTICE If assembly needs to be extended to allow sidewall thickness requirement, the two (2) pipes supplied in the kit may be replaced by using the same diameter, field-supplied SDR-26 PVC (D2241) pipe for #100140480 and standard schedule 40 PVC for #100140484. Do not extend dimension D* more than 60 inches (see FIG.'s 4-9 and 4-10).

NOTICE If assembly depth needs to be reduced, dimension D can be as short as possible.

Figure 4-11 Rain Cap to Vent Pipe Alternate Assembly

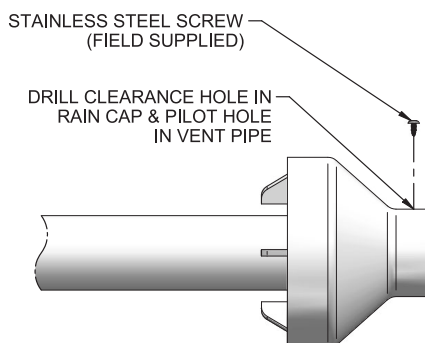

4 Sidewall direct venting *(continued)*

Sidewall termination – optional concentric vent

Figure 4-12 Concentric Vent Sidewall Attachment

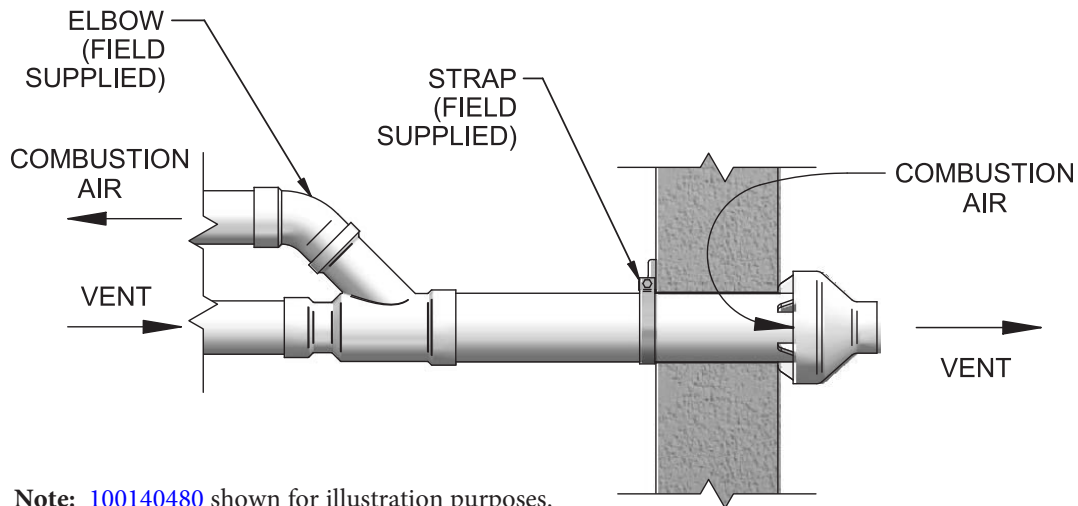

Note: 100140480 shown for illustration purposes.

CAUTION

DO NOT use field-supplied couplings to extend pipes. Airflow restriction will occur and may cause intermittent operation.

8. Cement appliance combustion air and vent pipes to the concentric vent termination assembly. See FIG. 4-12 for proper pipe attachment.
9. Operate the appliance one (1) heat cycle to ensure combustion air and vent pipes are properly connected to the concentric vent termination connections.

Multi-venting sidewall terminations

When two (2) or more direct vent appliances are vented near each other, each appliance must be individually vented (see FIG. 4-13). NEVER common vent or breach vent this appliance. When two (2) or more direct vent appliances are vented near each other, two (2) vent terminations may be installed as shown in FIG. 4-13. It is important that vent terminations be made as shown to avoid recirculation of flue gases.

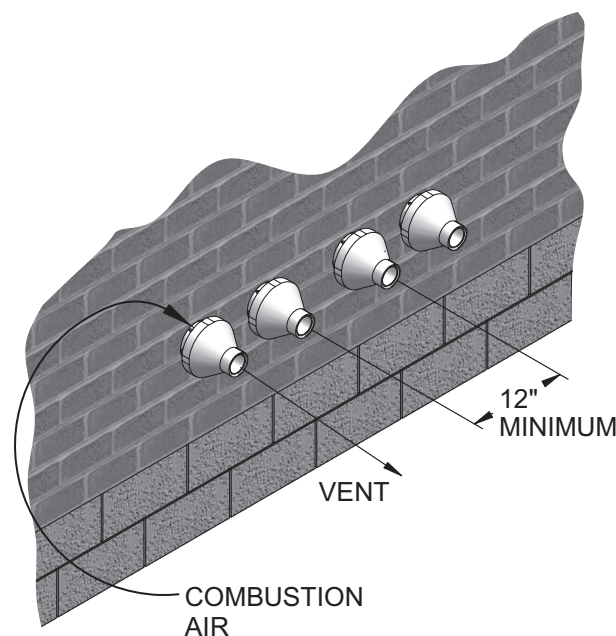

Figure 4-13 Concentric Vent and Combustion Air Termination

5 Vertical direct venting

Vent/air termination – vertical

WARNING Follow instructions below when determining vent location to avoid possibility of severe personal injury, death, or substantial property damage.

Determine location

Locate the vent/air terminations using the following guidelines:

1. The total length of piping for vent or air must not exceed the limits given in the General Venting Section on page 17 of this manual.
2. Prepare the vent termination and the air termination elbow (FIG. 5-1A) by inserting bird screens. Bird screens should be obtained locally.
3. The vent must terminate at least 3 feet above the highest place in which the vent penetrates the roof and at least 2 feet above any part of a building within 10 horizontal feet.
4. The air piping must terminate in a down-turned 180° return pipe no further than 2 feet from the center of the vent pipe. This placement avoids recirculation of flue products into the combustion air stream.
5. The vent piping must terminate in an up-turned coupling as shown in FIG. 5-1A. The top of the coupling must be at least 1 foot above the air intake. When the vent termination uses a rain cap as illustrated in FIG. 5-1B maintain at least 36" (914 mm) above the air inlet. The air inlet pipe and vent pipe can be located in any desired position on the roof, but must always be no further than 2 feet (.6 m) apart and with the vent termination at least 1 foot for PVC and 3 feet for stainless steel, above the air intake.
6. Maintain the required dimensions of the finished termination piping as shown in FIG. 5-1A.
7. Do not extend exposed vent pipe outside of building more than shown in this document. Condensate could freeze and block vent pipe.

WARNING Rooftop vent and air inlet terminations must terminate in the same pressure zone, unless vertical vent sidewall air is set up as shown in the General Venting - Vertical Vent, Sidewall Air Section.

Figure 5-1A PVC/CPVC/Polypropylene Vertical Termination of Air and Vent

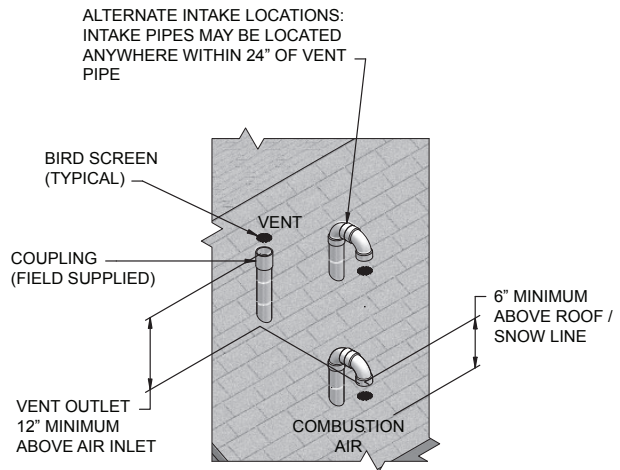
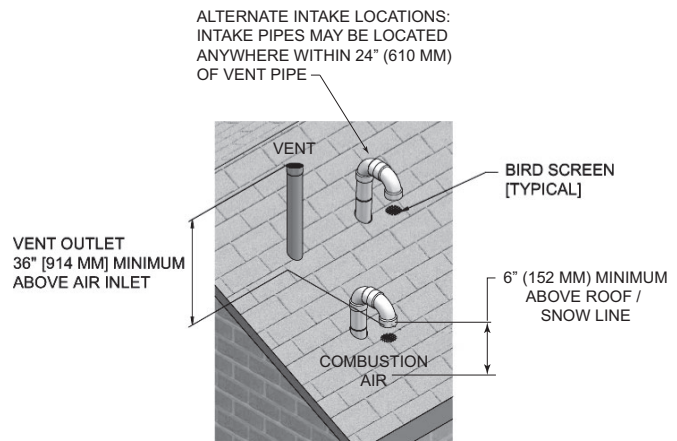

Figure 5-1B Stainless Steel Vertical Termination of Air and Vent



8. Locate terminations so they are not likely to be damaged by foreign objects, such as stones or balls, or subject to buildup of leaves or sediment.

5 Vertical direct venting *(continued)*

Vent/air termination – vertical

Prepare roof penetrations

1. Air pipe penetration:
 - a. Cut a hole for the air pipe. Size the air pipe hole as close as desired to the air pipe outside diameter.
2. Vent pipe penetration:
 - a. Cut a hole for the vent pipe. For either combustible or noncombustible construction, size the vent pipe hole with at least a 1/2 inch clearance around the vent pipe outer diameter:
 - 3½ inch hole for 2 inch vent pipe
 - 4½ inch hole for 3 inch vent pipe
 - 5½ inch hole for 4 inch vent pipe
 - b. Insert a galvanized metal thimble in the vent pipe hole.
3. Space the air and vent holes to provide the minimum spacing shown in FIG. 5-1A, page 30.
4. Follow all local codes for isolation of vent pipe when passing through floors, ceilings, and roofs.
5. Provide flashing and sealing boots sized for the vent pipe and air pipe.

Multiple vent/air terminations

1. When terminating multiple AQUAS Fire Tube boilers, terminate each vent/air connection as described in this manual (FIG. 5-2).

- ⚠ WARNING** Terminate all vent pipes at the same height and all air pipes at the same height to avoid possibility of severe personal injury, death, or substantial property damage.
2. Place roof penetrations to obtain minimum clearance of 12 inches between edge of air intake elbow and adjacent vent pipe of another boiler for U.S. installations (see FIG. 5-2). For Canadian installations, provide clearances required by CSA B149.1 Installation Code.
 3. The air inlet of a AQUAS Fire Tube boiler is part of a direct vent connection. It is not classified as a forced air intake with regard to spacing from adjacent boiler vents.

Figure 5-2 Vertical Terminations with Multiple Boilers

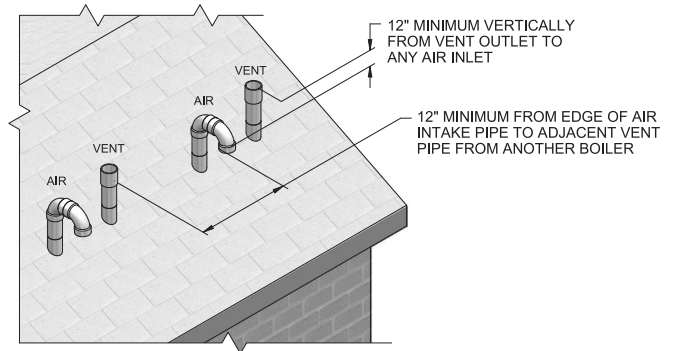
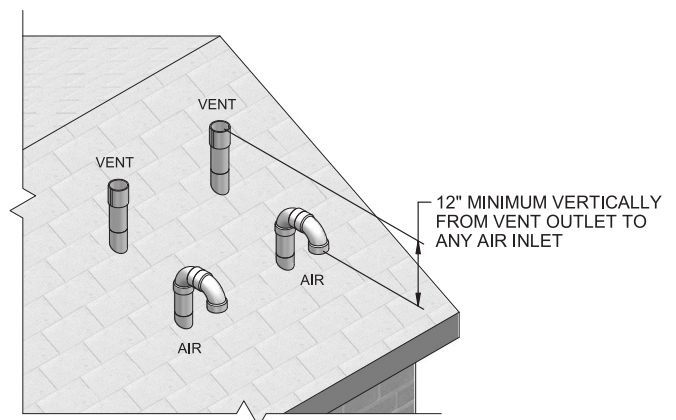

Figure 5-3 Alternate Vertical Terminations with Multiple Boilers



5 Vertical direct venting

Vertical termination – optional concentric vent

Description and usage

Lochinvar offers an optional concentric combustion air and vent pipe termination kit. Both combustion air and vent pipes must attach to the termination kit. The termination kit must terminate outside the structure and must be installed as shown in FIG. 5-4.

Field supplied pipe and fittings are required to complete the installation.

The required combustion vent pipe and fittings are listed in Table 3D, on page 20 of this manual.

Vertical termination installation

1. See Section 5, Vertical Direct Venting - Determine Location (where applicable) (FIG. 5-1A).

Figure 5-4 Concentric Vertical Termination

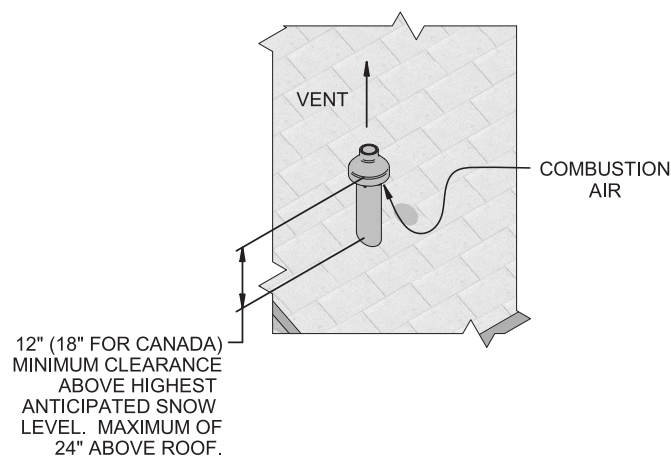

Figure 5-5 Do Not Install U-Bend to Rain Cap



2. Cut one (1) hole (7 inch diameter for #100140484 installations) into the structure to install the termination kit.
3. Partially assemble the concentric vent termination kit. Clean and cement following the cleaning procedures in these instructions.
 - a. Cement the Y concentric fitting to the larger diameter kit pipe (see FIG.'s 4-7 and 4-8, page 27).
 - b. Cement rain cap to the smaller diameter kit pipe (see FIG.'s 4-7 and 4-8, page 27).

NOTICE

Instead of cementing the smaller pipe to the rain cap, a field supplied stainless steel screw may be used to secure the two (2) components together when field disassembly is desired for cleaning (see FIG. 4-11, page 28).

WARNING

When using the alternate screw assembly method, drill a clearance hole in the rain cap and a pilot hole in the vent pipe for the screw size being used. Failure to drill adequate holes may cause cracking of PVC components, allowing combustion products to be recirculated. Failure to follow this warning could result in personal injury or death.

5 Vertical direct venting *(continued)*

Vertical termination – optional concentric vent

WARNING Do not operate the appliance with the rain cap removed or recirculation of combustion products may occur. Water may also collect inside the larger combustion air pipe and flow to the burner enclosure. Failure to follow this warning could result in product damage or improper operation, personal injury, or death.

4. Install the Y concentric fitting pipe assembly up through the structure's hole and field supplied roof boot/flashing.

NOTICE Do not allow insulation or other materials to accumulate inside the pipe assembly when installing through the hole.

5. Secure the assembly to the roof structure as shown below in FIG. 5-6 using field-supplied metal strapping or equivalent support material.

Figure 5-6 Concentric Vent Roof Installation

Note: 100140480 shown for illustration purposes.

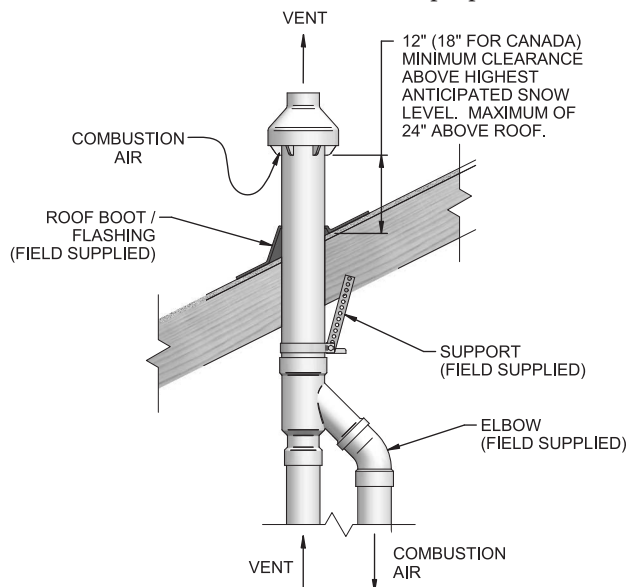

NOTICE Ensure termination height is above the roof surface or anticipated snow level (12 inches in U.S.A. or 18 inches in Canada) as shown in FIG. 5-4, page 30.

NOTICE If assembly is too short to meet height requirement, the two (2) pipes supplied in the kit may be replaced by using the same diameter, field supplied SDR-26 PVC (D2241) pipe for 100140480 and standard schedule 40 PVC for 100140484. Do not extend dimension D* more than 60 inches (see FIG.'s 4-9 and 4-10, page 28).

CAUTION DO NOT use field-supplied couplings to extend pipes. Airflow restriction will occur.

6. Install the rain cap and the small diameter pipe assembly into the roof penetration assembly. Ensure the small diameter pipe is cemented and bottomed in the Y concentric fitting for #100140480 installations and fastened tightly into the rubber adapter for #100140484 installations.
7. Cement the appliance combustion air and vent pipes to the concentric vent termination assembly. See FIG. 5-6 for proper pipe attachment.
8. Operate the appliance through one (1) heat cycle to ensure combustion air and vent pipes are properly connected to the concentric vent termination connections.

Multi-venting vertical terminations

When two (2) or more direct vent appliances are vented near each other, each appliance must be individually vented (see FIG. 5-7). NEVER common vent or breach vent this appliance. When two (2) or more direct vent appliances are vented near each other, two (2) vent terminations may be installed as shown in FIG. 5-7. It is important that vent terminations be made as shown to avoid recirculation of flue gases.

Figure 5-7 Concentric Vent and Combustion Air Vertical Termination

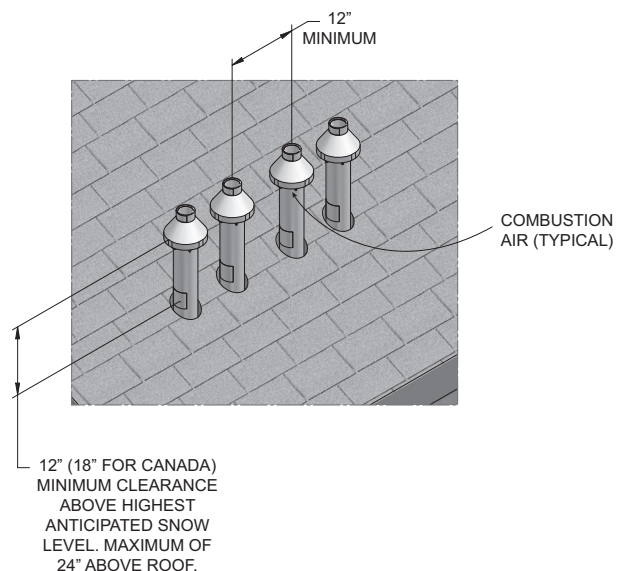

5 Vertical direct venting

Alternate vertical concentric venting

This appliance may be installed with a concentric vent arrangement where the vent pipe is routed through an existing unused venting system; or by using the existing unused venting system as a chase for vent and combustion air routing.

Concentric Venting Arrangement

The venting is to be vertical through the roof. The annular space between the O.D. of the vent pipe and the I.D. of the existing unused venting system is utilized for the combustion air source.

The minimum size of the existing vent system required to achieve enough annular space for combustion air can be found in Table 5A below.

The upper and lower termination as well as any other unsealed joints in the existing vent system **must be sealed** to ensure that all combustion air is drawn from under the vent cap as shown in FIG.'s 5-8 and 5-9.

Approved venting materials must be used as specified in Table 3D on page 20.

Follow all vent / air termination and clearance requirements per this section to the appropriate example. Installation must comply with local requirements and with the National Fuel Gas Code.

The maximum allowable equivalent vent and air intake lengths for this venting arrangement are to be determined from the General Venting Section.

If an existing unused venting system is converted for use with this method of concentric venting, the installer must ensure that the existing venting system is clean and free from particulate contamination that will harm this appliance and cause increased nuisance calls or maintenance. See Table 1B on page 11 for a list of corrosive contaminants and sources.

Two example scenarios of a concentric venting arrangement are shown for illustrative purposes in FIG.'s 5-8 and 5-9.

Table 5A Alternate Vertical Concentric Vent / Chase Sizes

Vent / Air Inlet Size	Minimum Existing Vent / Chase Size
3"	5"
4"	7"

Figure 5-8 Concentric Vent Example 1

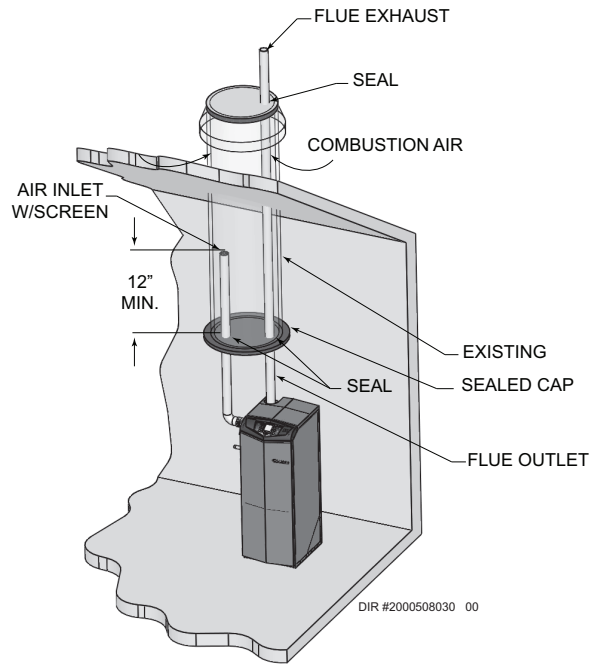

*For concept illustration only. Individual installations may vary due to job site specific equipment.

Figure 5-9 Concentric Vent Example 2

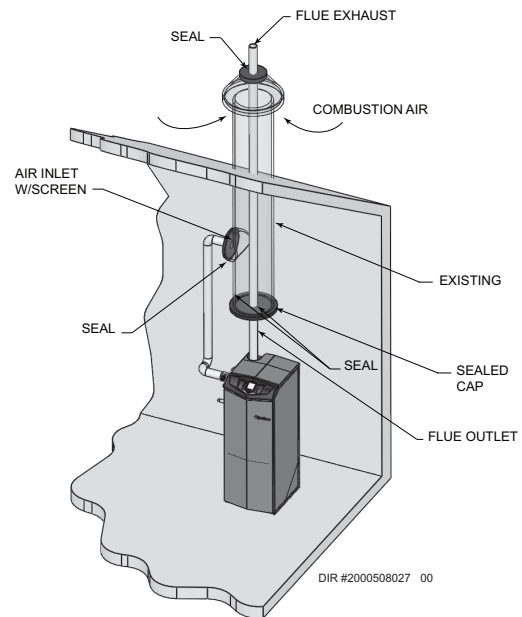

*For concept illustration only. Individual installations may vary due to job site specific equipment.

5 Vertical direct venting *(continued)*

Existing vent as a chase

Follow all existing termination and clearance requirements and allowable pipe lengths. Use only approved venting materials listed in the General Venting Section of this manual.

Figure 5-10 Existing Vent as a Chase

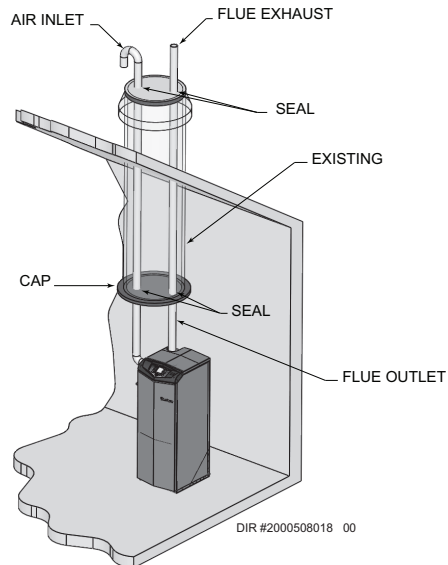

*For concept illustration only. Individual installations may vary due to job site specific equipment.

6 Hydronic piping

Installation Instructions

To achieve the optimum operating efficiency of your AQUAS it is recommended that you keep the pool water flow of each appliance within plus or minus five gallons per minute of the recommended flow as stated in Table 6A. Low flow through the indirect heat exchanger will result in elevated temperatures supplied to the pool.

Table 6A Recommended Water Flow

MODEL	RECOMMENDED SYSTEM WATER FLOW	CONNECTION SIZE
285	70 GPM	2.5"

Piping

Pool / spa connections to the indirect heat exchanger are SCH 80 CPVC glue fittings. The connections from the field loop to the heat exchanger may be done in CPVC or PVC pipe as follows:

- Use cement on the connections so they are rated for CPVC pipe and have enough body to hold the connection.
- To make the connection, apply glue to both the CPVC flange and the section of pipe.
- Insert the pipe into the flange until it reaches the bottom of the flange.
- Turn the pipe a half turn in the socket to ensure that a proper seal is made.

Pool water is designed to flow from right to left standing in front of the boiler (factory installed sensor is on the inlet side of the indirect heat exchanger, see FIG. 6-4).

The supply and return water piping to the indirect heat exchanger shall be no smaller than 2" for model 285.

Throttling Valve

A ΔT of 8° - 10°F across the indirect heat exchanger is recommended. Throttling valves are used to set the flow through the indirect heat exchanger (standard gate valves are acceptable).

6 Hydronic piping *(continued)*

The system can be installed in either a Full Flow or Diverted Flow orientation:

Full Flow *(reference FIG. 6-3)*

If the total system flow of the swimming pool or spa system is within five gallons per minute of the recommended system water flow as shown in Table 6A on page 36, this type of system is recommended.

Diverted Flow *(reference FIG. 6-4)*

Criteria for installing a diverted flow system is as follows:

- If the total system flow is greater than the amount required by the indirect heat exchanger.
- Installations with temperatures in excess of 95°F. This is necessary so the pool high limit will not trip. No water should enter the pool / spa in excess of 115°F. If the heat exchanger pool outlet is in excess of 115°F the water must be tempered down.
- Multiple unit installation.

Example: Total system flow is 500 gallons per minute (GPM). If two AQUAS Pool Packages (800,000 Btu/hr) were installed, each of the pool packages would require 202 GPM for a total of 404 GPM of the pool water being diverted through the indirect heat exchangers while the other 96 GPM would be diverted back to the pool.

Auxiliary Mixed Water Limit Control

Ensure that the auxiliary 115°F mixed water limit control is installed in the filter system piping. Install the auxiliary limit a minimum of three feet downstream from the point where the heated water from the indirect heat exchanger is added to the filtration system (see FIG. 6-4). If the water leaving the heat exchanger is in excess of 115°F a bypass must be installed to temper the water below 115°F before re-entering the pool/spa.

If the total system flow of the swimming pool or spa system is within five gallons per minute of the recommended system water

The limit will be mounted in a 3/8" NPT tapped fitting installed in the filtration system piping or it may be installed directly into a tapped opening in the PVC filter system piping. Turn off the filter system pump when installing the auxiliary limit in the filtration system piping. Tapped openings can be added to the PVC pipe by first drilling 9/16" pilot holes in the PVC pipe at least three feet downstream of the point where the heated water from the indirect heat exchanger is added to the filter piping. The drilled pilot holes can now be carefully threaded with a 3/8" NPT tap. After the pipe threads have been cut into the PVC pipe wall the limit and bulbwell can be inserted into the tapped openings.

Apply a small amount of a high quality RTV silicone sealant to the threads to prevent leaks and install the limit and bulbwell into the threaded opening in the pipe. Install the limit control and bulbwell and tighten to seal. Do not over tighten either part into the threaded opening in the PVC pipe. Over tightening can damage the parts and/or strip the threads cut into the plastic pipe. Wire the 115°F limit into the boiler control circuit as shown in FIG. 8-3 on page 51. If additional wire length is needed, use 18 gauge wire for distances up to 30 feet. For longer distances, size the wire per Table 6B.

Table 6B Remote Wire Connection

WIRE GAUGE	MAXIMUM ALLOWABLE LENGTH
12 GA	100 ft.
14 GA	75 ft.
16 GA	50 ft.
18 GA	30 ft.

Figure 6-1 Pumping and Filtration Equipment

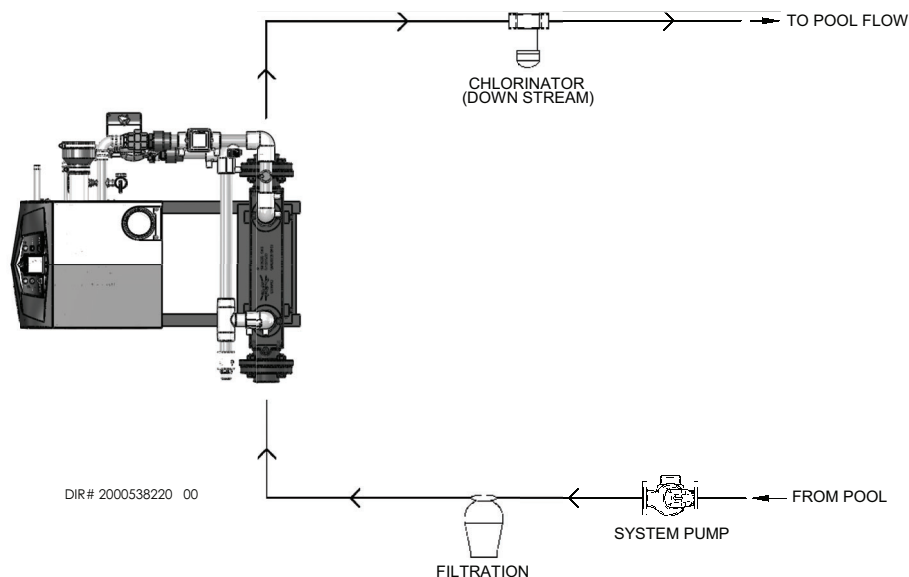

6 Hydronic piping

Indirect Heat Exchanger Installation Instructions

Heat exchangers should be installed downstream of the pumping and filtration equipment (reference FIG. 6-1).

Makeup Water Assembly

NOTICE

In the following steps, a backup wrench is necessary to properly attach the makeup water assembly.

1. Attach the brass reducer tee to the expansion tank as shown in FIG. 6-2.
2. Attach the assembly to the AQUAS system.
3. Attach the brass nipple to the brass tee as shown in FIG. 6-2.
4. Attach the makeup water fill valve to the open end of the brass nipple.

Figure 6-2 Connecting the Makeup Water Assembly

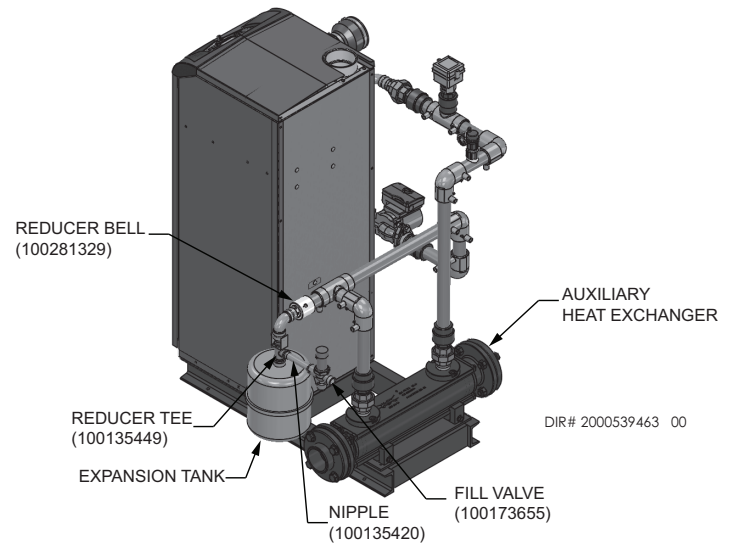
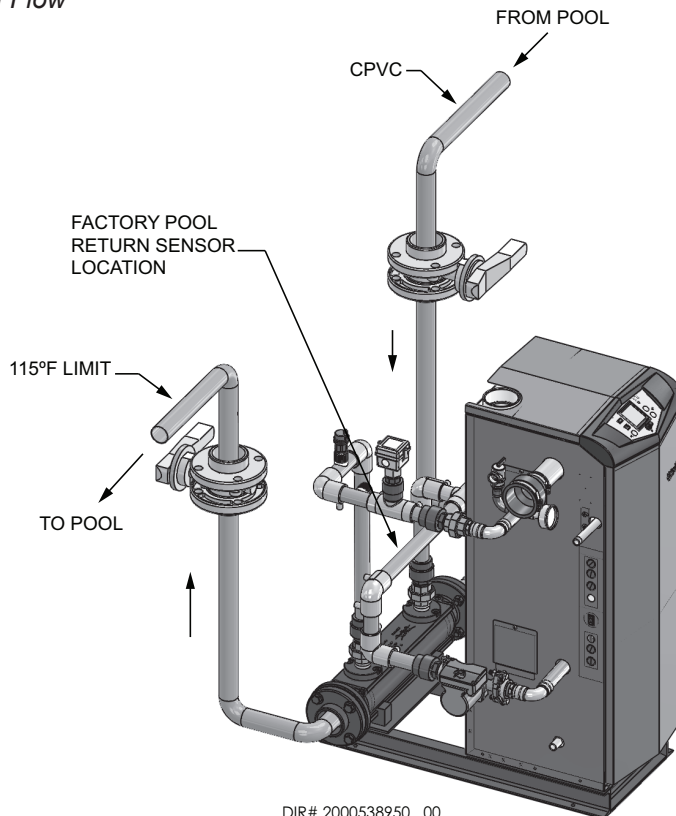

Figure 6-3 Full Flow



NOTICE

Please note that these illustrations are meant to show system piping concept only, the installer is responsible for all equipment and detailing required by local codes.

6 Hydronic piping *(continued)*

Figure 6-4 Bypass (if flow is greater than required by heat exchanger)

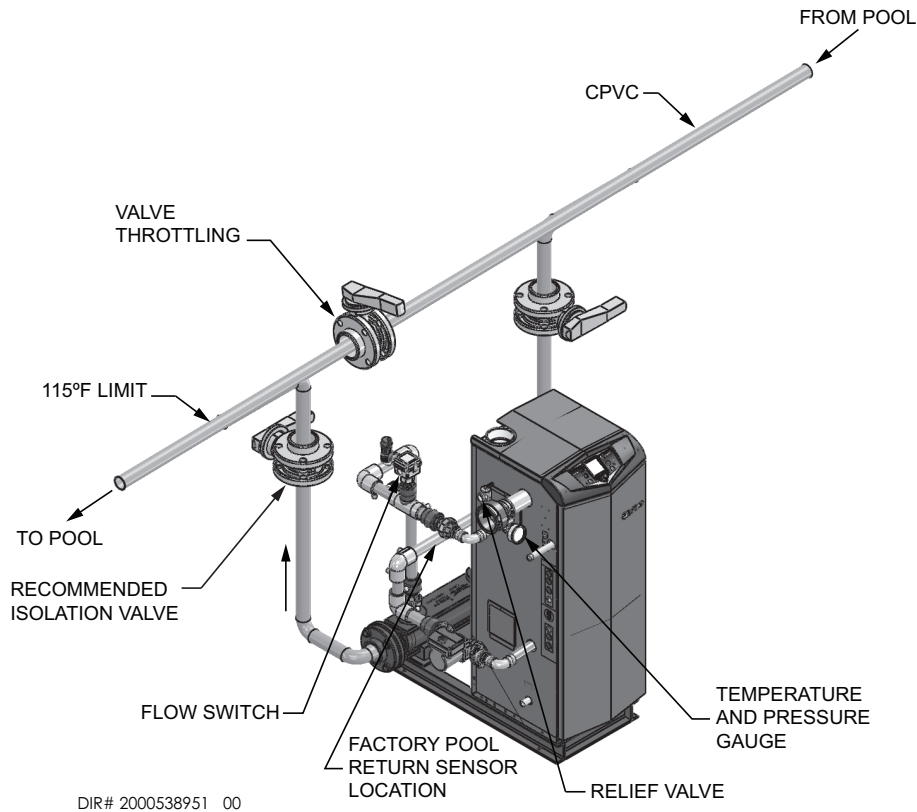

NOTICE

Adjust valves to provide suggested flow per Table 6A on page 36.

AQUAS Fire Tube Pool Setup

To access the Installer setting press and hold the Menu/Exit key until it requires the installer's code. Proceed and enter #5309 (reference Table 11A on page 69).

NOTE: NA = No adjustment necessary.

Standalone Operation

Temperature Settings

1. SH1 Set Point (Pool Temperature)
2. Minimum SH Set Point (Pool Temperature Minimum)
3. Maximum SH Set Point (Factory Set 104°F)
4. SH1 Offset (2°F Minimum) number of degrees above the set point the boiler will turn off.
5. SH1 differential (4°F Minimum) number of degrees below the turn off temperature the boiler must see before the boiler will turn on.

Example: Set Point 78°F
 Offset = 2 Boiler OFF at 80°F
 Differential = 4 Boiler ON at 76°F

6 Hydronic piping

Auxiliary Heat Exchanger / Domestic Hot Water

This system received factory installed auxiliary tapings for Domestic Hot Water (DHW) or Spa operation. The heat exchanger kits listed in Tables 6C and 6D include all the necessary parts to install the auxiliary heat exchanger in the field. Piping is not included with this package and should be field-supplied. Flow charts are provided in FIG. 6-6 so that a pump may be properly sized for the system. Use the connection points indicated for DHW operation on the boiler. Refer to Table 6C for boiler flow requirements. Reference Fig. 6-5 for an auxiliary piping illustration.

Table 6C Spa Parameters

Model	285
BTU/hr Input	80,000
Min HEX Flow (GPM)	21
DHW/Spa Connection (Inlet & Outlet)	1.5"

Table 6D Heat Exchanger Data

Heat Exchanger	Btu/hr Input Range		Shell Connection	Boiler Flow	Pool Connection	Tube Sheet	
	MIN	MAX				Min	Max
100061682	80,000	130,000	1"	21	1.5"	25	66

DHW/Spa (Domestic Hot Water) Thermostat

Connect the storage indirect water heater (DHW) thermostat (FIG. 8-3, page 51) to the DHW thermostat terminals on the connection board following the loop diagram. Failure to do so may result in premature failure in DHW/Spa system. When the tank sensor is connected the thermostat is ignored (see *DHW/Spa tank sensor*).

DHW/Spa tank sensor

By installing a tank/spa sensor, the SMART SYSTEM control can perform the tank thermostat function. The SMART SYSTEM control automatically detects the presence of this sensor and generates a DHW/Spa call for heat when the tank temperature drops 2°F (1°C) below the tank setpoint. The SMART SYSTEM control then finishes the call for heat when the tank temperature reaches the tank/spa setpoint. The tank sensor included with the Squire® indirect DHW tanks (100170544) and 100170581, which is included with the auxiliary heat exchanger are the only sensors suitable for use with the SMART SYSTEM control. Connect the sensor leads to the tank sensor terminals on the low voltage connection board (FIG. 8-3).

WARNING

Failure to use the correct sensor may result in the tank temperature being either above or below the setpoint. If thermistors are not compatible with the indirect tank/spa, a tank thermostat can be used to control the boiler. The tank thermostat should be installed per the manufacturer’s instructions and wired to the DHW/Spa thermostat terminals on the low voltage connection board.

Spa sensor

The spa sensor (100170581) must be looped with the 115°F Pool Sensor (100073321) on the low voltage connection board (FIG. 8-3). On the low voltage connection board use terminals 21 & 22 for Pool operation and terminals 26 & 27 (Tank Sensor) for Spa operation.

Start-up

Set domestic hot water (DHW/Spa) operation

Verify DHW/Spa mode

There are two modes of operation for DHW. In “Normal Mode” when a DHW/Spa demand begins, the control will start the DHW/Spa pump, turn off the boiler pump (if running) and modulate to bring the outlet temperature to the DHW/Spa boiler set point. The maximum firing rate may be limited in this mode if desired.

In “Zone Mode” it is assumed that the indirect DHW/Spa tank is piped as a zone on the primary loop. When a DHW/Spa demand begins, the control will turn on the DHW/Spa pump output and raise the system temperature set point to the DHW/Spa boiler set point (if higher). The boiler pump will be turned on. The system pump may be forced on, forced off, or unchanged depending on the system pump mode selected. See FIG. 6-6 for flow chart and pump sizing information. Refer to the Knight Fire Tube Service Manual for additional information.

6 Hydronic piping *(continued)*

Set DHW/Spa boiler target temperature

When in the DHW/Spa Mode, the control will modulate to maintain the boiler outlet temperature or system supply temperature to a set point. This set point is factory-set at 104°F. If a different set point is desired, the appropriate parameter in the control must be changed. See the Knight Fire Tube Service Manual for additional information.

Set maximum DHW/Spa fan speed

If the rated input of the indirect tank is less than the maximum output of the boiler, change the maximum DHW/Spa fan speed setting to limit the boiler output accordingly. Refer to the Knight Fire Tube Service Manual for additional information.

Figure 6-5 Auxiliary Piping for Spa

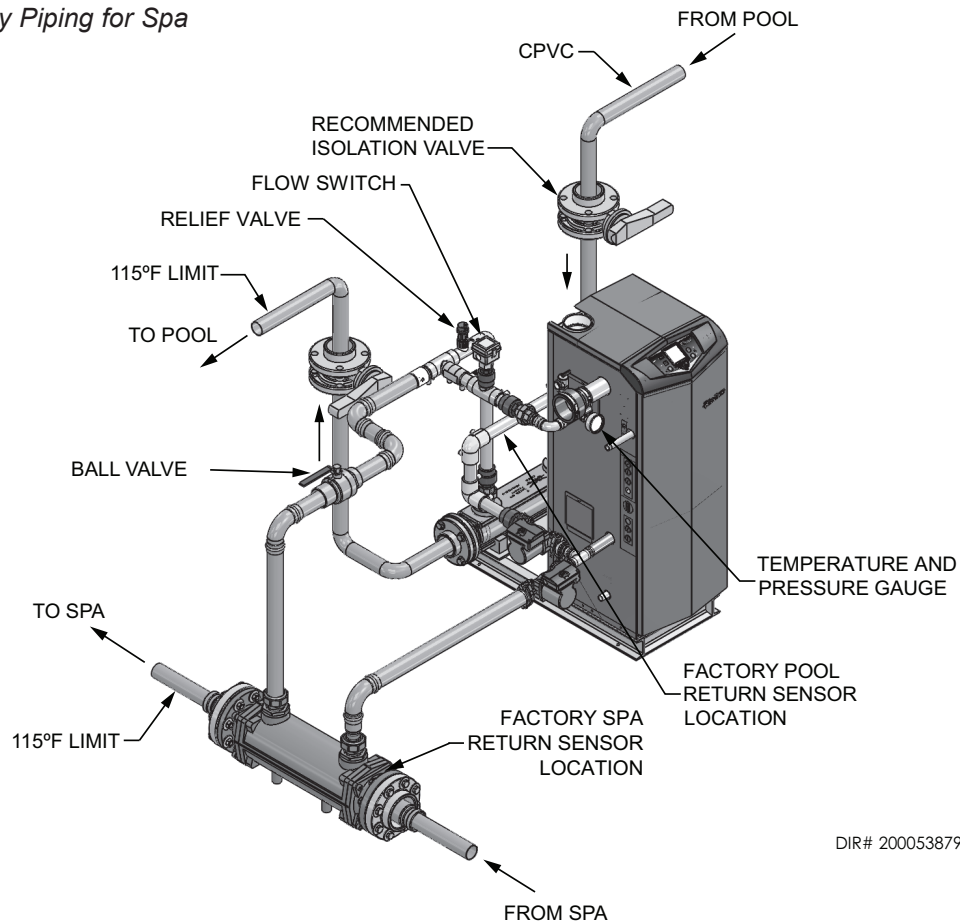

DIR# 2000538790 00

NOTICE

Please note that these illustrations are meant to show system piping concept only, the installer is responsible for all equipment and detailing required by local codes.

NOTICE

Reduce water piping only at Auxiliary HEX tapping. Piping to and from the HEX should be sized so that it is identical to AQUAS piping.

Figure 6-6 Shell and Tube Flow - 100061682

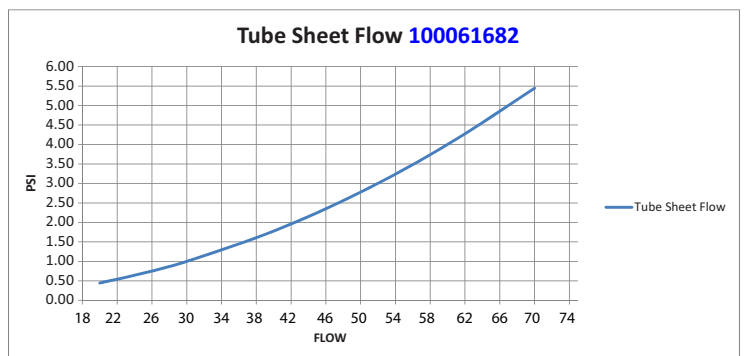
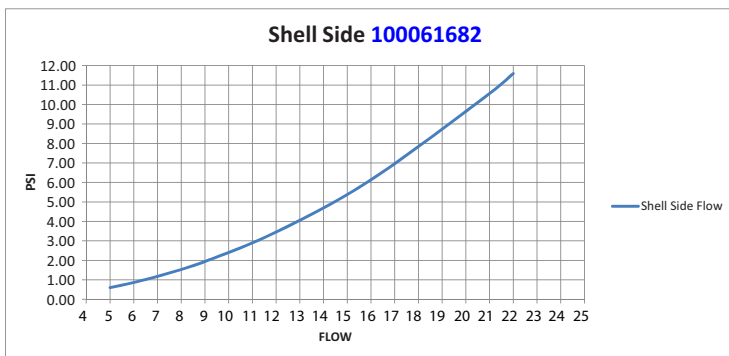

6 Hydronic piping

Low water cutoff device

On a boiler installed above radiation level, some states and local codes require a low water cutoff device at the time of installation.

Freeze protection

Freeze protection for new or existing systems must use glycol that is specially formulated for this purpose. This includes inhibitors, which prevent the glycol from attacking the metallic system components. Make certain to check that the system fluid is correct for the glycol concentration and inhibitor level. The system should be tested at least once a year and as recommended by the producer of the glycol solution. Allowance should be made for the expansion of the glycol solution in the system piping.

WARNING Use only inhibited propylene glycol solutions, which are specifically formulated for hydronic systems. Ethylene glycol is toxic and can attack gaskets and seals used in hydronic systems.

General piping information

IMPORTANT All boiler piping must contain an oxygen barrier. This will help prevent any excess oxygen from entering the system.

Basic steps are listed in this section along with illustrations on the following pages, which will guide you through the installation of the AQUAS Fire Tube boiler.

1. Connect the system return marked "Inlet".
2. Connect the system supply marked "Outlet".
3. Install purge and balance valve or shutoff valve and drain on system return to purge air out of each zone.
4. Install a backflow preventer on the cold feed make-up water line.
5. Install a pressure reducing valve on the cold feed make-up water line, (15 psi nominal). Check temperature and pressure gauge (shipped separately), which should read a minimum pressure of 12 psi.
6. Install a circulator as shown on the piping diagrams in this section. Make sure the circulator is properly sized for the system and friction loss.

7. Install an expansion tank on the system supply. Consult the tank manufacturer's instruction for specific information relating to tank installation. Size the expansion tank for the required system volume and capacity.
8. Install an air elimination device on the system supply.
9. Install a drain valve at the lowest point of the system. **Note:** The boiler cannot be drained completely of water without purging the unit with an air pressure of 15 psi.
10. This appliance is supplied with a relief valve sized in accordance with ASME Boiler and Pressure Vessel Code, Section IV ("Heating Boilers"). The relief valve is installed at the factory on the left side of the boiler. Pipe the discharge of the safety relief valve to prevent injury in the event of pressure relief. Pipe the discharge to a drain. Provide piping that is the same size as the safety relief valve outlet. Never block the outlet of the safety relief valve.
11. It is recommended to install an inlet water strainer to prevent debris from entering the heat exchanger or system.

NOTICE *Please note that these illustrations are meant to show system piping concept only, the installer is responsible for all equipment and detailing required by local codes.

CAUTION The AQUAS Fire Tube boiler is capable of servicing multiple temperature loop systems. It is the responsibility of the installer to protect the loops with lower temperature requirements from higher temperatures that may be required by other loops.

Circulator sizing

The AQUAS Fire Tube boiler heat exchanger does have a pressure drop, which must be considered in your system design.

Table 6E Maximum and Minimum Flow Rates through the Boiler

Model	Minimum Pipe Diameter	Maximum Flow	Minimum Flow (High Fire)	Minimum Flow (Low Fire)
285	1 1/4"	27 gpm	10.8 gpm	1.5 gpm

NOTICE Maximum flow rates are based on boiler inlet and outlet water piping. It is the responsibility of the installer to maintain flow rates based on system piping requirements.

7 Gas connections *(continued)*

Connecting gas supply piping

1. Refer to FIG. 7-1 to pipe gas to the boiler.
 - a. Install ground joint union for servicing, when required.
 - b. Install a manual shutoff valve in the gas supply piping outside boiler jacket when required by local codes or utility requirements.
 - c. In Canada – When using manual main shutoff valves, it must be identified by the installer.
2. Install sediment trap / drip leg.

Figure 7-1 Gas Supply Piping

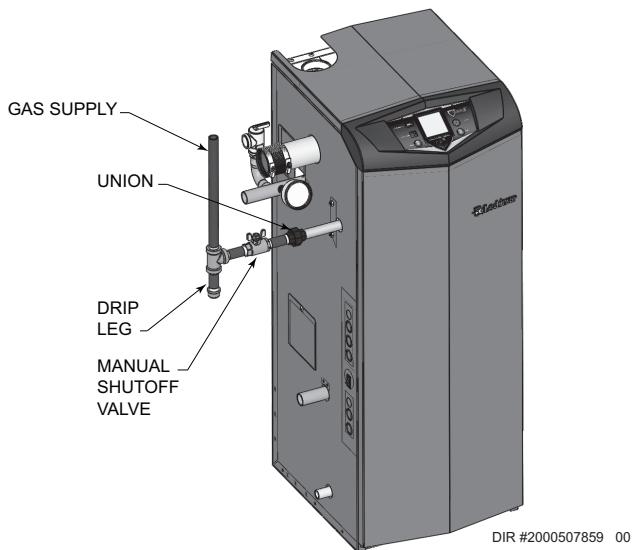

3. Support piping with hangers, not by the boiler or its accessories.

WARNING

The gas valve and blower will not support the weight of the piping. Do not attempt to support the weight of the piping with the boiler or its accessories. Failure to comply could result in severe personal injury, death, or substantial property damage.

4. Purge all air from the gas supply piping.
5. Before placing the boiler in operation, check the boiler and its gas connection for leaks.
 - a. The appliance must be disconnected from the gas supply piping system during any pressure testing of that system at a test pressure in excess of 1/2 PSIG (3.5 kPa).
 - b. The appliance must be isolated from the gas supply piping system by closing a manual shutoff valve during any pressure testing of the gas supply piping system at test pressures equal to or less than 1/2 PSIG (3.5 kPa).
 - c. The appliance and its gas connection must be leak tested before placing it in operation.

WARNING

Do not check for gas leaks with an open flame – use the bubble test. Failure to use the bubble test or check for gas leaks can cause severe personal injury, death, or substantial property damage.

6. Use pipe sealing compound compatible with propane gases. Apply sparingly only to male threads of the pipe joints so that pipe dope does not block gas flow.

WARNING

Failure to apply pipe sealing compound as detailed in this manual can result in severe personal injury, death, or substantial property damage.

WARNING

AQUAS Fire Tube boilers are typically shipped ready to fire on natural gas. Check boiler rating plate to determine which fuel the boiler is set for. If set to natural gas, it may be converted to LP by installing an LP venturi. In order to operate on LP gas, an LP venturi **MUST BE** installed. Failure to comply could result in severe personal injury, death, or substantial property damage.

7 Gas connections

WARNING Use two wrenches when tightening gas piping at boiler (FIG. 7-2), using one wrench to prevent the boiler gas line connection from turning. Failure to support the boiler gas connection pipe to prevent it from turning could damage gas line components.

Figure 7-2 Inlet Pipe with Backup Wrench

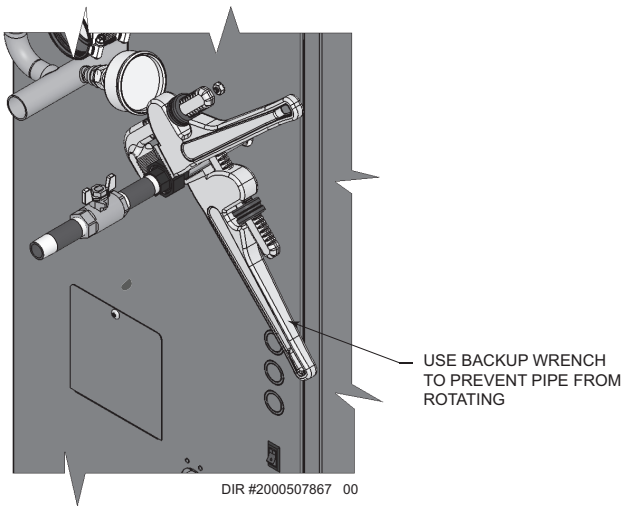

NOTICE Maximum inlet gas pressure must not exceed the value specified. Minimum value listed is for the purposes of input adjustment.

Natural gas:

Pipe sizing for natural gas

1. Refer to Table 7A for pipe length and diameter. Based on rated boiler input (divide by 1,000 to obtain cubic feet per hour).
 - a. Table 7A is only for natural gas with specific gravity 0.60 inches, with a pressure drop through the gas piping of 0.3 inches w.c.
 - b. For additional gas pipe sizing information, refer to ANSI Z223.1 (or B149.1 for Canadian installations).

Natural gas supply pressure requirements

1. Pressure required at the gas valve inlet pressure port:
 - Maximum 14 inches w.c. with no flow (lockup) or with boiler on.
 - Minimum 4 inches w.c. with gas flowing (verify during boiler startup).
2. Install 100% lockup gas pressure regulator in supply line if inlet pressure can exceed 14 inches w.c. at any time. Adjust lockup regulator for 14 inches w.c. maximum.

Propane Gas:

WARNING AQUAS Fire Tube boilers are typically shipped ready to fire on natural gas. Check boiler rating plate to determine which fuel the boiler is set for. If set to natural gas, it may be converted to LP by installing an LP venturi (see page 13). In order to operate on LP gas, an LP venturi **MUST BE** installed. Failure to comply could result in severe personal injury, death, or substantial property damage.

Pipe sizing for propane gas

1. Contact gas supplier to size pipes, tanks, and 100% lockup gas pressure regulator.

Propane Supply Pressure Requirements

1. Adjust propane supply regulator provided by the gas supplier for 14 inches w.c. maximum pressure.
2. Pressure required at gas valve inlet pressure port:
 - Maximum 14 inches w.c. with no flow (lockup) or with boiler on.
 - Minimum 8 inches w.c. with gas flowing (verify during boiler startup).

WARNING Ensure that the high gas pressure regulator is at least 6 - 10 feet upstream of the appliance.

7 Gas connections *(continued)*

Table 7A Natural Gas Pipe Size Chart

Capacity of Schedule 40 Metallic Pipe in Cubic Feet of Natural Gas Per Hour (based on .60 specific gravity, 0.30" w.c. pressure drop)														
Pipe Size (Inches)	Length of Pipe in Straight Feet													
	10	20	30	40	50	60	70	80	90	100	125	150	175	200
1/2	131	90	72	62	55	N/A	N/A	N/A	N/A	N/A	N/A	N/A	N/A	N/A
3/4	273	188	151	129	114	104	95	89	83	79	70	63	58	N/A
1	514	353	284	243	215	195	179	167	157	148	131	119	109	102
1 1/4	1,060	726	583	499	442	400	368	343	322	304	269	244	224	209
1 1/2	1,580	1,090	873	747	662	600	552	514	482	455	403	366	336	313
2	3,050	2,090	1,680	1,440	1,280	1,160	1,060	989	928	877	777	704	648	602
2 1/2	4,860	3,340	2,680	2,290	2,030	1,840	1,690	1,580	1,480	1,400	1,240	1,120	1,030	960
3	8,580	5,900	4,740	4,050	3,590	3,260	3,000	2,790	2,610	2,470	2,190	1,980	1,820	1,700
4	17,500	12,000	9,660	8,270	7,330	6,640	6,110	5,680	5,330	5,040	4,460	4,050	3,720	3,460

WARNING AQUAS Fire Tube boilers are typically shipped ready to fire on natural gas. Check boiler rating plate to determine which fuel the boiler is set for. If set to natural gas, it may be converted to LP by installing an LP venturi (see page 13). In order to operate on LP gas, an LP venturi **MUST BE** installed. Failure to comply could result in severe personal injury, death, or substantial property damage.

Check inlet gas supply

NOTICE CSA or UL listed flexible gas connections are acceptable, but you must exercise caution to ensure that the line has adequate capacity to allow your boiler to fire at full rate. Consult with local codes for proper installation or service procedures.

WARNING DO NOT adjust gas valve outlet pressure. The gas valve is factory-set for the correct outlet pressure. This setting is suitable for natural gas and propane, requiring no field adjustment. Attempting to alter the gas valve outlet pressure could result in damage to the valve, causing potential severe personal injury, death, or substantial property damage.

The gas piping must be sized for the proper flow and length of pipe, to avoid excessive pressure drop. Both the gas meter and the gas regulator must be properly sized for the total gas load.

If you experience a pressure drop greater than 1 inch w.c., the meter, regulator, or gas line is undersized or in need of service. Perform the steps below when checking inlet gas supply:

1. Turn the main power switch to the "OFF" position.
2. Shut off gas supply at the manual gas valve in the gas piping to the appliance.
3. Loosen the set screw one (1) full turn from inside the pressure tap on top of the gas valve. Place the tubing of the manometer over the tap once the set screw is loosened as shown in FIG. 7-3.
4. Slowly turn on the gas supply at the field installed manual gas valve.
5. Turn the power switch to the "ON" position.
6. Locate the pinhole button above the RESET button on the display board (FIG. 11-1 on page 68). Insert a thin wire (such as a paper clip) into the hole and press the button once and hold for 5 seconds to place the boiler into Service Mode. In Service Mode the boiler will fire at ignition speed and will then modulate up to full fire.
7. Observe the gas supply pressure as the burner fires at 100% of rated input. Percent of burner input will be displayed on the control panel.
8. Ensure inlet pressure is within specified range. Minimum and maximum gas supply pressures are specified in this section of the manual.
9. If gas supply pressure is within normal range and no adjustments are needed, proceed on to Step 11.
10. If the gas pressure is out of range, contact the gas utility, gas supplier, qualified installer, or service agency to determine the necessary steps to provide proper gas pressure to the control.
11. Place the boiler back into normal operation by pressing STOP.

7 Gas connections

⚠ WARNING

When re-tightening the set screw, be sure to tighten securely to prevent gas leaks.

Do not check for gas leaks with an open flame -- use the bubble test. Failure to use the bubble test or check for gas leaks can cause severe personal injury, death, or substantial property damage.

12. Turn the power switch to the "OFF" position.
13. Shut off the gas supply at the manual gas valve in the gas piping to the appliance.
14. Remove the manometer from the pressure tap on top of the gas valve. Re-tighten the set screw inside the pressure tap.
15. Turn on the gas supply at the manual gas valve.
16. Turn the power switch to the "ON" position.
17. Check burner performance by cycling the system while you observe burner response. The burner should ignite promptly. Flame pattern should be stable. Turn system off and allow burner to cool, then cycle burner again to ensure proper ignition and flame characteristics.

Gas Pressure

The gas pressure must remain between 4 inches w.c. (natural), 8 inches w.c. (LP) minimum and 14 inches w.c. (natural and LP) maximum during stand-by (static) mode and while in operating (dynamic) mode. If an in-line regulator is used, it must be a minimum of 10 feet from the AQUAS Fire Tube boiler. It is very important that the gas line is properly purged by the gas supplier or utility company. Failure to properly purge the lines or improper line sizing, will result in ignition failure.

The problem is especially noticeable in NEW LP installations and also in empty tank situations. This can also occur when a utility company shuts off service to an area to provide maintenance to their lines.

Gas valve replacement

The gas valve **MUST NOT** be replaced with a conventional gas valve under any circumstances. As an additional safety feature, this gas valve has a flanged connection to the venturi and blower.

⚠ WARNING

Failure to follow all precautions could result in fire, explosion, or death!

Figure 7-3 Inlet Gas Supply Check

LOOSEN THE SET SCREW ONE (1) FULL TURN
AND PLACE THE MANOMETER TUBING OVER
THE PRESSURE TAP

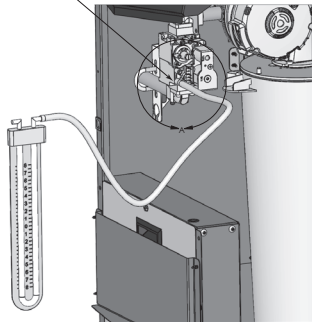

DIR #2000507872 00

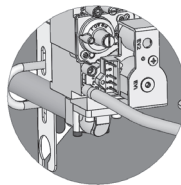

DETAIL A

8 Field wiring

WARNING ELECTRICAL SHOCK HAZARD – For your safety, turn off electrical power supply before making any electrical connections to avoid possible electric shock hazard. Failure to do so can cause severe personal injury or death.

NOTICE Wiring must be N.E.C. Class 1.
If original wiring as supplied with boiler must be replaced, use only type 105°C wire or equivalent.

Boiler must be electrically grounded as required by National Electrical Code ANSI/NFPA 70 – latest edition.

NOTICE This boiler is equipped with a feature that saves energy by reducing the boiler water temperature as the heating load decreases. This feature is equipped with an override, which is provided primarily to permit the use of an external energy management system that serves the same function. This override **MUST NOT** be used unless at least one of the following conditions is true:

1. An external energy management system is installed that reduces the boiler water temperature as the heating load decreases.
2. This boiler is not used for any space heating.
3. This boiler is part of a modular or multiple boiler system having a total input of 300,000 Btuh/hr or greater.
4. This boiler is equipped with a tankless coil.

CAUTION Label all wires prior to disconnection when servicing controls. Wiring errors can cause improper and dangerous operation.

Installation must comply with:

1. National Electrical Code and any other national, state, provincial, or local codes or regulations.
2. In Canada, CSA C22.1 Canadian Electrical Code Part 1, and any local codes.

Line voltage connections

1. Connect 120 VAC power wiring to the line voltage terminal strip in the junction box, as shown in FIG. 8-1.
2. Provide and install a fused disconnect or service switch (15 amp recommended) as required by the code (see FIG. 8-1).
3. The boiler pump is shipped loose. Wire the boiler pump as shown in FIG. 8-1.
4. When connecting a domestic hot water (DHW) pump, connect the wiring to the line voltage terminal strip as shown in FIG. 8-1.
5. To activate a system pump, wire as shown in FIG. 8-1. If the motor is larger than 1/8 hp or 1.8 amps, you must isolate with a relay.

Low voltage connections

1. Route all low voltage wires through the knockouts on the left side, as shown in FIG. 8-2.
2. Connect low voltage wiring to low voltage connection board as shown in FIG. 8-3 on page 51 of this manual and the boiler wiring diagram.

Figure 8-1 Line Voltage Field Wiring Connections

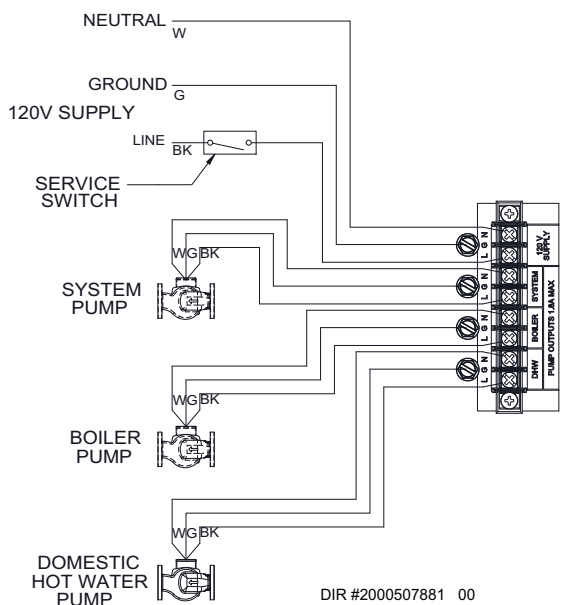

DIR #2000507881 00

Figure 8-2 Routing Field Wiring

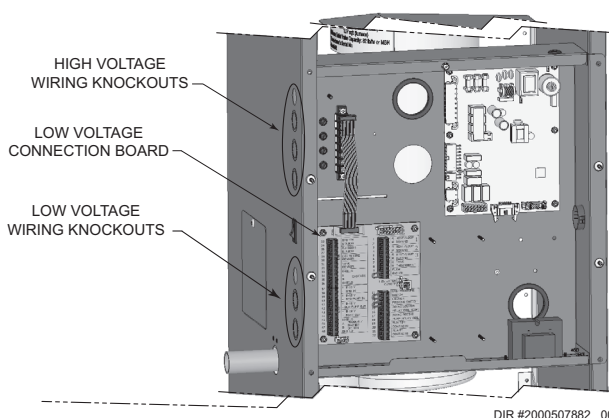

DIR #2000507882 00

8 Field wiring

Thermostat

1. Connect the room thermostats or end switches (isolated contact only) to Heat/Loop Demand 1, 2, or 3, as shown in FIG. 8-3.
2. Install the thermostat on the inside wall away from influences of drafts, hot or cold water pipes, lighting fixtures, television, sunlight, or fireplaces.
3. Thermostat anticipator (if applicable):
 - a. If connected directly to boiler, set for 0.1 amps.
 - b. If connected to relays or other devices, set to match total electrical power requirements of connected devices. See device manufacturers' specifications and thermostat instructions for details.

Outdoor temperature sensor

In the absence of an external energy management system, an outdoor temperature sensor must be used.

1. Mount the sensor on an exterior wall, shielded from direct sunlight or flow of heat or cooling from other sources.
2. Route sensor wires through a knockout at the rear of the boiler (see FIG. 8-2).
3. Connect outdoor temperature sensor (FIG. 8-3) to the outdoor sensor terminals on the connection board to enable outdoor reset operation of the AQUAS Fire Tube boiler.

DHW thermostat

Connect storage indirect water heater (DHW) thermostat (FIG. 8-3) to the DHW thermostat terminals on the connection board. If a tank sensor is connected (see DHW Tank Sensor below) the tank thermostat is ignored.

DHW tank sensor

1. By installing a tank sensor, the SMART SYSTEM control can perform the tank thermostat function. The SMART SYSTEM control automatically detects the presence of this sensor and generates a DHW call for heat when the tank temperature drops 6°F (3°C) below the tank set point and finishes the call for heat when the tank temperature reaches the tank set point.
2. The tank sensor included with the Lochinvar Squire Indirect DHW tank (#100170544) is the only sensor suitable for use with the SMART SYSTEM control. Connect the sensor leads to the Tank Sensor terminals on the Low Voltage Connection Board (FIG. 8-3).



WARNING

Failure to use the correct sensor may result in the tank temperature being either above or below the set point.

3. If the #100170544 is not compatible with the indirect tank, a tank thermostat can be used to control the boiler. The tank thermostat should be installed per the manufacturers instructions and wired to the DHW Thermostat terminals on the Low Voltage Connection Board.

Louver relay

If louvers need to operate when the boiler fires, they can be controlled by this output. Connect these terminals to a 24 VAC relay coil, which is wired to operate the louvers (FIG. 8-3).

Louver proving switch

When the operation of the louvers needs to be verified before the boiler fires, remove the jumper wire from these terminals and connect them to the normally open contacts on its proving switch (FIG. 8-3).

High gas pressure switch

If a switch is provided to detect excessive gas pressure, remove the jumper wire from the terminals on the connection board, and then connect them to its normally closed contacts (FIG. 8-3).

Low gas pressure switch

1. If a switch is provided to detect low gas pressure, remove the jumper wire from the terminals on the connection board and connect them to its normally open contacts (FIG. 8-3).
2. If both a high and low gas pressure switch is used, connect their respective contacts in series, and connect them to the terminals on the connection board (FIG. 8-3).

Variable speed system pump

If a variable speed pump is used in the primary loop, and a 0-10V signal is available from the pump speed control, this signal can be used by the SMART SYSTEM control to anticipate changes in the building heat load. By connecting this 0 - 10V signal to the 0 - 10V SYS PUMP IN terminals, the boiler (or cascade) can modulate up and down as the primary flow increases and decreases.

Boiler pump speed output

This 0 - 10V output is available to control the speed of a variable speed boiler pump. The SMART SYSTEM control will vary the speed of this pump in order to maintain a minimum ΔT across the heat exchanger, as well as prevent high limit lockouts when the flow in the primary loop is extremely low. **Note:** This feature is to be used with Primary Secondary Piping systems only. A system supply sensor must be installed. Connect this output to the 0 - 10V input on the boiler pump speed control.

Rate output

This output provides a 0 - 10V signal that is proportional to the firing rate of the boiler. This may be used by a BMS system to monitor the actual rate of the boiler.

ModBus/BACnet

When the optional ModBus or BACnet interface module is installed, the RS-485 cable is connected to these terminals. Use shielded, 2-wire twisted pair cable. If desired, the shield can be connected to ground by installing a jumper wire between terminals 1 and 3 on connector X5 on the optional ModBus/BACnet interface module.

8 Field wiring *(continued)*

Flow switch

1. A flow switch is used to guarantee flow through the boiler before allowing it to fire. The flow switch must be installed at the boiler outlet.
2. Remove the jumper wire from these terminals, and connect these terminals to the normally open contacts on the flow switch (FIG. 8-3).

System supply sensor

1. By installing the system supply sensor into the supply of the primary loop, the temperature of the primary supply can be controlled. The SMART SYSTEM control automatically detects the presence of this sensor, and controls the boiler firing rate to maintain the system supply temperature to the set point (if the outlet sensor control is currently selected). If it is desired to control the system return temperature, then program the SMART SYSTEM control to use the inlet sensor as the controlling sensor. See the AQUAS Fire Tube boiler Service Manual for instructions on how to use the inlet sensor as the controlling sensor. When the inlet sensor is programmed as the controlling sensor, it is vital that the SYSTEM SUPPLY sensor be installed. **DO NOT INSTALL THE SYSTEM SUPPLY SENSOR INTO THE SYSTEM RETURN.**
2. The #100170581 sensor provided with the boiler must be used for the system sensor.
3. Connect these terminals to the system supply sensor (FIG. 8-3).

Boiler management system

The United States Energy Policy and Conservation Act requires residential heating boilers with inputs less than 300,000 Btu/hr be equipped with a control that automatically adjusts boiler water temperature in relation to heat demand. An external control may be connected to control the firing rate or the set point of the boiler provided that either an external energy management system is installed that reduces the boiler water temperature as the heating load decreases, the boiler is not used for any space heating, or the boiler is part of a modular or multiple boiler system having a total input of 300,000 Btu/hr or greater.

1. An external control may be connected to control either the firing rate or the set point of the boiler. If the external control uses a set of contacts to enable the boiler, connect the contacts to the Heat/Loop Demand 1 terminals. Otherwise, the SMART SYSTEM control will be enabled by the 0-10V signal.
2. Make sure the (-) terminal is connected to the (-) or common output terminal of the external control, and the 0 - 10 Vdc terminal is connected to the 0 - 10 Vdc terminal of the external control. Make sure the (-) voltage is not below ground.

Runtime contacts

The SMART SYSTEM control closes a set of dry contacts whenever the burner is running. This is typically used by Building Management Systems to verify that the boiler is responding to a call for heat.

Alarm contacts

The SMART SYSTEM control closes another set of contacts whenever the boiler is locked out or the power is turned off. This can be used to turn on an alarm, or signal a Building Management System that the boiler is down.

DHW recirculation sensor

The AQUAS Fire Tube boiler is able to control a DHW recirculation pump. To operate this feature, a #100170581 temperature sensor must be installed in the circulation loop return. Connect this sensor to the DHW recirculation sensor terminals on the Low Voltage Connection Board.

DHW recirculation pump

When the DHW recirculation sensor (as described above) is connected, the AQUAS Fire Tube SMART SYSTEM control will output 24 VAC to control a DHW recirculation pump relay (field supplied). Connect the coil of the DHW recirculation pump relay to the 24 VAC recirculation pump relay coil terminals on the Low Voltage Connection Board.

Wiring of the cascade

When wiring the boilers for Cascade operation, select one boiler as the Leader boiler. The remaining boilers will be designated as Members. See page 65 "Configuration of the Cascade" for a detailed explanation of this procedure.

Connect the system supply sensor and outdoor air sensor (if used) to the Leader boiler. For the Cascade system to work properly the system supply sensor must be installed. The location of the system supply sensor should be downstream of the boiler connections in the main system loop. The system supply sensor should be wired to the Low Voltage Connection Board at the terminals marked for the system sensor (see FIG. 8-3). The Leader control will use the water temperature at the system supply sensor to control the operation of the Cascade.

8 Field wiring

If outdoor air reset is desired, the outdoor air sensor should be wired to the Low Voltage Connection Board at the terminals marked for the outdoor air sensor (FIG. 8-3). If the outdoor air sensor is connected, the Leader control will calculate the water temperature set point based on the programmed reset curve parameters. If the outdoor air sensor is not connected, the Leader control will maintain the fixed water temperature set point that is programmed into the control.

If a Thermostat, Zone Control enable output, or Building Management System enable output is available, it should be wired to the Low Voltage Connection Board on the Leader boiler at the terminals marked for one of the heat/loop demands 1-3 (FIG. 8-3). If the boilers are to run continuously, connect a jumper wire between the R and W terminals for the heat/loop demand input. This will initiate a call for heat on the Cascade.

Communication between the Leader boiler and the Member boilers is accomplished by using shielded, 2-wire twisted pair communication cable. Connect one of the twisted pair wires to Cascade terminal A on each of the Low Voltage Connection boards, and the other wire of the twisted pair to Cascade terminal B on each of the Low Voltage Connection Boards. Connect the shield wires to one of the shield terminals on the Low Voltage Connection Boards (FIG. 8-3). If more than two boilers are on the Cascade, daisy chain the wiring from the Cascade terminals on the second boiler to the Cascade terminals on the third boiler, then from the third to the fourth, and so on. The connections between boilers can be made in any order, regardless of the addresses of the boilers. Try to keep each cable as short as possible.

When the Member 1 boiler is programmed as an alternate leader this allows the Member 1 boiler to automatically assume control of the Cascade should it lose communications with the Leader boiler. When programmed to YES, it is recommended that the Member 1 boiler have its own set of external sensors installed (such as the system supply sensor), to maintain the same level of temperature control as with the Leader boiler. Voltage signals (such as 0 - 10V system pump speed input) can be connected to both boilers.

**WARNING**

DO NOT connect the sensors connected to the Leader boiler to the Member 1 boiler. The actual water temperatures will be higher than expected, which could lead to property damage, personal injury, or death.

When communication is re-established with the Leader boiler, Member 1 will automatically relinquish control of the Cascade to the Leader boiler.

8 Field wiring (continued)

Figure 8-3 Low Voltage Field Wiring Connections

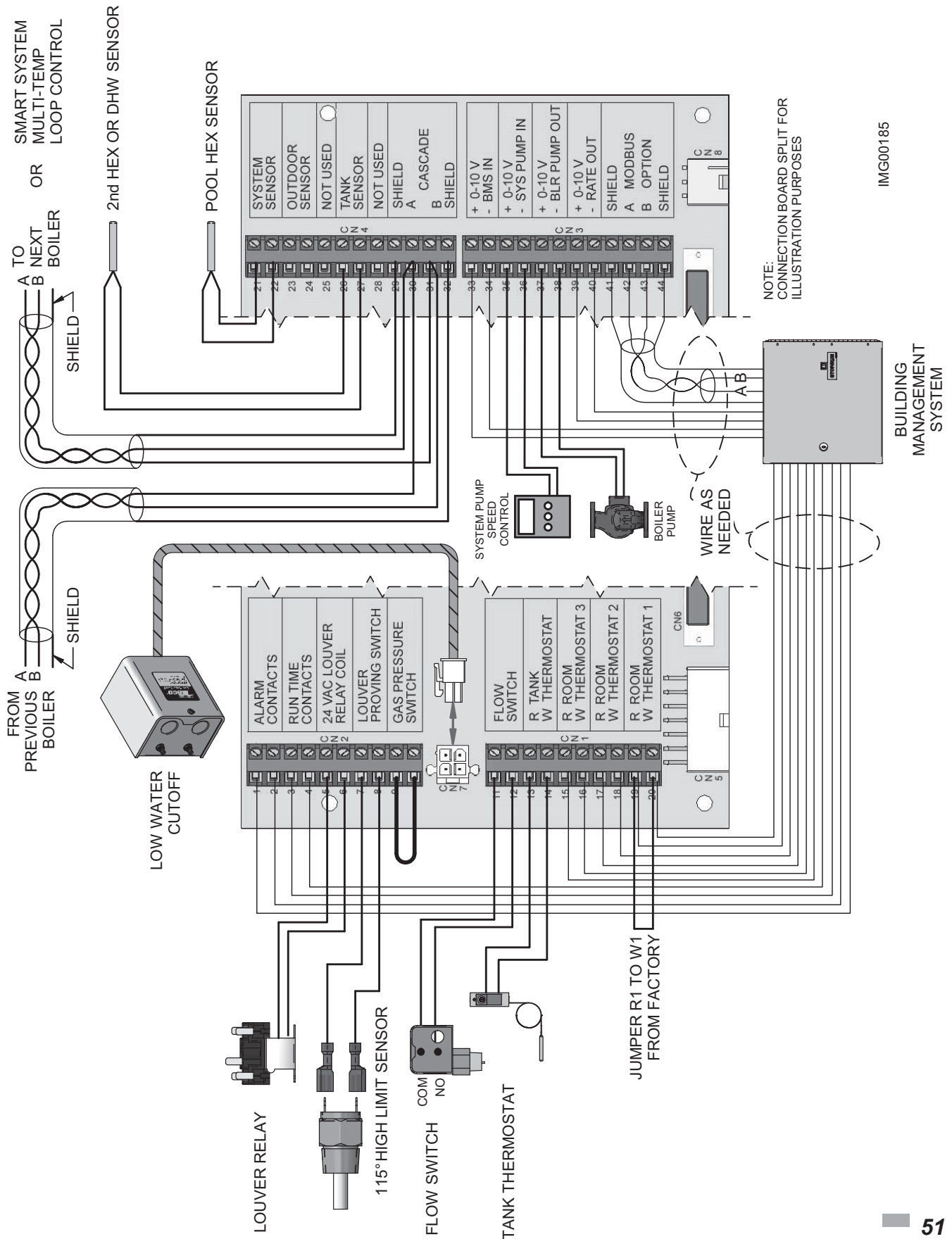

9 Condensate disposal

Condensate drain

1. The AQUAS Fire Tube boiler is a high efficiency appliance that produces condensate.
2. The condensate trap has a 1/2" outlet connection pipe for tubing.
3. Slope condensate tubing down and away from the boiler into a drain or condensate neutralizing filter. Condensate from the AQUAS Fire Tube boiler will be slightly acidic (typically with a pH from 3 to 5). Install a neutralizing filter if required by local codes.

A Neutralizer Kit (#100157721) is available from the factory (FIG. 9-1).

4. Do not expose condensate line to freezing temperatures.

NOTICE

Use materials approved by the authority having jurisdiction. In the absence of other authority, PVC and CPVC pipe must comply with ASTM D1785 or D2845. Cement and primer must comply with ASME D2564 or F493. For Canada use CSA or ULC certified PVC or CPVC pipe, fittings, and cement.

NOTICE

To allow for proper drainage on large horizontal runs, a second line vent may be required and tubing size may need to increase to 1 inch.

The condensate line must remain unobstructed, allowing free flow of condensate. If condensate is allowed to freeze in the line or if the line is obstructed in any other manner, condensate can exit from the boiler tee, resulting in potential water damage to property.

5. A condensate removal pump is required if the boiler is below the drain. When installing a condensate pump, select one approved for use with condensing boilers and furnaces. The pump should have an overflow switch to prevent property damage from condensate spillage. The switch should be wired in series with the blocked drain switch inside the boiler (see FIG. 10-3 on page 55).

Figure 9-1 Condensate Disposal

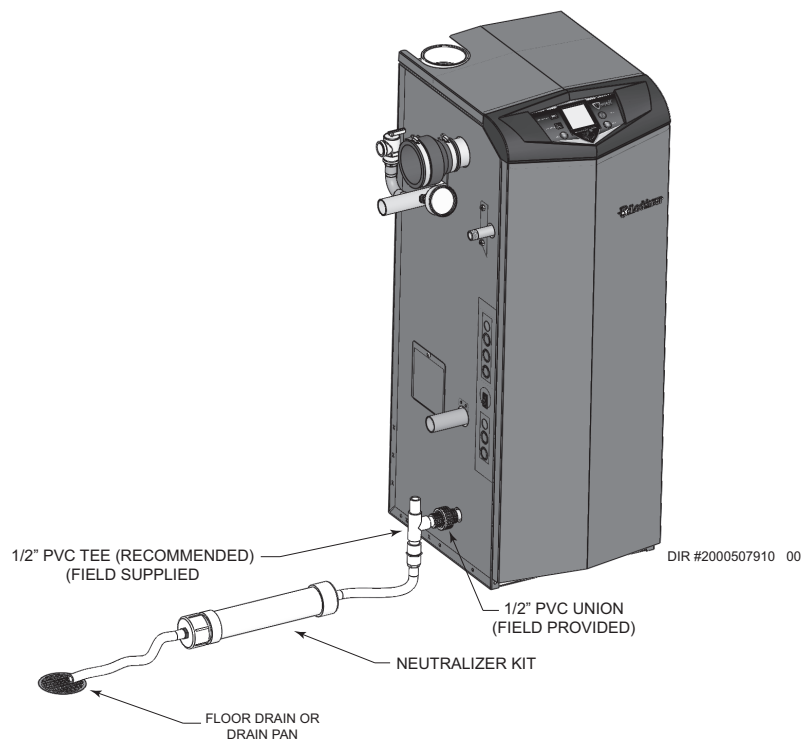

10 Start-up

Fill water

Check/control fill water chemistry

IMPORTANT

Conduct water quality testing prior to installing the appliance. Various solutions are available to adjust water quality.

Pool Water Chemistry

It is essential that the instructions in this section along with the Ryznar Stability Index and/or Calcium Stability Index are followed to prevent corrosion / erosion of the indirect heat exchanger:

- Always keep pH to within correct levels. The ideal pool pH should be kept to within 7.4 to 7.6.
- Under no circumstances should the pH fall below 7.2 or rise above 7.8 (see FIG. 10-1). Check on a day-to-day basis. Alter pool condition as necessary.
- Ensure that chlorine levels are within the range recommended by the chemical manufacturer and are in accordance with the type of pool, for example; private, hotel, school, or municipal.
- If a bypass is fitted to the indirect heat exchanger circuit, it is essential that any or all of the valves are correctly positioned to allow the recommended pool water flow to pass through the heat exchanger.
- The system filter unit should be checked regularly, especially sand filters (to detect sand and diatomaceous earth). Sand filters, if working incorrectly, can allow sand to pass around the pool circuit causing erosion of the pipework and heat exchanger. Keep the pool free from debris such as leaves, grass cuttings, etc. This foreign matter can cause decay and increase pH.
- It is essential that the correct amount of chlorine dosage is added to the pool. To allow proper dispersion of the dose in the pool water, distribute the chemicals to various areas of the pool. Do not dose in one area only, as this will create high acidic areas which can cause corrosion / erosion of the pool equipment.

Figure 10-1 pH Scale

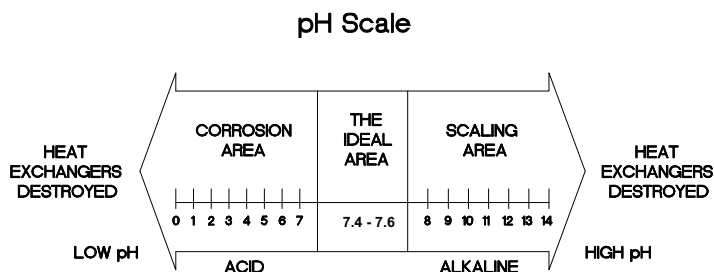

- Chlorinators must feed downstream of the boiler and have an anti-siphoning device to prevent chemical backup in the heater when the pump is shut off.

CAUTION

High chemical concentrations from improperly adjusted feeders, chlorinators or salt levels above 5000 ppm can cause rapid corrosion to the heat exchanger.

Filling the System

The boiler is filled through the pressure reducing auto-fill valve. The operating pressure of this system is 15 psi between the heater and the indirect heat exchanger. There are no adjustments necessary to the fill valve cartridge (factory set). The expansion tank is set at 20 psi. It is necessary to check the pressure of the expansion tank when annual maintenance is performed. The boiler system operates off a city or potable water system which feeds a closed loop system. A hard line is piped from the potable water supply to the pressure reducing valve. This water is to remain on at all times when the system is in operation.

Pressure Reducing Valve

The valve is equipped with a fast-fill feature that can be used to override normal operation when filling and purging the system. To activate fast-fill, push and hold down the fast-fill knob on top of the cartridge as shown in FIG. 10-2.

Relieve air from the system through operation of the pressure relief valve by pulling the lever on top of the valve, causing it to open.

Figure 10-2 Pressure Reducing Auto-Fill Valve

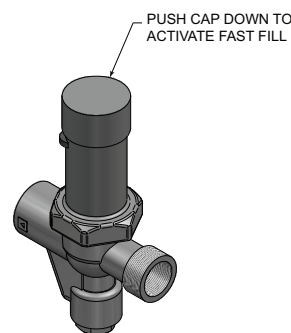

Freeze protection



WARNING

Ethylene glycol is toxic, DO NOT use as your freeze protection. Ethylene glycol has a sweet aroma which children and pets could mistake as food and ingest; leading to death.

1. Use glycol only if needed for freeze protection.
2. Propylene glycol is the recommended freeze protection.
3. Make sure to flush the boiler system before adding glycol.

10 Start-up

4. Determine the freeze protection fluid quantity using system water content, following the fluid manufacturer's instructions. Boiler water content is listed on page 7. Remember to include expansion tank water content.
5. Local codes may require a backflow preventer or actual disconnect from city water supply.
6. When using freeze protection fluid with automatic fill, it is suggested to install a water meter to monitor water makeup. Freeze protection fluid may leak before the water begins to leak, causing the concentration to drop, which reduces the freeze protection level.
7. The freeze protection set points may be lowered when freeze protection fluid is used (see the Knight Fire Tube Service Manual).
8. Consult the glycol manufacturer for details on the suggested mix of glycol and water for the desired freeze protection level and the de-rate effect it will have on the boiler output.

Test / replace freeze protection fluid

1. For systems using freeze protection fluids, follow the fluid manufacturer's instructions.
2. Freeze protection fluid must be replaced periodically due to degradation of inhibitors over time.
3. It is recommended to test the glycol concentration annually and adjust within the desired set points.

Oxygen prevention

CAUTION

Eliminate all system leaks. Continual fresh makeup water will reduce boiler life. Minerals can build up in the heat exchanger, reducing heat transfer, overheating the heat exchanger, and causing heat exchanger failure.

Dissolved oxygen can have a negative effect on the boiler system. Oxygen can cause iron oxide to generate iron deposits. Oxygen may also increase the rate of corrosion on non-stainless steel parts of the system. A low pH level combined with oxygen further enhances its corrosive effects. After boiler installation, check for air leaks in the following areas:

- Suction gasket
- Pump
- Air valve
- O-ring gaskets

Precautions include installing a water meter to evaluate the fresh water volume entering the system. Additional volumes of fresh water could indicate that a leak is present.

Boiler water

CAUTION

Do not use petroleum based cleaning or sealing compounds in the boiler system. Gaskets and seals in the system may be damaged. This can result in substantial property damage.

DO NOT use "homemade cures" or "boiler patent medicines". Serious damage to boiler, personnel, and/or property may result.

- Monitoring pH, TDS and hardness levels can prolong the life of the appliance by reducing lime scale buildup, corrosion, and erosion. Check for leaks to ensure that fresh water is not entering the system.
- Continual fresh make-up water will reduce boiler life.
- Mineral buildup in the heat exchanger reduces heat transfer, overheats the stainless steel heat exchanger, and causes failure.
- The addition of oxygen carried in by make-up water can cause internal corrosion in system components.
- Leaks in the boiler or piping must be repaired at once to prevent make-up water. It could be helpful to install a water meter for this purpose to easily check the amount of make-up water entering the system.

Fill and test water system

1. Fill system only after ensuring the water meets the requirements of this manual.
2. Close automatic and manual air vents and boiler drain valve.
3. Fill to correct system pressure. Correct pressure will vary with each application.
 - a. The minimum cold water fill pressure for a system is 12 psi.
 - b. Pressure will rise when the boiler is turned ON and system water temperature increases.
4. At initial fill and during boiler startup and testing, check the system thoroughly for any leaks. Repair all leaks before proceeding further.

10 Start-up *(continued)*

Purge air from water system

1. Purge air from system:
 - a. Connect a hose to the purge valve. Route the hose to an area where water can drain and be seen.
 - b. Close the boiler or system isolation valve between the purge valve and fill connection to the system.
 - c. Close zone isolation valves.
 - d. Open the quick-fill valve on the cold water makeup line.
 - e. Open purge valve.
 - f. Open the isolation valves one zone at a time. Allow water to run through the zone, pushing out the air. Run until no noticeable air flow is present. Close the zone isolation valves and proceed with the next zone. Follow this procedure until all zones are purged.
 - g. Close the quick-fill water valve and purge valve and remove the hose. Open all isolation valves. Watch that system pressure rises to correct cold-fill pressure.
 - h. After the system has operated for a while, eliminate any residual air by using the manual air vents located throughout the system.
 - i. If purge valves are not installed in the system, open the manual air vents in the system one at a time, beginning with the lowest floor. Close the vent when water squirts out. Repeat with remaining vents.
2. Open the automatic air vent (diaphragm-type or bladder type expansion tank systems only) one turn.
3. Open other vents:
 - a. Starting on the lowest floor, open air vents one at a time until water squirts out.
 - b. Repeat with remaining vents.
4. Refill to correct pressure.

Check for gas leaks



WARNING Before starting the boiler, and during initial operation, smell near the floor and around the boiler for gas odorant or any unusual odor. Remove the top access panel and smell the interior of the boiler enclosure. Do not proceed with startup if there is any indication of a gas leak. Use an approved leak detection solution. Repair any leaks at once.



WARNING DO NOT adjust gas valve outlet pressure. The gas valve is factory set for the correct outlet pressure. This setting is suitable for natural gas and propane, requiring no field adjustment. Attempting to alter the gas valve outlet pressure could result in damage to the valve, causing potential severe personal injury, death, or substantial property damage.

Figure 10-3 Condensate Trap

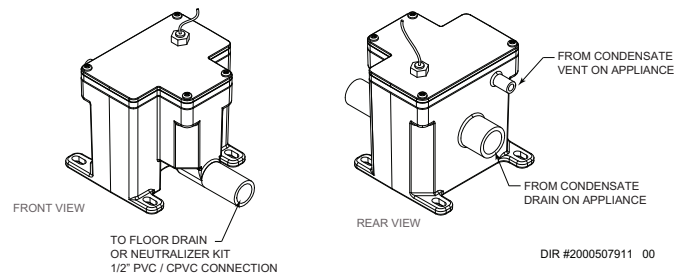

WARNING Propane boilers only – Your propane supplier mixes an odorant with the propane to make its presence detectable. In some instances, the odorant can fade, and the gas may no longer have an odor. Before startup (and periodically thereafter), have the propane supplier verify the correct odorant level in the gas.

Check thermostat circuit(s)

1. Disconnect the two external wires connected to each of the heat/loop demand terminals on the connection board.
2. Connect a voltmeter across these two incoming wires. Close each thermostat, zone valve, and relay in the external circuit one at a time and check the voltmeter reading across the incoming wires.
3. There should NEVER be a voltage reading.
4. If a voltage does occur under any condition, check and correct the external wiring. (This is a common problem when using 3-wire zone valves.)
5. Once the external thermostat circuit wiring is checked and corrected if necessary, reconnect the external thermostat circuit wires to the connection board.

Inspect/fill condensate system

Inspect/check condensate lines and fittings

1. Inspect the condensate drain line, condensate PVC fittings, and condensate trap.

10 Start-up

Final checks before starting the boiler

- ❑ Read the Knight Fire Tube Boiler Service Manual to familiarize yourself with SMART SYSTEM control module operation. Read this manual, page 59 for proper steps to start boiler.
- ❑ Verify the boiler and system are full of water and all system components are correctly set for operation.
- ❑ Verify the preparation procedures of Section 10, pages 53 thru 56 have been completed.
- ❑ Verify electrical connections are correct and securely attached.
- ❑ Inspect vent piping and air piping for signs of deterioration from corrosion, physical damage, or sagging. Verify air piping and vent piping are intact and correctly installed per this manual.

Start the boiler

1. Read and follow the Operating instructions in FIG. 10-4, page 59.

If boiler does not start correctly

1. Check for loose connections, blown fuse, or service switch off?
2. Is boiler water temperature above 200°F?
3. Is thermostat set below room temperature?
4. Is gas turned on at meter or boiler?
5. Is incoming gas pressure less than 4 inches w.c.?

If none of the above corrects the problem, refer to the Troubleshooting Section of the Knight Fire Tube Boiler Service Manual.

Check system and boiler

❑ Check water piping

1. Check system piping for leaks. If found, shut down the boiler and repair immediately. (See WARNINGS on pages 53 thru 56 (startup) regarding failure to repair leaks.)
2. Vent any remaining air from the system using manual vents. Air in the system will interfere with circulation and cause heat distribution problems and noise.

❑ Check vent piping and air piping

1. Check for gastight seal at every connection, seam of air piping, and vent piping.



WARNING

Venting system must be sealed gastight to prevent flue gas spillage and carbon monoxide emissions, which will result in severe personal injury or death.

❑ Check gas piping

1. Check around the boiler for gas odor following the procedure on page 43 of this manual (connecting gas supply piping).



WARNING

If you discover evidence of any gas leak, shut down the boiler at once. Find the leak source with a bubble test and repair immediately. Do not start the boiler again until corrected. Failure to comply could result in severe personal injury, death, or substantial property damage.

❑ Propane boilers – verify conversion

1. Verify propane conversion has been completed per the Propane Conversion instructions.



WARNING

DO NOT adjust gas valve outlet pressure. The gas valve is factory-set for the correct outlet pressure. This setting is suitable for natural gas and propane, requiring no field adjustment. Attempting to alter the gas valve outlet pressure could result in damage to the valve, causing potential severe personal injury, death, or substantial property damage.



WARNING

AQUAS Fire Tube boilers are typically shipped ready to fire on natural gas. Check boiler rating plate to determine which fuel the boiler is set for. If set to natural gas, it may be converted to LP by installing an LP venturi (see page 13). In order to operate on LP gas, an LP venturi MUST BE installed. Failure to comply could result in severe personal injury, death, or substantial property damage.

Check flame and combustion

1. Turn the main power off to the boiler by placing the “On/Off” switch in the OFF position.
2. When using PVC/CPVC remove the 1/2" combustion plug from the tee supplied in the installation kit (see FIG. 3-7 on page 20). For all other venting options, remove the flue temperature sensor from the flue pipe connection. **Note:** Combustion measurements will be made at this point.
3. Turn the main power on to the boiler by placing the “On/Off” switch in the ON position.

10 Start-up *(continued)*

NOTICE

Please note that the brackets ([]) denote screen status.

- Place the boiler into the active position by pressing the RIGHT SELECT [ON] key (FIG. 11-1, page 68).
- Locate the pinhole button above the RESET button on the display board (FIG. 11-1). Insert a thin wire (such as a paper clip) into the hole and press the button once and hold for 5 seconds to place the boiler into Service Mode. In Service Mode the boiler will fire at ignition speed and will then modulate up to full fire.
- Insert the probe from a combustion analyzer into the hole left by the removal of the 1/2" combustion plug (FIG. 3-7, page 20) or the flue temperature sensor.
- Once the boiler has modulated up to full fire, measure the combustion. The values should be in the range listed in Table 10A below. The CO levels should be less than 150 ppm for a properly installed unit.

If the combustion is not within the specified range, reference the Troubleshooting Section of the Knight Fire Tube Boiler Service Manual for possible causes and corrective actions.

Table 10A Flue Products Chart

Natural Gas		Propane	
CO ₂	O ₂	CO ₂	O ₂
8.0% - 10.5%	2.1% - 6.6%	9.5% - 11.5%	3.5% - 6.5%

- Once the combustion analysis is complete, test the safety shutoff device by turning the manual shutoff switch to the OFF position and ensuring that the boiler shuts down and registers an alarm. Turn the manual shutoff switch to the ON position and reset the control.
- Turn the main power off to the boiler and re-install the 1/2" combustion plug (FIG. 3-7) or replace the flue temperature sensor into the flue pipe connection.
- Place the boiler back into normal operation.

WARNING

You must replace the flue gas temperature sensor / 1/2" combustion plug (depending on venting option) to prevent flue gas spillage into the room. Failure to comply could result in severe personal injury, death, or substantial property damage.

Set space heating operation

Determine controlling sensor

For space heating systems, the temperature control can be based on one of three sensors; the inlet, outlet, or system supply sensor. The SMART SYSTEM control is programmed at the factory to control the temperature of the outlet sensor. The control will automatically switch to the system supply sensor once it is connected. If it is desired to base the temperature control on the inlet sensor, the appropriate parameter must be changed in the control. See the Knight Fire Tube Boiler Service Manual for a detailed explanation of this procedure.

Verify space heat circulator mode

The Space Heating Mode controls both the system pump (if connected), and the boiler pump. When the SMART SYSTEM control receives a space heating call for heat, it turns on the system pump. If the boiler is not heating an indirect DHW (Domestic Hot Water) tank, and the set point is not met, it also turns on the boiler pump. After the space heating call for heat ends, the system pump continues to run for a short period of time. The system pump can be programmed to run continuously, except during outdoor shutdown. If the boiler pump was running, it continues to run for a short period of time as well. These pump delays are factory set to 30 seconds. If different delays are desired, the appropriate parameters in the control must be changed. See the Knight Fire Tube Boiler Service Manual for a detailed explanation of this procedure.

Adjust set point temperature(s)

NOTICE

Please note that the brackets ([]) denote screen status.

The NAVIGATION dial may be used during normal operation to adjust the space heating and tank set point temperatures.

- From the Status Screen press the NAVIGATION dial.
- Turn the NAVIGATION dial counterclockwise to select the appropriate set point.
- Press the NAVIGATION dial to adjust the temperature.
- Once the desired temperature is displayed, press the RIGHT SELECT [SAVE] key.
- If necessary repeat Steps 3 and 4 to make adjustments to additional set points.
- Press the RIGHT SELECT [HOME] key to upload the changes.
- If the RIGHT SELECT [SAVE] key is not pressed, the new settings will be discarded.

10 Start-up

Set domestic hot water (DHW) operation

Verify DHW mode

There are two (2) modes of operation for DHW. In Normal Mode, when a DHW demand begins, the control will start the DHW pump, turn off the boiler pump (if running), and modulate to bring the outlet temperature to the DHW boiler set point. The maximum firing rate may be limited in this mode if desired.

In Zone Mode it is assumed that the indirect DHW tank is piped as a zone on the primary loop. When a DHW demand begins, the control will turn on the DHW pump output, and raise the system temperature set point to the DHW boiler set point (if higher). The boiler pump will be turned on. The system pump may be forced on, forced off, or not changed, depending on the System Pump Mode selected (reference the Knight Fire Tube Boiler Service Manual for details). In this mode, any low temperature zones (such as radiant heating) may need additional controls to limit the water temperature sent to those zones.

Set DHW boiler target temperature

When in the DHW Mode, the control will modulate to maintain the boiler outlet temperature or system supply temperature to a set point. This set point is set at the factory to 180°F. If a different set point is desired, the appropriate parameter in the control must be changed. See the Knight Fire Tube Boiler Service Manual for a detailed explanation of this procedure.

Set maximum DHW fan speed

If the rated input of the indirect tank is less than the maximum output of the boiler, change the maximum DHW fan speed setting to limit the boiler output accordingly, see the Knight Fire Tube Boiler Service Manual for a detailed explanation of this procedure.

Set clock

NOTICE Please note that the brackets ([]) denote screen status.

The SMART SYSTEM control has a built-in clock that it uses for its night setback feature and for logging events. This clock must be set when the boiler is installed, and anytime the boiler has been powered off for more than 4 hours. Use the following procedure to set the clock:

1. Press and hold the LEFT SELECT [MENU] key for at least 5 seconds.
2. The display changes to read [PASSWORD], with four (4) zeros below it.
3. Press the RIGHT SELECT [SAVE] key.
4. The display will then show a menu with the time, date, and temperature unit.
5. Press the NAVIGATION dial twice.
6. Turn the NAVIGATION dial to adjust the hours. Press the NAVIGATION dial.

7. Turn the NAVIGATION dial to adjust the minutes. Press the NAVIGATION dial.
8. Turn the NAVIGATION dial to adjust the month. Press the NAVIGATION dial.
9. Turn the NAVIGATION dial to adjust the date. Press the NAVIGATION dial.
10. Turn the NAVIGATION dial to adjust the year. Press the RIGHT SELECT [SAVE] key.
11. Press the RIGHT SELECT [HOME] key.

NOTICE The internal clock does not adjust for Daylight Savings Time and therefore, will require a manual adjustment.

The clock is automatically updated whenever a PC is connected and the Win Pro-Installer program is started.

Configuration of the cascade

NOTICE Please note that the brackets ([]) denote screen status.

When installed in a Cascade system, the individual controls must be programmed for cascade operation. This is accomplished by accessing the control parameters.

Press the [MENU] key for at least five (5) seconds. Input the Installer code as described in the Knight Fire Tube Boiler Service Manual. Once the control parameters have been accessed, use the NAVIGATION dial to select the Control Mode parameters. Press the NAVIGATION dial to access these parameters.

Rotate the NAVIGATION dial to select the parameter "Cascade Address". Press the NAVIGATION dial to access this parameter. Each appliance in the Cascade system must be programmed with its own address. The boiler designated as the Leader will have an address of 0. The remaining boilers in the Cascade will be Members and have addresses from 1 - 7. Rotate the NAVIGATION dial to select the appropriate address. Press the RIGHT SELECT [SAVE] key.

Press the RIGHT SELECT [HOME] key to upload the address into the control. Repeat this procedure for all boilers in the Cascade, designating the Leader control and the Member controls.

10 Start-up *(continued)*

Figure 10-4 Operating Instructions

FOR YOUR SAFETY READ BEFORE OPERATING

WARNING: If you do not follow these instructions exactly, a fire or explosion may result causing property damage, personal injury, or loss of life.

- | | |
|--|--|
| <p>A. This appliance does not have a pilot. It is equipped with an ignition device which automatically lights the burner. Do <u>not</u> try to light the burner by hand.</p> <p>B. BEFORE OPERATING smell all around the appliance area for gas. Be sure to smell next to the floor because some gas is heavier than air and will settle on the floor.</p> <p>WHAT TO DO IF YOU SMELL GAS</p> <p>Do not try to light any appliance.</p> <p>Do not touch any electric switch; do not use any phone in your building.</p> | <p>Immediately call your gas supplier from a neighbor's phone. Follow the gas supplier's instructions.</p> <p>If you cannot reach your gas supplier, call the fire department.</p> <p>C. Use only your hand to move the gas control switch. Never use tools. If the switch will not move by hand, don't try to repair it, call a qualified service technician. Force or attempted repair may result in a fire or explosion.</p> <p>D. Do not use this appliance if any part has been under water. Immediately call a qualified service technician to inspect the appliance and to replace any part of the control system and any gas control which has been under water.</p> |
|--|--|

OPERATING INSTRUCTIONS

- | | |
|--|---|
| <ol style="list-style-type: none"> 1. STOP! Read the safety information above on this label. 2. Set the thermostat to lowest setting. 3. Turn off all electric power to the appliance. 4. This appliance is equipped with an ignition device which automatically lights the burner. Do not try to light the burner by hand. 5. Remove front door. 6. Move switch to the "OFF" position. 7. Wait five (5) minutes to clear out any gas. If you then smell gas, STOP! Follow "B" in the safety information above this label. If you don't smell gas, go to next step. | <ol style="list-style-type: none"> 8. Move the switch to the "ON" position. 9. Install front door. 10. Turn on all electric power to appliance. 11. Set thermostat to desired setting. 12. If the appliance will not operate, follow the instructions "To Turn Off Gas To Appliance" and call your service technician or gas supplier. |
|--|---|

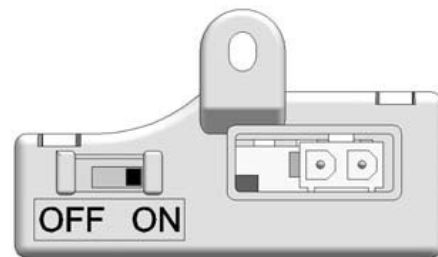

TO TURN OFF GAS TO APPLIANCE

- | | |
|---|--|
| <ol style="list-style-type: none"> 1. Set the thermostat to lowest setting. 2. Turn off all electric power to the appliance if service is to be performed. 3. Remove front door. | <ol style="list-style-type: none"> 4. Move switch the "OFF" position. 5. Install front door. |
|---|--|

11 Operating information

General

How the boiler operates

The AQUAS Fire Tube boiler uses an advanced stainless steel heat exchanger and electronic control module that allows fully condensing operation. It is teamed with an external Cupro Nickel or Titanium straight tube heat exchanger to heat pools and spas. The blower pulls in air and pushes flue products out of the boiler through the heat exchanger and flue piping. The control module regulates blower speed to control the boiler firing rate. The gas valve senses the amount of air flowing into the boiler and allows only the right amount of gas to flow.

How the control module operates

The SMART SYSTEM control module receives inputs from boiler/pool sensors and external devices. The control module activates and controls the blower and gas valve to regulate heat input and switches the boiler, Domestic Hot Water (DHW), and system pumps on and off as needed. The user programs the module to meet system needs by adjusting control parameters. These parameters set operating temperatures and boiler operating modes. Pool heater operation can be based on boiler outlet water temperature, boiler inlet water temperature, system temperature, a 0-10V signal, or ModBus or BACnet, depending on the parameter settings.

Control inputs and outputs

Pool thermostat

There are three (3) heat/loop demand connections available on this control, but only one of the heat/loop demands is used for the AQUAS. This input tells the pool heater to provide water for pool/spa heating.

SMART SYSTEM Multi-temp loop control

The Aquas Fire Tube Pool Heater is capable of controlling two different bodies of water. The main body of water is controlled from Heat/Loop demand 1. If your Aquas is setup to control two bodies of water, the DHW operation is used for the second loop, and the second sensor will tie into the tank thermostat on the low voltage connection board.

0 - 10V input (set point or power)

The AQUAS Fire Tube boiler can be controlled by a Building Management System (BMS) provided that either an external energy management system is installed that reduces the boiler water temperature as the heating load decreases, the boiler is not used for any space heating, or the boiler is part of a modular or multiple boiler system having a total input of 300,000 Btu/hr or greater.

The control can be configured by the installer to use a 0 - 10 Vdc signal to either control set point or firing rate.

The AQUAS Fire Tube boiler can also be programmed to accept a call for heat from a 0 - 10V signal. Reference the Knight Fire Tube Boiler Service Manual for a detailed explanation of this procedure.

DHW/Spa priority

The SMART SYSTEM control allows the connection of a DHW/spa thermostat or tank sensor to the low voltage connection board. When a tank sensor is connected, the DHW/spa thermostat input is ignored. When a pool heater is programmed for DHW/Spa Normal Mode, the maximum firing rate can be limited to match the input rating of the indirect tank coil.

DHW/Spa cycling

If a DHW/spa call for heat is received while a pool heating call is in progress, and the DHW/spa is in Normal Mode, the control will start the DHW/spa pump and shut the boiler pump off. The system pump will remain on. For stand-alone boilers, if the pool heating call is still active while the DHW/spa call is in operation, the control will wait for 30 minutes (time adjustable by installer) then it will switch back to the pool heating demand. There is a timer to switch from pool heating to DHW/spa and a timer to switch from DHW/spa to pool heating. The control will switch back and forth until one of the heat demands end.

Programmable controlling sensor

The control module is programmed to use the outlet sensor as the control sensor by default. If a system supply sensor is connected, the control automatically uses it as the control sensor. For stand-alone boilers, the control sensor can be changed by the installer to the inlet sensor. If the inlet sensor is chosen as the controlling sensor, it is recommended that the system supply sensor be installed in the system supply in order to provide the best control of the inlet temperature.

11 Operating information *(continued)*

Anti-cycling

After the burner turns off, the control will delay the next burner cycle for a set time period (time is adjustable by the installer). The time delay will be bypassed if the inlet water temperature drops too far during the delay.

Boiler and system pump control

The boiler pump will run whenever the burner is firing, unless the DHW/spa is programmed for Normal Mode and the boiler is heating the DHW tank. The boiler pump will run during Freeze Protection Mode as well. It will continue to run for a short time after the burner turns off or the Freeze Protection Mode ends.

The system pump will run whenever there is a pool heating call for heat or the boiler goes into Freeze Protection Mode. It may be programmed to run during a DHW/spa call for heat when the DHW/spa is programmed for Zone Mode. It will continue to run for a short time after the end of the heat demand or the Freeze Protection Mode. The system pump can be programmed to run continuously if desired, except during outdoor shutdown and/or a DHW/spa call for heat.

Temperature control

Modulation

The AQUAS Fire Tube boiler is capable of modulating its firing rate from a minimum of 15% to a maximum of 100%. The firing rate is dictated by the call for heat (i.e., pool heating or domestic hot water), the heating load, ramp delay (if enabled), and various other temperature limitations.

Ramp delay

For systems with lower flow, the SMART SYSTEM can limit the firing rate (when enabled) when a pool heating call for heat starts, or when switching from a DHW call for heat to a pool heating call for heat. There are six (6) limits that can be programmed, as well as six (6) time intervals corresponding to each limit. The sixth limit will also limit the firing rate for the rest of the call for heat.

Gradient limiting

If during operation of the boiler the outlet water temperature is rising too quickly, the control will reduce the firing rate to its lowest setting.

Flame current support

To prevent nuisance shutdowns when the boiler is firing at minimum rates, the control will increase the firing rate when the flame signal drops too low.

11 Operating information

Protection features

Outlet temperature, flue temperature, and temperature rise limiting

The outlet temperature is monitored by the boiler outlet temperature sensor. When the outlet temperature exceeds 104°F, the unit will reduce the fan speed. If the outlet water temperature exceeds 115°F the control will shut the unit down until it cools off.

The control module monitors the flue temperature by a sensor located in the flue exhaust. If the flue temperature exceeds 215°F the control will reduce the maximum fan speed. If the flue temperature exceeds 240°F the control will shut the unit down. The unit will restart automatically once the flue temperature drops 25°F and the minimum off time has expired.

The control monitors the temperature difference between the inlet and the outlet sensor. If this difference exceeds 55°F the control will reduce the maximum fan speed. If the temperature difference exceeds 60°F the control will shut the unit down. The unit will restart automatically once the temperature difference has dropped below 55°F and the minimum off time has expired.

Freeze protection

DO NOT install the boiler in a room likely to freeze.

The following integral feature of the SMART SYSTEM control module provides some protection for the boiler only -- not for the system.

- The SMART SYSTEM control module provides freeze-up protection as follows when the boiler water temperature drops below 45°F:
- Below 45°F, the boiler and system pumps operate constantly.
- Below 37°F, the boiler turns on.
- Boiler and pumps turn off if boiler water temperature rises above 45°F.
- Lower temperatures may be programmed for systems with anti-freeze solutions.

CAUTION

This feature of the SMART SYSTEM control module does not eliminate the possibility of freezing. The installation must still use recognized design, installation, and maintenance practice to prevent freeze potential for the boiler and system.

NOTICE

When system return temperatures are maintained below the dew point, condensation will form on the inside of the boiler jacket causing some internal sheet metal components to rust.

Low voltage blocking

The blower and gas valve require a minimum amount of voltage in order to operate properly. If an ignition attempt is made when the line voltage is temporarily low (such as during a brownout), the control could enter a manual reset lockout. To prevent this, the control monitors the voltage and blocks any heat demands until the voltage returns to an acceptable level.

Monitor external limits

Connections are provided on the connection board for external limits such as flow switch, low water cutoff, gas pressure switches, and a louver proving switch. The SMART SYSTEM will shut off the burner and inhibit relighting whenever any of these external limits open.

Run-time and alarm outputs

The boiler provides dry contacts for indicating when the boiler is running and when it is unable to operate.

Run-time and cycle counting

The control uses two timers to monitor the total hours of burner operation. One timer monitors the time the boiler is firing in the Pool Heating Mode. The other timer monitors the time the boiler is firing in the DHW Mode.

The control uses two (2) ignition counters to monitor the amount of boiler cycles. The first counter counts all ignitions of the control. The second counter counts only ignition attempts that have failed.

Service reminder

The control can be programmed for service reminder notification. This notification will become active when either a set time frame has expired, or a set amount of running hours or cycles has expired (all adjustable by the installer). The display will show a Maintenance Required screen. The installer's name and phone number can be programmed into the control. This information will appear on the Maintenance Required screen. The service reminder notification can be reset or disabled by the installer.

Error logging

The control will hold in memory the last 10 lockouts as well as the last 10 blockings. The date and time of the occurrence will be recorded as well. Only the 10 most current occurrences of each will be held in memory.

11 Operating information *(continued)*

Boiler temperature regulation

Operating temperature (target)

The SMART SYSTEM control module senses water temperature and regulates boiler firing and firing rate to achieve a target temperature. The target temperature can be set between 32°F and 104°F.

- Target temperature is calculated as described in the “*Outdoor Reset Operation*” section, when the outdoor sensor is connected.
- If the outdoor sensor is not connected, the target temperature is fixed at SH (1 - 3) set points. An outdoor sensor fault will remain on the display screen until the outdoor sensor is reconnected.

High limit operations

The AQUAS Fire Tube boiler is equipped with adjustable automatic reset and manual reset high limits. The automatic reset high limit has a maximum set point of 200°F and the manual reset high limit has a maximum set point of 115°F.

When the outlet temperature exceeds 115°F, the automatic high limit action occurs. If the outlet temperature continues to increase, the manual reset high limit action will occur at 115°F.

High limit test procedure

NOTICE

Please note that the brackets ([]) denote screen status.

1. Turn ON the main power to the boiler by placing the ON/OFF switch in the ON position.
2. From the Status Screen, press the NAVIGATION dial to access the Set Points Screen.
3. Press the LEFT SELECT (LIMITS) key.
4. Select the manual reset high limit (MRHL) by rotating the NAVIGATION dial counterclockwise, then press the NAVIGATION dial.
5. Decrease the set point of the MRHL to below the current outlet temperature (or to its minimum setting, whichever is higher) by turning the NAVIGATION dial counterclockwise.
6. Press the RIGHT SELECT [SAVE] key.
7. Press the RIGHT SELECT [HOME] key. The new parameter will upload to the control.
8. If the current outlet temperature is above the new MRHL set point, the MRHL will function causing boiler lockout. If this occurs, skip to Step 11.

9. If the current outlet temperature is below the new MRHL set point, locate the pinhole (SERVICE button) above the RESET button on the display board. Insert a thin probe (such as a paper clip) into the hole and press the button continuously for five (5) seconds to place the boiler into Service Mode. In Service Mode, the boiler will fire at ignition speed and will then modulate up to full fire.
10. Once the outlet temperature rises up to the MRHL set point, the MRHL will function, causing the boiler to shut down and lock out.
11. Repeat Steps 2 - 7 to adjust the MRHL to its normal settings.

Low water cutoff protection

1. The SMART SYSTEM control module uses temperature sensing of both supply and return areas of the heat exchanger. If the flow rate is too low or the outlet temperature too high, the control module modulates and shuts the boiler down. This ensures boiler shutdown in the event of low water or low flow conditions.
2. Some codes and jurisdiction may accept these integral features of the control in lieu of requiring an additional limit control or low water cutoff. Consult local jurisdiction to determine. A low water cutoff is available from the factory (#100173646).

11 Operating information

Cascade

When multiple boilers are installed, they can be wired together in a cascade sequence. A maximum of eight boilers can be controlled from a single control. In this application one boiler would be designated as the Leader control and all others would be designated as Member controls. Member 1 can be configured to take over control of the Cascade should the Leader stop communicating with the members. The Leader control can be programmed to use Lead/Lag or Efficiency Optimization control methods.

Once the Leader boiler receives a call for heat from a thermostat, BMS, or ModBus or BACnet, the control will determine what the set point will be.

Sequence of the cascade

To equalize the run time of all boilers on the Cascade, the firing sequence will automatically be changed at set intervals.

During the first 24 hours of operation, the sequence will change every hour. After that, the sequence will change every 24 hours. The switching on/off sequence will be as follows:

TIME	SWITCHING ON SEQUENCE
Start	L-M1-M2-M3-M4-M5-M6-M7
1 hour	M1-M2-M3-M4-M5-M6-M7-L
2 hours	M2-M3-M4-M5-M6-M7-L-M1

After the first 24 hours, the sequence will change every night at 2:00 a.m. If a boiler locks out or is used to heat an indirect DHW tank, it will automatically be given the lowest priority until 2:00 a.m.

Cascade Multiple Units Together

Temperature Settings

1. SH1 Set Point (Pool Temperature)
2. Minimum SH Set Point (Pool Temperature Minimum)
3. Maximum SH Set Point (Factory Set 104°F)

Control Modes

Cascade

1. Controlling Sensor (Not Applicable)
2. BMS Tstat Input (Active / InActive) (Not Applicable)
3. (Not Applicable)
4. BMS (Active / InActive) (Not Applicable)
5. ModBus (Active / InActive) (Not Applicable)
6. Cascade Address (Leader 0) (Member 1, 2, 3, etc.,)
7. Cascade Type (L/L/EFF)
8. Max Cascade Outlet Set Point
9. Cascade Offset (2°F minimum, this is the warmest the pool will ever be above temperature)
10. Cascade Off / On Differential (This parameter determines how much the temperature must be below the turn off temperature (set point + offset) before the Lead boiler turns on. Four degrees is the tightest this setting can be.
11. Min On / Off Time (Not Applicable)
12. Min Next On Time (Not Applicable)
13. Boiler Size (Not Applicable)

Example: Set Point 78°F
 Offset = 2 Boiler OFF at 80°F
 Differential = 4 Boiler ON at 78°F

11 Operating information *(continued)*

Wiring of the Cascade

When wiring the boilers for Cascade operation, select one boiler as the Leader boiler. The remaining boilers will be designated as Members. See “Configuration of the Cascade” for a detailed explanation of this procedure.

Communication between the Leader boiler and the Member boilers is accomplished by using shielded, 2-wire twisted pair communication cable. Connect one of the twisted pair wires to terminal A on each of the Low Voltage Connection boards (FIG. 8-1), and the other wire of the twisted pair to terminal B on each of the Low Voltage Connection Boards. Connect the shield wires to one of the shield ground terminals on the Low Voltage Connection Boards. If more than two boilers are on the Cascade, daisy chain the wiring from the Sequencing terminals on the second boiler to the Sequencing terminals on the third boiler, then from the third to the fourth, and so on. The connections between boilers can be made in any order, regardless of the addresses of the boilers. Try to keep each cable as short as possible.

Configuration of the Cascade

NOTICE

Please note that the brackets ([]) denote screen status.

When installed in a Cascade system, the individual controls must be programmed for cascade operation. This is accomplished by accessing the control parameters.

Press the [MENU] key for at least five (5) seconds. Input the Installer code as described in the Knight Fire Tube Boiler Service Manual. Once the control parameters have been accessed, use the NAVIGATION DIAL to select the Control Mode parameters. Press the NAVIGATION DIAL to access these parameters.

Rotate the NAVIGATION dial to select the parameter “Cascade Address”. Press the NAVIGATION dial to access this parameter. Each appliance in the Cascade system must be programmed with its own address. The boiler designated as the Leader will have an address of 0. The remaining boilers in the Cascade will be Members and have addresses from 1 - 7. Rotate the NAVIGATION dial to select the appropriate address. Press the RIGHT SELECT [SAVE] key. If installing the boilers in an existing system, the new boilers should be programmed as the Leader and/or the higher number addresses.

Press the RIGHT SELECT [HOME] key to upload the address into the control. Repeat this procedure for all boilers in the Cascade, designating the Leader control and the Member controls.

DHW, Night Setback, and Ramp Delay operation with cascade

For Normal Mode DHW operation any boiler(s) in the Cascade can be selected to provide heat for a DHW call. Select a boiler to be designated as the DHW boiler. Connect the DHW thermostat or sensor to the terminals on the Low Voltage Connection Board marked for the corresponding device. When the boiler receives a DHW call, the Leader control will take that boiler out of the Cascade sequence. If another boiler is available, the Leader will start it up to take its place.

The DHW boiler will adjust its set point to the programmed DHW boiler set point and will adjust its firing rate to maintain this. Once the DHW call has been satisfied, the Leader control will place that boiler back into the Cascade sequence.

Switching of the boiler between DHW operation and SH operation when there is a call for both does not occur in Cascade Mode.













When DHW is programmed for Zone Mode, connect the DHW thermostat or tank sensor to the Leader boiler. When a DHW call is received, the Leader will modulate the entire Cascade to bring the system supply temperature up to the DHW boiler set point (if higher).

Night Setback operation of the boilers within the Cascade is available. Programming of the Night Setback will be done through the Leader boiler. Refer to the Knight Fire Tube Boiler Service Manual for information regarding Night Setback.

Ramp Delay operation of the boilers as described in the Knight Fire Tube Boiler Service Manual is available when the boilers are part of a Cascade system.

11 Operating information

Sequence of operation

OPERATION	DISPLAY
1. Upon a call for heat, the gas pressure switch(es) must be closed.	<p>STANDBY </p> <p>SYSTEM <input type="radio"/> DHW TANK <input type="radio"/></p> <p>BOILER <input type="radio"/> DHW CIRC <input type="radio"/></p> <p>SYSTEM: 117°F (118)</p> <p>TANK: 124°F (130)</p> <p>OUTDOOR: 56°F</p> <p>INLET: 109°F</p> <p>OUTLET: 124°F</p> <p>DHW RECIRC: 115°F</p> <hr/> <p>MENU  SCREEN SHDN</p>
2. Once the gas pressure switch(es) are closed, the control turns on the appropriate pumps (system and boiler pumps for space heating, DHW pump for DHW). The flow switch and/or LWCO must close.	<p>STANDBY </p> <p>SYSTEM <input checked="" type="radio"/> DHW TANK <input type="radio"/></p> <p>BOILER <input checked="" type="radio"/> DHW CIRC <input type="radio"/></p> <p>SYSTEM: 117°F (118)</p> <p>TANK: 124°F (130)</p> <p>OUTDOOR: 56°F</p> <p>INLET: 109°F</p> <p>OUTLET: 124°F</p> <p>DHW RECIRC: 115°F</p> <hr/> <p>MENU  SCREEN SHDN</p>
3. The control turns on power to the louver relay. The louver proving switch, and blocked drain switch must close.	<p>START </p> <p>SYSTEM <input checked="" type="radio"/> DHW TANK <input type="radio"/></p> <p>BOILER <input checked="" type="radio"/> DHW CIRC <input type="radio"/></p> <p>SYSTEM: 117°F (118)</p> <p>TANK: 124°F (130)</p> <p>OUTDOOR: 56°F</p> <p>INLET: 109°F</p> <p>OUTLET: 124°F</p> <p>DHW RECIRC: 115°F</p> <hr/> <p>MENU  SCREEN SHDN</p>
4. The control starts the prepurge cycle by initiating the blower.	<p>PRE-PURGE </p> <p>SYSTEM <input checked="" type="radio"/> DHW TANK <input type="radio"/></p> <p>BOILER <input checked="" type="radio"/> DHW CIRC <input type="radio"/></p> <p>SYSTEM: 117°F (118)</p> <p>TANK: 124°F (130)</p> <p>OUTDOOR: 56°F</p> <p>INLET: 109°F</p> <p>OUTLET: 124°F</p> <p>DHW RECIRC: 115°F</p> <hr/> <p>MENU  SCREEN SHDN</p>
5. The control starts the trial for ignition by firing the spark electrode and opening the gas valve.	<p>IGNITION </p> <p>SYSTEM <input checked="" type="radio"/> DHW TANK <input type="radio"/></p> <p>BOILER <input checked="" type="radio"/> DHW CIRC <input type="radio"/></p> <p>SYSTEM: 117°F (118)</p> <p>TANK: 124°F (130)</p> <p>OUTDOOR: 56°F</p> <p>INLET: 109°F</p> <p>OUTLET: 124°F</p> <p>DHW RECIRC: 115°F</p> <hr/> <p>MENU  SCREEN SHDN</p>
6. If flame is not detected after the sparking ends, the control will perform a postpurge, then start another prepurge cycle and try to light the burner again. The control will perform a total of 4 attempts before locking out.	<p>POST-PURGE </p> <p>SYSTEM <input checked="" type="radio"/> DHW TANK <input type="radio"/></p> <p>BOILER <input checked="" type="radio"/> DHW CIRC <input type="radio"/></p> <p>SYSTEM: 117°F (118)</p> <p>TANK: 124°F (130)</p> <p>OUTDOOR: 56°F</p> <p>INLET: 109°F</p> <p>OUTLET: 124°F</p> <p>DHW RECIRC: 115°F</p> <hr/> <p>MENU  SCREEN SHDN</p>

11 Operating information *(continued)*

Sequence of operation *(continued)*

OPERATION	DISPLAY
<p>7. If flame is detected, it holds the firing rate steady for a few seconds to let the flame stabilize, then it begins to modulate the firing rate based on a set point or some other command (such as a 0-10V BMS signal).</p>	<p style="text-align: center;">41% 🔥 🏠</p> <p>SYSTEM 🔘 DHW TANK ○ BOILER 🔘 DHW CIRC ○ SYSTEM: 117°F (118) TANK: 124°F (130) OUTDOOR: 56°F INLET: 109°F OUTLET: 124°F DHW RECIRC: 115°F</p> <hr/> <p>MENU ⏏️ SCREEN SHDN</p>
<p>8. If the space heating call for heat is active, and the tank thermostat or sensor starts a DHW call for heat, the boiler will switch to the DHW mode. If programmed for normal DHW operation (not as a zone), the DHW pump will turn on first, then the boiler pump will turn off (boiler and DHW pump operation briefly overlap to ensure flow is maintained through the unit). This will divert the boiler's outlet water from the heating system and send it to the tank coil instead. The control will then modulate to maintain the outlet temperature to the DHW boiler set point.</p>	<p style="text-align: center;">41% 🔥 1 🏠</p> <p>SYSTEM 🔘 DHW TANK 🔘 BOILER ○ DHW CIRC ○ SYSTEM: 117°F (118) TANK: 124°F (130) OUTDOOR: 56°F INLET: 109°F OUTLET: 124°F DHW RECIRC: 115°F</p> <hr/> <p>MENU ⏏️ SCREEN SHDN</p>
<p>9. If the boiler is not part of a Cascade, and both the space heating and DHW calls for heat remain active long enough, the boiler will switch back and forth between the two heating modes until one of them is satisfied.</p>	<p style="text-align: center;">41% 🔥 🏠 🏠</p> <p>SYSTEM 🔘 DHW TANK ○ BOILER 🔘 DHW CIRC ○ SYSTEM: 117°F (118) TANK: 124°F (130) OUTDOOR: 56°F INLET: 109°F OUTLET: 124°F DHW RECIRC: 115°F</p> <hr/> <p>MENU ⏏️ SCREEN SHDN</p>
<p>10. Once both calls for heat are satisfied, the control will turn off the burner. The blower will continue to run during the postpurge period.</p>	<p style="text-align: center;">POST-PURGE ANTI-CYCLING</p> <p>SYSTEM 🔘 DHW TANK ○ BOILER 🔘 DHW CIRC ○ SYSTEM: 117°F (118) TANK: 124°F (130) OUTDOOR: 56°F INLET: 109°F OUTLET: 124°F DHW RECIRC: 115°F</p> <hr/> <p>MENU ⏏️ SCREEN SHDN</p>
<p>11. Any pumps that are running will continue to run for their respective pump delay times before turning off, unless programmed to remain on continuously. A 60 second anti-cycle period will start, which will delay any new call for heat until it times out.</p>	<p style="text-align: center;">BLOCKED ANTI-CYCLING</p> <p>SYSTEM 🔘 DHW TANK ○ BOILER 🔘 DHW CIRC ○ SYSTEM: 117°F (118) TANK: 124°F (130) OUTDOOR: 56°F INLET: 109°F OUTLET: 124°F DHW RECIRC: 115°F</p> <hr/> <p>MENU ⏏️ SCREEN SHDN</p>
<p>12. In Standby, ready to start a new cycle.</p>	<p style="text-align: center;">STANDBY</p> <p>SYSTEM ○ DHW TANK ○ BOILER ○ DHW CIRC ○ SYSTEM: 117°F (118) TANK: 124°F (130) OUTDOOR: 56°F INLET: 109°F OUTLET: 124°F DHW RECIRC: 115°F</p> <hr/> <p>MENU ⏏️ SCREEN SHDN</p>

11 Operating information

SMART **SYSTEM**™ AQUAS Fire Tube control module

Use the control panel (FIG. 11-1) to set temperatures, operating conditions, and monitor boiler operation.

Figure 11-1 Control Panel

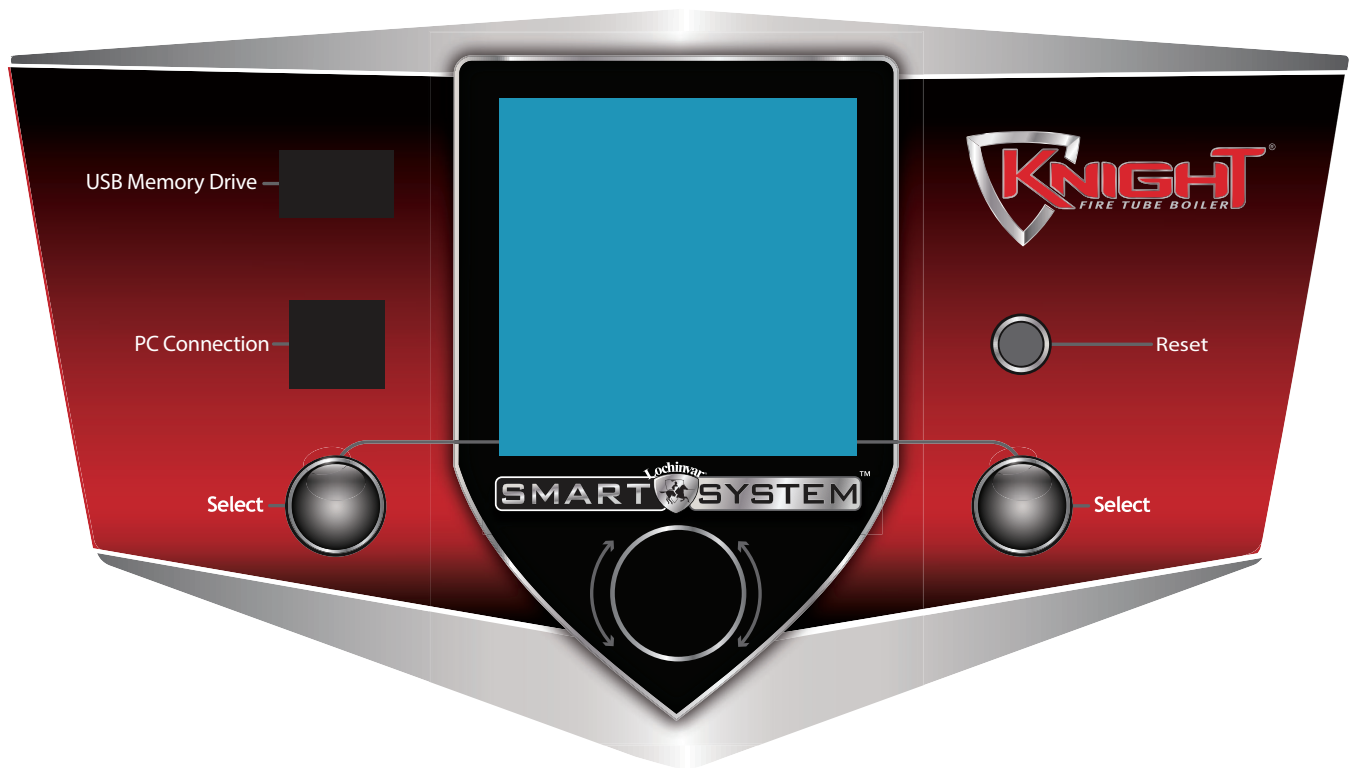

The information on the bottom of the display shows the functions of the two SELECT keys (on either corner), and the NAVIGATION dial (in the center):

MENU = Left SELECT Key









SETPOINTS = NAVIGATION Dial - Pressing Down

SHDN = Right SELECT Key

11 Operating information *(continued)*

Display panel menu access

Table 11A Use this procedure to access menus from the display panel

BUTTON	SCREEN STATUS	OPERATION	DISPLAY
	[SHDN]	Press the RIGHT SELECT soft key [SHDN].	STANDBY OUTLET 117°F INLET 128°F <hr/> MENU ↓SETPOINTS SHDN
	[YES]	Press the LEFT SELECT soft key [YES].	STANDBY SHUTDOWN <hr/> YES _____ NO
	[MENU]	Press and hold the LEFT SELECT soft key [MENU] for five (5) seconds.	STANDBY OUTLET 117°F INLET 128°F <hr/> MENU ↓SETPOINTS SHDN
		Rotate the NAVIGATION dial clockwise until 5 is displayed (first digit on the left).	SHUTDOWN PASSWORD 0000 <hr/> EXIT ↓ NEXT SAVE
		Press the NAVIGATION dial to select the next digit. Rotate the NAVIGATION dial clockwise until 3 is shown in the display.	SHUTDOWN PASSWORD 5000 <hr/> EXIT ↓ NEXT SAVE
		Press the NAVIGATION dial 2 times to move to the last digit. Rotate the NAVIGATION dial counterclockwise until 9 is displayed.	SHUTDOWN PASSWORD 5300 <hr/> EXIT ↓ NEXT SAVE
	[SAVE]	Press the RIGHT SELECT soft key [SAVE].	SHUTDOWN PASSWORD 5309 <hr/> EXIT ↓ NEXT SAVE
		Rotate the NAVIGATION dial counterclockwise to select a category.	SHUTDOWN >GENERAL TEMPERATURE SETTINGS DATA LOGGING FUNCTIONS <hr/> HOME ↵ SCROLL

11 Operating information

Figure 11-2 Status Display Screen

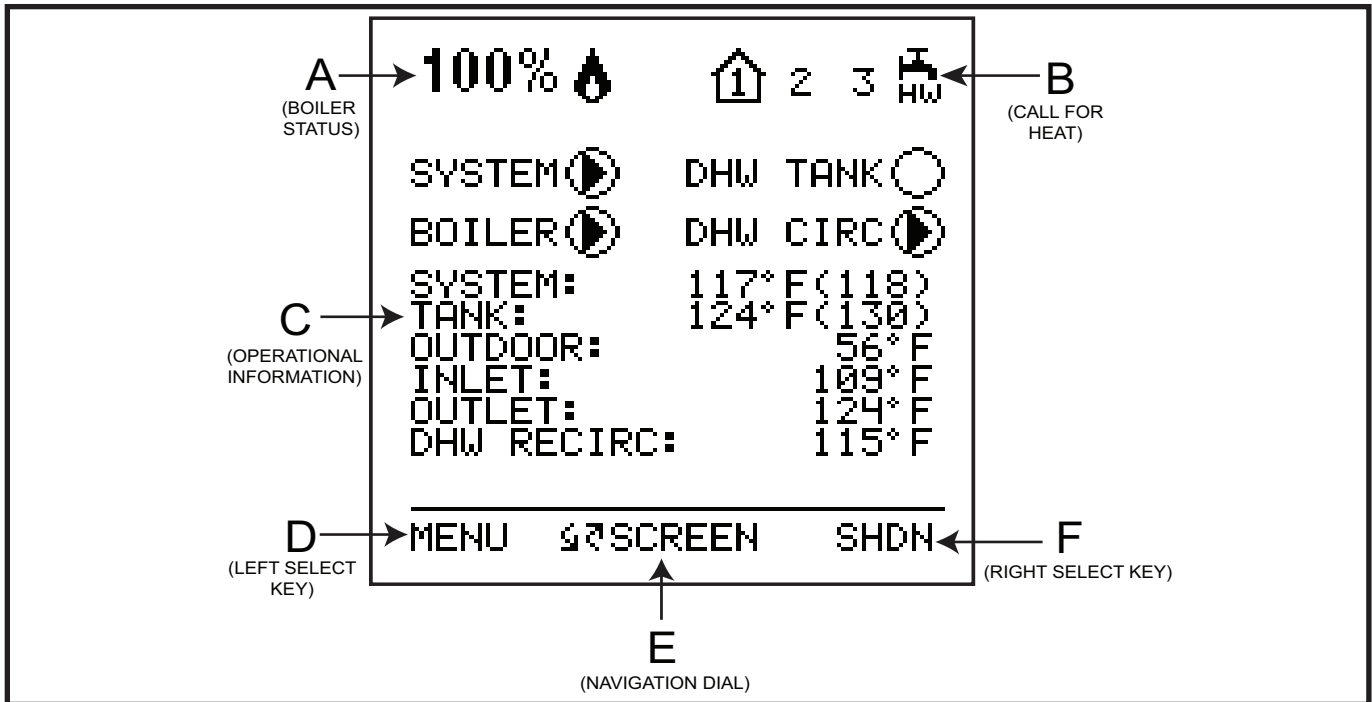

Status Display Screens		
NOTE: All screens show burner status, heat demands, lockout/blocking, pump status, and soft keys.		
Section	Display	Description
A (Boiler Status Bar)	STANDBY	The unit has not received a call for heat from a remote thermostat nor has it received a call for heat from a DHW thermostat.
	START	The unit has begun a burn cycle and is checking all safety circuits.
	PREPURGE	The unit has initiated a prepurge period on a call for heat.
	IGNITION	The unit has begun a spark period to ignite the main burner.
	% 🔥	The unit has fired and is running at the displayed percentage.
	POSTPURGE	The call for heat has been satisfied and the unit runs the fan for an additional postpurge period to clear the combustion chamber and vent system of residual flue products.
	SHUTDOWN	The unit has been placed in the OFF position.
	SETPOINT MET	The controlled temperature has exceeded its set point and its offset.
	BLOCKED	The unit has detected a condition that has temporarily interrupted the current call for heat.
B (Call for Heat Indicators)	1	Room Thermostat 1 has a call for heat.
	2	Room Thermostat 2 has a call for heat.
	3	Room Thermostat 3 has a call for heat.
	HW	The tank thermostat or sensor has a call for heat.
	① ② ③	Indicates which room thermostat demand has priority.
	Ⓜ	The unit is being controlled by a 0 - 10V BMS signal.
	Ⓒ	The member unit is supplying heat while in Cascade Mode.

11 Operating information *(continued)*

Status Display Screens *(cont'd)*

NOTE: All screens show burner status, heat demands, lockout/blocking, pump status, and soft keys.

Section	Display	Description
C (Operational Information)	DETAILS SCREEN 1	a. SYSTEM TEMP b. TANK TEMP c. OUTDOOR TEMP d. INLET TEMP e. OUTLET TEMP f. DHW RECIRC TEMP - The temperature read by the DHW recirculation sensor (if connected).
	DETAILS SCREEN 2	a. DELTA T b. FLUE TEMP c. FLAME CURRENT d. FAN SPEED e. LOOP 1 TEMP - The temperature of Loop 1 reported by the MTLC control. f. LOOP 2 TEMP - The temperature of Loop 2 reported by the MTLC control. g. LOOP 3 TEMP - The temperature of Loop 3 reported by the MTLC control.
	I/O SCREEN	a. GAS PRESS SW - The state of the gas pressure switch. b. FLOW SW - The state of the flow switch. c. LOUVER RELAY - The state of the louver relay output. d. LOUVER SW - The state of the louver proving switch. e. BLOCKED DRAIN - The state of the blocked drain switch. f. GAS VALVE - The state of the gas valve output.
	BMS SCREEN	a. 0 - 10V BMS IN b. 0 - 10V RATE OUT c. BMS ADDRESS d. BMS CONTROL? e. SYS PUMP SPEED f. BLR PUMP OUT
	HISTORY SCREEN	a. SH RUN TIME - Total time running for Space Heat (SH). b. SH CYCLES - Total Space Heat (SH) demand cycles. c. DHW RUN TIME - Total time running for DHW. d. DHW CYCLES - Total DHW demand cycles. e. POWER TIME - Total time powered ON. f. IGNITIONS - Total number of successful ignitions. g. IGN ATTEMPTS - Total number of ignition attempts.
	LAST 10 FAULTS	a. FAULT NO. b. FAULT c. DATE d. TIME

11 Operating information

Status Display Screens (cont'd)		
NOTE: All screens show burner status, heat demands, lockout/blocking, pump status, and soft keys.		
Section	Display	Description
C (Operational Information cont.)	CASCADE STATUS	a. CASCADE STATUS b. CASCADE POWER c. PRESENT
	NIGHT SETBACK	a. TRIGGER 1 - Next Space Heat (SH) night setback trigger. b. TRIGGER 2 - Next DHW night setback trigger.
D (LEFT SELECT key function)	USB	Press the LEFT SELECT key to access the USB and Installer menu.
E (NAVIGATION dial function)	MODIFY	Pressing the NAVIGATION dial will allow the installer to change the text.
F (RIGHT SELECT key function)	SHDN	Press the RIGHT SELECT key to turn the boiler OFF.
	ON	Press the RIGHT SELECT key to turn the boiler ON.
	NO	Press the RIGHT SELECT key to cancel the shutdown operation.
	SAVE	Press the RIGHT SELECT key to save the current change.
	HOME	Press the RIGHT SELECT key to return to the Status Screen and upload parameter changes.

12 Maintenance

Maintenance and annual startup

Table 12A Service and Maintenance Schedules

		Service technician (see the following pages for instructions)	Owner maintenance (see the Knight Fire Tube User's Information Manual for instructions)
ANNUAL START-UP	General:	<ul style="list-style-type: none"> • Address reported problems • Inspect interior; clean and vacuum if necessary; • Clean condensate trap and fill with fresh water • Check for leaks (water, gas, flue, condensate) • Verify flue and air lines in good condition and sealed tight • Check system water pressure/system piping/expansion tank • Check control settings • Check ignition and flame sense electrodes (sand off any deposits; clean and reposition) • Check wiring and connections • Perform start-up checkout and performance verification per Section 10 of this manual. • Flame inspection (stable, uniform) • Flame signal (at least 10 microamps at high fire) • Clean the heat exchanger if flue temperature is more than 54°F above return water temperature. 	<ul style="list-style-type: none"> • Check boiler area • Check pressure / temperature gauge
	ANNUAL START-UP	General:	Daily
	ANNUAL START-UP	If combustion or performance indicate need:	Monthly
	ANNUAL START-UP	General:	Periodically
	ANNUAL START-UP	If combustion or performance indicate need:	Every 6 months
			End of season months

12 Maintenance

⚠ WARNING

Follow the service and maintenance procedures given throughout this manual and in component literature shipped with the boiler. Failure to perform the service and maintenance could result in damage to the boiler or system. Failure to follow the directions in this manual and component literature could result in severe personal injury, death, or substantial property damage.

⚠ WARNING

The boiler should be inspected annually only by a qualified service technician. In addition, the maintenance and care of the boiler designated in Table 12A and explained on the following pages must be performed to assure maximum boiler efficiency and reliability. Failure to service and maintain the boiler and system could result in equipment failure.

⚠ WARNING

Electrical shock hazard – Turn off power to the boiler before any service operation on the boiler except as noted otherwise in this instruction manual. Failure to turn off electrical power could result in electrical shock, causing severe personal injury, or death.

Address reported problems

1. Inspect any problems reported by the owner and correct before proceeding.

Inspect boiler area

1. Verify that boiler area is free of any combustible materials, gasoline, and other flammable vapors and liquids.
2. Verify that air intake area is free of any of the contaminants listed in Section 1 of this manual. If any of these are present in the boiler intake air vicinity, they must be removed. If they cannot be removed, reinstall the air and vent lines per this manual and the Knight Fire Tube Boiler Service Manual.

Inspect boiler interior

1. Remove the front access cover and inspect the interior of the boiler.
2. Vacuum any sediment from inside the boiler and components. Remove any obstructions.

Clean condensate trap

1. Inspect the condensate drain line, condensate PVC fittings, and condensate trap.

Flush condensate trap with water

1. Remove the four (4) screws securing the top cover to the condensate trap and remove the cover (FIG. 12-1).
2. Locate the plastic ball inside the float tube. Verify there is nothing under the ball causing it to not seat properly.
3. Fill with fresh water until the water begins to pour out of the drain.
4. Ensure the top gasket is seated properly. Replace the top cover and the screws removed in Step 1.

Figure 12-1 Condensate Trap

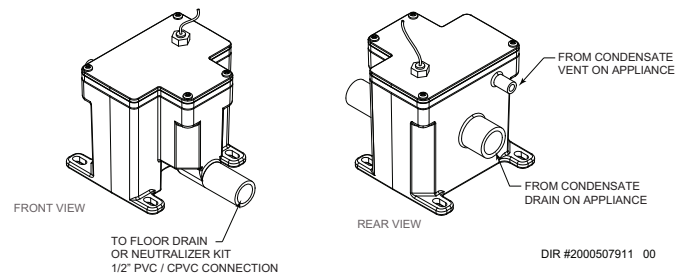

Check all piping for leaks

⚠ WARNING

Eliminate all system or boiler leaks. Continual fresh makeup water will reduce boiler life. Minerals can build up in sections, reducing heat transfer, overheating heat exchanger, and causing heat exchanger failure. Leaking water may also cause severe property damage.

1. Inspect all water and gas piping and verify to be leak free.
2. Look for signs of leaking lines and correct any problems found.
3. Check gas line using the procedure found in Section 7 - Gas Connections.

12 Maintenance *(continued)*

Flue vent system and air piping

1. Visually inspect the entire flue gas venting system and air piping for blockage, deterioration or leakage. Repair any joints that show signs of leakage. Verify that air inlet pipe is connected and properly sealed.
2. Verify that boiler vent discharge and air intake are clean and free of obstructions.

WARNING Failure to inspect for the above conditions and have them repaired can result in severe personal injury or death.

Check water system

1. Verify all system components are correctly installed and operational.
2. Check the cold fill pressure for the system. Verify it is correct (must be a minimum of 12 psi).
3. Watch the system pressure as the boiler heats up (during testing) to ensure pressure does not rise too high. Excessive pressure rise indicates expansion tank sizing or performance problem.
4. Inspect automatic air vents and air separators. Remove air vent caps and briefly press push valve to flush vent. Replace caps. Make sure vents do not leak. Replace any leaking vents.

Check expansion tank

1. Expansion tanks provide space for water to move in and out as the heating system water expands due to temperature increase or contracts as the water cools. Tanks may be open, closed or diaphragm or bladder type.

Check boiler relief valve

1. Inspect the relief valve and lift the lever to verify flow. Before operating any relief valve, ensure that it is piped with its discharge in a safe area to avoid severe scald potential. Read Section 6 - Hydronic Piping before proceeding further.

WARNING Safety relief valves should be re-inspected AT LEAST ONCE EVERY THREE YEARS, by a licensed plumbing contractor or authorized inspection agency, to ensure that the product has not been affected by corrosive water conditions and to ensure that the valve and discharge line have not been altered or tampered with illegally. Certain naturally occurring conditions may corrode the valve or its components over time, rendering the valve inoperative. Such conditions are not detectable unless the valve and its components are physically removed and inspected. This inspection must only be conducted by a plumbing contractor or authorized inspection agency – not by the owner. Failure to re-inspect the boiler relief valve as directed could result in unsafe pressure buildup, which can result in severe personal injury, death, or substantial property damage.

WARNING Following installation, the valve lever must be operated AT LEAST ONCE A YEAR to ensure that waterways are clear. Certain naturally occurring mineral deposits may adhere to the valve, rendering it inoperative. When manually operating the lever, water will discharge and precautions must be taken to avoid contact with hot water and to avoid water damage. Before operating lever, check to see that a discharge line is connected to this valve directing the flow of hot water from the valve to a proper place of disposal. Otherwise severe personal injury may result. If no water flows, valve is inoperative. Shut down the boiler until a new relief valve has been installed.

2. After following the above warning directions, if the relief valve weeps or will not seat properly, replace the relief valve. Ensure that the reason for relief valve weeping is the valve and not over-pressurization of the system due to expansion tank waterlogging or undersizing.

12 Maintenance

Inspect ignition and flame sense electrodes

1. Remove the ignition and flame sense electrodes from the boiler heat exchanger access cover.
2. Remove any deposits accumulated on the ignition/flame sense electrode using sandpaper. If the electrodes cannot be cleaned satisfactorily, replace with new ones.
3. Replace ignition/flame sense electrode, making sure gasket is in good condition and correctly positioned.

Check ignition ground wiring

1. Inspect boiler ground wire from the heat exchanger access cover to ground terminal strip.
2. Verify all wiring is in good condition and securely attached.
3. Check ground continuity of wiring using continuity meter.
4. Replace ground wires if ground continuity is not satisfactory.

Check all boiler wiring

1. Inspect all boiler wiring, making sure wires are in good condition and securely attached.

Check control settings

1. Set the SMART SYSTEM control module display to Parameter Mode and check all settings. See Section 1 of Knight Fire Tube Boiler Service Manual. Adjust settings if necessary. See Section 1 of the Knight Fire Tube Boiler Service Manual for adjustment procedures.
2. Check settings of external limit controls (if any) and adjust if necessary.

Perform start-up and checks

1. Start boiler and perform checks and tests specified in Section 10 - Start-up.
2. Verify cold fill pressure is correct and that operating pressure does not go too high.

Check burner flame

1. Inspect flame through observation window.
2. If the flame is unsatisfactory at either high fire or low fire, turn off boiler and allow boiler to cool down. Remove the burner and clean it thoroughly using a vacuum cleaner or compressed air. Do not use compressed air to clean burner if performed inside a building.
3. Remove the burner, reference FIG. 13-2 below.
4. When replacing the burner, ensure gasket is in good condition and positioned correctly (FIG. 13-2).

Figure 12-2 Burner Assembly

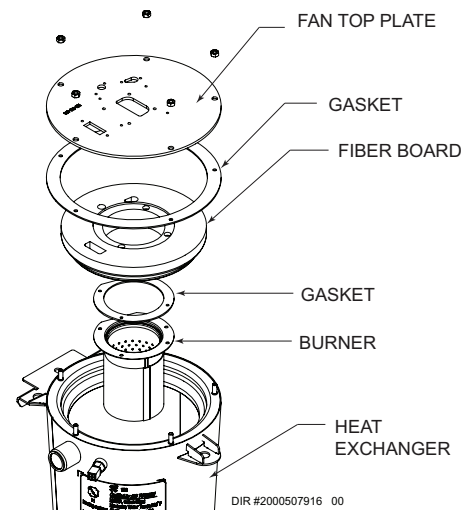

Check flame signal

1. At high fire the flame signal shown on the display should be at least 10 microamps.
2. A lower flame signal may indicate a fouled or damaged flame sense electrode. If cleaning the flame sense electrode does not improve, ground wiring is in good condition, and ground continuity is satisfactory, replace the flame sense electrode.
3. See Section 3 - Troubleshooting of the Knight Fire Tube Boiler Service Manual for other procedures to deal with low flame signal.

12 Maintenance *(continued)*

Review with owner

1. Review the Knight Fire Tube Boiler User's Information Manual with the owner.
2. Emphasize the need to perform the maintenance schedule specified in the Knight Fire Tube Boiler User's Information Manual (and in this manual as well).
3. Remind the owner of the need to call a licensed contractor should the boiler or system exhibit any unusual behavior.
4. Remind the owner to follow the proper shutdown procedure and to schedule an annual start-up at the beginning of the next heating season.

Pool Heat Exchanger Maintenance

To maintain a pool system, the pool heat exchanger must be regularly cleaned and leak free. A system that is not cleaned regularly can have a major impact on system efficiency.

Cleanliness is usually an internal (waterside) tube concern, and problems typically occur due to scale buildup and particulate deposits. This can result in loss of unit performance due to heat transfer problems and tube failure. Follow the procedure below to clean the pool heat exchanger.

1. Turn OFF power and gas supply to the boiler. Allow the boiler and water in the system to cool before proceeding.
2. Close the gate valve to the pool heat exchanger. Turn OFF makeup water to the boiler.
3. Relieve the pressure on the boiler side of the pool heat exchanger by pulling the drain plug. Place the bolt to the side for use in reassembly.
4. Relieve the pressure on the tube sheet/pool side of the heat exchanger by loosening the bolts that secure the two CPVC flanges together.

Loosen the bolts that secure the CPVC bonnets to the aluminum shell to gain access to the tube sheet and place them aside for use in reassembly. Four (4) gaskets must be replaced after this process. Refer to the replacement parts list for the appropriate gasket(s).

5. Loosen both unions on the top of the heat exchanger to isolate it from the boiler piping. Remove the two bolts from the two part heat exchanger brackets to remove the heat exchanger.
6. Remove the tube sheet from the shell by sliding it to the left or right end of the shell. The sheet may be removed after one of the ends breaks free.
7. Visually inspect the tube sheet for wear or damage. A size 3 or size 4 cleaning brush is required to clean the heat exchanger.
8. Submerge the entire tube sheet vertically in a tub of water. Ensure that each tube is cleaned using this process, even if no clogs are present.
9. Reassemble the unit in reverse order of part removal.
10. If there is a bolt pattern in reassembly that contains four (4) or more bolts, follow a bolting pattern tightening sequence and follow the torque factor when tightening.
11. Refer to Table 6A on page 36 of this manual for recommended system water flow settings.
12. Perform a combustion analysis by following the instructions in Section 10 - Startup - Check Flame and Combustion on pages 56 and 57 of this manual.
13. Resume operation.



WARNING

The boiler contains ceramic fiber materials. Use care when handling these materials per instructions in the Service Manual. Failure to comply could result in severe personal injury.



CAUTION

Damaged gaskets and seals in the system can result in substantial property damage. Ensure that damaged or torn gaskets are replaced.

Figure 12-3 Pool Heat Exchanger

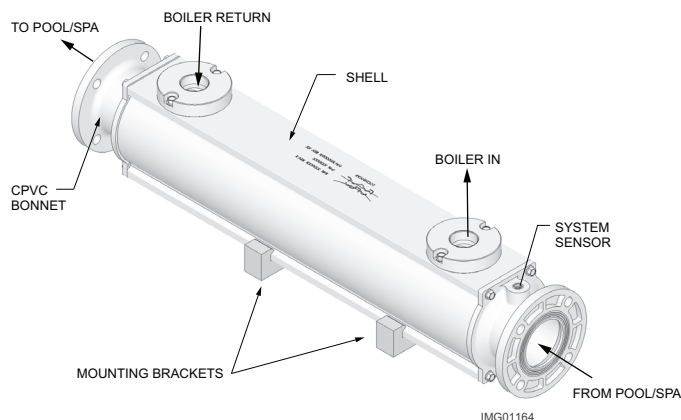

13 Diagrams

Figure 13-1 Ladder Diagram

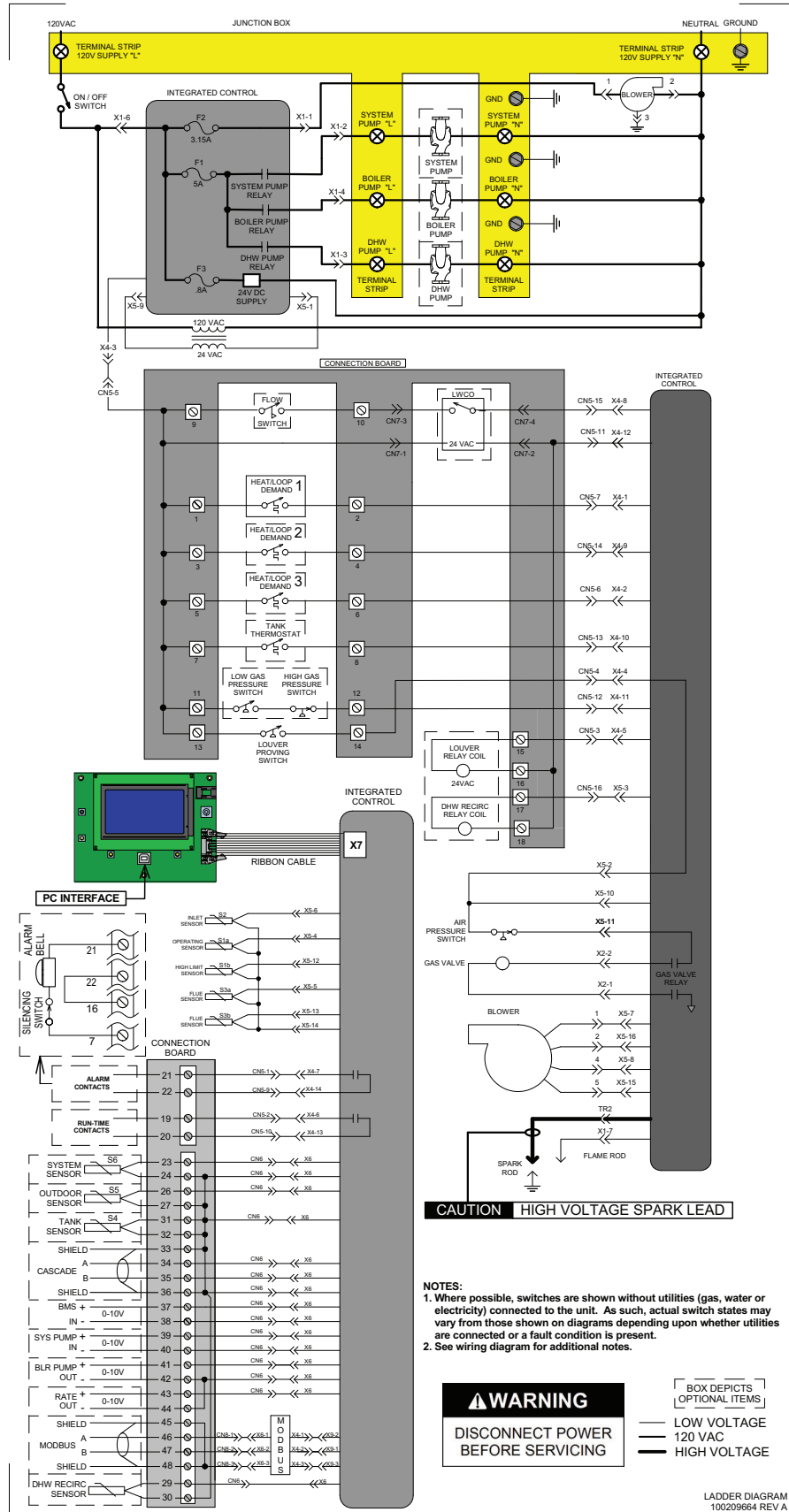

13 Diagrams *(continued)*

Figure 13-2 Wiring Diagram

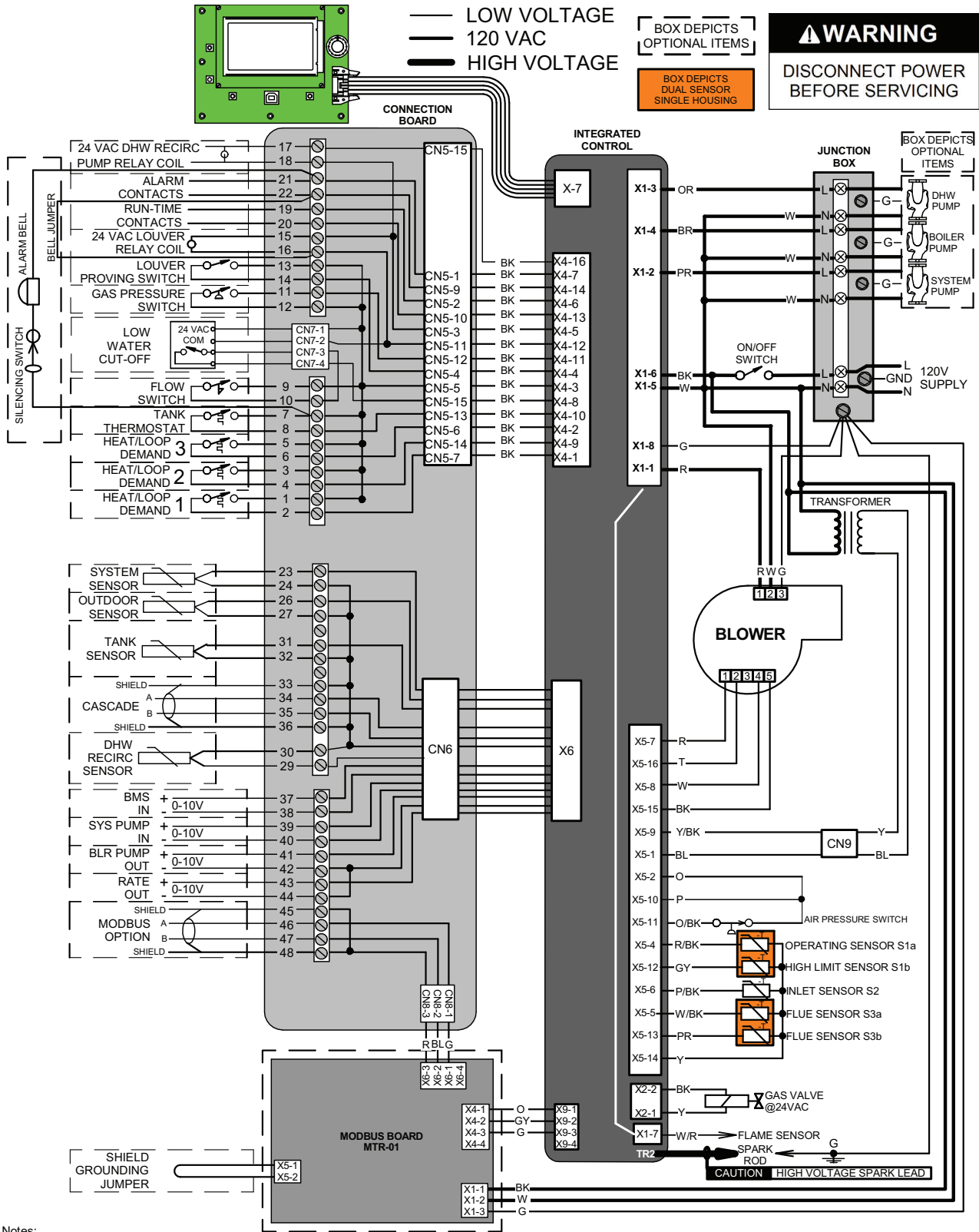

Notes:

1. All wiring must be installed in accordance with: local, state, provincial and national code requirements per either N.E.C. in USA or C.S.A. in Canada.
2. If any original equipment wire as supplied with the appliance must be replaced, it must be replaced with wire having same wire gauge (AWG) and rated for a minimum of 105°C. Exceptions: Replacement high voltage spark lead and ribbon cables must be purchased from the factory. Use of a non-approved spark lead or ribbon cables can lead to operational problems which could result in non-repairable damage to the integrated controller or other components.
3. Actual connector block locations may vary from those shown on diagrams. Refer to actual components for proper connector block locations when using diagrams to troubleshoot unit.

Revision Notes: *Revision A (PCP# 300005197 / CN# 500005965) initial release.*

Revision B (PCP #3000044010 / CN #500031602) reflects an update to FIG. 8-1.