

AQUAS POOL PACKAGE INSTALLATION INSTRUCTIONS

FOR MODELS: APN400 - 850

AQUAS Pool Package

The AQUAS pool package system is a high efficiency commercial condensing boiler, pre-piped package system from the factory to an indirect heat exchanger. This pool heater is a low temperature operating system designed to take advantage of the stainless steel heat exchanger and condensing operating temperatures to ensure the highest efficiency possible. The AQUAS is designed around a predetermined flow set by the manufacturer between the boiler and the indirect heat exchanger. The AQUAS operates off the pool system pump itself which will continually supply water to the indirect heat exchanger. This means there is no need to purchase a dedicated circulator to deliver water to this package system.

Installation Instructions

To achieve the optimum operating efficiency of your AQUAS it is recommended that you keep the pool water flow of each appliance within plus or minus five gallons per minute of the recommended flow as stated in Table A. Low flow through the indirect heat exchanger will result in elevated temperatures supplied to the pool.

TABLE A		
MODEL	RECOMMENDED SYSTEM WATER FLOW	CONNECTION SIZE
400	52 GPM	2"
500	65 GPM	2"
600	78 GPM	2"
725	94 GPM	2"
850	90 GPM	2"

RECOMMENDED CLEARANCES:

BOILER - SEE FTXL I & O MANUAL

INDIRECT HEX - ALLOW 18" FOR SERVICE ON ALL SIDES

Piping

Pool / spa connections to the indirect heat exchanger are SCH 80 CPVC glue fittings. The connections from the field loop to the heat exchanger may be done in CPVC or PVC pipe as follows:

- Use a cement that is rated for PVC/CPVC piping.
- To make the connection, apply glue to both the CPVC flange and the section of pipe.
- Insert the pipe into the flange until it reaches the bottom of the flange.
- Turn the pipe a half turn in the socket to ensure that a proper seal is made.

Pool water is designed to flow from bottom to top standing in front of the boiler. The field installed sensor is to be on the inlet of the heat exchanger.

The supply and return water piping to the indirect heat exchanger shall be no smaller than 2" for all models.

Throttling Valve

A ΔT of 15°F - 20°F across the indirect heat exchanger is recommended. Throttling valves are used to set the flow through the indirect heat exchanger (standard gate valves are acceptable).

Figure 1 Component Location

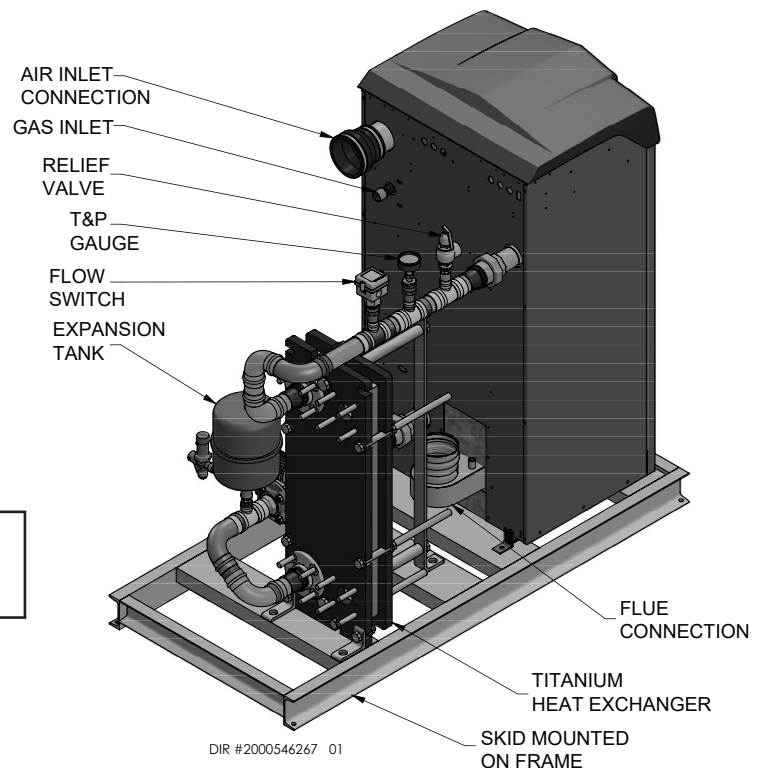

The system can be installed in either a Full Flow or Diverted Flow orientation:

Full Flow (reference FIG. 8)

If the total system flow of the swimming pool or spa system is within five gallons per minute of the recommended system water flow as shown in Table A on page 1, this type of system is recommended.

Diverted Flow (reference FIG.'s 9 & 10)

Criteria for installing a diverted flow system is as follows:

- If the total system flow is greater than the amount required by the indirect heat exchanger.
- Installations with temperatures in excess of 95°F. This is necessary so the pool high limit will not trip. No water should enter the pool / spa in excess of 115°F. If the heat exchanger pool outlet is in excess of 115°F the water must be tempered down.
- Multiple unit installation.

Example: Total system flow is 500 gallons per minute (GPM). If two AQUAS Pool Packages (850,000 Btu/hr) were installed, each of the pool packages would require 90 GPM for a total of 180 GPM of the pool water being diverted through the indirect heat exchangers while the other 320 GPM would be diverted back to the pool.

Safety High Limit Requirements

Ensure that the 115°F safety high limit control is installed in the filter system piping. Install the high limit a minimum of three feet downstream from the point where the heated water from the indirect heat exchanger is added to the filtration system (see FIG.'s 8 - 10). If the water leaving the heat exchanger is in excess of 115°F a bypass must be installed to temper the water below 115°F before re-entering the pool/spa.

The high limit will be mounted in a 3/8" NPT tapped fitting installed in the filtration system piping or it may be installed directly into a tapped opening in the PVC filter system piping. Turn off the filter system pump when installing the high limit in the filtration system piping. Tapped openings can be added to the PVC pipe by first drilling 9/16" pilot holes in the PVC pipe at least three feet downstream of the point where the heated water from the indirect heat exchanger is added to the filter piping. The drilled pilot holes can now be carefully threaded with a 3/8" NPT tap. After the pipe threads have been cut into the PVC pipe wall the high limit can be inserted into the tapped openings.

Apply a small amount of a high quality RTV silicone sealant to the threads to prevent leaks and install the limit into the threaded opening in the pipe. Install the limit control and tighten to seal. Do not over tighten into the threaded opening in the PVC pipe. Over tightening can damage the parts and/or strip the threads cut into the plastic pipe. Wire the 115°F limit into the pool heater control circuit as shown in FIG. 2 on page 3. If additional wire length is needed, use 18 gauge wire for distances up to 30 feet. For longer distances, size the wire per Table B.

TABLE B Remote Wire Connection	
WIRE GAUGE	MAXIMUM ALLOWABLE LENGTH
12 GA	100 ft.
14 GA	75 ft.
16 GA	50 ft.
18 GA	30 ft.

Figure 2 Low Voltage Connections

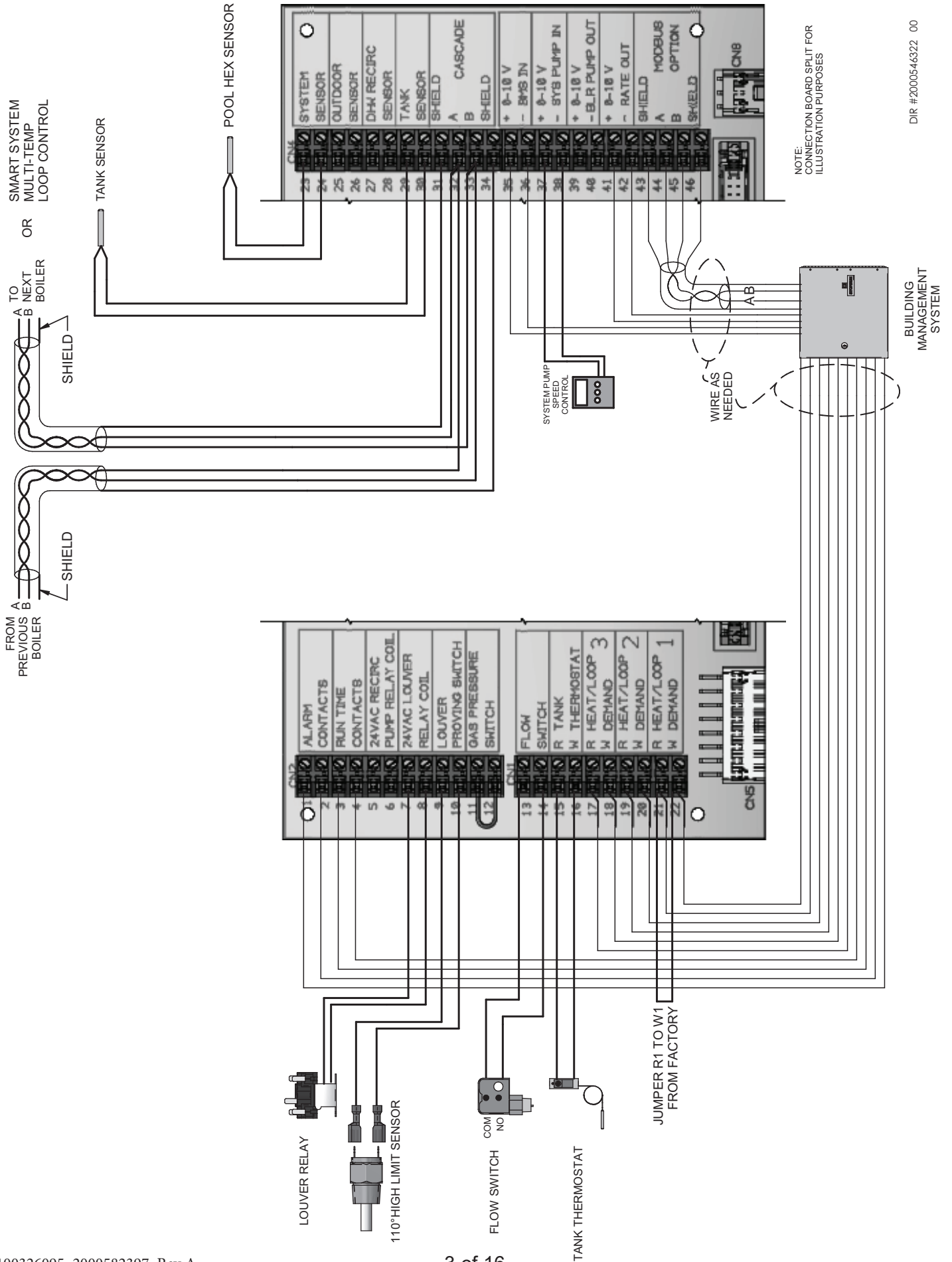

Line Voltage Connections

The AQUAS pool package has a single point line voltage connection for the boiler and the pump (FIG. 3). Connect 120 VAC wiring to the line voltage terminal strip in the junction box. Provide and install a fused disconnect or service switch (15 amp recommended) as required by local codes. Refer to Table C for total amps by model.

TABLE C					
Model	400	500	600	725	850
Total Amps	<12	<12	<12	<12	<12

Figure 3 Line Voltage Field Wiring Connections

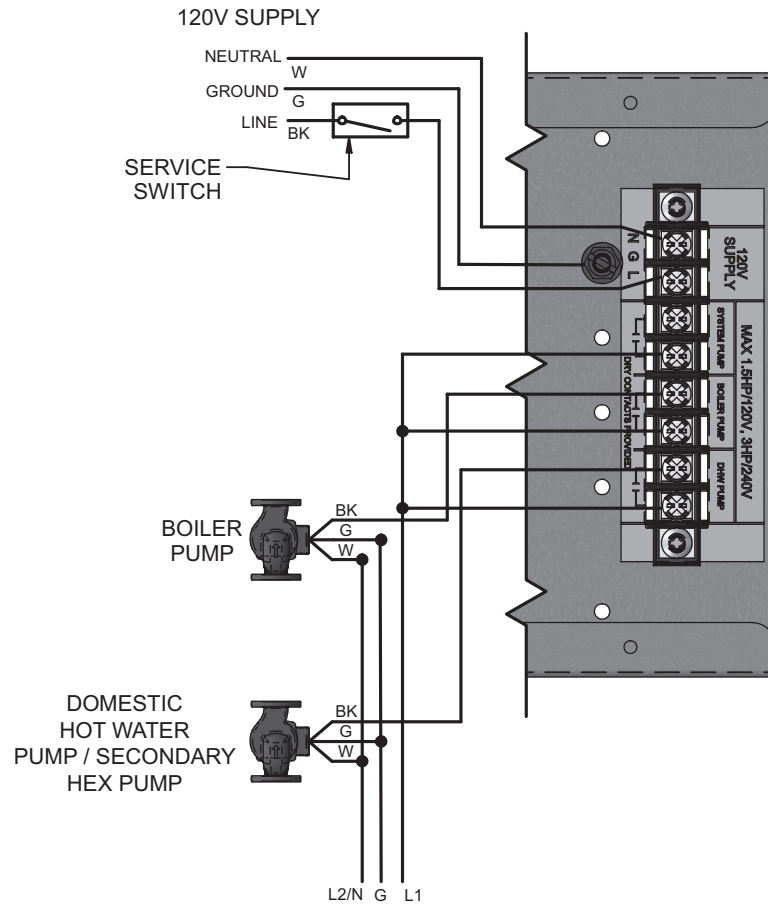

Indirect Heat Exchanger

Installation Instructions

Heat exchangers should be installed downstream of the pumping and filtration equipment (reference FIG. 4).

Figure 4 Pumping and Filtration Equipment

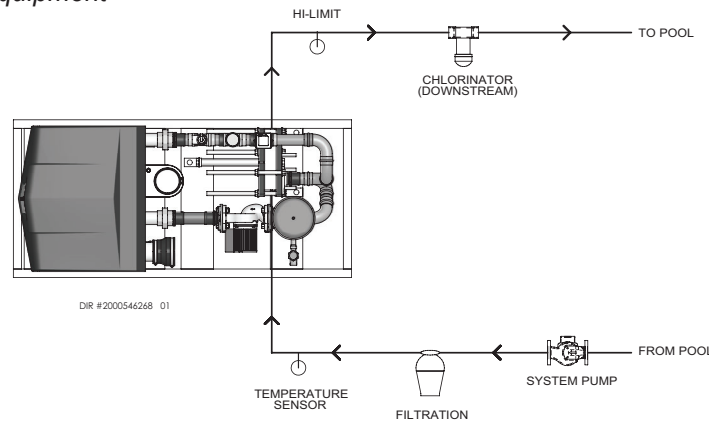

Pool Water Chemistry

It is essential that the instructions in this section along with the Ryznar Stability Index and/or Calcium Stability Index are followed to prevent corrosion / erosion of the indirect heat exchanger:

- Always keep pH to within correct levels. The ideal pool pH should be kept to within 7.4 to 7.6.
- Under no circumstances should the pH fall below 7.2 or rise above 7.8 (see FIG. 5). Check on a day-to-day basis. Alter pool condition as necessary.
- Ensure that chlorine levels are within the range recommended by the chemical manufacturer and are in accordance with the type of pool, for example; private, hotel, school or municipal.
- If a bypass is fitted to the indirect heat exchanger circuit, it is essential that any or all of the valves are correctly positioned to allow the recommended pool water flow to pass through the heat exchanger.
- The system filter unit should be checked regularly, especially sand filters (to detect sand and diatomaceous earth). Sand filters, if working incorrectly, can allow sand to pass around the pool circuit causing erosion of the pipework and heat exchanger. Keep the pool free from debris such as leaves, grass cuttings, etc. This foreign matter can cause decay and increase pH.
- It is essential that the correct amount of chlorine dosage is added to the pool. To allow proper dispersion of the dose in the pool water, distribute the chemicals to various areas of the pool. Do not dose in one area only, as this will create high acidic areas which can cause corrosion / erosion of the pool equipment.

- Chlorinators must feed downstream of the pool heater and have an anti-siphoning device to prevent chemical backup in the heater when the pump is shut off.

CAUTION

High chemical concentrations from improperly adjusted feeders, chlorinators or salt levels above 5000 ppm can cause rapid corrosion to the heat exchanger.

Filling the System

The boiler is filled through the pressure reducing auto-fill valve. The operating pressure of this system is 15 psi between the heater and the indirect heat exchanger. There are no adjustments necessary to the fill valve cartridge (factory set). The expansion tank is set at 20 psi. It is necessary to check the pressure of the expansion tank when annual maintenance is performed. The boiler system operates off a city or potable water system which feeds a closed loop system. A hard line is piped from the potable water supply to the pressure reducing valve. This water is to remain on at all times when the system is in operation.

Pressure Reducing Valve

The valve is equipped with a fast-fill feature that can be used to override normal operation when filling and purging the system. To activate fast-fill, push and hold down the fast-fill knob on top of the cartridge as shown in FIG. 6.

Relieve air from the system through operation of the pressure relief valve by pulling the lever on top of the valve, causing it to open.

Figure 5 pH Scale

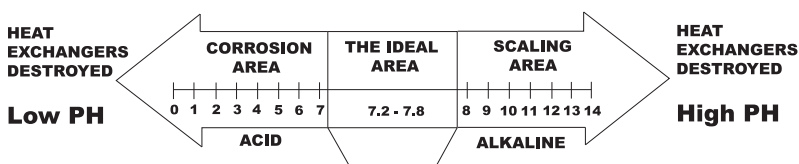
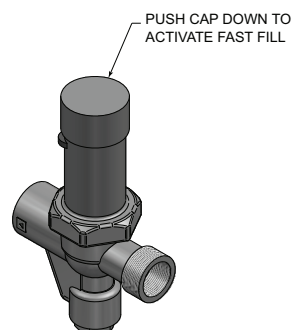

Figure 6 Pressure Reducing Auto-Fill Valve



Makeup Water Assembly

NOTICE

In the following steps, a backup wrench is necessary to properly attach the makeup water assembly.

1. Attach the brass reducer tee to the expansion tank as shown in FIG. 7.
2. Attach the assembly to the AQUAS system.
3. Attach the brass nipple to the brass tee as shown in FIG. 7.
4. Attach the makeup water fill valve to the open end of the brass nipple.

Figure 7 Connecting the Makeup Water Assembly

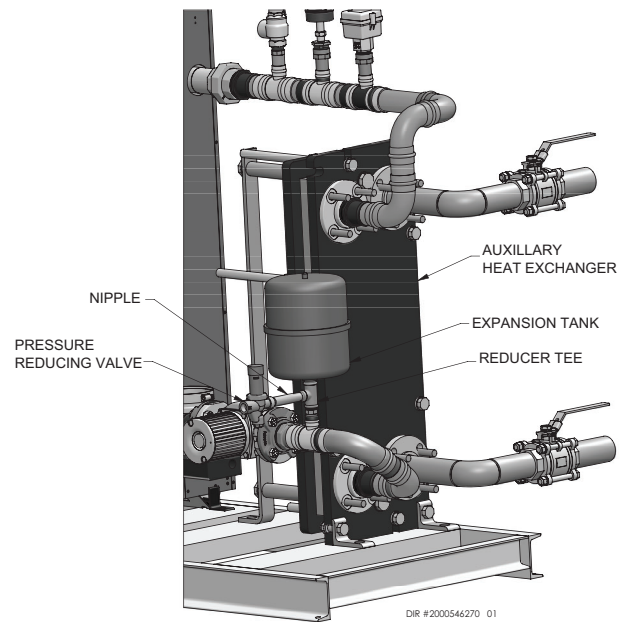
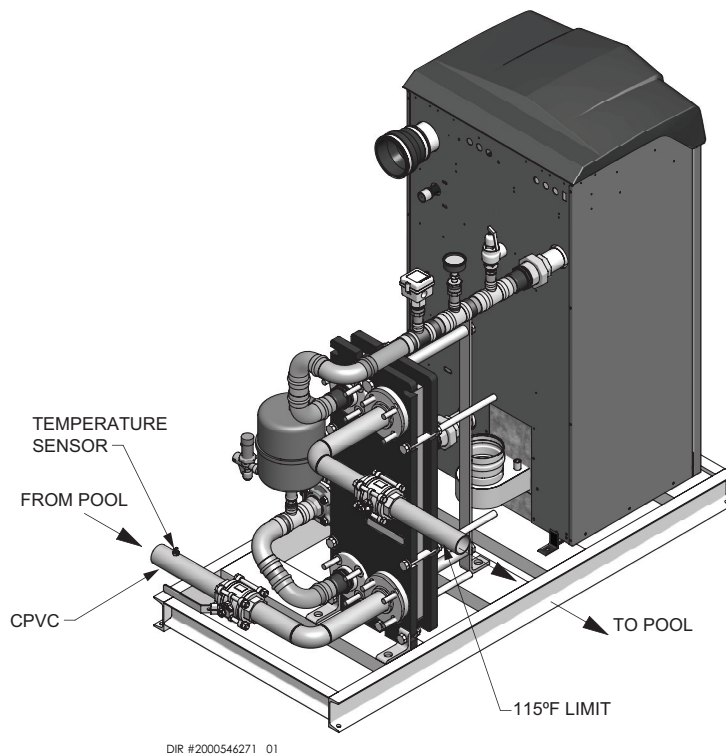

Figure 8 Full Flow



NOTICE

Please note that these illustrations are meant to show system piping concept only, the installer is responsible for all equipment and detailing required by local codes.

Figure 9 Bypass (if flow is greater than required by heat exchanger)

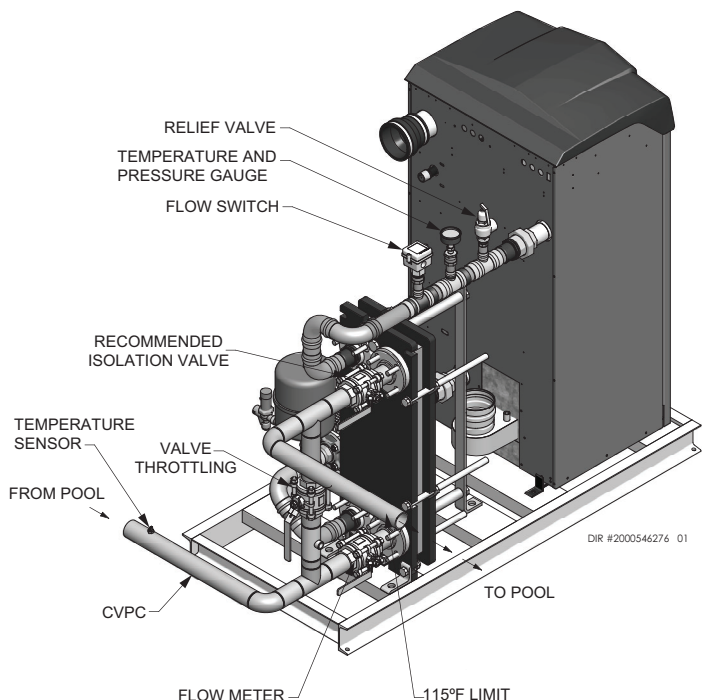

NOTICE Adjust valves to provide suggested flow per Table A on page 1.

Figure 10 Bypass Multiple Units (if flow is greater than required by heat exchanger)

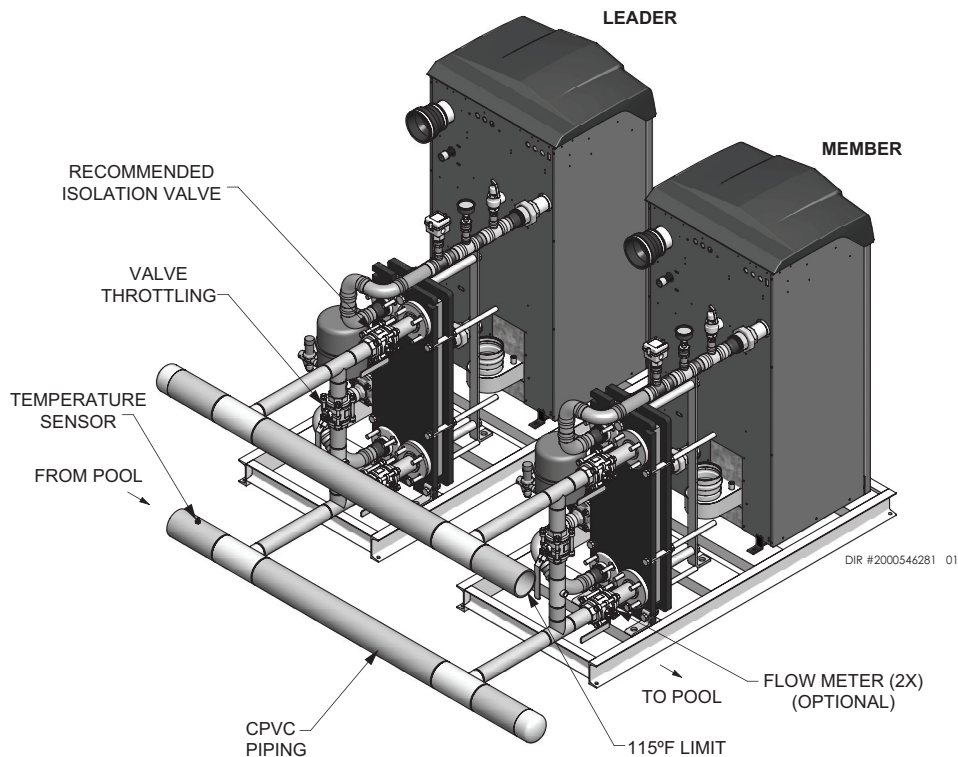

NOTICE Please note that these illustrations are meant to show system piping concept only, the installer is responsible for all equipment and detailing required by local codes.

NOTICE System flow should always remain higher than the required flow for the boiler(s) when the boiler(s) is in operation to prevent short cycling and high limit issues.

AQUAS Pool Setup

To access the Installer setting press and hold the Menu/Exit key until it requires the installer's code. Proceed and enter #5309 (reference Table D on page 11).

NOTE: NA = No adjustment necessary.

Standalone Operation

Temperature Settings

1. SH1 Set Point (Pool Temperature)
2. Minimum SH Set Point (Pool Temperature Minimum)
3. Maximum SH Set Point (Factory Set 104°F)
4. SH1 Offset (2°F Minimum) number of degrees above the set point the boiler will turn off.
5. SH1 differential (4°F Minimum) number of degrees below the turn off temperature the boiler must see before the boiler will turn on.

Example: Set Point 78°F
Offset = 2 *Boiler OFF at 80°F*
Differential = 4 *Boiler ON at 76°F*

Cascade Multiple Units Together

Temperature Settings

1. SH1 Set Point (Pool Temperature)
2. Minimum SH Set Point (Pool Temperature Minimum)
3. Maximum SH Set Point (Factory Set 104°F)

Control Modes

Cascade

1. Controlling Sensor (Not Applicable)
2. BMS Tstat Input (Active / InActive) (Not Applicable)
3. (Not Applicable)
4. BMS (Active / InActive) (Not Applicable)
5. ModBus (Active / InActive) (Not Applicable)
6. Cascade Address (Leader 0) (Member 1, 2, 3, etc.,)
7. Cascade Type (L/L/EFF) See the FTXL I & O Manual for description and settings.
8. Max Cascade Outlet Set Point
9. Cascade Offset (2°F minimum, this is the warmest the pool will ever be above temperature)
10. Cascade Off/ On Differential (This parameter determines how much the temperature must be below the turn off temperature (set point + offset) before the Lead boiler turns on. Four degrees is the tightest this setting can be.
11. Min On / Off Time (Not Applicable)
12. Min Next On Time (Not Applicable)
13. Boiler Size (Not Applicable)

Example: Set Point 78°F
Offset = 2 *Boiler OFF at 80°F*
Differential = 4 *Boiler ON at 78°F*

Cascade

When multiple boilers are installed, they can be wired together in a cascade sequence. A maximum of eight boilers can be controlled from a single control. In this application one boiler would be designated as the Leader control and all others would be designated as Member controls.

If the water temperature at the inlet side of the indirect heat exchanger sensor is less than the set point + the turn-off offset - the off-on differential, then the control will initiate a call for heat on the Cascade (see the FTXL Service Manual for an explanation of the offset and differential). The Leader will energize the lead boiler on the Cascade. For a new startup this will be the Leader boiler.

The boiler will fire at its ignition speed and will then modulate its firing rate to maintain the set point. If the first boiler reaches 100% of its firing rate, the Leader will calculate at what point the second boiler could fire at 20% of its firing rate. At this point, the Leader will fire the second boiler on the Cascade. For a new startup, this would be the first Member boiler. The boiler will fire at its ignition speed and will then modulate its firing rate to maintain the set point.

If the set point still cannot be met, the Leader will continue firing more Members until either the heat demand is met or all boilers on the Cascade are firing. As the heat demand decreases, the last boiler on will modulate down to 20% of its firing rate. Once the demand for that boiler is zero, it will shut down. As the heat demand decreases further, the second to last boiler will modulate down and shut off. This will continue until the demand is satisfied and all boilers are shut off.

Wiring of the Cascade

When wiring the boilers for Cascade operation, select one boiler as the Leader boiler. The remaining boilers will be designated as Members. See “Configuration of the Cascade” for a detailed explanation of this procedure.

Communication between the Leader boiler and the Member boilers is accomplished by using shielded, 2-wire twisted pair communication cable. Connect one of the twisted pair wires to terminal A on each of the Low Voltage Connection boards (FIG. 3), and the other wire of the twisted pair to terminal B on each of the Low Voltage Connection Boards. Connect the shield wires to one of the shield ground terminals on the Low Voltage Connection Boards. If more than two boilers are on the Cascade, daisy chain the wiring from the Sequencing terminals on the second boiler to the Sequencing terminals on the third boiler, then from the third to the fourth, and so on. The connections between boilers can be made in any order, regardless of the addresses of the boilers. Try to keep each cable as short as possible.

Configuration of the Cascade

NOTICE

Please note that the brackets ([]) denote screen status.

When installed in a Cascade system, the individual controls must be programmed for cascade operation. This is accomplished by accessing the control parameters.

Press the [MENU] key for at least five (5) seconds. Input the Installer code as described in the FTXL Service Manual. Once the control parameters have been accessed, use the NAVIGATION DIAL to select the Control Mode parameters. Press the NAVIGATION DIAL to access these parameters.

Rotate the NAVIGATION dial to select the parameter “Cascade Address”. Press the NAVIGATION dial to access this parameter. Each appliance in the Cascade system must be programmed with its own address. The boiler designated as the Leader will have an address of 0. The remaining boilers in the Cascade will be Members and have addresses from 1 - 7. Rotate the NAVIGATION dial to select the appropriate address. Press the RIGHT SELECT [SAVE] key. If installing the boilers in an existing system, the new boilers should be programmed as the Leader and/or the higher number addresses.

Press the RIGHT SELECT [HOME] key to upload the address into the control. Repeat this procedure for all boilers in the Cascade, designating the Leader control and the Member controls.

SMART SYSTEM™ AQUAS control module

Use the control panel (FIG. 11) to set temperatures, operating conditions, and monitor boiler operation.

Figure 11 Control Panel

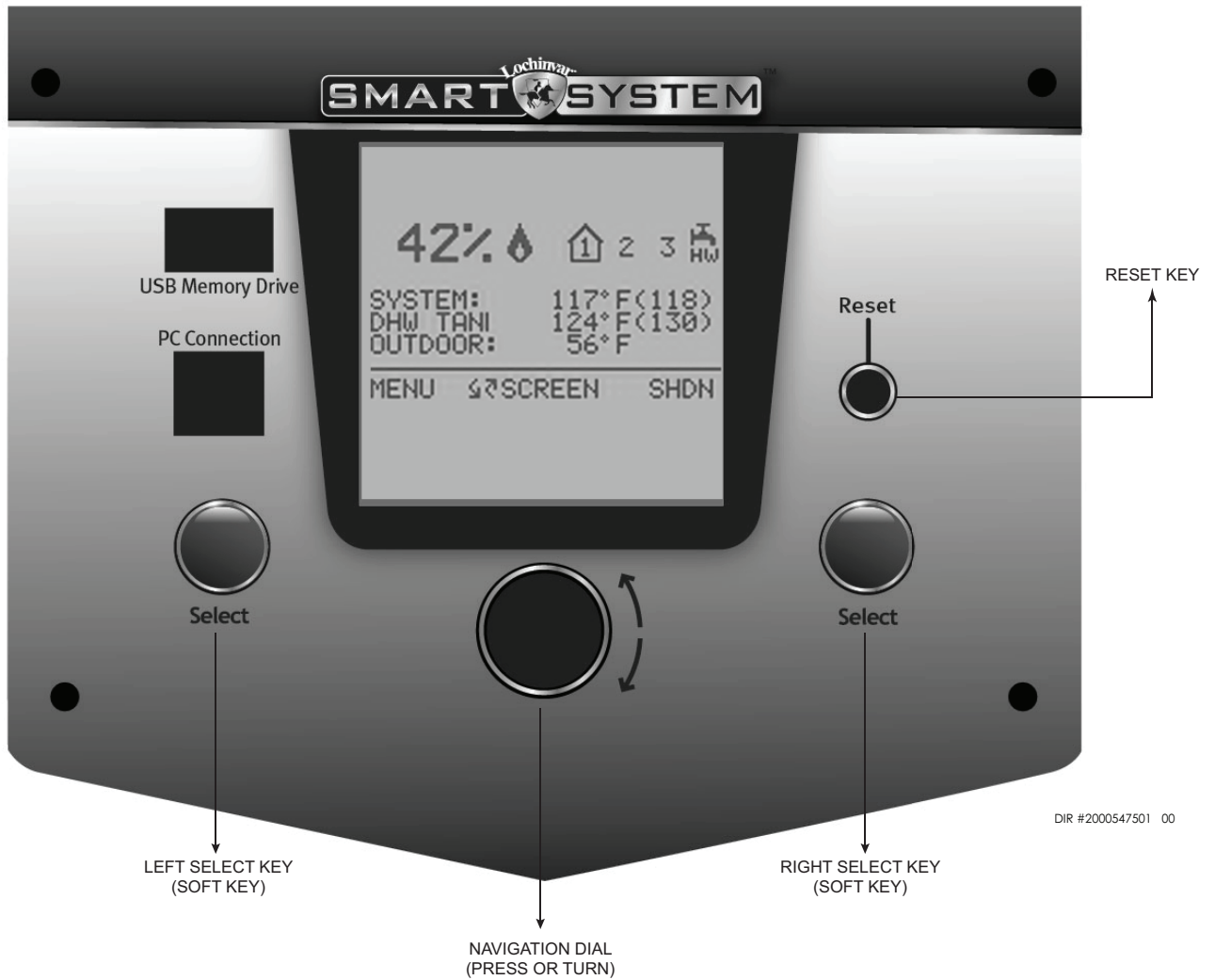









The information on the bottom of the display shows the functions of the two SELECT keys (on either corner), and the NAVIGATION dial (in the center):

- MENU = Left SELECT Key
- SET POINTS = NAVIGATION Dial - Pressing Down
- SHDN = Right SELECT Key

Display panel menu access

Table D Use this procedure to access menus from the display panel

BUTTON	SCREEN STATUS	OPERATION	DISPLAY
	[SHDN]	Press the RIGHT SELECT soft key [SHDN].	STANDBY OUTLET 117°F INLET 128°F <hr/> MENU ↓SETPOINTS SHDN
	[YES]	Press the LEFT SELECT soft key [YES].	STANDBY SHUTDOWN <hr/> YES _____ NO
	[MENU]	Press and hold the LEFT SELECT soft key [MENU] for five (5) seconds.	STANDBY OUTLET 117°F INLET 128°F <hr/> MENU ↓SETPOINTS SHDN
		Rotate the NAVIGATION dial clockwise until 5 is displayed (first digit on the left).	SHUTDOWN PASSWORD 0000 <hr/> EXIT ↓NEXT SAVE
		Press the NAVIGATION dial to select the next digit. Rotate the NAVIGATION dial clockwise until 3 is shown in the display.	SHUTDOWN PASSWORD 5000 <hr/> EXIT ↓NEXT SAVE
		Press the NAVIGATION dial 2 times to move to the last digit. Rotate the NAVIGATION dial counterclockwise until 9 is displayed.	SHUTDOWN PASSWORD 5300 <hr/> EXIT ↓NEXT SAVE
	[SAVE]	Press the RIGHT SELECT soft key [SAVE].	SHUTDOWN PASSWORD 5309 <hr/> EXIT ↓NEXT SAVE
		Rotate the NAVIGATION dial counterclockwise to select a category.	SHUTDOWN >GENERAL TEMPERATURE SETTINGS DATA LOGGING FUNCTIONS <hr/> HOME ↵ SCROLL

Pool Heat Exchanger Maintenance

WARNING To avoid hand injuries from sharp edges, protective gloves should always be worn when handling plates and protective sheets.

WARNING If the heat exchanger is hot, wait until it has cooled down to about 104°F (40°C).

Opening the heat exchanger

1. Drain the plate heat exchanger.
2. Inspect the sliding surfaces of the carrying bar and wipe clean.
3. Mark the outside of the plate assembly with a diagonal line to facilitate proper reassembly (FIG. 12).

Figure 12 Mark Location on Plate Assembly

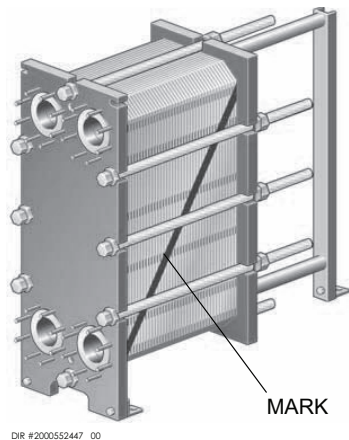

4. Measure and make note of dimension A (FIG. 13).
5. Loosen and remove all bolts except for the four (4) bolts at the positions indicated below. Use the remaining four (4) bolts to open the plate pack according to the following scheme:

Step	Bolt Number	To Dimension
1	1-2-3-4	1.05A
2	1-2 or 3-4	Opening

NOTE: Ensure that the plate and pressure plate are always in parallel. Skewing the pressure plate during opening must not exceed 10 mm (2 turns per bolt) across the width and 25 mm (5 turns per bolt) vertically.

Figure 13 Measure Across the Plate Assembly

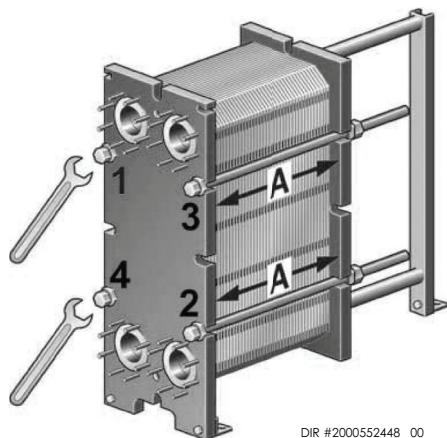

6. Open the plate pack by letting the pressure plate glide on the carrying bar. If plates are to be numbered, do this before removing the plates. Plates need not be removed if cleaning is done using water only (i.e., without cleaning agent).

WARNING The plate pack may still contain a small residual amount of liquid after draining. Depending on the type of product and type of installation, special arrangements may be necessary to avoid damages to personnel and equipment (e.g., drainage box).

Manual cleaning of the heat exchanger

1. Remove deposits from the plates using a soft brush and running water.
NOTE: Plate removal is not required if deposits are removable by water and a brush.
2. Rinse with water using a high pressure hose.
3. If deposits are not removable with water and a brush, the plates must be removed from the plate heat exchanger. Brush the plates with a cleaning agent and rinse with water.

NOTICE Be careful not to damage the gasket during manual cleaning.

Table E Cleaning Agents - Incrustation, Scaling

Incrustation - Scaling	Sediment	Cleaning Agent
Calcium	Corrosion products	Nitric acid
Calcium sulphate	Metal oxides	Sulfamic acid
Silicates	Silt	Citric acid
	Alumina	Phosphoric acid
	Diatom organisms and their excrement of various colors	Complexing agents (EDTA, NTA), Sodium polyphosphates
Concentration Max 4%		
Temperature Max 140°F (60°C)		

Table F Cleaning Agents - Biological Growth, Slime

Biological Growth - Slime	Cleaning Agent
Bacteria	Sodium hydroxide
Nematodes	Sodium carbonate
Protozoa	Cleaning effect can be considerably increased by the addition of small quantities of hypochlorite or agents for the formation of complexes and surfactants.
Concentration Max 4%	
Temperature Max 176°F (80°C)	

Table G Cleaning Agents - Oil Residues, Asphalt, Fats

Deposit	Cleaning Agent
Oil residues Asphalt Fats	Paraffinic naphta-based solvent (e.g., kerosine) NOTE: Gaskets made of EPDM rubber swell in these materials. Contact time should be limited to 30 minutes.

CAUTION

The following solutions should not be used:

- Ketones (e.g., Acetone, Methyletylketone, Methylisobutylketone)
- Esters (e.g., Ethylacetate, Butylacetate)
- Halogenated hydrocarbons (e.g. Chloro-thene, Carbon tetrachloride, Freons)
- Aromatics (e.g., Benzene, Toulene)

Closing the heat exchanger

1. Ensure that all sealing surfaces are clean.
2. Use a steel wire brush to clean the threads of the bolts. Lubricate the threads using a thin layer of grease.
3. Attach gaskets to the plates and ensure that all gaskets are properly attached.
4. Insert the plates with the herringbone pattern positioned in alternating directions and with the gaskets turned towards the frame plate.
5. Press the plate assembly together. Follow the two-step process below to tighten the plate assembly. Ensure that the frame plate and pressure plate are always parallel.

Step	Bolt Number	To Dimension
1	1-2 or 3-4	1.10A
2	1-2-3-4	A

Tighten the two (2) diagonal pairs of bolts alternately until the plate package measures 1.10A (FIG. 14). Tighten the middle pair of bolts and the upper and lower bolts.

NOTICE

The actual measurement must never be less than Dimension A (FIG. 13).

Pressure test after maintenance

Whenever plates or gaskets have been removed, inserted, or exchanged, it is strongly recommended to perform a pressure test to confirm the internal and external sealing functions of the PHE before starting-up the unit. During this test, one side must be tested at a time with the other side open to the atmosphere.

Pressure testing should be performed at a pressure equal to the operating pressure of the actual unit, but never above the design pressure as stated on the nameplate.

The recommended test time is 10 minutes.

Please note that PHE units for refrigeration applications and units with media that will not mix with water must be dried after hydrostatic pressure testing.

Please consult the local office / representative of the supplier for advice on the pressure testing procedure.

Figure 14 Tighten the Bolts

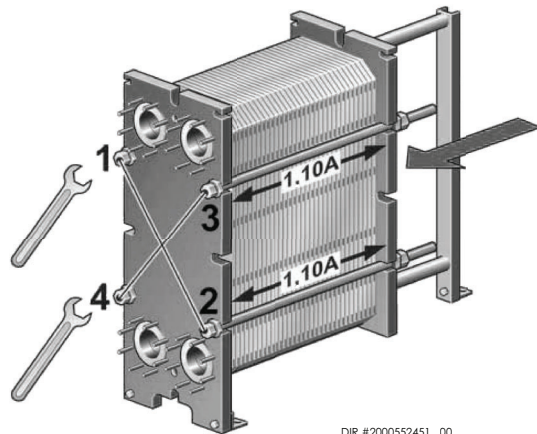

DIR #2000552451 00

Secondary Heat Exchanger / Domestic Hot Water

This system received factory installed secondary tapings for Domestic Hot Water (DHW) or Spa operation. The heat exchanger kits listed in Table H include all the necessary parts to install the secondary heat exchanger in the field. Piping is not included with this package and should be field-supplied. Flow charts are provided in FIG.'s 16 thru 19 so that a pump may be properly sized for the system. Use the connection points indicated for DHW operation on the boiler. Reference Fig. 15 for an Secondary piping illustration.

TABLE H - Heat Exchanger Data							
Heat Exchanger	Btu/hr Input Range		Shell Connection	Boiler Flow	Pool Connection	Tube Sheet	
	MIN	MAX				Min	Max
100061682	80,000	130,000	1"	21	1.5"	25	66
100147366	100,000	260,000	1"	25	1.5"	35	93
100147368	120,000	415,000	1.25"	37	2"	50	127
100147369	140,000	640,000	2"	42	3"	93	330

DHW/Spa (Domestic Hot Water) Thermostat

Connect the storage indirect water heater (DHW) thermostat (FIG. 2, page 3) to the DHW thermostat terminals on the connection board following the loop diagram. Failure to do so may result in premature failure in DHW/Spa system. When the tank sensor is connected the thermostat is ignored (see *DHW/Spa tank sensor*).

DHW/Spa tank sensor

By installing a tank/spa sensor, the SMART SYSTEM control can perform the tank thermostat function. The SMART SYSTEM control automatically detects the presence of this sensor and generates a DHW/Spa call for heat when the tank temperature drops 2°F (1°C) below the tank setpoint. The SMART SYSTEM control then finishes the call for heat when the tank temperature reaches the tank/spa setpoint. The tank sensor included with the Squire® indirect DHW tanks (100208545) is the only sensor suitable for use with the SMART SYSTEM control. Connect the sensor leads to the tank sensor terminals on the low voltage connection board (FIG. 2).

WARNING

Failure to use the correct sensor may result in the tank temperature being either above or below the setpoint. If thermistors are not compatible with the indirect tank/spa, a tank thermostat can be used to control the boiler. The tank thermostat should be installed per the manufacturer's instructions and wired to the DHW/Spa thermostat terminals on the low voltage connection board.

Spa sensor

The spa sensor (100208552) must be looped with the 115°F Pool Sensor (100073321) on the low voltage connection board (FIG. 2). On the low voltage connection board use terminals 21 & 22 for Pool operation and terminals 26 & 27 (Tank Sensor) for Spa operation.

Start-up

Set domestic hot water (DHW/Spa) operation

Verify DHW/Spa mode

There are two modes of operation for DHW. In "Normal Mode" when a DHW/Spa demand begins, the control will start the DHW/Spa pump, turn off the boiler pump (if running) and modulate to bring the outlet temperature to the DHW/Spa boiler set point. The maximum firing rate may be limited in this mode if desired.

In "Zone Mode" it is assumed that the indirect DHW/Spa tank is piped as a zone on the primary loop. When a DHW/Spa demand begins, the control will turn on the DHW/Spa pump output and raise the system temperature set point to the DHW/Spa boiler set point (if higher). The boiler pump will be turned on. The system pump may be forced on, forced off, or unchanged depending on the system pump mode selected. See FIG.'s 16 thru 19 for flow charts and pump sizing information. Refer to the FTXL Service Manual for additional information.

Set DHW/Spa boiler target temperature

When in the DHW/Spa Mode, the control will modulate to maintain the boiler outlet temperature or system supply temperature to a set point. This set point is factory-set at 104°F. If a different set point is desired, the appropriate parameter in the control must be changed. See the FTXL Service Manual for additional information.

Set maximum DHW/Spa fan speed

If the rated input of the indirect tank is less than the maximum output of the boiler, change the maximum DHW/Spa fan speed setting to limit the boiler output accordingly. Refer to the FTXL Service Manual for additional information.

TABLE I HEX Pump Speed Settings	
100061682	Speed 2 (80%)
100147366	
100147368	Speed 3 (100%)
100147369	

Secondary Auxiliary Heat Exchanger

The pump that is factory-supplied with the Secondary Heat Exchanger package is a Grundfos VersaFlo pump. It is factory-set at “Speed 3” which is the maximum speed (100%). “Speed 2” is 80% of the maximum speed and “Speed 1” is 60% of the maximum speed. The current speed selections appear in the terminal box window and the speed may be adjusted between the three possible settings.

It is recommended that a 30° - 35° Delta T be maintained across the boiler side of the Secondary HEX. Refer to Table J for HEX specific pump speed settings.

TABLE J HEX Pump Speed Settings	
100061682	Speed 2 (80%)
100147366	
100147368	Speed 3 (100%)
100147369	

Figure 15 3

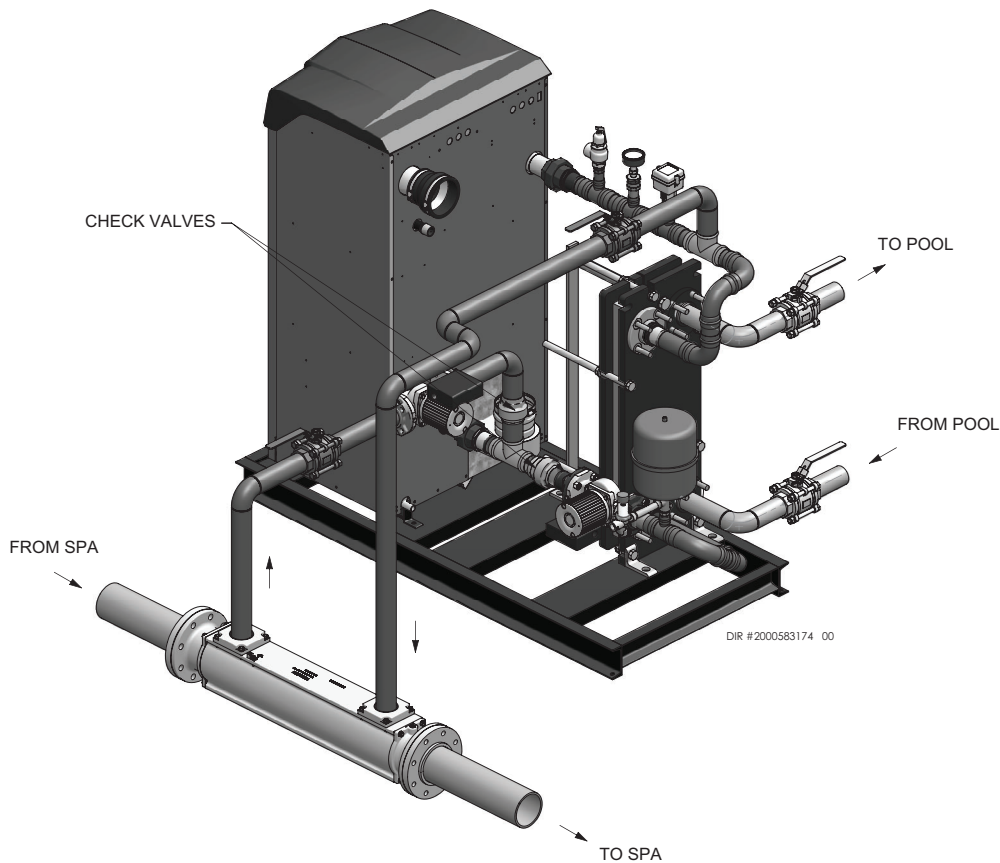

NOTICE

Please note that these illustrations are meant to show system piping concept only, the installer is responsible for all equipment and detailing required by local codes.

NOTICE

Reduce water piping only at Secondary HEX tapping. Piping to and from the HEX should be sized so that it is identical to AQUAS piping.

Figure 16 Shell and Tube Flow - 100061682

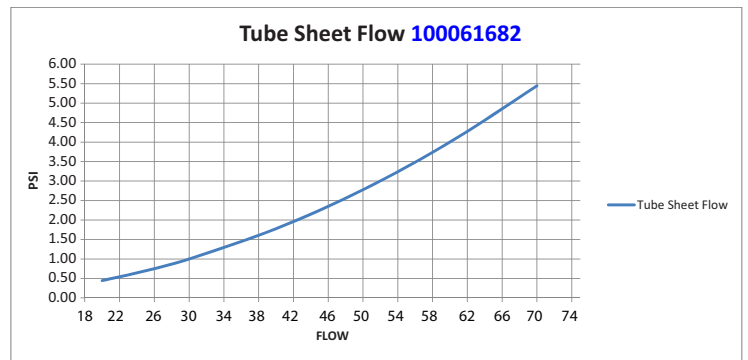
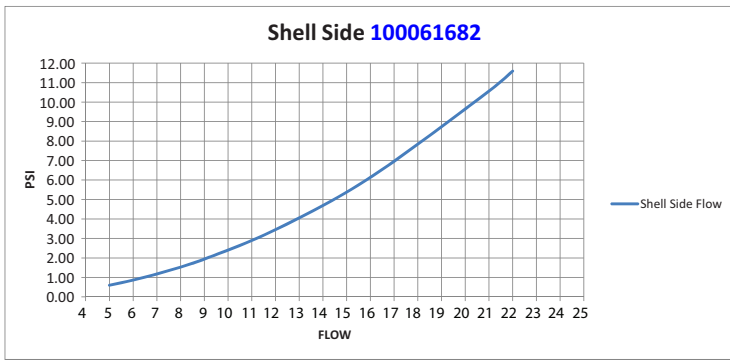

Figure 17 Shell and Tube Flow - 100147366

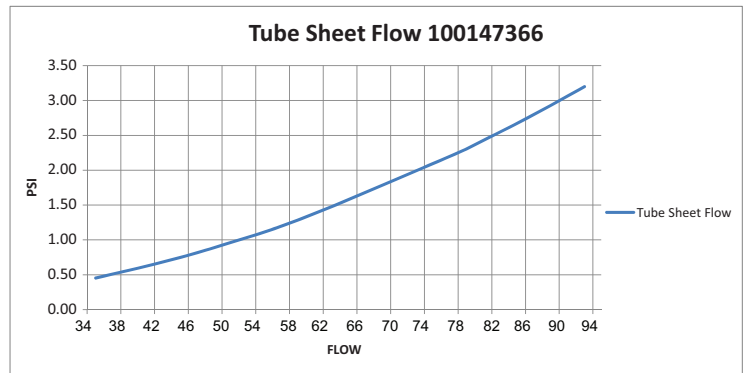
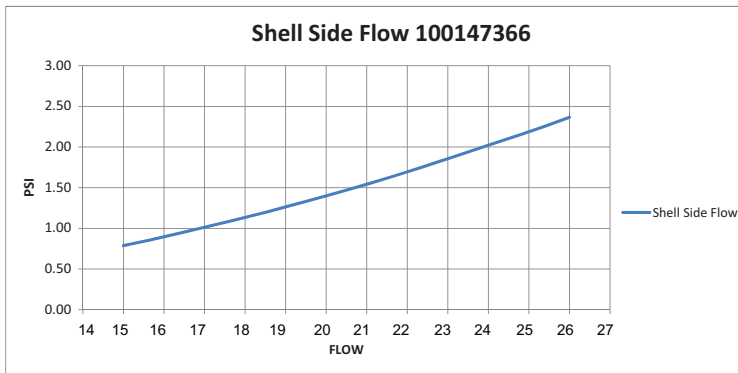

Figure 18 Shell and Tube Flow - 100147368

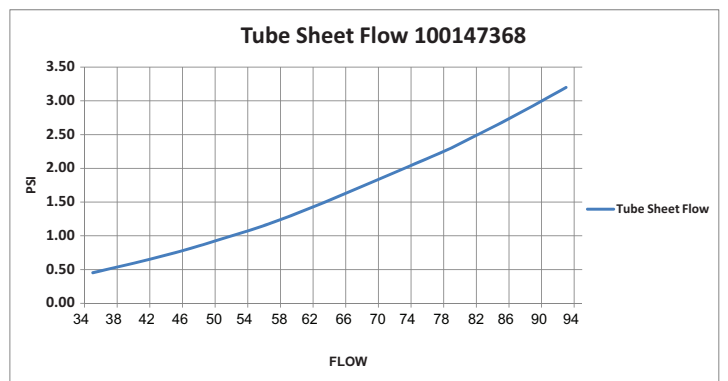
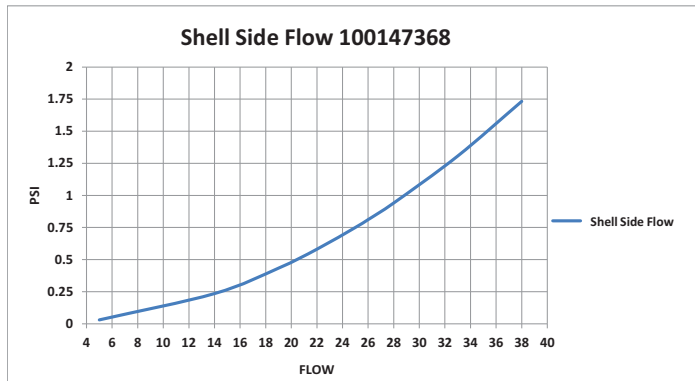
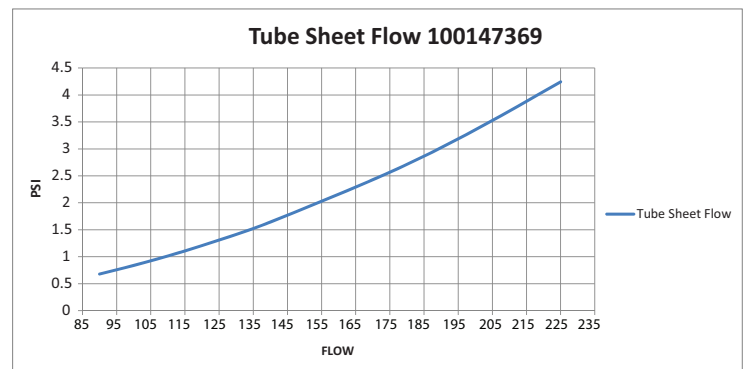
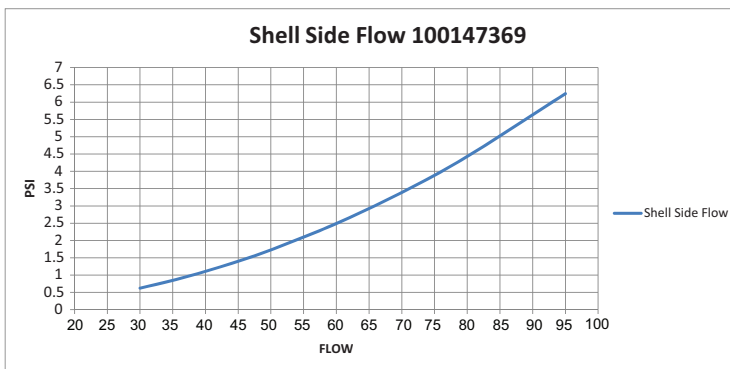

Figure 19 Shell and Tube Flow - 100147369



Revision Notes: Revision A (PCP# 3000038139 / CN# 5000026401) initial release.