

# INDOOR/OUTDOOR AQUAS™ POOL PACKAGE INSTALLATION INSTRUCTIONS

## FOR MODELS: APO 750 - 6000 SERIES 200 (NAT) - 201 (LP)

### AQUAS Pool Package

The indoor/outdoor AQUAS pool package system is a high efficiency commercial condensing boiler package system pre-piped to an indirect heat exchanger from the factory. This pool heater is a low temperature operating system designed to take advantage of the stainless steel heat exchanger and condensing operating temperatures to ensure the highest efficiency possible. The AQUAS is designed around a predetermined flow, set by the manufacturer, between the boiler and the indirect heat exchanger. The AQUAS operates off the pool system pump itself which will continually supply water to the indirect heat exchanger. This means there is no need to purchase a dedicated circulator to deliver water to this package system.

### Installation Instructions

To achieve the optimum operating efficiency of your AQUAS it is recommended that you keep the pool water flow of each appliance within plus or minus five gallons per minute of the recommended flow as stated in Table A. Low flow through the indirect heat exchanger will result in elevated temperatures supplied to the pool.

TABLE A			
MODEL	RECOMMENDED SYSTEM WATER FLOW (GPM)	CONNECTION SIZE	PRESSURE LOSS (PSI)
750	96	3"	< 5
1000	128	3"	< 5
1250	167	3"	< 5
1500	192	3"	< 5
1750	215	3"	< 5
2000	225	3"	< 5
2500	320	4"	< 5
3000	384	4"	< 5
3500	448	6"	< 5
4000	512	6"	< 5
5000	640	6"	< 5
6000	768	6"	< 5

**RECOMMENDED CLEARANCES:**  
BOILER - SEE CREST I & O MANUAL

**NOTE:** Model 1000 shown for illustration purposes only.

### Piping

Pool / spa connections to the indirect heat exchanger are SCH 80 CPVC glue fittings. The connections from the field loop to the heat exchanger may be done in CPVC or PVC pipe as follows:

- Use cement on the connections that are rated for CPVC.
- To make the connection, apply glue to both the CPVC flange and the section of pipe.
- Insert the pipe into the flange until it reaches the bottom of the flange.
- Turn the pipe a half turn in the socket to ensure that a proper seal is made.

Pool water is designed to flow from bottom to top standing in front of the boiler.

### Throttling Valve

A  $\Delta T$  of 15°F - 20°F across the indirect heat exchanger is recommended. Throttling valves should be used to set the flow through the indirect heat exchanger on the pool loop. (Standard gate valves are acceptable.)

**Figure 1 Component Location**

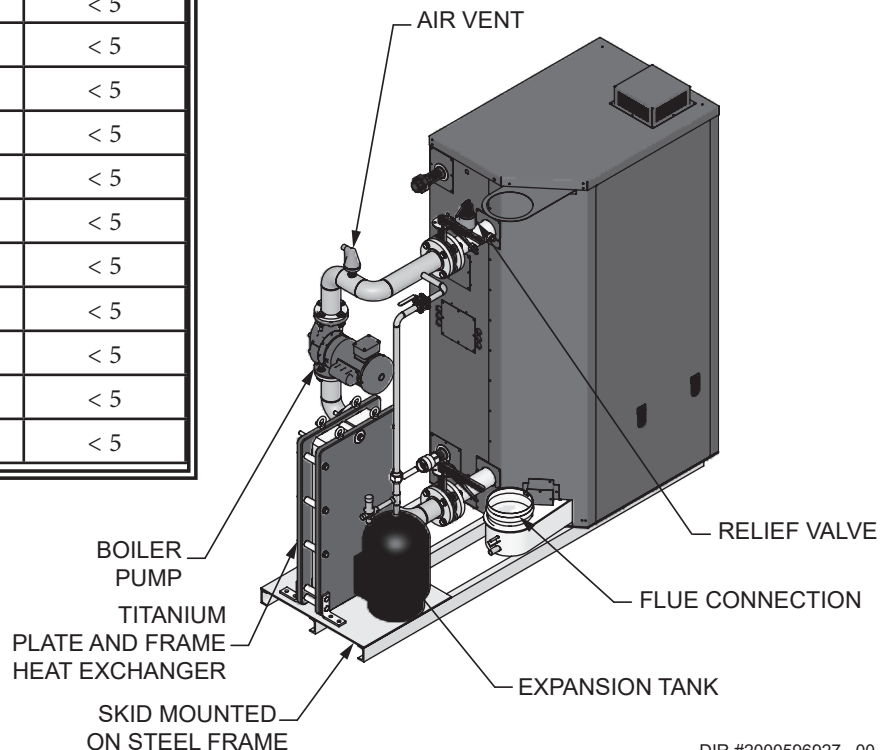

**The system can be installed in either a Full Flow or Diverted Flow orientation:**

**Full Flow** (reference FIG. 8)

If the total system flow of the swimming pool or spa system is within five gallons per minute of the recommended system water flow as shown in Table A on page 1, this type of system is recommended.

**Diverted Flow** (reference FIG.'s 9 & 10)

Criteria for installing a diverted flow system is as follows:

- If the total system flow is greater than the amount required by the indirect heat exchanger.
- Installations with temperatures in excess of 95°F. This is necessary so the pool high limit will not trip. No water should enter the pool / spa in excess of 115°F. If the heat exchanger pool outlet is in excess of 115°F the water must be tempered down.
- Multiple unit installation.

**Example:** Total system flow is 500 gallons per minute (GPM). If two 1,500,000 Btu/hr units were installed, each of the pool packages would require 192 GPM for a total of 384 GPM of the pool water being diverted through the indirect heat exchangers, while the other 116 GPM would be diverted back to the pool.

**Safety High Limit Requirements**

Ensure that the 115°F safety high limit control is installed in the filter system piping. Install the high limit a minimum of three feet downstream from the point where the heated water from the indirect heat exchanger is added to the filtration system (see FIG.'s 8 - 10). If the water leaving the heat exchanger is in excess of 115°F a bypass must be installed to temper the water below 115°F before re-entering the pool/spa.

The high limit will be mounted in a 3/8" NPT tapped fitting installed in the filtration system piping or it may be installed directly into a tapped opening in the PVC filter system piping. Turn off the filter system pump when installing the high limit in the filtration system piping. Tapped openings can be added to the PVC pipe by first drilling 9/16" pilot holes in the PVC pipe at least three feet downstream of the point where the heated water from the indirect heat exchanger is added to the filter piping. The drilled pilot holes can now be carefully threaded with a 3/8" NPT tap. After the pipe threads have been cut into the PVC pipe wall the high limit and bulbwell can be inserted into the tapped openings.

Apply a small amount of a high quality RTV silicone sealant to the threads to prevent leaks and install the high limit and bulbwell into the threaded opening in the pipe. Install the high limit control and bulbwell and tighten to seal. Do not over-tighten either part into the threaded opening in the PVC pipe. Over tightening can damage the parts and/or strip the threads cut into the plastic pipe. Wire the 115°F high limit into the pool heater control circuit as shown in FIG. 2 on page 3. If additional wire length is needed, use 18 gauge wire for distances up to 30 feet. For longer distances, size the wire per Table B.

<b>TABLE B</b>	
<b>Remote Wire Connection</b>	
<b>WIRE GAUGE</b>	<b>MAXIMUM ALLOWABLE LENGTH</b>
12 GA	100 ft.
14 GA	75 ft.
16 GA	50 ft.
18 GA	30 ft.

Figure 2 Low Voltage Connections

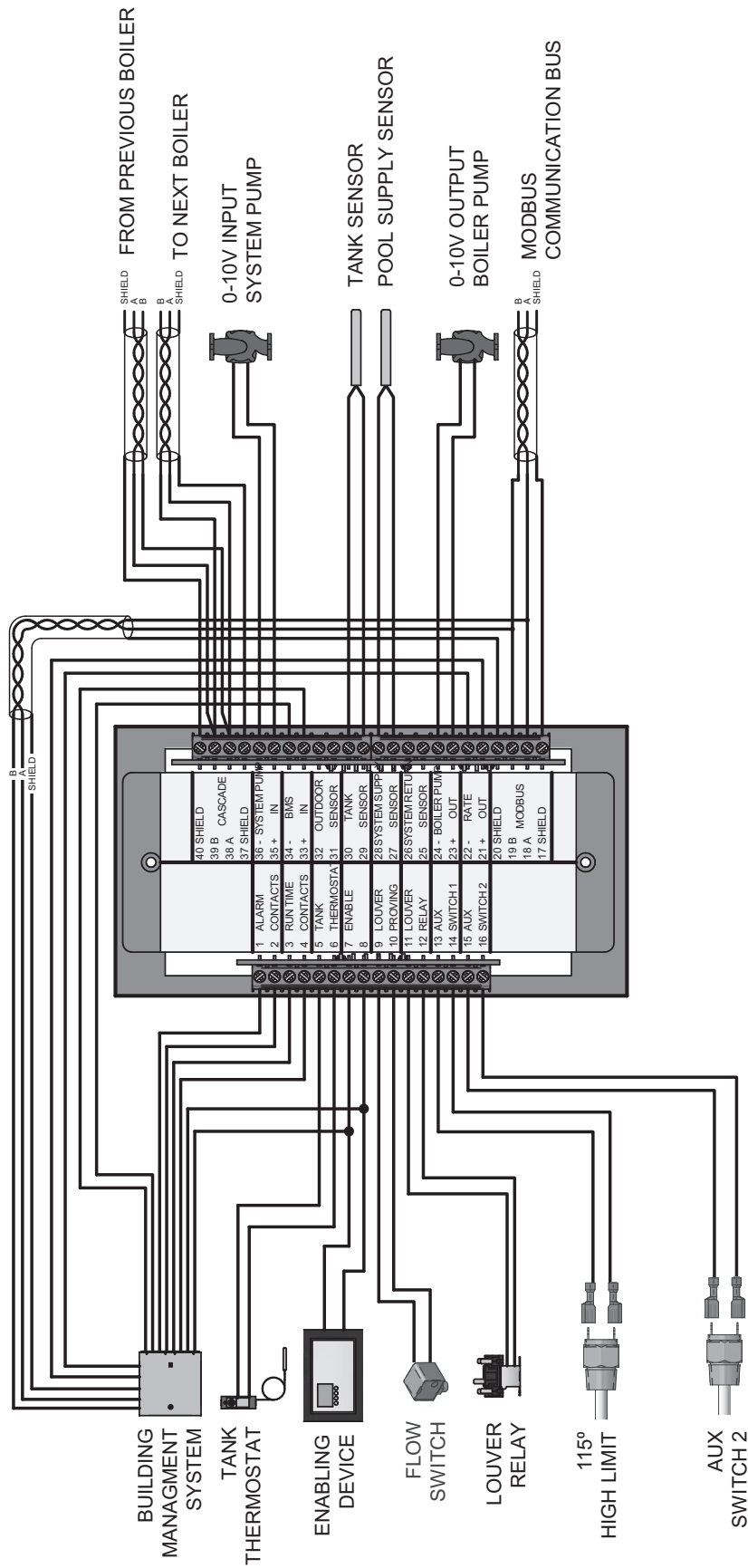

DIR #2000574261

## Line Voltage Connections

The AQUAS pool package has a dual point line voltage connection. One line voltage is wired directly to the boiler, and another line voltage is wired directly to the pump (FIG. 3). See Table C for correct line voltage / amperage for each piece of equipment. Provide and install a fused disconnect or service switch (20 amp recommended) as required by local codes.

TABLE C Total Amps				
Model	Boiler Voltage	Boiler Amps (FLA)	Pump Voltage	Pump Amps (FLA)
750	120V/1	5	120V/1	8.6
1000	120V/1	6	120V/1	8.6
1250	120V/1	7	120V/1	8.6
1500	120V/1	10	120V/1	8.5
1750	120V/1	10	120V/1	8.5
2000	120V/1	13	120V/1	8.5
2500	208V/3	4.5	208V/3	<10
3000	208V/3	6.5	208V/3	<10
3500	208V/3	6.5	208V/3	<10
4000	480V/3	6	480V/3	<10
5000	480V/3	5	480V/3	<10
6000	480V/3	7	480V/3	<10

Figure 3 Line Voltage Field Wiring Connections - 120V Model Shown

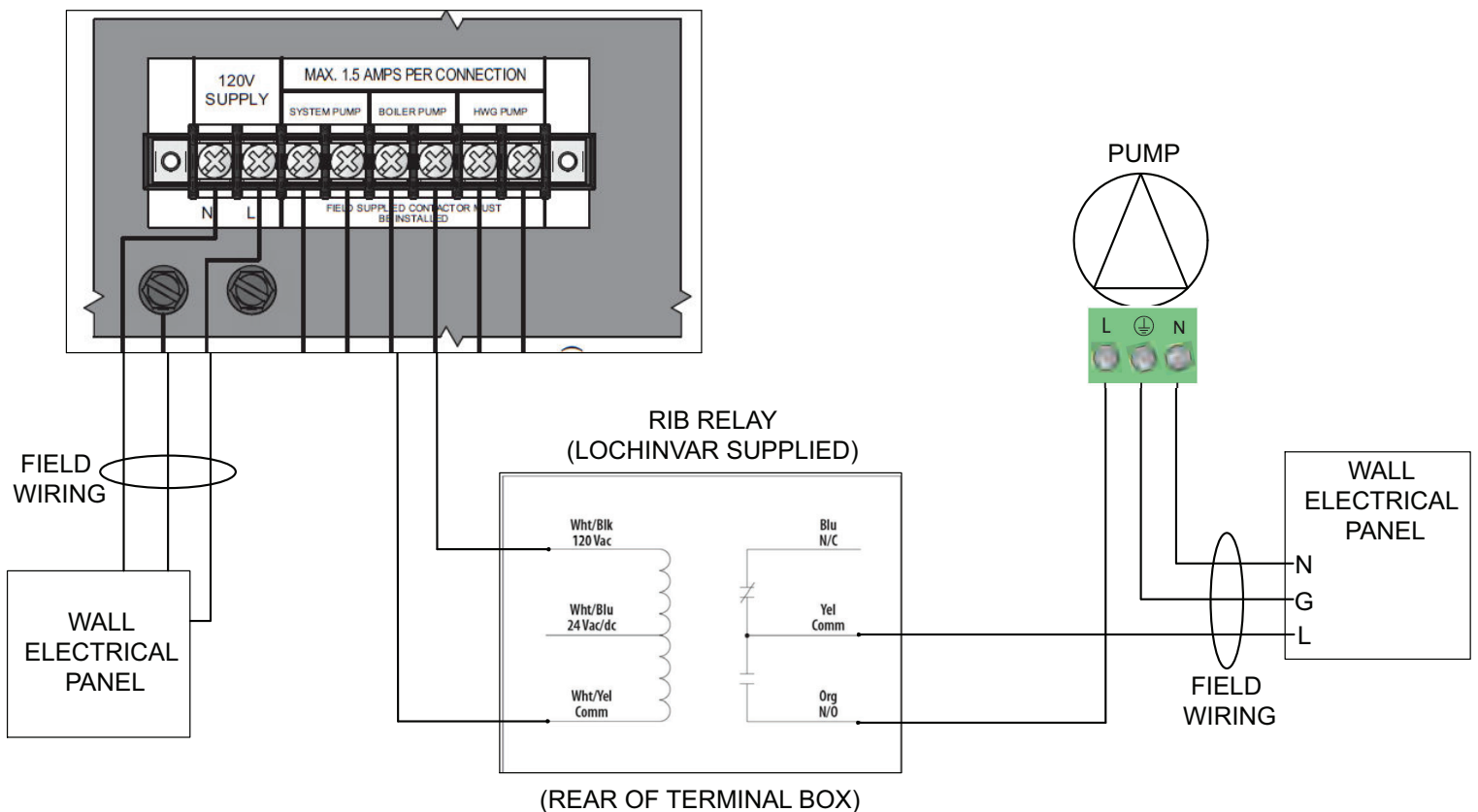

DIR #2000574259

# Indirect Heat Exchanger

## Installation Instructions

Heat exchangers should be installed downstream of the pumping and filtration equipment (FIG. 4).

**Figure 4 Pumping and Filtration Equipment**

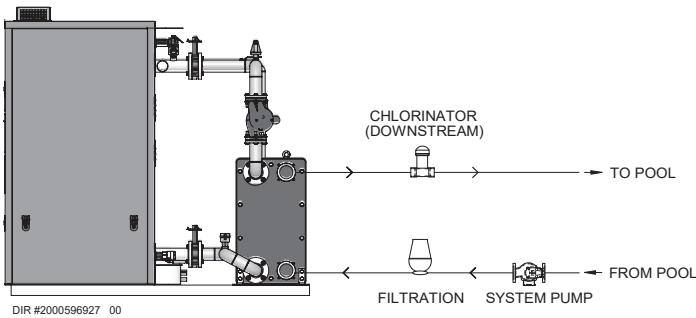

### Pool Water Chemistry

It is essential that the instructions in this section and the Ryznar Stability Index and/or Calcium Stability Index are followed to prevent corrosion / erosion of the indirect heat exchanger:

- Always keep pH within correct levels. The ideal pool pH should be kept within 7.4 to 7.6.
- Under no circumstances should the pH fall below 7.2 or rise above 7.8 (see FIG. 5). Check on a day-to-day basis. Alter pool conditions as necessary.
- Ensure that chlorine levels are within the range recommended by the chemical manufacturer and are in accordance with the type of pool, for example; private, hotel, school or municipal.
- If a bypass is fitted to the indirect heat exchanger circuit, it is essential that any or all of the valves are correctly positioned to allow the recommended pool water flow to pass through the heat exchanger.
- The system filter unit should be checked regularly, especially sand filters (to detect sand and diatomaceous earth). Sand filters, if working incorrectly, can allow sand to pass around the pool circuit causing erosion of the pipe work and heat exchanger. Keep the pool free from debris such as leaves, grass cuttings, etc. This foreign matter can cause decay and increase pH.
- It is essential that the correct chlorine dosage is added to the pool. To allow proper dispersion of the dose in the pool water, distribute the chemicals to various areas of the pool. Do not dose in one area only, as this will create highly acidic areas which can cause corrosion / erosion of the pool equipment.

**Figure 5 pH Scale**

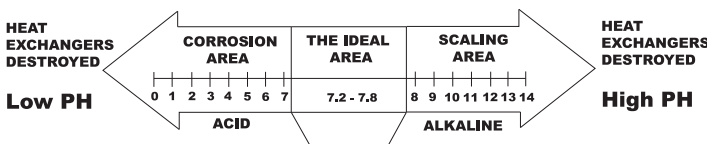

- Chlorinators must feed downstream of the pool heater and have an anti-siphoning device to prevent chemical backup in the heater when the pump is shut off.

### CAUTION

High chemical concentrations from improperly adjusted feeders, chlorinators, or salt levels above 5000 ppm can cause rapid corrosion to the heat exchanger.

We recommend a periodic analysis be performed to maintain and ensure proper operation of your pool heater (see Table D).

TABLE D RECOMMENDED POOL CHEMISTRY LEVELS	
Test	Recommended Level
Bromine	2.0 - 4.0 ppm
Calcium Hardness	200 - 400 ppm
Cyanuric Acid	50 - 75 ppm
Free Chlorine	1.0 - 3.0 ppm
pH	7.4 - 7.6
Salt (residential pool)	3000 ppm
Salt (commercial pool)	5000 ppm
TDS	300 - 1500 ppm
Total Alkalinity	80 - 120 ppm

### Filling the System

The boiler is filled through the pressure reducing auto-fill valve. The operating pressure of this system is 15 psi between the heater and the indirect heat exchanger. There are no adjustments necessary for the fill valve cartridge (factory set). The expansion tank is set at 20 psi. It is necessary to check the pressure of the expansion tank when annual maintenance is performed. The boiler system operates off a city or potable water system which feeds a closed loop system. A hard line is piped from the potable water supply to the pressure reducing valve. This water is to remain ON at all times when the system is in operation.

### Pressure Reducing Valve

The valve is equipped with a fast-fill feature that can be used to override normal operation when filling and purging the system. To activate fast-fill, push and hold down the fast-fill knob on top of the cartridge as shown in FIG.6.

**Figure 6 Pressure Reducing Auto-Fill Valve**

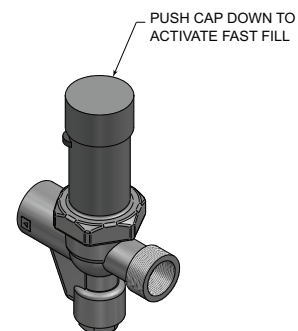

## Makeup Water Assembly

### NOTICE

In the following steps, a backup wrench is necessary to properly attach the makeup water assembly.

1. Connect the 1/2" nipple to the reducing tee and connect the pressure reducing valve to the 1/2" nipple.

**Figure 7** Connecting the Makeup Water Assembly

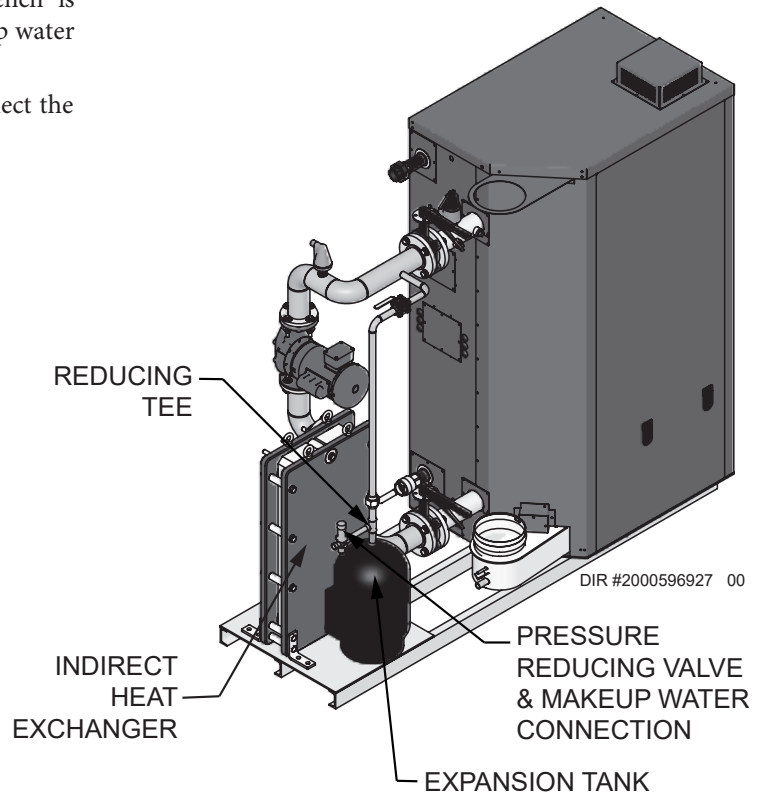

**Figure 8** Full Flow

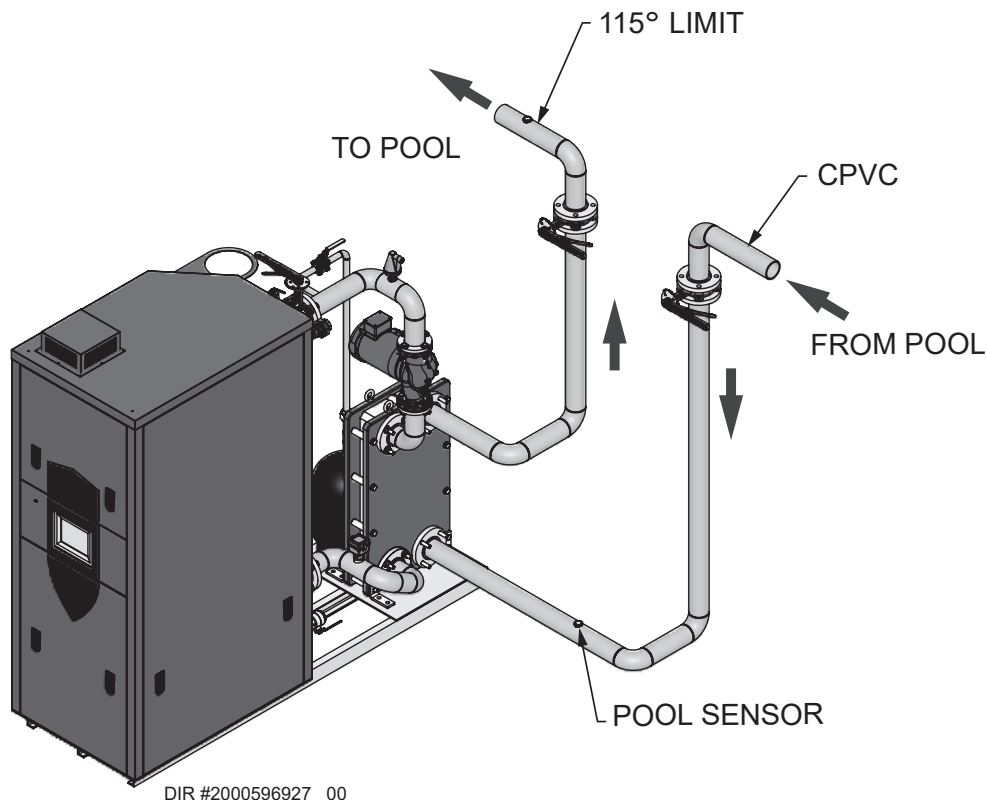

### NOTICE

Please note that these illustrations are meant to show system piping concept only, the installer is responsible for all equipment and detailing required by local codes.

### NOTICE

System flow should always remain higher than the required flow for the boiler(s) when the boiler(s) is in operation to prevent short cycling and high limit issues.

**Figure 9 Bypass (if flow is greater than required by heat exchanger)**

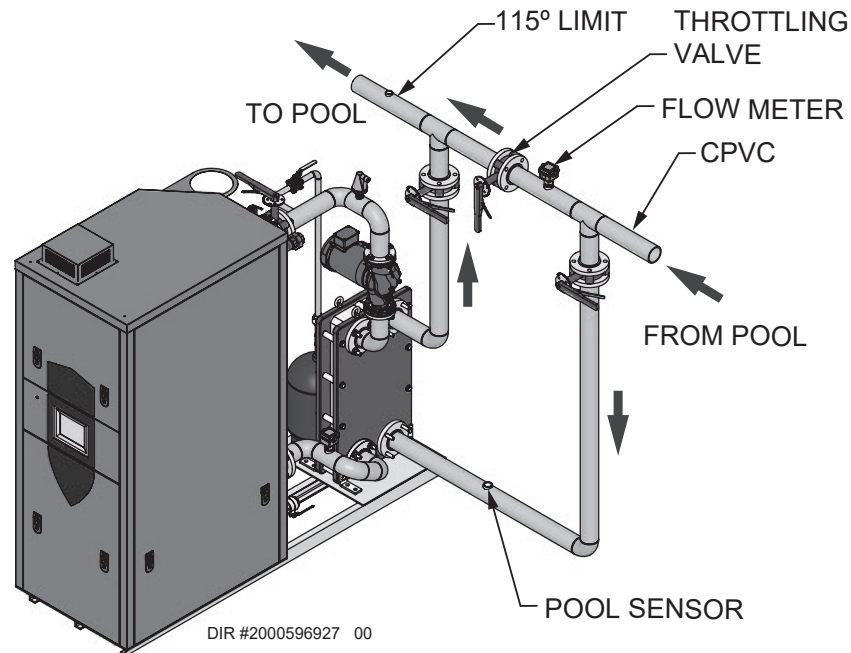

**NOTICE**

Adjust valves to provide suggested flow per Table A on page 1.

**Figure 10 Bypass Multiple Units (if flow is greater than required by heat exchanger)**

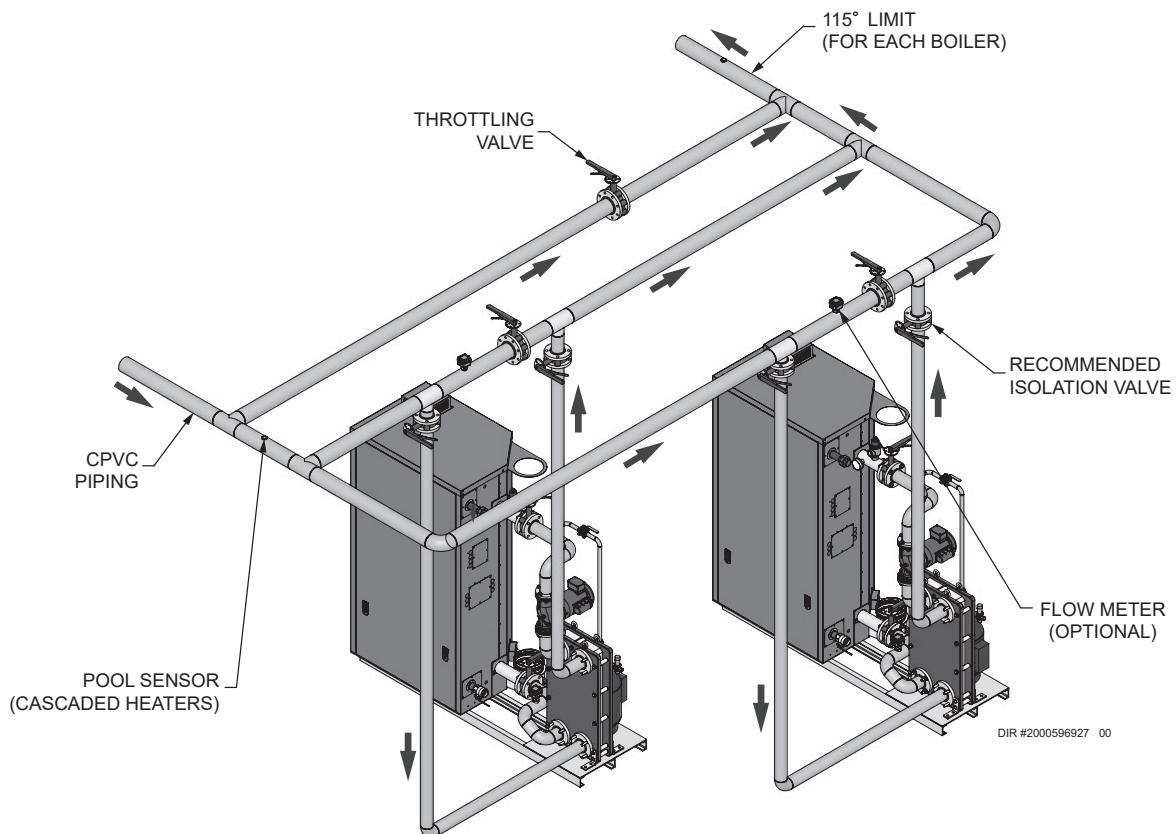

**NOTICE**

Please note that these illustrations are meant to show system piping concept only, the installer is responsible for all equipment and detailing required by local codes.

**NOTICE**

System flow should always remain higher than the required flow for the boiler(s) when the boiler(s) is in operation to prevent short cycling and high limit issues.

## DHW / Spa Tappings (Optional)

### Pump sizing

The AQUAS has a single pump for the pool heat exchanger along with an additional pump for a DHW/Spa loop.

#### Example:

Boiler: APO2000

A  $\Delta T$  of 40° requires a flow through the heat exchanger of 96 GPM. The heat exchanger head loss is 1.3 ft. of head.

### Heater Pump

The pump that is factory supplied with the optional Auxiliary Heat Exchanger package is a Grundfos VersaFlo pump. It is factory-set at “Speed 3” which is the maximum speed (100%). “Speed 2” is 80% of the maximum speed and “Speed 1” is 60% of the maximum speed. The current speed selections appear in the terminal box window and the speed may be adjusted between the three possible settings.

It is recommended that a 30° - 35° Delta T be maintained across the boiler side of the Auxiliary HEX. Refer to Table E for HEX specific pump speed settings.

TABLE E		
Auxiliary Heat Exchanger	Part Number	Optimal Pump Speed Settings
200,000 BTU	100061682	Speed 2 (80%)
400,000 BTU	100147366	
650,000 BTU	100147368	Speed 3 (100%)
1,000,000 BTU	100147369	

Figure 11 Piping Connections for DHW / Spa

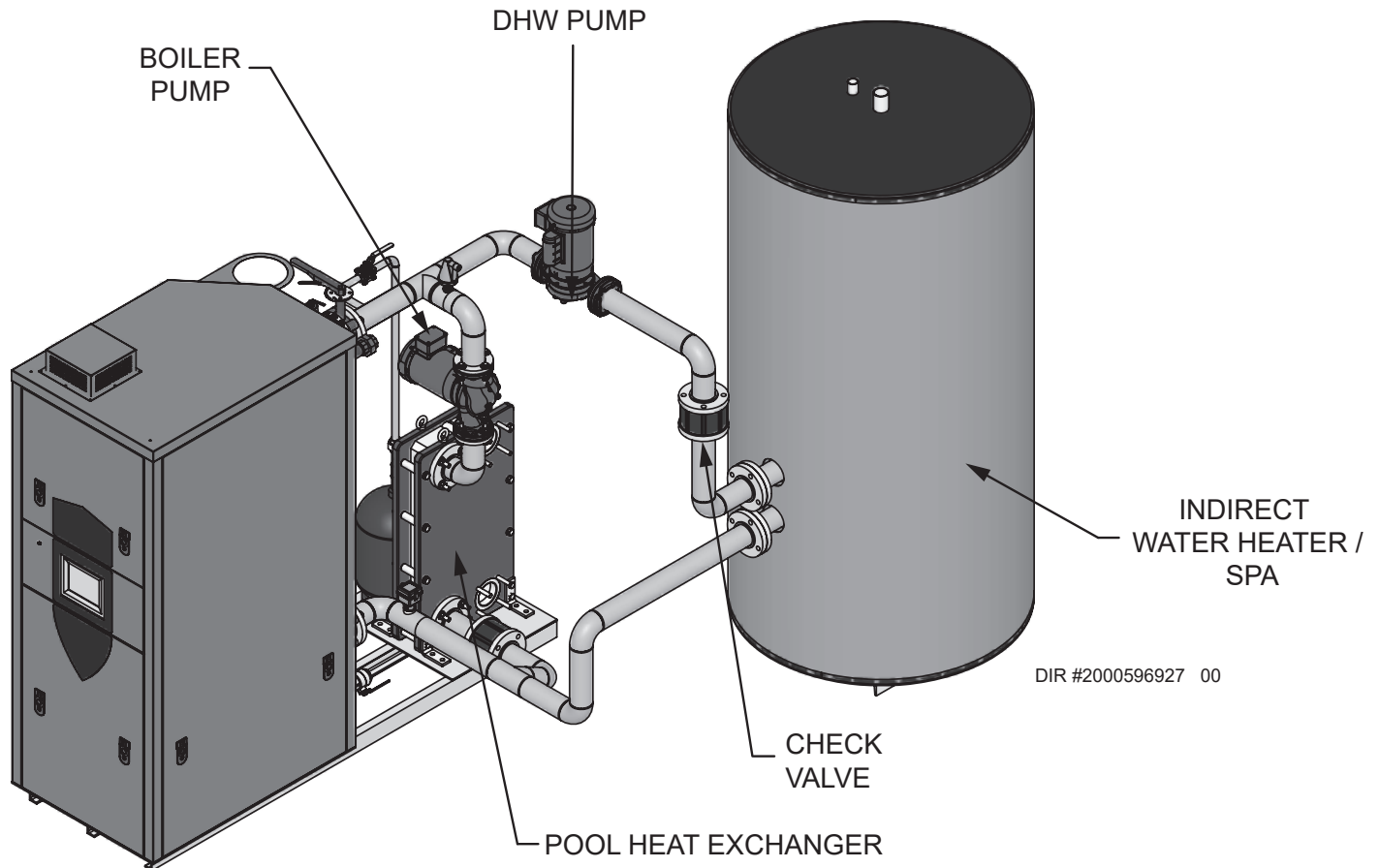

The Home Screen displays the available basic system information divided into the following sections: Status, Demand, Modulation, Sensors, and Navigation.

Figure 12 Home Screen

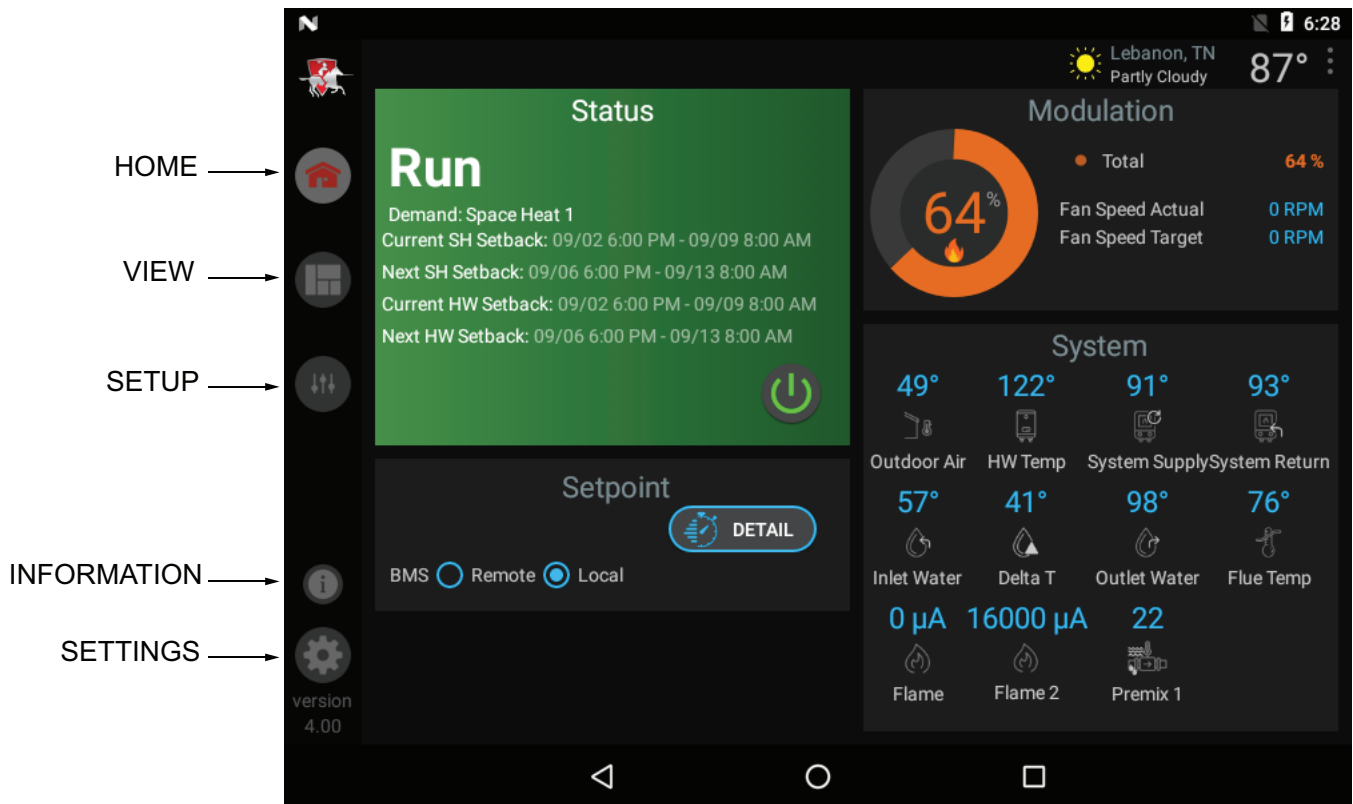

## AQUAS Pool Setup

When the ON/OFF switch is turned to the ON position, the first screen visible on the LCD display will be the Home Screen. This screen displays the current status of the Crest boiler.

- The **Status** Section is located on the top left of the screen and displays how the unit is currently running (i.e. Off, Stand-by, Blocking, and Lockout) including: current driving demand, the next Hot Water Setback scheduled, the reason for any blocking or lockout, and a power button.
- The **Demand** Section is located on the bottom left of the screen and displays information about the targets and limits of the current demand being serviced.
- The **Modulation** Section is located on the top right of the screen and displays the target modulation of the unit. This section also includes target and actual fan speeds.
- The **Sensor** Section is located on the bottom right of the screen and displays both factory installed and field installed sensor including: Outdoor Air, Hot Water Temperature, System Supply, System Return, Inlet Water, Delta T, Outlet Water, Flue Temperature, and Flame Current.

- The **Navigation** Section is located down the left side of the screen. There are five (5) sections located below the Lochinvar icon: Home, View, Setup, Information (About), and Settings. The Home Section is the screen shown above. The View Section provides more detailed information including subsections for: History, Cascade, Graphing, and a complete list of current Sensor Values. The Setup Section has several screens to aid in setting up the appliance. The Setup Section includes screens for adjusting: Set Points, Pump Settings, Cascade, BMS, Ramp Delay, and Night Setback. The Information Section provides information about the hardware and software including the current software version of the interface, the version of the boiler control, and the CON•X•US device serial number. The Setting Section enables several interface setup features including: Time Setup, Temperature Unit Select, Loch'n Link, System Update, and WiFi Setup.

## Cascade

When multiple boilers are installed, they can be wired together in a cascade sequence. A maximum of eight boilers can be controlled from a single control. In this application one boiler would be designated as the Leader control and all others would be designated as Member controls.

Once the Leader boiler receives a call for heat from the Enable input or 0 - 10 VDC input, ModBus, or BACnet, the control will determine what the set point will be.

If the water temperature at the controlling sensor is less than the set point + the turn-off offset - the off-on differential, the control will initiate a call for heat on the Cascade (see the Crest Service Manual for an explanation of the offset and differential). The Leader will energize the lead boiler on the Cascade. For a new startup, this will be the Leader boiler.

### Efficiency optimization

Efficiency optimization is chosen when the application is such that overall heating efficiency is most important. The Cascade will fire the boilers in a way that is the most efficient. This allows more boilers to fire at one time, at a lower rate, thus more efficient. This Cascade is **NOT** allowed in a common vent application.

### Lead/Lag

The Lead/Lag method is chosen when the application requires firing as few boilers at a time as possible. This method will not bring on another boiler until the current number of boilers cannot meet the demand. This Cascade is also *required* when cascading boilers in a common vent application.

The parameters for both types of Cascade are adjustable. Reference the Crest Service Manual for a more detailed description of these adjustments.

### Sequence of the cascade

To equalize the run time of all boilers on the Cascade, the firing sequence will automatically be changed at set intervals.

For the first 24 hours after initializing the Cascade, the sequence will be changed every hour. After that the sequence will be changed once every 24 hours.

## Cascade Parameters Screen:

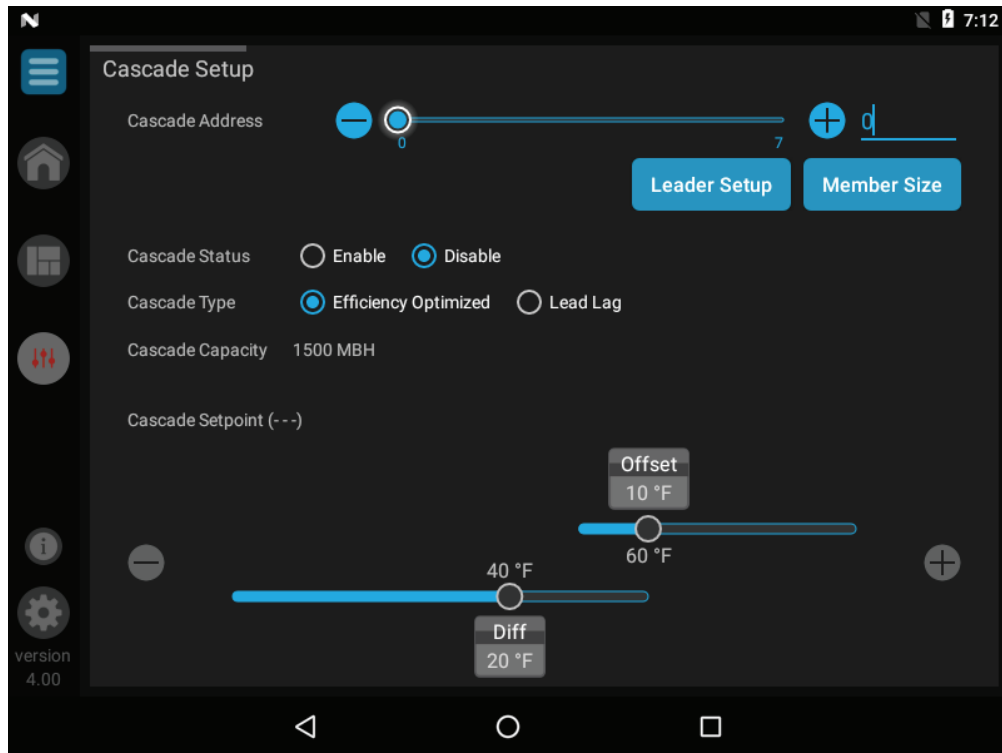

### Cascade Address

The boiler designated as the Leader needs to be programmed with address 0. All the Member boilers require addresses from 1 to 7, and the addresses must be different for each Member. The addresses can be in any order, regardless of the order in which the units are wired together. The outdoor air (if used) and system supply sensor must be connected to the Leader boiler.

### Cascade Status

The boiler is part of a group of units sequenced together. The designated Leader unit determines the total output needed from the group based on the set point and controlling sensor reading. It assigns portions of the output to itself (Leader) and the Member units. When Cascade is active, each boiler in the group requires a unique address.

### Cascade Set point Offset

This parameter determines how much the temperature can go above set point before the lead boiler will turn off.

### Cascade Set point Differential

This parameter determines how much the temperature must go below the turn-off temperature (Set point + Offset) before the lead boiler turns on.

## Configuration of the cascade

**Note:** For more detailed instructions, please refer to the Crest Service Manual.

When installed in a Cascade system, the individual controls must be programmed for Cascade operation. Access the Cascade Setup options as follows:

1. Press the SETUP button on the top of the display screen.
2. Enter the installer password.

3. Scroll through the scrolling menu feature to access the Cascade option.
4. Press the CASCADE button.
5. Once all the updates are complete, press the SEND UPDATE button at the top of the screen to save changes.

**Note:** The SEND UPDATE button must be pressed to ensure proper programming of the controls. Failure to press the SEND UPDATE button will require all changes to be reprogrammed.

## Sequence of operation

<b>1.</b>	Upon a call for heat, the control turns on the appropriate pumps (system and boiler pumps for a space heating call, HW pump for a hot water generator call).
<b>2.</b>	The control confirms that the low water cutoff contacts are closed and energizes the louvers (optional) and damper (optional) relays.
<b>3.</b>	The control confirms that the proof of closure switch (Model APO6000 only), gas pressure switch, blocked drain switch, limits, louver proving switch (optional) and damper proving switch (optional) contacts close. The proof of closure valve (APO6000 only) opens and the Pre-Purge cycle begins.
<b>4.</b>	The control confirms the blower is up to the desired speed, and the air pressure switch is closed.
<b>5.</b>	Once the Pre-Purge cycle is complete, the control lowers the blower speed, initiates sparking of the ignition electrode, and opens gas valve 1.
<b>6.</b>	After a short wait, the control stops sparking and checks for the presence of flame current through the flame sense electrode.
<b>7.</b>	If the control does not detect flame current: Models APO750-2000 - The control will repeat the ignition cycle after the required post purge and pre-purge cycles. Models APO2500-6000 - Loss of flame will result in safety shutdown and lockout, requiring manual reset.
<b>8.</b>	If the control detects flame current, the control will hold the blower speed constant for a few seconds to allow the flame to stabilize, then begin modulating the firing rate in order to maintain the controlling sensor to the desired set point temperature.
<b>9.</b>	If the current call for heat is for space heating and a HW call for heat becomes active, the control will turn on the HW pump relay output, then turn off the boiler pump. It will then modulate the blower speed in order to maintain the outlet temperature to the desired HW outlet set point temperature.
<b>10.</b>	If the boiler is unable to maintain the desired set point using gas valve 1, control will transition to the larger gas valve 2. The blower will modulate to a fixed speed and the air metering valve will start to open. As it opens, gas valve 2 will be turned on and gas valve 1 will be turned off. If the flame should be lost at any time during this process, the control will immediately try to reignite the burner. Once the air metering valve is fully open and the flame is confirmed to be present, the control will hold the fan speed constant for a few seconds in order to allow the flame to stabilize. The fan speed will then modulate as needed to maintain the set point. If the flame is not present when the air metering valve is fully open, the boiler will go through a complete shutdown and restart of the burner. If the heat load should decrease sufficiently, a similar process is used to transition from gas valve 2 to gas valve 1.
<b>11.</b>	Once both the space heating and HW calls for heat are satisfied, the control will turn off the gas valve and begin the Post-Purge cycle. Any pumps that are running will begin their respective Pump Delay cycles.
<b>12.</b>	At the end of the Post-Purge cycle, the louver relay contacts will de-energize.
<b>13.</b>	The control verifies that the blowers stop running and the blower proving switches open.
<b>14.</b>	At the end of the Pump Delay cycle(s), the pump(s) will be turned off.

## Pool Heat Exchanger Maintenance

Take care to ensure that fluids are contained during performance of inspection, maintenance, testing, adjusting, and repair of the product. Be prepared to collect the fluid in suitable containers before opening any compartments or disassembling any components that contain fluids.

Dispose of all fluids in accordance with local regulations and mandates.

### Disassembly procedure

1. Drain the heat exchanger (HEX) from fluids into a suitable container for storage or disposal.
2. Disconnect the heat exchanger from the appliance by removing any hoses, piping, or mounting bolts. Remove the heat exchanger and place on a clean surface.
3. Unscrew bolts on the short side and mount alignment spacers or extensions to keep the plate pack in position when decompressing the front frame.
4. Slowly unbolt in a regular sequence until all bolts are unscrewed.
5. Remove the front frame plate from the top of the heat exchanger plate pack and place it on a clean surface. Check for signs of damage.
6. Remove spacers.
7. Remove all of the individual heat exchanger plates. **NOTE:** A good procedure is to place the plate on a clean surface with each plate turned over, and then place the next plate on top of the last one. This keeps the plate pack in order.

### Instructions for cleaning

Clean the plates with a coarse nylon brush or nylon pad. Do not use a dirty pad, steel wool, or a wire brush which may scratch the titanium plates of the aluminum frames. Any iron scratches in the titanium plates can lead to corrosion of the plates. See Table F for recommended cleaning solutions.

**Table F** Recommended cleaning solutions

Liquid	Description
AlfaCaus	A strong alkaline liquid for removing paint, fat, oil, and biological deposits.
AlfaPhos	An acid cleaning liquid for removing metallic oxides, rust, lime, and other inorganic scale. Contains repassivation inhibitor.
AlfaNetura	A strong alkaline liquid for neutralization of AlfaPhos before drainage.
Alfa P-Neutra	For neutralization of Alfa P-Scale.
Alfa P-Scale	An acidic powder cleaner for the removal of primary carbonate scale and other inorganic scale.
AlfaDescalent	A non-hazardous acidic cleaning agent for the removal of inorganic scale.
AlfaDegreaser	A non-hazardous cleaning agent for the removal of oil, grease, or wax deposits. Also prevents foaming when using Alpacon Descaler.
AlfaAdd	AlfaAdd is a neutral cleaning strengthener designed to be used with AlfaPhos, AlfaCaus, and Alfa P-Scale. 0.5-1 vol% is added to the total diluted cleaning solution to provide better cleaning results on oily and fatty surfaces and where biological growth occurs. AlfaAdd also reduces any foaming.

### Reassembly procedure

1. Place the bottom frame on a flat surface.
2. Mount the alignment spacers on the short side of the frame.
3. Place channel plates in the same order that they were removed. **NOTE:** Chevron angles will alternate. For example, if the first plate chevron points left, then the second plate chevron will point right.
4. Continue assembling the cleaned plates onto the rear frame with alternating chevron patterns. **NOTE:** Ensure that the gasket tabs are locked into position as each plate is installed. Ensure that the gasket tabs alternate to create a honeycomb pattern throughout the plate pack (FIG. 13).
5. Place all spacers in their respective locations.
6. Place the front frame over the alignment spacer and slide it down onto the plate pack. **NOTE:** The top hat spacers will be installed later.
7. Install washers onto four (4) extended length bolts. Install the four (4) extended length bolts into the four (4) corners of the front frame plate screwing them into the spacers.
8. Use the four (4) extended length bolts to compress the plate pack until the standard length bolts can be hand started into the spacers for the remaining bolt holes in the front frame plate.
9. Hand start all remaining bolts before loosening the four (4) extended length bolts and installing the four (4) standard length bolts in their relative locations. **NOTE:** Use caution when loosening the extended length bolts as the plate packs will be compressed.
10. Screw all bolts into the spacers with an alternating pattern about 5 to 10 mm per time. Continue to screw bolts until the front frame is tight against the top of the spacers.
11. Remove the alignment spacer or spacer extensions.
12. Install the top hat spacers and bolts through the front frame and into the spacers on the short side.

Figure 13 Plate pack pattern

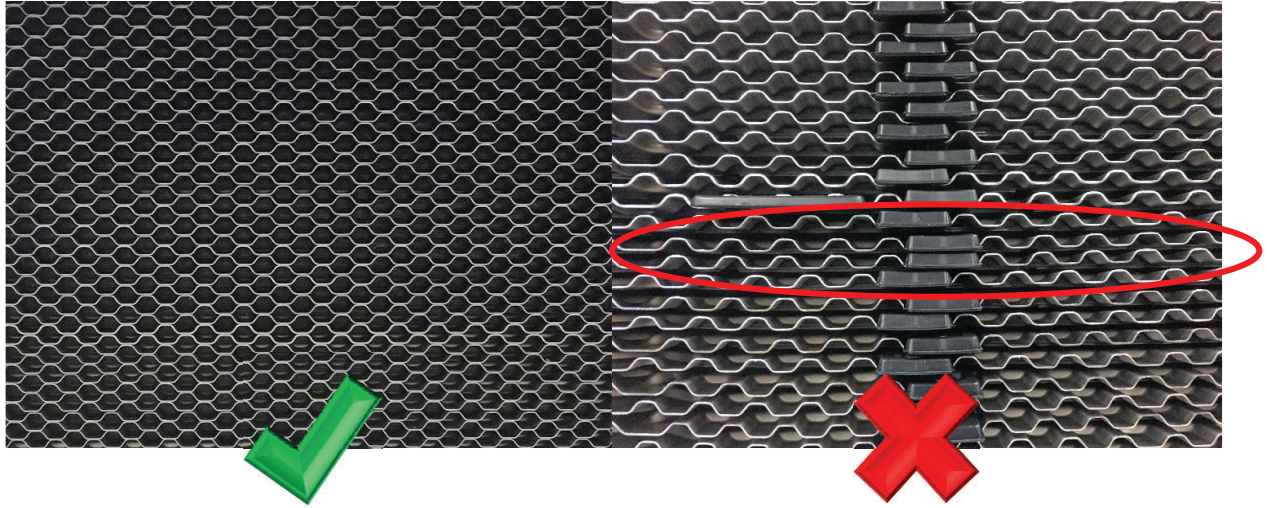

## Notes

**Revision Notes:** *Revision A (PCP #3000033291 / CN #500022171) initial release.*

*Revision B (PCP #3000042689 / CN #500030481) reflects general design updates.*