

MODBUS AND BACNET COMMUNICATION INSTRUCTIONS

Models:

**Knight 81 - 286, Knight XL 400 - 801,
Armor 151 - 801, Armor 400 - 1000, Knight
XL 400 - 1000, Outdoor Knight 151 - 286,
Outdoor Knight XL 400 - 801, Outdoor
Armor 151 - 801,
AQUAS 400 - 801, FTXL 400 - 1000, Wall
Mount 51 - 211, Wall Hung 55 - 399, Wall
Mount Armor 125 - 200, and Shield 125 - 500**

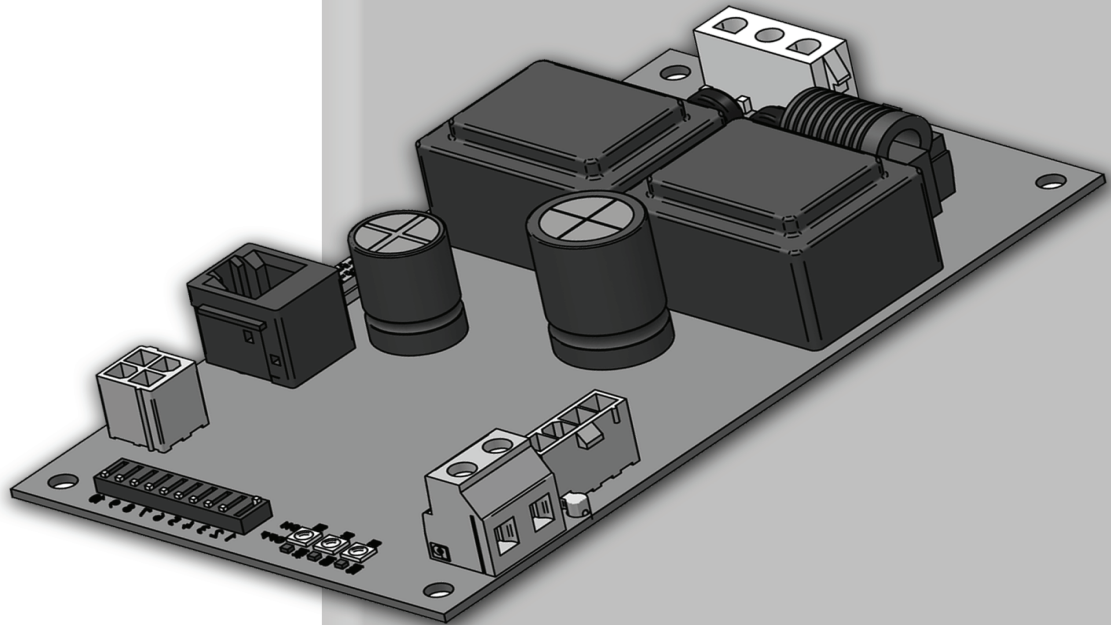

This manual must only be used by a qualified heating installer / service technician. Read all instructions, including this manual, the Installation and Operation Manual, and the Service Manual, before installing. Perform steps in the order given. Failure to comply could result in severe personal injury, death, or substantial property damage.

Contents

<p>1. INTRODUCTION</p> <p style="padding-left: 20px;">Definitions 2</p> <p style="padding-left: 20px;">Minimum System Requirements..... 2</p> <p>2. INSTALLATION</p> <p style="padding-left: 20px;">Wall Mount, Armor, Knight and Knight XL, Outdoor Armor, Outdoor Knight, and Outdoor Knight XL..... 3-4</p> <p style="padding-left: 20px;">FTXL 5</p> <p style="padding-left: 20px;">Wall Hung 6</p> <p style="padding-left: 20px;">Shield 7</p> <p style="padding-left: 20px;">AWH & KBX..... 8</p> <p>3. MODBUS CONFIGURATION</p> <p style="padding-left: 20px;">Addressing..... 9</p> <p style="padding-left: 20px;">Timing Specifications..... 10</p> <p style="padding-left: 20px;">Parity..... 10</p> <p style="padding-left: 20px;">Data Transmission Mode..... 10</p> <p style="padding-left: 20px;">ModBus Board Diagnostics 10</p> <p style="padding-left: 40px;">Internal Faults..... 10</p> <p style="padding-left: 20px;">ModBus Function Set 11</p> <p style="padding-left: 20px;">ModBus Exception Codes 12</p> <p>4. MODBUS MEMORY MAP</p> <p style="padding-left: 20px;">Primary Data Tables..... 13</p> <p style="padding-left: 20px;">Memory Map..... 13-14</p> <p style="padding-left: 40px;">Input Registers 14</p> <p style="padding-left: 40px;">Holding Registers..... 14</p> <p style="padding-left: 20px;">Configuration Bits 14</p>	<p>5. BACNET CONFIGURATION..... 15</p> <p style="padding-left: 20px;">Addressing..... 15</p> <p style="padding-left: 20px;">Timing Specifications..... 16</p> <p style="padding-left: 20px;">Communication Board Diagnostics 16</p> <p style="padding-left: 40px;">Internal Faults..... 16</p> <p>6. BACNET MEMORY MAP</p> <p style="padding-left: 20px;">Primary Data Tables..... 17</p> <p style="padding-left: 20px;">Memory Map..... 17-18</p> <p style="padding-left: 20px;">Input Registers 17</p> <p style="padding-left: 40px;">Holding Registers..... 18</p> <p>7. WIRING REQUIREMENTS</p> <p style="padding-left: 20px;">Physical Wiring 19</p> <p style="padding-left: 20px;">Control Inputs/Outputs..... 20-21</p> <p style="padding-left: 20px;">Control Location..... 22-23</p> <p style="padding-left: 20px;">Typical Boiler/Water Heater System Wiring..... 24</p> <p>8. UNIT OPERATION</p> <p style="padding-left: 20px;">Unit Operation with ModBus Communications..... 25-33</p> <p>9. TROUBLESHOOTING..... 34-35</p> <p>10. DIAGRAMS</p> <p style="padding-left: 20px;">Ladder & Wiring Diagrams 36-51</p> <p style="padding-left: 20px;">Revision Notes Back Cover</p>
---	---

1 Introduction

The information contained in this manual provides general guidelines for the implementation of ModBus and BACnet communication with the Lochinvar Armor water heaters (151 - 801 & 400 - 1000), Wall Mount Armor (125-200), Knight (81-286), Knight XL (400 - 801 & 400 - 1000), Outdoor Knight (151-286), Outdoor Knight XL (400-801), Outdoor Armor (151-801), Wall Mount (51 - 211), and Wall Hung (55 - 399) boilers.

All ModBus networks are implemented utilizing a master-slave arrangement where all boilers/water heaters are slaves and the master is a building automation system capable of communicating over a RS-485 half duplex serial connection. BACnet networks are implemented using a token passing process where multiple masters and slaves share a common RS-485 bus. The Lochinvar BACnet interface is a master only.

Definitions

Abbreviation or Acronym	Meaning
ASCII	American Standard Code for Information Interchange
BACnet	A data communication protocol for Building Automation and Control Networks
BAS	Building Automation System
Baud (Baud Rate)	Number of data bits transmitted per second (bps)
EMS	Energy Management System
FDX	Full-Duplex
HDX	Half-Duplex
Hex	Hexadecimal Number (0 - 9, A - F)
I/O Box	Input/Output (I/O)
LSB	Least Significant Byte
ModBus	A serial, half-duplex data transmission protocol developed by AEG Modicon
MSB	Most Significant Byte
RS232	A standard for serial, full-duplex (FDX) transmission of data based on the RS232 Standard
RS485	A standard for serial transmission of data based on the RS-485 Standard
RTU	Remote Terminal Unit

Minimum System Requirements

- BAS system or computer with a serial or USB port with a converter to RS-485 half duplex.
- Unit equipped with communication board.
- Shielded twisted pair communication cable.

2 Installation

Installation procedure - for Models WB, WA, AW, KB, OA, OK and KBX

1. Turn OFF the main electrical power to the appliance.
2. Turn OFF the main manual gas shutoff to the appliance.
3. Assemble the communication control board to the sheet metal base as shown in FIG. 2-1a and 2-1b, depending on model.
4. Connect the power harness from the appliance to the communication board through the sheet metal cover hole (see FIG. 2-2a and 2-2b, depending on model).
5. Using the two (2) sheet metal screws provided in the kit, attach the pre-painted sheet metal cover over the Communication board for protection from line voltage (FIG. 2-2a and 2-2b, depending on model).
6. Locate the pilot holes on the side of the jacket (left side if AW/KB/KXL or right side if WB/WA), using the sheet metal screws provided in the kit, mount the communication board assembly to the appliance (FIG. 2-3a and 2-3b, depending on model).

Wiring

7. Disconnect power to the transformer by removing connection "B", see FIG. 2-4.
8. Connect A, C, D, and B (FIG. 2-4).
9. Connect the communication board to the control board of the appliance (see FIG. 2-5).
10. Turn on the main electrical power and the main manual gas shutoff to the appliance.
11. Configure the control board and unit controls per this manual and resume operation.

Figure 2-1a Assemble Communication Board for Models WB, WA, AW, KB and KBX

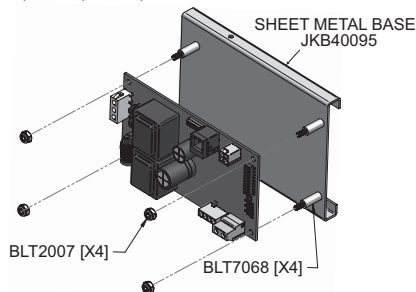

Figure 2-1b Assemble Communication Board for Models OA and OK

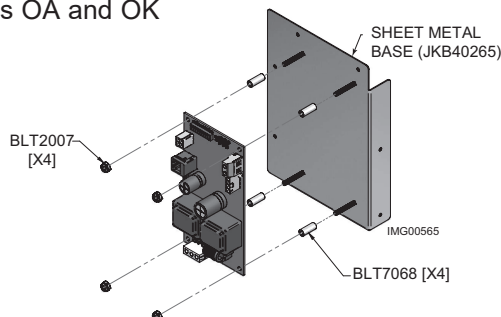

Figure 2-2a Attach Cover to Communication Board for Models WB, WA, AW, KB and KBX

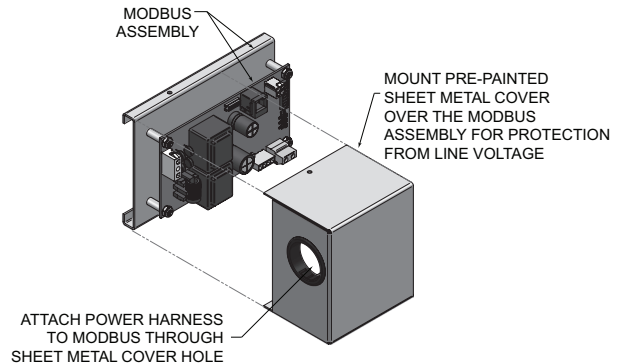

Figure 2-2b Attach Cover to Communication Board for Models OA and OK

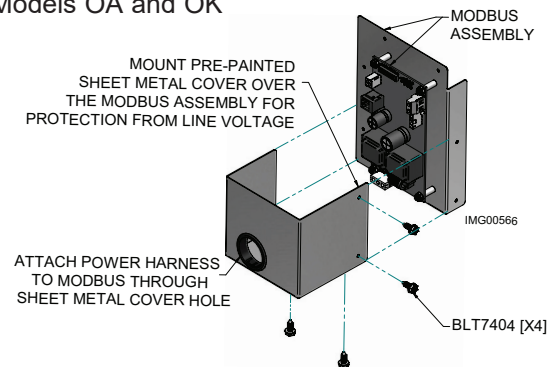
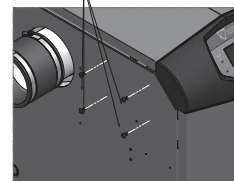

Figure 2-3a Mount Communication board to Unit for Models WB, WA, AW, KB and KBX

- LOCATE THE PILOT HOLES
- USING THE 4 SHEET METAL SCREWS PROVIDED IN THE KIT MOUNT THE MODBUS ASSEMBLY TO THE UNIT (SIDE DEPENDENT ON MODEL)



NOTE: KB/KXL/AW - MOUNT MODBUS ASSEMBLY TO THE LEFT SIDE OF THE JACKET. WB/WA - MOUNT MODBUS ASSEMBLY TO THE RIGHT SIDE OF THE JACKET.

Figure 2-3b Mount Communication board to Unit for Models OA and OK

- LOCATE THE PILOT HOLES
- USING THE (2) SHEET METAL SCREWS PROVIDED IN THE KIT MOUNT THE MODBUS ASSEMBLY TO THE UNIT (SIDE AND ORIENTATION DEPENDENT ON MODEL / VERTICAL ORIENTATION SHOWN)

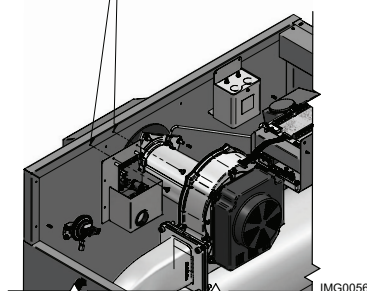

NOTE: OA/OK151 MOUNT MODBUS ASSEMBLY TO THE RIGHT SIDE JACKET FLANGE
OA/OK400-501 MOUNT MODBUS ASSEMBLY IN HORIZONTAL ORIENTATION

2 Installation *(continued)*

Figure 2-4_Harness Connections_WB, WA, AW, KB, KBX, OA, and OK models

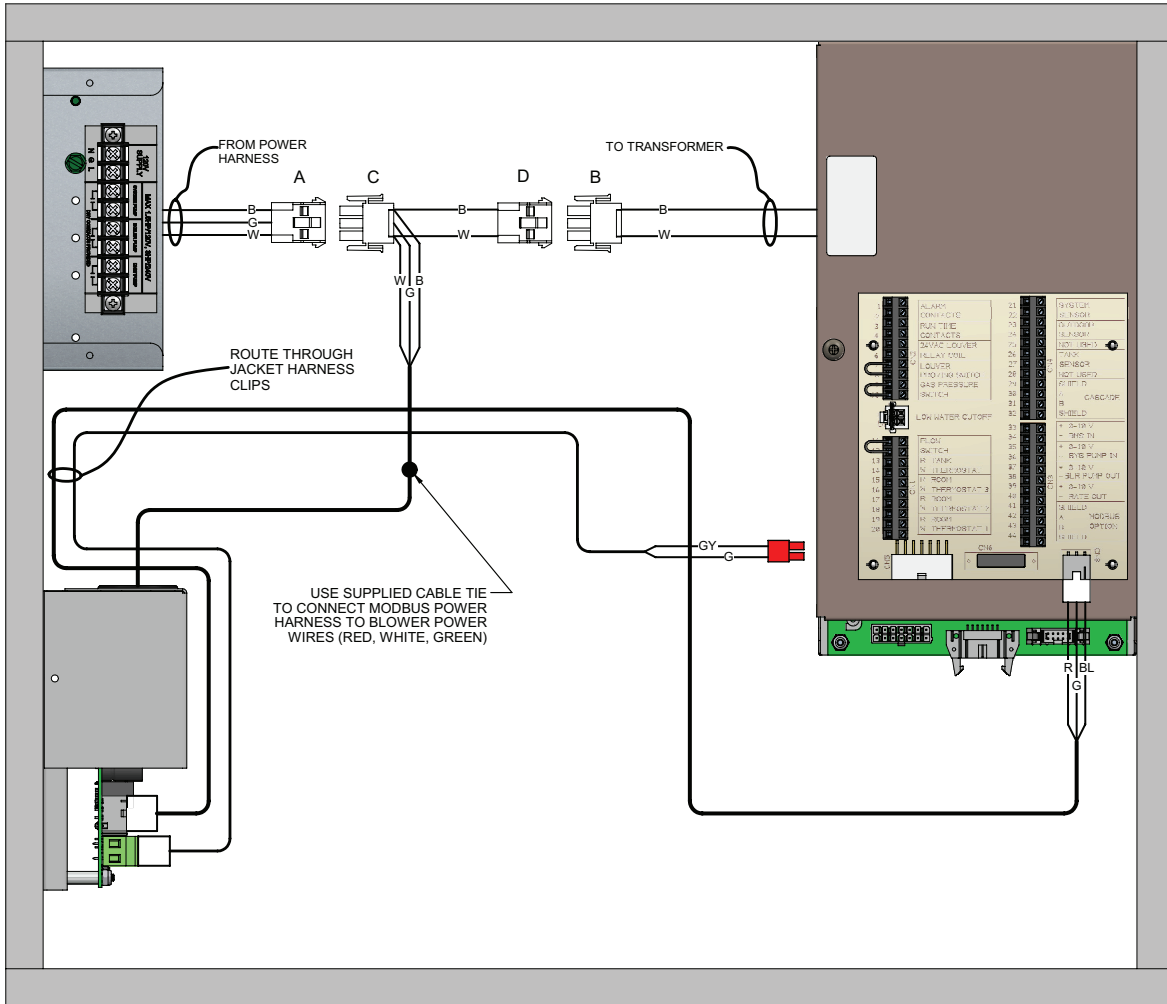
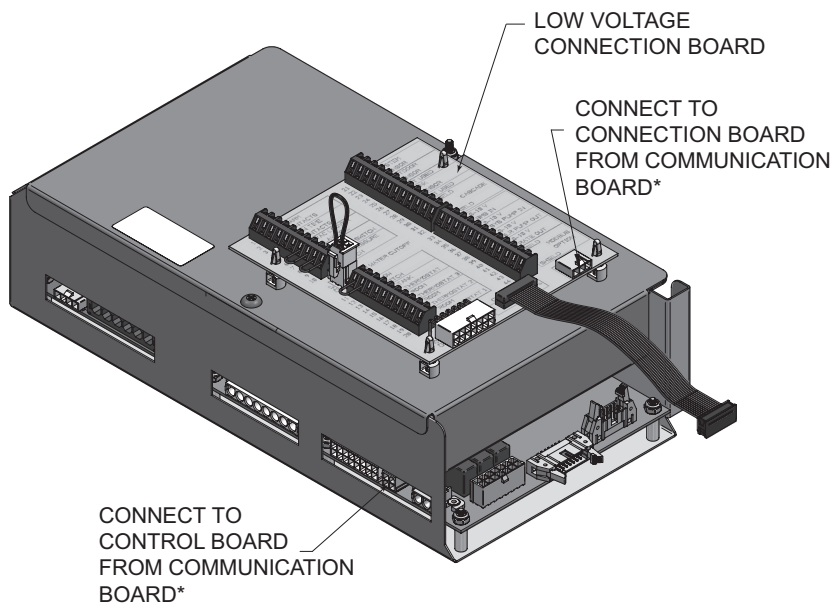

Figure 2-5_Connect Communication Board to Control Board



2 Installation

ModBus installation procedure - for FTXL Models

Figure 2-6a Assemble ModBus Control Board for FTXL

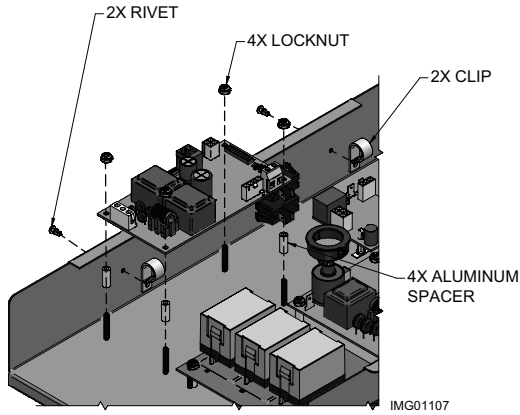

1. Turn OFF the main electrical power to the appliance.
2. Turn OFF the main manual gas shutoff to the appliance.
3. Assemble the ModBus control board and provided cable clamps to the control panel as shown in FIG. 2-6a.
4. Connect the ModBus power, control board and connection board wiring harnesses. Secure the wiring with the provided cable clips and route it through the bottom of the control panel. Perform the wiring connections referencing FIG.'s 2-6b and 2-6c.
5. Turn ON the main electrical power to the appliance.
6. Configure the control board and unit controls per this manual and resume operation.

Figure 2-6b Secure Control Board to FTXL Unit

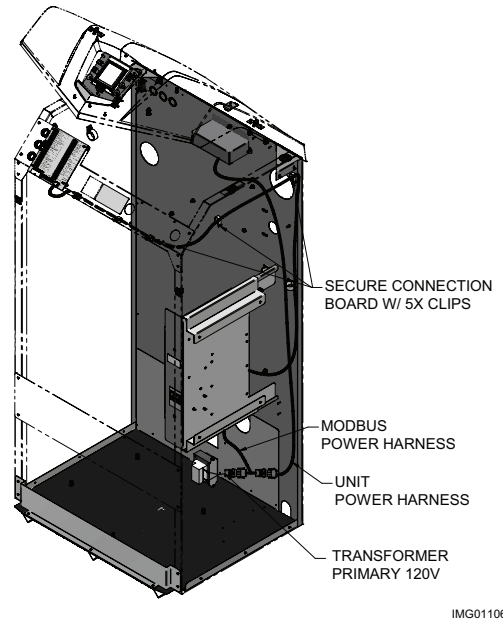
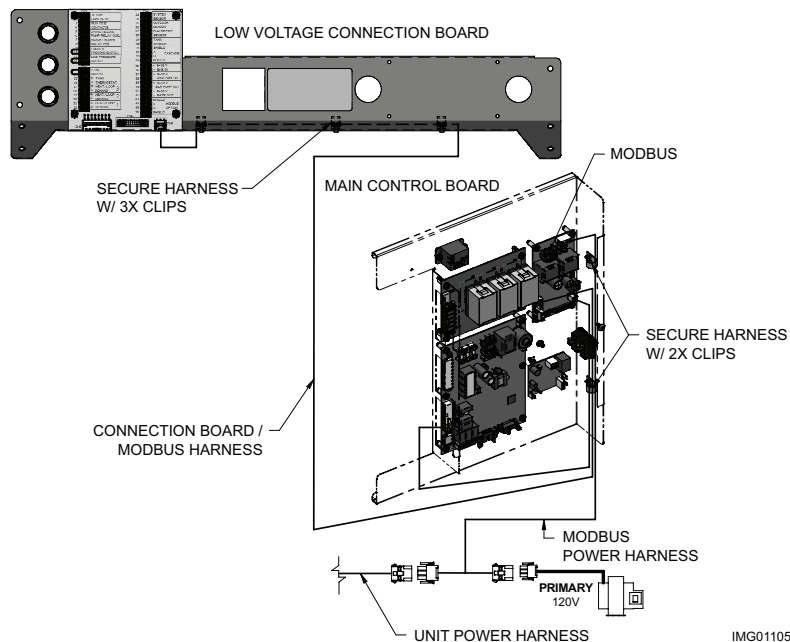

Figure 2-6c Perform Wiring Connections for FTXL



2 Installation

ModBus installation procedure - for Shield Models

Figure 2-8_Assemble ModBus Control Board for Shield

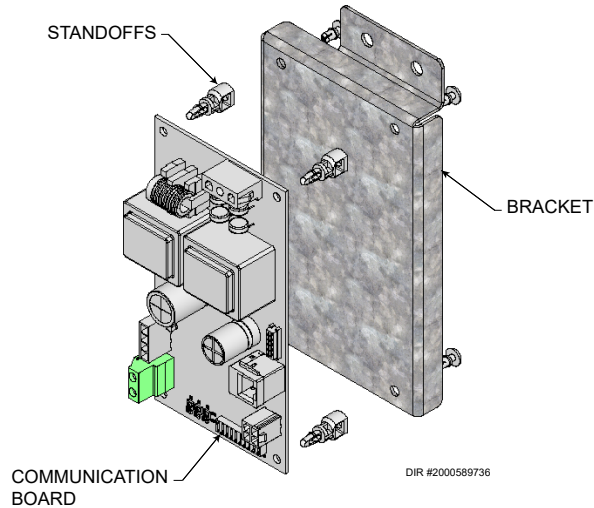

1. Turn OFF the main electrical power to the appliance.
2. Turn OFF the main manual gas shutoff to the appliance.
3. Assemble the communication board to the sheet metal bracket included with this kit by inserting the four (4) standoffs into the sheet metal bracket, as shown in FIG. 2-8.
4. Place the communication board onto the standoffs installed in Step 3 (FIG. 2-8).
5. Use the two (2) screws in this kit to mount the communication board assembly in the appropriate location depending on the model (see FIG.'s 2-9a and 2-9b).
6. Connect the wire harnesses from the appliance to the communication board following the diagram shown in FIG. 2-10.
7. Route the harnesses through the existing harness clips on the heat exchanger frame and/or control panel assembly.
8. Turn ON the main electrical power supply and main gas supply to the appliance.
9. Navigate to the BMS submenu and enable BMS using the instructions in the Shield Installation and Service Manual.
10. Configure the communication board and unit controls per this manual and resume operation.

Figure 2-9a_Secure Control Board to Shield Models SW 125 - 200

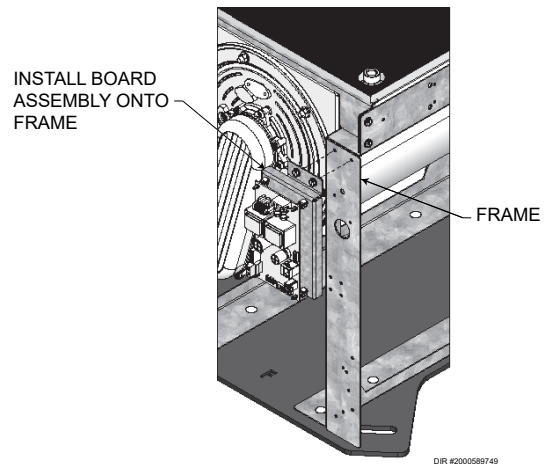

Figure 2-9b_Secure Control Board to Shield Models SW 285 - 500

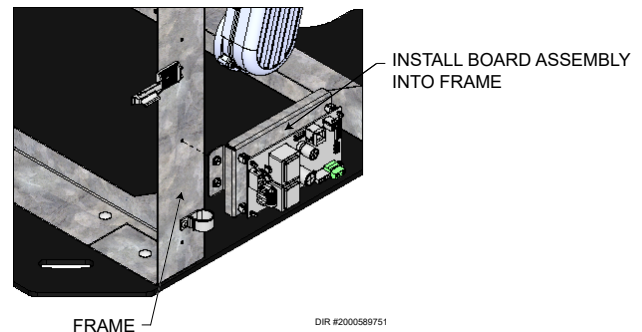
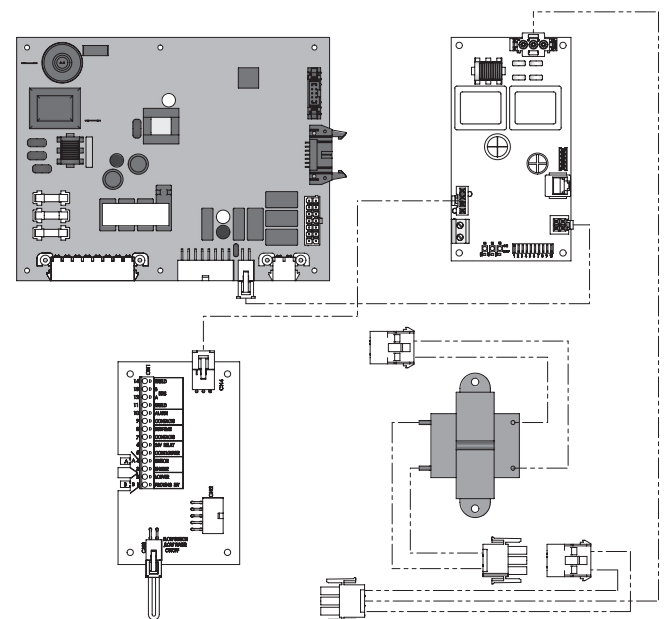

Figure 2-10_Perform Wiring Connections for Shield



2 Installation *(continued)*

ModBus installation procedure - for Armor & Knight XL Models (AWH & KBX)

1. Turn OFF power at the source.
2. Turn OFF gas to the appliance.
3. Remove the front access panel as shown in FIG. 2-11a & 2-11b.
4. Remove cover from the inner control panel (FIG. 2-11a & 2-11b).
5. Place spacers on screws as shown in FIG. 2-11a & 2-11b.
6. Set the address, baud rate, and parity switches on the ModBus board to the desired settings. Refer to the kit-provided ModBus manual for an explanation of these settings.
7. Mount and secure the ModBus board (FIG. 2-12a & 2-12b).
8. Connect the control harness as shown in FIG. 2-12a & 2-12b.
9. Reassemble the appliance.
10. Turn ON all gas, water, and power to the appliance.

Figure 2-11b Remove top access panel and control panel cover - KBX models

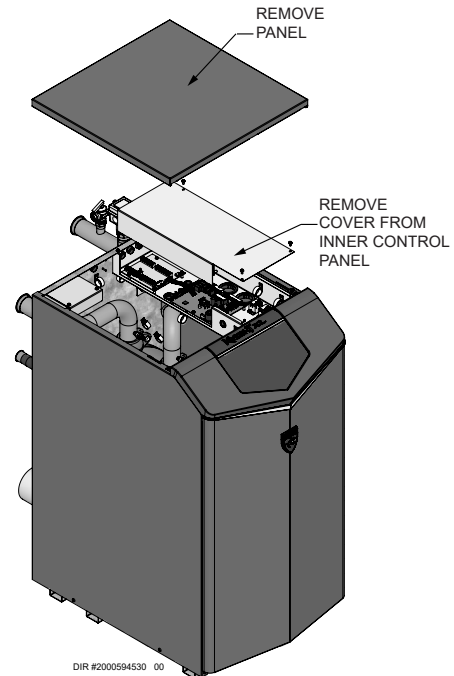

Figure 2-11a Remove top access panel and control panel cover - AWH models

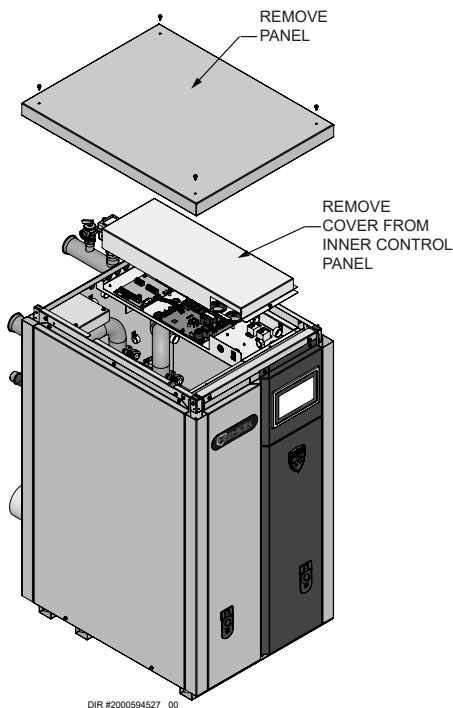

Figure 2-12a Install Modbus board - AWH 400 - 1000 models

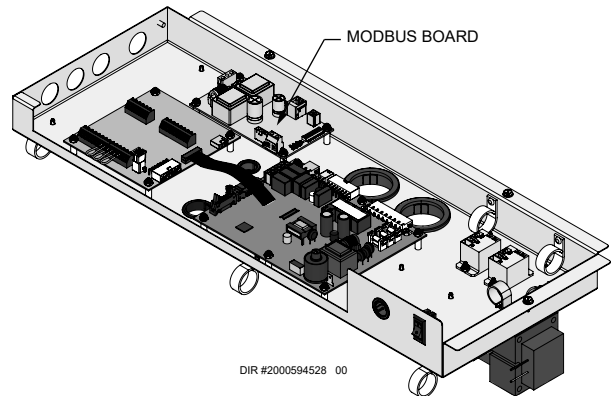
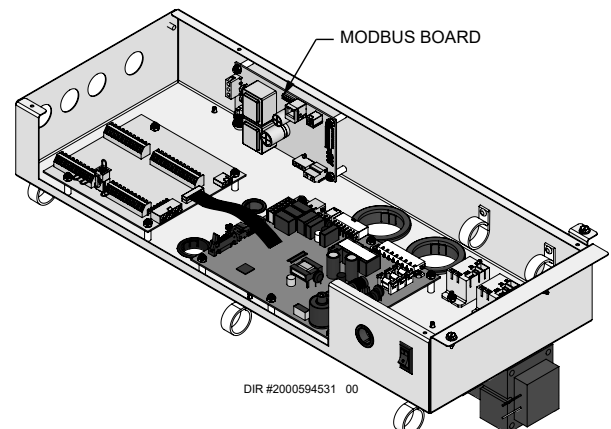

Figure 2-12b Install Modbus board - KBX models



3 ModBus Configuration

The ModBus communication board is equipped with a set of ten dip switches that are used to set the board configuration (address, baud rate, and parity settings). The first eight are used to set the address of each board. The ninth is baud rate. The tenth is parity.

Figure 3-1_ModBus Communication Board

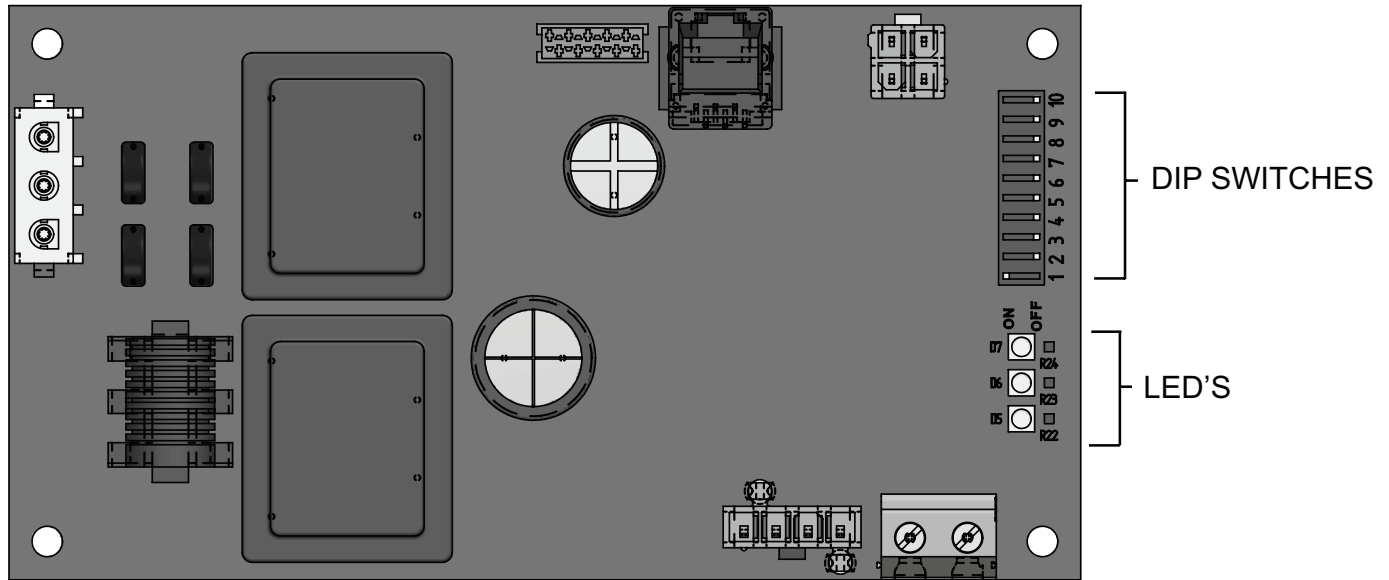

Addressing

The ModBus addressing space is comprised of 256 different addresses.

- Maximum address of 127.

To set the ModBus address the dip switches can be set in either the 0 position or the 1 position. For switches set to the 1 position their value will be added together to determine the address.

Each switch set to the 1 position has the following value:

- Dip switch 1 = 1
- Dip switch 2 = 2
- Dip switch 3 = 4
- Dip switch 4 = 8
- Dip switch 5 = 16
- Dip switch 6 = 32
- Dip switch 7 = 64

Any dip switch set to 0 has a value equal to 0.

Accomplish the different selections with Dip switch #8 on the board. The OFF position displays Celsius while the ON position is Fahrenheit.

Example:

To set the address of the ModBus board to 50, dip switches 2, 5, and 6 have to be set to the 1 position. The address is determined by adding the values of all the dip switches together.

Address = Value of Dip switch 1 + Value of Dip switch 2 + Value of Dip switch 3 + Value of Dip switch 4 + Value of Dip switch 5 + Value of Dip switch 6 + Value of Dip switch 7 + Value of Dip switch 8

In this example:

$$\text{Address} = 0 + 2 + 0 + 0 + 16 + 32 + 0 + 0 = 50$$

3 ModBus Configuration *(continued)*

Timing Specifications

The baud rate for the ModBus board is selectable with Dip switch #9.

- 1 = 19200 bps
- 0 = 9600 bps

Each message is started by at least 3.5 character times of silence. The maximum delay between frames is 1.5 character times.

When the system temperature, tank temperature, and/or 0-10V BMS voltage is provided by the BAS to the boiler, it is critical that the values be updated every few seconds. If the boiler does not receive updated values within a timeout period (installer adjustable), the control will revert to using its own readings (if connected). The timeout is programmable as follows:

NOTICE

Please note that the brackets ([]) denote screen status.

1. Press and hold the LEFT SELECT [MENU] key for 5 seconds.
2. Enter installer code - 5309.
3. Scroll down and select [CONTROL MODES].
4. Scroll down and select [MODBUS T/O].
5. Scroll to desired time. Press the RIGHT SELECT [SAVE] key.

The timeout is adjustable between 5 and 120 seconds. The default timeout is 10 seconds.

When the BAS is not providing any of these values, but is still controlling the boiler (such as providing an enable command), the BAS must refresh these commands at least every 4 minutes. If the commands are not refreshed, the boiler will revert to operating based on its own inputs.

Parity

Parity is set by the position of Dip switch #10.

- 0 = No Parity
- 1 = Even Parity

If No Parity is selected there will be two stop bits, otherwise there will be one.

Data Transmission Mode

Many ModBus bus master devices can be configured to transmit data in either ModBus RTU or ModBus ASCII modes. Since RTU messages can be formatted to use fewer data bits and are therefore more efficient, RTU has been chosen to be used with all Lochinvar ModBus communication. Please ensure that the master device is transmitting ModBus RTU.

ModBus Board Diagnostics

The ModBus board is equipped with three LED's for visual diagnostics: Two yellow LED's and one green. One yellow LED (D5) is used to indicate transmission of data. The other yellow LED (D6) is used to indicate reception of data. The green LED (D7) is used to show internal faults.

Internal Faults:

- Normal Operation = 1 second bright, 1 second dim
- Controller Fault = Continuously on
- No Burner Control Communication = 0.5 seconds on, 1.5 seconds off
- No ModBus Communication = 1.5 seconds on, 0.5 seconds off

ModBus Communication

The ModBus communication commands and exception codes that are supported by the ModBus communication board can be found in this manual.

3 ModBus Configuration

ModBus Function Set

Function		Sub Function	HEX	Description
Dec	HEX	Dec		
1	01			Read Coil Status
2	02			Read Input Status
3	03			Read Holding Registers
4	04			Read Input Registers
5	05			Force Single Coil
6	06			Preset Single Register
7	07			Read Exception Status
8	08	0	00	Diagnostic - Return Query Data
		1	01	Diagnostic - Restart Communication
		2	02	Diagnostic - Return Diagnostic Register
		4	04	Diagnostic - Force Listen Mode
		10	0A	Diagnostic - Clear Counters and Diagnostic Registers
		11	0B	Diagnostic - Return Bus Message Count
		12	0C	Diagnostic - Bus Communication Error Count
		13	0D	Diagnostic - Bus Exception Error Count
		14	0E	Diagnostic - Return Slave Message Count
		15	0F	Diagnostic - Return Communication Error Count
		16	10	Diagnostic - Return Slave NAK Count
		17	11	Diagnostic - Return Slave Busy Count
		18	12	Diagnostic - Return Bus Character Overrun Count
		20	14	Diagnostic - Clear Overrun Counter and Flag
11	0B			Get Communication Event Counter
12	0C			Get Communication Event Log
15	0F			Write Multiple Coils
16	10			Write Multiple Registers
17	11			Report Slave ID
23	17			Read / Write Multiple Registers

3 ModBus Configuration *(continued)*

ModBus Exception Codes

MODBUS Exception Codes		
Code	Name	Meaning
01	ILLEGAL FUNCTION	The function code received in the query is not an allowable action for the server (or slave). This may be because the function code is only applicable to newer devices, and was not implemented in the unit selected. It could also indicate that the server (or slave) is in the wrong state to process a request of this type, for example because it is unconfigured and is being asked to return register values.
02	ILLEGAL DATA ADDRESS	The data address received in the query is not an allowable address for the server (or slave). More specifically, the combination of reference number and transfer length is invalid. For a controller with 100 registers, the PDU addresses the first register as 0, and the last one as 99. If a request is submitted with a starting register address of 96 and a quantity of registers of 4, then this request will successfully operate (address-wise at least) on registers 96, 97, 98, 99. If a request is submitted with a starting register address of 96 and a quantity of registers of 5, then this request will fail with Exception Code 0x02 "Illegal Data Address" since it attempts to operate on registers 96, 97, 98, 99 and 100, and there is no register with address 100.
03	ILLEGAL DATA VALUE	A value contained in the query data field is not an allowable value for server (or slave). This indicates a fault in the structure of the remainder of a complex request, such as that the implied length is incorrect. It specifically does NOT mean that a data item submitted for storage in a register has a value outside the expectation of the application program, since the MODBUS protocol is unaware of the significance of any particular value of any particular register.
04	SLAVE DEVICE FAILURE	An unrecoverable error occurred while the server (or slave) was attempting to perform the requested action.
05	ACKNOWLEDGE	Specialized use in conjunction with programming commands. The server (or slave) has accepted the request and is processing it, but a long duration of time will be required to do so. This response is returned to prevent a timeout error from occurring in the client (or master). The client (or master) can next issue a Poll Program Complete message to determine if processing is completed.
06	SLAVE DEVICE BUSY	Specialized use in conjunction with programming commands. The server (or slave) is engaged in processing a long -- duration program command. The client (or master) should re-transmit the message later when the server (or slave) is free.
08	MEMORY PARITY ERROR	Specialized use in conjunction with function codes 20 and 21 and reference type 6, to indicate that the extended file area failed to pass a consistency check. The server (or slave) attempted to read record file, but detected a parity error in the memory. The client (or master) can retry the request, but service may be required on the server (or slave) device.
0A	GATEWAY PATH UNAVAILABLE	Specialized use in conjunction with gateways, indicates that the gateway was unable to allocate an internal communication path from the input port to the output port for processing as the request. Usually means that the gateway is misconfigured or overloaded.
0B	GATEWAY TARGET DEVICE FAILED TO RESPOND	Specialized use in conjunction with gateways, indicates that no response was obtained from the target device. Usually means that the device is not present on the network.

4 ModBus Memory Map

Primary Data Tables

Table	Data Type	Read / Write
Discrete Inputs	Single Bit	Read Only
Coils	Single Bit	Read / Write
Input Registers	16-Bit Word	Read Only
Holding Registers	16 Bit Word	Read / Write

Memory Map

Coils						
Address	Description	Default	Unit	Min.	Max.	Resolution
00001	Room Thermostat 1	0	1=ON / 0=OFF	0	1	1
00002	Room Thermostat 2	0	1=ON / 0=OFF	0	1	1
00003	Room Thermostat 3	0	1=ON / 0=OFF	0	1	1
00005	Tank Thermostat	0	1=ON / 0=OFF	0	1	1
Discrete Inputs						
10002	Flow Switch	0	1=ON / 0=OFF	0	1	1
10003	Gas Pressure Switch	0	1=ON / 0=OFF	0	1	1
10004	Louver Proving Switch	0	1=ON / 0=OFF	0	1	1
10005	Air Pressure Switch	0	1=ON / 0=OFF	0	1	1
10006	Blocked Drain Switch	0	1=ON / 0=OFF	0	1	1
10007	Auto Reset High Limit	0	1=ON / 0=OFF	0	1	1
10008	Flame	0	1=ON / 0=OFF	0	1	1
10009	Room Thermostat 1	0	1=ON / 0=OFF	0	1	1
10010	Tank Thermostat	0	1=ON / 0=OFF	0	1	1
10024	Room Thermostat 2	0	1=ON / 0=OFF	0	1	1
10033	Run-time Contacts	0	1=ON / 0=OFF	0	1	1
10034	Alarm Contacts	0	1=ON / 0=OFF	0	1	1
10035	CH Pump	0	1=ON / 0=OFF	0	1	1
10036	DHW Pump	0	1=ON / 0=OFF	0	1	1
10037	Louver Relay	0	1=ON / 0=OFF	0	1	1
10038	Gas Valve	0	1=ON / 0=OFF	0	1	1
10039	System Pump	0	1=ON / 0=OFF	0	1	1
10044	DHW Recirculation Pump	0	1=ON / 0=OFF	0	1	1

4 ModBus Memory Map *(continued)*

Memory Map

Input Registers						
Address	Description	Default	Unit	Min.	Max.	Resolution
30001	Discrete Inputs 1 - 16	0	HEX	0	65535	1
30002	Discrete Inputs 17 - 32	0	HEX	0	65535	1
30003	Discrete Inputs 33 - 48	0	HEX	0	65535	1
30004	System / Cascade Setpoint	0	Degrees Celsius	0	130	0,5
30005	System Pump Speed	0	%	0	100	1
30006	Cascade Total Power	0	%	100	800	1
30007	Cascade Current Power	0	%	0	800	1
30008	Outlet Setpoint	0	Degrees Celsius	0	130	0,5
30009	Outlet Temperature	0	Degrees Celsius	0	130	0,1
30010	Inlet Temperature	0	Degrees Celsius	-20	130	0,1
30011	Flue Temperature	0	Degrees Celsius	-20	130	0,1
30012	Firing Rate	0	%	0	100	1
30013	Boiler Pump Speed	0	%	0	100	1
30014	Boiler Status Code	0	HEX	0	65535	1
30015	Boiler Blocking Code	0	HEX	0	65535	1
30016	Boiler Lockout Code	0	HEX	0	65535	1
Holding Registers						
40001	Configuration	0	NA	0	65535	1
40002	Coils	0	NA	0	65535	1
40003	0-10 Volt Input / Rate Command / Setpoint Command	0	%	0	100	1
40004	Tank Setpoint	0	Degrees Celsius	0	87,5	0,5
40005	Tank Temperature	0	Degrees Celsius	-20	130	0,1
40006	Outdoor Temperature	0	Degrees Celsius	-40	60	0,1
40007	System Supply Temperature	0	Degrees Celsius	-20	130	0,1
40008	DHW Recirculation Temperature	0	Degrees Celsius	-20	130	0,1

Configuration Bits

Address 40001 contains configuration bits sent from the BAS to the appliance. These bits tell the boiler/water heater to use its own internal inputs, or inputs from the BAS. When a bit is set to 1, the boiler/water heater will ignore the corresponding value contained internally, and expect the BAS to write that value into the Holding Registers. The configuration bits are as follows:

Bit 0 (LSB): Boiler Enable

Bit 1: Tank Thermostat

Bit 2: Rate Command / 10 - 10V Input / Setpoint Command

Bit 3: Tank Setpoint

Bit 4: System Supply Temperature

Bit 5: Outdoor Temperature

Bit 6: Tank Temperature

Bit 7: System Return Temperature

Bit 8 - 15: Not Used (Default = 0)

5 BACNET Configuration

The BACnet communication board is equipped with a set of ten dip switches that are used to set the board configuration (address and baud rate). The first eight are used to set the address of each board. The ninth and tenth are baud rate.

Figure 5-1_Communication Board

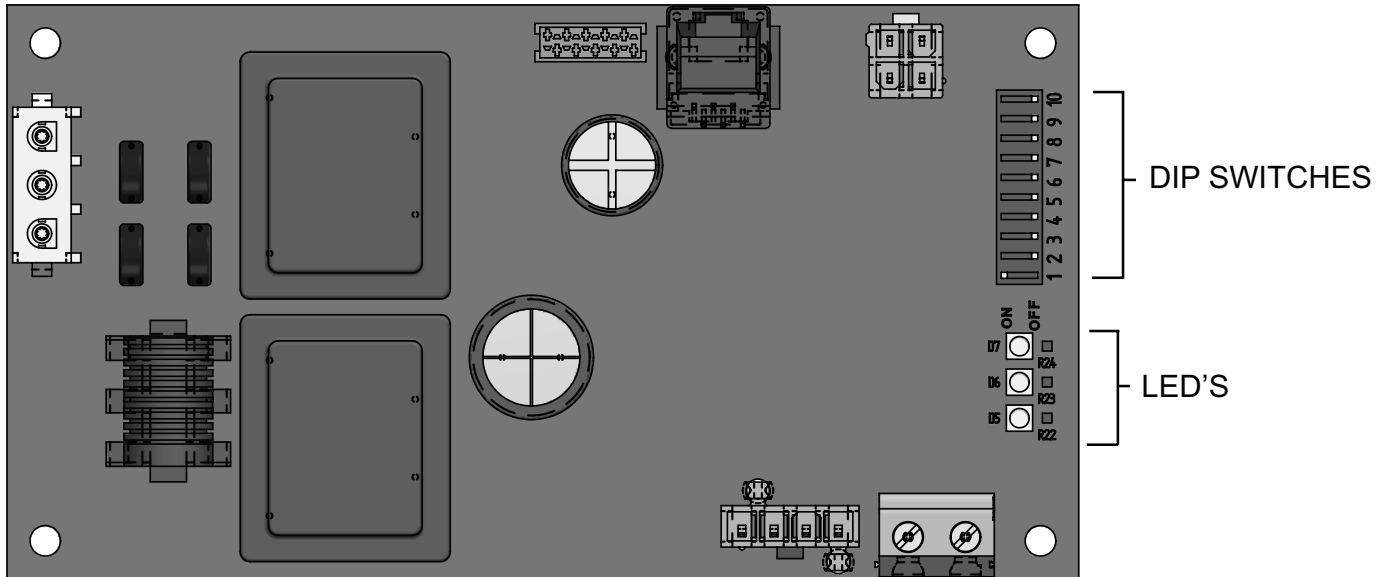

Addressing

The BACnet local addressing space is comprised of 256 different addresses.

- 255 is reserved for broadcast messages from a master device.
- 128 - 254 are free to use for slave devices only.
- 0 - 127 are free to use for master or slave devices.

Since the BACnet communication board is a BACnet master, address 127 is the highest address that can be used.

To set the BACnet local address, the dip switches can be set in either the 0 position or the 1 position. For switches set to the 1 position their value will be added together to determine the address.

Each switch set to the 1 position has the following value:

- Dip switch 1 = 1
- Dip switch 2 = 2
- Dip switch 3 = 4
- Dip switch 4 = 8
- Dip switch 5 = 16
- Dip switch 6 = 32
- Dip switch 7 = 64
- Dip switch 8 = 128

Any dip switch set to 0 has a value equal to 0.

Example:

To set the address of the BACnet board to 50, dip switches 2, 5, and 6 have to be set to the 1 position. The address is determined by adding the values of all the dip switches together.

Address = Value of Dip switch 1 + Value of Dip switch 2 + Value of Dip switch 3 + Value of Dip switch 4 + Value of Dip switch 5 + Value of Dip switch 6 + Value of Dip switch 7 + Value of Dip switch 8

In this example:

$$\text{Address} = 0 + 2 + 0 + 0 + 16 + 32 + 0 + 0 = 50$$

The BACnet Device Instance is calculated by adding the BACnet local address to 600000. Using the above example, the Device Instance will be:

$$\text{Device Instance} = 600000 + 50 = 600050$$

The base address (600000 in this example) is model dependant and can be changed by the integrator. It can be set to any value between 0 and 4194048. The resulting device instance will be this value + the local address, as before. Once the base address is changed, it can be reset back to the default base address (600000 in this example) using the following procedure:

1. Turn OFF power to the interface board.
2. Set Dip switches 1 - 8 to the 1 position.
3. Turn ON power to the interface board.
4. After a few seconds, turn OFF power to the interface board.
5. Set Dip switches 1 - 7 to the desired local address. Set Dip switch 8 to the 0 position.
6. Turn ON power to the interface board.

Device Name

The default device name is "MTR-01 BACnet." This can be changed by the integrator as desired.

5 BACnet Configuration *(continued)*

Timing Specifications

The baud rate for the BACnet board is selectable with Dip switches #9 and #10.

Switch #9	Switch#10	Baud Rate
OFF	OFF	9600
ON	OFF	19200
OFF	ON	38400
ON	ON	76800

When the system temperature, tank temperature, and/or 0-10V BMS voltage is provided by the BAS to the boiler, it is critical that the values be updated every few seconds. If the boiler does not receive updated values within a timeout period (installer adjustable), the control will revert to using its own readings (if connected). The timeout is programmable as follows:

NOTICE

Please note that the brackets ([]) denote screen status.

1. Press and hold the LEFT SELECT [MENU] key for 5 seconds.
2. Enter installer code - 5309.
3. Scroll down and select [CONTROL MODES].
4. Scroll down and select [MODBUS T/O].
5. Scroll to desired time. Press the RIGHT SELECT [SAVE] key.

The timeout is adjustable between 5 and 120 seconds. The default timeout is 10 seconds.

When the BAS is not providing any of these values, but is still controlling the boiler (such as providing an enable command), the BAS must refresh these commands at least every 4 minutes. If the commands are not refreshed, the boiler will revert to operating based on its own inputs.

Communication Board Diagnostics

The Communication board is equipped with three LED's for visual diagnostics: Two yellow LED's and one green. One yellow LED (D5) is used to indicate transmission of data. The other yellow LED (D6) is used to indicate reception of data. The green LED (D7) is used to show internal faults.

Internal Faults:

Normal Operation = 1 second bright, 1 second dim

Controller Fault = Continuously on

No Burner Control Communication = 0.5 seconds on, 1.5 seconds off

No BACnet Communication = 1.5 seconds on, 0.5 seconds off.

6 BACnet Memory Map

Primary Data Tables

Object Type	Data Type	Read / Write
Binary Input (BI)	Single Bit	Read Only
Binary Value (BV)	Single Bit	Read / Write
Analog Input (AI)	16-Bit Word	Read Only
Analog Value (AV)	16 Bit Word	Read / Write

Memory Map

Object Name	Object Type	Object Instance	Units	Min	Max	Resolution
Binary Values						
Boiler Enable / Room Th. 1	BV	0	none	0	1	1
Room Th.2	BV	1	none	0	1	1
Room Th.3	BV	2	none	0	1	1
Tank Thermostat	BV	4	none	0	1	1
Binary Inputs						
Flow Switch	BI	1	none	0	1	1
Gas Pressure Switch	BI	2	none	0	1	1
Louver Proving Switch	BI	3	none	0	1	1
Air Pressure Switch	BI	4	none	0	1	1
Blocked Drain Switch	BI	5	none	0	1	1
Auto Reset High Limit	BI	6	none	0	1	1
Flame	BI	7	none	0	1	1
Room Thermostat 1	BI	8	none	0	1	1
Tank Thermostat	BI	9	none	0	1	1
Room Thermostat 2	BI	23	none	0	1	1
Run Time Contacts	BI	32	none	0	1	1
Alarm Contacts	BI	33	none	0	1	1
Boiler Pump	BI	34	none	0	1	1
DHW Pump	BI	35	none	0	1	1
Louver Relay	BI	36	none	0	1	1
Gas Valve	BI	37	none	0	1	1
System Pump	BI	38	none	0	1	1
Inputs						
BI Inputs 0 - 15	AI	0	none	0	1	1
BI Inputs 16 - 31	AI	1	none	0	1	1
BI Inputs 32 - 47	AI	2	none	0	1	1
System / Cascade Setpoint	AI	3	Deg C	0	1	0.5
System Pump Speed	AI	4	Percent	0	1	1
Cascade Total Power	AI	5	Percent	0	1	1
Cascade Current Power	AI	6	Percent	0	1	1
Outlet Setpoint	AI	7	Deg C	0	1	0.5
Outlet Temperature	AI	8	Deg C	0	1	0.1
Inlet Temperature	AI	9	Deg C	0	1	0.1

6 BACnet Memory Map *(continued)*

Memory Map *(continued)*

Object Name	Object Type	Object Instance	Units	Min	Max	Resolution
Flue Temperature	AI	10	Deg C	-20	130	0.1
Firing Rate	AI	11	Percent	0	100	1
Boiler Pump Speed	AI	12	Percent	0	100	1
Boiler Status Code	AI	13	none	0	65535	1
Boiler Blocking Code	AI	14	none	0	65535	1
Boiler Lockout Code	AI	15	none	0	65535	1
Analog Values						
Configuration	AV	0	none	0	65535	1
BV 0-4	AV	1	none	0	65535	1
0-10V BMS Input	AV	2	Percent	0	100	1
Tank Setpoint	AV	3	Deg C	0	87.5	0.5
Tank Temperature	AV	4	Deg C	-20	130	0.1
Outdoor Temperature	AV	5	Deg C	-40	60	0.1
System Supply Temperature	AV	6	Deg C	-20	130	0.1

7 Wiring Requirements

Note that when the System Supply Temperature and/or the Tank Temperature are provided by the BAS, they need to be refreshed every few seconds. This is required in order to prevent unwanted fluctuations in these temperatures. If these values are not provided every few seconds (timeout is programmable), the boiler will revert to its own internal control. If neither of these temperatures is provided by the BAS, but any of the other control signals are being provided, the BAS will still need to refresh these inputs at least every 4 minutes.

Physical Wiring

RS-485 Communication Bus

- Maximum Length = 4000 feet
- Cable Specification = 24 AWG / A,B (twisted pair) and GND Shielded, with characteristic Impedance = 120 ohm
- Maximum Load = 32 units (32 nodes)

NOTE: Cable must be terminated with 120 ohm impedance matching resistor on each end.

A + (positive)
B - (negative)

Figure 7-1_Terminal Strip Connections

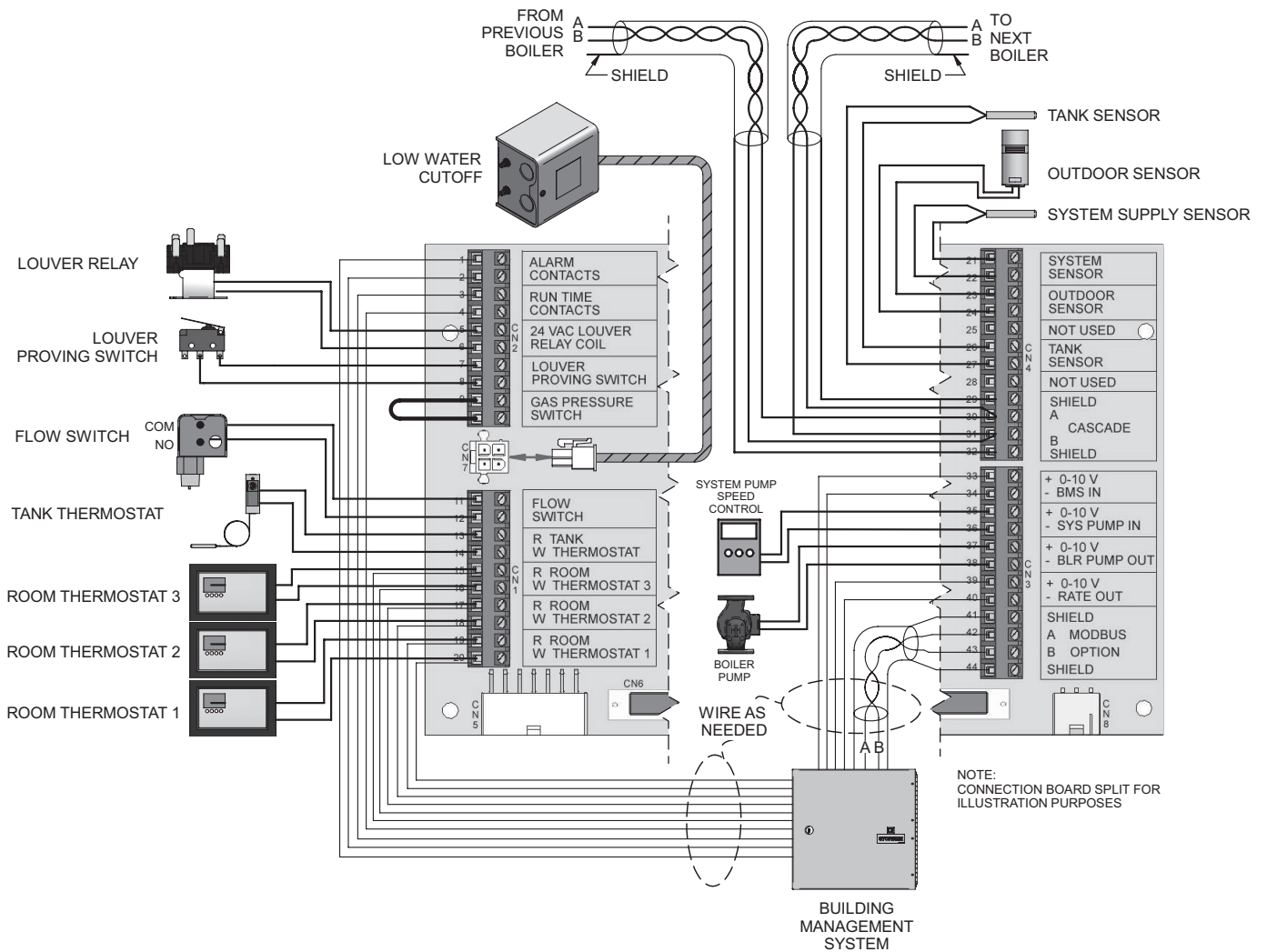

7 Wiring Requirements *(continued)*

Figure 7-2_Control Inputs

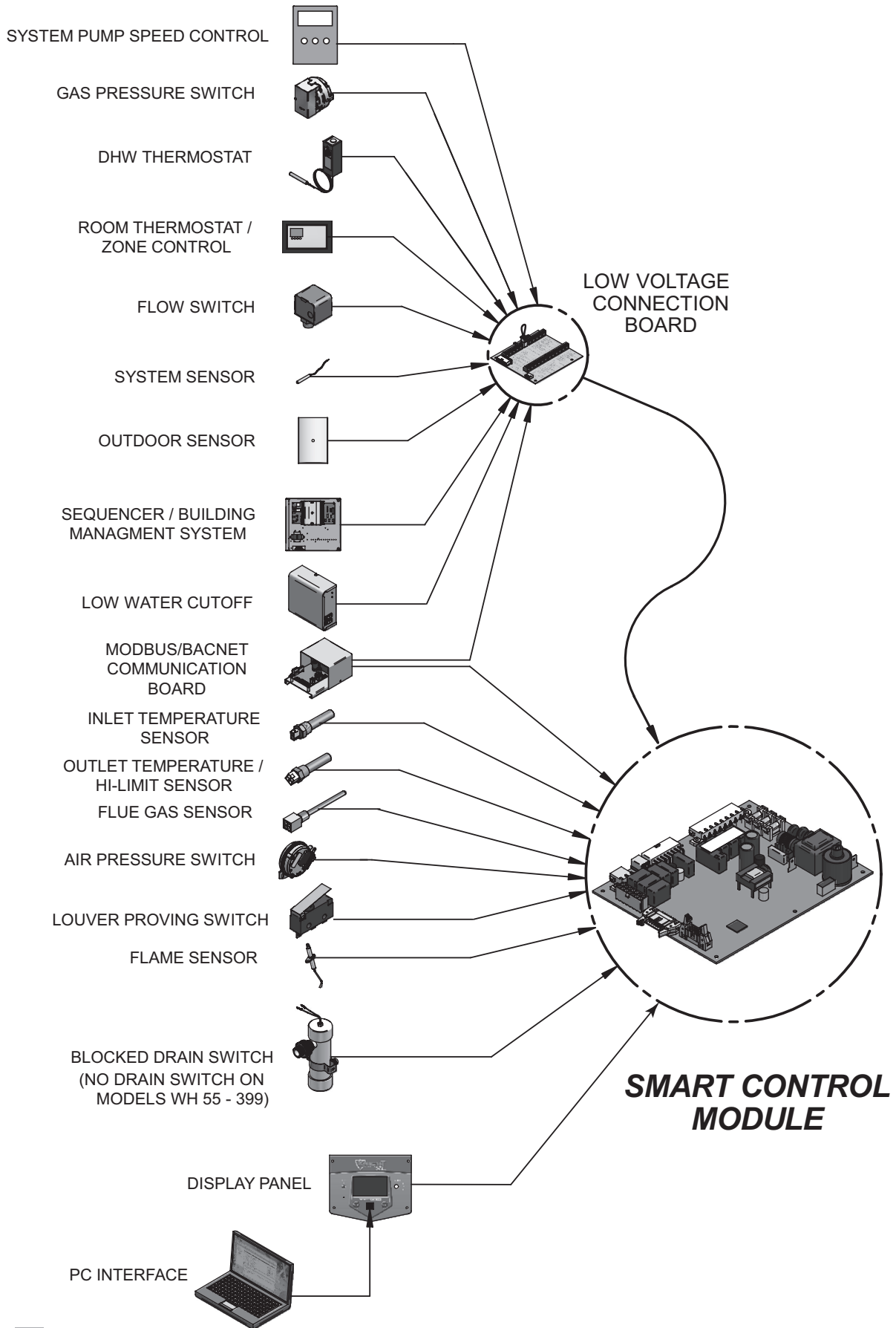

7 Wiring Requirements

Figure 7-3_Control Outputs

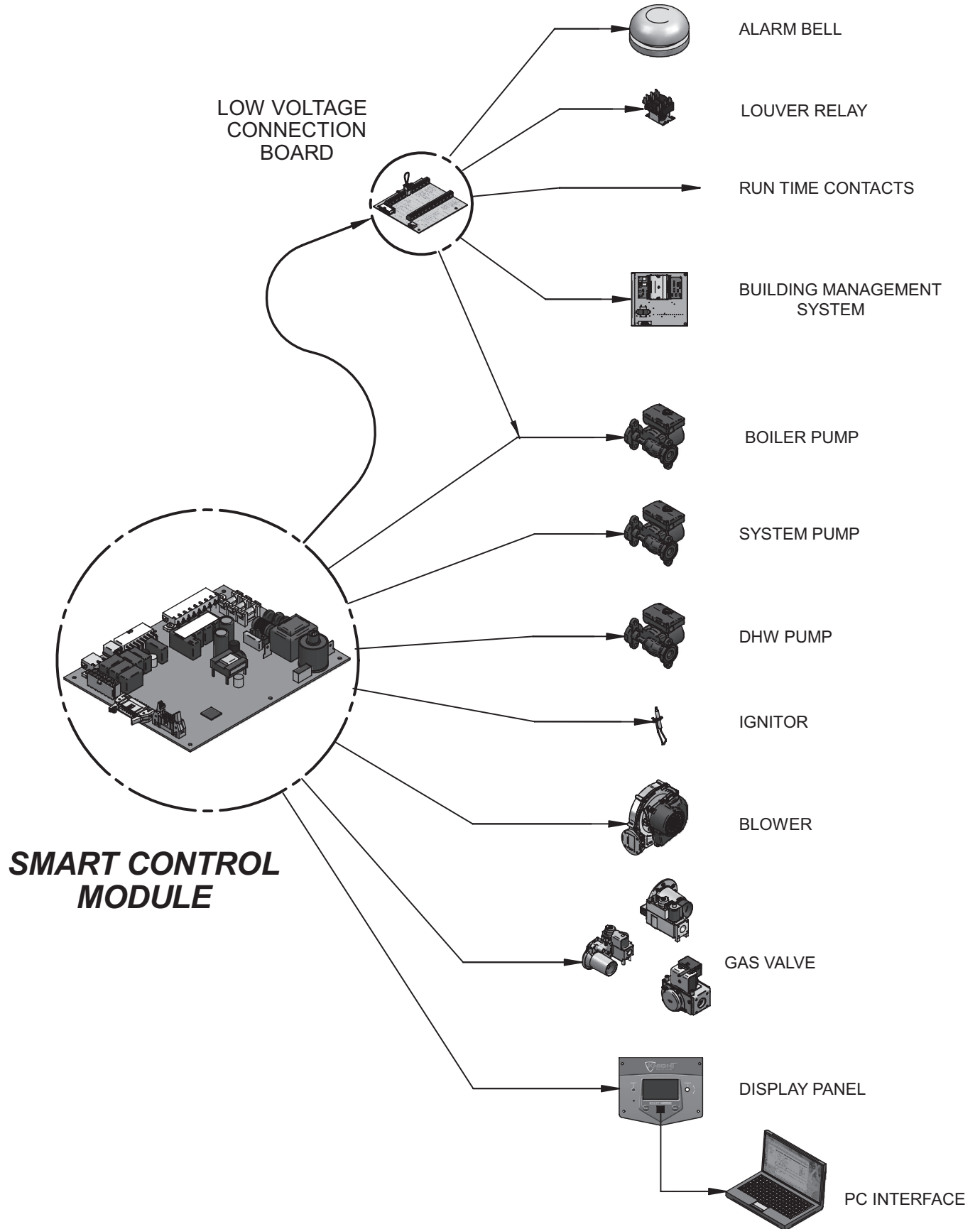

7 Wiring Requirements *(continued)*

Figure 7-4_Control Location_Knight , Knight XL and Armor

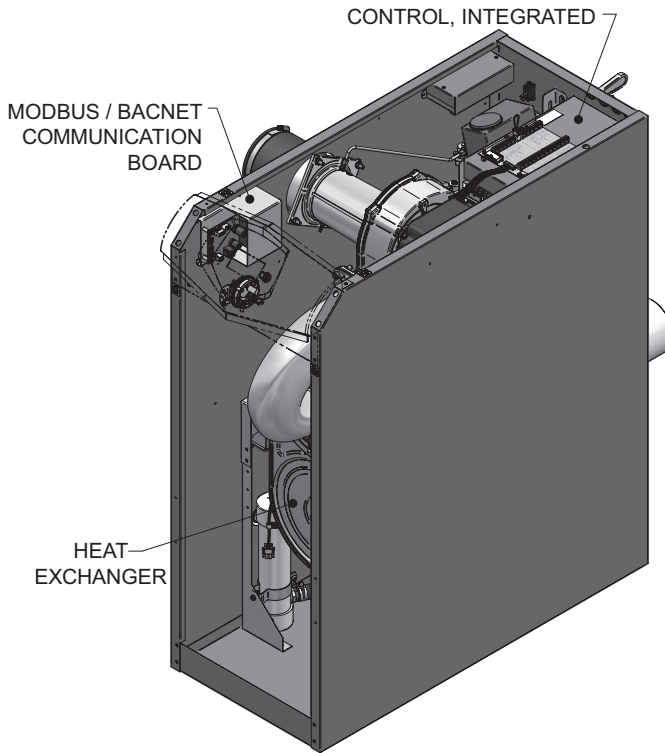

Figure 7-5_Control Location_Outdoor Knight, Outdoor Knight XL, Outdoor Armor

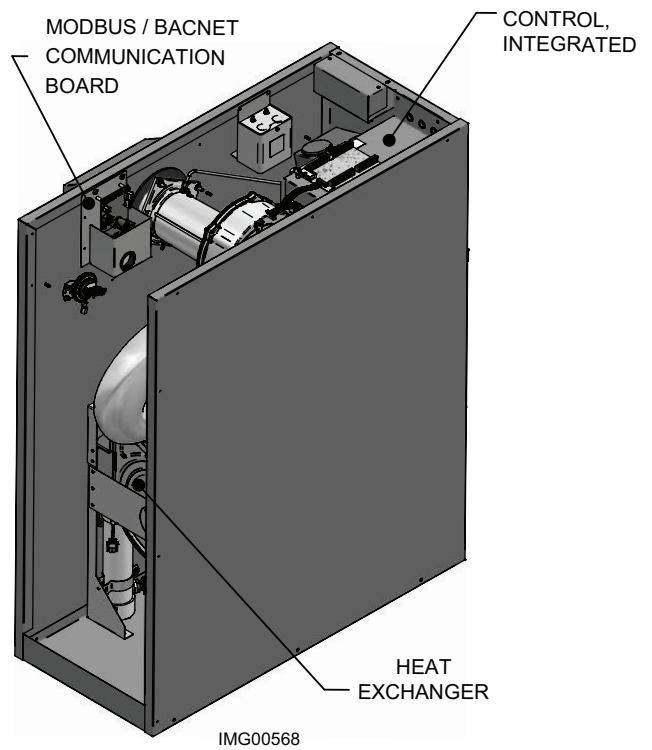

Figure 7-6_Control Location_Knight/Armor Wall Mount

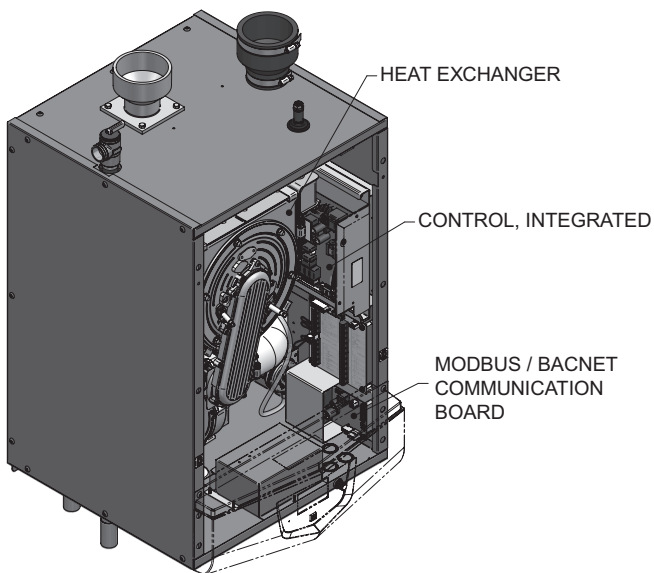
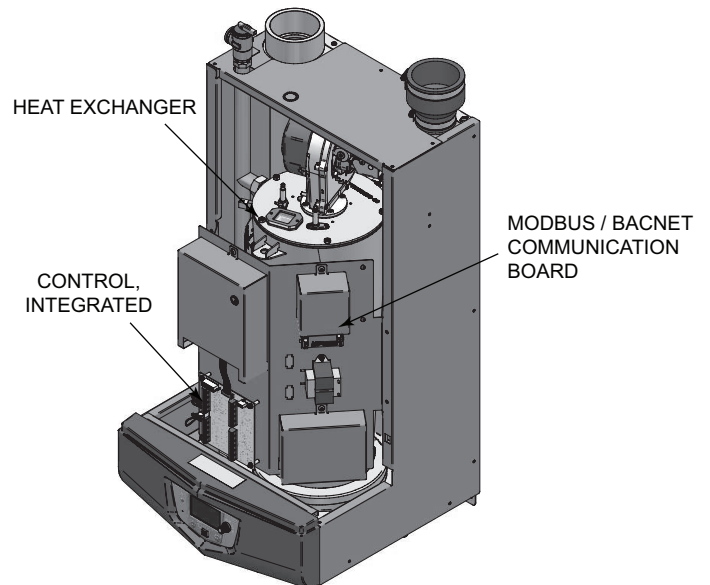

Figure 7-7_Control Location_Knight Wall Hung



7 Wiring Requirements

Figure 7-8_Control Location_FTXL

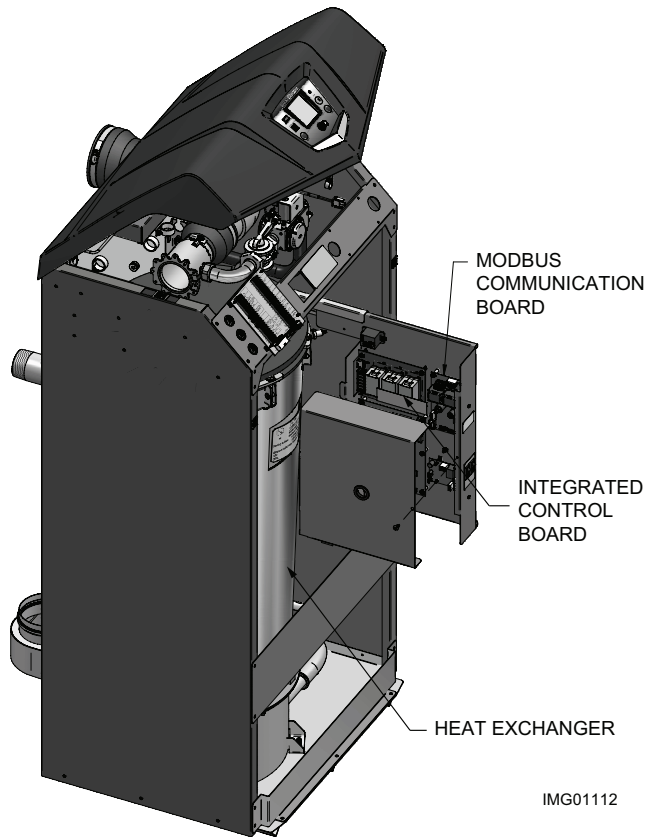

Figure 7-9_Control Location_Armor

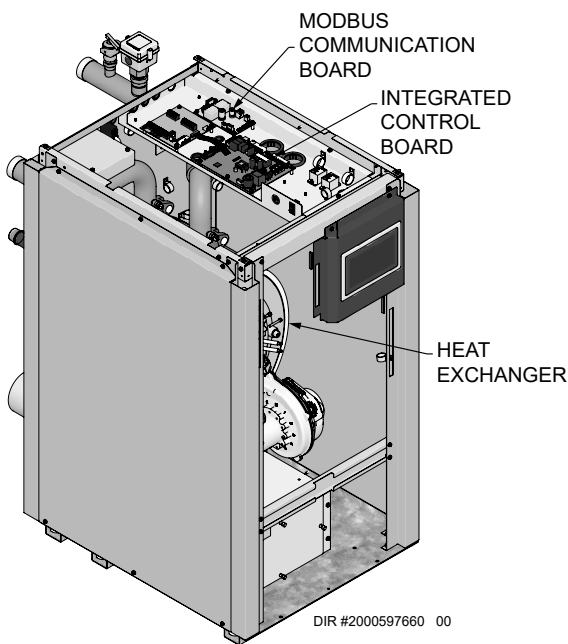
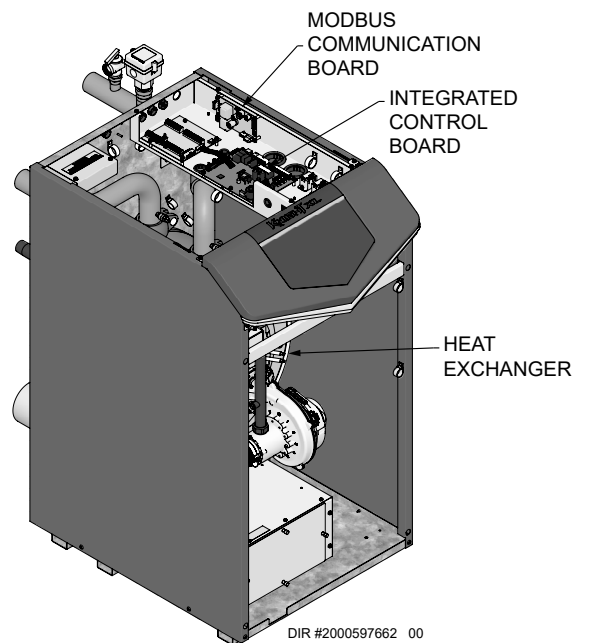

Figure 7-10_Control Location_Knight XL



7 Wiring Requirements *(continued)*

Typical Boiler/Water Heater System Wiring

Physical Configuration: Cascade without Individual Monitoring

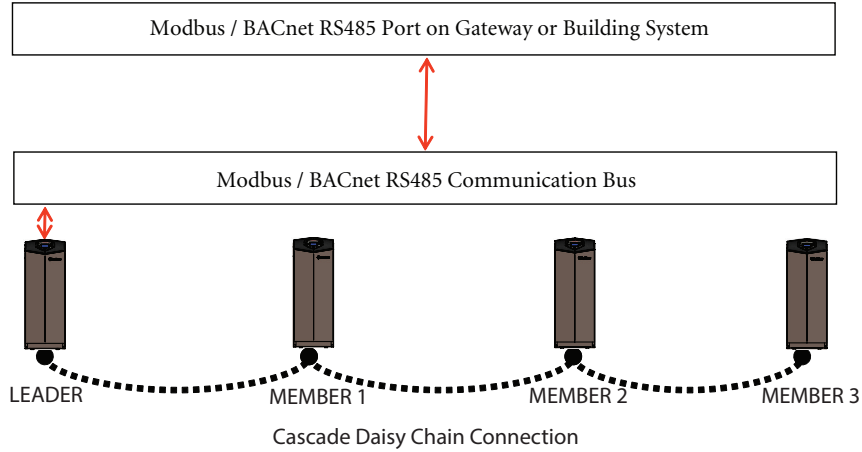

NOTICE You will need a Modbus or BACnet board only for the Leader.

Physical Configuration: Cascade with individual Monitoring

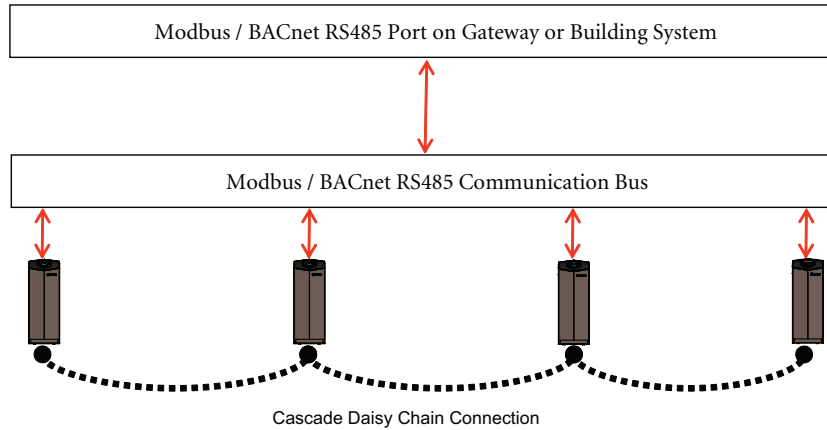

NOTICE You will need a Modbus or BACnet board for all appliances.

Physical Configuration: Direct Control

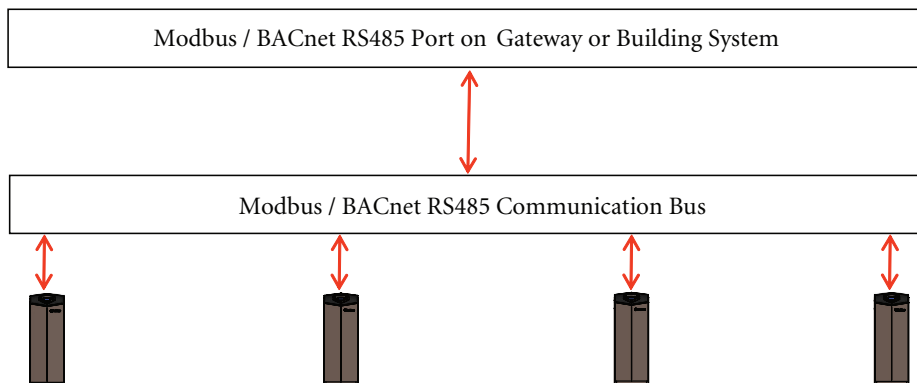

NOTICE You will need a Modbus or BACnet board for all appliances.

8 Unit Operation - KB, KH, WH, OK, AW, WA, OA, FTXL, Shield, & AQUAS Models

Unit Operation with ModBus or BACnet Communications

To control a boiler/water heater through a Building Management System communicating through ModBus or BACnet, the boiler/water heater control mode must be properly configured. These configurations allow different control points for a variety of applications. There are five (5) configuration parameters that need to be set.

General Set-up

NOTICE

Please note that the brackets ([]) denote screen status.

1. Press and hold LEFT SELECT [MENU] key.
2. Enter installer code - 5309.
3. Scroll down and select [CONTROL MODES].
4. Select ModBus or BACnet by pressing the NAVIGATION dial.
5. Scroll to ACTIVE.
6. Press the RIGHT SELECT [SAVE] key.
7. Exit one level.
8. Choose the appropriate Control Mode and continue set-up to complete.

Figure 8-1_Control Modes (Default)

```

SHUTDOWN
>CONT SENSOR: OUT/SYS
BMS TSTAT      INACTIVE
BMS             INACTIVE
MODBUS         INACTIVE
EXIT           ↓SELECT  HOME
  
```

Figure 8-2_Control Modes - ModBus Active

```

SHUTDOWN
CONT SENSOR    OUT/SYS
BMS TSTAT      INACTIVE
BMS            INACTIVE
>MODBUS        ACTIVE
EXIT           ↻ADJUST  SAVE
  
```

The boiler/water heater is equipped with a ModBus communication timer. This timer is programmable from 0 - 120 seconds. The timer can be programmed in the ModBus T/O Menu, reference Section 3 - Timing Specifications of this manual. The purpose of the timer is to ensure proper temperature data is communicated to the boiler/water heater in a timely manner. Additionally, it will provide for fail safe operation should BMS communication be lost. This timer will cause the unit to revert back to internal unit controls should the BMS communication be interrupted longer than the ModBus timer. The timer is reset every time a write command is received with updated temperatures or commands. It is the recommendation of Lochinvar that this timer be set to the shortest value possible.

When operating off the BMS communication bus and with remote sensors connected to the Building Automation System (BAS), it is very important to ensure that the correct configuration bits are sent to holding register 40001 (ModBus) or AVO(BACnet), and that the correct data and enable signals are sent to holding registers 40002 - 40008 (ModBus) or AVO(BACnet), per the control mode.

Control Mode 1

In this configuration the unit is controlled by setting the set points locally on the boiler/water heater and providing an enable signal through BMS communications.

All sensors and limiting devices should be hardwired to the terminal strip on the back of the unit excluding the thermostat enable and tank thermostat enable signal. These signals will be sent to the unit via ModBus or BACnet.

8 Unit Operation - KB, KH, WH, OK, AW, WA, OA, FTXL, Shield, & AQUAS Models *(continued)*

Control Mode 1 - Set-up (Configuration Parameters)

BMS Type default (FIG. 6-3) remains.

Object	Holding Registers	Definition	Bit Value (HEX)	Action
AV0	40001	Configuration	00 01	Set Configuration to read 40002
AV1	40002	Coils / BV	00 01	Enables unit (<i>00 00 disables unit</i>)

NOTE: To ensure proper operation re-send the configuration bits to holding register 40001 or object AV0 prior to issuing a command.

Control Mode 2

In this configuration the unit is controlled by setting the set points locally on the boiler/water heater and providing an enable signal and a rate command through ModBus or BACnet communications.

The BMS Type will be 0 - 100% of modulation or a temperature set point.

Control Mode 2 - Set-up (Configuration Parameters)

To Set BMS Type:

- While still in Installer Menu Set, scroll down and select [BMS] by pressing the NAVIGATION dial.
- In the BMS Menu, select [BMS TYPE], scroll to [POWER] or [SETPOINT] and press the RIGHT SELECT [SAVE] key.

Reference FIG.'s 6-3 and 6-4 to set BMS Type to the appropriate operation.

Figure 8-3_BMS Type - Set Point (Default) (KB screen shown for illustration purposes only)

```

SHUTDOWN
>BMS TYPE      SETPOINT
VOLTS @ MIN    2.00
VOLTS @ MAX    10.00
RATE @ MIN U   20%
-----
EXIT          ↓SELECT  HOME

```

Figure 8-4_BMS Type - Power (KB screen shown for illustration purposes only)

```

SHUTDOWN
>BMS TYPE      POWER
VOLTS @ MIN    2.00
VOLTS @ MAX    10.00
RATE @ MIN U   20%
-----
EXIT          ↻ ADJUST  SAVE

```

All sensors and limiting devices should be hardwired to the terminal strip on the back of the unit excluding the thermostat enable and tank thermostat enable signal. These signals will be sent to the unit via ModBus.

Control Mode 2 - Set-up (Command Parameters)

- While in the Control's Installer Main Menu, select [CONTROL MODES].
- In Control Modes Menu select [BMS] and set to [ACTIVE].
- Press the RIGHT SELECT [SAVE] key.

Figure 8-5_Control's Installer Main Menu (KB screen shown for illustration purposes only)

```

SHUTDOWN
CONT SENSOR:  OUT/SYS
BMS TSTAT    INACTIVE
BMS          ACTIVE
MODBUS       ACTIVE
-----
EXIT          ↓SELECT  HOME

```

8 Unit Operation - KB, KH, WH, OK, AW, WA, OA, FTXL, Shield, & AQUAS Models

Control Mode 2 - Set-up (Command Parameters) *(continued)*

The holding registers/objects will need to be set as follows:

Object	Holding Registers	Definition	Bit Value (HEX)	Action
AV0	40001	Configuration	00 05	Set Configuration to read 40002 & 3
AV1	40002	Coils / BV	00 01	Enables unit <i>(00 00 disables unit)</i>
AV2	40003	Rate Command	00 ##	Sets Modulation % or Setpoint

NOTE: To ensure proper operation re-send the configuration bits to holding register 40001 or Object AV0 prior to issuing a command.

For proper hexadecimal conversion of rate percentage or temperature conversion, please refer to the Rate and Temperature Conversions section of this manual.

Control Mode 3

In this configuration the unit is controlled by setting the modulation set point from 0 - 100%. The modulation set point will provide the enable function as well.

The BMS Type will be 0 - 100% of modulation.

Control Mode 3 - Set-up (Configuration Parameters)

Reference FIG.'s 8-3 and 8-4 to set BMS Type to [POWER].

All sensors and limiting devices should be hardwired to the terminal strip on the back of the unit excluding the thermostat enable and tank thermostat enable signal. These signals will be sent to the unit via ModBus.

Control Mode 3 - Set-up (Command Parameters)

1. Enter the installer code - 5309.
2. While in the Control's Installer Main Menu, scroll to and select [CONTROL MODES].
3. In Control Modes Menu select [BMS] and set to [ACTIVE] (see FIG. 6-5).
3. Press the RIGHT SELECT [SAVE] key.

The holding registers/objects will need to be set as follows:

Object	Holding Registers	Definition	Bit Value (HEX)	Action
AV0	40001	Configuration	00 04	Set Configuration to read 40003
AV2	40003	Rate Command	00 00	Sets Modulation %

NOTE: To ensure proper operation re-send the configuration bits to holding register 40001 or Object AV0 prior to issuing a command.

For proper hexadecimal conversion of rate percentage, please refer to the Rate and Temperature Conversions section of this manual.

8 Unit Operation - KB, KH, WH, OK, AW, WA, OA, FTXL, Shield, & AQUAS Models *(continued)*

Control Mode 4 (DHW)

Domestic Hot Water Generation (DHW) can be accomplished with one of two methods when a boiler/water heater is connected to a BAS system, DHW with direct control, and DHW with remote control.

DHW with direct control:

This is a typical installation with a hot water generator in close proximity to the boiler/water heater with the tank thermostat or the tank temperature sensor wired to the terminal strip of the unit.

DHW with remote control:

This installation may have the hot water generator in close proximity to the boiler/water heater. Its sensors or thermostat values are only available through the ModBus / BACnet communication bus.

Control Mode 4 - Set-up

1. Enter the installer code - 5309.
2. While in the Control's Installer Main Menu, scroll to and select [CONTROL MODES].
3. In Control Modes Menu select [BMS TSTAT] and set to [ACTIVE] (see FIG. 8-6).
4. Perform Step 2 to set BMS TSTAT, and BMS reference FIG. 8-6.
5. Press the RIGHT SELECT [SAVE] key (see FIG. 8-6) to save all of the above parameter settings.

Figure 8-6_Control Modes Menu - Control Mode 4 - Set-up

```

SHUTDOWN
CONT SENSOR: OUT/SYS
BMS TSTAT      ACTIVE
BMS            ACTIVE
MODBUS        ACTIVE
EXIT  %ADJUST  SAVE
  
```

To ensure that the boiler/water heater can properly respond to a call for hot water generation the following holding registers must be set in addition to other commands:

Object	Holding Registers	Definition	Bit Value (HEX)	Action
AV0	40001	Configuration	00 4A	Set Configuration to read 40002, 4 & 5
AV1	40002	Coils / BV	00 08	Enables Tank Tstat (00 00 disables unit)
AV3	40004	Tank Set Point	0# ##	Sets Set Point
AV4	40005	Tank Temperature	0# ##	Passes tank temp from remote sensor

NOTE: To ensure proper operation re-send the configuration bits to holding register 40001 or Object AV0 prior to issuing a command.

For proper hexadecimal conversion of rate percentage, please refer to the Rate and Temperature Conversions section of this manual.

8 Unit Operation - KB, KH, WH, OK, AW, WA, OA, FTXL, Shield, & AQUAS Models

Cascade

In order to operate the boiler/water heater in Cascade with ModBus or BACnet communications, configure the Leader unit per the control modes in this manual. Connect the remaining boilers/water heaters in the Cascade through the normal daisy chain Cascade communications wiring. Cascade control can then be accomplished automatically through the Leader boiler.

Please note that with ModBus or BACnet communication connected to only the Leader unit, only total Cascade information can be seen through the communications link. If you wish to see all the individual temperatures of each unit in the Cascade, each unit will have to have a ModBus / BACnet communication board. However, each unit can be monitored without the need to control each one individually.

Monitoring Only

Any boiler/water heater can be equipped with the communication board and then set up to operate with its own internal controls. By default settings, the communication board is a ready monitoring device for the read only variables by polling the board.

Rate and Temperature Conversions:

Rate

When issuing a rate command the rate can be communicated as percent modulation or a desired set point, depending on the setting of the BMS Type in the BMS Setup Menu.

The proper data format for the modulation percentage is the direct conversion to hexadecimal. This conversion can be accomplished through online number based converters or some scientific calculators.

For Example:

Rate %	HEX
0	00
20	14
45	2D
60	3C
80	50
95	5F
100	64

To send a desired setpoint, the hexadecimal value must be determined through linear interpolation of programmable parameters on the BMS Setup Menu:

- BMS temperature set point at low analog input
- BMS temperature set point at high analog input

These variables set the temperature values corresponding to the minimum and maximum voltage settings of the 0-10 volt signal. The defaults are as follows:

PARAMETER	DEFAULT VALUES		DEFAULT
	Deg C	Deg F	Voltages
BMS temperature set point at low analog input	21	70	2
BMS temperature set point at high analog input	82	180	10

For Example:

Send a set point of 110°F.

The formula to use for the interpolation is:

Rate Command =

$$\frac{(\text{Desired Set point} - \text{BMS Temp at Low Analog Input}) (\text{High Voltage} - \text{Low Voltage})}{(\text{BMS Temp at High Analog Input} - \text{BMS Temp at Low Analog Input})} + \text{Low Voltage}$$

From the default values:

Desired Setpoint = 110

BMS Temp at Low Analog Input = 68

BMS Temp at High Analog = 158

High Voltage = 10

Low Voltage = 2

$$[(110 - 68)(10 - 2)] / (158 - 68) + 2 = 5.73 \text{ Volts}$$

5.73 Volts = 57.3% Modulation

57% = 39 Hexadecimal

A value of [00][39] in hexadecimal would be written to Holding register 40003 to issue a command for a 110°F setpoint.

Temperature

The boiler/water heater passes temperature data in degrees Celsius. Also, to accommodate decimal places the decimal value must be divided by 10.

Here are the conversions to and from Celsius:

$$T_c = (5/9) * (T_f - 32) \quad T_f = (9/5) * T_c + 32$$

Example:

Outdoor temperature from remote sensor on BAS System = 80°F

$$80^\circ\text{F} = 26.7^\circ\text{C}$$

Data that needs to be transmitted is $26.7 * 10 = 267$

Decimal	Binary	HEX
267	100001011	10B

Outlet temperature from unit sensor = 155°F

$$155^\circ\text{F} = 68.3^\circ\text{C}$$

Data transmitted from unit in HEX = 2AB = 683

$$683 \div 10 = 68.3 \text{ (}^\circ\text{C)}$$

Decimal	Binary	HEX
683	1010101011	2AB

8 Unit Operation - AWH & KBX Models *(continued)*

Unit Operation with ModBus / BACnet Communications

To control an AWH or KBX appliance through a Building Management System communicating through ModBus or BACnet, the AWH or KBX Demand Configuration must be set to one of three options. These configurations allow different control points for a variety of applications. The configuration can be set by selecting Main Menu>>Setup>>BMS.

The AWH or KBX appliance is equipped with a ModBus communication timer. This timer is programmable from 0 - 120 seconds. The timer can be programmed from the ModBus Setup Menu by selecting Main Menu>>Setup>>ModBus. The purpose of the timer is to ensure proper temperature data is communicated to the boiler in a timely manner. Additionally, it will provide for fail safe operation should ModBus communication be lost. This timer will cause the unit to revert back to internal unit controls should the ModBus communication be interrupted longer than the ModBus timer. The timer is reset every time a ModBus write command is received with updated temperatures or commands. It is the recommendation of Lochinvar that this timer be set to the shortest value possible.

When controlling an AWH or KBX appliance through a Building Automation System (BAS), it is very important to ensure that the correct configuration bits are sent to holding register 40001 or Object AV0, and that the correct data and enable signals are sent to holding registers 40002 - 40007 or Objects AV1 - AV6, per the demand configuration.

Demand Configuration: ENABLE = ACTIVE; BMS = INACTIVE

In this configuration the unit is controlled by setting the setpoints locally on the appliance and providing an enable signal through ModBus or BACnet communications.

All sensors and limiting devices should be hardwired to the terminal strip on the back of the unit excluding the enable signal. This signal will be sent to the unit via ModBus.

The holding registers will need to be set as follows:

Object	Holding Registers	Definition	Bit Value (HEX)	Action
AV0	40001	Configuration	00 01	Set Configuration to read 40002
AV1	40002	Coils	00 01	Enables unit (00 00 disables unit)

NOTE: To ensure proper operation re-send the configuration bits to holding register 40001 or Object AV0 prior to issuing a command.

8 Unit Operation - AWH & KBX Models

Demand Configuration: ENABLE = ACTIVE; BMS = ACTIVE

In this configuration the unit is controlled by providing an enable signal. The setpoint command will be determined by the parameters in the control and a rate command through ModBus or BACnet communications.

The rate command will be 0 - 100% of modulation.

All sensors and limiting devices should be hardwired to the terminal strip on the back of the unit excluding the enable and 0-10V BMS signal. These signals will be sent to the unit via ModBus or BACnet.

The holding registers will need to be set as follows:

Object	Holding Registers	Definition	Bit Value (HEX)	Action
AV0	40001	Configuration	00 05	Set Configuration to read 40002 & 3
AV1	40002	Coils	00 01	Enables unit (00 00 disables unit)
AV2	40003	Rate Command	00 ##	Sets Modulation % or Setpoint

NOTE: To ensure proper operation re-send the configuration bits to holding register 40001 or Object AV0 prior to issuing a command.

For proper hexadecimal conversion of rate percentage, please refer to the Rate and Temperature Conversion section of this manual.

Demand Configuration: ENABLE = INACTIVE; BMS = ACTIVE

In this configuration the unit is controlled by setting the modulation setpoint from 0 - 100%, or the setpoint. The setpoint command will be determined by the parameters in the control.

Rate command will be 0 - 100% of the modulation range.

All sensors and limiting devices should be hardwired to the terminal strip on the back of the unit excluding the 0 - 10Vdc signal. This signal will be sent to the unit via ModBus or BACnet.

The holding registers will need to be set as follows:

Object	Holding Registers	Definition	Bit Value (HEX)	Action
AV0	40001	Configuration	00 04	Set Configuration to read 40003
AV1	40003	Rate Command	00 00	Sets Modulation % or Setpoint

NOTE: To ensure proper operation re-send the configuration bits to holding register 40001 or Object AV0 prior to issuing a command.

For proper hexadecimal conversion of rate percentage, please refer to the Rate and Temperature Conversion section of this manual.

Hot Water Generation

Hot water generation can be accomplished with one of two methods when an AWH or KBX appliance is connected to a BAS system, DHW with direct control, and DHW with remote control.

DHW with direct control:

This is the typical installation with a hot water generator in close proximity to the boiler with the tank thermostat, or tank temperature sensor, wired to the terminal strip of the unit.

8 Unit Operation - AWH & KBX Models *(continued)*

DHW with remote control:

This installation may or may not have the hot water generator in close proximity to the appliance. Its sensors and thermostat values are only available through the ModBus or BACnet communication bus.

To ensure that the appliance can properly respond to a call for hot water generation the following holding registers must be set in addition to other commands:

Object	Holding Registers	Definition	Bit Value (HEX)	Action
AV0	40001	Configuration	00 4A	Set Configuration to read 40002, 4 & 5
AV1	40002	Coils	00 08	Enables Tank Tstat (00 00 disables unit)
AV3	40004	Tank Setpoint	0# ##	Sets Setpoint
AV4	40005	Tank Temperature	0# ##	Passes tank temp from remote sensor

NOTE: To ensure proper operation re-send the configuration bits to holding register 40001 or Object AV0 prior to issuing a command.

For proper hexadecimal conversion of rate percentage, please refer to the Rate and Temperature Conversion section of this manual.

Cascade

In order to operate the appliance in Cascade with ModBus / BACnet communications, configure the leader appliance per the demand configurations in this manual. Connect the remaining appliances in the cascade through the normal cascade communications wiring. Cascade control can then be accomplished automatically through the leader appliance.

Please note that with ModBus / BACnet communication connected to only the leader appliance, total Cascade information can be seen through the communications link. If you wish to see all the individual temperatures of each unit in the Cascade, each unit will have to have a communication board. However, each unit can be monitored without the need to control each one individually.

Monitoring Only

All AWH and KBX appliances are equipped with the communication board and can be set up to operate with its own internal controls. If necessary, ModBus / BACnet can be configured as a monitoring device by polling the communication board for the read only variables.

8 Unit Operation - AWH & KBX Models

Rate and Temperature Conversions:

Rate

When issuing a rate command the rate can be communicated as percent modulation or a desired setpoint, depending on the setting of the BMS Type in the BMS Setup Menu.

The proper data format for the modulation percentage is the direct conversion to hexadecimal. This conversion can be accomplished through online number based converters or some scientific calculators.

For Example:

Rate %	HEX
0	00
20	14
45	2D
60	3C
80	50
95	5F
100	64

To send a desired setpoint, the hexadecimal value must be determined through linear interpolation of programmable parameters on the BMS Setup Menu:

- BMS temperature set-point at low analog input
- BMS temperature set-point at high analog input

These variables set the temperature values corresponding to the minimum and maximum voltage settings of the 0-10 volt signal. The defaults are as follows:

PARAMETER	DEFAULT VALUES		DEFAULT
	Deg C	Deg F	Voltages
BMS temperature setpoint at low analog input	21	69.8	2
BMS temperature setpoint at high analog input	82	179.6	10

For Example:

Send a setpoint of 110°F.

The formula to use for the interpolation is:

Rate Command =

$$\frac{(\text{Desired Setpoint} - \text{BMS Temp at Low Analog Input}) (\text{High Voltage} - \text{Low Voltage})}{\text{BMS Temp at High Analog Input} - \text{BMS Temp at Low Analog Input}} + \text{Low Voltage}$$

$$\frac{(110 - 69.8)(10 - 2)}{179.6 - 69.8} + 2 = 4.92 \text{ Volts}$$

From the default values:

Desired Setpoint = 110

BMS Temp at Low Analog Input = 68

BMS Temp at High Analog = 158

High Voltage = 10

Low Voltage = 2

$$\frac{(110 - 69.8)(10 - 2)}{(179.6 - 69.8)} + 2 = 4.92 \text{ Volts}$$

$$(4.92 / 10) \times 100 = 49.2$$

$$49 = 31 \text{ Hexadecimal}$$

A value of [00][31] in hexadecimal would be written to Holding register 40003 to issue a command for a 110°F setpoint.

Temperature

The appliance passes temperature data in degrees Celsius. Also, to accommodate decimal places the decimal value must be divided by 10.

Here are the conversions to and from Celsius:

$$T_c = (5/9) * (T_f - 32) \quad T_f = (9/5) * T_c + 32$$

Example:

Outdoor temperature from remote sensor on BAS System = 80°F

$$80^\circ\text{F} = 26.7^\circ\text{C}$$

Data that needs to be transmitted is $26.7 * 10 = 267$

Decimal	Binary	HEX
267	100001011	10B

Outlet temperature from unit sensor = 155°F

$$155^\circ\text{F} = 68.3^\circ\text{C}$$

Data transmitted from unit in HEX = 2AB = 683

$$683 \div 10 = 68.3 \text{ (}^\circ\text{C)}$$

Decimal	Binary	HEX
683	1010101011	2AB

9 Troubleshooting

Should you encounter problems communicating over ModBus, the following items should be checked in this order:

1. Physical Layer
2. Communications Configuration and Port Settings
3. ModBus Error Codes
4. Unit Status / Blocking / Lockout Codes

Physical Layer

1. Check that all components have power (Boiler, Gateway, BAS Master)
2. Check all wire lengths. Are any drops too long?
3. Check proper shield grounding
4. Check A, B terminal connections
5. Check for Terminating Resistors (120 ohms)
6. Check for broken wires

Communications

1. Check Dip Switch Configuration of Communication Board
2. Check Baud Rate (9600, 19200, etc.)
3. Check Parity (ModBus only)
4. Check Slave ID
5. Check Port Setting on Master, Gateway, and Computers

ModBus Error Codes

1. Check ModBus communication for error codes (see page 12 for ModBus Exception Codes)
2. Check ModBus PDU
3. Check Slave ID
4. Check ModBus Command
5. Check Configuration bits for Holding Register 40001
6. Check Commands and data for Holding Registers 40002 - 40007

Unit Status Codes

See Codes in this section.

Boiler Status

The boiler/water heater status code indicates what the unit is actually doing. This status code should be compared to the command issued and what is expected. If the boiler/water heater status code does not agree with the command issued, check communication and configuration.

Status Codes (Input Register 30014 or Analog Input AI13)

- 2 = Heat Demand blocked due to high absolute outlet temperature
- 3 = Heat Demand blocked due to high absolute flue temperature
- 4 = Heat Demand blocked due to high absolute Delta T (Outlet - Inlet)
- 8 = Heat Demand blocked due to Low 24 VAC
- 9 = Outdoor shutdown
- 10 = Block due to switch OFF boiler (ON/OFF of Display)
- 12 = Block due to no correct communication Cascade
- 16 = Service function
- 19 = DHW function Storage Tank
- 21 = SH function Heat demand from Room Thermostat
- 22 = SH function Heat demand from Boiler Management System
- 23 = SH function Heat demand from Cascade
- 30 = Heat demand activated by Freeze Protection
- 32 = DHW Pump Delay
- 33 = SH Pump Delay
- 34 = No heat function (after pump delay)
- 40 = Lockout
- 32764 = Busy with updating status
- 32765 = DHW blocked due to no present tank sensor
- 32766 = Burner control(s) manually shut down
- 32767 = Code not present

Blocking Codes (Input Register 30015 or AI14)

- 0 = No blocking _> is divided into sub blockings
- 1 = SH blocking
- 2 = Blocking Due to Low 24 VAC Supply
- 3 = Blocking due to General block
- 4 = Blocking MRHL is open
- 5 = Blocking due to Switched OFF boiler (Display ENTER switch)
- 6 = Blocking due to wrong communication of Cascade
- 7 = Blocking due to High Delta
- 8 = Blocking due to High Flue Temperature
- 9 = Blocking due to High Outlet Temperature
- 10 = Service blocking
- 12 = DHW blocking high outlet temperature (DHW configured as storage tank)
- 13 = Blocking anti-cycling time
- 14 = Storage Tank demand Blocked due to Fan problems
- 15 = No system sensor connected and leader control present
- 16 = Limit fan speed due to high outlet temperature
- 17 = Fan min decreased due to low flame current
- 18 = Limit max fan speed due to high Delta T
- 19 = Limit max fan speed due to high flue temp
- 32767 = Code not present

9 Troubleshooting

Lockout Codes (Input Register 30016 or AI15)

NOTICE

The lockout code is constantly changing during operation and should not be used for lockout notification until the status code (Input Register 30014 or AI13) indicates a code of 40.

- 161 = EEPROM code Parameters not Re-Programmed by Lochinvar
- 164 = EEPROM code No Reset Allowed (> 15 minutes)
- 166 = EEPROM code Auto Reset High Limit
- 167 = EEPROM code Blocked Drain
- 168 = EEPROM code Louver Proving
- 169 = EEPROM code Gas Pressure Sw
- 170 = EEPROM code Flow Switch
- 177 = Sensor 3 short (Flue Sensor)
- 178 = Sensor 3 open (Flue Sensor)
- 179 = Sensor 2 short (Inlet Sensor)
- 180 = Sensor 2 open (Inlet Sensor)
- 192 = Sensor 1 short (Outlet Sensor)
- 193 = Sensor 1 open (Outlet Sensor)
- 204 = CRC EEPROM failed
- 205 = EEPROM programmed (display shows "PP")
- 206 = EEPROM error in programming
- 207 = Write error EEPROM
- 229 = EEPROM code Watch Dog
- 230 = EEPROM code fan low (should be high)
- 231 = EEPROM code fan high (should be low)
- 232 = EEPROM code no flame when running
- 233 = EEPROM code no flame after ignition
- 234 = EEPROM code simultaneous output APS and Fan
- 235 = EEPROM code APS active not Closed
- 236 = EEPROM code APS active not Open
- 237 = EEPROM code flame out of sequence
- 239 = EEPROM code when gas valve relay test fails
- 240 = EEPROM code MRHL
- 32767 = Code not present

10 Diagrams

Figure 10-1 Ladder Diagram_Knight/Knight Wall Mount

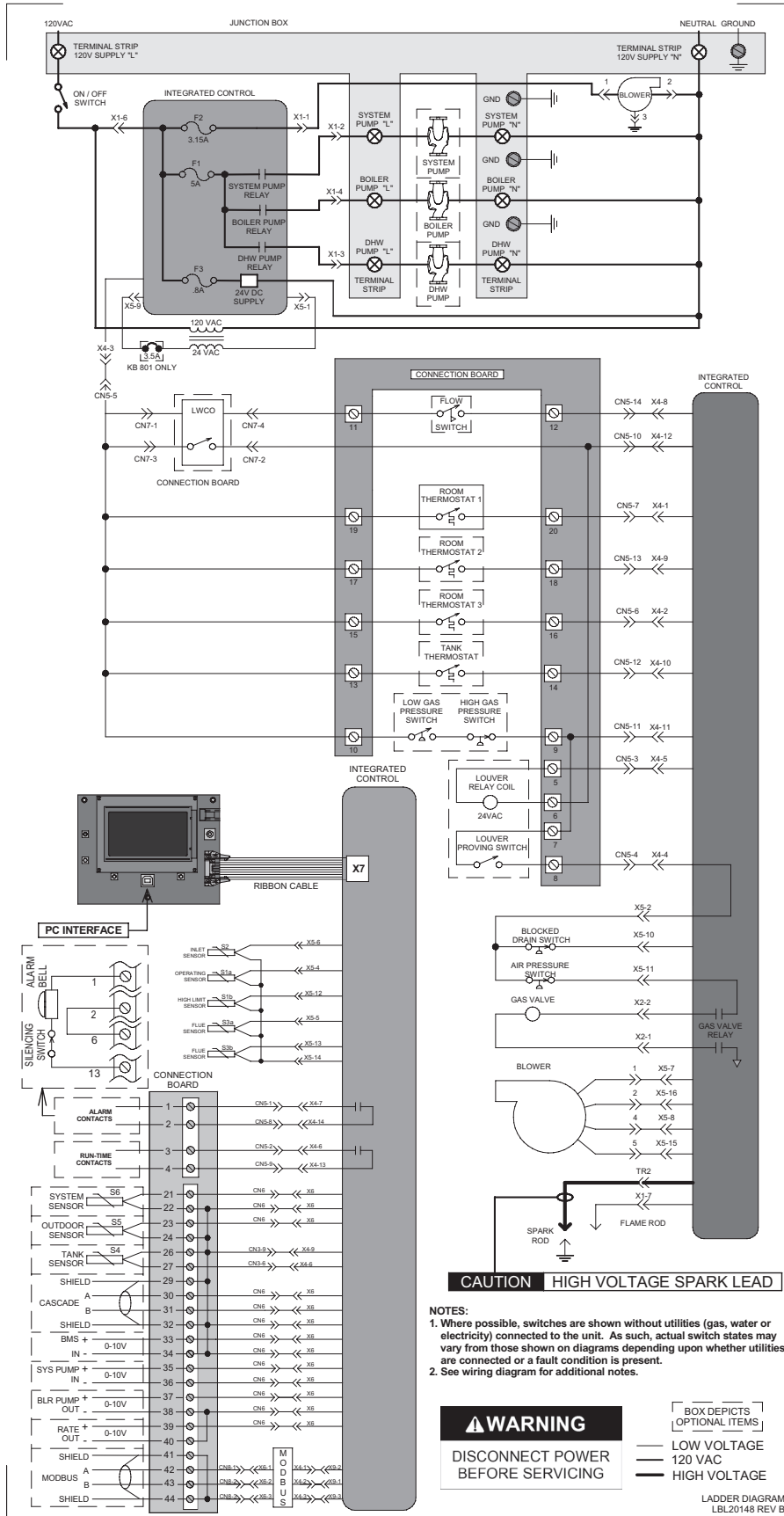

10 Diagrams

Figure 10-2 Wiring Diagram_Knight/Knight Wall Mount

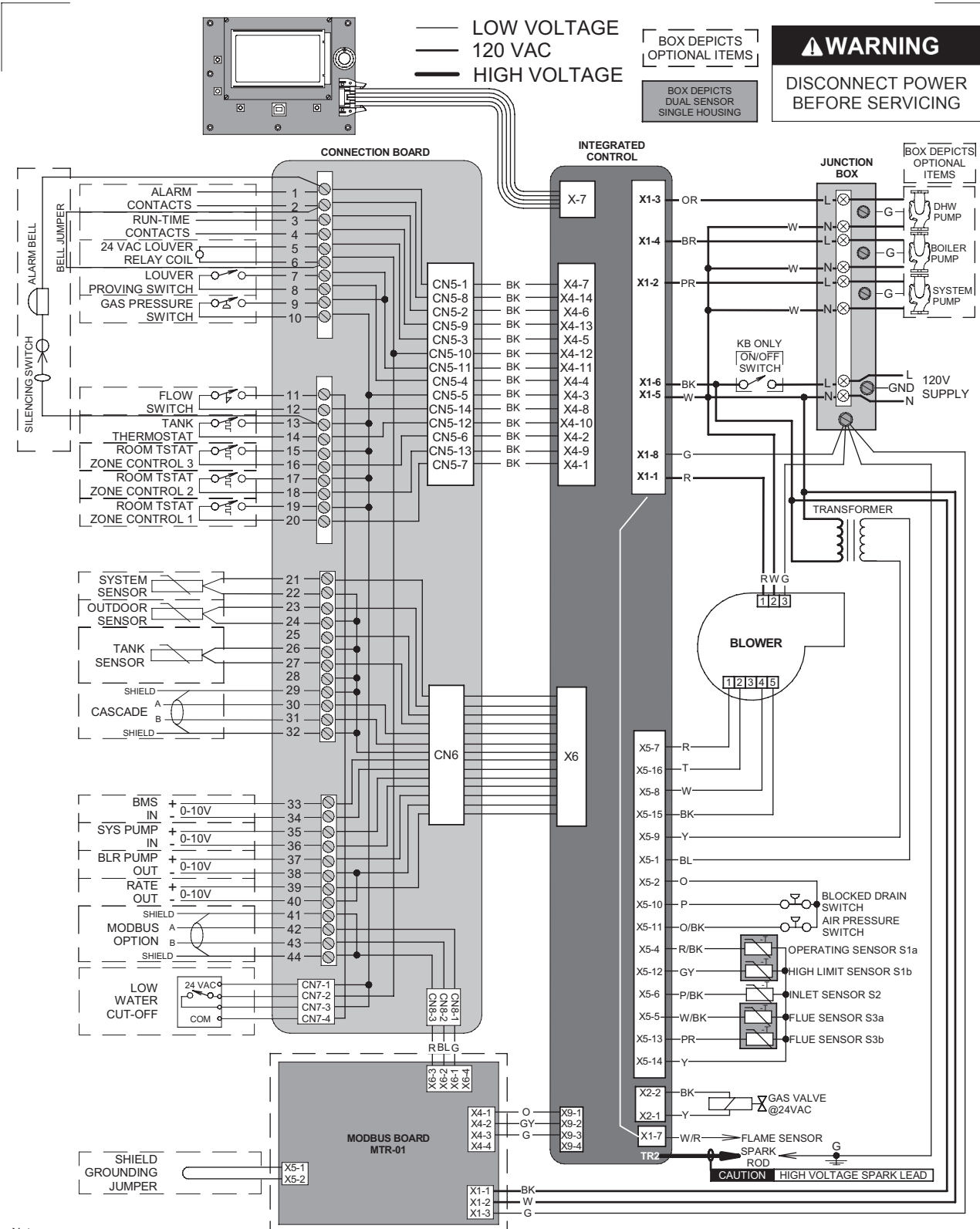

- Notes:
1. All wiring must be installed in accordance with: local, state, provincial and national code requirements per either N.E.C. in USA or C.S.A. in Canada.
 2. If any original equipment wire as supplied with the appliance must be replaced, it must be replaced with wire having same wire gauge (AWG) and rated for a minimum of 105°C. Exceptions: Replacement high voltage spark lead and ribbon cables must be purchased from the factory. Use of a non-approved spark lead or ribbon cables can lead to operational problems which could result in non-repairable damage to the integrated controller or other components.
 3. Actual connector block locations may vary from those shown on diagrams. Refer to actual components for proper connector block locations when using diagrams to troubleshoot unit.

10 Diagrams *(continued)*

Figure 10-3 Ladder Diagram_Knight XL

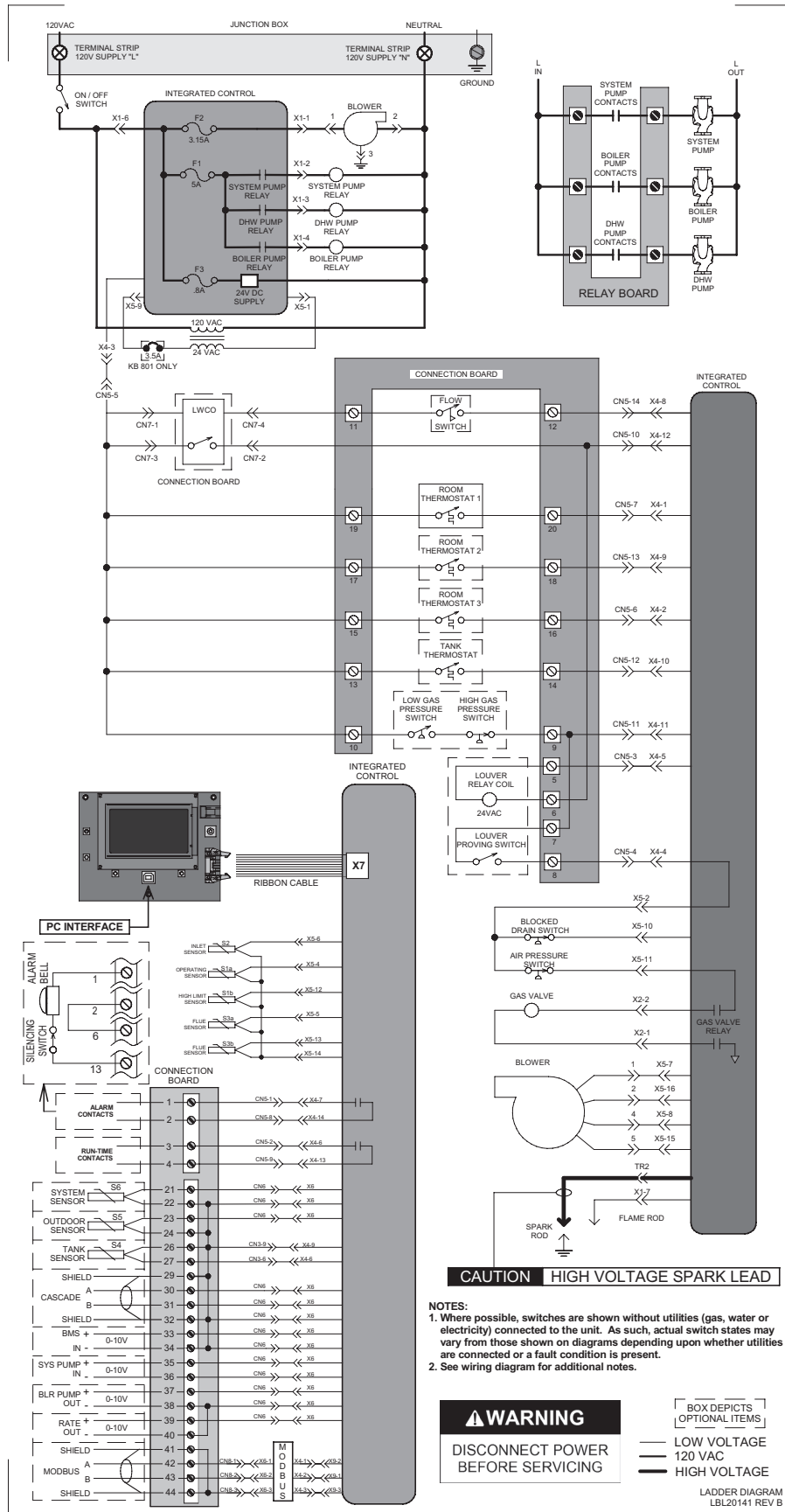

NOTES:
 1. Where possible, switches are shown without utilities (gas, water or electricity) connected to the unit. As such, actual switch states may vary from those shown on diagrams depending upon whether utilities are connected or a fault condition is present.
 2. See wiring diagram for additional notes.

⚠ WARNING
 DISCONNECT POWER BEFORE SERVICING

BOX DEPICTS OPTIONAL ITEMS
 — LOW VOLTAGE
 — 120 VAC
 — HIGH VOLTAGE

LADDER DIAGRAM
 LBL20141 REV B

10 Diagrams

Figure 10-4 Wiring Diagram_Knight XL

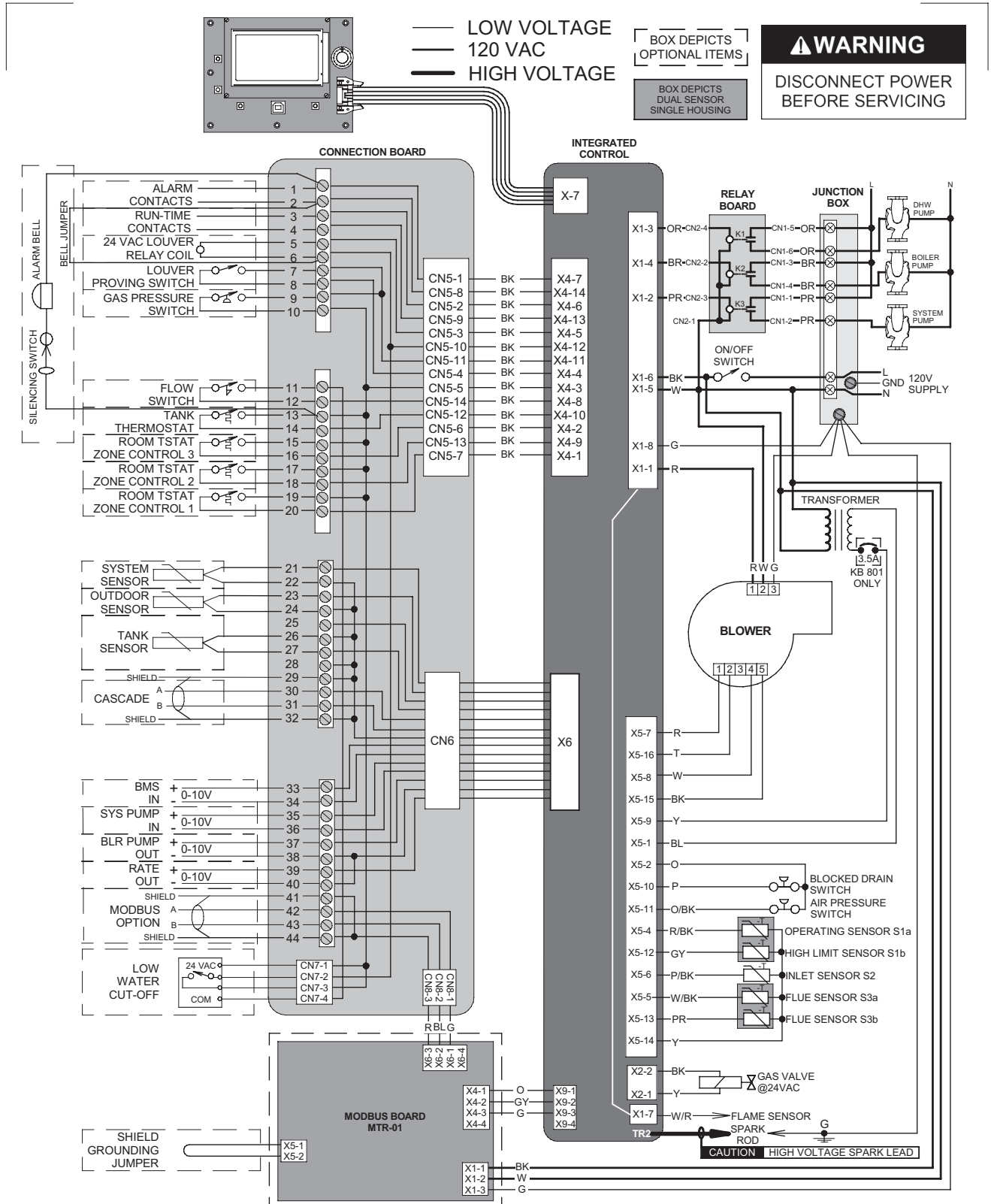

- Notes:
1. All wiring must be installed in accordance with: local, state, provincial and national code requirements per either N.E.C. in USA or C.S.A. in Canada.
 2. If any original equipment wire as supplied with the appliance must be replaced, it must be replaced with wire having same wire gauge (AWG) and rated for a minimum of 105°C. Exceptions: Replacement high voltage spark lead and ribbon cables must be purchased from the factory. Use of a non-approved spark lead or ribbon cables can lead to operational problems which could result in non-repairable damage to the integrated controller or other components.
 3. Actual connector block locations may vary from those shown on diagrams. Refer to actual components for proper connector block locations when using diagrams to troubleshoot unit.

10 Diagrams *(continued)*

Figure 10-5 Ladder Diagram_Armor / Armor Wall Mount

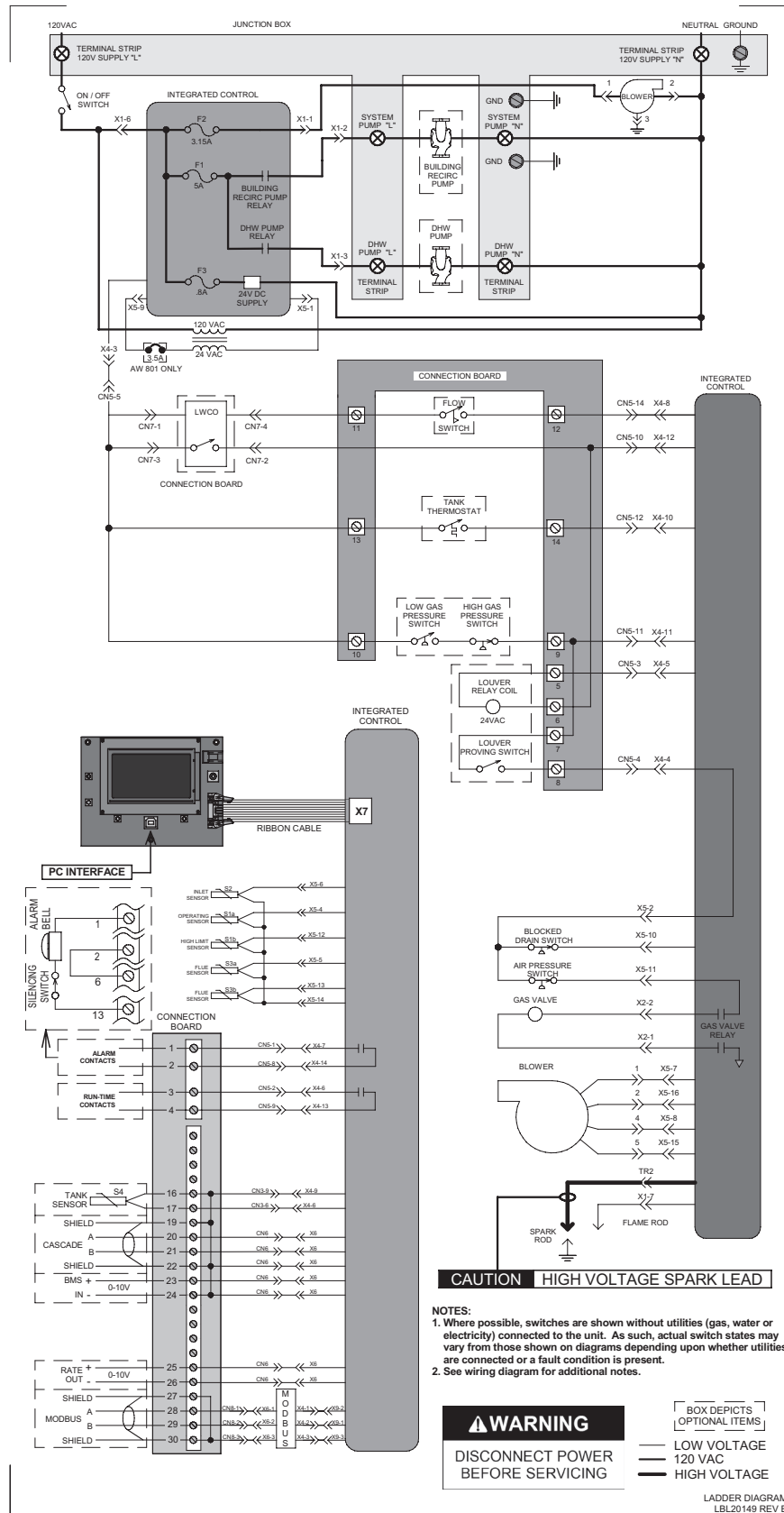

10 Diagrams

Figure 10-6 Wiring Diagram_Armor / Armor Wall Mount

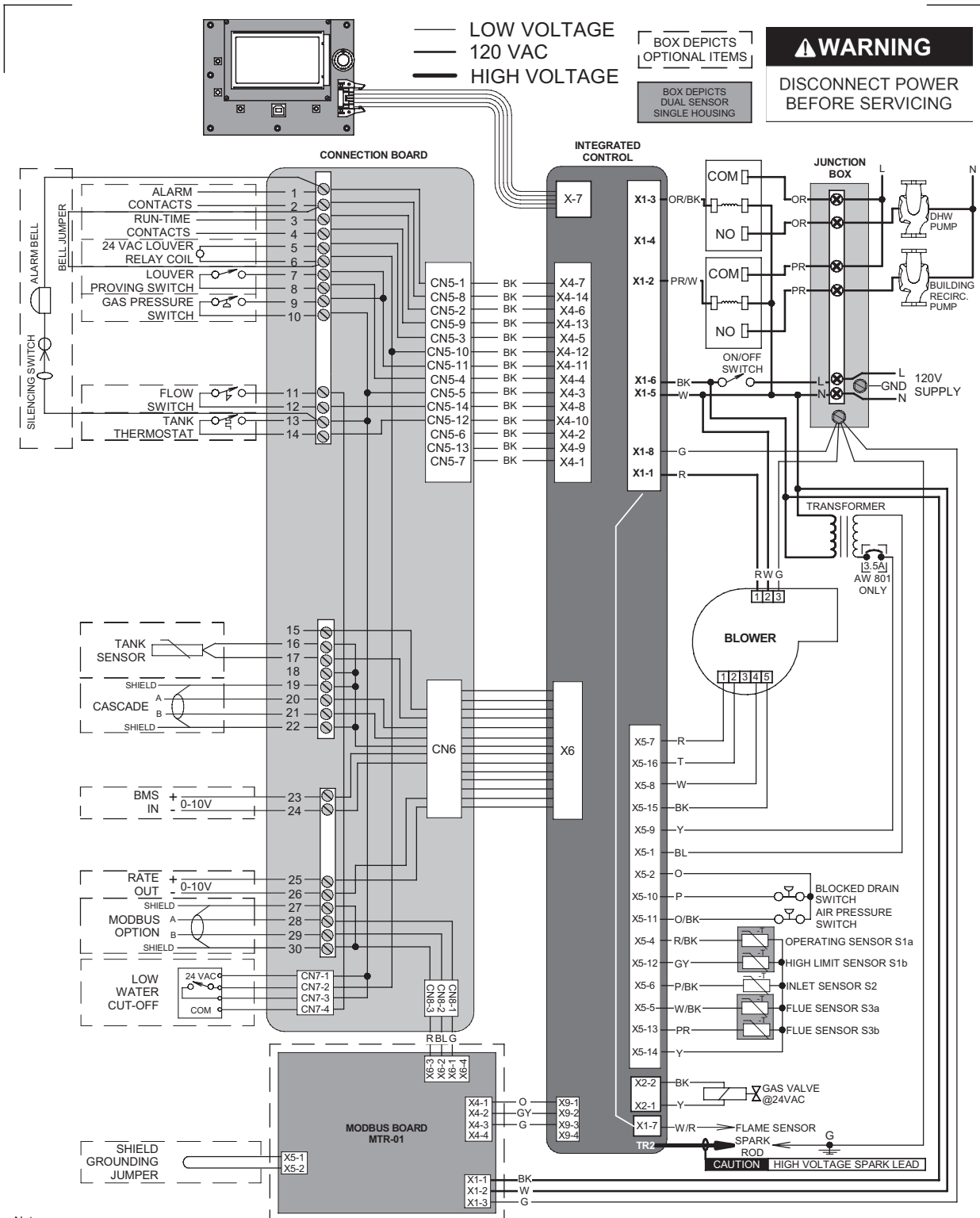

Notes:

1. All wiring must be installed in accordance with: local, state, provincial and national code requirements per either N.E.C. in USA or C.S.A. in Canada.
2. If any original equipment wire as supplied with the appliance must be replaced, it must be replaced with wire having same wire gauge (AWG) and rated for a minimum of 105°C. Exceptions: Replacement high voltage spark lead and ribbon cables must be purchased from the factory. Use of a non-approved spark lead or ribbon cables can lead to operational problems which could result in non-repairable damage to the integrated controller or other components.
3. Actual connector block locations may vary from those shown on diagrams. Refer to actual components for proper connector block locations when using diagrams to troubleshoot unit.

10 Diagrams *(continued)*

Figure 10-7 Ladder Diagram_Wall Hung

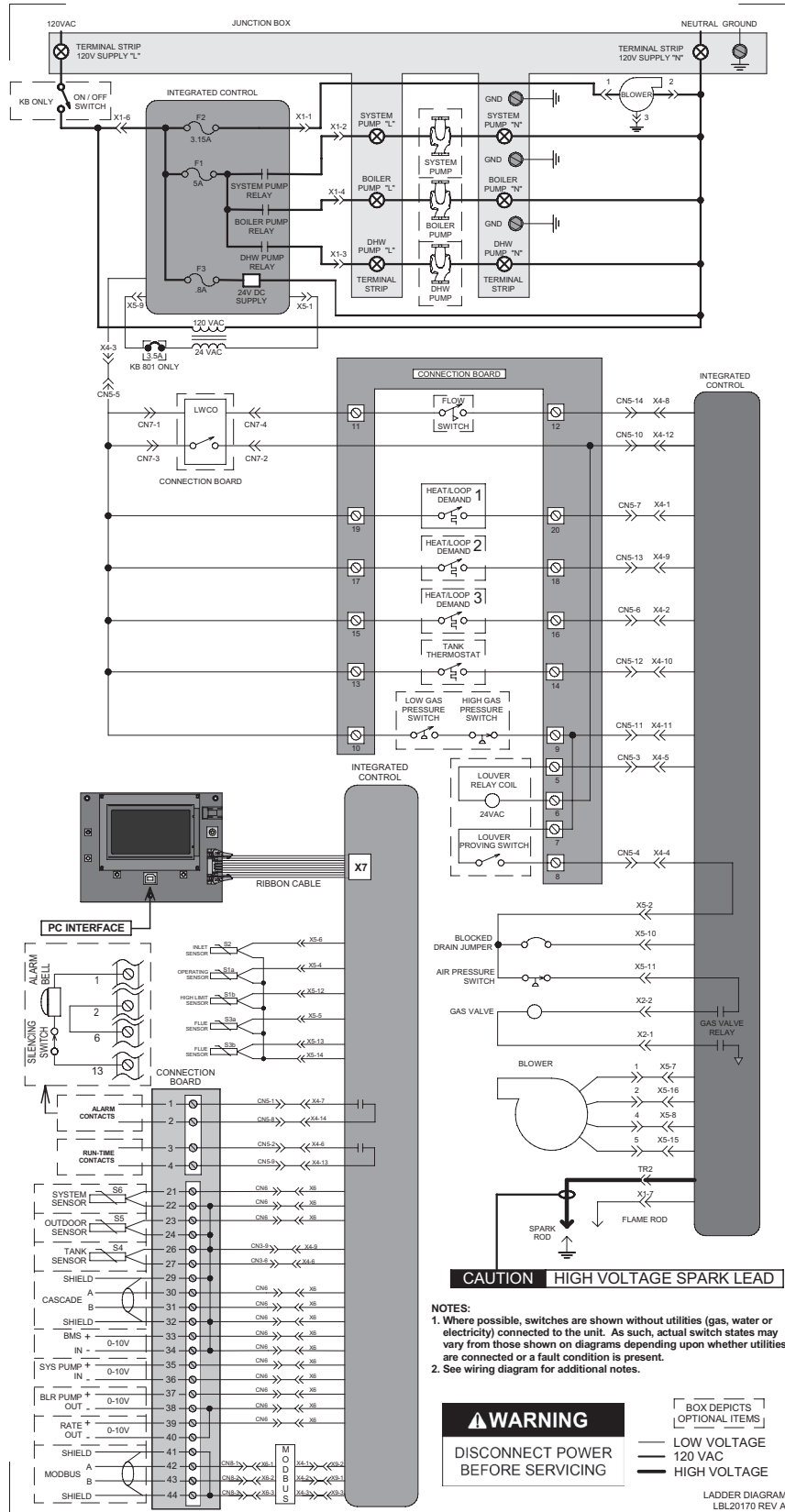

10 Diagrams

Figure 10-8 Wiring Diagram_Wall Hung

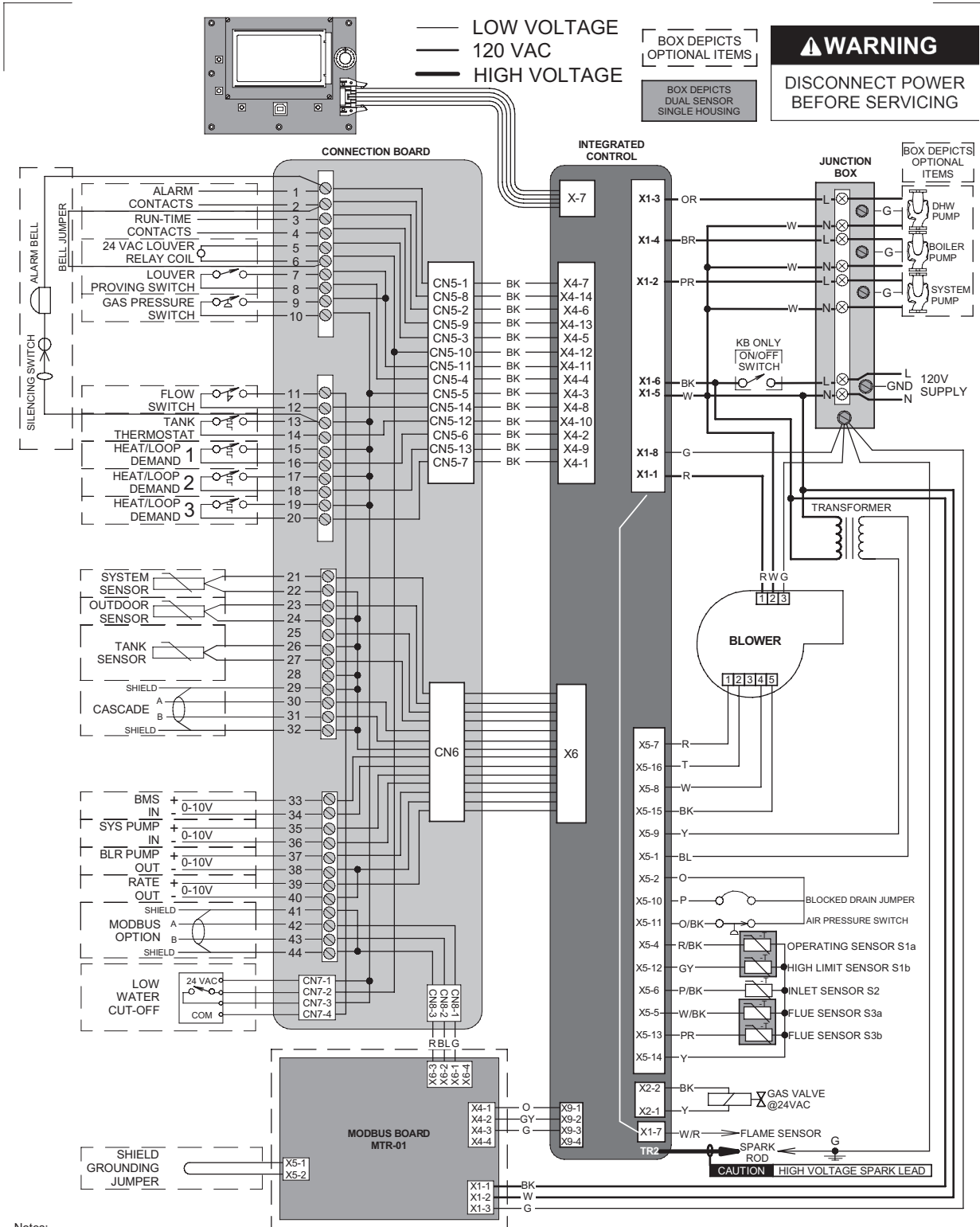

Notes:

1. All wiring must be installed in accordance with: local, state, provincial and national code requirements per either N.E.C. in USA or C.S.A. in Canada.
2. If any original equipment wire as supplied with the appliance must be replaced, it must be replaced with wire having same wire gauge (AWG) and rated for a minimum of 105°C. Exceptions: Replacement high voltage spark lead and ribbon cables must be purchased from the factory. Use of a non-approved spark lead or ribbon cables can lead to operational problems which could result in non-repairable damage to the integrated controller or other components.
3. Actual connector block locations may vary from those shown on diagrams. Refer to actual components for proper connector block locations when using diagrams to troubleshoot unit.

WIRING DIAGRAM
LBL20169 REV A

10 Diagrams *(continued)*

Figure 10-9 Ladder Diagram_FTXL

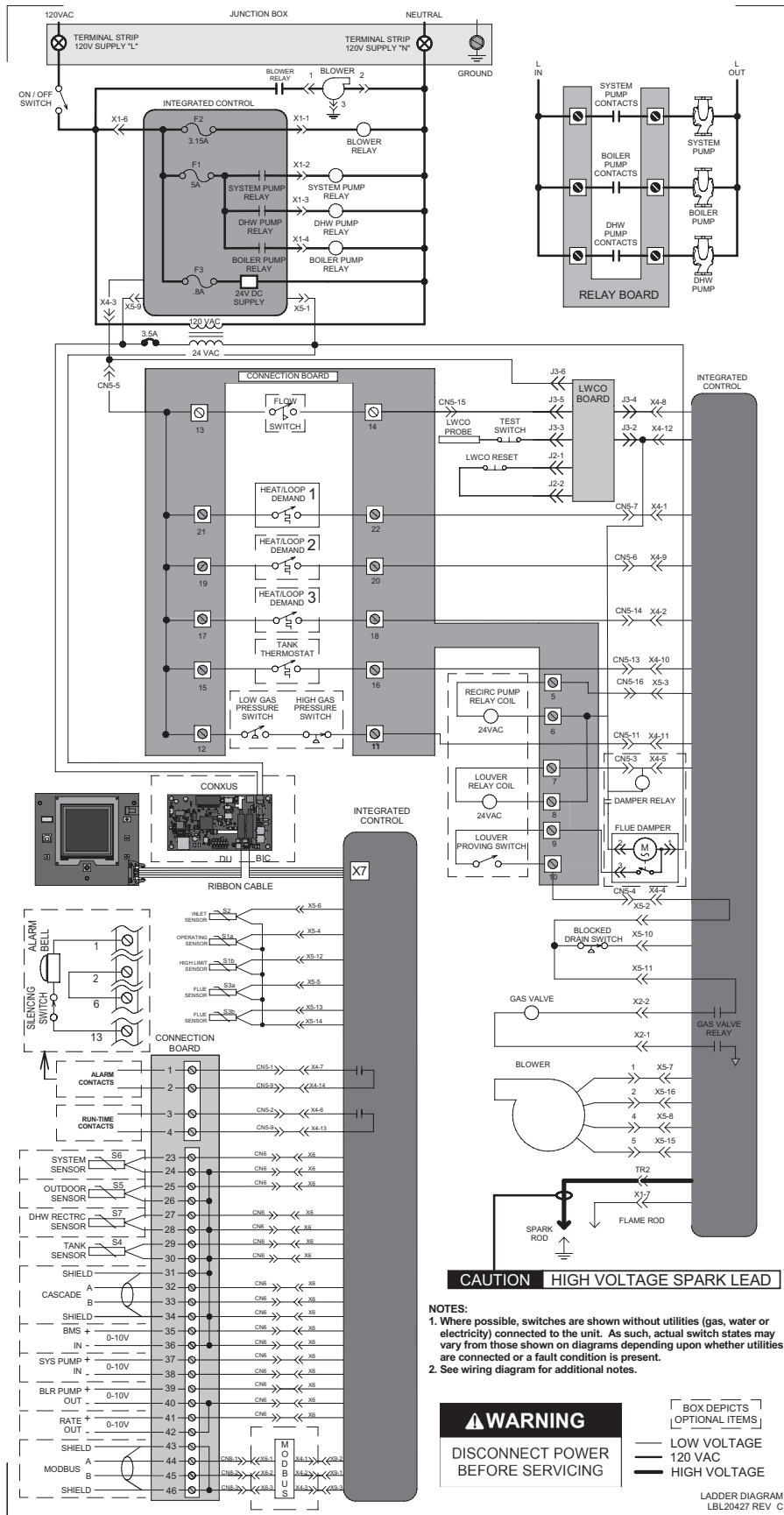

10 Diagrams

Figure 10-10 Wiring Diagram_FTXL

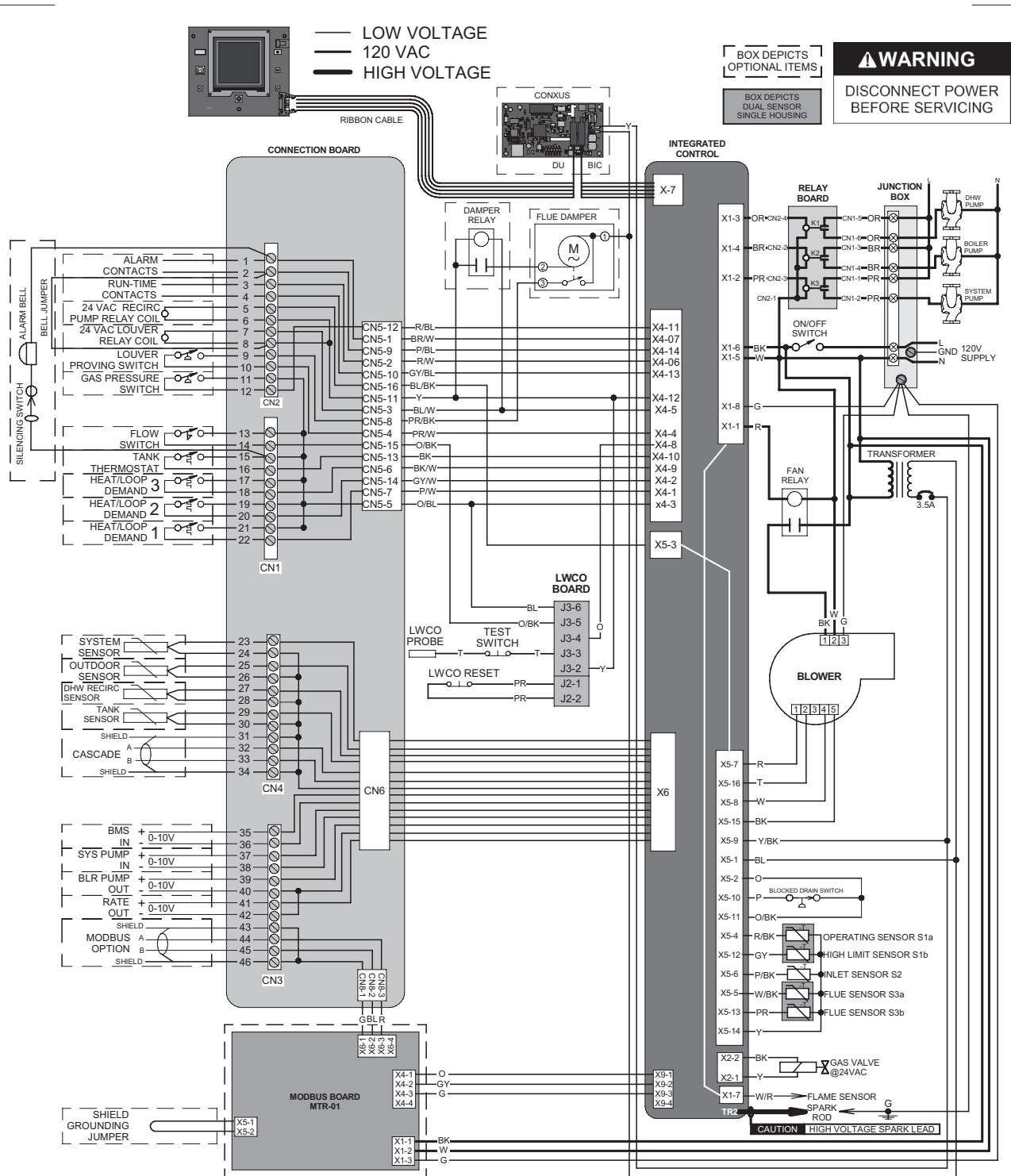

- Notes:
1. All wiring must be installed in accordance with: local, state, provincial and national code requirements per either N.E.C. in USA or C.S.A. in Canada.
 2. If any original equipment wire as supplied with the appliance must be replaced, it must be replaced with wire having same wire gauge (AWG) and rated for a minimum of 105°C. Exceptions: Replacement high voltage spark lead and ribbon cables must be purchased from the factory. Use of a non-approved spark lead or ribbon cables can lead to operational problems which could result in non-repairable damage to the integrated controller or other components.
 3. Actual connector block locations may vary from those shown on diagrams. Refer to actual components for proper connector block locations when using diagrams to troubleshoot unit.

WIRING DIAGRAM
 LBL20426 REV C

10 Diagrams *(continued)*

Figure 10-11 Ladder Diagram_Shield

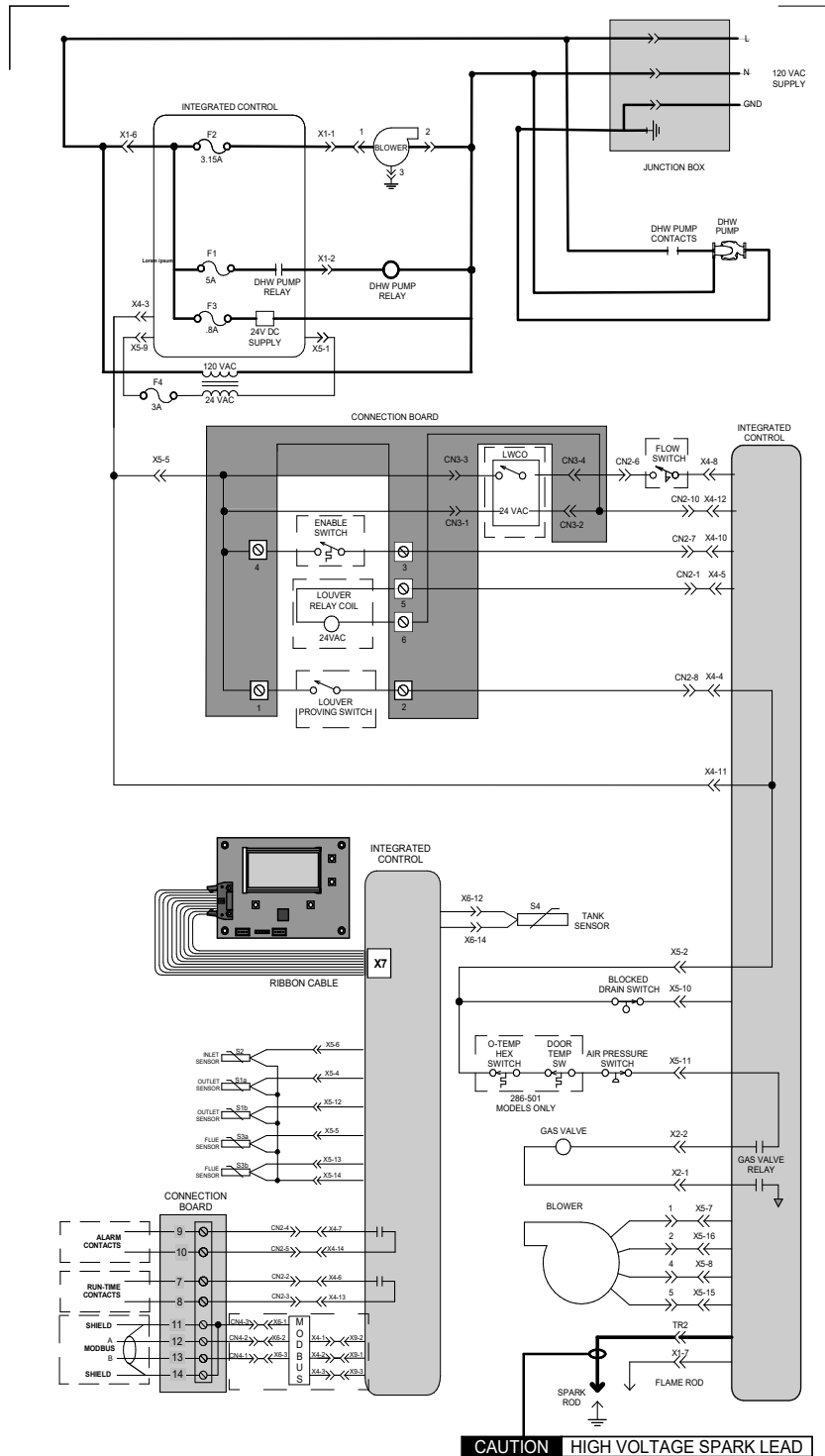

NOTES:
 1. Where possible, switches are shown without utilities (gas, water or electricity) connected to the unit. As such, actual switch states may vary from those shown on diagrams depending upon whether utilities are connected or a fault condition is present.
 2. See wiring diagram for additional notes.

⚠ WARNING

DISCONNECT POWER BEFORE SERVICING

BOX DEPICTS OPTIONAL ITEMS

— LOW VOLTAGE

— 120 VAC

— HIGH VOLTAGE

LADDER DIAGRAM
100328093 REV C

10 Diagrams *(continued)*

Figure 10-13 Ladder Diagram_AWH

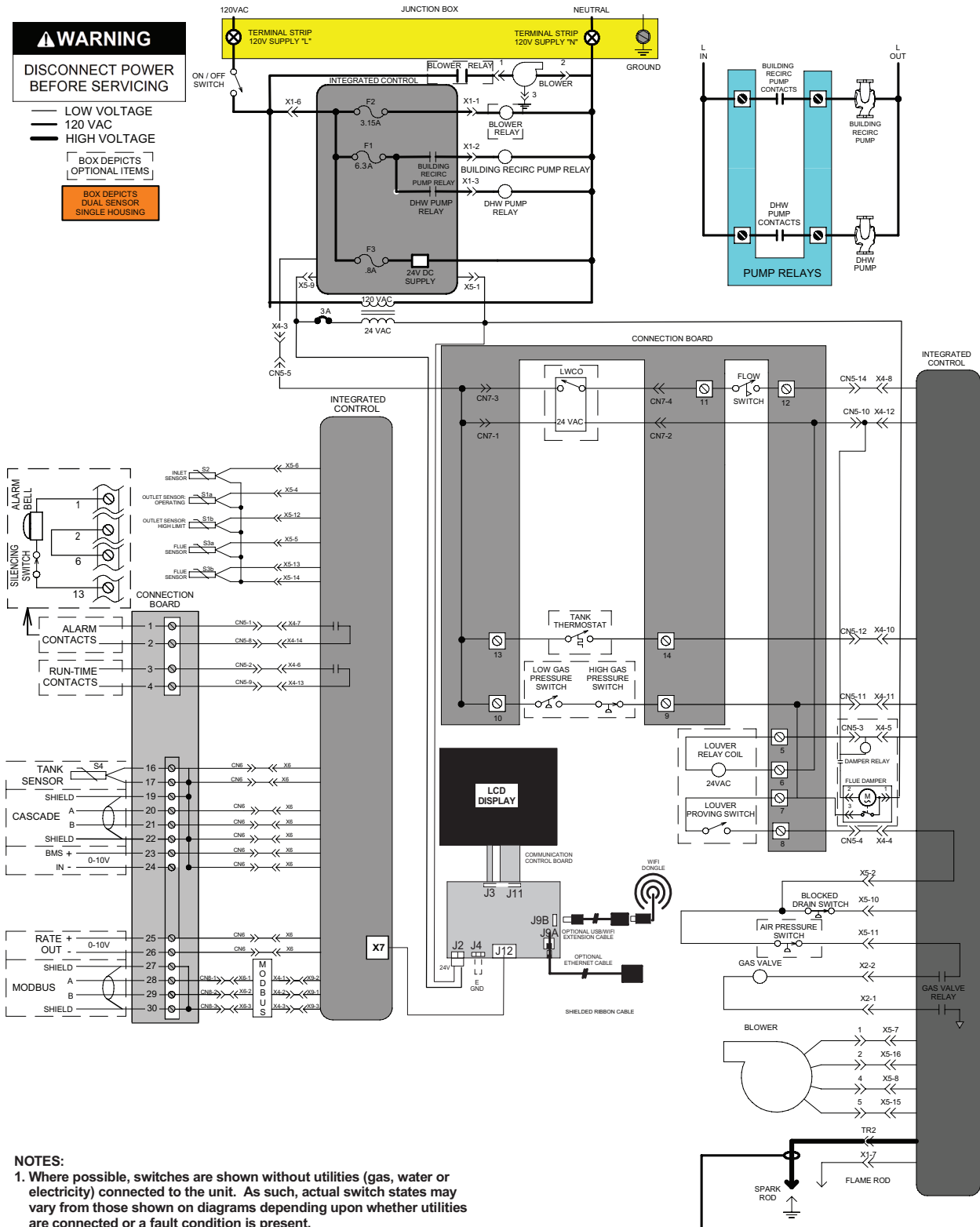

⚠ WARNING
DISCONNECT POWER BEFORE SERVICING

- LOW VOLTAGE
- 120 VAC
- HIGH VOLTAGE
- BOX DEPICTS OPTIONAL ITEMS
- BOX DEPICTS DUAL SENSOR SINGLE HOUSING

- NOTES:**
- Where possible, switches are shown without utilities (gas, water or electricity) connected to the unit. As such, actual switch states may vary from those shown on diagrams depending upon whether utilities are connected or a fault condition is present.
 - See wiring diagram for additional notes.

CAUTION HIGH VOLTAGE SPARK LEAD

100329774 REV B

10 Diagrams

Figure 10-14 Wiring Diagram_AWH

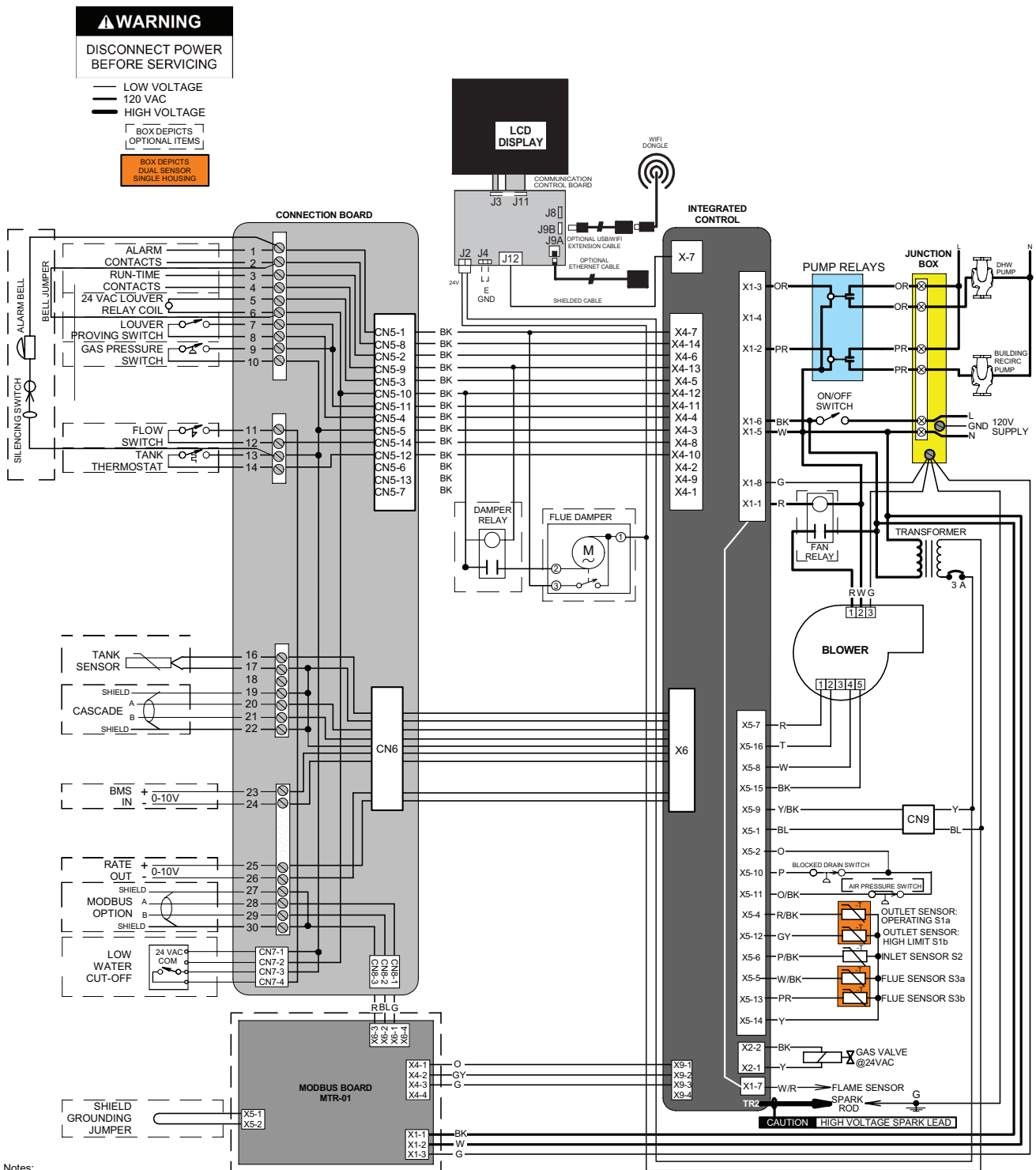

Notes:

1. All wiring must be installed with local, state, provincial, and national code requirements per either N.E.C. in USA or C.S.A. in Canada.
2. If any original equipment wire as supplied with appliance must be replaced, then it must be replaced with wire having same wire gauge (AWG) and rated for a minimum of 105°C. Exceptions: Replacement high voltage spark lead and ribbon cables must be purchased from the factory. Use of a non-approved spark lead or ribbon cables can lead to operational problems which could result in non-repairable damage to the integrated controller or other components.
3. Actual connector block locations may vary from those shown on diagrams. Refer to actual components for proper connector block locations when using diagrams to trouble shoot.
4. Where possible, switches are shown without utilities (gas, water, electricity) connected to the unit. As such, actual switch states may vary from those shown on diagrams depending upon whether utilities are connected or fault condition is present.

10 Diagrams

Figure 10-16 Wiring Diagram_KBX

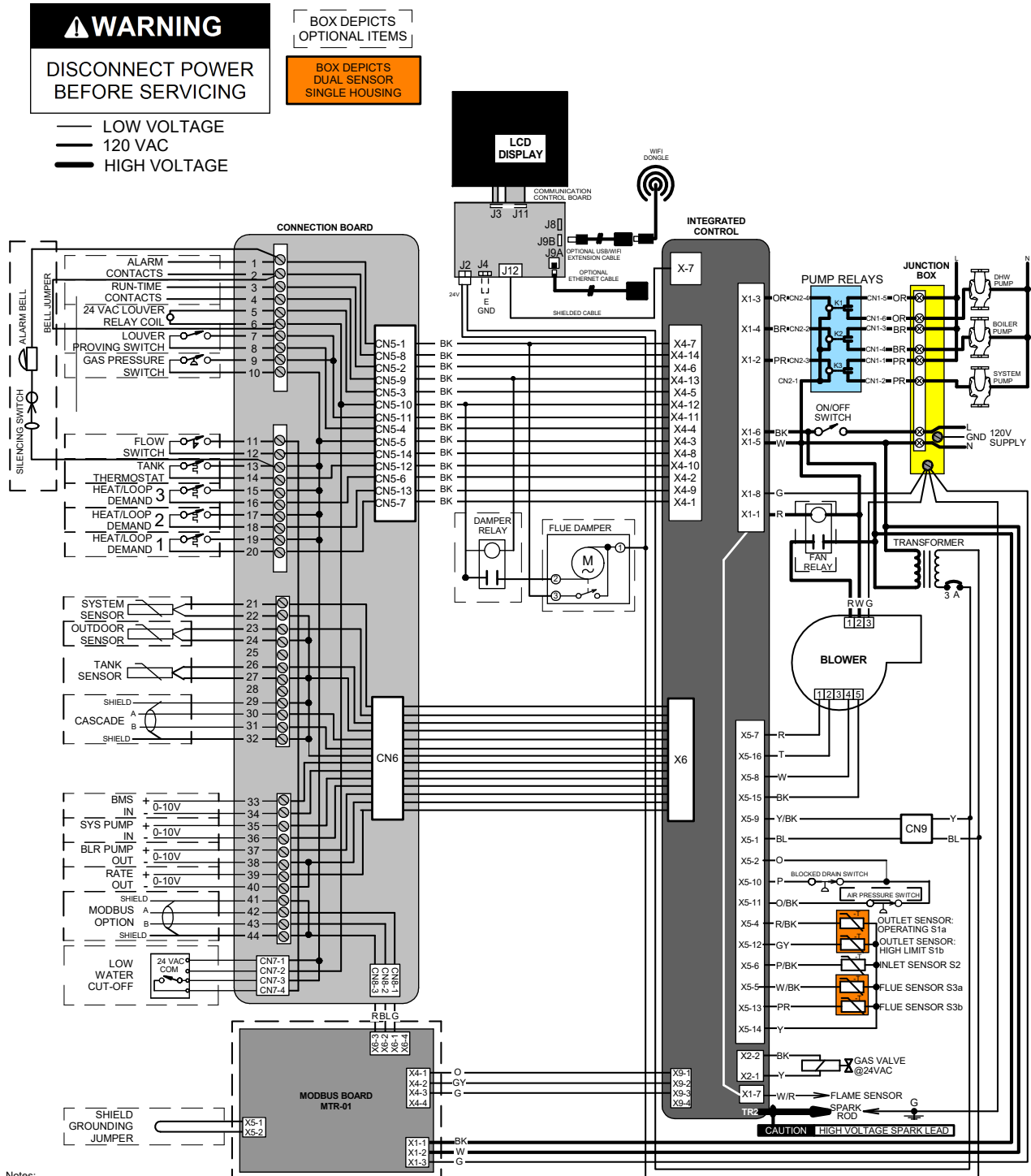

- Notes:
1. All wiring must be installed with local, state, provincial, and national code requirements per either N.E.C. in USA or C.S.A. in Canada.
 2. If any original equipment wire as supplied with appliance must be replaced, then it must be replaced with wire having same wire gauge (AWG) and rated for a minimum of 105°C. Exceptions: Replacement high voltage spark lead and ribbon cables must be purchased from the factory. Use of a non-approved spark lead or ribbon cables can lead to operational problems which could result in non-repairable damage to the integrated controller or other components.
 3. Actual connector block locations may vary from those shown on diagrams. Refer to actual components for proper connector block locations when using diagrams to trouble shoot.
 4. Where possible, switches are shown without utilities (gas, water, electricity) connected to the unit. As such, actual switch states may vary from those shown on diagrams depending upon whether utilities are connected or fault condition is present.

100329773 REV B

Revision Notes: Revision A (ECO #C06020) initial release.

Revision B (ECO #C06188) reflects updates made to the ladder and wiring diagrams (ECO #C06158).

Revision C (ECO C07191) reflects the correction information in the Parity section on page 4.

Revision D (ECO C07281) reflects the addition of Armor information and Wall Hung unit information on page 13, image 5-6 on page 15 for Wiring Requirements, Wall Hung ModBus installation procedure and images 2-6 and 2-7 on page 5, Armor Ladder and Wiring diagrams on pages 28 and 29 and Wall Hung Ladder and Wiring diagrams on pages 30 and 31. Section 2 "Installation" was created using information previously included in Section 7 "Troubleshooting".

Revision E (ECO C11616) reflects the addition of the lockout code notice on page 23 (R05772).

Revision F (ECO C11792) reflects the addition of Outdoor Knight, Knight XL and Armor models.

Revision G (ECO C13647) reflects the inclusion of AQUAS models.

Revision H (ECO C16066) reflects the addition of FTXL model information, images and diagrams.

Revision J (PCP# 3000002377 / CN# 500002607) reflects the addition of BACnet information and images, edits made to the Memory Map tables on pages 15 and 16.

Revision K (PCP# 3000007541 / CN# 500007580) reflects the addition of references to A+ and B- on page 17.

Revision L (PCP# 3000008406 / CN# 500008361) reflects an update to the addressing information of BACnet configuration on page 13.

Revision M (PCP #3000030348 / CN #500019626) reflects the addition of the Wall Mount Armor models.

Revision N (PCP #3000040588 / CN #500028510) reflects the addition of the Shield SNR/SWA models.

Revision P (PCP #3000043071 / CN #500030823) reflects the addition of the Armor AWH0400-1000 models.

Revision R (PCP #3000045243 / CN #500032780) reflects Fahrenheit and Celsius enhancement additions.

Revision T (PCP #3000054850 / CN #500041363) reflects the addition of the FTXL1000.