



Installation & Operation Manual Models: 1000 - 1500

⚠ WARNING: If the information in this manual is not followed exactly, a fire or explosion may result causing property damage, personal injury or loss of life.

-- This water heater **MUST NOT** be installed in any location where gasoline or flammable vapors are likely to be present.

-- WHAT TO DO IF YOU SMELL GAS

- Do not try to light any appliance.
- Do not touch any electric switch; do not use any phone in your building.
- Immediately call your gas supplier from a near by phone. Follow the gas supplier's instructions.
- If you cannot reach your gas supplier, call the fire department.
- Installation and service must be performed by a qualified installer, service agency, or the gas supplier.

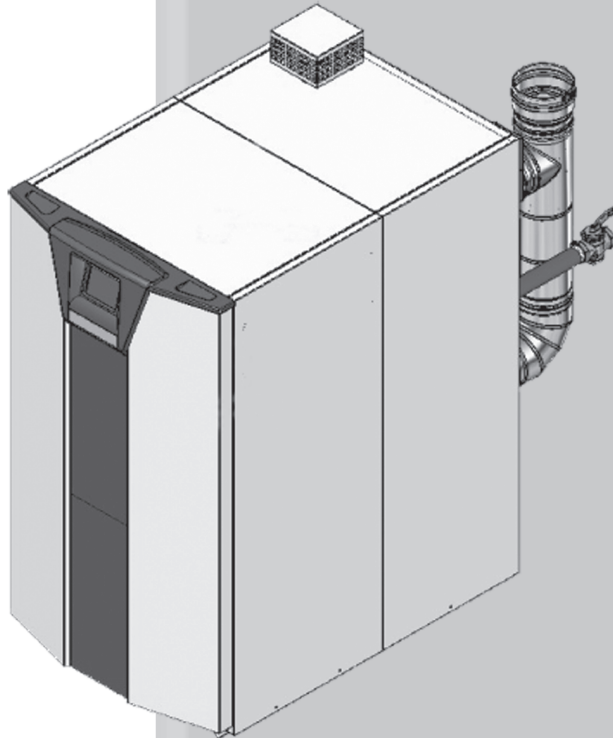

⚠ WARNING

This manual must only be used by a qualified heating installer / service technician. Read all instructions, including this manual and the Armor X2 Water Heater Service Manual, before installing. Perform steps in the order given. Failure to comply could result in severe personal injury, death, or substantial property damage.

Save this manual for future reference.



Contents

HAZARD DEFINITIONS	2	6. SYSTEM PIPING	
PLEASE READ BEFORE PROCEEDING	3	System Water Piping Methods	32
THE ARMOR X2 WATER HEATER -- HOW IT WORKS 4-5		General Piping Information.....	32
RATINGS	6	Scalding	32
1. DETERMINE WATER HEATER LOCATION		Water Chemistry.....	33
Provide Clearances	7	Piping Components.....	33
Provide Air Openings to Room.....	9	7. GAS CONNECTIONS	
Flooring and Foundation.....	9	Connecting Gas Supply Piping.....	39
Vent and Air Piping.....	9	Natural Gas.....	40
Prevent Combustion Air Contamination	9	Pipe Sizing for Natural Gas	40
Corrosive Contaminants and Sources	10	Natural Gas Supply Pressure Requirements	40
Using an Existing Vent System to Install a New Water Heater	10	Propane Gas.....	40
Removing a Water Heater from Existing Common Vent.....	11	Pipe Sizing for Propane Gas	40
Combustion and Ventilation Air Requirements.....	12-13	Propane Supply Pressure Requirements.....	40
2. PREPARE WATER HEATER		Check Inlet Gas Supply.....	41-42
Remove Water Heater from Wood Pallet.....	14	Gas Pressure	42
3. GENERAL VENTING		Gas Valve Replacement	42
Direct Venting Options	15	8. FIELD WIRING	
Install Vent and Combustion Air Piping.....	16	Line Voltage Connections	43
Requirements for Installation in Canada.....	17	Low Voltage Connections	44
Sizing	17	Wiring of the Cascade.....	44
Materials.....	18	9. CONDENSATE DISPOSAL	
Optional Room Air.....	19	Condensate Drain.....	47
PVC/CPVC.....	20	10. STARTUP	48-52
Polypropylene.....	21	11. OPERATING INFORMATION	
Stainless Steel Vent.....	22	General	53
4. SIDEWALL DIRECT VENTING		Cascade.....	55
Vent/Air Termination - Sidewall	23-29	Sequence of Operation.....	56
Determine Location.....	23-27	Armor X2 Water Heater Control Module	57
Prepare Wall Penetrations	28-29	Status Screen	57-58
Multiple Vent/Air Terminations.....	29	Main Menu Screen.....	59
5. VERTICAL DIRECT VENTING		12. MAINTENANCE	
Vent/Air Termination - Vertical.....	30-31	Maintenance & Annual Startup.....	60-65
Determine Location.....	30	13. DIAGRAMS	
Prepare Roof Penetrations	30	Ladder Diagram	66-67
Multiple Vent/Air Terminations	31	Wiring Diagram.....	68
		Revision Notes.....	Back Cover

Hazard definitions

The following defined terms are used throughout this manual to bring attention to the presence of hazards of various risk levels or to important information concerning the life of the product.

⚠ DANGER DANGER indicates an imminently hazardous situation which, if not avoided, will result in death or serious injury.

⚠ WARNING WARNING indicates a potentially hazardous situation which, if not avoided, could result in death or serious injury.

⚠ CAUTION CAUTION indicates a potentially hazardous situation which, if not avoided, may result in minor or moderate injury.

CAUTION CAUTION used without the safety alert symbol indicates a potentially hazardous situation which, if not avoided, may result in property damage.

NOTICE NOTICE indicates special instructions on installation, operation, or maintenance that are important but not related to personal injury or property damage.

Please read before proceeding

⚠ WARNING

Installer – Read all instructions, including this manual and the Armor X2 Water Heater Service Manual, before installing. Perform steps in the order given.

Have this water heater serviced/inspected by a qualified service technician, at least annually.

Failure to comply with the above could result in severe personal injury, death or substantial property damage.

NOTICE

When calling or writing about the water heater – Please have the water heater model and serial number from the water heater rating plate.

Consider piping and installation when determining water heater location.

Any claims for damage or shortage in shipment must be filed immediately against the transportation company by the consignee.

Factory warranty (shipped with unit) does not apply to units improperly installed or improperly operated.

⚠ WARNING

Failure to adhere to the guidelines on this page can result in severe personal injury, death, or substantial property damage.

⚠ WARNING

If the information in this manual is not followed exactly, a fire or explosion may result causing property damage, personal injury or loss of life.

-- This water heater **MUST NOT** be installed in any location where gasoline or flammable vapors are likely to be present.

-- WHAT TO DO IF YOU SMELL GAS

- Do not try to light any appliance.
- Do not touch any electric switch; do not use any phone in your building.
- Immediately call your gas supplier from a near by phone. Follow the gas supplier's instructions.
- If you cannot reach your gas supplier, call the fire department.
- Installation and service must be performed by a qualified installer, service agency, or the gas supplier.

⚠ WARNING

DO NOT install units in rooms or environments that contain corrosive contaminants (see Table 1A on page 10). Failure to comply could result in severe personal injury, death, or substantial property damage.

⚠ WARNING

The California Safe Drinking Water and Toxic Enforcement Act requires the Governor of California to publish a list of substances known to the State of California to cause cancer, birth defects, or other reproductive harm, and requires businesses to warn of potential exposure to such substances.

This product contains a chemical known to the State of California to cause cancer, birth defects, or other reproductive harm. This water heater can cause low level exposure to some of the substances listed in the Act.

When servicing the water heater –

- To avoid electric shock, disconnect electrical supply before performing maintenance.
- To avoid severe burns, allow the water heater to cool before performing maintenance.

Water heater operation –

- Do not block flow of combustion or ventilation air to the water heater.
- Should overheating occur or gas supply fail to shut off, do not turn off or disconnect electrical supply to circulator. Instead, shut off the gas supply at a location external to the appliance.
- Do not use this water heater if any part has been under water. The possible damage to a flooded appliance can be extensive and present numerous safety hazards. Any appliance that has been under water must be replaced.

The Armor X2 Water Heater - How it works...

1. **Access cover - front**
Provides access to the gas train and the heat exchanger.
2. **Air intake adapter**
Allows for the connection of the PVC air intake pipe to the water heater.
3. **Air pressure switches**
The air pressure switches detect blocked flue/vent conditions.
4. **Air shrouds (1.0 Model only)**
The air shrouds control air and gas flow into the burners.
5. **Automatic air vents**
Designed to remove trapped air from the heat exchanger coils.
6. **Blowers**
The blowers pull in air and gas through the venturis (item 36). Air and gas mix inside the blowers and are pushed into the burners, where they burn inside the combustion chamber.
7. **Water heater drain port**
Location from which the heat exchangers can be drained.
8. **Water heater inlet temperature sensors**
These sensors monitor inlet water temperature.
9. **Water heater outlet temperature sensors (housed with the high limit sensor)**
These sensors monitor water heater outlet water temperature.
10. **Burners (not shown)**
Made with metal fiber and stainless steel construction, the burners use pre-mixed air and gas and provide a wide range of firing rates.
11. **Condensate drain connection**
Connects the condensate drain line to a 1/2" PVC union.
12. **Control modules**
The control modules respond to internal and external signals and control the blowers, gas valves, and pumps to meet the heating demand.
13. **Electronic display**
Digital controls with touch screen technology and full color display.
14. **Flame inspection windows**
The quartz glass windows provide a view of the burner surfaces and flames.
15. **Flame sensors**
Used by the control module to detect the presence of burner flame.
16. **Flap valves**
Prevents recirculation of flue products when only one burner is running.
17. **Flue gas sensors**
These sensors monitor the flue gas exit temperature. The control modules will modulate and shut down the water heater if the flue gas temperature gets too hot. This protects the flue pipe from overheating.
18. **Flue pipe adapter**
Allows for the connection of the PVC vent pipe system to the water heater.
19. **Gas connection pipe**
Threaded 1½" pipe connection. This pipe should be connected to the incoming gas supply for the purpose of delivering gas to the water heater.
20. **Gas shutoff valves (inside unit)**
Manual valves used to isolate the gas valves from the burners.
21. **Gas shutoff valve (outside unit)**
Manual valve used to isolate the gas valve from the gas supply.
22. **Gas valves**
The gas valves sense the negative pressure created by the blowers, allowing gas to flow only if the gas valves are powered and combustion air is flowing.
23. **Heat exchanger access covers**
Allows access to the combustion side of the heat exchanger coils.
24. **Manual Reset High Limit (MRHL)**
Device used to monitor the outlet water temperature. If the temperature exceeds its setting, it will break the control circuit, shutting the water heater down.
25. **Ignition electrodes**
Provides direct spark for igniting the burners.
26. **Line voltage junction box**
The junction box contains the connection points for the line voltage power and all pumps.
27. **Line voltage wiring connections (knockouts)**
Conduit connection points for the high voltage junction box.
28. **Low voltage connection board**
The connection board is used to connect external low voltage devices.
29. **Low voltage wiring connections (knockouts)**
Conduit connection points for the low voltage connection board.
30. **Power switch**
Turns 120 VAC ON/OFF to the heater.
31. **Pump relay board**
The pump relay board is used to control the HW pumps.
32. **Relief valve**
Protects the heat exchangers from an over pressure condition. The relief valve will be set at 150 PSI and 210°F.
33. **Stainless steel heat exchangers**
Allows system water to flow through specially designed coils for maximum heat transfer, while providing protection against flue gas corrosion. The coils are encased in a jacket that contains the combustion process.
34. **Top panel**
Removable panel to gain access to the internal components.
35. **Venturis**
The venturis control air and gas flow into the burners.
36. **Water inlets**
Two 2" NPT water connections that return water from the system to the heat exchangers.
37. **Water outlets**
A 3" NPT stainless steel water connection that supplies hot water to the system.
38. **O-temp switch (located underneath access cover)**
An electrical switch designed to shut down water heater operation in the event the outer back of the heat exchanger, directly above the flue connection does not exceed 604°F (318°C). This is a one time switch and could warrant a heat exchanger replacement. Check the integrity of the rear refractory at the back of the upper coil if the switch opens.
39. **Flow switch**
The flow switch is a safety device that ensures flow through the heat exchanger during operation. This appliance is low mass and should never be operated without flow. The flow switch makes contact when flow is detected and allows the unit to operate. If flow is discontinued during operation for any reason the flow switch will break the control circuit and the unit will shut down.
40. **Limiting thermostat**
The limiting thermostat is used to prevent the outlet water of the heat exchangers from exceeding 190°F.
41. **Burner door temperature switch**
An electrical switch designed to shut down water heater operation in the event the combustion chamber access cover exceeds 500°F (260°C). This switch may only be reset by a qualified service technician AFTER the underlying cause has been identified and corrected. Check the integrity of the front refractory on the inside of the combustion chamber access cover if the switch opens.

The Armor X2 Water Heater - How it works... *(continued)*

Models 1.0 - 1.3 - 1.5

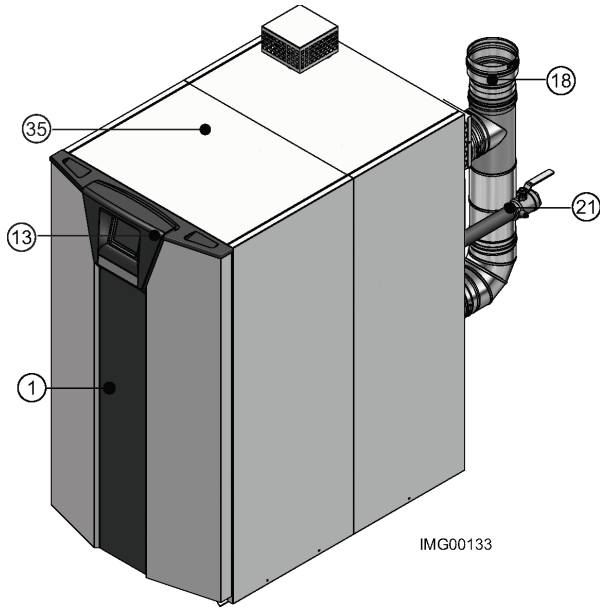

IMG00133

Front View

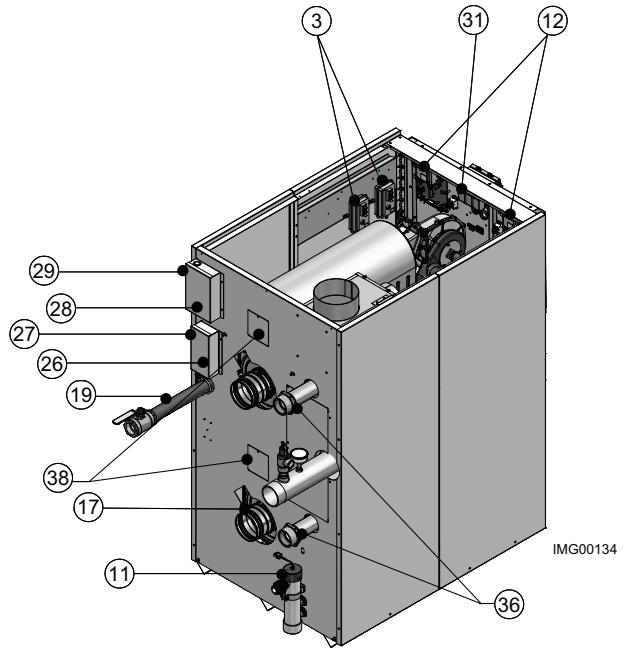

IMG00134

Rear View

1.0 MODEL ONLY

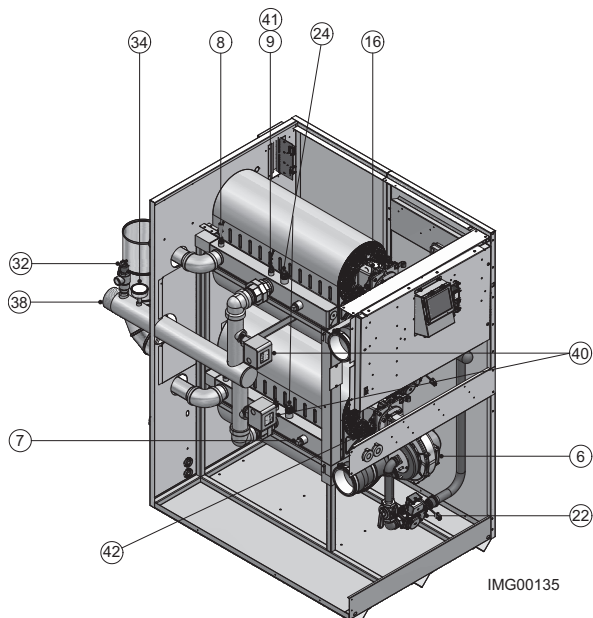
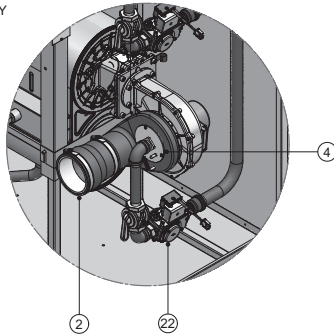

IMG00135

Left Side (inside unit)

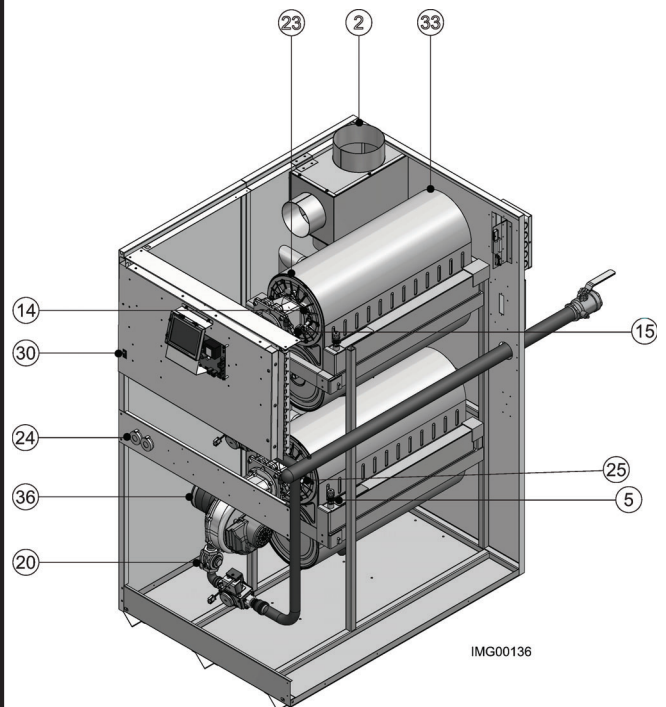

IMG00136

Right Side (inside unit)

Ratings



LOW LEAD CONTENT

Model Number Note: Change "N" to "L" for L.P. gas models.	CSA Input Modulation Btu/hr (Note 2, 3)	Water Content Gallons	Water Connections		Gas Connections	Vent/Air Size (Note 1)
			Inlet	Outlet		
AWN1000	99,900 - 999,000	9.5	2"	3"	1 1/2"	6"
AWN1300	130,000 - 1,300,000	10.3	2"	3"	1 1/2"	6"
AWN1500	150,000 - 1,500,000	11.0	2"	3"	1 1/2"	6"

NOTICE

Maximum allowed working pressure is located on the rating plate.

Notes:

1. Armor X2 water heaters require special gas venting. Use only the vent materials and methods specified in the Armor X2 Installation and Operation Manual.
2. Standard Armor X2 water heaters are equipped to operate from sea level to 4,500 feet **only** with no adjustments. The water heater will de-rate by 4% for each 1,000 feet above sea level up to 4,500 feet.
3. High altitude Armor X2 water heaters are equipped to operate from 3,000 to 12,000 feet **only**. The water heater will de-rate by 2% for each 1,000 feet above sea level. High altitude models are manufactured with a different control module for altitude operation, but the operation given in this manual remains the same as the standard water heaters. A high altitude label (as shown in FIG. A) is also affixed to the unit.
Derate values are based on proper combustion calibration and CO₂'s adjusted to the recommended levels.
4. The manual reset high limit provided with the Armor X2 is listed to UL353.

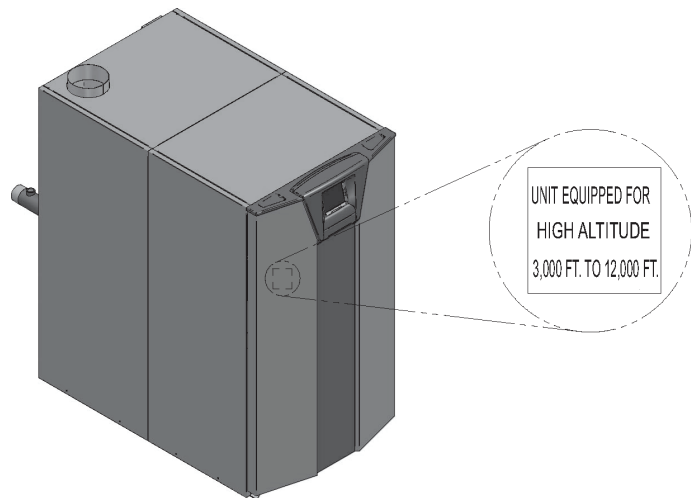

Figure A High Altitude Label Location

1 Determine water heater location

Installation must comply with:

- Local, state, provincial, and national codes, laws, regulations, and ordinances.
- National Fuel Gas Code, ANSI Z223.1 – latest edition.
- National Electrical Code.
- For Canada only: B149.1 Installation Code, CSA C22.1 Canadian Electrical Code Part 1 and any local codes.

NOTICE

The Armor X2 water heater gas manifold and controls met safe lighting and other performance under tests specified in ANSI Z21.10.3 – latest edition.

Before locating the water heater, check:

1. Check for nearby connection to:
 - Water piping
 - Venting connections
 - Gas supply piping
 - Electrical power
2. Locate the appliance so that if water connections should leak, water damage will not occur. When such locations cannot be avoided, it is recommended that a suitable drain pan, adequately drained, be installed under the appliance. The pan must not restrict combustion air flow. Under no circumstances is the manufacturer to be held responsible for water damage in connection with this appliance, or any of its components.
3. Check area around the water heater. Remove any combustible materials, gasoline and other flammable liquids.

WARNING

Failure to keep water heater area clear and free of combustible materials, gasoline, and other flammable liquids and vapors can result in severe personal injury, death, or substantial property damage.

4. The Armor X2 water heater must be installed so that gas control system components are protected from dripping or spraying water or rain during operation or service.
5. If a new water heater will replace an existing water heater, check for and correct system problems, such as:
 - System leaks causing oxygen corrosion or heat exchanger cracks from hard water deposits.
6. Check around the water heater for any potential air contaminants that could risk corrosion to the water heater or the water heater combustion air supply (see Table 1A on page 10). Prevent combustion air contamination. Remove any of these contaminants from the water heater area.

WARNING

DO NOT install units in rooms or environments that contain corrosive contaminants (see Table 1A on page 10). Failure to comply could result in severe personal injury, death, or substantial property damage.

WARNING

This appliance is certified as an indoor appliance. Do not install the appliance outdoors or locate where the appliance will be exposed to freezing temperatures or to temperatures that exceed 100°F.

Do not install the appliance where the relative humidity may exceed 93%. Do not install the appliance where condensation may form on the inside or outside of the appliance, or where condensation may fall onto the appliance.

Failure to install the appliance indoors could result in severe personal injury, death, or substantial property damage.

WARNING

This appliance requires a special venting system. Use only the vent materials, primer and cement specified in this manual to make the vent connections. Failure to follow this warning could result in fire, personal injury, or death.

Closet and alcove installations

A closet is any room the water heater is installed in which is less than 778 cubic feet for AW1000 models, 847 cubic feet for AW1300 models, and 914 cubic feet for AW1500 models.

An alcove is any room which meets the criteria for a closet with the exception that it does not have a door.

Example: Room dimensions = 9 feet long, 9 feet wide, and 9 foot ceiling = $9 \times 9 \times 9 = 729$ cubic feet. This would be considered a closet for a Armor X2 water heater.

WARNING

For closet and alcove installations as shown in FIG.'s 1-1 and 1-2, CPVC, polypropylene, and stainless steel vent material must be used inside the structure. The ventilating air openings shown in FIG.'s 1-1 and 1-2 are required for this arrangement. Failure to follow this warning could result in fire, personal injury, or death.

Provide clearances:

Clearances from combustible materials

1. Hot water pipes—at least 1/4" from combustible materials.
2. Vent pipe – at least 1" from combustible materials.
3. See FIG.'s 1-1 and 1-2 on page 8 for other clearance minimums.

Clearances for service access

1. See FIG.'s 1-1 and 1-2 on page 8 for recommended service clearances. If you do not provide the minimum clearances shown, it may not be possible to service the water heater without removing it from the space.

1 Determine water heater location

Figure 1-1 Closet Installation - Minimum Required Clearances

(6 MM) MINIMUM CLEARANCE
AROUND HOT WATER PIPES
(25 MM) MINIMUM CLEARANCE
AROUND VENT PIPES



WARNING

For closet installations, CPVC, polypropylene or stainless steel vent material **MUST BE** used in a closet structure due to elevated temperatures. Failure to follow this warning could result in fire, personal injury, or death.

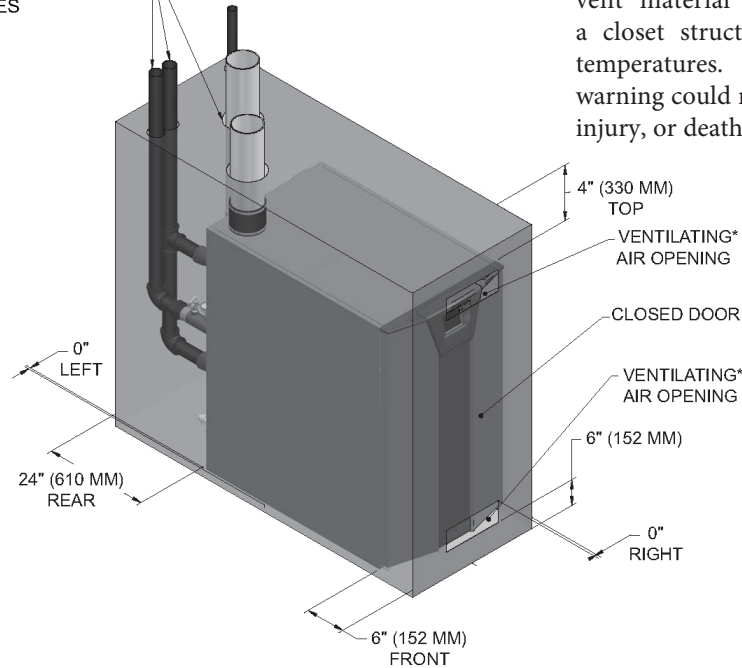

RECOMMENDED SERVICE CLEARANCES:

Front - 30" (762 mm)
Top - 24" (610 mm)
Left Side - 24" (610 mm)
Rear - 24" (610 mm)

*AREA OF EACH OPENING:
1 SQ. INCH PER 1000 BTU PER HOUR IN
WITH A MINIMUM OF 100 SQ. INCHES

Figure 1-2 Alcove Installation - Minimum Required Clearances

1/4" (6 MM) MINIMUM CLEARANCE
AROUND HOT WATER PIPES
1" (25 MM) MINIMUM CLEARANCE
AROUND VENT PIPES



WARNING

For alcove installations, CPVC, polypropylene or stainless steel vent material **MUST BE** used in an alcove structure due to elevated temperatures. Failure to follow this warning could result in fire, personal injury, or death.

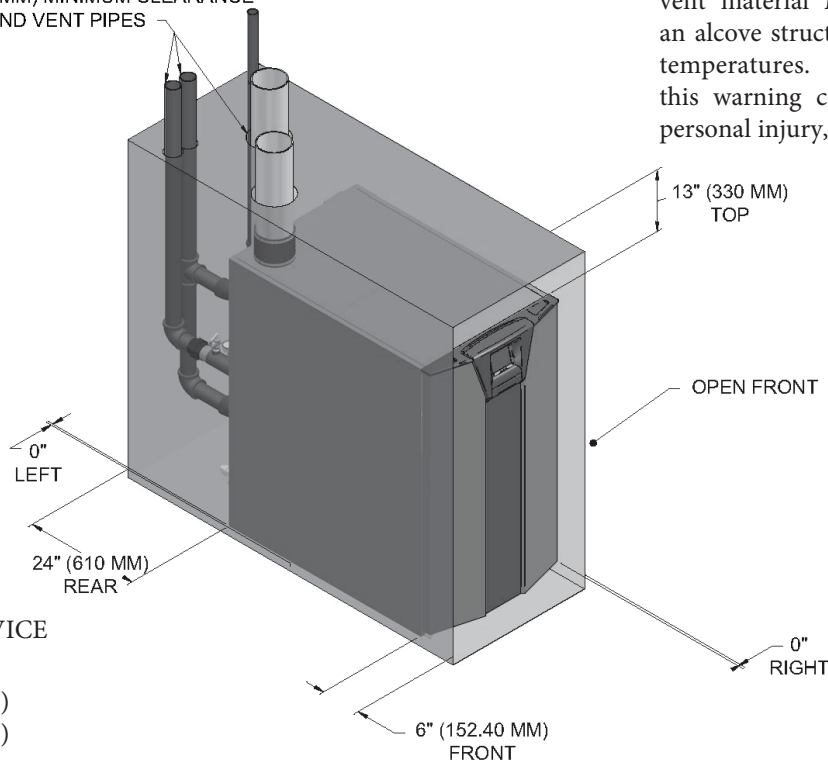

RECOMMENDED SERVICE CLEARANCES:

Front - 30" (762 mm)
Top - 24" (610 mm)
Left Side - 24" (610 mm)
Rear - 24" (610 mm)

1 Determine water heater location *(continued)*

Provide air openings to room:

The Armor X2 alone in boiler room

1. No air ventilation openings into the boiler room are needed when clearances around the Armor X2 are at least equal to the SERVICE clearances shown in FIG.'s 1-1 and 1-2. For spaces that do NOT supply this clearance, provide two openings as shown in FIG. 1-1. Each opening must provide one square inch free area per 1,000 Btu/hr of water heater input.
2. Combustion air openings are required when using the Room Air Option on page 19 of this manual.

The Armor X2 in same space with other gas or oil-fired appliances

1. Follow the National Fuel Gas Code (U.S.) or CSA B149.1 (Canada) to size/verify size of the combustion/ventilation air openings into the space.

⚠ WARNING The space must be provided with combustion/ventilation air openings correctly sized for all other appliances located in the same space as the Armor X2.

Do not install the water heater in an attic.

Failure to comply with the above warnings could result in severe personal injury, death, or substantial property damage.

2. Size openings only on the basis of the other appliances in the space. No additional air opening free area is needed for the Armor X2 because it takes its combustion air from outside (direct vent installation).

Flooring and foundation

Flooring

The Armor X2 is approved for installation on combustible flooring, but must never be installed on carpeting.

⚠ WARNING Do not install the water heater on carpeting even if foundation is used. Fire can result, causing severe personal injury, death, or substantial property damage.

If flooding is possible, elevate the water heater sufficiently to prevent water from reaching the water heater.

Vent and air piping

The Armor X2 requires a special vent system, designed for pressurized venting.

The water heater is to be used for either direct vent installation or for installation using indoor combustion air. When room air is considered, see Section 5, Vertical Direct Venting. Note prevention of combustion air contamination below when considering vent/air termination.

Vent and air must terminate near one another and may be vented vertically through the roof or out a side wall, unless otherwise specified. You may use any of the vent/air piping methods covered in this manual. Do not attempt to install the Armor X2 using any other means.

Be sure to locate the water heater such that the vent and air piping can be routed through the building and properly terminated. The vent/air piping lengths, routing and termination method must all comply with the methods and limits given in this manual.

Prevent combustion air contamination

Install air inlet piping for the Armor X2 as described in this manual. Do not terminate vent/air in locations that can allow contamination of combustion air. Refer to Table 1A, page 10 for products and areas which may cause contaminated combustion air.

⚠ WARNING Ensure that the combustion air will not contain any of the contaminants in Table 1A, page 10. Contaminated combustion air will damage the water heater, resulting in possible severe personal injury, death or substantial property damage. Do not pipe combustion air near a swimming pool, for example. Also, avoid areas subject to exhaust fumes from laundry facilities. These areas will always contain contaminants.

1 Determine water heater location

Table 1A Corrosive Contaminants and Sources

Products to avoid:
Spray cans containing chloro/fluorocarbons
Permanent wave solutions
Chlorinated waxes/cleaners
Chlorine-based swimming pool chemicals
Calcium chloride used for thawing
Sodium chloride used for water softening
Refrigerant leaks
Paint or varnish removers
Hydrochloric acid/muriatic acid
Cements and glues
Antistatic fabric softeners used in clothes dryers
Chlorine-type bleaches, detergents, and cleaning solvents found in household laundry rooms
Adhesives used to fasten building products and other similar products
Areas likely to have contaminants
Dry cleaning/laundry areas and establishments
Swimming pools
Metal fabrication plants
Beauty shops
Refrigeration repair shops
Photo processing plants
Auto body shops
Plastic manufacturing plants
Furniture refinishing areas and establishments
New building construction
Remodeling areas
Garages with workshops

When using an existing vent system to install a new water heater:

WARNING Failure to follow all instructions can result in flue gas spillage and carbon monoxide emissions, causing severe personal injury or death.

Check the following venting components before installing:

- Material** - For materials listed for use with this appliance, see Section 3 - General Venting. For polypropylene or stainless steel venting, an adapter of the same manufacturer must be used at the flue collar connection.
- Size** - To ensure proper pipe size is in place, see Table 3A. Check to see that this size is used throughout the vent system.
- Manufacturer** - For a stainless steel or polypropylene application, you must use only the listed manufacturers and their type product listed in Tables 3E and 3F for CAT IV positive pressure venting with flue producing condensate.
- Supports** - Non-combustible supports must be in place allowing a minimum 1/4" rise per foot. The supports should adequately prevent sagging and vertical slippage, by distributing the vent system weight. For additional information, consult the vent manufacturer's instructions for installation.
- Terminations** - Carefully review Sections 3 through 5 to ensure requirements for the location of the vent and air terminations are met and orientation of these fit the appropriate image from the Horizontal or Vertical options listed in the General Venting Section. For stainless steel vent, only use terminations listed in Table 3F for the manufacturer of the installed vent.
- Seal** - With prior requirements met, the system should be tested to the procedure listed in parts (c) through (f) of the Removal of an Existing Water Heater Section on page 11.

With polypropylene and stainless steel vent, seal and connect all pipe and components as specified by the vent manufacturer used; with PVC/CPVC vent, see the Installing Vent or Air Piping Section on page 20.

WARNING If any of these conditions are not met, the existing system must be updated or replaced for that concern. Failure to follow all instructions can result in flue gas spillage and carbon monoxide emissions, causing severe personal injury or death.

1 Determine water heater location *(continued)*

When removing a water heater from existing common vent system:

⚠ DANGER

Do not install the Armor X2 into a common vent with any other appliance. This will cause flue gas spillage or appliance malfunction, resulting in possible severe personal injury, death, or substantial property damage.

⚠ WARNING

Failure to follow all instructions can result in flue gas spillage and carbon monoxide emissions, causing severe personal injury or death.

At the time of removal of an existing water heater, the following steps shall be followed with each appliance remaining connected to the common venting system placed in operation, while the other appliances remaining connected to the common venting system are not in operation.

- a. Seal any unused openings in the common venting system.
- b. Visually inspect the venting system for proper size and horizontal pitch and determine there is no blockage or restriction, leakage, corrosion, or other deficiencies, which could cause an unsafe condition.
- c. Test vent system – Insofar as is practical, close all building doors and windows and all doors between the space in which the appliances remaining connected to the common venting system are located and other spaces of the building. Turn on clothes dryers and any appliance not connected to the common venting system. Turn on any exhaust fans, such as range hoods and bathroom exhausts, so they will operate at maximum speed. Do not operate a summer exhaust fan. Close fireplace dampers.
- d. Place in operation the appliance being inspected. Follow the lighting instructions. Adjust thermostat so appliance will operate continuously.
- e. Test for spillage at the draft hood relief opening after 5 minutes of main burner operation. Use the flame of a match or candle, or smoke from a cigarette, cigar, or pipe.
- f. After it has been determined that each appliance remaining connected to the common venting system properly vents when tested as outlined herein, return doors, windows, exhaust fans, fireplace dampers, and any other gas-burning appliance to their previous conditions of use.
- g. Any improper operation of the common venting system should be corrected so the installation conforms with the National Fuel Gas Code, ANSI Z223.1/NFPA 54 and/or CAN/CSA B149.1, Natural Gas and Propane Installation Code. When resizing any portion of the common venting system, the common venting system should be resized to approach the minimum size as determined using the appropriate tables in Part 11 of the National Fuel Gas Code, ANSI Z223.1/NFPA and/or CAN/CSA B149.1, Natural Gas and Propane Installation Code.

1 Determine water heater location

Combustion and ventilation air requirements for appliances drawing air from the equipment room

Provisions for combustion and ventilation air must be in accordance with Air for Combustion and Ventilation, of the latest edition of the National Fuel Gas Code, ANSI Z223.1, in Canada, the latest edition of CGA Standard B149 Installation Code for Gas Burning Appliances and Equipment, or applicable provisions of the local building codes.

The equipment room MUST be provided with properly sized openings to assure adequate combustion air and proper ventilation.

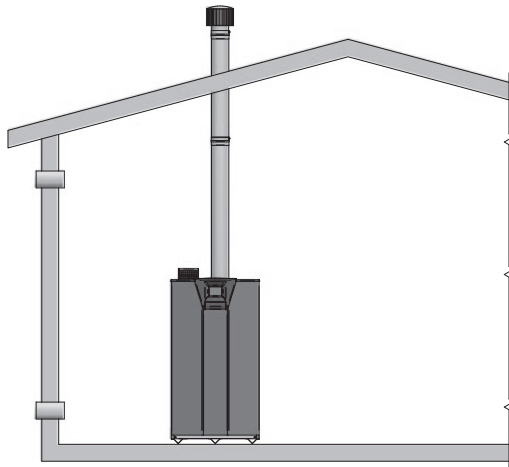

Figure 1-3_Combustion Air Direct from Outside

1. If air is taken directly from outside the building with no duct, provide two permanent openings to the equipment room (see FIG. 1-3):
 - (a) Combustion air opening, with a minimum free area of one square inch per 4000 Btu/hr input (5.5 cm² per kW). This opening must be located within 12" (30 cm) of the bottom of the enclosure.
 - (b) Ventilation air opening, with a minimum free area of one square inch per 4000 Btu/hr input (5.5 cm² per kW). This opening must be located within 12" (30 cm) of the top of the enclosure.

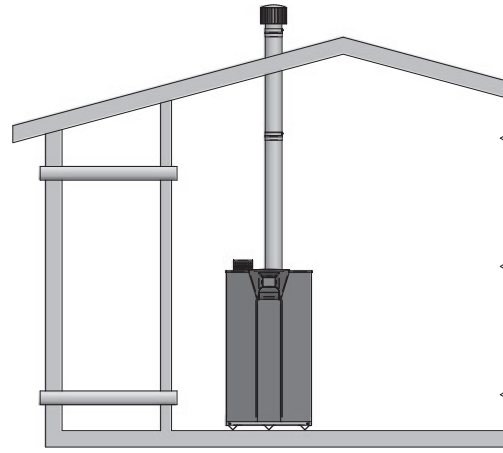

Figure 1-4_Combustion Air Through Ducts

2. If combustion and ventilation air is taken from the outdoors using a duct to deliver the air to the equipment room, each of the two openings should be sized based on a minimum free area of one square inch per 2000 Btu/hr (11 cm² per kW) of input (see FIG. 1-4).

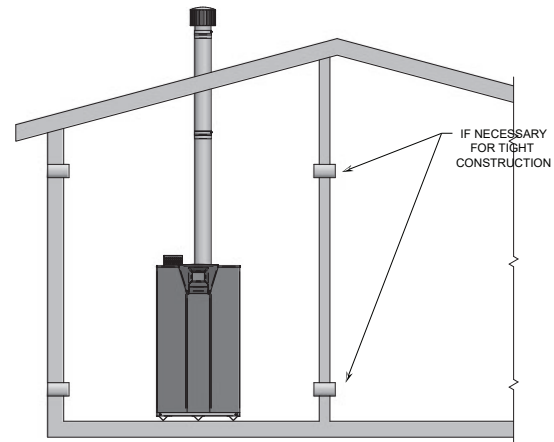

Figure 1-5_Combustion Air from Interior Space

3. If air is taken from another interior space, each of the two openings specified above should have a net free area of one square inch for each 1000 Btu/hr (22 cm² per kW) of input, but not less than 100 square inches (645 cm²) (see FIG. 1-5).

1 Determine water heater location *(continued)*

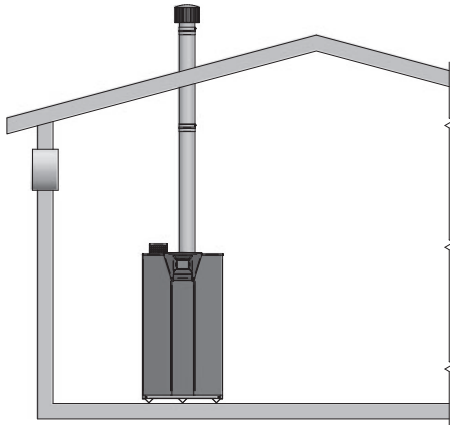

Figure 1-6 Combustion Air from Outside - Single Opening

- If a single combustion air opening is provided to bring combustion air in directly from the outdoors, the opening must be sized based on a minimum free area of one square inch per 3000 Btu/hr (7 cm² per kW). This opening must be located within 12" (30 cm) of the top of the enclosure (see FIG. 1-6).

Combustion air requirements are based on the latest edition of the National Fuel Gas Code, ANSI Z223.1; in Canada refer to the latest edition of CGA Standard CAN B149.1. Check all local code requirements for combustion air.

All dimensions based on net free area in square inches. Metal louvers or screens reduce the free area of a combustion air opening a minimum of approximately 25%. Check with louver manufacturers for exact net free area of louvers.

Where two openings are provided, one must be within 12" (30cm) of the ceiling and one must be within 12" (30cm) of the floor of the equipment room. Each opening must have net free area as specified in the chart below (Table 1B). Single openings shall commence within 12" (30cm) of the ceiling.

CAUTION Under no circumstances should the equipment room ever be under negative pressure. Particular care should be taken where exhaust fans, attic fans, clothes dryers, compressors, air handling units, etc., may take away air from the unit.

The combustion air supply must be completely free of any flammable vapors that may ignite or chemical fumes which may be corrosive to the appliance. Common corrosive chemical fumes which must be avoided are fluorocarbons and other halogenated compounds, most commonly present as refrigerants or solvents, such as Freon, trichlorethylene, perchlorethylene, chlorine, etc. These chemicals, when burned, form acids which quickly attack the stainless steel heat exchanger, headers, flue collectors, and the vent system.

The result is improper combustion and a non-warrantable, premature appliance failure.

EXHAUST FANS: Any fan or equipment which exhausts air from the equipment room may deplete the combustion air supply and/or cause a downdraft in the venting system. Spillage of flue products from the venting system into an occupied living space can cause a very hazardous condition that must be corrected immediately.

TABLE - 1B MINIMUM RECOMMENDED COMBUSTION AIR SUPPLY TO EQUIPMENT ROOM							
Model Number	FIG. 1-3		FIG. 1-4		FIG. 1-5		FIG. 1-6
	*Outside Air from 2 Openings Directly from Outdoors		*Outside Air from 2 Ducts Delivered from Outdoors		**Inside Air from 2 Ducts Delivered from Interior Space		
	Top Opening, in ²	Bottom Opening, in ²	Top Opening, in ²	Bottom Opening, in ²	Top Opening, in ²	Bottom Opening, in ²	
1000	250 (1613 cm ²)	250 (1613 cm ²)	500 (3226 cm ²)	500 (3226 cm ²)	1000 (6452 cm ²)	1000 (6452 cm ²)	333 (2149 cm ²)
1300	325 (2097 cm ²)	325 (2097 cm ²)	650 (4194 cm ²)	650 (4194 cm ²)	1300 (8388 cm ²)	1300 (8388 cm ²)	433 (2794 cm ²)
1500	375 (2420 cm ²)	375 (2420 cm ²)	750 (4839 cm ²)	750 (4839 cm ²)	1500 (9678 cm ²)	1500 (9678 cm ²)	500 (3226 cm ²)

*Outside air openings shall directly communicate with the outdoors. When combustion air is drawn from the outside through a duct, the net free area of each of the two openings must have twice (2 times) the free area required for Outside Air/2 Openings. The above requirements are for the appliance only; additional gas fired appliances in the equipment room will require an increase in the net free area to supply adequate combustion air for all appliances.

Combined interior space must be 50 cubic feet per 1,000 Btu/hr input. **Buildings MUST NOT be of **"Tight Construction". For buildings of **"Tight Construction", provide air openings into the building from outside.

*No combustion air openings are needed when the appliance is installed in a space with a volume NO LESS than 50 cubic feet per 1,000 Btu/hr of all installed gas fired appliances. **Buildings MUST NOT be of **"Tight Construction"**.

**"Tight Construction" is defined as a building with less than 0.40 ACH (air changes per hour).

2 Prepare water heater

Remove water heater from wood pallet

1. After removing the outer shipping carton from the water heater, remove the parts package (packaged parts inside the jacket of the water heater).
2. To remove the water heater from the pallet:
 - a. Remove the front door of the water heater.
 - b. Remove the two lag bolts from the wood pallet inside the water heater (FIG. 2-1).
 - c. Detach the water heater from the lag bolts in the rear of the unit, see FIG. 2-1.

NOTICE

Do not drop the water heater or bump the jacket on the floor or pallet. Damage to the water heater can result.

Figure 2-1 Water heater Mounted on Shipping Pallet

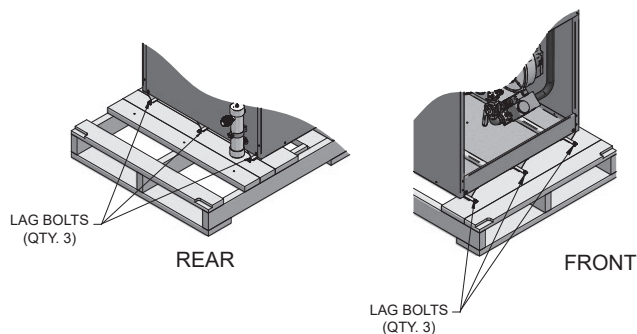

Maintain minimum specified clearances for adequate operation. All installations must allow sufficient space for servicing the vent connections, water pipe connections, piping and other auxiliary equipment, as well as the appliance. The clearance labels on each appliance note the same service and combustible clearance requirements as shown in this manual.

Multiple appliances may be installed in a modular water heater installation. Multiple appliances may be installed side by side with no clearance between adjacent appliances because this appliance is approved for zero clearance from combustible surfaces and no service access is required from the sides.

Consult the *Venting* section of this manual for specific installation instructions for the appropriate type of venting system that you will be using.

3 General venting

Direct venting options - Sidewall Vent

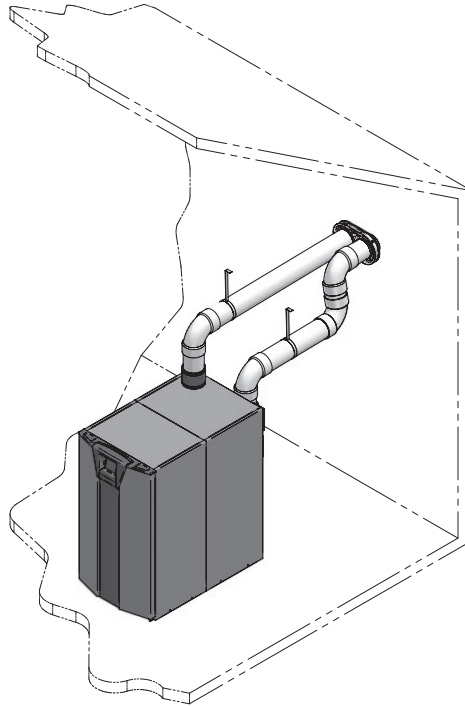

Figure 3-1 Two-Pipe Sidewall Termination - See page 23 for more details

Direct venting options - Vertical Vent

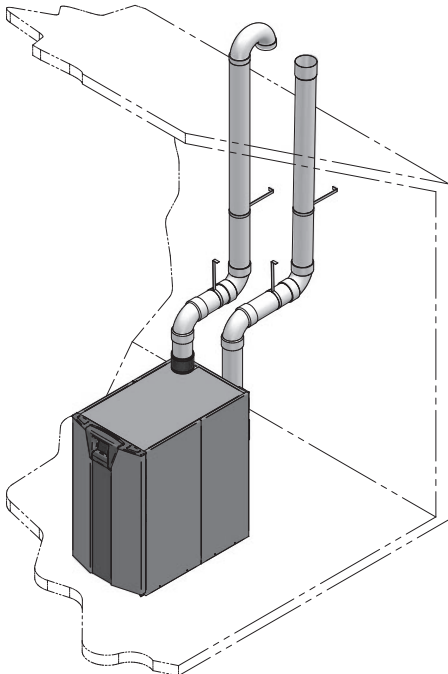

Figure 3-2 Two-Pipe Vertical Termination - See page 30 for more details

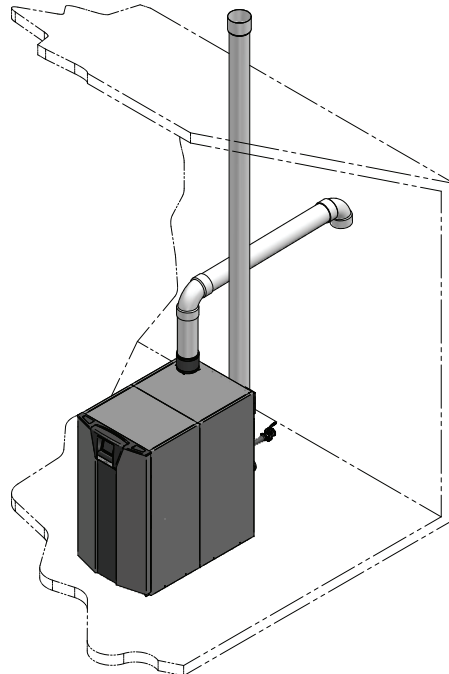

Figure 3-3 Vertical Vent, Sidewall Air

3 General venting

Install vent and combustion air piping

⚠ DANGER

The Armor X2 water heater must be vented and supplied with combustion and ventilation air as described in this section. Ensure the vent and air piping and the combustion air supply comply with these instructions regarding vent system, air system, and combustion air quality. See also Section 1 of this manual.

Inspect finished vent and air piping thoroughly to ensure all are airtight and comply with the instructions provided and with all requirements of applicable codes.

Failure to provide a properly installed vent and air system will cause severe personal injury or death.

⚠ WARNING

This appliance requires a special venting system. Use only approved stainless steel, PVC, CPVC or polypropylene pipe and fittings listed in Tables 3C, 3E, and 3F for vent pipe, and fittings. Failure to comply could result in severe personal injury, death, or substantial property damage.

⚠ WARNING

DO NOT mix components from different systems. The vent system could fail, causing leakage of flue products into the living space. Mixing of venting materials will void the warranty and certification of the appliance.

NOTICE

Installation must comply with local requirements and with the National Fuel Gas Code, ANSI Z223.1 for U.S. installations or CSA B149.1 for Canadian installations.

⚠ WARNING

For closet and alcove installations, CPVC, polypropylene or stainless steel material **MUST BE** used in a closet/alcove structure. Failure to follow this warning could result in fire, personal injury, or death.

⚠ CAUTION

Improper installation of venting systems may result in injury or death.

NOTICE

Follow the instructions in Section 1, page 11 of this manual when removing a water heater from an existing vent system.

⚠ WARNING

Do not connect any other appliance to the vent pipe or multiple water heaters to a common vent pipe. Failure to comply could result in severe personal injury, death, or substantial property damage.

The Armor X2 water heater vent and air piping can be installed through the roof or through a sidewall. Follow the procedures in this manual for the method chosen. Refer to the information in this manual to determine acceptable vent and air piping length.

You may use any of the vent/air piping methods covered in this manual. Do not attempt to install the Armor X2 water heater using any other means.

You must also install air piping from outside to the water heater air intake adapter unless following the Optional Room Air instructions on page 19 of this manual. The resultant installation is direct vent (sealed combustion).

Air intake/vent connections

1. **Combustion Air Intake Connector** (FIG. 3-4) - Used to provide combustion air directly to the unit from outdoors. A fitting is provided with the unit for final connection. Combustion air piping must be supported per guidelines listed in the National Mechanical Code, Section 305, Table 305.4 or as local codes dictate.
2. **Vent Connector** (FIG.'s 3-5 thru 3-8) - Used to provide a passageway for conveying combustion gases to the outside. A transition fitting is provided on the unit for final connection. Vent piping must be supported per the National Building Code, Section 305, Table 305.4 or as local codes dictate.

Figure 3-4 Near Water Heater Air Piping

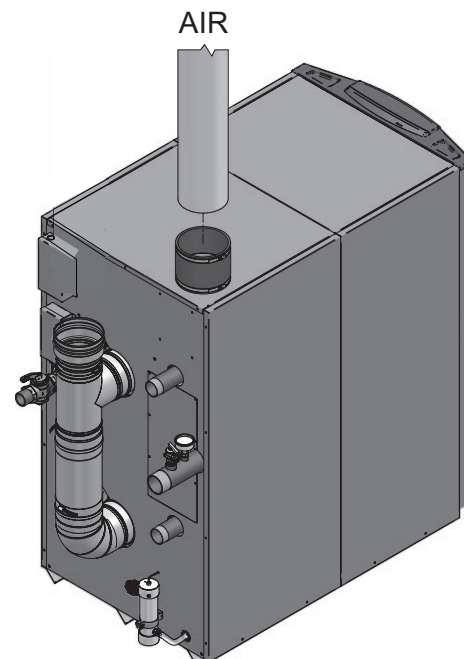

3 General venting *(continued)*

Requirements for installation in Sizing

Canada

1. Installations must be made with a vent pipe system certified to ULC-S636.
2. The first three (3) feet of plastic vent pipe from the appliance flue outlet must be readily accessible for visual inspection.
3. The components of the certified vent system must not be interchanged with other vent systems or unlisted pipe/fittings.

The Armor X2 water heater uses model specific combustion air intake and vent piping sizes as detailed in Table 3A below.

When determining equivalent combustion air and vent length, add 5 feet for each 90° elbow and 3 feet for each 45° elbow.

EXAMPLE: 20 feet of PVC pipe + (4) 90° elbows + (2) 45° elbows + (1) concentric vent kit (100140480) = 49 equivalent feet of piping.

Table 3A Air Intake/Vent Piping Sizes

Model	Air Intake Diameter	Air Intake Min. Length	Air Intake Max. Length	Vent Diameter	Vent Min. Length	Vent Max. Length	Input De-Rate per 25 feet of Vent
AW 1000	6"	12'	100'	6"	12'	100'	1.25%*
AW 1300	6"	12'	50'	6"	12'	50'	2.90%
AW 1300	7"	12'	100'	7"	12'	100'	0.95%
AW 1500	6"	12'	50'	6"	12'	50'	3.30%
AW 1500	7"	12'	100'	7"	12'	100'	1.65%

*LP models will derate by 1.5% per 25 feet of vent pipe.

Note: When using a 7" vent or air pipe, a field supplied increaser is required.

NOTICE

Increasing or decreasing combustion air or vent piping sizes is not authorized.

3 General venting

Materials

Air inlet pipe materials:

The air inlet pipe(s) must be sealed. Choose acceptable combustion air inlet pipe materials from the following list:

- PVC, CPVC, Polypropylene or ABS
- Dryer Vent or Sealed Flexible Duct (not recommended for rooftop air inlet)
- Galvanized steel vent pipe with joints and seams sealed as specified in this section.
- Type “B” double-wall vent with joints and seams sealed as specified in this section.
- AL29-4C, stainless steel material to be sealed to specification of its manufacturer.

*Plastic pipe may require an adapter (not provided) to transition between the air inlet connection on the appliance and the plastic air inlet pipe.

WARNING

Using air intake materials other than those specified can result in personal injury, death or property damage.

NOTICE

The use of double-wall vent or insulated material for the combustion air inlet pipe is recommended in cold climates to prevent the condensation of airborne moisture in the incoming combustion air.

Sealing of Type “B” double-wall vent material or galvanized vent pipe material used for air inlet piping on a sidewall or vertical rooftop Combustion Air Supply System:

- a. Seal all joints and seams of the air inlet pipe using either Aluminum Foil Duct Tape meeting UL Standard 723 or 181A-P or a high quality UL Listed silicone sealant such as those manufactured by Dow Corning or General Electric.
- b. Do not install seams of vent pipe on the bottom of horizontal runs.
- c. Secure all joints with a minimum of three (3) sheet metal screws or pop rivets. Apply Aluminum Foil Duct Tape or silicone sealant to all screws or rivets installed in the vent pipe.
- d. Ensure that the air inlet pipes are properly supported.

The PVC, CPVC, or ABS air inlet pipe should be cleaned and sealed with the pipe manufacturer’s recommended solvents and standard commercial pipe cement for the material used. The PVC, CPVC, ABS, Dryer Vent or Flex Duct air inlet pipe should use a silicone sealant to ensure a proper seal at the appliance connection and the air inlet cap connection. Dryer vent or flex duct should use a screw type clamp to seal the vent to the appliance air inlet and the air inlet cap. Proper sealing of the air inlet pipe ensures that combustion air will be free of contaminants and supplied in proper volume.

When a sidewall or vertical rooftop combustion air supply system is disconnected for any reason, the air inlet pipe must be resealed to ensure that combustion air will be free of contaminants and supplied in proper volume.

DANGER

Failure to properly seal all joints and seams as required in the air inlet piping may result in flue gas recirculation, spillage of flue products and carbon monoxide emissions causing severe personal injury or death.

3 General venting *(continued)*

Optional room air

Applications utilizing the Armor X2 water heater may be installed with a single pipe carrying the flue products to the outside while using combustion air from the equipment room. In order to use the room air venting option the following conditions and considerations must be followed.

- The unit **MUST** be installed with the appropriate room air kit (Table 3B).
- The equipment room **MUST** be provided with properly sized openings to assure adequate combustion air. Please refer to instructions provided with the room air kit.
- There will be a noticeable increase in the noise level during normal operation from the inlet air opening.
- Using the room air kit makes the unit vulnerable to combustion air contamination from within the building. Please review Section 1, Prevent Combustion Air Contamination, to ensure proper installation.
- Vent system and terminations must comply with the standard venting instructions set forth in this manual.

⚠ WARNING

When utilizing the single pipe method, provisions for combustion and ventilation air must be in accordance with Air for Combustion and Ventilation, of the latest edition of the National Fuel Gas Code, ANSI Z223.1, in Canada, the latest edition of CGA Standard B149 Installation Code for Gas Burning Appliances and Equipment, or applicable provisions of the local building codes.

Figure 3-5 Room Air Installation

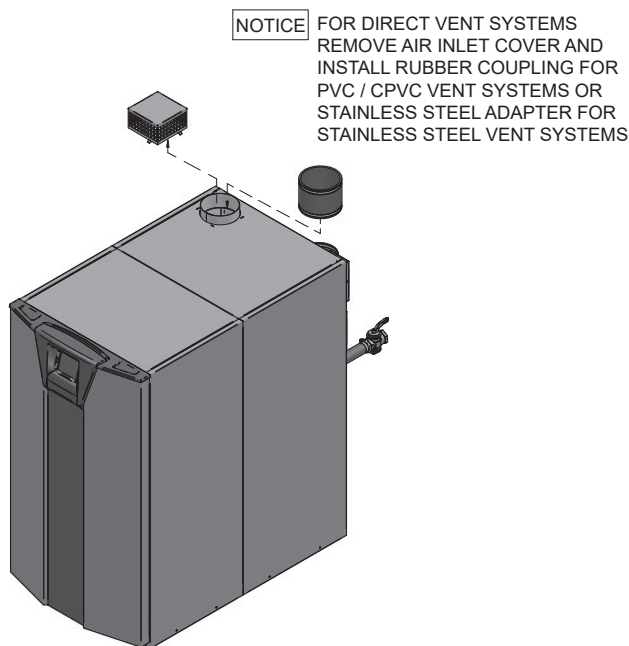

Table 3B Room Air Minimum / Maximum Allowable Air / Vent Lengths

Model	Vent Diameter	Vent Min. Length	Vent Max. Length	Input De-Rate per 25 feet of Vent
AW 1000	6"	12'	100'	0.63%*
AW 1300	6"	12'	100'	1.45%
AW 1500	6"	12'	100'	1.65%

*LP models will derate by .9% per 25 feet of vent pipe.

Air contamination

Pool and laundry products and common household and hobby products often contain fluorine or chlorine compounds. When these chemicals pass through the water heater, they can form strong acids. The acid can eat through the water heater wall, causing serious damage and presenting a possible threat of flue gas spillage or water heater water leakage into the building.

Please read the information given in Table 1A, page 10, listing contaminants and areas likely to contain them. If contaminating chemicals will be present near the location of the water heater combustion air inlet, have your installer pipe the water heater combustion air and vent to another location, per this manual.

⚠ WARNING

If the water heater combustion air inlet is located in a laundry room or pool facility, for example, these areas will always contain hazardous contaminants.

⚠ WARNING

To prevent the potential of severe personal injury or death, check for areas and products listed in Table 1A, page 10 before installing the water heater or air inlet piping.

If contaminants are found, you **MUST**:

- Remove contaminants permanently.
- OR—
- Relocate air inlet and vent terminations to other areas.

3 General venting

PVC/CPVC

This product has been approved for use with the PVC/CPVC vent materials listed in Table 3C.

Installing vent and air piping

WARNING For all installations, the first ten (10) equivalent feet of vent must be CPVC or stainless steel (see FIG. 3-6). The field provided vent fittings must be cemented to the CPVC pipe section using an “All Purpose Cement” suitable for PVC and CPVC pipe. Use only the vent materials, primer, and cement specified in Table 3C to make the vent connections. Failure to follow this warning could result in fire, personal injury, or death.

NOTICE Use only cleaners, primers, and solvents that are approved for the materials which are joined together.

NOTICE All PVC vent pipes must be glued, properly supported, and the exhaust must be pitched a minimum of a 1/4 inch per foot back to the water heater (to allow drainage of condensate).

WARNING Insulation should not be used on PVC or CPVC venting materials. The use of insulation will cause increased vent wall temperatures, which could result in vent pipe failure.

WARNING For all installations, the first ten (10) equivalent feet of vent must be CPVC or stainless steel (see FIG. 3-6). Failure to follow this warning could result in fire, personal injury, or death.

1. Work from the water heater to vent or air termination. Do not exceed the lengths given in this manual for the air or vent piping.
2. Cut pipe to the required lengths and deburr the inside and outside of the pipe ends.
3. Chamfer outside of each pipe end to ensure even cement distribution when joining.
4. Clean all pipe ends and fittings using a clean dry rag. (Moisture will retard curing and dirt or grease will prevent adhesion.)
5. Dry fit vent or air piping to ensure proper fit up before assembling any joint. The pipe should go a third to two-thirds into the fitting to ensure proper sealing after cement is applied.
6. Priming and Cementing:
 - a. Handle fittings and pipes carefully to prevent contamination of surfaces.
 - b. Apply a liberal even coat of primer to the fitting socket and to the pipe end to approximately 1/2" beyond the socket depth.
 - c. Apply a second primer coat to the fitting socket.
 - d. While primer is still wet, apply an even coat of approved cement to the pipe equal to the depth of the fitting socket along with an even coat of approved cement to the fitting socket.
 - e. Apply a second coat of cement to the pipe.
 - f. While the cement is still wet, insert the pipe into the fitting, if possible twist the pipe a 1/4 turn as you insert it. **NOTE:** If voids are present, sufficient cement was not applied and joint could be defective.
 - g. Wipe excess cement from the joint removing ring or beads as it will needlessly soften the pipe.

Table 3C PVC/CPVC Vent Pipe and Fittings

Approved PVC/CPVC Vent Pipe and Fittings		
Item	Material	Standard
Vent pipe	PVC Schedule 40, 80	ANSI/ASTM D1785
	PVC - DWV	ANSI/ASTM D2665
	CPVC Schedule 40, 80	ANSI/ASTM F441
Vent fittings	PVC Schedule 40	ANSI/ASTM D2466
	PVC Schedule 80	ANSI/ASTM D2467
	CPVC Schedule 80	ANSI/ASTM F439
	PVC - DWV	ANSI/ASTM D2665
Pipe Cement / Primer	PVC	ANSI/ASTM D2564
	CPVC	ANSI/ASTM F493

NOTICE: DO NOT USE CELLULAR (FOAM) CORE PIPE

NOTE: In Canada, CPVC and PVC vent pipe, fittings and cement/primer must be ULC-S636 certified.

Figure 3-6 Near Water Heater PVC/CPVC Venting

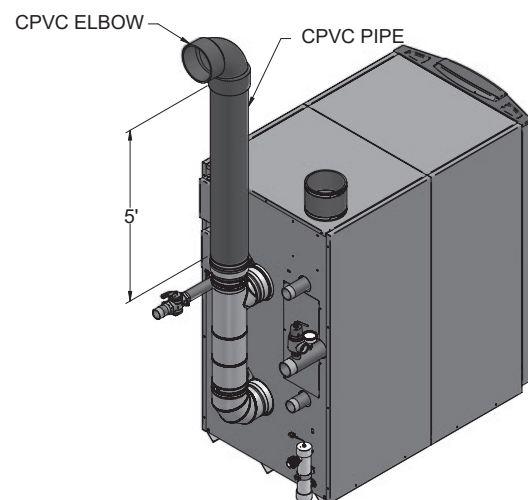

3 General venting *(continued)*

Polypropylene

This product has been approved for use with polypropylene vent with the manufacturers listed in Table 3D.

All terminations must comply with listed options in this manual and be a single-wall vent offering.

For use of flex pipe, it is recommended to have the vent material in 32°F or higher ambient space before bending at installation. No bends should be made to greater than 45° and ONLY installed in vertical or near vertical installations.

For support and special connections required, see the manufacturer's instructions. All vent is to conform to standard diameter and equivalent length requirements established.

WARNING

Use only the adapters and vent system listed in Tables 3E and 3F. DO NOT mix vent systems of different types or manufacturers. Failure to comply could result in severe personal injury, death, or substantial property damage.

NOTICE

Installations must comply with applicable national, state, and local codes. For Canadian installation, polypropylene vent must be listed as a ULC-S636 approved system.

NOTICE

Installation of a polypropylene vent system should adhere to the vent manufacturer's installation instructions supplied with the vent system.

Table 3D Polypropylene Vent Pipe and Fittings

Approved Polypropylene Vent Manufacturers	
Make	Model
Centrotherm Eco Systems	InnoFlue SW/Flex
Duravent (M & G Group)	PolyPro Single-Wall / PolyPro Flex

NOTICE

The installer must use a specific vent starter adapter at the flue collar connection, supplied by the vent manufacturer to adapt to its vent system. See Table 3E for approved vent adapters. Discard CPVC starter piece.

NOTICE

All vent connections MUST be secured by the vent manufacturer's joint connector (FIG. 3-7).

WARNING

Insulation should not be used on polypropylene venting materials. The use of insulation will cause increased vent wall temperatures, which could result in vent pipe failure.

Figure 3-7 Near Water Heater Polypropylene Venting

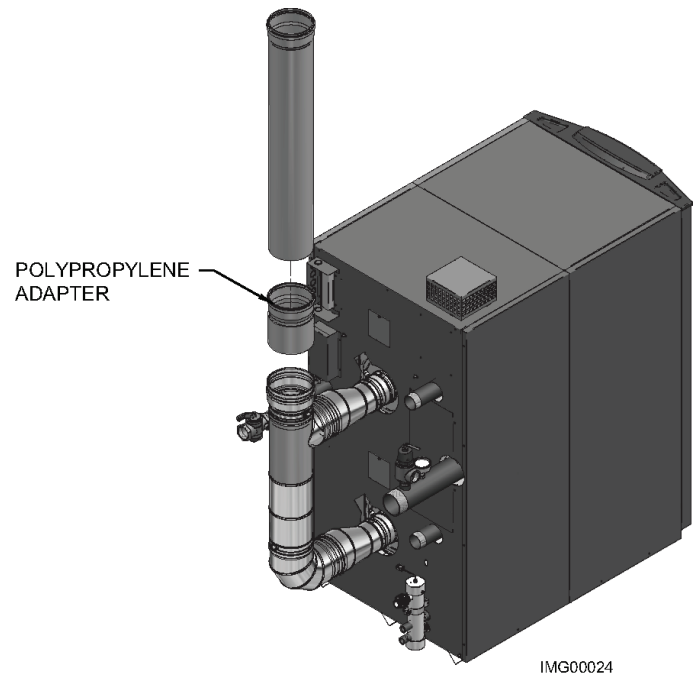

Table 3E Approved Polypropylene Terminations

Model	Centrotherm InnoFlue SW				Duravent Polypro		
	Polypropylene Adapter	Joint Connector	Sidewall Retaining Bracket*	Sidewall Adapter*	Polypropylene Adapter	Joint Connector	Sidewall Adapter*
1000 -1500	ISAAL0606	Not Required	IATP0606	ISTAGL0606	6PPS-06PVCM-6PPF	N/A	6PPK-HLK

* These parts are only needed if the sidewall termination assembly is used (see FIG. 4-5B on page 28).

3 General venting

Stainless steel vent

This product has been approved for use with stainless steel using FasNSeal vent systems. This unit requires Category IV venting.

WARNING Use only the materials, vent systems, and terminations listed in Table 3F. DO NOT mix vent systems of different types or manufacturers. Failure to comply could result in severe personal injury, death, or substantial property damage.

NOTICE The installer must use a specific vent starter adapter at the flue collar connection, supplied by the vent manufacturer to adapt to its vent system. See Table 3F for approved vent adapters. Discard CPVC starter piece.

NOTICE Installations must comply with applicable national, state, and local codes. Stainless steel vent systems must be listed as a UL-1738 approved system for the United States and a ULC-S636 approved system for Canada.

NOTICE Installation of a stainless steel vent system should adhere to the stainless steel vent manufacturer's installation instructions supplied with the vent system.

Figure 3-8 Near Water Heater Stainless Steel Venting

NOTICE PVC/CPVC or ABS is acceptable air inlet pipe material.

REMOVE PVC/CPVC VENT CONNECTOR WHEN INSTALLING STAINLESS STEEL

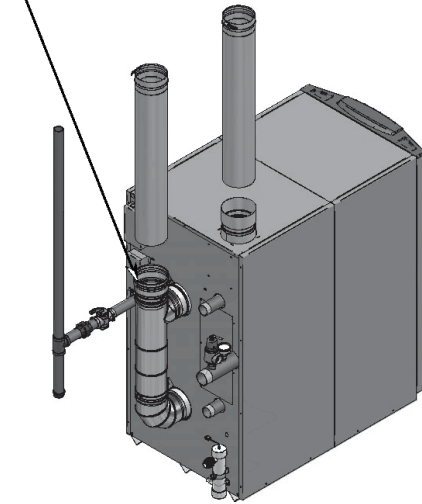

The Armor X2 uses model specific combustion air intake and vent piping sizes as detailed in Tables 3A and 3B.

NOTICE Increasing or decreasing combustion air or vent piping to sizes not specified in this manual is not authorized.

Table 3F Approved Stainless Steel Terminations and Adapters

STAINLESS STEEL VENT TERMINATION KITS			
Model	Kit Part Number	Component Description	
AW 1000 - 1500	100157602	6" PVC x 6" Stainless Steel Adapter	
		6" Stainless Steel Vent Termination	
		6" Stainless Steel Air Inlet	
AW 1300 - 1500	100157603	6" PVC x 6" Stainless Steel Adapter	
		6" Stainless Steel x 7" Stainless Steel Adapters (2)	
		7" Stainless Steel Vent Termination	
7" Stainless Steel Air Inlet			
METAL FAB			
Model	S.S. Adapter	Flue Termination	Intake Air Termination
AW 1000 - 1500	6FCGLXL	6FCGSWMC 6FCGSWC	6FCGSW90L
ICC			
AW 1000 - 1500	HE-6DSA-F	HE-6MC-F	HE-6E90-F HE-6SCR-F

4 Sidewall direct venting

Vent/air termination – sidewall

WARNING Follow instructions below when determining vent location to avoid possibility of severe personal injury, death, or substantial property damage.

WARNING A gas vent extending through an exterior wall shall not terminate adjacent to a wall or below building extensions such as eaves, parapets, balconies, or decks. Failure to comply could result in severe personal injury, death, or substantial property damage.

Determine location

Locate the vent/air terminations using the following guidelines:

- The total length of piping for vent or air must not exceed the limits given in the General Venting Section on page 17 of this manual.
- You must consider the surroundings when terminating the vent and air:
 - Position the vent termination where vapors will not damage nearby shrubs, plants or air conditioning equipment or be objectionable.
 - The flue products will form a noticeable plume as they condense in cold air. Avoid areas where the plume could obstruct window views.
 - Prevailing winds could cause freezing of condensate and water/ice buildup where flue products impinge on building surfaces or plants.
 - Avoid possibility of accidental contact of flue products with people or pets.
 - Do not locate the terminations where wind eddies could affect performance or cause recirculation, such as inside building corners, near adjacent buildings or surfaces, window wells, stairwells, alcoves, courtyards, or other recessed areas.

WARNING Sidewall vent and air inlet terminations must terminate in the same pressure zone.

- Do not terminate above any door or window. Condensate can freeze, causing ice formations.
- Locate or guard vent to prevent condensate damage to exterior finishes.
- Do not locate the terminations over public walkways.
- Do not locate the terminations near soffit vents, crawl space vents, or other areas where condensate or vapor could create a nuisance, hazard, or cause property damage.
- Do not locate the terminations where condensate vapor could cause damage or could be detrimental to the operation of regulators, relief valves, or other equipment.

Figure 4-1A PVC/CPVC/Centrotherm Sidewall Termination of Air and Vent

Note: Available in 6" diameter only.

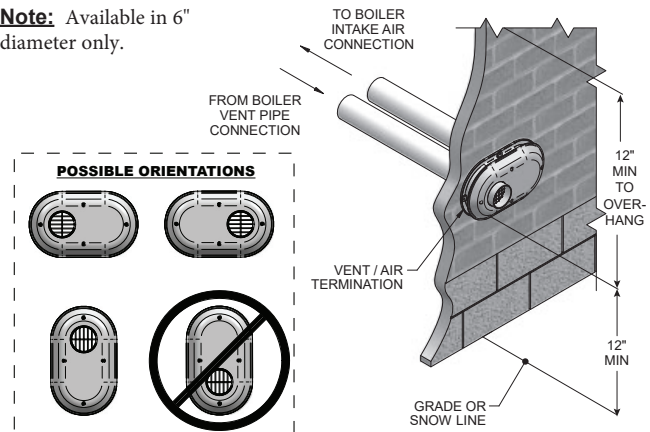

Table 4A CPVC/PVC Sidewall Vent Kits

Model	Kit Number	Vent Size
1.0 - 1.5	100157612	6 inch vent

If using the alternate sidewall termination:

- The air piping must terminate in a down-turned elbow as shown in FIG. 4-1B. This arrangement avoids recirculation of flue products into the combustion air stream.
- The vent piping must terminate in an elbow pointed outward or away from the air inlet, as shown in FIG. 4-1B.

WARNING Do not exceed the maximum lengths of the outside vent piping shown in FIG.'s 4-1B and 4-1C. Excessive length exposed to the outside could cause freezing of condensate in the vent pipe, resulting in potential water heater shutdown.

Figure 4-1B Alternate Sidewall Termination of Air and Vent w/Field Supplied Fittings

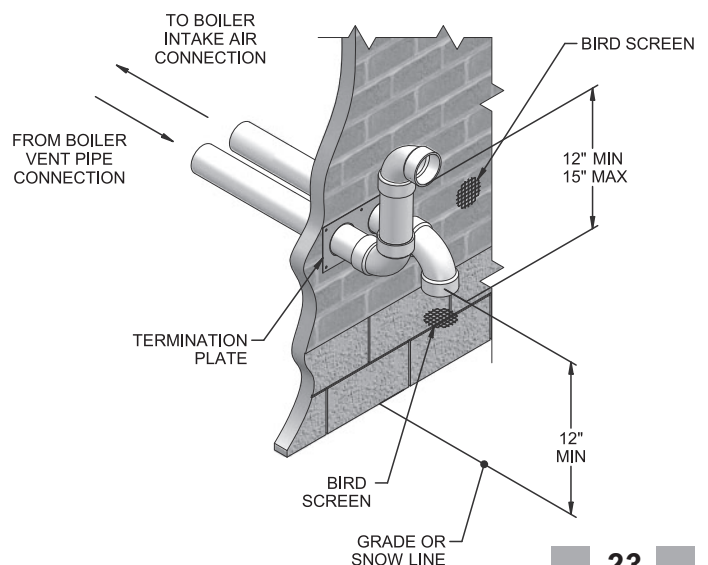

4 Sidewall direct venting

Vent/air termination – sidewall

Figure 4-1C Alternate Stainless Steel Sidewall Termination w/Field Supplied Fittings

NOTICE PVC/CPVC or ABS is acceptable air inlet pipe material.

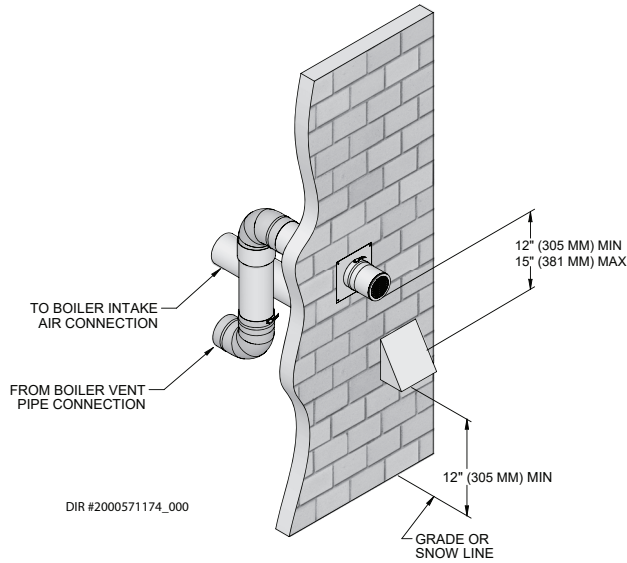

Figure 4-2A Clearance to Gravity Air Inlets

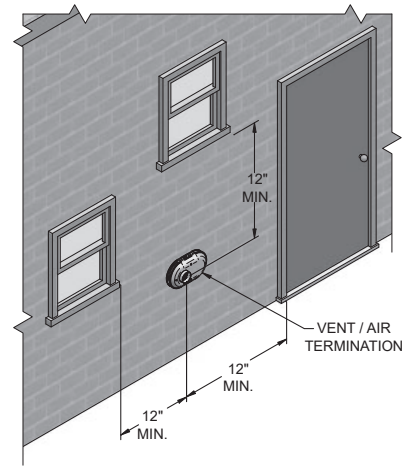

Figure 4-2B Alternate Clearance to Gravity Air Inlets with Field-Supplied Fittings

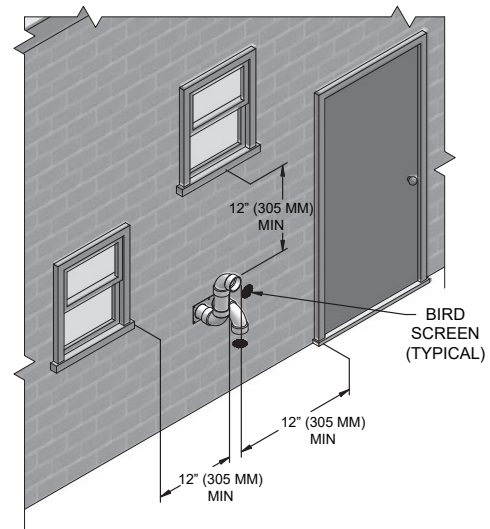

Table 4B Stainless Steel Sidewall Vent Kits

Model	Kit Number	Vent Size
1.0 - 1.5	100157602 (Stainless Steel)	6 inch vent
1.3 - 1.5	100157603 (Stainless Steel)	7 inch vent

5. Maintain clearances as shown in FIG.'s 4-1A thru 4-4B, pages 23 thru 28. Also maintain the following:
 - a. Vent must terminate:
 - At least 6 feet (1.8 m) from adjacent walls.
 - No closer than 12 inches (305 mm) below roof overhang.
 - b. Air inlet must terminate at least 12 inches (305 mm) above grade or snow line; at least 12 inches (305 mm) below the vent termination; and the vent pipe must not extend more than 24 inches (610 mm) vertically outside the building as shown in FIG.'s 4-1B and 4-1C.
 - c. Do not terminate closer than 4 feet (1.2 m) horizontally from any electric meter, gas meter, regulator, relief valve, or other equipment. Never terminate above or below any of these within 4 feet (1.2 m) horizontally.
6. Locate terminations so they are not likely to be damaged by foreign objects, such as stones or balls, or subject to buildup of leaves or sediment.

4 Sidewall direct venting *(continued)*

Figure 4-3A Direct Vent Terminal Clearances

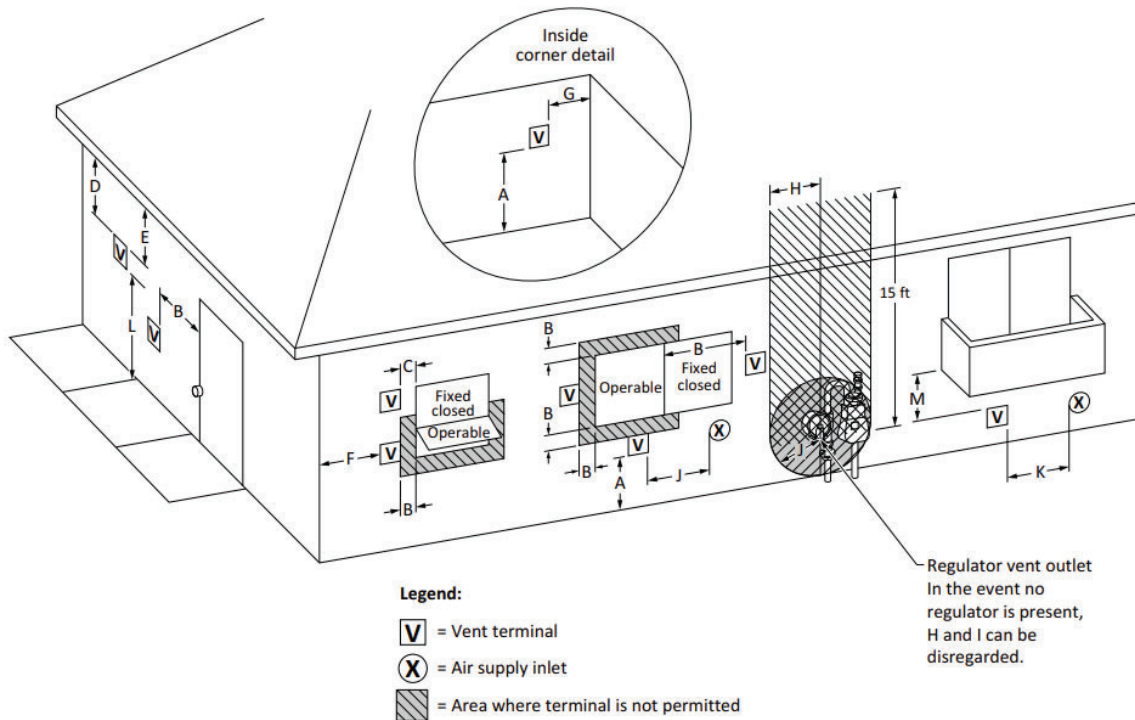

Table 4C Direct Vent Terminal Clearances

		Canadian Installations ¹	US Installations ²
A =	Clearance above grade, veranda, porch, deck, or balcony	12 in (30 cm)	12 in (30 cm)
B =	Clearance to window or door that may be opened	6 in (15 cm) for appliances ≤ 10,000 Btuh (3 kW), 12 in (30 cm) for appliances > 10,000 Btuh (3 kW) and ≤ 100,000 Btuh (30 kW), 36 in (91 cm) for appliances > 100,000 Btuh (30 kW)	6 in (15 cm) for appliances ≤ 10,000 Btuh (3 kW), 9 in (23 cm) for appliances > 10,000 Btuh (3 kW) and ≤ 50,000 Btuh (15 kW), 12 in (30 cm) for appliances > 50,000 Btuh (15 kW)
C =	Clearance to permanently closed window	*	*
D =	Vertical clearance to ventilated soffit located above the terminal within a horizontal distance of 2 ft (61 cm) from the center line of the terminal.	*	*
E =	Clearance to unventilated soffit	*	*
F =	Clearance to outside corner	*	*
G =	Clearance to inside corner	*	*
H =	Clearance to each side of center line extended above meter / regulator assembly	3 ft (91 cm) within a height 15 ft (4.6 m)	*
I =	Clearance to service regulator vent outlet	3 ft (91 cm)	*

4 Sidewall direct venting

Table 4C Direct Vent Terminal Clearances (continued)

J =	Clearance to nonmechanical air supply inlet to building or the combustion air inlet to any other appliance	6 in (15 cm) for appliances \leq 10,000 Btuh (3kW), 12 in (30 cm) for appliances $>$ 10,000 Btuh (3 kW) and \leq 100,000 Btuh (30 kW), 36 in (91 cm) for appliances $>$ 100,000 Btuh (30 kW)	6 in (15 cm) for appliances \leq 10,000 Btuh (3kW), 9 in (23 cm) for appliances $>$ 10,000 Btuh (3 kW) and \leq 50,000 Btuh (15 kW), 12 in (30 cm) for appliances $>$ 50,000 Btuh (15 kW)
K =	Clearance to a mechanical air supply inlet	6 ft (1.83 m)	3 ft (91 cm) above if within 10 ft (3 m) horizontally
L =	Clearance above paved sidewalk or paved driveway located on public property	7 ft (2.13 m)†	7 ft (2.13 m) for mechanical draft systems (Category I appliances). Vents for Category II and IV appliances cannot be located above public walkways or other areas where condensate or vapor can cause a nuisance or hazard
M =	Clearance under veranda, porch, deck, or balcony	12 in (30 cm)‡	*
<p>* Clearance in accordance with local installation codes and the requirements of the gas supplier.</p> <p>† A vent shall not terminate directly above a sidewalk or paved driveway that is located between two single family dwellings and serves both dwellings.</p> <p>‡ Permitted only if veranda, porch, deck, or balcony is fully open on a minimum of two sides beneath the floor.</p> <p>NOTES:</p> <p>1) In accordance with the current CSA B149.1, Natural Gas and Propane Installation Code</p> <p>2) In accordance with the current ANSI Z223.1/NFPA 54, National Fuel Gas Code</p>			

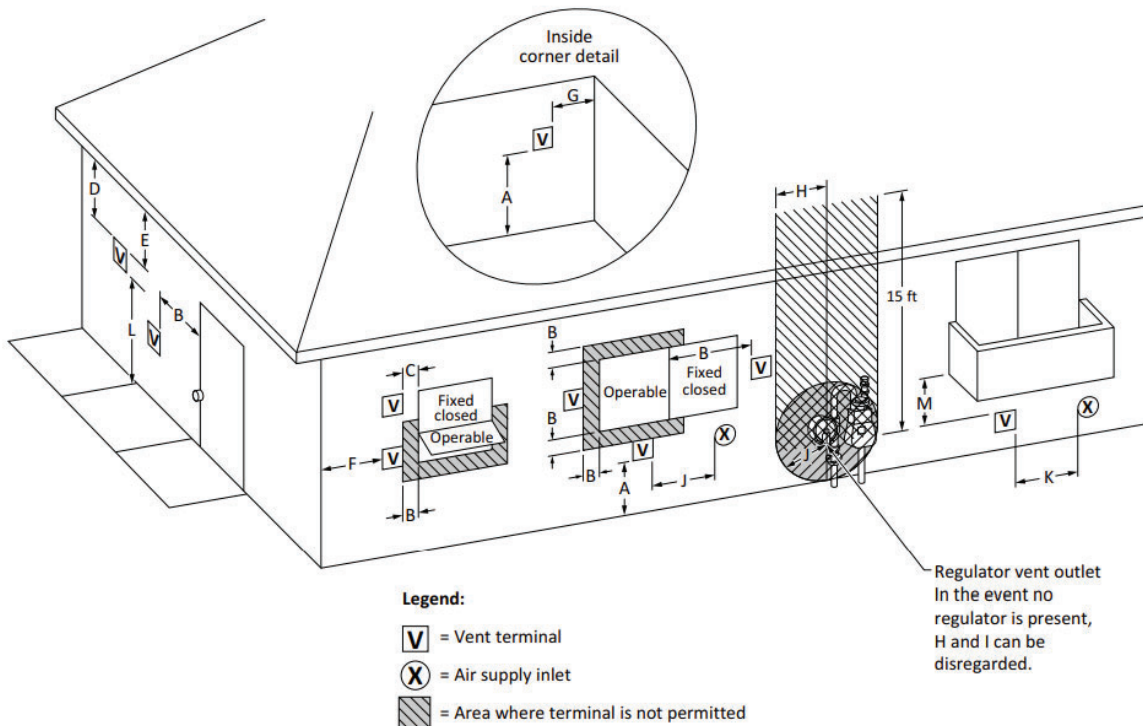
Figure 4-3B Other than Direct Vent Terminal Clearances

4 Sidewall direct venting *(continued)*

Table 4D Other than Direct Vent Terminal Clearances

		Canadian Installations ¹	US Installations ²
A =	Clearance above grade, veranda, porch, deck, or balcony	12 in (30 cm)	12 in (30 cm)
B =	Clearance to window or door that may be opened	6 in (15 cm) for appliances ≤ 10,000 Btuh (3 kW), 12 in (30 cm) for appliances > 10,000 Btuh (3 kW) and ≤ 100,000 Btuh (30 kW), 36 in (91 cm) for appliances > 100,000 Btuh (30 kW)	4 ft (1.2 m) below or to side of opening; 1 ft (300 mm) above opening
C =	Clearance to permanently closed window	*	*
D =	Vertical clearance to ventilated soffit located above the terminal within a horizontal distance of 2 ft (61 cm) from the center line of the terminal.	*	*
E =	Clearance to unventilated soffit	*	*
F =	Clearance to outside corner	*	*
G =	Clearance to inside corner	*	*
H =	Clearance to each side of center line extended above meter / regulator assembly	3 ft (91 cm) within a height 15 ft (4.6 m)	*
I =	Clearance to service regulator vent outlet	3 ft (91 cm)	*
J =	Clearance to nonmechanical air supply inlet to building or the combustion air inlet to any other appliance	6 in (15 cm) for appliances ≤ 10,000 Btuh (3kW), 12 in (30 cm) for appliances > 10,000 Btuh (3 kW) and ≤ 100,000 Btuh (30 kW), 36 in (91 cm) for appliances > 100,000 Btuh (30 kW)	4 ft (1.2 m) below or to side of opening; 1 ft (300 mm) above opening
K =	Clearance to a mechanical air supply inlet	6 ft (1.83 m)	3 ft (91 cm) above if within 10 ft (3 m) horizontally
L =	Clearance above paved sidewalk or paved driveway located on public property	7 ft (2.13 m)†	7 ft (2.13 m) for mechanical draft systems (Category I appliances). Vents for Category II and IV appliances cannot be located above public walkways or other areas where condensate or vapor can cause a nuisance or hazard
M =	Clearance under veranda, porch, deck, or balcony	12 in (30 cm)‡	*

* Clearance in accordance with local installation codes and the requirements of the gas supplier.

† A vent shall not terminate directly above a sidewalk or paved driveway that is located between two single family dwellings and serves both dwellings.

‡ Permitted only if veranda, porch, deck, or balcony is fully open on a minimum of two sides beneath the floor.

NOTES:

- 1) In accordance with the current CSA B149.1, Natural Gas and Propane Installation Code
- 2) In accordance with the current ANSI Z223.1/NFPA 54, National Fuel Gas Code

4 Sidewall direct venting

Prepare wall penetrations

- Use the factory supplied wall plate as a template to locate the vent and air intake holes and mounting holes.

Air pipe penetration:

- Cut a hole for the air pipe. Size the air pipe hole as close as desired to the air pipe outside diameter.

Vent pipe penetration:

- Cut a hole for the vent pipe. For either combustible or noncombustible construction, size the vent pipe hole with at least a 1/2 inch clearance around the vent pipe outer diameter:
 - 7½ inch hole for 6 inch vent pipe
 - 8½ inch hole for 7 inch vent pipe

Drill 3/16" diameter holes for inserting the plastic anchors into the wall.

- For Polypropylene Only: Install the vent and air intake sidewall adapters from Table 3E on page 21 into the vent plate. Slide the sidewall retaining bracket down the sidewall adapters flush to the vent plate (FIG. 4-5B).
- For PVC/CPVC Only: Install the vent and air intake piping through the wall into the vent plate openings. Use RTV silicone sealant to seal the air pipe. Use the cement/primer listed in Table 3C on page 20 to seal the vent pipe.
- Mount and secure the vent plate to the wall, using stainless steel screws.
- Seal all gaps between the pipes and wall. Seal around the plate to the wall assuring no air gaps.
- Assemble the vent cap to the vent plate (see FIG.'s 4-5A and 4-5B). Insert the stainless steel screws into the vent cap screw hole openings and securely attach the vent cap to the vent plate.
- Seal all wall cavities.

- PVC/CPVC terminations are designed to accommodate any wall thickness of standard constructions per the directions found in this manual.
- Stainless steel terminations are designed to penetrate walls with a thickness up to 9.25 inches of standard construction.

Figure 4-4A PVC/CPVC Sidewall Termination Assembly

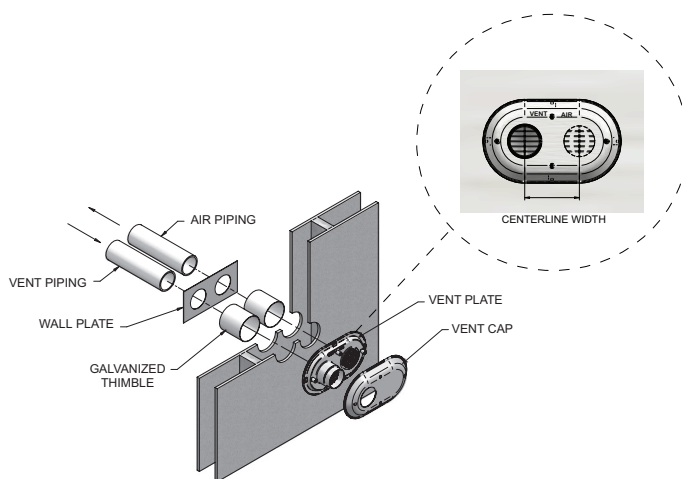
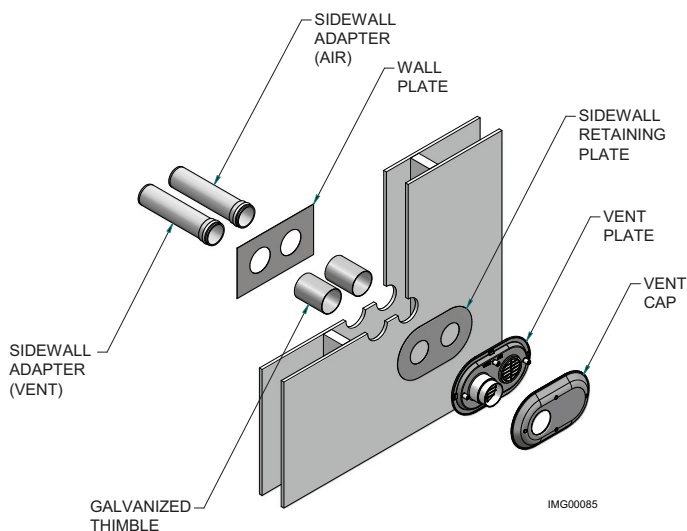

Table 4E Sidewall Vent Centerline Dimensions

Model	Air	Vent	Centerline Width
All	6"	6"	7 3/4"

Figure 4-4B Polypropylene Sidewall Termination Assembly



IMG00085

4 Sidewall direct venting *(continued)*

Prepare wall penetrations (Alternate Field Supplied Options)

1. Air pipe penetration:
 - a. Cut a hole for the air pipe. Size the air pipe hole as close as desired to the air pipe outside diameter.
2. Vent pipe penetration:
 - a. Cut a hole for the vent pipe. For either combustible or noncombustible construction, size the vent pipe hole with at least a 1/2 inch clearance around the vent pipe outer diameter:
 - 7½ inch (178 mm) hole for 6 inch (152 mm) vent pipe
 - 8½ inch (203 mm) hole for 7 inch (178 mm) vent pipe
 - b. Insert a galvanized metal thimble in the vent pipe hole (when required by local codes) (FIG. 4-5C).
3. Use a sidewall termination plate as a template for correct location of hole centers.
4. Follow all local codes for isolation of vent pipe when passing through floors or walls.
5. Seal exterior openings thoroughly with exterior caulk.

Figure 4-5C Alternate Sidewall Termination Assembly PVC/CPVC or Stainless Steel

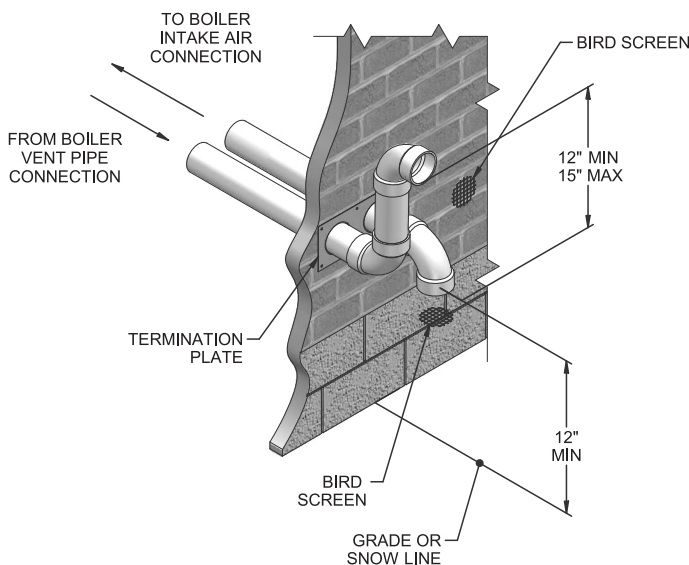

Multiple vent/air terminations

1. When terminating multiple Armor X2 water heaters terminate each vent/air connection as described in this manual (FIG. 4-6A).

WARNING All vent pipes and air inlets must terminate at the same height to avoid possibility of severe personal injury, death, or substantial property damage.

2. Place wall penetrations to obtain minimum clearance of 12 inches (305 mm) between vent pipe and adjacent air inlet elbow, as shown in FIG. 4-6A for U.S. installations. For Canadian installations, provide clearances required by CSA B149.1 Installation Code.
3. The air inlet of an Armor X2 is part of a direct vent connection. It is not classified as a forced air intake with regard to spacing from adjacent water heater vents.

Figure 4-6A Multiple Vent Terminations (must also comply with Figure 4-1A)

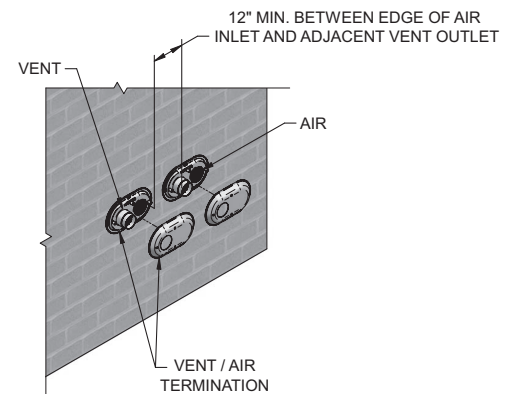
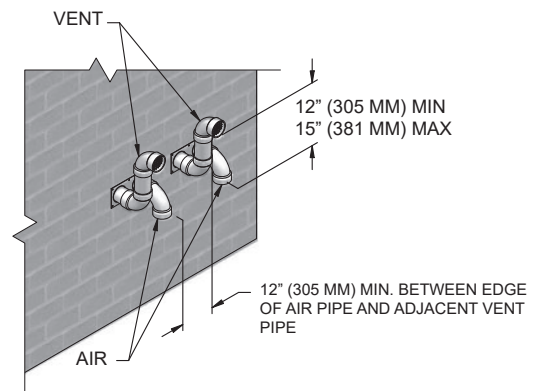

Figure 4-6B Alternate Multiple Vent Terminations w/Field Supplied Fittings (must also comply with Figure 4-1B)



5 Vertical direct venting

Vent/air termination – vertical

WARNING Follow instructions below when determining vent location to avoid possibility of severe personal injury, death, or substantial property damage.

Determine location

Locate the vent/air terminations using the following guidelines:

1. The total length of piping for vent or air must not exceed the limits given in the General Venting Section on page 17 of this manual.
2. Prepare the vent termination and the air termination elbow (FIG. 5-1A) by inserting bird screens. Bird screens should be obtained locally.
3. The vent must terminate at least 3 feet above the highest place in which the vent penetrates the roof and at least 2 feet above any part of a building within 10 horizontal feet.
4. The air piping must terminate in a down-turned 180° return pipe no further than 2 feet from the center of the vent pipe. This placement avoids recirculation of flue products into the combustion air stream.
5. The vent piping must terminate in an up-turned coupling as shown in FIG. 5-1A. The top of the coupling must be at least 1 foot above the air intake. When the vent termination uses a rain cap as illustrated in FIG. 5-1B maintain at least 36" (914 mm) above the air inlet. The air inlet pipe and vent pipe can be located in any desired position on the roof, but must always be no further than 2 feet (.6 m) apart and with the vent termination at least 1 foot for PVC and 3 feet for stainless steel, above the air intake.
6. Maintain the required dimensions of the finished termination piping as shown in FIG. 5-1A.
7. Do not extend exposed vent pipe outside of building more than shown in this document. Condensate could freeze and block vent pipe.

WARNING Rooftop vent and air inlet terminations must terminate in the same pressure zone, unless vertical vent sidewall air is set up as shown in the General Venting - Vertical Vent, Sidewall Air Section.

Figure 5-1 PVC/CPVC/Polypropylene Vertical Termination of Air and Vent

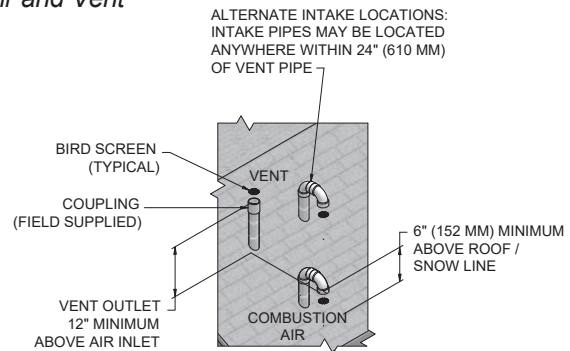
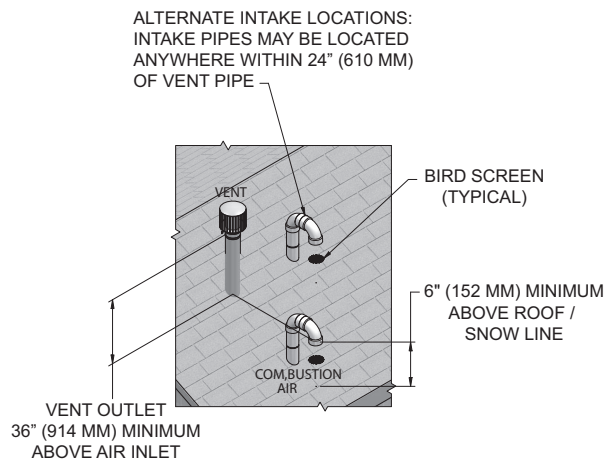

Figure 5-2 Stainless Steel Vertical Termination of Air and Vent



5. Locate terminations so they are not likely to be damaged by foreign objects, such as stones or balls, or subject to buildup of leaves or sediment.

Prepare roof penetrations

1. Air pipe penetration:
 - a. Cut a hole for the air pipe. Size the air pipe hole as close as desired to the air pipe outside diameter.
2. Vent pipe penetration:
 - a. Cut a hole for the vent pipe. For either combustible or noncombustible construction, size the vent pipe hole with at least a 1/2 inch clearance around the vent pipe outer diameter:
 - 7½ inch (178 mm) hole for 6 inch (152 mm) vent pipe
 - 8½ inch (203 mm) hole for 7 inch (178 mm) vent pipe
 - b. Insert a galvanized metal thimble in the vent pipe hole (when required by local codes).
3. Space the air and vent holes to provide the minimum spacing shown in FIG.'s 5-1 and 5-2.
4. Follow all local codes for isolation of vent pipe when passing through floors, ceilings, and roofs.
5. Provide flashing and sealing boots sized for the vent pipe and air pipe.

5 Vertical direct venting *(continued)*

Multiple vent/air terminations

1. When terminating multiple Armor X2 water heaters, terminate each vent/air connection as described in this manual (FIG. 5-3).

WARNING Terminate all vent pipes at the same height and all air pipes at the same height to avoid recirculation of flue products and the possibility of severe personal injury, death, or substantial property damage.

2. Place roof penetrations to obtain minimum clearance of 12 inches (305 mm) between edge of air intake elbow and adjacent vent pipe of another water heater for U.S. installations (see FIG. 5-3). For Canadian installations, provide clearances required by CSA B149.1 Installation Code.
3. The air inlet of an Armor X2 water heater is part of a direct vent connection. It is not classified as a forced air intake with regard to spacing from adjacent water heater vents.

Figure 5-3 Vertical Terminations with Multiple Water Heaters

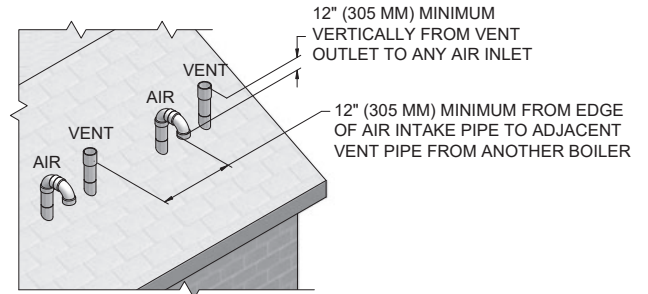
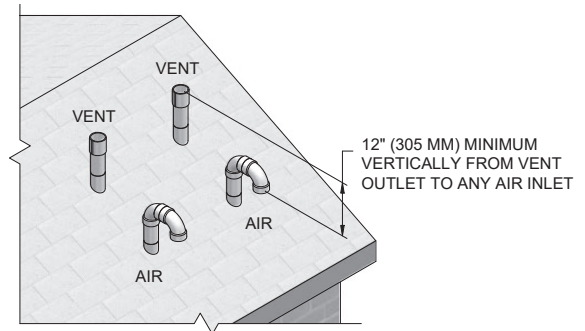

Figure 5-4 Alternate Vertical Terminations with Multiple Water Heaters



6 System piping

System water piping methods

Observe a minimum of 1/4 inch clearance around all un-insulated hot water pipes when openings around the pipes are not protected by non-combustible materials.

General piping information

Basic steps are listed below along with illustrations on the following pages (FIG.'s 6-2 thru 6-6), which will guide you through the installation of the Armor X2 water heater.

1. Connect the cold water supply to the inlet side of the water heater.
2. Connect the hot water supply to the outlet side of the water heater.
3. Install a backflow preventer on the cold feed make-up water line.
4. Install the factory supplied pump as shown in FIG.'s 6-2 thru 6-6.
5. Install an expansion tank on the system supply. Consult the tank manufacturer's instruction for specific information relating to tank installation. Size the expansion tank for the required system volume and capacity.
6. Install a drain valve at the lowest point of the system.
7. This appliance is supplied with a relief valve sized in accordance with ASME Boiler and Pressure Vessel Code, Section IV ("Heating Boilers"). Pipe the discharge of the safety relief valve to a suitable drain to prevent injury in the event of pressure relief. Pipe the discharge to a drain. Provide piping that is the same size as the safety relief valve outlet. Never block the outlet of the safety relief valve.

See the *piping illustrations included in this section, FIG.'s 6-2 thru 6-6 for suggested guidelines in piping the Armor X2 water heater.

NOTICE

*Please note that these illustrations are meant to show system piping concept only, the installer is responsible for all equipment and detailing required by local codes.

Scalding

This water heater can deliver scalding temperature water at any faucet in the system. Be careful whenever using hot water to avoid scalding injury. Certain appliances such as dishwashers and automatic clothes washers may require increased temperature water. By setting the thermostat on this water heater to obtain the increased temperature water required by these appliances, you may create the potential for scald injury. To protect against injury, you should install a mixing valve in the water system. This valve will reduce point of discharge temperature by mixing cold and hot water in branch supply lines. Such valves are available from the local plumbing supplier.

Figure 6-1 Scald Warning Label Located on the Appliance

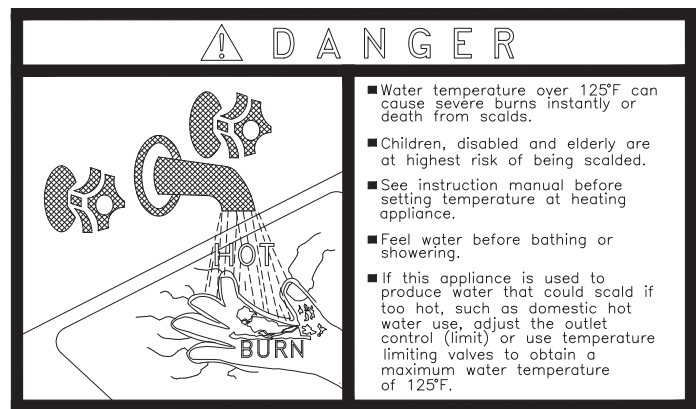

The following chart (Table 6A) details the relationship of water temperature and time with regard to scald injury and may be used as a guide in determining the safest water temperature for your applications.

Table 6A Approximate Time / Temperature Scald Chart

APPROXIMATE TIME / TEMPERATURE RELATIONSHIPS IN SCALDS	
120°F	More than 5 minutes
125°F	1 1/2 to 2 minutes
130°F	About 30 seconds
135°F	About 10 seconds
140°F	Less than 5 seconds
145°F	Less than 3 seconds
150°F	About 1 1/2 seconds
155°F	About 1 second

6 System piping *(continued)*

Water chemistry

NOTICE

The temperature rises and circulating pumps shown in Table 6B are selected based on the heating of potable water with a specified water chemistry. See Table 10A in Start-Up Section for recommendations.

Heating of high hardness and/or high total dissolved solids water may require a larger circulating pump, and a revised temperature rise specification based on the water chemistry of the water to be heated. See Table 10A in Start-Up Section for recommendations.

Water with a hardness of less than 5 grains per gallon will usually have a pH which can be aggressive and corrosive causing non-warrantable damage to the pump, and associated piping. Corrosion due to water chemistry generally shows up first in the hot water system because heated water increases the rate of corrosive chemical reactions.

Piping components

Water heater system piping:

Water heater system piping MUST be sized per the pipe requirements listed in Table 6B. Reducing the pipe size can restrict the flow rate through the water heater, causing inadvertent high limit shutdowns and poor system performance.

Check valves:

Field supplied. Check valves are recommended for installation as shown in FIG.'s 6-2 thru 6-6.

Water heater isolation valves:

Field supplied. Full port ball valves are required. Failure to use full port ball valves could result in a restricted flow rate through the water heater.

Anti-scald mixing valve:

Field supplied. An anti-scald mixing valve is recommended when storing domestic hot water above 115°F.

Unions:

Field supplied. Recommended for unit serviceability.

Temperature and pressure relief valve:

Factory supplied on water heaters. The temperature and pressure relief valve is sized to ASME specifications. Storage tanks may require additional valves depending on local codes.

Tank sensor:

Lochinvar supplies a tank sensor. The tank sensor MUST be installed in the lower 25% of the storage tank to achieve proper operation. As shipped from the factory, the tank sensor is in the literature package shipped with the unit.

Strainer:

Field supplied. Required to help eliminate debris from causing damage to the heat exchanger. When installing in a pre-existing system, it is recommended to install a filter in the recirculation line capable of removing debris left in the system.

Table 6B Water Heater Pump Applications / Typical Temperature Rise

Water Heater Pump Applications							
Model	*Pipe Size		Water Hardness	Grundfos	**Flow Rate (GPM)	Loss (FT/HD)	Temp. Rise
	Inlet	Outlet					
1.0	2"(2x)	3"	5 to 12 gpg	***UP 43-110 SF	100	26	22°F
			12 to 15 gpg	TP 40-240	132	43	17°F
1.3	2"(2x)	3"	5 to 12 gpg	***TP 40-160	125	32	22°F
			12 to 15 gpg	TP 50-160/2B	150	46	17°F
1.5	2"(2x)	3"	5 to 12 gpg	***TP 40-160	130	31	24°F
			12 to 15 gpg	TP 50-160/2B	170	43	18°F

***Note:** Pump selections and flow shown above are based on 45 feet of 3" minimum piping, 4 - 90° elbows, and 2 - fully ported ball valves.

****Note:** This appliance is shipped with two pumps to meet the flow requirements listed above.

*****Note:** Denotes standard pump supplied with unit.

6 System piping

Figure 6-2 Single Heater - Single Tank (2 Temperature)

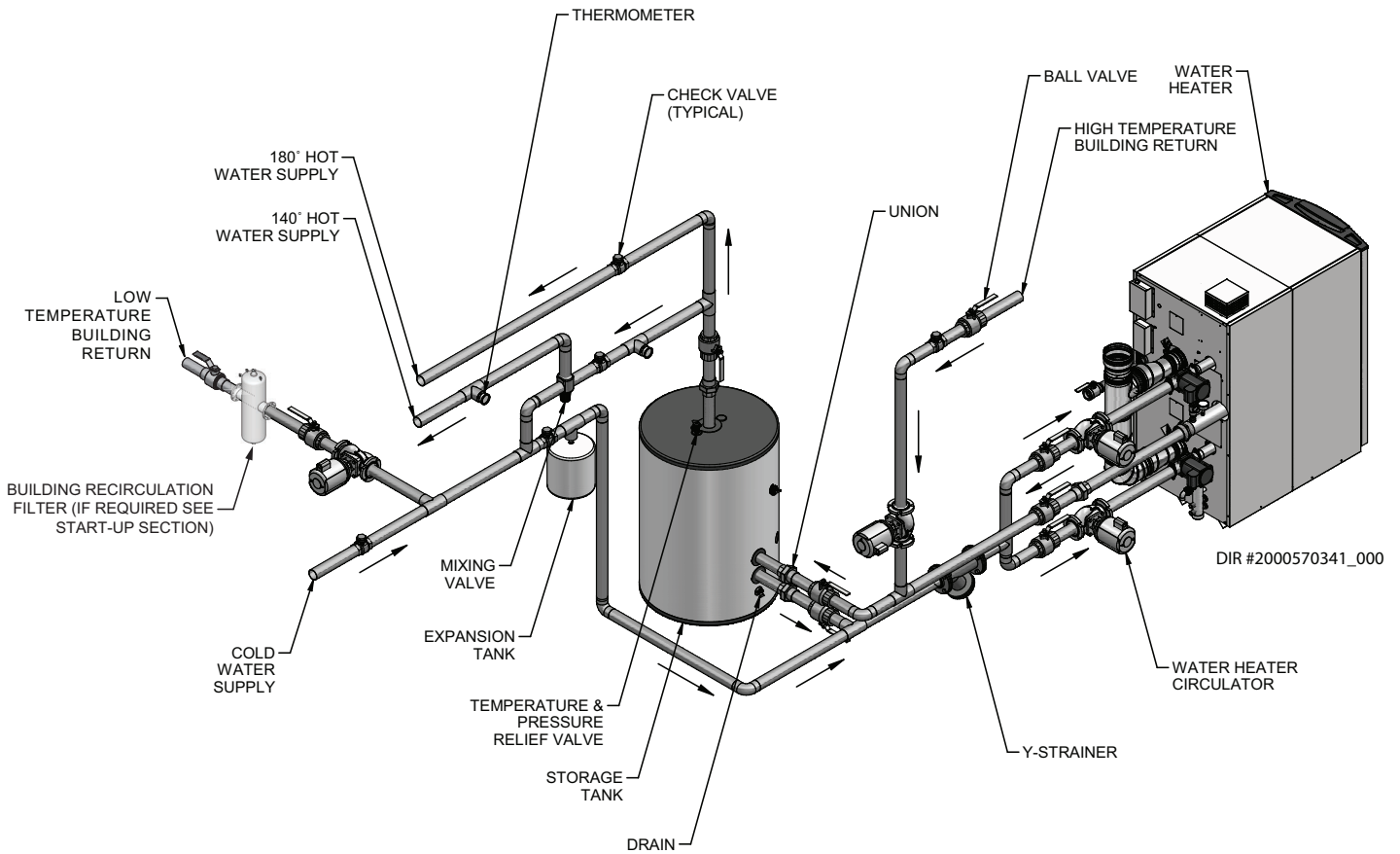

CAUTION

The piping will not support the weight of the water heater circulator pump. Do not attempt to support the weight of the water heater circulator pump with the piping or its accessories. Refer to the pump manufacturer's installation instructions. Failure to comply could result in severe personal injury, death, or substantial property damage.

NOTICE

Please note that these illustrations are meant to show system piping concept only, the installer is responsible for all equipment. The installer must follow all manufacturer's instructions for each system component. The installer is responsible for compliance with local codes.

6 System piping *(continued)*

Figure 6-3 Single Heater - Single Tank

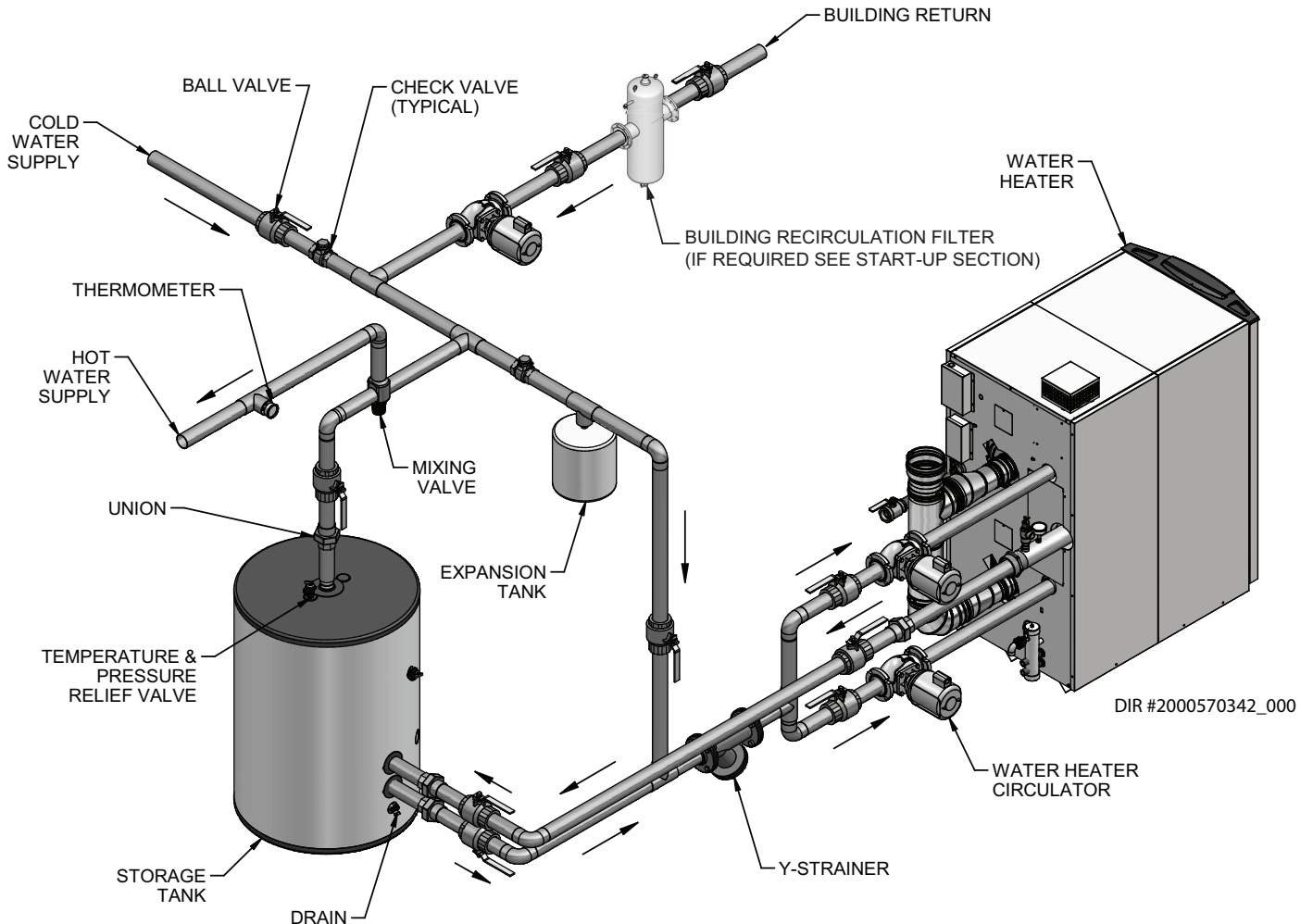

CAUTION

The piping will not support the weight of the water heater circulator pump. Do not attempt to support the weight of the water heater circulator pump with the piping or its accessories. Refer to the pump manufacturer's installation instructions. Failure to comply could result in severe personal injury, death, or substantial property damage.

NOTICE

Please note that these illustrations are meant to show system piping concept only, the installer is responsible for all equipment. The installer must follow all manufacturer's instructions for each system component. The installer is responsible for compliance with local codes.

6 System piping

Figure 6-4 Single Heater - Double Tank

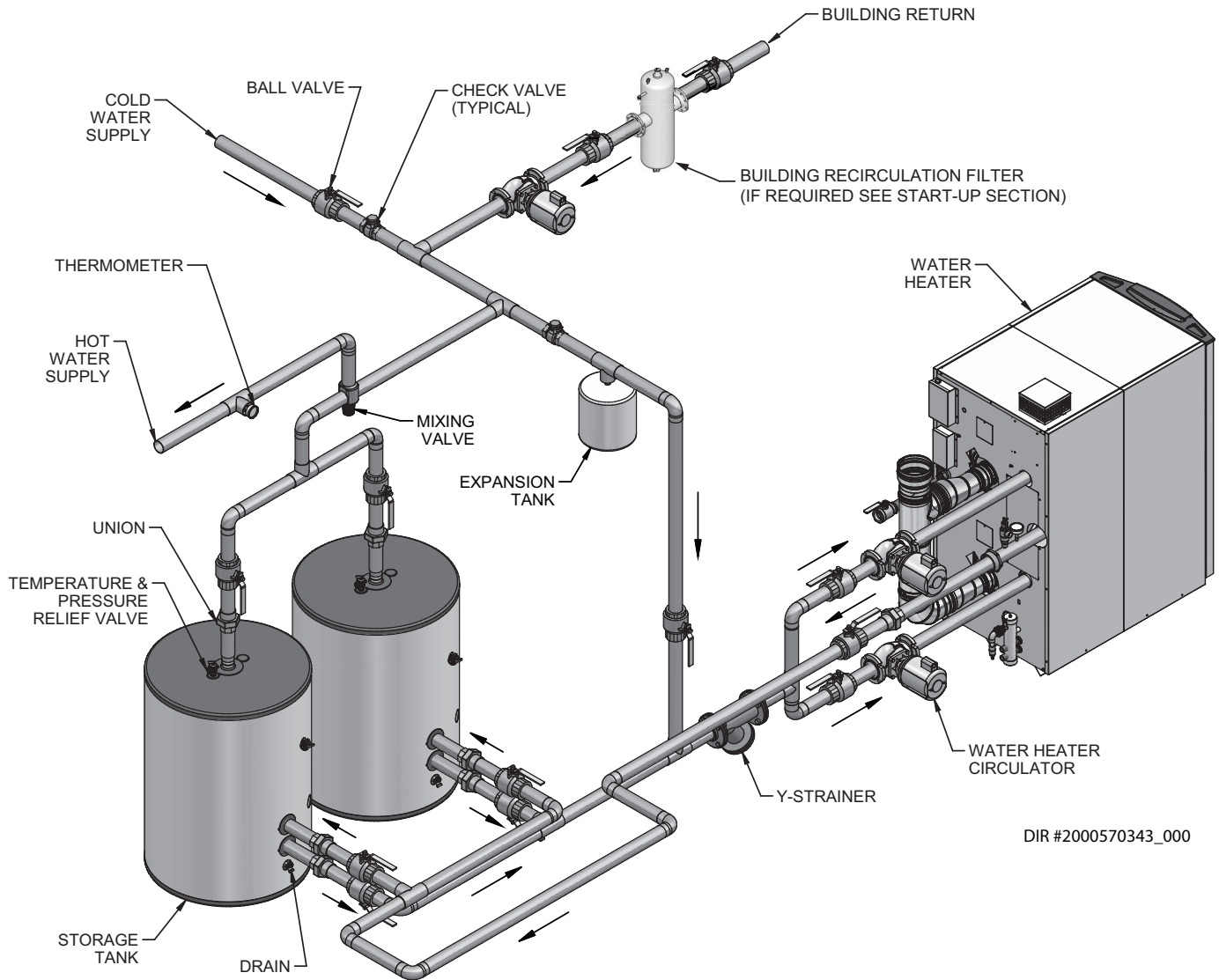

DIR #2000570343_000

CAUTION The piping will not support the weight of the water heater circulator pump. Do not attempt to support the weight of the water heater circulator pump with the piping or its accessories. Refer to the pump manufacturer's installation instructions. Failure to comply could result in severe personal injury, death, or substantial property damage.

NOTICE Please note that these illustrations are meant to show system piping concept only, the installer is responsible for all equipment. The installer must follow all manufacturer's instructions for each system component. The installer is responsible for compliance with local codes.

6 System piping *(continued)*

Figure 6-5 Double Heater - Single Tank

Model	Number of Units							Model	Number of Units						
	2	3	4	5	6	7	8		2	3	4	5	6	7	8
	Required Pipe Sizes in NPT with Standard Pump								Required Pipe Sizes in NPT with Upsized Pump						
1.0	4"	5"	6"	6"	8"	8"	8"	1.0	4"	5"	6"	8"	8"	8"	8"
1.3	5"	6"	6"	6"	8"	8"	8"	1.3	5"	6"	6"	8"	8"	8"	10"
1.5	5"	6"	6"	8"	8"	8"	8"	1.5	5"	6"	8"	8"	8"	10"	10"

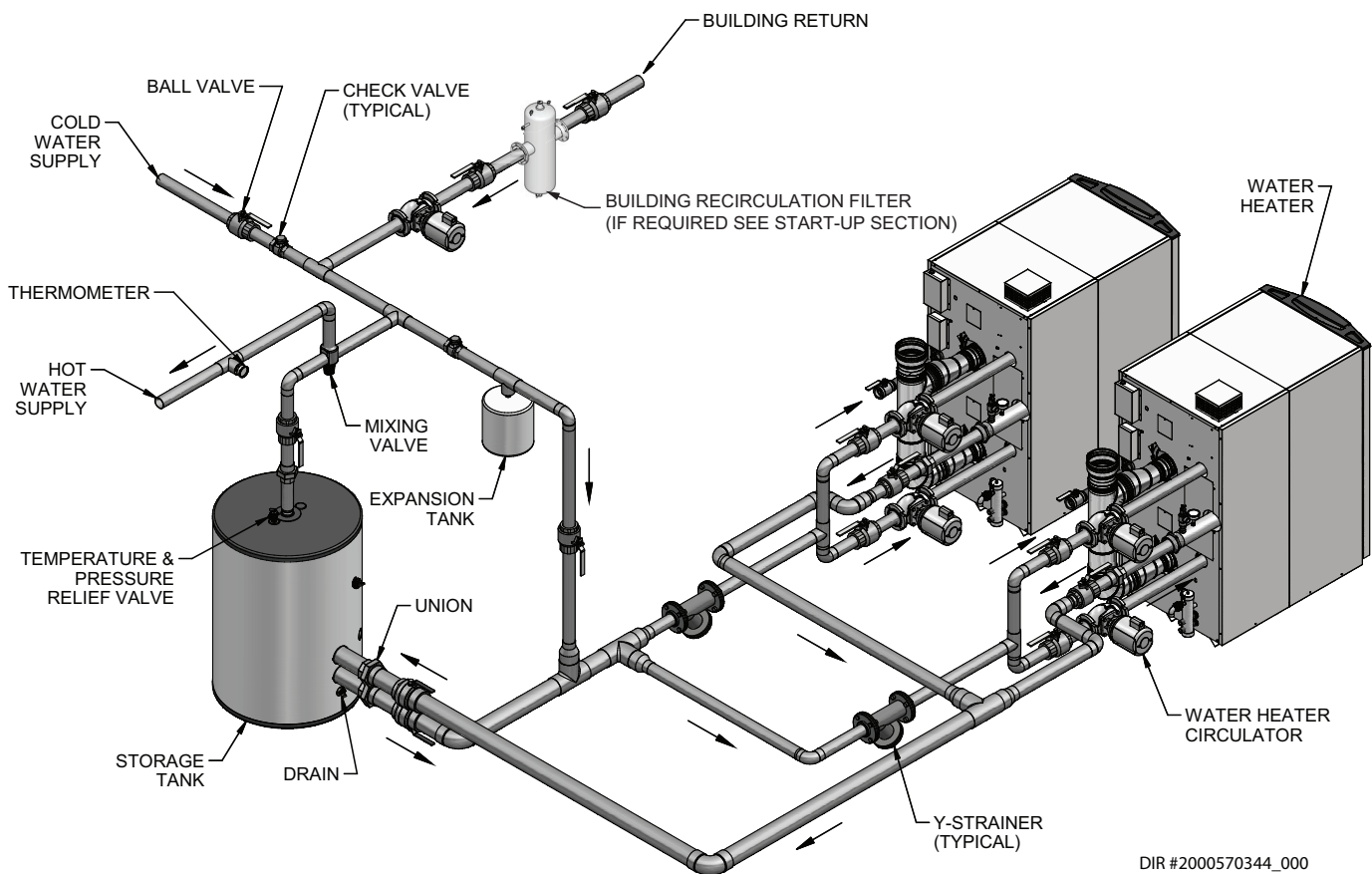

CAUTION

The piping will not support the weight of the water heater circulator pump. Do not attempt to support the weight of the water heater circulator pump with the piping or its accessories. Refer to the pump manufacturer's installation instructions. Failure to comply could result in severe personal injury, death, or substantial property damage.

NOTICE

Please note that these illustrations are meant to show system piping concept only, the installer is responsible for all equipment. The installer must follow all manufacturer's instructions for each system component. The installer is responsible for compliance with local codes.

6 System piping

Figure 6-6 Double Heater - Double Tank

Model	Number of Units							Model	Number of Units						
	2	3	4	5	6	7	8		2	3	4	5	6	7	8
	Required Pipe Sizes in NPT with Standard Pump														
1.0	4"	5"	6"	6"	8"	8"	8"	1.0	4"	5"	6"	8"	8"	8"	8"
1.3	5"	6"	6"	6"	8"	8"	8"	1.3	5"	6"	6"	8"	8"	8"	10"
1.5	5"	6"	6"	8"	8"	8"	8"	1.5	5"	6"	8"	8"	8"	10"	10"

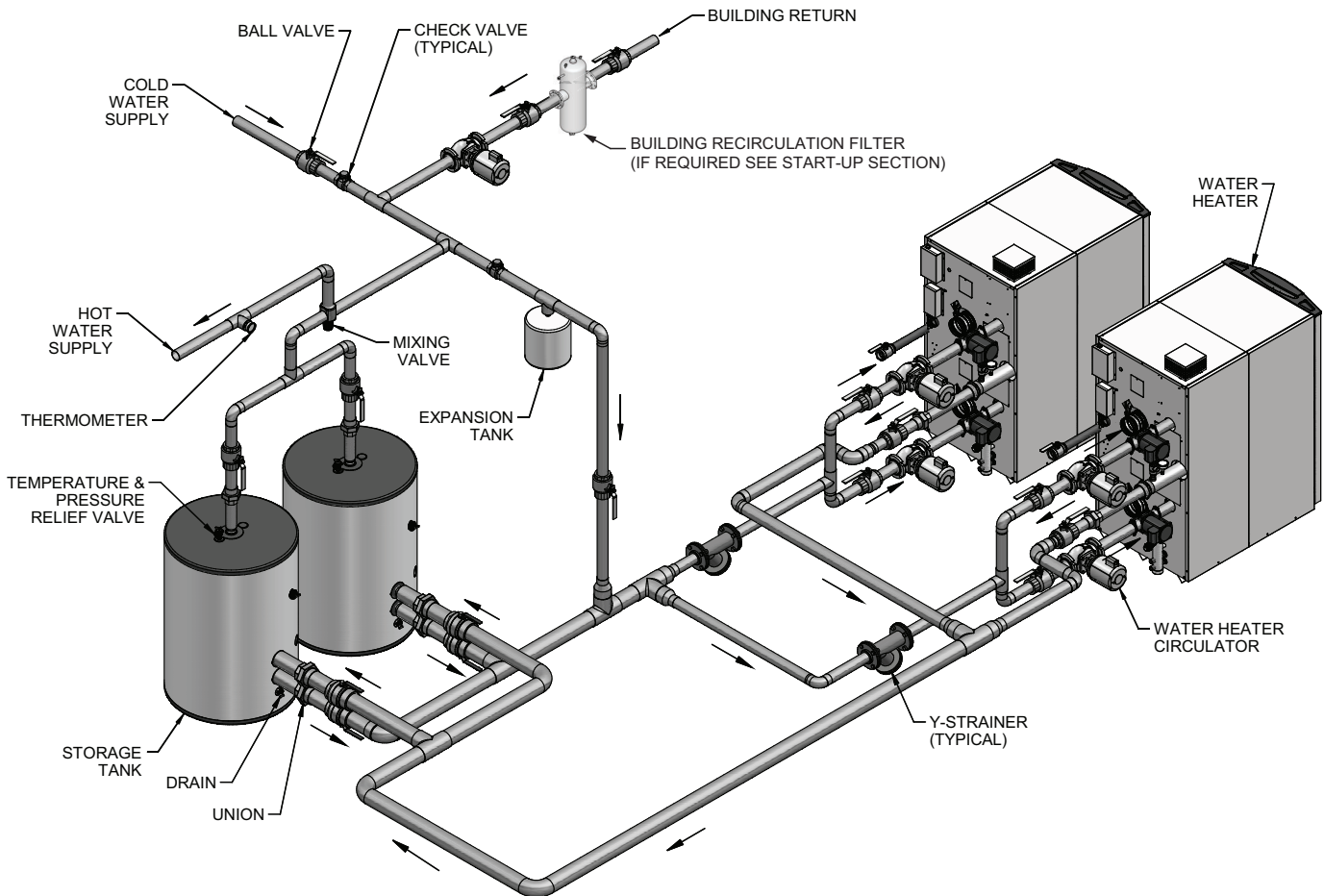

CAUTION The piping will not support the weight of the water heater circulator pump. Do not attempt to support the weight of the water heater circulator pump with the piping or its accessories. Refer to the pump manufacturer's installation instructions. Failure to comply could result in severe personal injury, death, or substantial property damage.

NOTICE Please note that these illustrations are meant to show system piping concept only, the installer is responsible for all equipment. The installer must follow all manufacturer's instructions for each system component. The installer is responsible for compliance with local codes.

7 Gas connections

Connecting gas supply piping

1. Refer to FIG. 7-1 to pipe gas to the water heater.
 - a. Install ground joint union for servicing, when required.
 - b. In Canada – When using manual main shutoff valves, it must be identified by the installer.
2. Install sediment trap / drip leg.

Figure 7-1 Gas Supply Piping

WARNING Ensure that the high gas pressure regulator is at least 10 feet (3 m) upstream of the appliance.

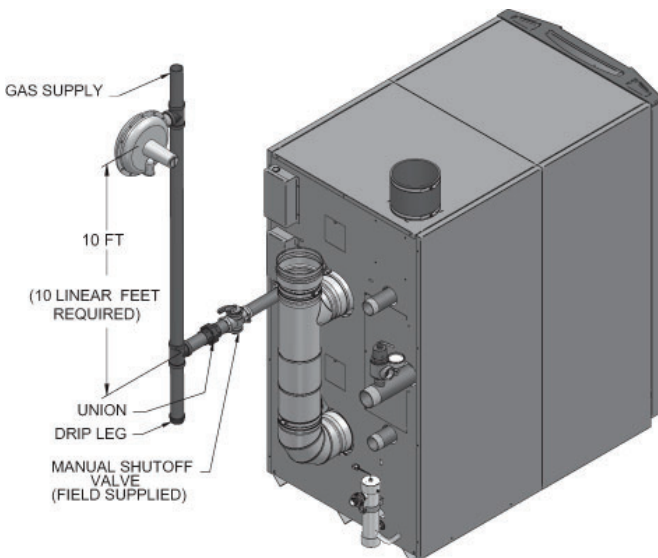

3. Support piping with hangers, not by the water heater or its accessories.

WARNING The gas valve and blower will not support the weight of the piping. Do not attempt to support the weight of the piping with the water heater or its accessories. Failure to comply could result in severe personal injury, death, or substantial property damage.

4. Purge all air from the gas supply piping.
5. Before placing the water heater in operation, check the water heater and its gas connection for leaks.
 - a. The appliance must be disconnected from the gas supply piping system during any pressure testing of that system at a test pressure in excess of 1/2 PSIG (3.5 kPa).
 - b. The appliance must be isolated from the gas supply piping system by closing a manual shutoff valve during any pressure testing of the gas supply piping system at test pressures equal to or less than 1/2 PSIG (3.5 kPa).
 - c. The appliance and its gas connection must be leak tested before placing it in operation.

WARNING Do not check for gas leaks with an open flame – use the bubble test. Failure to use the bubble test or check for gas leaks can cause severe personal injury, death, or substantial property damage.

6. Use pipe sealing compound compatible with propane gases. Apply sparingly only to male threads of the pipe joints so that pipe dope does not block gas flow.
7. Be sure gas lines are clean and free of oils and debris.

WARNING Failure to apply pipe sealing compound as detailed in this manual can result in severe personal injury, death, or substantial property damage.

7 Gas connections

WARNING Use two wrenches when tightening gas piping at water heater (FIG. 7-2), using one wrench to prevent the water heater gas line connection from turning. Failure to support the water heater gas connection pipe to prevent it from turning could damage gas line components.

Figure 7-2 Inlet Pipe with Backup Wrench

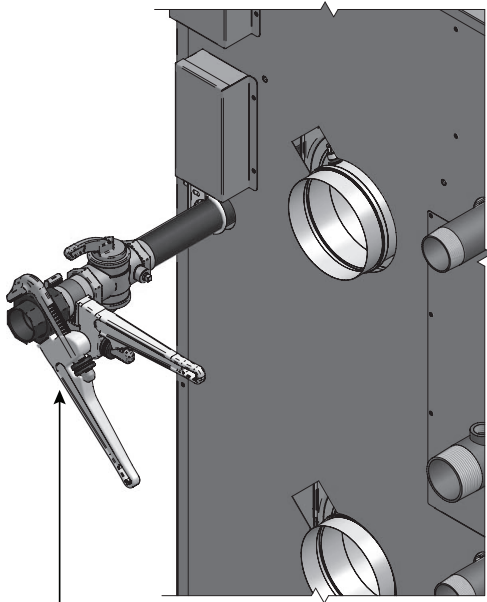

USE BACK UP WRENCH TO PREVENT PIPE FROM ROTATING

NOTICE Maximum inlet gas pressure must not exceed the value specified. Minimum value listed is for the purposes of input adjustment.

Natural gas:

WARNING Check water heater rating plate to determine which fuel the water heater is set for. Armor X2 water heaters CANNOT be field converted. Failure to comply could result in severe personal injury, death, or substantial property damage.

Pipe sizing for natural gas

1. Refer to Table 7A for pipe length and diameter. Based on rated water heater input (divide by 1,000 to obtain cubic feet per hour).
 - a. Table 7A is only for natural gas with specific gravity 0.60 inches, with a pressure drop through the gas piping of 0.3 inches w.c.
 - b. For additional gas pipe sizing information, refer to ANSI Z223.1 (or B149.1 for Canadian installations).

Natural gas supply pressure requirements

1. Pressure required at the gas valve inlet pressure port:
 - Maximum 14 inches w.c. (3.5 kPa) with no flow (lockup) or with water heater on.
 - Minimum 5 inches w.c. (1.25 kPa) for 1.0 models with gas flowing (verify during water heater startup).
 - Minimum 4 inches w.c. (.99 kPa) for 1.3 - 1.5 models with gas flowing (verify during water heater startup).
2. Install 100% lockup gas pressure regulator in supply line if inlet pressure can exceed 14 inches w.c. (3.5 kPa) at any time. Adjust lockup regulator for 14 inches w.c. (3.5 kPa) maximum.

Propane Gas:

WARNING Check water heater rating plate to determine which fuel the water heater is set for. Armor X2 water heaters CAN NOT be field converted. Failure to comply could result in severe personal injury, death, or substantial property damage.

Pipe sizing for propane gas

1. Contact gas supplier to size pipes, tanks, and 100% lockup gas pressure regulator.

Propane Supply Pressure Requirements

1. Adjust propane supply regulator provided by the gas supplier for 14 inches w.c. (3.5 kPa) maximum pressure.
2. Pressure required at gas valve inlet pressure port:
 - Maximum 14 inches w.c. (3.5 kPa) with no flow (lockup) or with water heater on.
 - Minimum 8 inches w.c. (1.9 kPa) with gas flowing (verify during water heater startup).

WARNING Ensure that the high gas pressure regulator is at least 10 feet (3 m) upstream of the appliance.

7 Gas connections *(continued)*

Table 7A Natural Gas Pipe Size Chart

Capacity of Schedule 40 Metallic Pipe in Cubic Feet of Natural Gas Per Hour (based on .60 specific gravity, 0.30" w.c. pressure drop)														
Pipe Size (Inches)	Length of Pipe in Straight Feet													
	10	20	30	40	50	60	70	80	90	100	125	150	175	200
1/2	131	90	72	62	55	N/A	N/A	N/A	N/A	N/A	N/A	N/A	N/A	N/A
3/4	273	188	151	129	114	104	95	89	83	79	70	63	58	N/A
1	514	353	284	243	215	195	179	167	157	148	131	119	109	102
1 1/4	1,060	726	583	499	442	400	368	343	322	304	269	244	224	209
1 1/2	1,580	1,090	873	747	662	600	552	514	482	455	403	366	336	313
2	3,050	2,090	1,680	1,440	1,280	1,160	1,060	989	928	877	777	704	648	602
2 1/2	4,860	3,340	2,680	2,290	2,030	1,840	1,690	1,580	1,480	1,400	1,240	1,120	1,030	960
3	8,580	5,900	4,740	4,050	3,590	3,260	3,000	2,790	2,610	2,470	2,190	1,980	1,820	1,700
4	17,500	12,000	9,660	8,270	7,330	6,640	6,110	5,680	5,330	5,040	4,460	4,050	3,720	3,460

Check inlet gas supply

NOTICE

CSA or UL listed flexible gas connections are acceptable, but you must exercise caution to ensure that the line has adequate capacity to allow your water heater to fire at full rate. Consult with local codes for proper installation or service procedures.

⚠ WARNING

DO NOT adjust gas valve outlet pressure. Attempting to alter the gas valve outlet pressure could result in damage to the valve, causing potential severe personal injury, death, or substantial property damage.

The gas piping must be sized for the proper flow and length of pipe, to avoid excessive pressure drop. Both the gas meter and the gas regulator must be properly sized for the total gas load.

If you experience a pressure drop greater than 1 inch w.c. (249 Pa), the meter, regulator, or gas line is undersized or in need of service. Perform the steps below when checking inlet gas supply:

- Turn the main power switch to the "OFF" position.
- Shut off gas supply at the manual gas valve in the gas piping to the appliance.
- Remove the 1/8" pipe plug on the flange to the field supplied gas shutoff valve and install a suitable 1/8" fitting (field supplied) for the manometer tubing. Place the tubing of the manometer over the tap once the 1/8" fitting is installed as shown in FIG. 7-3.
- Slowly turn on the gas supply at the field installed manual gas valve.
- Turn the power switch to the "ON" position.
- Adjust the temperature set point on the control panel of the SMART TOUCH control module to call for heat.
- Observe the gas supply pressure as the burner fires at 100% of rated input. Percent of burner input will be displayed on the Burner Screen.
- Ensure inlet pressure is within specified range. Minimum and maximum gas supply pressures are specified in this section of the manual.
- If gas supply pressure is within normal range and no adjustments are needed, proceed on to Step 11.
- If the gas pressure is out of range, contact the gas utility, gas supplier, qualified installer or service agency to determine the necessary steps to provide proper gas pressure to the control.
- Turn the power switch to the "OFF" position.
- Shut off the gas supply at the manual gas valve in the gas piping to the appliance.
- Remove the manometer from the pressure tap on top of the gas valve. Remove the 1/8" (3 mm) field supplied fitting and reinstall the pipe plug removed in Step 3.

7 Gas connections

⚠ WARNING Do not check for gas leaks with an open flame -- use the bubble test. Failure to use the bubble test or check for gas leaks can cause severe personal injury, death, or substantial property damage.

14. Turn on the gas supply at the manual gas valve.
15. Turn the power switch to the "ON" position.
16. Adjust the temperature set point on the control panel of the SMART TOUCH control module to the desired water temperature so the appliance will call for heat.
17. Check burner performance by cycling the system while you observe burner response. The burner should ignite promptly. Flame pattern should be stable. Turn system off and allow burner to cool, then cycle burner again to ensure proper ignition and flame characteristics.

Figure 7-3 Inlet Gas Supply Check

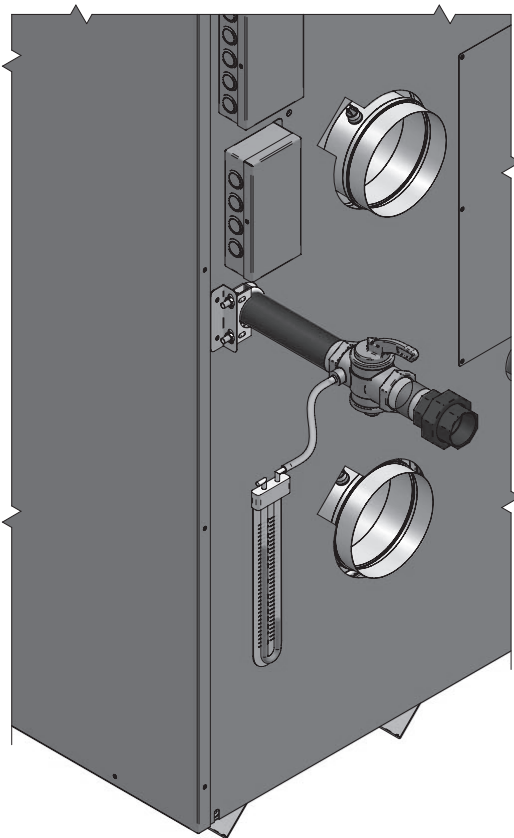

Gas Pressure

The gas pressure must remain between 4 inches w.c. (.99 kPa) minimum (5 inches w.c. for 1.0 models) and 14 inches w.c. (3.5 kPa) maximum for Natural gas and between 8 inches w.c. (1.9 kPa) minimum and 14 inches w.c. (3.5 kPa) maximum for LP gas during standby (static) mode and while in operating (dynamic) mode. If an in-line regulator is used, it must be a minimum of 10 feet (3 m) from the Armor X2 water heater. It is very important that the gas line is properly purged by the gas supplier or utility company. Failure to properly purge the lines or improper line sizing, will result in ignition failure.

The problem is especially noticeable in NEW LP installations and also in empty tank situations. This can also occur when a utility company shuts off service to an area to provide maintenance to their lines.

Gas valve replacement

The gas valve **MUST NOT** be replaced with a conventional gas valve under any circumstances. As an additional safety feature, this gas valve has a flanged connection to the venturi and blower.

⚠ WARNING Failure to follow all precautions could result in fire, explosion, or death!

⚠ WARNING DO NOT adjust gas valve outlet pressure. Attempting to alter the gas valve outlet pressure could result in damage to the valve, causing potential severe personal injury, death, or substantial property damage.

8 Field wiring

WARNING ELECTRICAL SHOCK HAZARD – For your safety, turn off electrical power supply before making any electrical connections to avoid possible electric shock hazard. Failure to do so can cause severe personal injury or death.

NOTICE Wiring must be N.E.C. Class 1.

If original wiring as supplied with water heater must be replaced, use only type 105°C wire or equivalent.

Water heater must be electrically grounded as required by National Electrical Code ANSI/NFPA 70 – latest edition.

CAUTION Label all wires prior to disconnection when servicing controls. Wiring errors can cause improper and dangerous operation.

Installation must comply with:

1. National Electrical Code and any other national, state, provincial, or local codes, or regulations.
2. In Canada, CSA C22.1 Canadian Electrical Code Part 1, and any local codes.

Line voltage connections

1. Connect 120 VAC power wiring to the line voltage terminal strip in the junction box, as shown in FIG. 8-1.
2. Provide and install a fused disconnect or service switch (15 amp recommended) as required by the code (see FIG. 8-1).
3. For supplied heater pumps, wire as shown in FIG. 8-1. Dry contacts are sized for 1.5 hp/120V, 3 hp/240V or 18 amps.
4. To activate a louver, connect to the dry contacts provided. Contacts are rated for 5 amps, 120V.

Figure 8-1 Line Voltage Field Wiring Connections

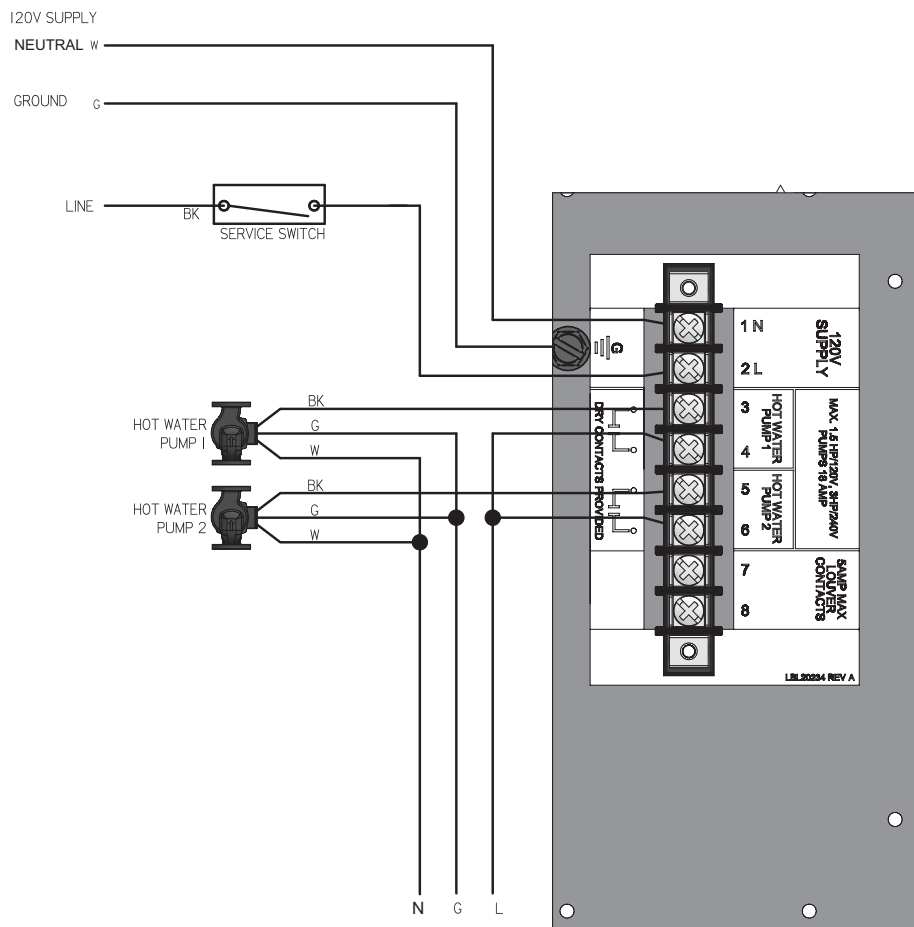

IMG00131

8 Field wiring

Low voltage connections

1. Route all low voltage wires through the knockouts in the rear of the water heater, as shown in FIG. 8-2.
2. Connect low voltage wiring to low voltage connection board as shown in FIG. 8-3 on page 46 of this manual and the water heater wiring diagram.

Figure 8-2 Routing Field Wiring

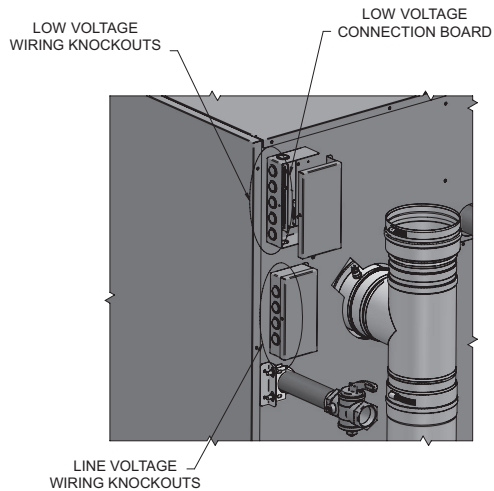

Runtime contacts

The SMART SYSTEM control closes a set of dry contacts whenever the burner is running. This is typically used by Building Management Systems to verify that the water heater is responding to a call for heat.

Alarm contacts

The SMART TOUCH control closes another set of contacts whenever the appliance is locked out or the power is turned off. This can be used to turn on an alarm, or signal a Building Management System that the water heater is down. Note that these contacts will close momentarily at the end of each call for heat or at least every 24 hours.

Wiring of the cascade

When wiring the water heaters for Cascade operation, select one water heater as the Leader water heater. The remaining water heaters will be designated as Members. See page 49 “Configuration of the Cascade” for a detailed explanation of this procedure.

Connect the tank sensor to the Leader water heater. For the Cascade system to work properly the tank sensor must be installed. The tank sensor should be wired to the low voltage connection board at the terminals marked for the tank sensor (see FIG. 8-3). The Leader control will use the water temperature at the tank sensor to control the operation of the Cascade. A tank sensor is not required when a BMS is controlling the Cascade firing rate through 0 - 10V BMS input or through ModBus.

If a remote enable is used, remove the jumper wire from the enable contacts and connect the remote enable dry contacts in its place. If the SMART TOUCH control is being controlled by a Building Management System (BMS), a call for heat may be initiated by the voltage applied to the 0 - 10 VDC input. The enable may be provided through ModBus as well.

Communication between the Leader water heater and the Member water heaters is accomplished by using shielded, 2-wire twisted pair communication cable. Connect one of the twisted pair wires to Cascade terminal A on each of the Low Voltage Connection boards, and the other wire of the twisted pair to Cascade terminal B on each of the Low Voltage Connection Boards. Connect the shield wires to one of the shield terminals on the Low Voltage Connection Boards (FIG. 8-3). If more than two water heaters are on the Cascade, daisy chain the wiring from the Cascade terminals on the second water heater to the Cascade terminals on the third water heater, then from the third to the fourth, and so on. The connections between heaters can be made in any order, regardless of the addresses of the water heaters. Try to keep each cable as short as possible.

8 Field wiring *(continued)*

Tank sensor

1. A tank sensor is required unless the heater is being given a firing rate through the 0 - 10V BMS input or through ModBus. By installing the tank sensor, the SMART SYSTEM control will perform the tank thermostat function. The SMART SYSTEM control generates a DHW call for heat when the tank temperature drops 6°F (3°C) below the tank set point and finishes the call for heat when the tank temperature reaches 3°F (1.5°C) above the tank set point.
2. The tank sensor [100208552](#) is the only sensor suitable for use with the SMART SYSTEM control. Connect the sensor leads to the Tank Sensor terminals on the Low Voltage Connection Board (FIG. 8-3). Consult the tank manufacturer for application and performance when used with any other indirect tank.

HEX1/HEX2 aux limit

An optional external control(s) may be connected across these terminals. Remove the jumper wire(s) and connect the control output(s) to these input(s). These external controls will generate a flow switch / LWCO lockout.

Louver proving switch

When the operation of the louvers needs to be verified before the water heater fires, remove the jumper wire from these terminals and connect them to the normally open contacts on its proving switch (FIG. 8-3).

ModBus

When the optional ModBus interface module is installed, the RS-485 ModBus cable is connected to these terminals. Use shielded, 2-wire twisted pair cable. If desired, the shield can be connected to ground by installing a jumper wire between terminals 1 and 3 on connector X5 on the optional ModBus interface module.

Gateways for Communication to BACNET or LON are available as an accessory. Consult the factory for availability.

Water heater Building Management System (BMS)

1. An external control may be connected to control either the firing rate or the set point of the water heater. If the external control uses a set of contacts to enable the water heater, connect the contacts to the Enable terminals. Otherwise, the SMART SYSTEM control can be enabled by the 0-10V signal.
2. Make sure the (-) terminal is connected to the ground/common output terminal of the external control, and the 0 - 10 VDC terminal is connected to the (+) terminal of the external control.

8 Field wiring

Figure 8-3 Low Voltage Field Wiring Connections

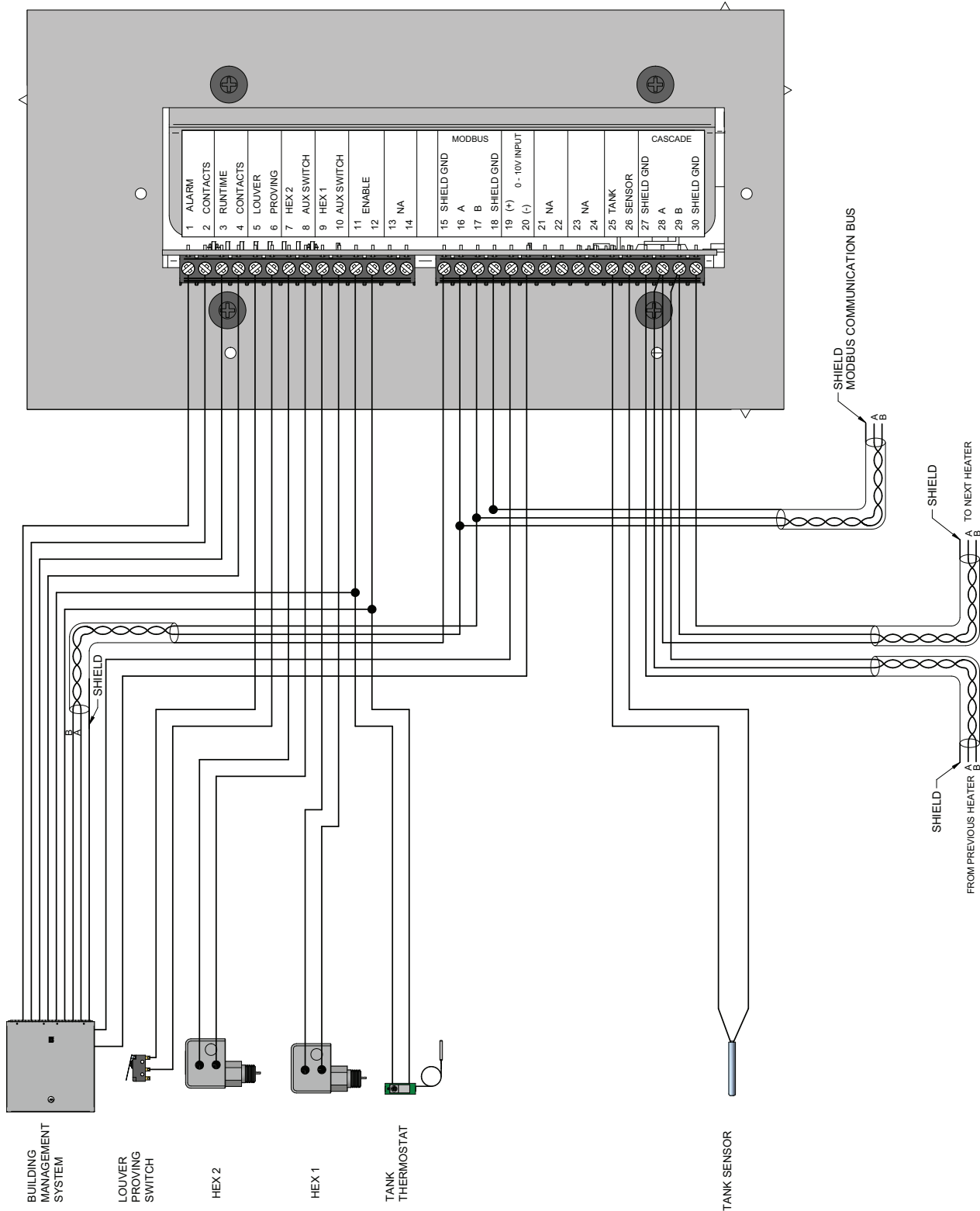

IMG00132

9 Condensate disposal

Condensate drain

1. This water heater is a high efficiency appliance that produces condensate.
2. The rear of the water heater has a 1/2 inch (12.7 mm) PVC union for connection of a 1/2 inch (12.7 mm) PVC pipe (FIG. 9-1).
3. Slope condensate tubing down and away from the water heater into a drain or condensate neutralizing filter. Condensate from the Armor X2 will be slightly acidic (typically with a pH from 3 to 5). Install a neutralizing filter if required by local codes.

A Neutralizer Kit (FIG. 9-1) is available from the factory.

4. Install the 1/2 inch (12.7 mm) PVC elbow (field provided) as shown in FIG. 9-1.
5. Do not expose condensate line to freezing temperatures.

NOTICE

Use materials approved by the authority having jurisdiction. In the absence of other authority, PVC and CPVC pipe must comply with ASTM D1785 or D2845. Cement and primer must comply with ASME D2564 or F493. For Canada use CSA or ULC certified PVC or CPVC pipe, fittings, and cement.

NOTICE

To allow for proper drainage on large horizontal runs, a second line vent may be required and tubing size may need to increase to 1 inch (25 mm).

The condensate line must remain unobstructed, allowing free flow of condensate. If condensate is allowed to freeze in the line or if the line is obstructed in any other manner, condensate can exit from the water heater, resulting in potential water damage to property.

6. A condensate removal pump is required if water heater is below drain. When installing a condensate pump, select one approved for use with condensing water heaters and furnaces. The pump should have an overflow switch to prevent property damage from condensate spillage. The switch should be wired to the auxiliary device proving switch terminals on the low voltage connection board.

Figure 9-1 Condensate Disposal

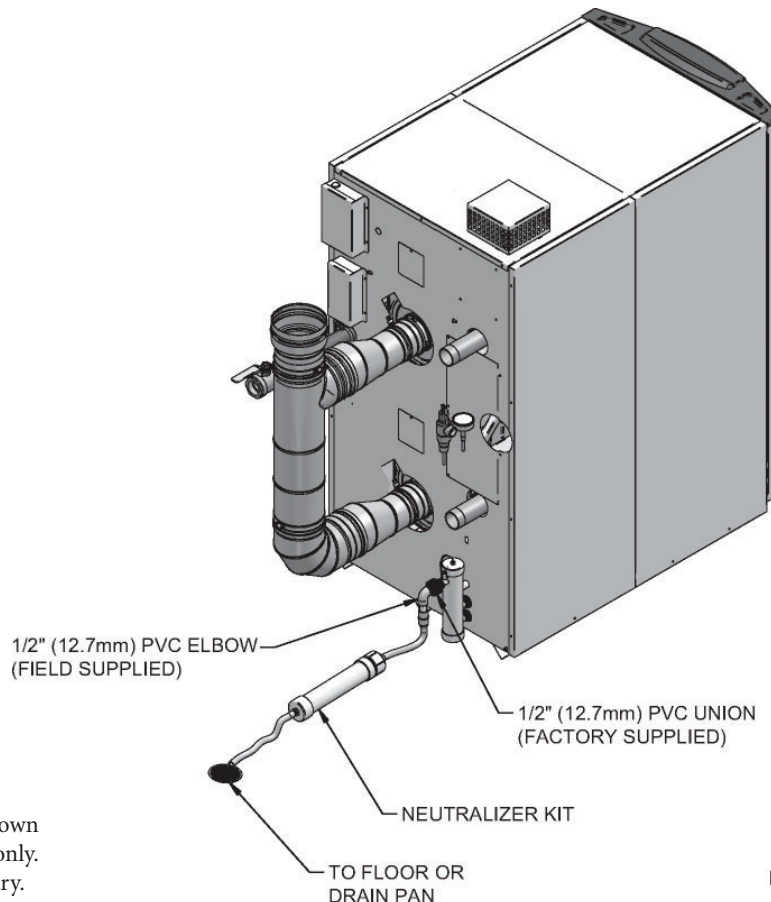

NOTE: Neutralizer shown for illustrative purposes only. Actual neutralizer may vary.

10 Start-up

Check/control water chemistry

NOTICE

Conduct water quality testing prior to installing the appliance. Various solutions are available to adjust water quality.

See the following table for properly operating the water heater with the appropriate water chemistry. Good water quality will help extend the life of the appliance by reducing the effects of scale buildup and corrosion.

Table 10A Water Chemistry

WATER CHEMISTRY		
Specification	Range	Requirement
Hardness	< 5 gpg	Follow recommendations detailed below (See Notice 3)
	5 to 12 gpg	Use Table 6B for pump recommendation
	12 to 15 gpg	Use Table 6B for pump recommendation
	> 15 gpg	Water softening system required (See Notice 4)
Dissolved Solids	< 350 ppm	Hardness level must be met
pH Level	6.5 to 8.5	Acceptable range
Chloride	< 150 ppm	Acceptable range

NOTICE

- Do not use the water heater to directly heat swimming pool or spa water.
- At initial fill and during water heater start-up and testing, check system thoroughly for any leaks. Repair all leaks before proceeding further.
- When water hardness levels are less than 5 gpg or 85.5 mg/l, the following is recommended:
 - Flush and clean existing water heating system prior to installation.
 - Inspect and, if necessary, replace the anodes in any existing tanks.
 - Install a Y-strainer on the inlet of each water heater as detailed in Section 6.
 - Limit the run time of the hot water recirculation loop.
 - Filter the hot water recirculation loop to a level of 10 microns. **CAUTION:** Check recirculation pump size to verify it is sized for filter addition and upsize if necessary.
- When water softener is required, a Template Assisted Crystallization system is recommended.

Check for gas leaks

WARNING

Before starting the water heater, and during initial operation, smell near the floor and around the water heater for gas odorant or any unusual odor. Remove the top access panel and smell the interior of the water heater enclosure. Do not proceed with startup if there is any indication of a gas leak. Use an approved leak detection solution. Repair any leaks at once.

WARNING

DO NOT adjust gas valve outlet pressure. The gas valve is factory set for the correct outlet pressure. This setting is suitable for natural gas and propane, requiring no field adjustment. Attempting to alter the gas valve outlet pressure could result in damage to the valve, causing potential severe personal injury, death, or substantial property damage.

WARNING

Propane water heaters only – Your propane supplier mixes an odorant with the propane to make its presence detectable. In some instances, the odorant can fade, and the gas may no longer have an odor. Before startup (and periodically thereafter), have the propane supplier verify the correct odorant level in the gas.

Inspect/fill condensate system

Inspect/check condensate lines and fittings

- Inspect the condensate drain line, condensate PVC fittings and condensate trap.

Fill condensate trap with water

- Remove the PVC cap retaining screw from the PVC cap (FIG. 10-1).
- Remove the 2 inch PVC cap with the switch located at the top of the trap (FIG. 10-1).
- Fill with fresh water until the water begins to pour out of the drain.
- Replace the cap. Press the cap onto the trap until the cap makes contact with the drain.
- Replace the retaining screw.

WARNING

The condensate trap (FIG. 10-1) must be filled with water during all times of water heater operation to avoid flue gas emission from the condensate drain line. Failure to fill the trap could result in severe personal injury or death.

Figure 10-1 Condensate Trap

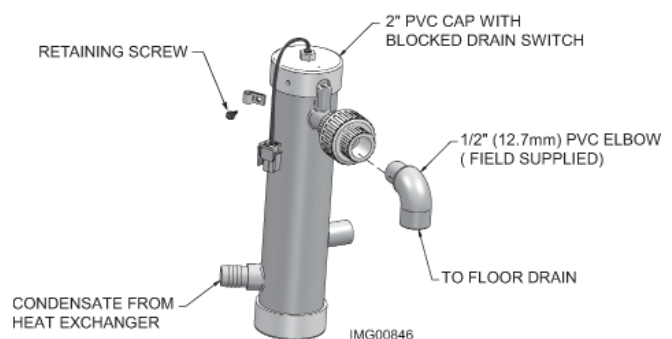

10 Start-up *(continued)*

Final checks before starting the water heater

- ❑ Read the Armor X2 Water Heater Service Manual to familiarize yourself with SMART SYSTEM control module operation. Read this manual, page 50 for proper steps to start the water heater.
- ❑ Verify the water heater and system are full of water and all system components are correctly set for operation.
- ❑ Verify the preparation procedures of Section 10, pages 48 and 49 have been completed.
- ❑ Fill the vent condensate trap with water (removing the retaining screw in order to remove the 2 inch PVC cap with the switch located at the top of the trap). Replace the cap. Press the cap onto the trap until the cap makes contact with the drain. Replace the retaining screw.
- ❑ Verify electrical connections are correct and securely attached.
- ❑ Inspect vent piping and air piping for signs of deterioration from corrosion, physical damage or sagging. Verify air piping and vent piping are intact and correctly installed per this manual.

Start the water heater

1. Read and follow the Operating instructions in FIG. 10-2, page 50.

If water heater does not start correctly

1. Check for loose connections, blown fuse or service switch off?
2. Is water heater water temperature above 200°F?
3. Is tank thermostat or tank set point set below room temperature?
4. Is gas turned on at meter or water heater?
5. Is incoming gas pressure less than 4 inches w.c.?

If none of the above corrects the problem, refer to the Troubleshooting Section of the Armor X2 Water Heater Service Manual.

Check system and water heater

❑ Check water piping

1. Check system piping for leaks. If found, shut down the water heater and repair immediately. (See WARNINGS on pages 48 and 49 (startup) regarding failure to repair leaks.)
2. Check Delta T. Reference Section 6 - *System Piping* on page 33 for more information regarding Delta T.
3. Vent any remaining air from the system using manual vents. Air in the system will interfere with circulation and cause heat distribution problems and noise.

❑ Check vent piping and air piping

1. Check for gastight seal at every connection, seam of air piping, and vent piping.

WARNING

Venting system must be sealed gastight to prevent flue gas spillage and carbon monoxide emissions, which will result in severe personal injury or death.

❑ Check gas piping

1. Check around the water heater for gas odor following the procedure on page 39 of this manual (*Connecting Gas Supply Piping*).

WARNING

If you discover evidence of any gas leak, shut down the water heater at once. Find the leak source with a bubble test and repair immediately. Do not start the water heater again until corrected. Failure to comply could result in severe personal injury, death, or substantial property damage.

Check flame and combustion

1. Turn the main power off to the water heater by placing the "On/Off" switch in the OFF position.
2. Remove the flue temperature sensor from the flue pipe connection. **Note:** Combustion measurements will be made at this point.
3. Turn the main power on to the water heater by placing the "On/Off" switch in the ON position.

10 Start-up

Figure 10-2 Operating Instructions

FOR YOUR SAFETY READ BEFORE OPERATING

WARNING: If you do not follow these instructions exactly, a fire or explosion may result causing property damage, personal injury, or loss of life.

- A. This appliance does not have a pilot. It is equipped with an ignition device which automatically lights the burner. Do not try to light the burner by hand.
 - B. BEFORE OPERATING smell all around the appliance area for gas. Be sure to smell next to the floor because some gas is heavier than air and will settle on the floor.
- WHAT TO DO IF YOU SMELL GAS**
- Do not try to light any appliance.
 - Do not touch any electric switch; do not use any phone in your building.
 - Immediately call your gas supplier from a neighbor's phone. Follow the gas supplier's instructions.
 - If you cannot reach your gas supplier, call the fire department.
- C. Use only your hand to turn the gas control knob. Never use tools. If the handle will not turn by hand, don't try to repair it, call a qualified service technician. Force or attempted repair may result in a fire or explosion.
 - D. Do not use this appliance if any part has been under water. Immediately call a qualified service technician to inspect the appliance and to replace any part of the control system and any gas control which has been under water.

OPERATING INSTRUCTIONS

1. **STOP!** Read the safety information above on this label.
2. Set the thermostat to lowest setting.
3. Turn off all electric power to the appliance.
4. This appliance is equipped with an ignition device which automatically lights the burner. Do not try to light the burner by hand.
5. Remove front door.
6. Turn gas shutoff valves counterclockwise to "OFF". Handle will be perpendicular to pipe. Do not force.
7. Wait five (5) minutes to clear out any gas. If you then smell gas, **STOP!** Follow "B" in the safety information above this label. If you don't smell gas, go to next step.
8. Turn gas shutoff valve clockwise to "ON". Handle will be parallel to pipe.
9. Install top cover.
10. Turn on all electric power to appliance.
11. Set thermostat to desired setting.
12. If the appliance will not operate, follow the instructions "To Turn Off Gas To Appliance" and call your service technician or gas supplier.

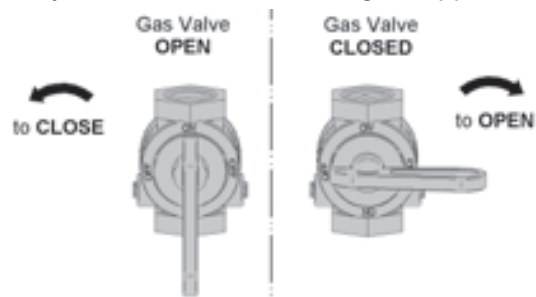

TO TURN OFF GAS TO APPLIANCE

1. Set the thermostat to lowest setting.
2. Turn off all electric power to the appliance if service is to be performed.
3. Remove front door.
4. Turn gas shut off valves counterclockwise to "OFF". Handle will be perpendicular to pipe. Do not force.
5. Install front door.

LBL20053 REVA

10 Start-up *(continued)*

Check flame and combustion *(continued)*

- Navigate to the Service Mode Screen from the Status Screen by pressing the MAIN button and then the SERVICE MODE button.
- On the Service Screen place Heat Exchanger 1 into operation by selecting Heat Exchanger 1 with the SELECT button and turning the heat exchanger on by pressing the ON/OFF button (OFF indicates that the heat exchanger is off and ON indicates that the heat exchanger should be firing).
- Insert the probe from a combustion analyzer into the hole left by the removal of the flue temperature sensor.

Note: Heat Exchanger 1 is the top heat exchanger; please ensure the probe is in the top flue sensor location.

- Once the heat exchanger has modulated up to full fire measure the combustion. The values should be in the range listed in Table 10A below. CO levels should be less than 200 ppm for a properly installed unit. If the combustion is not within range reference the *Troubleshooting* Section in the Armor X2 Service Manual for possible causes and corrective actions.

Table 10A Flue Products Chart

Natural Gas		Propane	
CO ₂	O ₂	CO ₂	O ₂
8.0% - 10%	3.0% - 6.5%	9.0% - 11%	4.1% - 6.9%

- Once the Heat Exchanger 1 analysis is complete, test the safety shutoff device by turning the manual shutoff valve to the OFF position and ensuring that Heat Exchanger 1 shuts down and registers an alarm. Open the manual shutoff valve, reset the control, and return to Service Mode.
- Repeat the same procedure for Heat Exchanger 2 by selecting Heat Exchanger 2 while on the Service Mode Screen. Be certain to insert the probe from the combustion analyzer into the Heat Exchanger 2 flue temperature sensor location.
- Turn the main power off to the water heater and replace the flue temperature sensor into the flue pipe connection.
- Place the water heater back into normal operation.



WARNING You must replace the flue gas temperature sensor to prevent flue gas spillage into the room. Failure to comply could result in severe personal injury, death, or substantial property damage.

Set heating operation

Set hot water set point temperature

During normal operation, hot water set point temperatures can be adjusted from the Set Points Menu. Press the following buttons to navigate to the Set Points Menu from the Status Screen:



- To change a set point, press the SELECT button next to the user set point parameter.
- The first time the user set point parameter is accessed, you will be required to enter the user password. The user password is 0704.
- Using the keypad, enter the password and then press the OK button. If the password is not entered correctly, the screen will revert to the Parameter List Screen and you will not be able to adjust the set point. If a digit has been entered incorrectly, press the left arrow key on the keypad to back the digit up. If the password has been entered correctly, the Parameter Change Screen will appear. The Parameter Change Screen will display the set point being changed, the previous setting of the set point, and adjustment buttons.
- To adjust the set point, press the + or - buttons to change the value being displayed.
- Once the set point has been adjusted to the desired setting press the APPLY button to change the set point and return to the Parameter List Screen.
- If no other changes are necessary, press the BACK button to return to the Parameter List Screen.
- Once all the necessary adjustments have been made, press the BACK button to return to the Setup Screen.
- Press the SAVE button to program all changes made to the set points and return to the Status Screen. Leaving the Setup Screen without pressing the SAVE button will erase the changes made to the set points and change them back to their previous settings.

Note: The SAVE button must be pressed to ensure proper programming of the controls. Failure to press the SAVE button will require all changes to be reprogrammed.

10 Start-up

Set clock

To program the clock, access the night setback parameter by pressing the following buttons:



The SMART TOUCH control has a built-in clock that it uses for its night setback feature and for logging events. This clock must be set when the water heater is installed, and anytime the water heater has been powered off for more than one month. Use the following procedure to set the clock:

1. To set the clock, press the SELECT button in the upper right-hand corner of the display. The date and time are displayed as “Day dd/mm/yy hh:mm”. Day = day of the week (1 = Monday, 2 = Tuesday, etc.), dd = date, mm = month, yy = year, hh = hour, mm = minutes (24 hour time; 2:30PM = 14:30).
2. Using the keypad, adjust the date and time by working from left to right. If a digit has been entered incorrectly, press the left arrow key on the keypad to back the digit up. If no change is necessary, press the BACK button to return to the Parameter List Screen. Once the correct date and time have been entered press the OK button on the display to program the date and time into memory and return to the Parameter List Screen.

NOTICE

The internal clock does not adjust for Daylight Savings Time and therefore, will require a manual adjustment.

Configuration of the cascade

When installed in a Cascade system, the individual controls must be programmed for cascade operation. To program the cascade parameters, access the Cascade Menu found in the Setup Menu by pressing the following buttons:



Note: The CASCADE button on the Main Menu will only display the current status of the cascade.

1. Once in the Cascade Setup Menu select the appropriate parameter by pressing the SELECT button.
2. The first time the cascade setup parameters are accessed, you will be required to enter the service password. Enter the service password as described in the Armor X2 Service Manual.
3. Once the password has been entered correctly, the Parameter Change Screen will appear. The Parameter Change Screen will display the parameter being changed, the previous setting of the parameter, and adjustment buttons.
4. To adjust the parameter, press the + or - buttons to change the value being displayed.
5. Make the correct adjustments and then press the APPLY button.
6. Once all the parameters have been adjusted press the BACK button. This will return you to the Setup Menu.
7. Press the SAVE button to program all controls.

Note: The SAVE button must be pressed to ensure proper programming of the controls. Failure to press the SAVE button will require all changes to be reprogrammed.

11 Operating information

General

How the appliance operates

The Armor X2 uses advanced stainless steel heat exchangers and electronic control modules that allow fully condensing operation. The blowers pull in air and push flue products out of the water heater through the heat exchangers and flue piping. The control modules regulate blower speed to control the firing rate. The gas valve senses the amount of air flowing into the water heater and allows only the right amount of gas to flow.

How the control modules operate

The Armor X2 water heater is equipped with two (2) SMART TOUCH control modules. The control modules work in synchronization to meet the heat demand of the system.

The SMART TOUCH control modules receive input from water heater sensors and external inputs. The control modules activate and control the blowers and gas valves to regulate heat input and switches the pumps on and off as needed. The user programs the control modules to meet hot water heating needs by adjusting control parameters. These parameters set operating temperatures and water heater operating modes. Water heater operation is based on tank temperature, the 0-10V BMS input, or ModBus.

Control inputs and outputs

0 - 10V input (set point or power)

The Armor X2 can be controlled by a Building Management System (BMS) using a 0 - 10 VDC signal. The control can be configured by the installer to use this signal to either control set point or firing rate.

Tank sensor

This input tells the water heater the temperature inside the HW tank.

Anti-cycling

After a HW demand has been satisfied, the control will delay the next HW call for a set time period (time is adjustable by the installer). The time delay will be bypassed if the inlet water temperature drops too far during the delay.

HW pump control

When a HW call for heat starts, the appropriate HW pump is turned on.

Louver

A dry contact is provided to open and close louvers whenever the Armor X2 water heater requires combustion air from inside the room. Connect the Louver End Switch to the Louver Proving Switch input on the Low Voltage Connection Board.

Temperature control

Modulation

The Armor X2 is capable of modulating its firing rate from a minimum of 10% to a maximum of 100%. The firing rate is dictated by the call for heat, the HW draw, and various other temperature limitations.

Night setback

The controller may be programmed to reduce the tank set point during a certain time each day. A start and stop time can be programmed for each day of the week.

Flame current support

To prevent nuisance shutdowns when the water heater is firing at minimum rates, the control will increase the firing rate when the flame signal drops below 5 μ A.

11 Operating information

Protection features

Outlet temperature, flue temperature, and temperature rise limiting

The outlet temperature is monitored by the water heater outlet temperature sensor. When the outlet temperature exceeds 185°F (85°C), the unit will reduce the fan speed. If the outlet water temperature exceeds 195°F (90°C) the control will shut the unit down until it cools off.

The control module monitors the flue temperature by a sensor located in the flue exhaust. If the flue temperature exceeds 215°F (102°C) the control will reduce the maximum fan speed. If the flue temperature exceeds 225°F (107°C) the control will shut the unit down. The unit will restart automatically once the flue temperature drops 10°F (6°C) and the minimum off time has expired.

The control monitors the temperature difference between the inlet and the outlet sensor. If the control determines the temperature rise is too high, it will either reduce the firing rate or shut down the unit as appropriate. The unit will restart automatically once the temperature difference has dropped below the allowable rise and the minimum off time has expired.

Freeze protection

DO NOT install the water heater in a room likely to freeze.

The following integral feature of the SMART TOUCH control module provides some protection for the water heater only -- not for the system.

- The SMART TOUCH control module provides freeze-up protection as follows when the water heater water temperature drops below 45°F (7°C):
- Below 45°F (7°C), the water heater pumps operate constantly.
- Below 37°F (3°C), the water heater turns on.
- Water heater and pumps turn off if water temperature rises above 45°F (7°C).

Monitor external limits

Connections are provided on the connection board for external limits. The SMART TOUCH control will shut off the burner and inhibit relighting whenever any of these external limits open.

Run-time and alarm outputs

The water heater provides dry contacts for indicating when the water heater is running, and when it is unable to operate.

Run-time and cycle counting

The control uses two timers to monitor the total hours of burner operation. One timer monitors the time the unit is firing under 50% of rate. The other timer monitors the time the unit is firing over 50% rate.

The control uses four (4) ignition counters to monitor the amount of unit cycles. The first counter counts all ignitions of the control. The second counter counts only ignition attempts that have failed. The third and fourth counters are the same as the first and second respectively, but can be reset by the installer.

Service reminder

The control can be programmed for service reminder notification. This notification will become active when either a set time frame has expired, or a set amount of running hours or cycles has expired (all adjustable by the installer). The display will alternate the standard text on the display screen with Service Due every 5 seconds. The service reminder notification can be reset by the installer.

Error logging

The control will hold in memory the last 10 error codes as well as the last 10 blockings. The date and time of the occurrence will be recorded as well. Only the 10 most current occurrences will be held in memory.

Water heater temperature regulation

Operating temperature (target)

The SMART TOUCH control module senses water temperature and regulates water heater firing and firing rate to achieve a target temperature. The target temperature can be set between 70°F (21°C) and 185°F (85°C).

11 Operating information *(continued)*

High limit operations

When outlet temperature exceeds 200°F (93.3°C), high limit action occurs. The appliance shuts down until the outlet water cools down.

Flow sensing device

The SMART TOUCH control module uses temperature sensing of both supply and return temperatures of the heat exchanger. If the flow rate is too low or the outlet temperatures too high, the control module modulates down and will shut the unit off. This ensures appliance shutdown in the event of low flow conditions.

Flow switch

Two flow switches are installed in the outlet manifold. These switches ensure there is sufficient water flow prior to firing the burner.

Cascade

When multiple units are installed, they can be wired together in a cascade sequence. A maximum of eight appliances can be controlled from a single control. In this application one water heater would be designated as the Leader control and all others would be designated as Member controls.

Once the Leader receives a call for heat from the Enable, 0 - 10 VDC input, or ModBus, the control will determine what the set point will be. A fixed temperature set point can be programmed into the control.

If the water temperature at the tank sensor is less than the set point - the off-on differential, then the control will initiate a call for heat on the Cascade (see the Armor X2 Service Manual for an explanation of the offset and differential). The Leader will energize the lead water heater on the Cascade. For a new startup this will be the Leader.

The water heater will fire at its ignition speed and will then modulate its firing rate to maintain the set point. If the first water heater reaches 100% of its firing rate, the Leader will calculate at what point the second appliance could fire at 10% of its firing rate. At this point, the Leader will fire the second appliance on the Cascade. For a new startup, this would be the first Member appliance. The water heater will fire at its ignition speed and will then modulate its firing rate to maintain the set point.

If the set point still cannot be met, the Leader will continue firing more Members until either the heat demand is met or all units on the Cascade are firing. As the heat demand decreases, the last appliance on will modulate down to 10% of its firing rate. Once the demand for that water heater is zero, it will shut down. As the heat demand decreases further, the second to last water heater will modulate down and shut off. This will continue until the demand is satisfied and all appliances are shut off.

A BMS can also control the firing rate of the Cascade directly through the 0 - 10V BMS input or through ModBus.

Sequence of the cascade

To equalize the run time of all appliances on the Cascade, the firing sequence will automatically be changed at set intervals.

For the first 24 hours after initializing the Cascade, the sequence will be changed every hour. After that the sequence will be changed once every 24 hours. The switching on/off sequence will be as follows:

TIME	SWITCHING ON SEQUENCE
Start	L-M1-M2-M3-M4-M5-M6-M7
+ 1 hour	M2-M3-M4-M5-M6-M7-L-M1
+ 2 hours	M4-M5-M6-M7-L-M1-M2-M3

Night Setback operation with cascade

Night Setback operation of the water heaters within the Cascade is available. Programming of the Night Setback will be done through the Leader. Refer to the Armor X2 Service Manual for information regarding Night Setback.

11 Operating information

Sequence of operation

Note: This unit is equipped with two (2) independent, but synchronized combustion systems. The Heat Exchanger 1 combustion system will fire first. If the demand cannot be met by one (1) combustion system the same sequence of operation will be followed to bring the Heat Exchanger 2 combustion system online.

1.	Upon a call for heat, the control turns on the appropriate pumps.
2.	The control confirms that the flow switch contacts are closed.
3.	The control starts the blower and closes the louver contacts to begin the Pre-Purge cycle.
4.	The control confirms that the blower comes up to the desired speed, the flap valve opens, and the air pressure switch, gas pressure switch (optional), louver proving switch (optional), and blocked drain switch contacts close.
5.	Once the Pre-Purge cycle is complete, the control lowers the blower speed, initiates sparking of the ignition electrode, and opens the gas valve.
6.	After a short wait, the control stops sparking and checks for the presence of flame current through the spark and flame sense electrodes.
7.	If the control does not detect flame current, the control will try again. If no flame current is detected on the second try, the control will lockout indefinitely until the RESET button on the touch screen LCD is pressed.
8.	If the control detects flame current, the control will hold the blower speed constant for a few seconds to allow the flame to stabilize, then begin modulating the firing rate in order to maintain the controlling sensor to the desired set point temperature.
9.	If the first heat exchanger in the water heater is unable to maintain the desired set point temperature, the second heat exchanger in the water heater will be started, using much of the same sequences as described above. Once both heat exchangers are firing, the controls will work in synchronization to maintain the desired set point temperature. If the heat load should decrease sufficiently, the second heat exchanger will be shut down, much like the sequences described below.
10.	Once the HW call for heat is satisfied, the control will turn off the gas valve and begin the Post-Purge cycle. The pumps that are running will begin their respective Pump Delay cycles.
11.	At the end of the Post-Purge cycle, the louver contacts will open.
12.	The control verifies that the blower stops running and the flap valve closes.
13.	At the end of the Pump Delay cycle(s), the pump(s) will be turned off.

11 Operating information *(continued)*

SMART TOUCH™ Armor X2 control module

The Status Screen displays water heater status, Cascade addresses, outlet water temperature, inlet water temperature, and tank temperature.

The water heater can be forced off by pressing the ON/OFF button. The Details Screen and Main Menu Screen can be accessed by pressing the appropriate button.

Figure 11-1 Status Screen

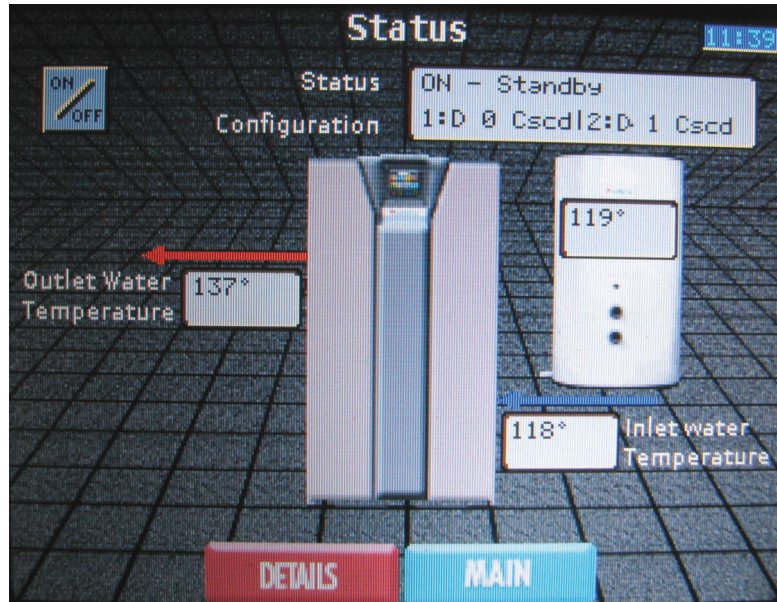

When the ON/OFF switch is turned to the ON position, the first screen visible on the LCD display will be the Status Screen. This screen displays the current status of the Armor X2 water heater. The following items can be viewed or interacted with on the Status Screen:

On/Off button - Pressing this button allows the water heater/Cascade to be placed in either Manual Shutdown Mode or Standby Mode.

Status - This line shows the current operating status of the Armor X2 water heater. Displayed items are as follows:

- Manual Shutdown - The water heater will not respond to either a system call or a hot water generation call.
- Standby - The water heater has not received a hot water generation call.
- HW Call for Heat - The water heater has received a hot water generation call.
- HW Pump Delay - The water heater has satisfied a hot water generation call and the hot water generator pumps are running for a fixed time to remove any residual heat.

- HW BMS - The water heater has received a call for heat from a 0-10 VDC BMS control.
- Service Set Point Met - While in Service Mode, the water temperature at either the outlet sensor or the system sensor has exceeded 185°F.
- HW Set Point Met - The tank water plus (+) offset temperature has exceeded the Tank Set Point.
- Anti-Cycle Delay - The water heater has satisfied a call for heat, but has received another call for heat before the anti-cycling time parameter has elapsed.
- Cascade ComError - A communication error has occurred between the Control Module 1 and Control Module 2 or between the Leader and Member water heaters.

11 Operating information

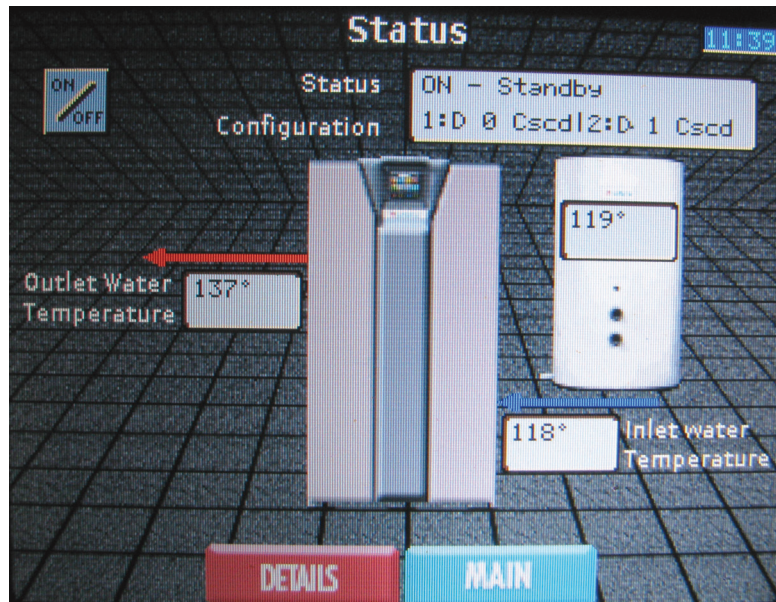

Configuration - This line shows the current configuration of the two control modules inside the unit.

Outlet Water Temperature - This is a calculated temperature based on the readings of the outlet temperatures of the active heat exchangers.

Inlet Water Temperature - This is a calculated temperature based on the inlet temperature readings from the active heat exchangers.

Hot Water Tank Temperature - This is the temperature as measured by the tank sensor in the hot water storage tank.

Time - The time is displayed in the upper right-hand corner of the display. It is displayed in 24 hour format. Reference the Armor X2 Service Manual for Night Setback parameters and more information regarding adjusting the date and time.

Details button - Pressing this button brings up the Details Screen. This screen shows the status of the various safeties, inputs, and outputs to each control module. Reference the Details Screen section in the Armor X2 Service Manual for more information regarding this screen.

Main button - Pressing this button brings up the Main Screen. From this screen navigation to eight (8) other screens is possible. Reference the Main Screen section on page 59 of this manual for more information regarding this screen.

11 Operating information *(continued)*

Use the Main Menu Screen (FIG. 11-2) to access the screens necessary to set temperatures, operating conditions, and monitor water heater operation.

The Armor X2 is equipped with a SMART TOUCH control system. All menu options are accessed by touching the screen with your finger or a stylus from a PDA.

Figure 11-2 Main Menu Screen

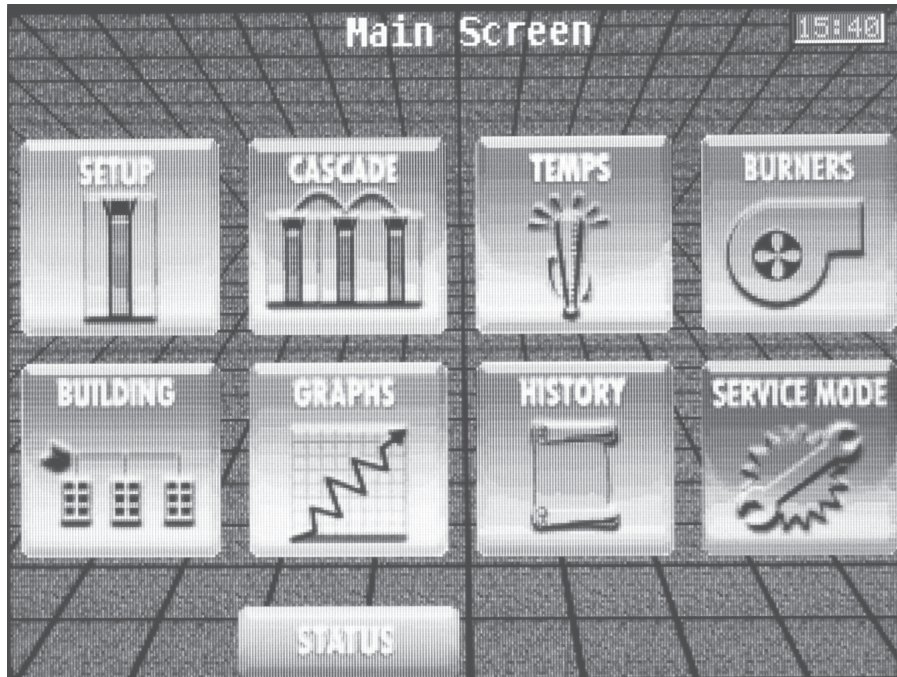

The Main Screen allows navigation to eight (8) additional screens which are used to set temperatures, operating conditions, and monitor water heater operation. These screens are as follows:

- Setup - Allows access to seven (7) other screens for the adjustment of the control parameters.
- Cascade - Shows the status of multiple units connected together in a cascade arrangement.
- Temps - Shows the temperatures measured by the individual sensors connected to the water heater.
- Burners - Shows the status of the two (2) independent burner systems used in the water heater.
- Building - Shows the information from a Building Integration System using Modbus Protocols.
- Graphs - Allows the selection of items to be graphed on a chart.
- History - Shows the operating and fault history of the two (2) control modules.
- Service Mode - Allows the installer to control the fan speed of the individual control modules for the purposes of combustion analysis. Service Mode will override all other heat demands, however, all safeties will remain active.

Navigation to the Main Screen can be accomplished by pressing the MAIN button at the bottom of the page.

Reference the Armor X2 Service Manual for more information regarding the eight (8) accessible screens.

Time - The time is displayed in the upper right-hand corner of the display. It is displayed in 24 hour format. Reference the night setback parameters in the Armor X2 Service Manual for information regarding adjusting the date and time.

Status button - Pressing this button displays the Status Screen. This screen shows the current status of the Armor X2 water heater. Reference pages 57 - 58 for more information regarding this screen.

12 Maintenance

Maintenance and annual startup

Table 12A Service and Maintenance Schedules

Service technician (see the following pages for instructions)		Owner maintenance	
ANNUAL START-UP	General:		
	<ul style="list-style-type: none"> • Address reported problems • Inspect interior; clean and vacuum if necessary; • Clean condensate trap and fill with fresh water • Check for leaks (water, gas, flue, condensate) • Verify flue and air lines in good condition and sealed tight • Check system water pressure/system piping/expansion tank • Check control settings • Check ignition and flame sense electrodes (sand off any deposits; clean and reposition) • Check wiring and connections • Perform start-up checkout and performance verification per Section 10 of this manual. • Flame inspection (stable, uniform) • Flame signal (at least 10 microamps at high fire) • Clean the heat exchanger if flue temperature is more than 54°F above supply water temperature. • Check Delta T (Temperature Rise) 	Daily	<ul style="list-style-type: none"> • Check water heater area • Check pressure/temperature gauge
	If combustion or performance indicate need:		Monthly
<ul style="list-style-type: none"> • Clean heat exchanger • Remove and clean burner using compressed air only • Clean the blower wheel 		Every 6 months	<ul style="list-style-type: none"> • Check water heater piping (gas and water) for leaks • Operate relief valve • Check water chemistry

12 Maintenance *(continued)*

⚠ WARNING Follow the service and maintenance procedures given throughout this manual and in component literature shipped with the water heater. Failure to perform the service and maintenance could result in damage to the water heater or system. Failure to follow the directions in this manual and component literature could result in severe personal injury, death, or substantial property damage.

⚠ WARNING The water heater should be inspected annually only by a qualified service technician. In addition, the maintenance and care of the water heater designated in Table 12A and explained on the following pages must be performed to assure maximum water heater efficiency and reliability. Failure to service and maintain the water heater and system could result in equipment failure.

⚠ WARNING Electrical shock hazard – Turn off power to the water heater before any service operation on the water heater except as noted otherwise in this instruction manual. Failure to turn off electrical power could result in electrical shock, causing severe personal injury or death.

Address reported problems

1. Inspect any problems reported by the owner and correct before proceeding.

Inspect water heater area

1. Verify that water heater area is free of any combustible materials, gasoline and other flammable vapors and liquids.
2. Verify that air intake area is free of any of the contaminants listed in Section 1 - Determine Water Heater Location. If any of these are present in the water heater intake air vicinity, they must be removed. If they cannot be removed, reinstall the air and vent lines per this manual and the Armor X2 Water Heater Service Manual.

Inspect water heater interior

1. Remove the front access cover and inspect the interior of the water heater.
2. Vacuum any sediment from inside the water heater and components. Remove any obstructions.

Clean condensate trap

1. Inspect the condensate drain line, condensate PVC fittings, and condensate trap.
2. Remove the PVC cap retaining screw from the PVC cap (FIG. 12-1).
3. Remove the 2 inch PVC cap with the switch located at the top of the trap (FIG. 12-1).
4. Remove any sediment in the trap.
5. Fill with fresh water until the water begins to pour out of the drain.
6. Replace the cap. Press the cap onto the trap until the cap makes contact with the drain.
7. Replace the retaining screw.

Figure 12-1 Condensate Trap

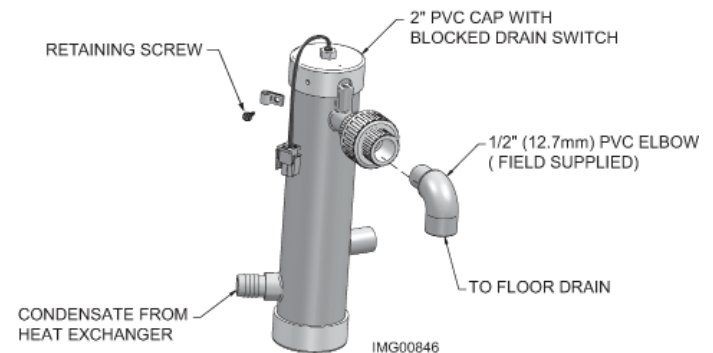

⚠ WARNING The condensate trap must be filled with water during all times of water heater operation to avoid flue gas emission from the condensate drain line. Failure to fill the trap could result in severe personal injury or death.

Check all piping for leaks

⚠ WARNING Eliminate all system or water heater leaks. Leaking water may cause severe property damage.

1. Inspect all water and gas piping and verify to be leak free.
2. Look for signs of leaking lines and correct any problems found.
3. Check gas line using the procedure found in Section 7 - Gas Connections.

Flue vent system and air piping

1. Visually inspect the entire flue gas venting system and air piping for blockage, deterioration or leakage. Repair any joints that show signs of leakage. Verify that air inlet pipe is connected and properly sealed.
2. Verify that water heater vent discharge and air intake are clean and free of obstructions.

12 Maintenance

⚠ WARNING Failure to inspect for the above conditions and have them repaired can result in severe personal injury or death.

Check water system

1. Verify all system components are correctly installed and operational.
2. Check the cold fill pressure for the system. Verify it is correct (must be a minimum of 12 PSI).
3. Watch the system pressure as the water heater heats up (during testing) to ensure pressure does not rise too high. Excessive pressure rise indicates expansion tank sizing or performance problem.
4. Inspect automatic air vents and air separators. Remove air vent caps and briefly push valve to flush vent. Replace caps. Make sure vents do not leak. Replace any leaking vents.

Check expansion tank

1. Expansion tanks provide space for water to move in and out as the heating system water expands due to temperature increase or contracts as the water cools. Tanks may be open, closed or diaphragm or bladder type. See Section 6 - System Piping for suggested best location of expansion tanks and air eliminators.

Check water heater relief valve

1. Inspect the relief valve and lift the lever to verify flow. Before operating any relief valve, ensure that it is piped with its discharge in a safe area to avoid severe scald potential. Read Section 6 - System Piping before proceeding further.

⚠ WARNING Safety relief valves should be re-inspected **AT LEAST ONCE EVERY THREE YEARS**, by a licensed plumbing contractor or authorized inspection agency, to ensure that the product has not been affected by corrosive water conditions and to ensure that the valve and discharge line have not been altered or tampered with illegally. Certain naturally occurring conditions may corrode the valve or its components over time, rendering the valve inoperative. Such conditions are not detectable unless the valve and its components are physically removed and inspected. This inspection must only be conducted by a plumbing contractor or authorized inspection agency – not by the owner. Failure to re-inspect the water heater relief valve as directed could result in unsafe pressure buildup, which can result in severe personal injury, death, or substantial property damage.

⚠ WARNING Following installation, the valve lever must be operated **AT LEAST ONCE A YEAR** to ensure that waterways are clear. Certain naturally occurring mineral deposits may adhere to the valve, rendering it inoperative. When manually operating the lever, water will discharge and precautions must be taken to avoid contact with hot water and to avoid water damage. Before operating lever, check to see that a discharge line is connected to this valve directing the flow of hot water from the valve to a proper place of disposal. Otherwise severe personal injury may result. If no water flows, valve is inoperative. Shut down the water heater until a new relief valve has been installed.

2. After following the above warning directions, if the relief valve weeps or will not seat properly, replace the relief valve. Ensure that the reason for relief valve weeping is the valve and not over-pressurization of the system due to expansion tank waterlogging or undersizing.

Inspect ignition and flame sense electrodes

1. Remove the ignition and flame sense electrodes from the water heater heat exchanger access cover.
2. Remove any deposits accumulated on the ignition/flame sense electrode using sandpaper. If the electrodes cannot be cleaned satisfactorily, replace with new ones.
3. Replace ignition/flame sense electrode, making sure gasket is in good condition and correctly positioned.

Check ignition ground wiring

1. Inspect water heater ground wire from the heat exchanger access cover to ground terminal strip.
2. Verify all wiring is in good condition and securely attached.
3. Check ground continuity of wiring using continuity meter.
4. Replace ground wires if ground continuity is not satisfactory.

Check all water heater wiring

1. Inspect all water heater wiring, making sure wires are in good condition and securely attached.

Check control settings

1. Set the SMART SYSTEM control module display to Parameter Mode and check all settings. See Section 1 of the Armor X2 Service Manual. Adjust settings if necessary. See Section 1 of the Armor X2 Service Manual for adjustment procedures.
2. Check settings of external limit controls (if any) and adjust if necessary.

12 Maintenance *(continued)*

Perform start-up and checks

1. Start water heater and perform checks and tests specified in Section 10 - *Start-up*.
2. Verify cold fill pressure is correct and that operating pressure does not go too high.

Check burner flame

1. Inspect flame through observation window.
2. If the flame is unsatisfactory at either high fire or low fire, turn off water heater and allow water heater to cool down. Remove the burners and clean them thoroughly using a vacuum cleaner or compressed air. Do not use compressed air to clean burners if performed inside a building.
3. Remove the burners, reference FIG. 12-2.
4. When replacing the burners, ensure gaskets are in good condition and positioned correctly (FIG. 12-2).

Figure 12-2 Burner Assembly

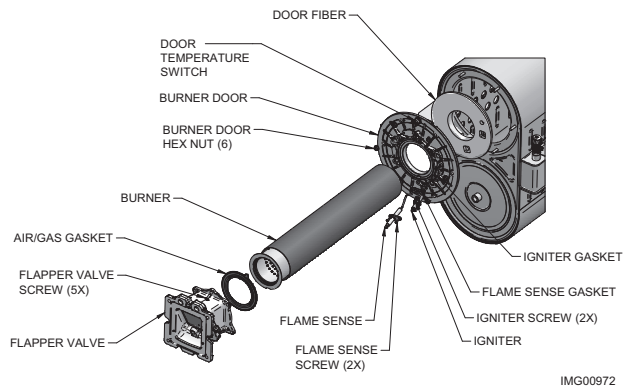

Check flame signal

1. At high fire the flame signal shown on the display should be at least 10 microamps.
2. A lower flame signal may indicate a fouled or damaged flame sense electrode. If cleaning the flame sense electrode does not improve, ground wiring is in good condition, and ground continuity is satisfactory, replace the flame sense electrode.
3. See Section 3 - *Troubleshooting* in the Armor X2 Service Manual for other procedures to deal with low flame signal.

Review with owner

1. Review this maintenance schedule with the owner.
2. Emphasize the need to perform the maintenance schedule specified in this manual.
3. Remind the owner of the need to call a licensed contractor should the water heater or system exhibit any unusual behavior.
4. Remind the owner to follow the proper shutdown procedure and to schedule an annual start-up at the beginning of the next heating season.

Cleaning the heat exchanger

For recommended materials; including brush, appropriate extension(s), refractory cover, and detailed instructions see Table 12B - Heat Exchanger Cleaning Kits.

1. Shut down water heater:
 - Follow the “To Turn Off Gas to Appliance” instructions for the water heater in Section 10 - Startup.
 - Do not drain the water heater unless it will be exposed to freezing temperatures. If using freeze prevention fluid in system, do not drain.
2. Allow time for the water heater to cool to room temperature if it has been firing.
3. Remove the nuts securing the heat exchanger access cover to the heat exchanger and set aside.
4. Remove the heat exchanger access cover, burner, and gas/air arm assembly.



WARNING

The water heater contains ceramic fiber materials. Use care when handling these materials per instructions on page 65 of this manual. Failure to comply could result in severe personal injury.

5. Remove the condensate hose from the heat exchanger end. Connect a field supplied 3/4” diameter hose to a drain pan. Using field supplied means, cover the refractory in the back of the combustion chamber of the heat exchanger.
6. Use a vacuum cleaner to remove any accumulation on the appliance heating surfaces. Do not use any solvent.
7. Brush the heat exchanger while dry using a nylon bristle brush. **Caution:** DO NOT use a metal brush. Re-vacuum the heat exchanger.
8. Finish cleaning using a clean cloth dampened with warm water. Rinse out debris with a low pressure water supply.
9. Allow the heat exchanger to thoroughly dry.
10. Remove the field supplied rear refractory cover from the back of the combustion chamber of the heat exchanger and reassemble.

12 Maintenance

11. Close isolation valves on piping to isolate water heater from system. Attach a hose to the water heater drain and flush water heater thoroughly with clean water by using purging valves to allow water to flow through the water make-up line to the water heater.
12. Perform start-up and check-out procedures in the Check Flame and Combustion - Section 10 - Startup on pages 49 and 51 of this manual.
13. Replace the access cover and restore water heater to operation.

Table 12B Heat Exchanger Cleaning Kits

Model Number	Kit Number	Part Number	Component Description
AW 1.0 - 1.5	100157628	100208309*	Nylon 4" Wheel Brush*
		100208310	1/4" x 12" Drill Extension
		100208311	1/4" x 24" Drill Extension

CAUTION

* Do NOT use a metal brush. Only use the kit provided brush or an equivalent replacement nylon brush.

Figure 12-3 Rope Gasket - Heat Exchanger Door

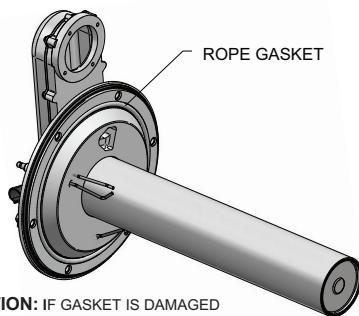

CAUTION: IF GASKET IS DAMAGED DO NOT REUSE, THE HEAT EXCHANGER DOOR MUST BE REPLACED.

NOTICE

Rope gasket is intended for sealing combustion (FIG. 12-3). If damaged DO NOT reuse, the heat exchanger door must be replaced. Consult factory for replacement heat exchanger door (kit [100173799](#)).

12 Maintenance *(continued)*

Handling ceramic fiber materials

REMOVAL OF COMBUSTION CHAMBER LINING

⚠ WARNING

The combustion chamber insulation in this appliance contains ceramic fiber material. Ceramic fibers can be converted to cristobalite in very high temperature applications. The International Agency for Research on Cancer (IARC) has concluded, "Crystalline silica in the form of quartz or cristobalite from occupational sources is carcinogenic to humans (Group 1)." Normal operating temperatures in this appliance are below the level to convert ceramic fibers to cristobalite. Abnormal operating conditions would have to be created to convert the ceramic fibers in this appliance to cristobalite.

The ceramic fiber material used in this appliance is an irritant; when handling or replacing the ceramic materials it is advisable that the installer follow these safety guidelines.

- Avoid breathing dust and contact with skin and eyes.
 - Use NIOSH certified dust respirator (N95). This type of respirator is based on the OSHA requirements for cristobalite at the time this document was written. Other types of respirators may be needed depending on the job site conditions. Current NIOSH recommendations can be found on the NIOSH website at <http://www.cdc.gov/niosh/homepage.html>. NIOSH approved respirators, manufacturers, and phone numbers are also listed on this website.
 - Wear long-sleeved, loose fitting clothing, gloves, and eye protection.
- Apply enough water to the combustion chamber lining to prevent airborne dust.
- Remove the combustion chamber lining from the water heater and place it in a plastic bag for disposal.
- Wash potentially contaminated clothes separately from other clothing. Rinse clothes washer thoroughly.

NIOSH stated First Aid.

- Eye: Irrigate immediately.
- Breathing: Fresh air.

13 Diagrams

Figure 13-1 Ladder Diagram_Part 1

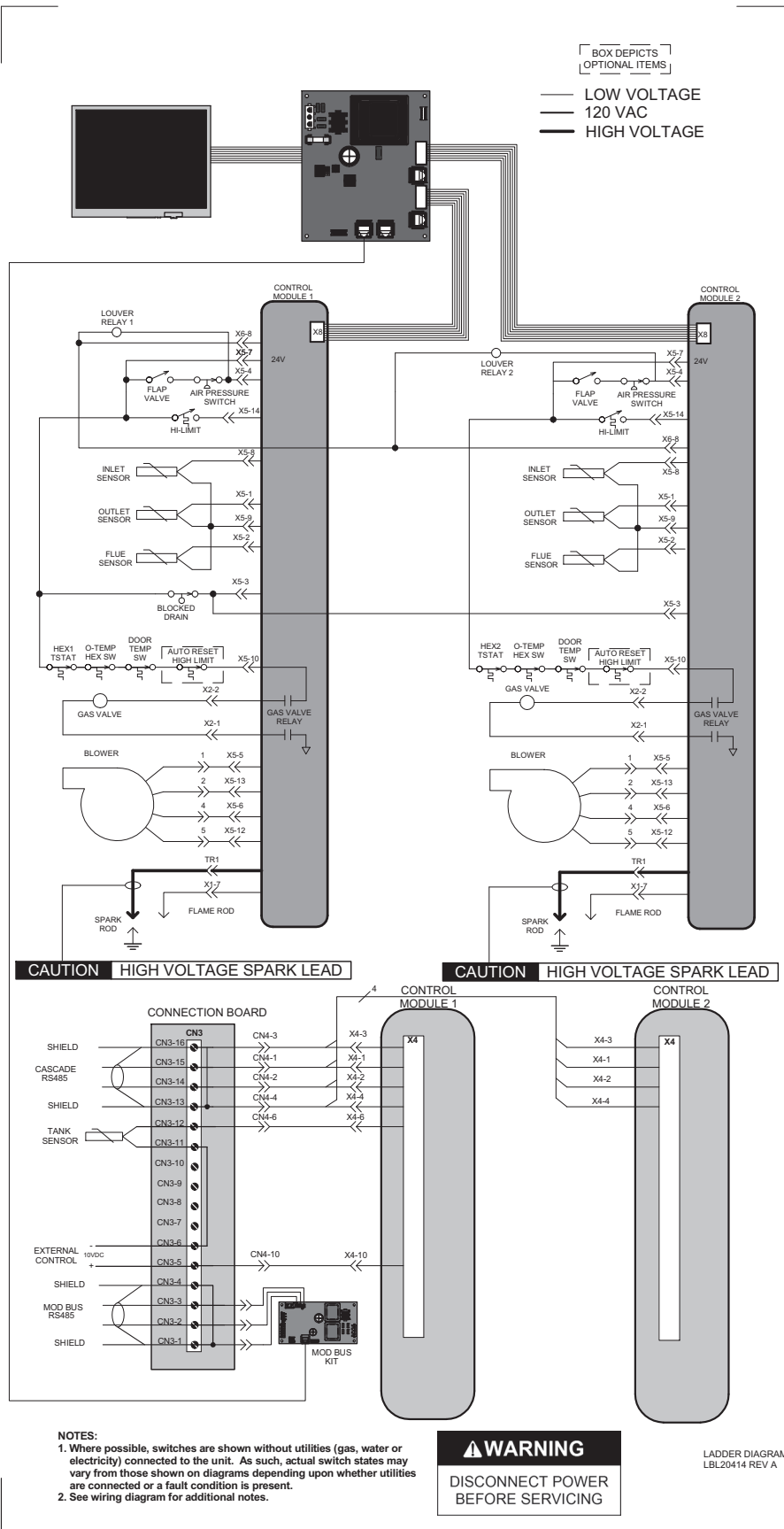

13 Diagrams *(continued)*

Figure 13-2 Ladder Diagram_Part 2

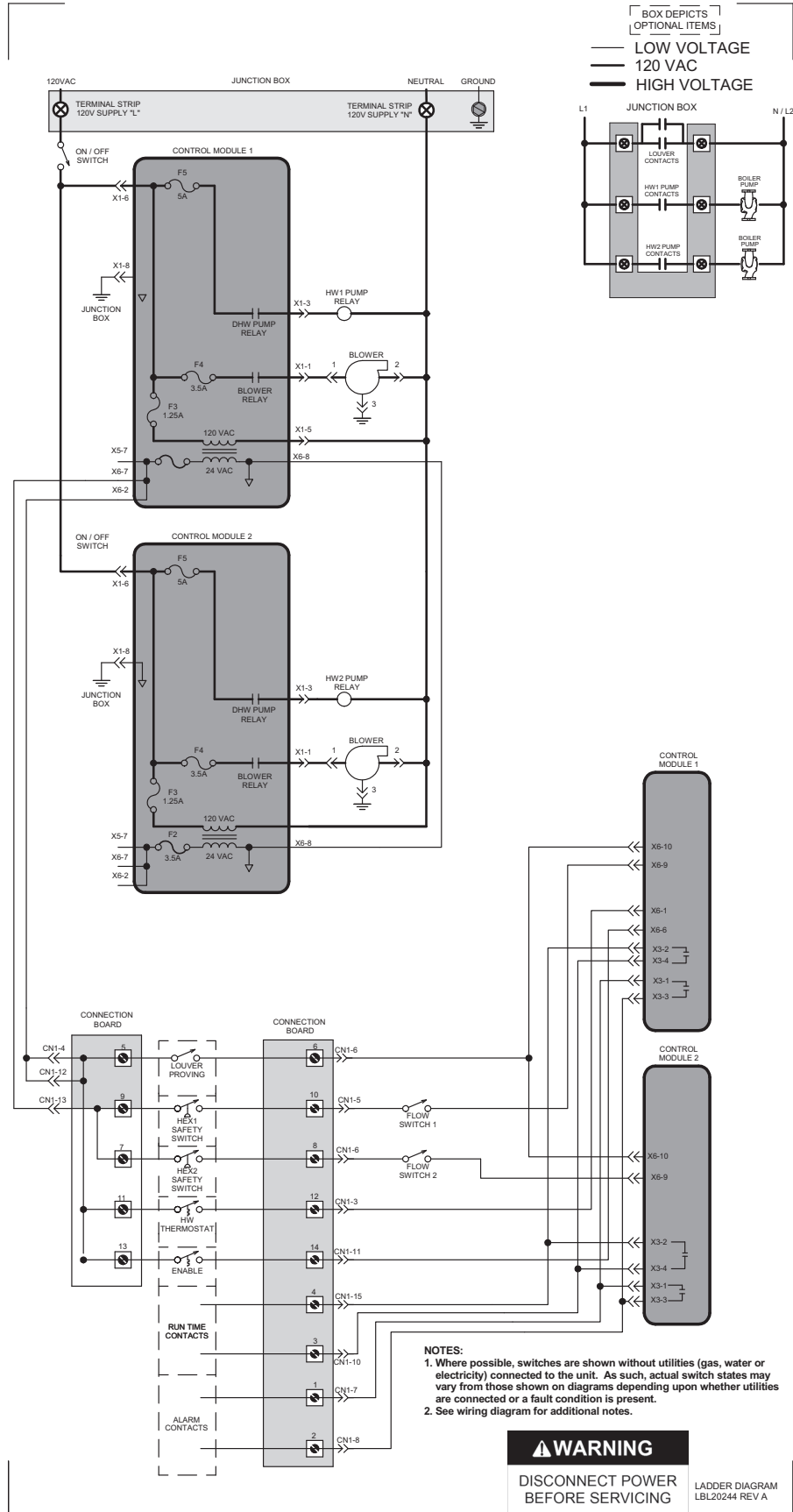

13 Diagrams

Figure 13-3 Wiring Diagram

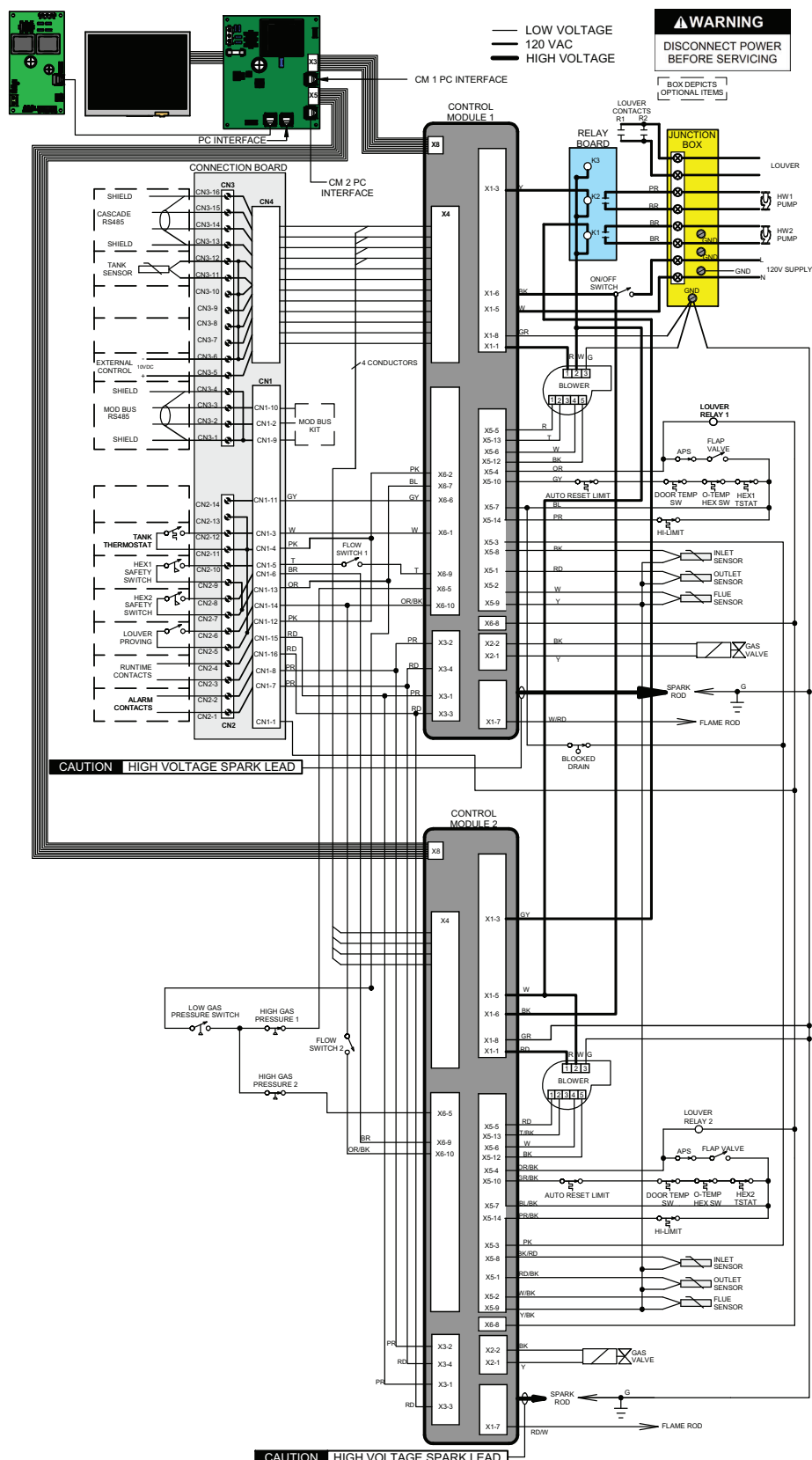

Notes:
 1. All wiring must be installed in accordance with local, state, provincial and national code requirements per either N.E.C. in USA or C.S.A. in Canada.
 2. If any original equipment wire as supplied with the system must be replaced, it must be replaced with wire having same wire gauge (AWG) and rated for a minimum of 105C. Exceptions: Replacement high voltage spark lead and ribbon cables must be purchased from the factory. Use of a non-approved spark lead or ribbon cables can lead to operational problems which could result in non-repairable damage to the integrated controller or other components.
 3. Actual connector block locations may vary from those shown on diagrams. Refer to actual components for proper connector block locations when using diagrams to troubleshoot unit.

Notes

Notes

Notes

Revision Notes: Revision A (ECO #C09645) initial release.

Revision B (ECO #C11435) reflects edits made to the inlet connections on page 4 and called out on the ratings page (page 6). Changed from 2 1/2" inlet connections to 2" inlet connections (R05572). Along with the removal of the CPVC starter piece reference on page 20 (R05565).

Revision C (ECO #C12382) reflects addition of the CSA Low Lead Content logo.

Revision D (ECO #C11814) reflects the addition of Metal Fab as an approved supplier.

Revision E (ECO #C13528) reflects the removal of the page number reference on page 15, the addition of the corrosive contaminant warning on page 3 (R06313), along with updating IMG00141 on page 35 (R06201).

Revision F (ECO #C14411) reflects changes made to Table 7A - Gas Piping Chart on page 38 (R6621), the addition of the corrosive contaminant warning on page 7 (R06313), along with the condensate trap changes (R6594).

Revision G (ECO #C14713) reflects high altitude updates.

Revision H (ECO #C15251) reflects the addition of the burner door temperature switch updates (R6322).

Revision I (ECO C16461) reflects the update of piping diagrams on pages 31 - 35.

Revision J (ECO #C16894) reflects the removal of temperature and pressure gauge information from the "How It Works" section on pages 4-5 (ECR R07715), the update of water content in the Ratings table on page 6 (ECR R07744), the regulation of pressure drop information on pages 37 and 38 and the addition of Grundfos pumps to Table 6B on page 30.

Revision K (Change #500000695) reflects the addition of ICC venting options on page 22 (R06799) along with edits made to the outlet sensor callout on page 4 (R07074).

Revision L (Change # 500001248) reflects the update of FIG. 6-2 on page 31 and FIG. 6-6 on page 35.

Revision M (PCP# 3000003998 / CN# 500004062) reflects a change to the Duravent Polypro Adapter number in Table 3E on page 21. SAP material numbers have been updated.

Revision N (PCP# 3000005143 / CN# 500006666) reflects the addition of new venting category information on pages 25 through 27.

Revision P (PCP# 3000004438 / CN# 500005574) reflects an update to the flue temperatures on page 54.

Revision R (PCP# 3000006133 / CN# 500007549) reflects the addition of a PVC-DWV vent fitting in Table 3C on page 20.

Revision T (PCP# 3000008814 / CN# 500008824) reflects changes in the water chemistry information on pages 33-38, 48, and 60.

Revision U (PCP# 3000009708 / CN# 500009498) reflects changes made to Table 6B on page 33 along with edits made to the *Note below the table.

Revision V (PCP #3000010783 / CN #500010520) reflects an update to the low water flow requirement information on pages 33 and 54.

Revision W (PCP #3000010953 / CN #5000010523) reflects an update to Table 6B on page 33.

Revision X (PCP #3000030779 / CN #500020179) reflects an update to the piping diagrams, Table 10A, and Table 12A.

Revision Y (PCP #3000035007 / CN #500023460) reflects an update to the ratings table.

Revision AA (PCP #3000045219 / CN #500032730) reflects an update to FIG. 4-4A - 4-4B and Tables 4C & 4D.