

# Copper-Fin®

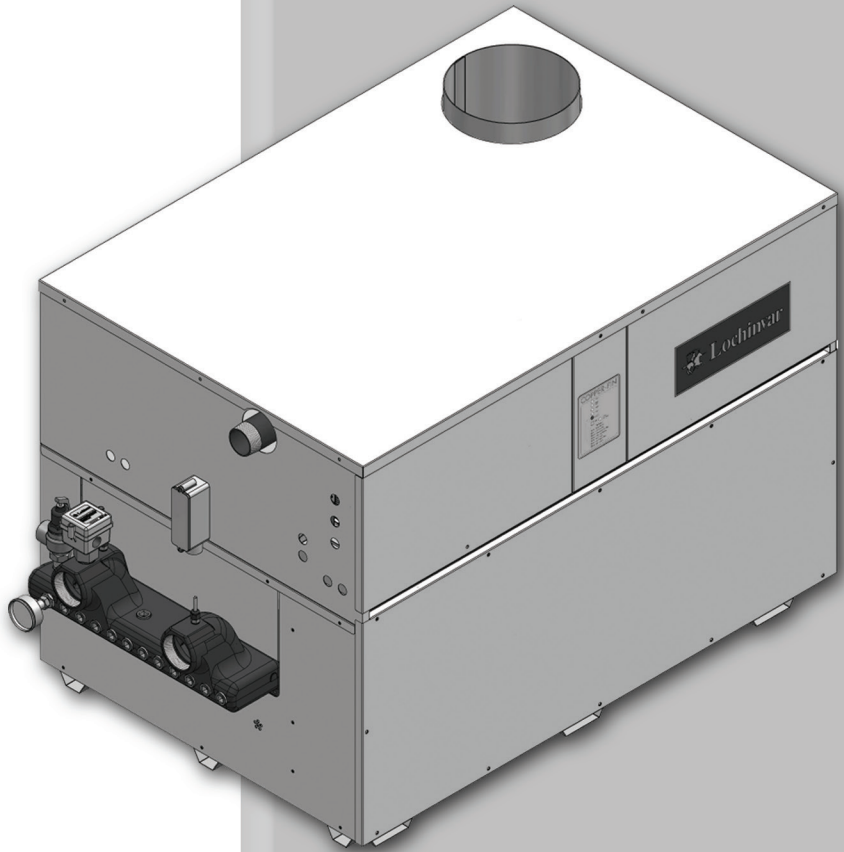
## Installation & Service Manual Models: 497 - 2067

**⚠ WARNING:** If the information in this manual is not followed exactly, a fire or explosion may result causing property damage, personal injury or loss of life.

-- This water heater **MUST NOT** be installed in any location where gasoline or flammable vapors are likely to be present.

### -- WHAT TO DO IF YOU SMELL GAS

- Do not try to light any appliance.
- Do not touch any electric switch; do not use any phone in your building.
- Immediately call your gas supplier from a near by phone. Follow the gas supplier's instructions.
- If you cannot reach your gas supplier, call the fire department.
- Installation and service must be performed by a qualified installer, service agency, or the gas supplier.



### ⚠ WARNING:

This manual supplies information for the installation, operation, and servicing of the appliance. It is strongly recommended that this manual be reviewed completely before proceeding with an installation. Perform steps in the order given. Failure to comply could result in severe personal injury, death, or substantial property damage.

Save this manual for future reference.

# Contents

HAZARD DEFINITIONS.....	2	Terminal Strip Connection Options .....	40-41
PLEASE READ BEFORE PROCEEDING.....	3-4	Temperature Controls	
SAFETY INFORMATION.....	4	Temperature Adjustment.....	41
THE COPPER-FIN -- HOW IT WORKS.....	5-7	Outdoor Reset Option.....	42
RATINGS.....	8-9	Temperature Control Sensors .....	43-44
1. DETERMINE UNIT LOCATION		Hot Surface Ignition System .....	45
Locating the Unit.....	10	Operation and Diagnostic Lights.....	46
Indoor Clearances from Combustible Construction .....	10	6. STARTUP	
Freeze Protection.....	11-12	Operating and Safety Instructions.....	47
Prevent Combustion Air Contamination.....	11-13	Check Water Chemistry .....	48
Combustion Air Options .....	14-15	Freeze Protection (when used).....	48
2. VENTING		Fill and Test Water System.....	49
General Venting Information .....	16-17	Purge Air from Water System .....	49
Vent System Options		Check for Gas Leaks / Thermostat Circuit(s).....	50
Conventional Negative Draft Venting .....	18-21	Check Vent and Air Piping.....	50
Masonry Chimney Installation and Inspection.....	19	Placing the Boiler in Operation .....	50
Outdoor Installation Options .....	22-23	7. DOMESTIC WATER HEATERS	
3. GAS CONNECTIONS		General.....	51
Connecting to Gas Supply .....	24	Water Velocity Control .....	51
Gas Pressure Test .....	24	Pipe Size Requirements	
Gas Piping.....	24	Typical Water Heater Piping w/ Storage Tank .....	52
Gas Connections / Gas Train and Controls.....	25	Single Water Heater Piping w/Two Storage Tanks ...	53
Combination Gas Valves.....	26	Multiple Water Heater Piping w/One Storage Tank ...	54
Checking Gas Supply Pressure .....	26-27	Multiple Water Heater Piping w/Multi. Storage Tanks ..	55
Gas Manifold Pressure Adjustment .....	27-28	Water Chemistry.....	56
4. WATER CONNECTIONS		Circulating Pump/ Performance .....	56
Inlet & Outlet Connections .....	29	Heat Exchanger .....	57
Relief Valve .....	29	Potable Hot Water Temperature Controls.....	57
Heating Boiler Installations.....	29-31	Location of Cold Water Supply Piping Connections .....	58
Low Temperature Return Water Systems.....	32	High Water Temperature Limit Control .....	59
Primary/Secondary Piping of a Single Boiler.....	33	Optional Relief Valve.....	59
Primary/Secondary Piping of Multiple Boilers .....	34	Thermal Expansion and Cathodic Protection.....	59
Boiler w/Low Temperature Bypass Piping.....	35	8. MAINTENANCE	
Primary/Secondary Piping with Buffer Tank.....	36	Burner Flames.....	60
Installation with a Chilled Water System.....	37	Burner Removal and Cleaning Procedures .....	60-61
Typical Heating Boiler Installations .....	37	Adjusting Differential Air Pressure .....	61-62
Boiler Flow Rate / Bypass Requirements .....	37-38	Servicing a Hot Surface Igniter / Ignition Module .....	63
Temperature/Pressure Gauge and Water Treatment .....	38	Sequence of Operation Overview .....	63-64
5. ELECTRICAL CONNECTIONS		9. GLOSSARY & NOTES .....	65-67
Connecting to Electrical Supply .....	39	10. DIAGRAMS .....	68-71
Line Voltage Connections.....	40	Revision Notes .....	Back Cover
EMS Connections .....	40		

## Hazard definitions

The following defined terms are used throughout this manual to bring attention to the presence of hazards of various risk levels or to important information concerning the life of the product.

- ⚠ DANGER** DANGER indicates an imminently hazardous situation which, if not avoided, will result in death or serious injury.
- ⚠ WARNING** WARNING indicates a potentially hazardous situation which, if not avoided, could result in death or serious injury.
- ⚠ CAUTION** CAUTION indicates a potentially hazardous situation which, if not avoided, may result in minor or moderate injury.
- CAUTION** CAUTION used without the safety alert symbol indicates a potentially hazardous situation which, if not avoided, may result in property damage.
- NOTICE** NOTICE indicates special instructions on installation, operation, or maintenance that are important but not related to personal injury or property damage.

## Please read before proceeding

### Special instructions

#### NOTICE

This is a gas appliance and should be installed by a licensed electrician and/or certified gas supplier. Service must be performed by a qualified service installer, service agency or the gas supplier.

#### ⚠ WARNING

If the information in these instructions is not followed exactly, a fire or explosion may result causing property damage, personal injury, or death.

This appliance **MUST NOT** be installed in any location where gasoline or flammable vapors are likely to be present, unless the installation is such to eliminate the probable ignition of gasoline or flammable vapors.

#### ⚠ WARNING

Improper installation, adjustment, alteration, service or maintenance can cause injury or property damage. Refer to this manual for assistance or additional information, consult a qualified installer, service agency or the gas supplier.

### Checking equipment –

Upon receiving equipment, check for signs of shipping damage. Pay particular attention to parts accompanying the appliances which may show signs of being hit or otherwise being mishandled. Verify total number of pieces shown on packing slip with those actually received. In case there is damage or a shortage, immediately notify the carrier.

**Do not use this appliance if any part has been under water. The possible damage to a flooded appliance can be extensive and present numerous safety hazards. Any appliance that has been under water must be replaced.**

The installer must verify that at least one carbon monoxide alarm has been installed within a residential living space or home following the alarm manufacturer's instructions and applicable local codes before putting the appliance into operation.

#### NOTICE

The ceramic fiber material used in this appliance is an irritant; when handling or replacing the ceramic materials it is advisable that the installer follow these safety guides.

#### REMOVAL OF COMBUSTION CHAMBER LINING OR BASE PANELS:

- Avoid breathing dust and contact with skin and eyes.
  - Use NIOSH certified dust respirator (N95). This type of respirator is based on the OSHA requirements for cristobalite at the time this document was written. Other types of respirators may be needed depending on the job site conditions. Current NIOSH recommendations can be found on the NIOSH website at <http://www.cdc.gov/niosh/homepage.html>. NIOSH approved respirators, manufacturers, and phone numbers are also listed on this website.

- Wear long-sleeved, loose fitting clothing, gloves, and eye protection.

- Apply enough water to the combustion chamber lining to prevent airborne dust.

- Remove the combustion chamber lining from the appliance and place it in a plastic bag for disposal.

- NIOSH stated First Aid:  
Eye: Irrigate immediately.  
Breathing: Fresh air.

#### ⚠ WARNING

The combustion chamber insulation in this appliance contains ceramic fiber material. Ceramic fibers can be converted to cristobalite in very high temperature applications. The International Agency for Research on Cancer (IARC) has concluded, "Crystalline silica in the form of quartz or cristobalite from occupational sources is carcinogenic to humans (Group 1)." Normal operating temperatures in this appliance are below the level to convert ceramic fibers to cristobalite. Abnormal operating conditions would have to be created to convert the ceramic fibers in this appliance to cristobalite.

The ceramic fiber material used in this appliance is an irritant; when handling or replacing the ceramic materials it is advisable that the installer follow these safety guidelines.

### Warranty –

Factory warranty (shipped with unit) does not apply to units improperly installed or improperly operated.

Experience has shown that improper installation or system design, rather than faulty equipment, is the cause of most operating problems.

1. Excessive water hardness causing a lime/scale build-up in the copper tube is not the fault of the equipment and is not covered under the manufacturer's warranty (see Water Treatment and Water Chemistry).
2. Excessive pitting and erosion on the inside of the copper tube may be caused by too much water velocity through the tubes and is not covered by the manufacturer's warranty (see Boiler Flow Rates and Temperature Rise for flow requirements).

## Please read before proceeding

### Safety information

#### ⚠ Owner warning –

The information contained in this manual is intended for use by qualified professional installers, service technicians, or gas suppliers.

#### NOTICE

Consult and follow all local Building and Fire Regulations and other Safety Codes that apply to this installation. Consult local gas utility company to authorize and inspect all gas and flue connections.

A gas appliance that draws combustion air from the equipment room where it is installed must have a supply of fresh air circulating around it during burner operation for proper gas combustion and proper venting.

#### ⚠ WARNING

Should overheating occur or the gas supply fail to shut off, do not turn off or disconnect the electrical supply to the pump. Instead, shut off the gas supply at a location external to the appliance.

#### Boiler water –

- Thoroughly flush the system to remove debris. Use an approved pre-commissioning cleaner (see Start-Up Section), without the boiler connected, to clean the system and remove sediment. The high-efficiency heat exchanger can be damaged by build-up or corrosion due to sediment. **NOTE:** Cleaners are designed for either new systems or pre-existing systems. Choose accordingly.

#### Freeze protection fluids –

- NEVER use automotive antifreeze. Use only inhibited propylene glycol solutions, which are specifically formulated for hydronic systems. Ethylene glycol is toxic and can attack gaskets and seals used in hydronic systems.

#### Codes –

The equipment shall be installed in accordance with those installation regulations in force in the local area where the installation is to be made. These shall be carefully followed in all cases. Authorities having jurisdiction shall be consulted before installations are made. In the absence of such requirements, the installation shall conform to the latest edition of the National Fuel Gas Code, ANSI Z223.1. Where required by the authority having jurisdiction, the installation must conform to American Society of Mechanical Engineers Safety Code for Controls and Safety Devices for Automatically Fired Boilers, ASME CSD-1. All boilers conform to the latest edition of the ASME Boiler and Pressure Vessel Code, Section IV. Where required by the authority having jurisdiction, the installation must comply with the Canadian Gas Association Code, CAN/CGA-B149.1 and/or B149.2 and/or local codes. This appliance meets the safe lighting performance criteria with the gas manifold and control assembly provided, as specified in the ANSI standards for gas-fired hot water boilers, ANSI Z21.13 and gas water heaters, ANSI Z21.10.3.

#### ⚠ WARNING

To minimize the possibility of serious personal injury, fire or damage to your unit, never violate the following safety rules.

1. This unit is only for use with the type of gas indicated on the rating plate.
2. If you smell gas
  - shut off gas supply
  - do not try to light any appliance
  - do not touch any electrical switch; do not use any phone in your building
  - immediately call your gas supplier from a neighbor's phone. Follow the gas supplier's instructions
  - if you cannot reach your gas supplier, call the fire department
3. Boilers and water heaters are heat producing appliances. To avoid damage or injury, do not store materials against the appliance or the vent-air intake system. Use proper care to avoid unnecessary contact (especially children) with the appliance and vent-air intake components.
4. Never cover your unit, lean anything against it, store trash or debris near it, stand on it or in any way block the flow of fresh air to your unit.
5. UNDER NO CIRCUMSTANCES MUST FLAMMABLE MATERIALS SUCH AS GASOLINE OR PAINT THINNER BE USED OR STORED IN THE VICINITY OF THIS APPLIANCE, VENT-AIR INTAKE SYSTEM OR ANY LOCATION FROM WHICH FUMES COULD REACH THE APPLIANCE OR VENT-AIR INTAKE SYSTEM.
6. Appliance surfaces become hot during operation. Be careful not to touch hot surfaces. Keep all adults, children, and animals away from operation of the hot unit. Severe burns can occur.
7. You must take adequate care to prevent scald injury when storing water at elevated temperatures for domestic use.
8. This unit must have an adequate supply of fresh air during operation for proper gas combustion and venting.
9. Make sure all exhaust venting is properly installed and maintained. Improper venting of this unit could lead to increased levels of carbon monoxide.
10. Do not use this boiler if any part has been under water. Immediately call a qualified service technician to replace the boiler. The possible damage to a flooded boiler can be extensive and present numerous safety hazards. Any appliance that has been under water must be replaced.
11. Do not alter this unit in any way. Any change to this unit or its controls can be dangerous.

## The Copper-fin - How it works...

### 1. Heat exchanger

The heat exchanger allows system water to flow through specially designed tubes for maximum heat transfer. The glass lined headers and copper fined tubing are encased in a jacket that contains the combustion process.

### 2. Inner combustion chamber door

The inner combustion chamber door is a galvanized steel door which allows access for service, maintenance, and removal of the heat exchanger from inside the combustion chamber.

### 3. Blower

The blower pulls in air and injects air into the individual burners along with gas from the gas manifold where the mix is burned in the combustion chamber.

### 4. Gas valve

The gas valve allows the proper amount of gas to pass into the burner for combustion. The gas valve is biased with pressure from the combustion chamber to assist in regulation of the gas flow.

### 5. System / tank temperature sensor (not shown)

When connected, this sensor can be used as a system sensor or a tank sensor.

### 6. Inlet temperature sensor

This sensor monitors inlet water temperature. If selected as the controlling sensor, the appliance will maintain the set point temperature based on the reading at this sensor.

### 7. Temperature and pressure gauge (boiler only)

The temperature and pressure gauge monitors the outlet temperature of the appliance as well as the system water pressure.

### 8. Diagnostic display

The diagnostic display consists of six (6) lamps used to show all the major steps of operation and control malfunctions.

### 9. Burner

The burner is a ported stainless steel construction which uses a gas air mix to operate at a fixed input. Banks of burners are turned on or off to vary the firing rate.

### 10. Water outlet (system supply)

The water outlet is a pipe connection that supplies water to the system with connections for a flow switch (see #25), a relief valve (see #22), and a temperature and pressure gauge (boilers only) (see #7).

### 11. Water inlet (system return)

The water inlet is a pipe connection that receives water from the system and delivers it to the heat exchanger.

### 12. Gas supply pipe

The gas supply pipe on this appliance is 1 1/4" diameter (Models 497 - 747) and 2" diameter (Models 987 - 2067) NPT. Please reference the National Fuel Gas Code charts for connection details.

### 13. Two-Stage Electronic Temperature Control

The electronic temperature control provides two-stage (high / low fire) operation by monitoring system demand.

### 14. Air intake

Fresh air for combustion is drawn through a filter provided at the air intake, located at either the rear or right side of the appliance.

### 15. Line voltage terminal strip

The line voltage terminal strip provides a location to connect all of the line voltage (120 VAC) contact points to the unit.

### 16. Low voltage connection board

The low voltage connection board provides a location to tie in all of the low voltage contacts to the appliance. This is where most of the external safety devices are connected to the unit such as the louver proving switch.

### 17. Front doors - upper and lower

The front doors provide access to the gas train as well as the blower, burners and other key components for service and maintenance.

### 18. Hot surface igniter (HSI)

The hot surface igniter is a device that is used to ignite the air/gas mixture as well as monitor the performance of the flame during operation. This device acts as a flame sense electrode.

### 19. Flame inspection window (sight glass)

The flame inspection windows, located on either side of the appliance, allow for visual inspection of the burners and flame during operation.

### 20. Gas shut off valve (downstream test cock)

The downstream test cock (when supplied) is in the gas train to ensure complete shut off of the gas to the burner in case of maintenance, inspection, or testing of the valve.

### 21. Manual high limit

Device that monitors the outlet water temperature to ensure safe operation. If the temperature exceeds its setting (field adjustable), it will break the control circuit, shutting the appliance down.

### 22. Relief valve

The relief valve is a safety device that ensures the maximum pressure of the appliance is not exceeded. Boilers operate on pressure only and are shipped from the factory at a rating of 50 PSI. Water heaters operate on temperature and pressure and are shipped standard as 150 PSI and 210°F (98.9°C).

### 23. Power switch

The power switch is used to engage and disengage power to the appliance on the 120 VAC circuit.

### 24. Air pressure switch

The air pressure switch is a safety device which ensures proper blower operation. The air pressure switch is wired in series with the low voltage control circuit in such a way that if the fan does not engage or shuts down prematurely the device will break the control circuit and the unit will shut down.

### 25. Flow switch

The flow switch is a safety device that ensures flow through the heat exchanger during operation. This appliance is low mass and should never be operated without flow. The flow switch makes contact when flow is detected and allows the unit to operate. If flow is discontinued during operation for any reason the flow switch will break the control circuit and the unit will shut down.

### 26. Drain port(s)

Location from which the heat exchanger can be drained.

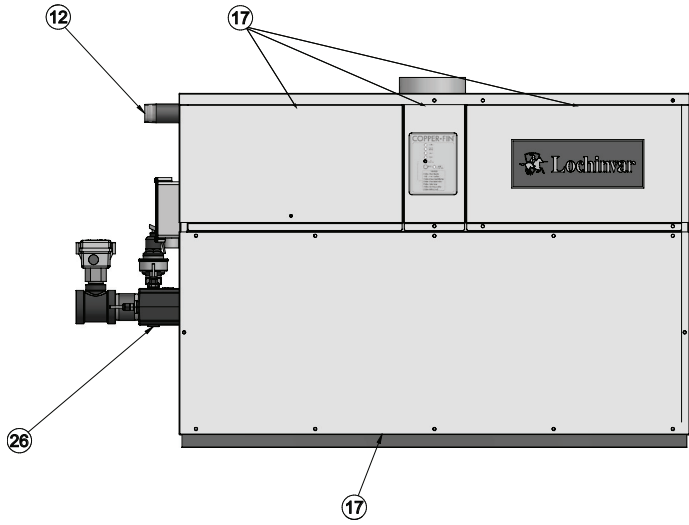
### 27. Manual shutoff valve (not shown)

Manual valve used to isolate the unit from the gas supply.

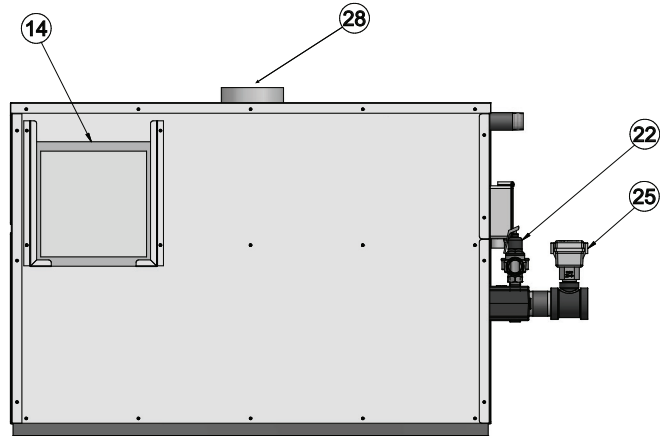
### 28. Flue pipe

A pipe like enclosure that is placed over an appliance to improve natural upward convection of heat and thereby increase the dissipating ability of the appliance.

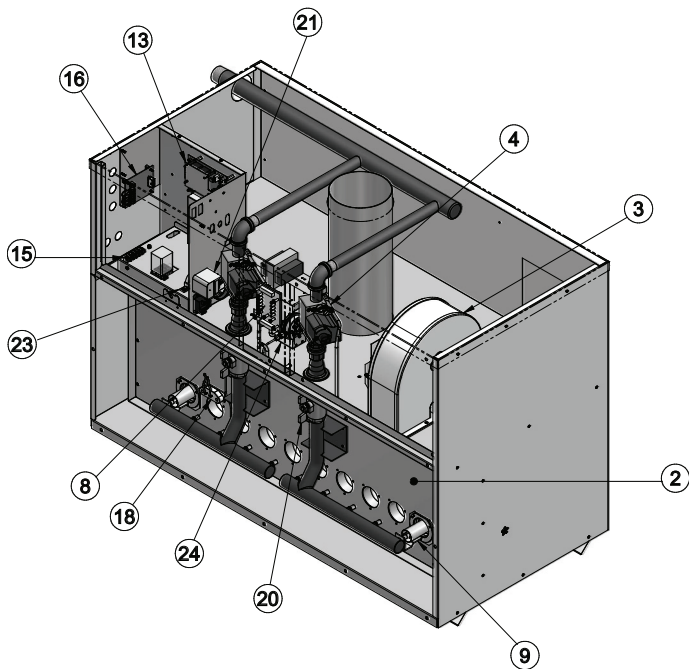
# The Copper-fin - How it works...



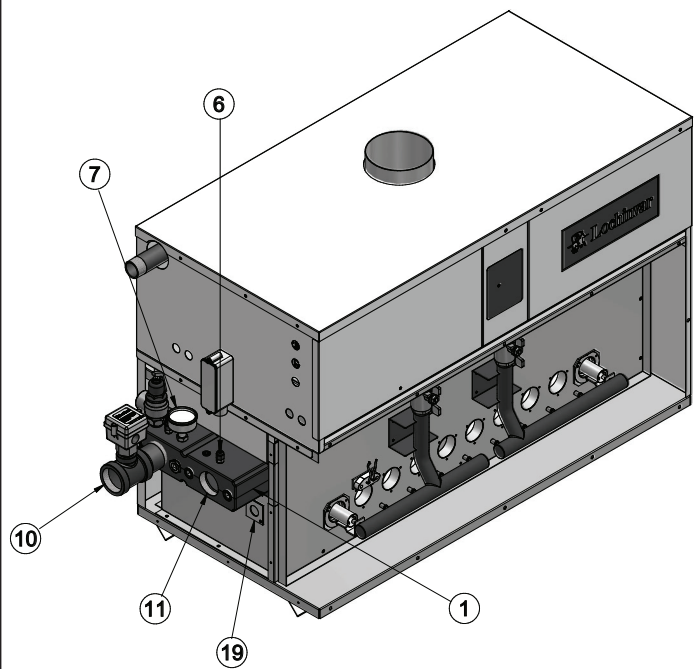
Models 497 - 747 Front View



Models 497 - 747 Rear View

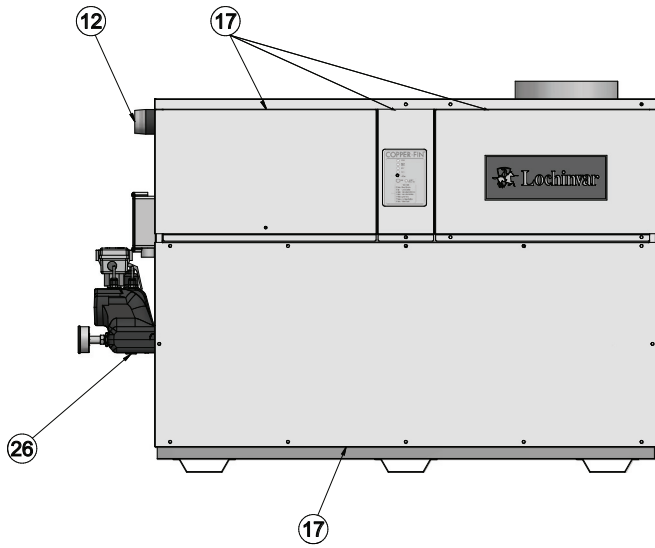


Models 497 - 747 Right Side (inside unit)

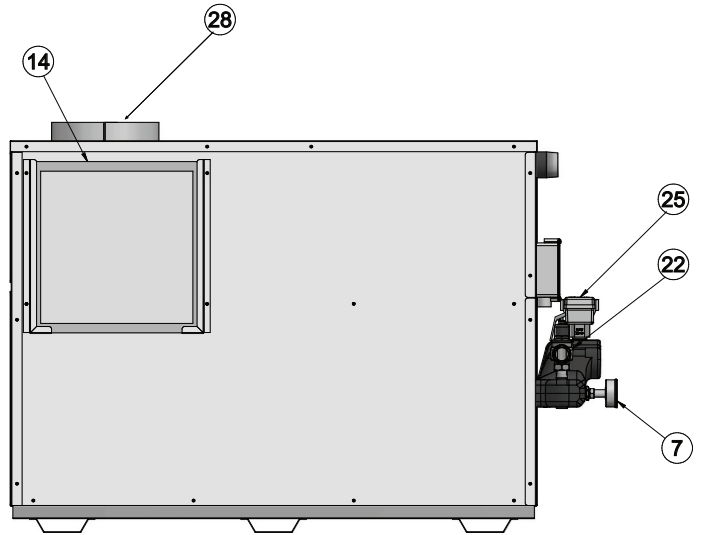


Models 497 - 747 Left Side (inside unit)

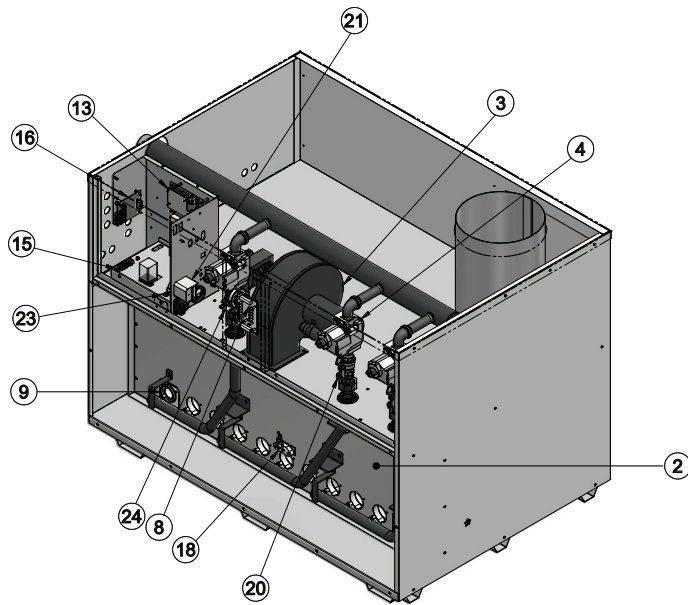
# The Copper-fin - How it works... *(continued)*



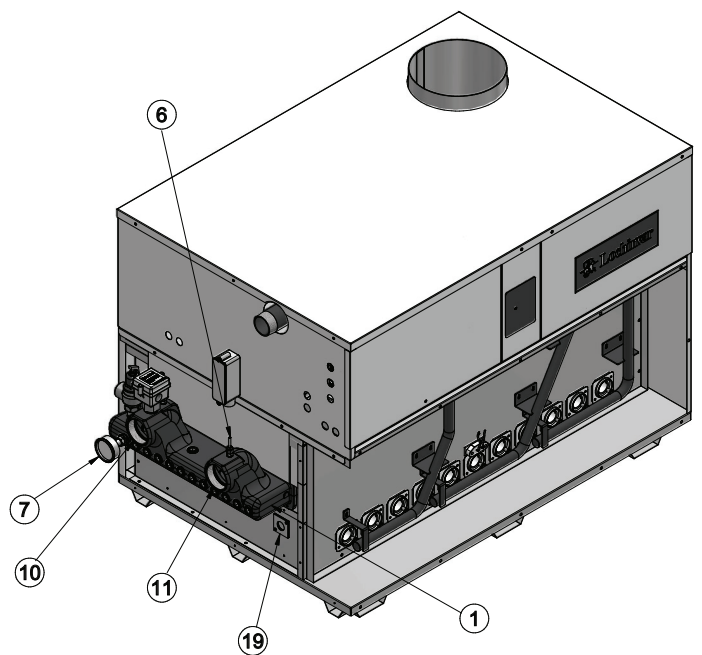
Models 987 - 2067 Front View



Models 987 - 2067 Rear View




Models 987 - 2067 Right Side (inside unit)



Models 987 - 2067 Left Side (inside unit)

## Ratings



 <b>Copper-fin AHRI Rating</b>					Other Specifications			
Model Number  Note: Change "N" to "L" for L.P. gas models.	Input MBH (Note 4)		Gross Output MBH (Note 1)	Net AHRI Ratings Water, MBH (Note 2)	Boiler Water Content Gallons	Water Connections	Gas Connections	Vent Size (Note 3)
	Min	Max						
CBN497	250	495	416	362	1.9	2"	1 1/4"	6"
CBN647	350	645	542	471	2.0	2"	1 1/4"	8"
CBN747	350	745	626	544	2.4	2"	1 1/4"	8"
CBN987	360	985	827	719	3.3	2 1/2"	2"	10"
CBN1257	720	1255	1054	917	3.5	2 1/2"	2"	12"
CBN1437	720	1435	1205	1048	3.7	2 1/2"	2"	12"
CBN1797	720	1795	1508	1311	4.1	2 1/2"	2"	14"
CBN2067	990	2065	1735	1508	4.3	2 1/2"	2"	14"

**NOTICE**

Maximum allowed working pressure is located on the rating plate.

**Notes:**

- The ratings are based on standard test procedures prescribed by the United States Department of Energy.
- Net AHRI ratings are based on net installed radiation of sufficient quantity for the requirements of the building and nothing need be added for normal piping and pickup. Ratings are based on a piping and pickup allowance of 1.15.
- Copper-fins require special gas venting. Use only the vent materials and methods specified in the Installation and Service Manual.
- The Copper-fin is orificed for operation up to 2000 feet altitude. The appliance will be derated 4% per 1000 feet above 2000 feet elevation. Consult the factory for installations above 2000 feet elevation.
- Ratings have been confirmed by AHRI.

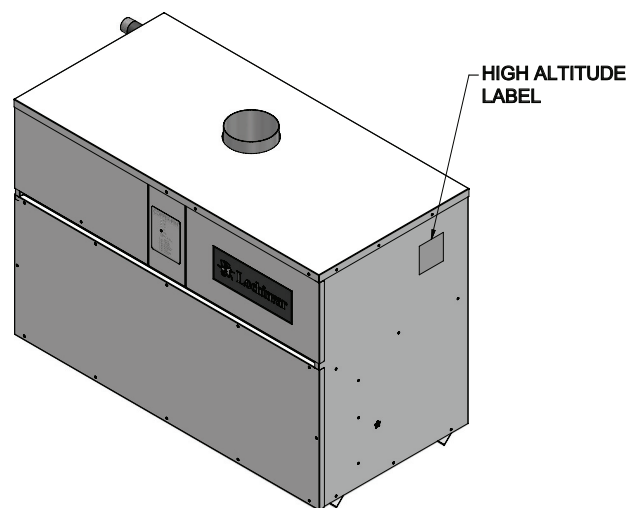


Figure A High altitude label location\_boiler

## Ratings *(continued)*

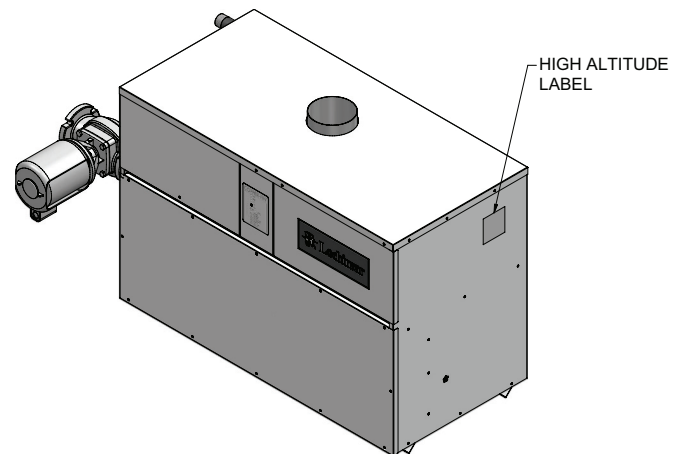


Copper-fin Specifications					
Model Number  Note: Change "N" to "L" for L.P. gas models	Input MBH	Water Content Gallons	Water Connections	Gas Connections	Vent Size  (Note 1)
CWN497	495	1.9	2"	1 1/4"	6"
CWN647	645	2.0	2"	1 1/4"	8"
CWN747	745	2.4	2"	1 1/4"	8"
CWN987	985	3.3	2 1/2"	2"	10"
CWN1257	1255	3.5	2 1/2"	2"	12"
CWN1437	1435	3.7	2 1/2"	2"	12"
CWN1797	1795	4.1	2 1/2"	2"	14"
CWN2067	2065	4.3	2 1/2"	2"	14"

**NOTICE** Maximum allowed working pressure is located on the rating plate.

### Notes:

1. Copper-fins require special gas venting. Use only the vent materials and methods specified in the Installation and Service Manual.
2. The Copper-fin is orificed for operation up to 2000 feet altitude. The appliance will be derated 4% per 1000 feet above 2000 feet elevation. Consult the factory for installations above 2000 feet elevation.



**Figure B** High altitude label location\_water heater

# 1 Determine unit location

## Installation

This unit meets the safe lighting performance criteria with the gas manifold and control assembly provided, as specified in the ANSI standards for gas-fired units. ANSI Z21.13/CSA 4.9 and ANSI Z21.10.3/CSA 4.3.

### Locating the unit

1. Maintain all clearances from combustible construction when locating unit. See Clearances from Combustible Construction, this page.
2. Locate the unit so that if water connections should leak, water damage will not occur. When such locations cannot be avoided, install a suitable drain pan that is well-drained under the unit. The pan must not restrict combustion air flow. The appliance manufacturer is not responsible for water damage in connection with this unit, or any of its components.
3. Install indoor units so that the ignition system components are protected from any water while operating or during service.
4. Appliances located in a residential garage and in adjacent spaces that open to the garage and are not part of the living space of a dwelling unit must be installed so that all burners and burner ignition devices have a minimum clearance of not less than 18" (46cm) above the floor. The appliance must be located or protected so that it is not subject to physical damage by a moving vehicle.
5. DO NOT install this appliance in any location where gasoline or flammable vapors are likely to be present.
6. The appliance must be installed on a level surface.
7. Models 497 - 747 are approved for installation on combustible flooring using the approved combustible floor kits (reference Table 1A). Models 987 - 2067 are approved for installation on combustible flooring. Do not install appliances directly on carpeting.
8. For outdoor models, you must install an optional vent kit. Instructions for mounting the vent kit are included in the venting section. Do not install outdoor models directly on the ground. You must install the outdoor unit on a concrete, brick, block, or other non-combustible pad. Outdoor models have additional special location and clearance requirements. See Outdoor Installation Venting, page 22. A wind proof cabinet protects the unit from weather.

## Indoor clearances from combustible construction

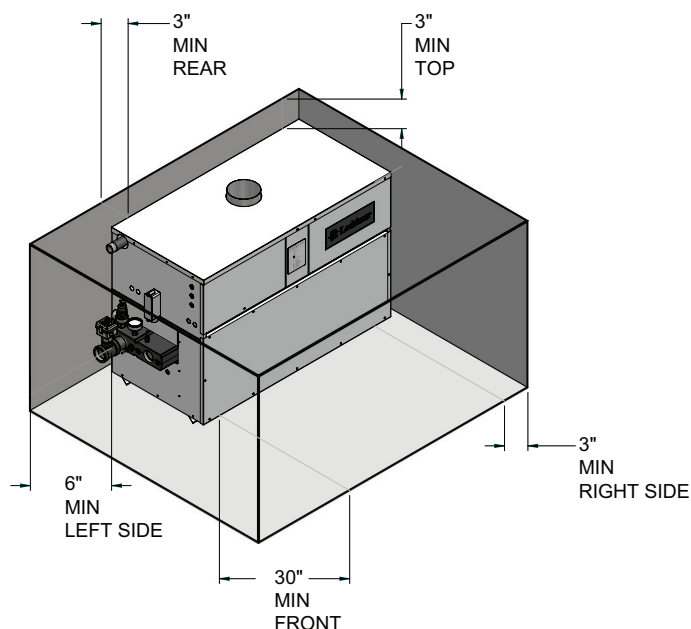
Maintain minimum specified clearances for adequate operation. Allow sufficient space for servicing pipe connections, pump and other auxiliary equipment, as well as the unit. See rating plate for specific service clearance requirements.

<b>Right Side</b>	3" (7.5 cm)
<b>Rear</b>	3" (7.5 cm) (3" min. from any surface)*
<b>Left Side</b>	6" (15 cm) (24" (0.61 m) suggested for service)
<b>Front</b>	Alcove* (30" (0.76m) suggested for service)
<b>Top</b>	3" (7.5 cm)
<b>Flue</b>	1" (25.4 mm)
<b>Hot Water Pipes</b>	1" (25.4 mm)

\*An Alcove is a closet without a door. Thirty-six inches (36") to rear required for outdoor installation.

**Note:** No additional clearance is needed on the right side of the unit for the observation port. An observation port is located on both the right and left side of the unit.

**Figure 1-1** Indoor clearances from combustible construction



# 1 Determine unit location *(continued)*

**TABLE 1A**  
**COMBUSTIBLE FLOOR KITS**

Model	Kit Number
497	100136977
647	100136978
747	100136979

## Freeze protection

Although these units are CSA International design-certified for outdoor installations, such installations are not recommended in areas where the danger of freezing exists. You must provide proper freeze protection for outdoor installations, units installed in unheated mechanical rooms or where temperatures may drop to the freezing point or lower. If freeze protection is not provided for the system, a low ambient temperature alarm is recommended for the mechanical room. Damage to the unit by freezing is non-warrantable.

Anytime the temperature measured at any of the sensors (except the outside air temperature sensor) drops below 40°F, the control turns on the pump contact and the alarm relay. The pump will shut off when both sensors are above 50°F.

## Pump operation

This unit is equipped with a pump delay of 30 seconds. If continuous operation of the pump is desired, the pump must be electrically connected to another circuit. Connection of the pump to this unit will provide intermittent pump delay operation.

## Location

Locate indoor boilers and water heaters in a room having a temperature safely above freezing [32°F (0°C)].

### CAUTION

A mechanical room operating under a negative draft pressure may experience a down draft in the flue of a boiler when it is not firing. The cold outside air pulled down the flue may freeze a heat exchanger. This condition must be corrected to provide adequate freeze protection.

## Hydronic systems anti-freeze

Freeze protection for a heating boiler or hot water supply boiler using an indirect coil can be provided by using hydronic system antifreeze. Follow the appliance manufacturers instructions. Do not use undiluted or automotive type antifreeze.

## Outdoor boiler installation

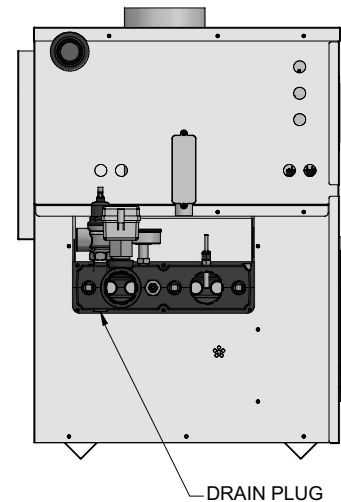
Adequate hydronic system antifreeze must be used. A snow screen should be installed to prevent snow and ice accumulation around the unit or its venting system.

## Shut-down and draining

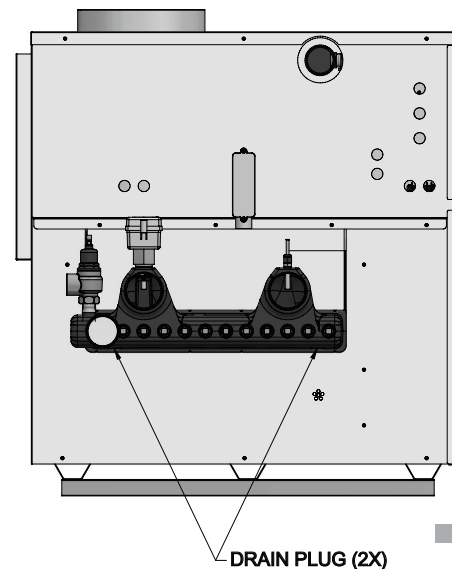
If for any reason, the unit is to be shut off, the following precautionary measures must be taken:

1. Shut off gas supply.
2. Shut off water supply.
3. Shut off electrical supply
4. Drain the unit completely. Remove one threaded plug or bulbwell from the inlet side of the front header and one from the outlet side of the front header on the heat exchanger. Blow all water out of the heat exchanger (see FIG.'s 1-2A and 1-2B).
5. Drain pump and piping.

**Figure 1-2A** *Drain the unit\_Models 497 - 747*



**Figure 1-2B** *Drain the unit\_Models 987 - 2067*



# 1 Determine unit location

## Freeze Protection for a Heating Boiler System (if required)

### ⚠ WARNING

Do not use undiluted or automotive type anti-freeze.

1. Use only properly diluted inhibited glycol anti-freeze designed for hydronics systems. Inhibited propylene glycol is recommended for systems where incidental contact with drinking water is possible.
2. A solution of 50% antifreeze will provide maximum protection of approximately -30°F.
3. Follow the instructions from the antifreeze manufacturer. Quantity of antifreeze required is based on total system volume including expansion tank volume.
4. Glycol is denser than water and changes the viscosity of the system. The addition of glycol will decrease heat transfer and increase frictional loss in the boiler and related piping. A larger pump with more capacity (15% to 25% more) may be required to maintain desired flow rates and prevent a noise problem in a glycol system.
5. Local codes may require a back flow preventer or actual disconnect from city water supply when antifreeze is added to the system.

## Combustion and Ventilation Air

Provisions for combustion and ventilation air must be in accordance with Section 5.3, Air for Combustion and Ventilation, of the latest edition of the National Fuel Gas Code, ANSI Z223.1, in Canada, the latest edition of CAN/CGA-B149 Installation Code for Gas Burning Appliances and Equipment, or applicable provisions of the local building codes.

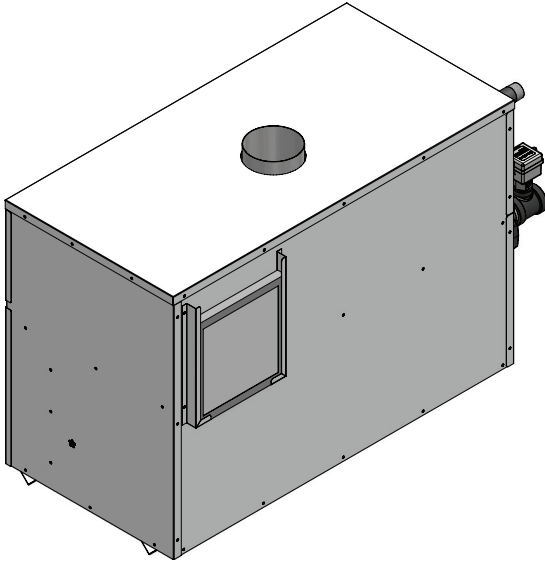
Provide properly-sized openings to the equipment room to assure adequate combustion air and proper ventilation when the unit is installed with conventional venting or sidewall venting.

\*Outside air openings shall directly communicate with the outdoors. When combustion air is drawn from the outside through a duct, the net free area of each of the two openings must have twice (2 times) the free area required for Outside Air/2 Openings. The above requirements are for the boiler only; additional gas fired appliances in the equipment room will require an increase in the net free area to supply adequate combustion air for all appliances.

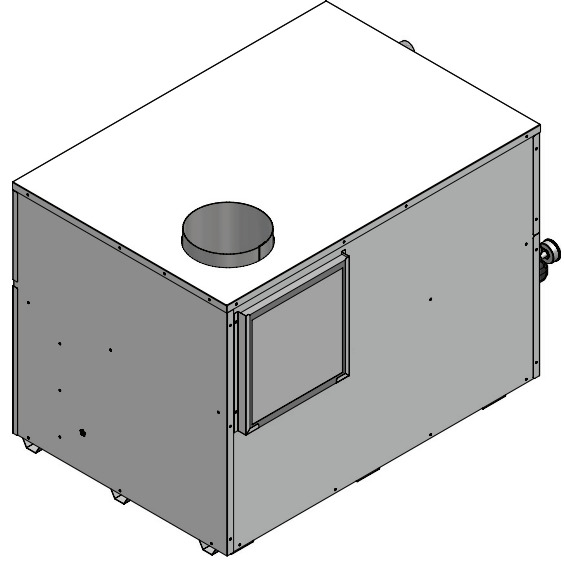
**TABLE 1B**  
MINIMUM RECOMMENDED COMBUSTION  
AIR SUPPLY TO EQUIPMENT ROOM

Model Number	*Outside Air from 2 Openings Directly from Outdoors		*Outside Air from 1 Opening Directly from Outdoors, in <sup>2</sup>	Inside Air from 2 Ducts Delivered from Outdoors		Inside Air from 2 Ducts Delivered from Interior Space	
	Top Opening, in <sup>2</sup>	Bottom Opening, in <sup>2</sup>		Top Opening, in <sup>2</sup>	Bottom Opening, in <sup>2</sup>	Top Opening, in <sup>2</sup>	Bottom Opening, in <sup>2</sup>
497	125 (806 cm <sup>2</sup> )	125 (806 cm <sup>2</sup> )	167 (1077 cm <sup>2</sup> )	250 (1613 cm <sup>2</sup> )	250 (1613 cm <sup>2</sup> )	500 (3226 cm <sup>2</sup> )	500 (3226 cm <sup>2</sup> )
647	163 (1052 cm <sup>2</sup> )	163 (1052 cm <sup>2</sup> )	217 (1400 cm <sup>2</sup> )	325 (2097 cm <sup>2</sup> )	325 (2097 cm <sup>2</sup> )	650 (4194 cm <sup>2</sup> )	650 (4194 cm <sup>2</sup> )
747	188 (1213 cm <sup>2</sup> )	188 (1213 cm <sup>2</sup> )	250 (1613 cm <sup>2</sup> )	375 (2420 cm <sup>2</sup> )	375 (2420 cm <sup>2</sup> )	750 (4839 cm <sup>2</sup> )	750 (4839 cm <sup>2</sup> )
987	248 (1600 cm <sup>2</sup> )	248 (1600 cm <sup>2</sup> )	330 (2129 cm <sup>2</sup> )	495 (3194 cm <sup>2</sup> )	495 (3194 cm <sup>2</sup> )	990 (6388 cm <sup>2</sup> )	990 (6388 cm <sup>2</sup> )
1257	315 (2032 cm <sup>2</sup> )	315 (2032 cm <sup>2</sup> )	420 (2710 cm <sup>2</sup> )	630 (4065 cm <sup>2</sup> )	630 (4065 cm <sup>2</sup> )	1260 (8130 cm <sup>2</sup> )	1260 (8130 cm <sup>2</sup> )
1437	360 (2323 cm <sup>2</sup> )	360 (2323 cm <sup>2</sup> )	480 (3097 cm <sup>2</sup> )	720 (4646 cm <sup>2</sup> )	720 (4646 cm <sup>2</sup> )	1440 (9291 cm <sup>2</sup> )	1440 (9291 cm <sup>2</sup> )
1797	450 (2903 cm <sup>2</sup> )	450 (2903 cm <sup>2</sup> )	600 (3871 cm <sup>2</sup> )	900 (5807 cm <sup>2</sup> )	900 (5807 cm <sup>2</sup> )	1800 (11614 cm <sup>2</sup> )	1800 (11614 cm <sup>2</sup> )
2067	518 (3342 cm <sup>2</sup> )	518 (3342 cm <sup>2</sup> )	690 (4452 cm <sup>2</sup> )	1035 (6678 cm <sup>2</sup> )	1035 (6678 cm <sup>2</sup> )	2070 (13356 cm <sup>2</sup> )	2070 (13356 cm <sup>2</sup> )

# 1 Determine unit location *(continued)*



**Figure 1-3**\_Combustion air filter\_ Models 497 - 747



**Figure 1-4**\_Combustion air filter\_ Models 987 - 2067

## NOTICE

During construction the air filter should be checked more frequently to ensure it does not become clogged with construction dirt and debris.

## CAUTION

Sustained operation of an appliance with a clogged burner may result in nuisance operational problems, bad combustion, and non-warrantable component failures.

### Combustion air filter

This unit has a standard air filter located at the combustion air inlet. This filter helps ensure clean air is used for the combustion process. Check this filter every month and replace when it becomes dirty. The filter size on Models 497 - 747 is 12" x 12" x 1" (30.5cm x 30.5cm x 2.5cm) and 16" x 16" x 1" (40.6cm x 40.6cm x 2.5 cm) on Models 987 - 2067. You can find these commercially available filters at any home center or HVAC supply store.

# 1 Determine unit location

## Combustion Air Options

### ⚠ CAUTION

Under no circumstances should a mechanical room ever be under a negative pressure. Particular care should be taken when exhaust fans, clothes dryers, compressors, air handling units, etc., take away air from the inlet.

This unit has four combustion air options.

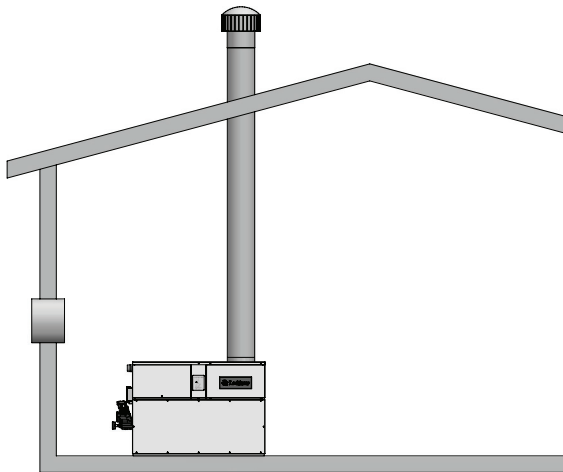
### 1. Outside Combustion Air, No Ducts

You can direct outside combustion air to this unit using either one or two permanent openings (see FIG. 1-5).

#### One Opening

The opening must have a minimum free area of one square inch per 3000 Btu input (7 cm<sup>2</sup> per kW). You must locate this opening within 12" (30 cm) of the top of the enclosure.

**Figure 1-5\_** Outside combustion air single opening

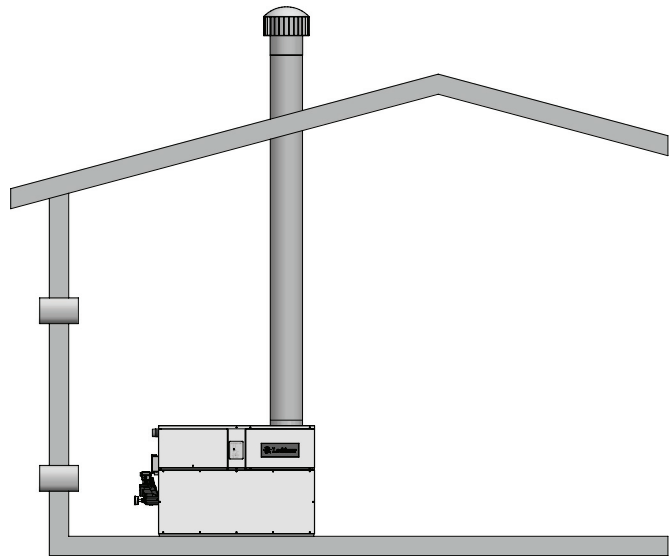


#### Two Openings

The combustion air opening must have a minimum free area of one square inch per 4000 Btu input (5.5cm<sup>2</sup> per kW). You must locate this opening within 12" (30cm) of the bottom of the enclosure.

The ventilation air opening must have a minimum free area of one square inch per 4000 Btu input (5.5cm<sup>2</sup> per kW). You must locate this opening within 12" (30cm) of the top of the enclosure.

**Figure 1-6\_** Outside combustion air, two openings

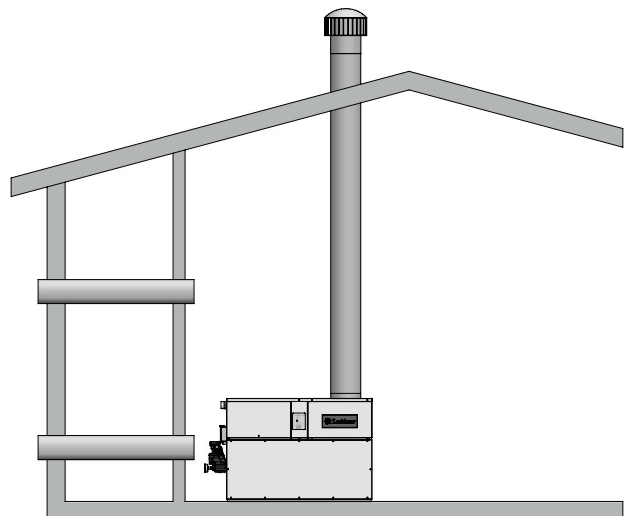


### 2. Outside Combustion Air, Using Ducts

You can direct outside combustion air to this unit using two air ducts to deliver the air to the boiler room.

Each of the two openings must have a minimum free area of one square inch per 2000 Btu input (11cm<sup>2</sup> per kW).

**Figure 1-7\_** Outside combustion air, using ducts

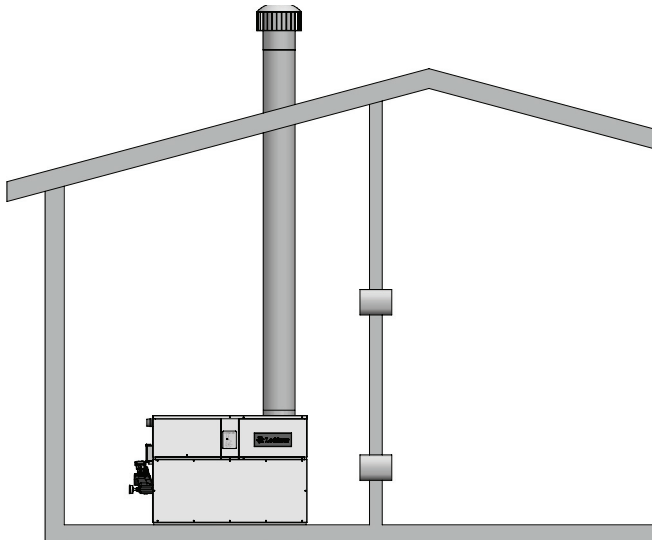


# 1 Determine unit location *(continued)*

## 3. Combustion Air from an Interior Space

You can direct combustion air to this unit using air from an adjoining interior space. You must provide two openings from the boiler room to the adjoining room. Each of the two openings must have a net free area of one square inch per 1000 Btu input (22cm<sup>2</sup> per kW), but not less than 100 square inches (645cm<sup>2</sup>).

**Figure 1-8** *Combustion air from an interior space*



All dimensions are based on net free area in square inches. Metal louvers or screens reduce the free area of a combustion air opening a minimum of approximately 25%. Check with louver manufacturers for exact net free area of louvers. Where two openings are provided, one must be within 12" (30 cm) of the ceiling and one must be within 12" (30 cm) of the floor of the equipment room. Each opening must have a minimum net free area as specified in TABLE 1B, page 12. Single openings shall be installed within 12" (30 cm) of the ceiling.

### CAUTION

The combustion air supply must be completely free of any flammable vapors that may ignite or chemical fumes which may be corrosive to the appliance. Common corrosive chemical fumes which must be avoided are fluorocarbons and other halogenated compounds, most commonly present as refrigerants or solvents, such as Freon, trichlorethylene, perchlorethylene, chlorine, etc. These chemicals, when burned, form acids which quickly attack the heat exchanger finned tubes, headers, flue collectors, and the vent system. The result is improper combustion and a non-warrantable, premature unit failure.

## Exhaust Fans

### ⚠ WARNING

Any fan or equipment which exhausts air from the boiler room may deplete the combustion air supply and/or cause a down draft in the venting system. Spillage of flue products from the venting system into an occupied living space can cause a very hazardous condition that must be corrected immediately. If a fan is used to supply combustion air to the boiler room, the installer must make sure that it does not cause drafts which could lead to nuisance operational problems with the boiler.

## 2 Venting

### General information

You must supply adequate combustion and ventilation air to this unit. You must provide minimum clearances for the vent terminal from adjacent buildings, windows that open, and building openings. Follow all requirements set forth in the latest edition of the National Fuel Gas Code, ANSI Z223.1, in Canada, the latest edition of CAN/CGA Standard B149 Installation Code for Gas Burning Appliances and Equipment or applicable local building codes. Vent installations for connection to gas vents or chimneys must be in accordance with Part 7, "Venting of Equipment" of the above-mentioned standards.

#### NOTICE

Examine the venting system at least once each year. Check all joints and vent pipe connections for tightness. Also check for corrosion or deterioration. If you find any problems, correct them at once.

#### ⚠ DANGER

Failure to use correct venting materials can result in loss of life from flue gas spillage into working or living space.

Vent system must be gas tight sealed to the appliance vent outlet (i.e., silicone) for all venting configurations. Failure to follow this warning can cause flue products to leak into the cabinet causing damage to the appliance and can result in gas spillage into the living or work space causing personal injury or death. See FIG. 2-5.

### Venting support

Support horizontal portions of the venting system to prevent sagging. Provide an upward slope of at least 1/4 inch per foot (21mm/m) on all horizontal runs from the unit to the vertical flue run or to the vent terminal on sidewall venting installations.

Do not use an existing chimney as a raceway if another appliance or fireplace is vented through the chimney. A water heater shall not be connected to a chimney flue serving a separate appliance designed to burn solid fuel. The weight of the venting system must not rest on the unit. Provide adequate support of the venting system. Follow all local and applicable codes. Secure and seal all vent connections. Follow the installation instructions from the vent material manufacturer.

### Vertical vent termination clearances and location

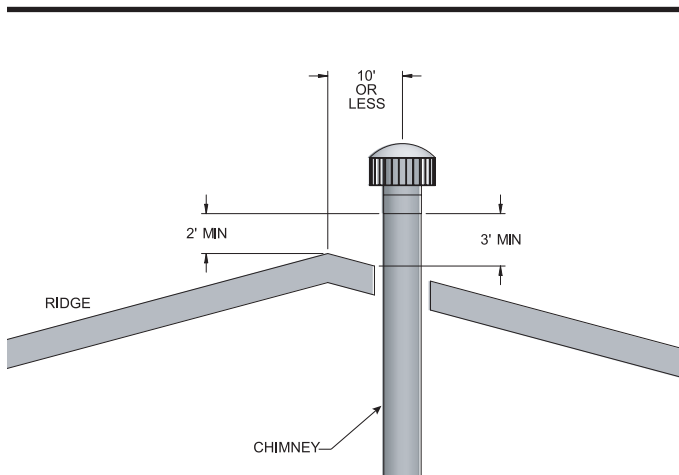
The vent terminal should be vertical and exhaust outside the building at least 2 feet (0.61m) above the highest point of the roof within a 10 foot (3.05m) radius of the termination.

The vertical termination must be a minimum of 3 feet (0.91m) above the point of exit.

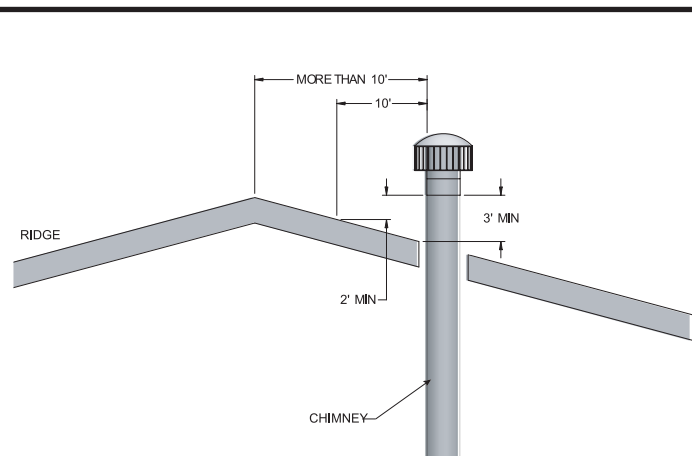
A vertical termination less than 10 feet (3.05m) from a parapet wall must be a minimum of 2 feet (0.61m) higher than the parapet wall.

You must locate the air inlet termination elbow at least 12" (30cm) above the roof or above normal snow levels.

Keep the vent cap clear of snow, ice, leaves, and debris to avoid blocking the flue.



**Figure 2-1\_Vent termination from peaked roof - 10 ft. or less from ridge**

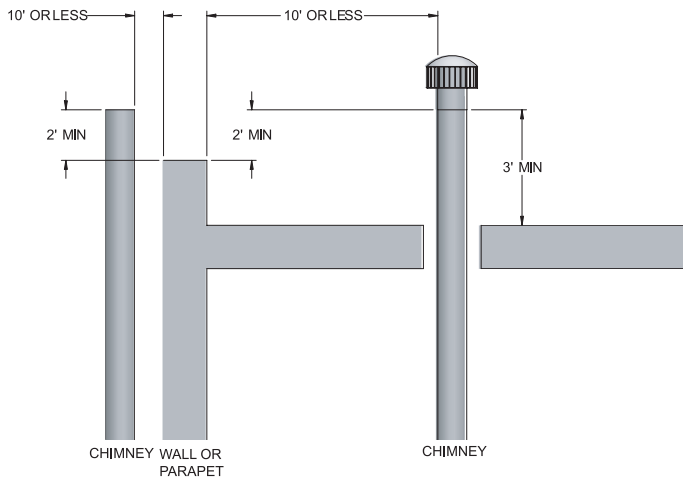


**Figure 2-2\_Vent termination from peaked roof - 10 ft. or more from ridge**

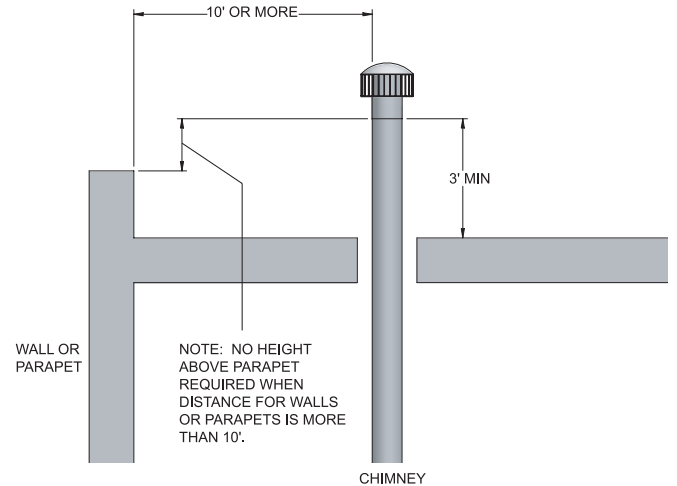
#### NOTICE

Vent terminations are not shown in FIG.'s 2-1 thru 2-4. Make sure all vertical vents are installed with vent terminations recommended by the vent manufacturer.

## 2 Venting (continued)



**Figure 2-3** Vent termination from flat roof - 10 ft. or less from parapet wall



**Figure 2-4** Vent termination from flat roof - 10 ft. or more from parapet wall

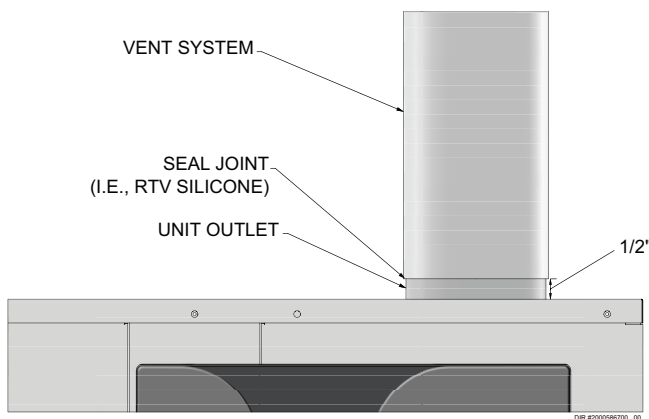
**CAUTION**

Units which are shut down or will not operate may experience freezing due to convective air flow in flue pipe, through the air inlet, or from negative pressure in the equipment room. In cold climates, operate pump continuously to help prevent freezing of boiler water. Provide proper freeze protection. See Freeze Protection, page 48.

TABLE 2A FLUE PIPE SIZES			
MODEL	FLUE SIZE	MODEL	FLUE SIZE
497	6"	1257	12"
647	8"	1437	12"
747	8"	1797	14"
987	10"	2067	14"

Installer may increase diameter one pipe size for ease of installation, if needed.

**Figure 2-5** Vent system must be sealed



### Vent system options

#### Vent System Options

This fan-assisted Category 1 unit has two venting options.

1. Conventional Negative Draft Venting  
This option uses a vertical rooftop flue termination. Combustion air is supplied from the mechanical room. See page 15 for detailed information.
2. Outdoor Installation Venting  
This option uses the installation of special air inlet and vent caps on the unit.

All units are shipped from the factory equipped for conventional negative draft venting. All other optional vent systems require the installation of specific vent kits and venting materials. The following is a detailed explanation of the installation requirements for each venting system, components used and part numbers of vent kits for each model.

## 2 Venting

### Barometric damper location

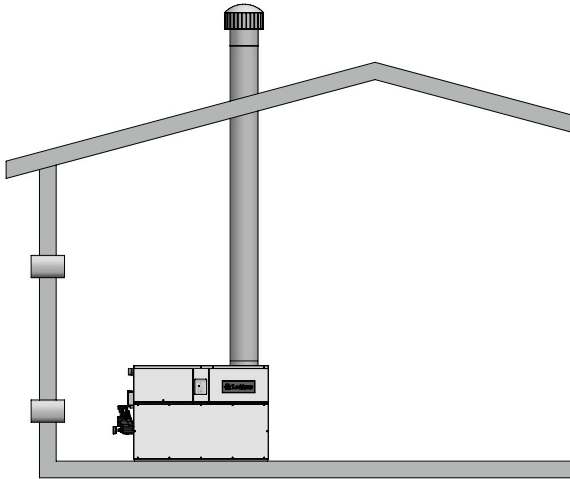
Any venting system option that requires a barometric damper must adhere to the following directions for optimum performance. The preferred location for the barometric damper is in a tee or collar installed in the vertical pipe rising from the unit's flue outlet. The barometric damper **MUST NOT** be installed in a bull head tee installed on the unit's flue outlet. The tee or collar containing the barometric damper should be approximately three feet vertically above the connection to the unit's flue outlet. This location ensures that any positive velocity pressure from the unit's internal combustion fan is dissipated and the flue products are rising due to buoyancy generated from the temperature of the flue products. Adjust the weights on the damper to ensure that draft is maintained within the specified ranges.

### 1. Conventional negative draft venting

#### NOTICE

Before installing a venting system, follow all venting clearances and requirements found in the Venting, General Information section, page 16.

**Figure 2-6** Conventional negative draft vertical venting with combustion air louvers



On a conventionally vented, negative draft appliance, the connection from the vent to the chimney or vent termination on the outside of the building **MUST** be made with listed Type "B" double wall (or equivalent) vent connectors and must be direct as possible with no reduction in diameter. To properly size all double wall vent connectors and stacks, use the venting tables in the latest edition of the National Fuel Gas Code, ANSI Z223.1, in Canada, the latest edition of CGA Standard B149 Installation Code for Gas Burning Appliances and Equipment. The Type "B" vent and accessories, such as firestop spacers, thimbles, caps, etc., **MUST** be installed in accordance with the manufacturer's listing. The vent connector and firestop must provide correct spacing to combustible surfaces and seal to the vent connector on the upper and lower sides of each floor or ceiling through which the vent connector passes.

Any vent materials used must be listed by a nationally recognized test agency for use as vent material.

### Negative draft

The negative draft in a conventional vent installation must be within the range of 0.02 to 0.08 inches w.c. to ensure proper operation. Make all draft readings while the unit is in stable operation (approximately 2 to 5 minutes).

Connect the flue vent directly to the flue outlet opening on the top of the unit. No additional draft diverter or barometric damper is needed on single unit installations with a dedicated stack and a negative draft within the specified range of 0.02 to 0.08 inches w.c. If the draft in a dedicated stack for a single unit installation exceeds the maximum specified draft, you must install a barometric damper to control draft. Multiple unit installations with combined venting or common venting with other Category I negative draft appliances require each boiler to have a barometric damper installed to regulate draft within the proper range.

Do not connect vent connectors serving appliances vented by natural draft (negative draft) to any portion of a mechanical draft system operating under positive pressure. Connecting to a positive pressure stack may cause flue products to be discharged into the living space causing serious health injury.

### Flue outlet piping

The negative draft in a conventional vent installation must be within the range of 0.02 to 0.08 inches w.c. to ensure proper operation. Make all draft readings while the unit is in stable operation (approximately 2 to 5 minutes).

Connect the flue vent directly to the flue outlet opening on the top of the unit. No additional draft diverter or barometric damper is needed on single unit installations with a dedicated stack and a negative draft within the specified range of 0.02 to 0.08 inches w.c.

### Common venting systems

You can combine the flue with the vent from any other negative draft, Category I appliance. Using common venting for multiple negative draft appliances requires you to install a barometric damper with each unit. This will regulate draft within the proper range. You must size the common vent and connectors from multiple units per the venting tables for Type-B double-wall vents in the latest edition of the National Fuel Gas Code, ANSI Z223.1 and/or CAN/CGA-B149 Installation Code.

Common venting systems may be too large when an existing unit is removed.

## 2 Venting *(continued)*

Common venting systems may be too large when an existing unit is removed.

At the time of removal of an existing appliance, the following steps shall be followed with each appliance remaining connected to the common venting system placed in operation, while other appliances remaining connected to the common venting system are not in operation.

1. Seal any unused opening in the common venting system.
2. Visually inspect the venting system for proper size and horizontal pitch. Make sure there is no blockage or restriction, leakage, corrosion and other unsafe conditions.
3. If possible, close all building doors and windows. Close all doors between the space in which the appliances remaining connected to the common venting system are located and other building spaces.
4. Turn on clothes dryers and any other appliances not connected to the common venting system. Turn on any exhaust fans, such as range hoods and bathroom exhausts, so they will operate at maximum speed. Do not operate a summer exhaust fan.
5. Close fire place dampers.
6. Place in operation the unit being inspected. Follow the lighting instructions. Adjust thermostat so unit will operate continuously.
7. Test for spillage at the draft hood/relief opening after 5 minutes of main burner operation. Use the flame of a match or candle, or smoke from a cigarette, cigar or pipe.
8. After making sure that each appliance remaining connected to the common venting system properly vents when tested as above, return doors, windows, exhaust fans, fireplace dampers and other gas burning appliances to their previous conditions of use.
9. Correct any improper operation of the common venting system so that the installation conforms to the latest edition of the National Fuel Gas Code, ANSI Z223.1, in Canada, the latest edition of CAN/CGA-B149 Installation Code for Gas Burning Appliances and Equipment. When resizing any portion of the common venting system, resize to approach the minimum size as determined using the appropriate tables of the latest edition of the National Fuel Gas Code, ANSI Z223.1, in Canada, the latest edition of CAN/CGA-B149 Installation Code for Gas Burning Appliances and Equipment.

### Masonry chimney installation

A masonry chimney must be properly sized for the installation of a high efficiency gas-fired appliance. Venting of a high efficiency appliance into a cold or oversized masonry chimney can result in operational and safety problems. Exterior masonry chimneys, with one or more sides exposed to cold outdoor temperatures, are more likely to have venting problems. The temperature of the flue products from a high efficiency appliance may not be able to sufficiently heat the masonry structure of the chimney to generate proper draft. This will result in condensing of flue products, damage to the masonry flue/tile, insufficient draft and possible spillage of flue products into an occupied living space. Carefully inspect all chimney systems before installation.

#### CAUTION

Venting of high efficiency appliances into a masonry chimney without a sealed stainless steel liner can result in operational and safety problems. Any breaks, leaks, or damage to the masonry flue/tile will allow spillage of the positive pressure flue products from the chimney. These flue products can easily escape into an occupied living space causing a health hazard. If there is any doubt about the condition of a masonry chimney, or its acceptability for use after insertion of a corrosion resistant liner system, consult with local code officials.

### Inspection of a masonry chimney

A masonry chimney must be carefully inspected to determine its suitability for the venting of flue products. A clay-tile-lined chimney must be structurally sound, straight and free of misaligned tile, gaps between liner sections, missing sections of liner or any signs of condensate drainage at the breaching or clean out. If there is any doubt about the condition of a masonry chimney, it must be relined with a properly-sized and approved chimney liner system.

### Vertical vent termination clearances and location

Follow all vertical venting termination information for clearances and location under Vertical Vent Termination Clearances and Location, page 16.

## 2 Venting

Figure 2-7 Other than Direct Vent Terminal Clearances

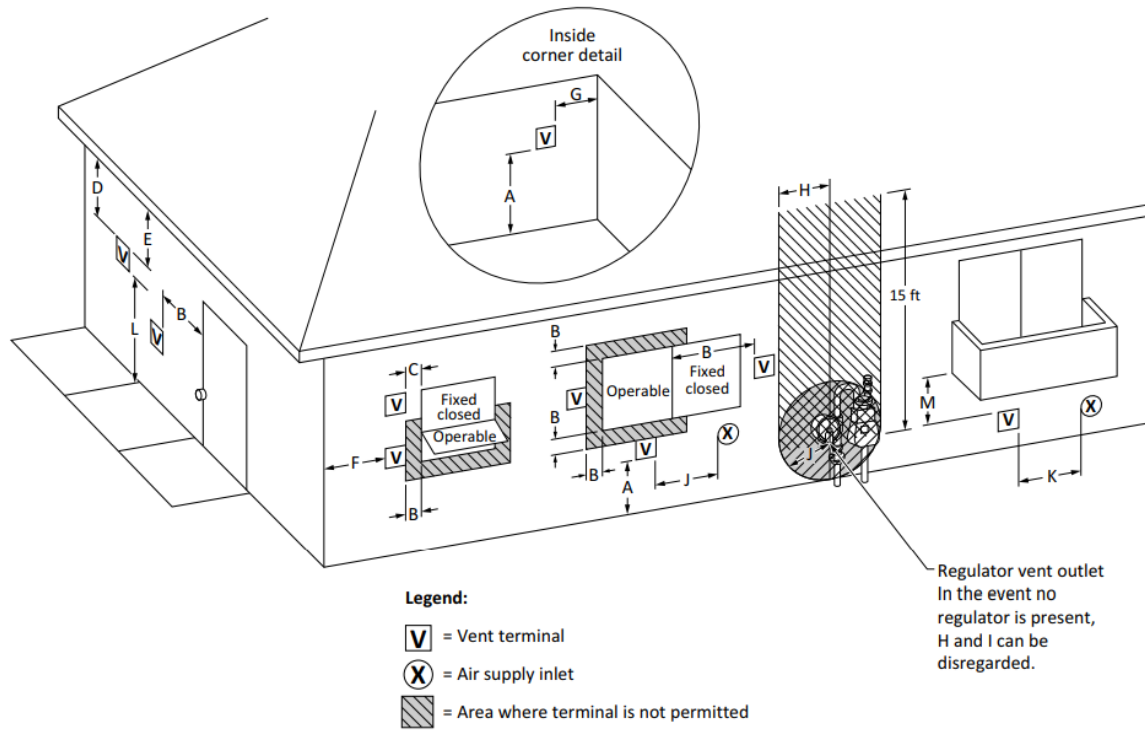


Table 2B Other than Direct Vent Terminal Clearances

		Canadian Installations <sup>1</sup>	US Installations <sup>2</sup>
A =	Clearance above grade, veranda, porch, deck, or balcony	12 in (30 cm)	12 in (30 cm)
B =	Clearance to window or door that may be opened	6 in (15 cm) for appliances ≤ 10,000 Btuh (3 kW), 12 in (30 cm) for appliances > 10,000 Btuh (3 kW) and ≤ 100,000 Btuh (30 kW), 36 in (91 cm) for appliances > 100,000 Btuh (30 kW)	4 ft (1.2 m) below or to side of opening; 1 ft (300 mm) above opening
C =	Clearance to permanently closed window	*	*
D =	Vertical clearance to ventilated soffit located above the terminal within a horizontal distance of 2 ft (61 cm) from the center line of the terminal.	*	*
E =	Clearance to unventilated soffit	*	*
F =	Clearance to outside corner	*	*
G =	Clearance to inside corner	*	*
H =	Clearance to each side of center line extended above meter / regulator assembly	3 ft (91 cm) within a height 15 ft (4.6 m)	*
I =	Clearance to service regulator vent outlet	3 ft (91 cm)	*

## 2 Venting *(continued)*

**Table 2B Other than Direct Vent Terminal Clearances *(continued)***

J =	Clearance to nonmechanical air supply inlet to building or the combustion air inlet to any other appliance	6 in (15 cm) for appliances $\leq$ 10,000 Btuh (3kW), 12 in (30 cm) for appliances > 10,000 Btuh (3 kW) and $\leq$ 100,000 Btuh (30 kW), 36 in (91 cm) for appliances > 100,000 Btuh (30 kW)	4 ft (1.2 m) below or to side of opening; 1 ft (300 mm) above opening
K =	Clearance to a mechanical air supply inlet	6 ft (1.83 m)	3 ft (91 cm) above if within 10 ft (3 m) horizontally
L =	Clearance above paved sidewalk or paved driveway located on public property	7 ft (2.13 m)†	7 ft (2.13 m) for mechanical draft systems (Category I appliances). Vents for Category II and IV appliances cannot be located above public walkways or other areas where condensate or vapor can cause a nuisance or hazard
M =	Clearance under veranda, porch, deck, or balcony	12 in (30 cm)‡	*
<p>* Clearance in accordance with local installation codes and the requirements of the gas supplier.</p> <p>† A vent shall not terminate directly above a sidewalk or paved driveway that is located between two single family dwellings and serves both dwellings.</p> <p>‡ Permitted only if veranda, porch, deck, or balcony is fully open on a minimum of two sides beneath the floor.</p> <p><b>NOTES:</b></p> <p>1) In accordance with the current CSA B149.1, Natural Gas and Propane Installation Code</p> <p>2) In accordance with the current ANSI Z223.1/NFPA 54, National Fuel Gas Code</p>			

## 2 Venting

### 2. Outdoor installation venting

**NOTICE**

Before installing a venting system, follow all venting clearances and requirements found in the Venting, General Information section, page 16.

**⚠ WARNING**

Only install outdoor models outdoors and only use the vent systems supplied by the appliance manufacturer. Personal injury or product damage may result if any other cap is used or if an outdoor model is used indoors. Properly install all covers, doors and jacket panels to ensure proper operation and prevent a hazardous condition.

Units are self-venting and can be used outdoors when installed with the optional outdoor systems. The air inlet cap mounts directly to the unit and covers the combustion air opening. Gasketing is supplied to seal the unit vent pipe to prevent water leakage. The flue requires a 36" vent pipe and cap installed to the heater outlet.

Combustion air supply must be free of contaminants (see Combustion and Ventilation Air, page 12). To prevent recirculation of the flue products into the combustion air inlet, follow all instructions in this section.

#### Outdoor vent/air inlet location

Keep venting areas free of obstructions. Keep area clean and free of combustible and flammable materials. Maintain a minimum clearance of 3" (76mm) to combustible surfaces and 36" clearance to the rear of the unit for outdoor installations. To avoid a blocked air inlet or blocked flue condition, keep the air inlet, flue outlet, and drain slot clear of snow, ice, leaves, debris, etc.

**CAUTION**

Do not install outdoor models directly on the ground. You must install the outdoor unit on a concrete, brick, block, or other non-combustible pad.

**CAUTION**

Do not locate unit so that high winds can deflect off of adjacent walls, buildings or shrubbery causing recirculation. Recirculation of flue products may cause operational problems, bad combustion or damage to controls. Locate unit at least 3 feet (0.91m) from any wall or vertical surface to prevent wind conditions from affecting performance.

**CAUTION**

Do not install in pit or below grade.

**NOTICE**

Multiple outdoor unit installations require 48" (1.22m) clearance between each vent cap. Locate the outdoor cap at least 48" (1.22m) below and 48" (1.22m) horizontally from any window, door, walkway or gravity air intake.

Locate the unit at least 10 feet (3.05m) away from any forced air inlet.

Locate the unit at least 3 feet (0.91m) outside any overhang.

Clearances around outdoor installations can change with time. Do not allow the growth of trees, shrubs or other plants to obstruct the proper operation of the outdoor vent system.

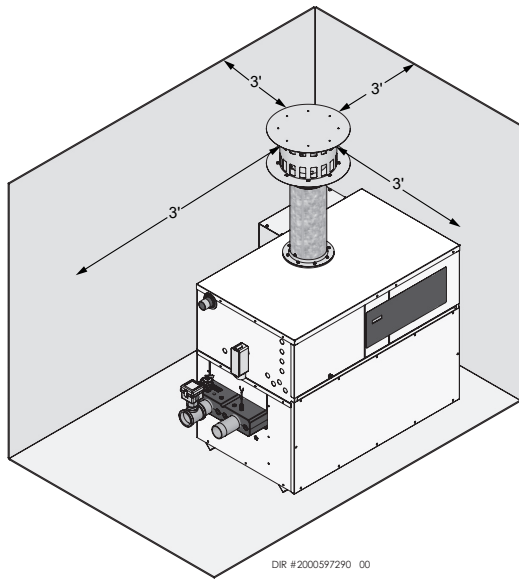
**CAUTION**

A minimum of 3 feet must be maintained at all times from outdoor air vent cap surfaces to combustible construction and/or materials.

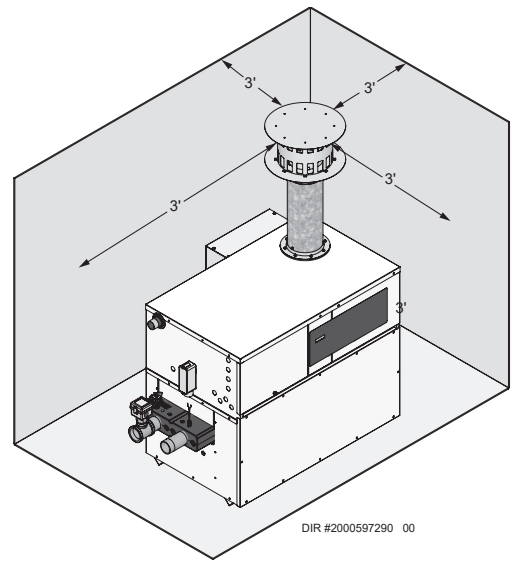
**CAUTION**

Do not install in locations where rain from building runoff drains will spill onto the unit.

## 2 Venting *(continued)*



**Figure 2-8** Outdoor vent kit installed on Models 497 - 747



**Figure 2-9** Outdoor vent kit installed on Models 987 - 2067

### Outdoor vent kit

The optional outdoor vent kit is available from the appliance manufacturer. The outdoor kit part numbers are listed by unit size. See Table 2C for kit numbers. Complete installation instructions are included with the outdoor vent kit. This kit requires a 36" vent pipe and cap (field supplied).

For installation examples see FIG.'s 2-8 and 2-9.

TABLE 2C Outdoor Vent Stack Kits		
Model	Kit* without Pump Cover	Kit* with Pump Cover
497	100337237	100337591
647	100337239	100337592
747	100337239	100337592
987	100337365	100337593
1257	100337366	100337594
1437	100337366	100337594
1797	100337370	100337596
2067	100337370	100337596

\* These kits include an outdoor air cap and flue gasket.

\*\* 36" minimum vent pipe and cap supplied by installer.

## 3 Gas connections

### Connecting to gas supply

Verify that the appliance is supplied with the type of gas specified on the rating plate. This appliance is configured for operation up to 2000 feet altitude. Consult factory for installations above 2000 feet elevation.

**Inlet gas pressure:** Measured at the inlet pressure tap on the appliance gas manifold. The pressure tap is located upstream of the combination gas valve(s).

See Table 3A for maximum and minimum inlet pressures. Do not exceed the maximum. Minimum inlet pressure is for the purpose of input adjustment.

MODEL	NATURAL		LP	
	Max. w.c.	Min. w.c.	Max. w.c.	Min. w.c.
497 - 2067	14"	4.5"	14.0"	8.0"

**Manifold pressure:** The gas regulator on the unit's combination gas valve is adjustable to supply proper manifold pressure for normal operation.

#### NOTICE

If an inline high gas pressure regulator is used, it MUST BE of the lockup type and be located a minimum of 10 feet from the appliance. Failure to do so may result in insufficient gas volume supplied to the appliance.

If you must adjust regulator pressure, follow the instructions under Gas Manifold Pressure Adjustment on page 27. Do not increase regulator pressure beyond specified pressure setting.

### Gas pressure test

1. The appliance must be disconnected from the gas supply piping system during any pressure testing of that system at a test pressure in excess of 1/2 PSIG (3.5 kPa).
2. The appliance must be isolated from the gas supply piping system by closing a manual shutoff valve during any pressure testing of the gas supply piping system at test pressures equal to or less than 1/2 PSIG (3.5 kPa).
3. The appliance and its gas connection must be leak tested before placing it in operation.

### Gas piping

To safely operate this unit, you must properly size the gas supply piping. See Tables 3B through 3D for piping and fitting requirements. Gas pipe size may be larger than heater connection.

The gas connection for Models 497 - 747 is 1 1/4" NPT and on Models 987 - 2067 the gas connection to these units is 2" NPT.

For ease of service, install a union.

Install a manual main gas shutoff valve, outside of the unit gas connection within six feet of the unit in accordance with the requirements of the National Fuel Gas Code, ANSI Z223.1.

You must provide a sediment trap (drip leg) in the inlet of the gas connection to the unit.

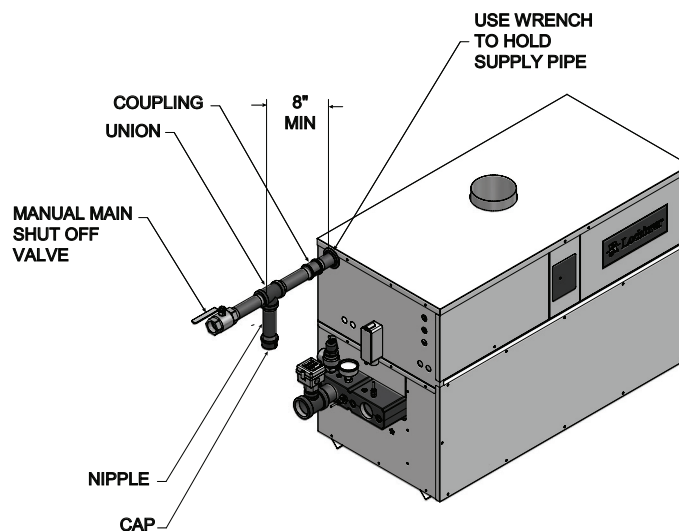
#### NOTICE

It is the installer's responsibility to supply the sediment trap (drip leg).

The combination gas valves have an integral vent limiting device and do not require venting to atmosphere, outside the building. The unit will not operate properly if the reference hose is removed or a vent to atmosphere is installed.

Optional gas controls may require routing of bleeds and vents to the atmosphere, outside the building when required by local codes.

Figure 3-1\_Gas line connection



## 3 Gas connections *(continued)*

### Gas connection

All gas connections must be made with pipe joint compound resistant to the action of liquefied petroleum (L.P.) and natural gases. All piping must comply with local codes and ordinances. Piping installations must comply with approved standards and practices.

1. Make sure gas line is a separate line direct from the meter unless the existing gas line is of sufficient capacity. Verify pipe size with your gas supplier.
2. Use new, properly threaded black iron pipe free from chips. If you use tubing, make sure the ends are cut square, deburred and clean. Make all tubing bends smooth and without deformation. Avoid flexible gas connections. Internal diameter of flexible lines may not provide unit with proper volume of gas.
3. Install a manual main gas shutoff valve at the unit's gas inlet, outside of the unit.
4. Run pipe or tubing to the unit's gas inlet. If you use tubing, obtain a tube to pipe coupling to connect the tubing to the unit's gas inlet.
5. Install a sediment trap in the supply line to the unit's gas inlet (see FIG. 3-1).
6. Apply a moderate amount of good quality pipe compound (do not use Teflon tape) to pipe only, leaving two end threads bare.
7. Remove seal over gas inlet to unit.
8. Connect gas pipe to inlet of unit. Use wrench to support gas manifold on the unit.
9. For L.P. gas, consult your L.P. gas supplier for expert installation.
10. Ensure that all air is completely bled from the gas line before starting the ignition sequence. Start up without properly bleeding air from the gas line may require multiple reset functions of the ignition control module to achieve proper ignition.

#### **WARNING**

Do not have any open flame in proximity to the gas line when bleeding air from the gas line. Gas may be present.

### Gas train and controls

#### **NOTICE**

The gas train and controls assembly provided on this unit have been tested under the applicable American National Standard to meet minimum safety and performance criteria such as safe lighting, combustion and safety shutdown operation.

**TABLE 3B**  
SUGGESTED GAS PIPE SIZE FOR  
SINGLE UNIT INSTALLATIONS

MODEL	Distance from Meter (in feet)				
	0 - 50	51 - 100	101 - 200	201 - 300	301 - 500
497	1 1/4"	1 1/4"	1 1/2"	2"	2"
647	1 1/4"	1 1/2"	2"	2"	2 1/2"
747	1 1/2"	2"	2"	2 1/2"	2 1/2"
987	2"	2"	2 1/2"	2 1/2"	3"
1257	2"	2 1/2"	2 1/2"	3"	3"
1437	2 1/2"	2 1/2"	3"	3"	3 1/2"
1797	2 1/2"	3"	3"	3 1/2"	3 1/2"
2067	2 1/2"	3"	3"	3 1/2"	4"

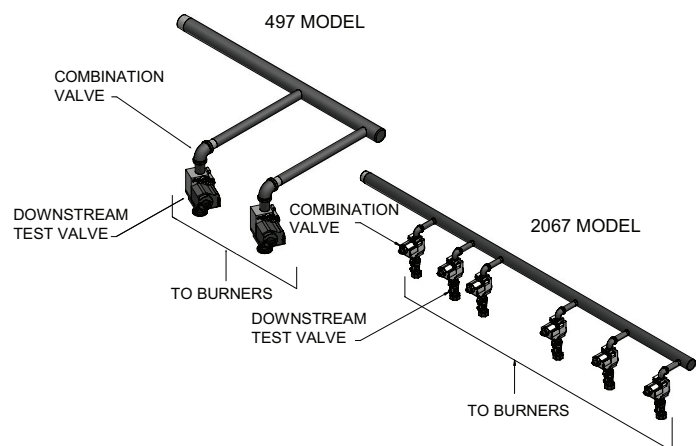
For each elbow or tee, add equivalent straight pipe to total length from Table 3C.

**TABLE 3C**  
FITTINGS TO EQUIVALENT STRAIGHT PIPE

Diameter Pipe (inches)	3/4	1	1 1/4	1 1/2	2	3	4	5
Equivalent length of Straight Pipe (feet)	2	2	3	4	5	10	14	20

Water heater models do not have downstream test valves, but the rest of the gas train is represented by FIG. 3-2.

**Figure 3-2\_Gas train drawing**



## 3 Gas connections

### Combination gas valves

These units fire in multiple stages of burner input. Each stage of burner operation has a combination gas valve(s) to cycle the gas supply on and off and regulate gas to the burners. Each combination valve consists of a gas regulator and two valve seats to meet the requirements for redundant gas valves. The valve has a gas control knob that must remain in the open position at all times when the unit is in service. The gas control valve has pressure taps located on the inlet and discharge sides of the valve. Manifold pressure is adjusted using the regulator located on the valve. A manifold gas pressure tap for each burner stick is located on the discharge side of the valve. The manifold pressure is preset at the factory and adjustment is not usually required. If you must adjust regulator pressure, follow the instructions under Gas Manifold Pressure Adjustment, page 27.

### Venting of combination gas valves

The combination gas valve/regulator used on all units is equipped with an integral vent limiting orifice per ANSI Z21.78. The vent limiter ensures that the volume of gas emitted from the valve in the event of a failed gas diaphragm does not exceed the maximum safe leakage rate allowed by agency requirements.

Combination gas valve/regulators equipped with integral vent limiters are not required to have vent or relief lines piped to the outdoors. The termination of the vent limited opening on the combination gas valve/regulator complies with the safety code requirements of CSD-1, CF-190(a) as shipped from the appliance manufacturer without the installation of additional vent lines.

### Checking gas supply pressure

Use the following procedure to check gas supply pressure.

1. Turn the main power switch to the "OFF" position.
2. Turn gas valve knobs to the "OFF" position.
3. Shut off gas supply at the field-installed manual gas cock in the gas piping to the unit. If fuel supply is L.P. gas, shut off gas supply at the tank.
4. Remove the 1/8" hex plug, located on the "inlet" side of the gas valve (FIG. 3-3). You may also use a tapping on the field-installed main manual gas cock or gas piping. Install a fitting in the inlet pressure tapping suitable to connect to a manometer or magnehelic gauge. Range of scale should be 14" w.c. or greater to check inlet pressure.
5. Turn on gas supply at the manual gas cock, turn on L.P. gas at the tank if required.
6. Turn the power switch to the "ON" position.
7. Turn the gas valve knobs to the "ON" position. Set the electronic temperature control or thermostat to call for heat.
8. Observe the gas supply pressure as all burners are firing. Ensure that inlet pressure is within the specified range. See Connecting To Gas Supply, page 24 for minimum and maximum gas supply pressures.
9. If gas pressure is out of range, contact gas utility, gas supplier, qualified installer or service agency to determine necessary steps to provide proper gas pressure to the control.

**TABLE - 3D**  
**Capacity of Schedule 40 Metallic Pipe in Cubic Feet of Natural Gas Per Hour**  
**(based on .60 specific gravity, 0.30" w.c. pressure drop)**

Pipe Size (Inches)	Length of Pipe in Straight Feet													
	10	20	30	40	50	60	70	80	90	100	125	150	175	200
1/2	131	90	72	62	55	N/A	N/A	N/A	N/A	N/A	N/A	N/A	N/A	N/A
3/4	273	188	151	129	114	104	95	89	83	79	70	63	58	N/A
1	514	353	284	243	215	195	179	167	157	148	131	119	109	102
1 1/4	1,060	726	583	499	442	400	368	343	322	304	269	244	224	209
1 1/2	1,580	1,090	873	747	662	600	552	514	482	455	403	366	336	313
2	3,050	2,090	1,680	1,440	1,280	1,160	1,060	989	928	877	777	704	648	602
2 1/2	4,860	3,340	2,680	2,290	2,030	1,840	1,690	1,580	1,480	1,400	1,240	1,120	1,030	960
3	8,580	5,900	4,740	4,050	3,590	3,260	3,000	2,790	2,610	2,470	2,190	1,980	1,820	1,700
4	17,500	12,000	9,660	8,270	7,330	6,640	6,110	5,680	5,330	5,040	4,460	4,050	3,720	3,460

### 3 Gas connections *(continued)*

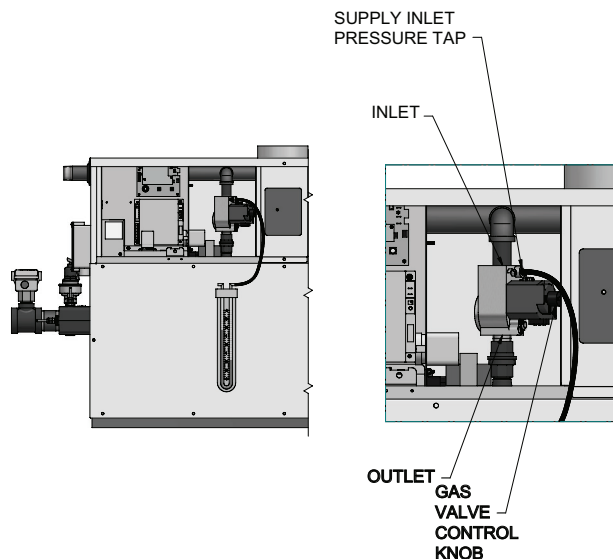
10. If gas supply pressure is within normal range, remove the gas manometer and replace the pressure tap fittings in the gas control as indicated by the following steps.
11. Turn power switch to the “OFF” position.
12. Turn gas valve knob to the “OFF” position.
13. Shut off gas supply at the manual gas cock in the gas piping to the unit. If fuel supply is L.P. gas, shut off gas supply at the tank.
14. Remove the manometer and related fittings from the “inlet side of the gas valve, replace 1/8" hex plug in the gas valve and tighten.
15. Turn on the gas supply at the manual valve, turn on L.P. gas at the tank if required.
16. Turn the power switch to the “ON” position.
17. Turn the gas valve knob to the “ON” position.
18. Set the electronic temperature control or thermostat to call for heat.

#### ⚠ WARNING

After completing any testing on the gas system, leak test all gas connections. Apply a soap/water solution to all gas connections while main burners are operating. Bubbles forming indicate a leak. Repair all leaks at once. Do not operate this unit with a leak in the gas train, valves or related piping.

Check burner performance by cycling the system while you observe burner response. Burners should ignite promptly. Flame pattern should be stable, see Burner Flames in the Maintenance section of this manual. Turn system off and allow burners to cool, then cycle burners again to ensure proper ignition and flame characteristics.

**Figure 3-3** *Measuring gas supply pressure at combination gas valve*



### Gas manifold pressure adjustment

#### NOTICE

The gas valves are referenced to the fan pressurized chamber by a hose connected from the vent of the gas valve regulator to the chamber pressure tap located on the front inside portion of the jacket. Reference the drawings in this section for component and connection points for pressure measurement. The referenced chamber pressure must be subtracted from the manifold pressure to obtain actual net manifold pressure for normal operation.

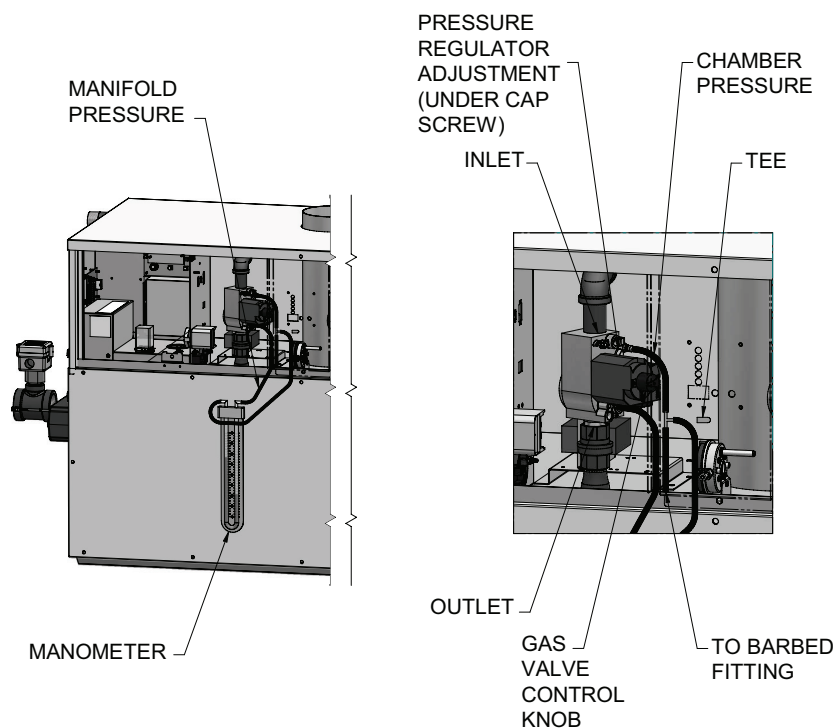
A manometer or magnahelic gauge legible in 0.1" increments up to 10 inches w.c. is required to check and adjust the manifold pressure. The regulator cover screw on the gas valve must be in place and tight for the unit to operate properly.

1. Remove the thumbscrew that fastens the control panel access door and remove the door.
2. Turn the power switch located in the lower left corner behind the control panel access door to the “O” or “OFF” position.
3. Remove the top front jacket access panels to access the gas valve(s).
4. Locate the reference hose on the first gas valve which goes from the vent fitting on the gas valve to the barbed fitting on the deck of the unit (see FIG. 3-4).
5. Remove the flexible cap from the barbed fitting on the “tee” located in this line and hook one side of the manometer, or (-) side of a magnahelic gauge, to this “tee”. Retain this cap for future use.
6. Remove the 1/8" hex plug from the manifold pressure tap on the gas valve (see FIG. 3-4). Retain plug for future use.
7. Install a fitting in this tap that is suitable for connection of a hose to a manometer, or (+) side of a magnahelic gauge (see FIG. 3-4).
8. Turn the power switch to the “I” or “ON” position.
9. Push the reset button(s) for the ignition control(s), if necessary.
10. Set the temperature control to call for heat (see *Setting Temperature Control*, page 41).
11. Once the unit is firing, the manometer/magnahelic will reflect the net manifold gas pressure. Compare this reading to the respective value in Table 3E for Natural Gas or Propane Gas.

### 3 Gas connections

12. If adjustment is necessary, remove the regulator cover screw on the gas valve. Note: If the gas valve under adjustment is located on a manifold assembly monitored by an igniter, the unit may shut down and recycle when the regulator cover screw is removed. This is normal.
13. Turn the regulator adjustment screw “clockwise” to raise the regulator gas pressure. Turn the regulator adjustment screw “counterclockwise” to lower the regulator gas pressure.
14. Replace the regulator cover screw and make sure it is tight for proper operation.
15. Read the value on the manometer/magnahelic and compare it to the values in TABLE- 3E.
16. Repeat this adjustment procedure for each gas valve as necessary to adjust to the proper manifold gas pressure.
17. Remove hoses, replace and tighten plugs and caps when complete.
18. Replace top front upper jacket access panels and control panel door in reverse order.
19. If proper ignition and burner operation is not achieved after checking gas supply pressure, see Cleaning and Maintenance, page 61 for Combustion Air Fan Adjustment. Follow the procedure to adjust the combustion air fans as necessary.

**Figure 3-4\_Measuring manifold gas pressure**



**TABLE 3E**  
**Net Manifold Pressure**  
**Regulator Pressure Less**  
**Front Chamber Pressure**

MODEL	Nat. Gas	LP
497 - 747	1.8" w.c.	--
987 - 2067	1.2" w.c.	--
497-2067	--	4.6" w.c.

## 4 Water connections

### Inlet and outlet connections

For ease of service, install unions on the water inlet and water outlet of the unit. The connection to the unit marked “Inlet” on the header should be used for return from the system. The connection on the header marked “Outlet” is to be connected to the supply side of the system.

Figure 4-1\_Water Connections\_Models 497 - 797

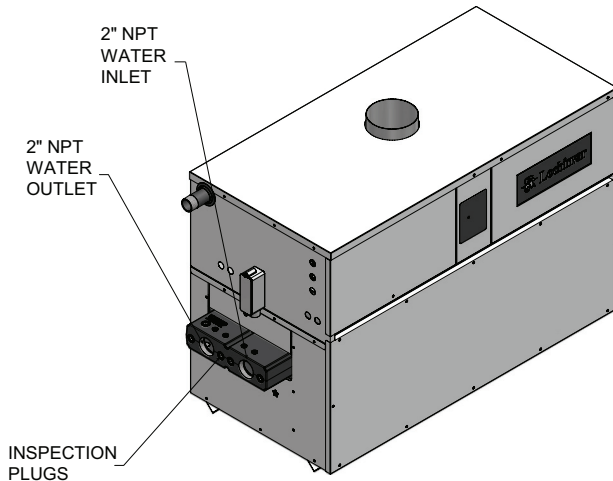
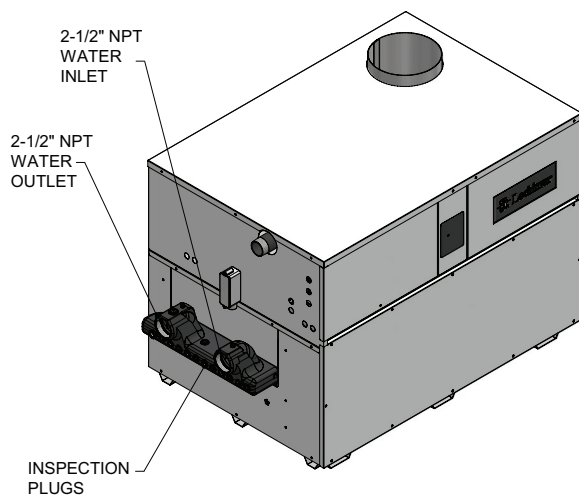


Figure 4-2\_Water Connections\_Models 987 - 2067



### Relief valve

This unit is supplied with a relief valve(s) sized in accordance with ASME Boiler and Pressure Vessel Code, Section IV (“Heating Boilers”). The relief valve(s) is installed in the vertical position and mounted in the hot water outlet. No valve is to be placed between the relief valve and the unit. To prevent water damage, the discharge from the relief valve shall be piped to a suitable floor drain for disposal when relief occurs. No reducing couplings or other restrictions shall be installed in the discharge line. The discharge line shall allow complete drainage of the valve and line. Relief valves should be manually operated at least once a year.



Avoid contact with hot discharge water.

### Water flow switch

A water flow switch is factory installed in the outlet piping on all heating boilers and water heaters. The flow switch must prove water flow before a trial for ignition can begin. The flow switch requires a minimum flow of 15 - 18 GPM on Models 497 - 747 and 26 GPM on Models 987 - 2067 to make the flow switch and start burner operation. A water flow switch meets most code requirements for a low water cutoff device on boilers requiring forced circulation for operation.

### Low water cutoff (if equipped)

If this boiler is installed above radiation level, a low water cutoff device must be installed at the time of boiler installation. An electronic low water cutoff is available as a factory supplied option on all models. The low water cutoff should be inspected every 6 months.

## Heating boiler installations

### Piping of the boiler system

The drawings in this section show typical boiler piping installations, see FIG.'s 4-5 through 4-8. Before beginning the installation, consult local codes for specific plumbing requirements. The installation should provide unions and valves at the inlet and outlet of the boiler so it can be isolated for service. An air separation device must be supplied in the installation piping to eliminate trapped air in the system. Locate a system air vent at the highest point in the system. The system must also have a properly sized expansion tank installed. Typically, an air charged diaphragm-type expansion tank is used. The expansion tank must be installed close to the boiler and on the suction side of the system pump to ensure proper operation. A water meter to monitor makeup water is recommended. Makeup water volume should not exceed 5% of total system per year. Install a Y-strainer or equivalent multi-purpose strainer just before the boiler pump at the inlet of the heat exchanger. This item is used to remove system debris from older hydronic systems and to protect newer systems.



The boiler system should not be operated at less than 12 PSIG(83 kPa) (Non-metallic system piping must have an oxygen barrier to be considered a closed loop).

Hot water piping must be supported by suitable hangers or floor stands, **NOT** by the boiler. Copper pipe systems will be subject to considerable expansion and contraction. Rigid pipe hangers could allow the pipe to slide in the hanger resulting in noise transmitted into the system. Padding is recommended on rigid hangers installed with a copper system. The boiler pressure relief valve must be piped to a suitable floor drain. See the *Relief Valve* section on this page.



A leak in a boiler “system” will cause the “system” to intake fresh water constantly, which will cause the tubes to accumulate a lime/scale build up. This will cause a non-warrantable failure.

## 4 Water connections

### Water connections (heating boilers only)

Inlet and outlet water connections on Models 497 - 747 have 2" NPT and on Models 987 - 2067 the inlet and outlet connections are 2 1/2" NPT.

#### CAUTION

Field installed reducing bushings must not be used to reduce below the pipe diameters of the models listed above.

Any reduction in pipe size may decrease flow resulting in high water temperatures, boiler noise, flashing to steam, and non-warrantable heat exchanger damage.

The boiler may be installed with a primary/secondary piping system provided to the boiler. It is important to guarantee that adequate flow is provided to properly dissipate heat from the boiler and also ensure that flow through the boiler does not exceed the maximum recommended flow rate of 55 GPM for Models 497 - 747 and 90 GPM for Models 987 - 2067 for a boiler equipped with a copper heat exchanger.

### Boiler circulator requirements

This is a low mass, high efficiency hot water boiler which must have adequate flow for quiet, efficient operation. Pump selection is critical to achieve proper operation. A pump should be selected to achieve proper system design water temperature rise. Pipe diameter and length are critical to ensure proper flow through the boiler. A System Temperature Rise Chart (Table 4B on page 32) is provided to assist in proper pump selection. This table provides GPM and boiler head-loss at various temperature rises for each model based on Btu/hr input. Temperature rise is the difference in boiler inlet temperature and boiler outlet temperature while the boiler is firing at full rate.

**Example:** The boiler inlet temperature is 160°F (71.1°C) and the boiler outlet temperature is 180°F (82.2°C). This means that there is a 20°F (11.1°C) temperature rise across the boiler. The boiler temperature rise is visible in the Operator Interface on the boiler's front control panel.

### Circulator pump specifications

1. Maximum operating pressure for the pump must exceed system operating pressure.
2. Maximum water temperature should not exceed the nameplate rating.
3. Cast iron circulators may be used for closed loop systems.
4. A properly sized expansion tank must be installed near the boiler and on the suction side of the pump.

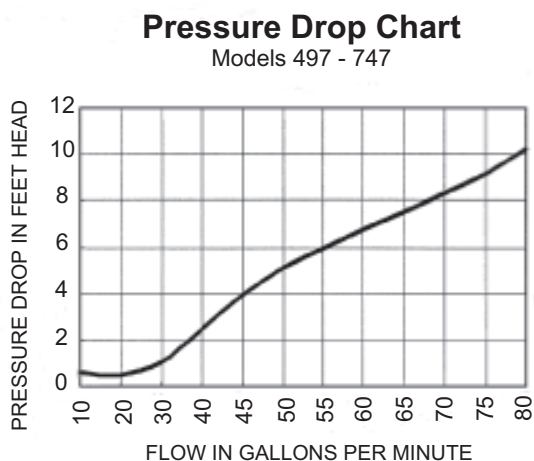
### Circulator pump operation (heating boilers only)

The boiler pump must run when the boiler is firing. Separate supply circuits can be provided or the two circuits (pump and controls) can be combined for connection to one circuit, properly sized for both.

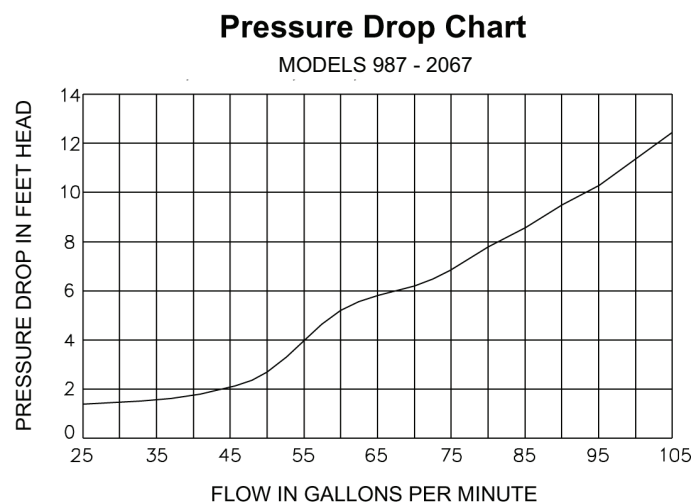
### Pump delay operation

A pump delay operation feature is provided. The boiler's circulating pump will cycle on at each call for heat, before the burner fires. The pump will continue to operate while the burner is firing. The pump will run for a minimum 30 second period after the temperature set point is satisfied. This timing will remove any of the residual heat from the combustion chamber before turning the pump off. See the wiring diagram in Section 10 of this manual.

**Figure 4-3** Heat exchanger pressure drop chart Models 497- 747



**Figure 4-4** Heat exchanger pressure drop chart Models 987 - 2067



## 4 Water connections *(continued)*

**Pump Maintenance:** Inspect the pump every six (6) months and oil as necessary. Use SAE 30 non-detergent oil or lubricant specified by the pump manufacturer.

**The boiler is recommended for installation in a primary/secondary piping system.** This type of system uses a separate boiler circulating pump to supply flow to and from the boiler only. The secondary pump is sized based on the head loss of the boiler and related pipe and fittings in the secondary loop only.

A properly sized primary system pump provides adequate flow to carry the heated boiler water to radiation, air over coils, etc. The fittings that connect the boiler to the primary system should be installed a maximum of 12 inches (0.30m) (or 4 pipe diameters) apart to ensure connection at a point of zero pressure drop in the primary system. There should be a minimum of 10 pipe diameters of straight pipe before and after the boiler secondary loop connections to prevent turbulent flow at the secondary loop connections. The secondary loop piping to and from the boiler must have a fully ported ball valve installed in both the supply and return side piping. The ball valves must be fully ported having the same inside diameter as the installed piping. The ball valve in the piping supplying water to the boiler will only be used as a service valve. The ball valve installed in the discharge from the boiler back to the primary system will be used to adjust boiler flow and temperature rise to ensure proper performance.

The boiler primary piping system must have a circulator installed in the main system loop to carry the heated boiler water to the point of use in the main system.

Multiple boilers may also be installed with a primary/secondary manifold system. Multiple boilers should be connected to the common manifold in reverse return to assist in balancing flow to multiple boilers.

The installer must ensure that the boiler has adequate flow without excessive temperature rise. Low system flow can result in overheating of the boiler water which can cause short burner cycles, system noise, relief valve discharge and in extreme cases, a knocking flash to steam. These conditions indicate the need to increase boiler flow to and from the boiler. This is generally accomplished by either increasing the size of the boiler pump or by increasing the diameter of the piping that connects the boiler to the primary system. A larger diameter pipe reduces head loss and increases flow.

**CAUTION** At no time should the system pressure be less than 12 PSIG.

**CAUTION** Do not allow the flow in the primary loop to drop lower than the flow in the secondary loop at any time during boiler operation. Improper operation of the boiler(s) and possible tripping of the high limits and relief valves may occur.

### Minimum boiler water temperatures

Inlet water temperatures below the specified minimum of 140°F (60°C) can excessively cool the products of combustion resulting in condensation on the heat exchanger. Condensation on the heat exchanger can cause operational problems, bad combustion, sooting, flue gas spillage and reduced service life of the related components. See the Low Temperature Bypass Requirements section for boiler system applications below the minimum specified temperature.

### Low system water volume

System run time is very important to the overall operating efficiency of the boiler. Short cycling of the boiler creates problems with condensation in the vent stack, condensation on the heat exchanger, system temperature spikes, and mechanical component failures. To prevent short cycling of the boiler, it is important to limit the boiler cycles to six or fewer per hour.

A buffer tank is an effective way to enhance a small system load and increase heating system efficiency (see FIG. 4-8 on page 36 of this manual). Buffer tanks add water volume to the system and act as a flywheel to absorb the additional Btu's provided by the boiler when only a single zone of a large system is calling for heat.

To calculate the proper buffer tank size for a multiple zone system:

$$\frac{(\text{Run Cycle})(\text{Output} - \text{Minimum System Load})}{(\text{Temp. Rise})(8.33)(60 \text{ Min.})}$$

CFN2067

Min. Load = 100,000 Btu/Hr

Min. Boiler Output = 850,000 Btu/Hr

Cycle Time = 10 Min

Temp. Rise = 38

$(10)(850,000 - 100,000) / (38)(8.33)(60) = 395 \text{ Gallons}$

## 4 Water connections

### Low temperature return water systems

Any non-condensing boiler and venting system will develop operational problems when exposed to inlet water temperatures below 140°F. Lochinvar offers a low temperature protection valve (LTV) that is factory preset to maintain 140°F inlet water to the boiler regardless of the system return water temperature. See Table 4A for available valve kits.

MODEL	LTV VALVE KIT
497 - 747	100172001
987 - 2067	100172000

Be sure to install the LTV valve per the piping diagrams included with the kits. Alternatively, a bypass as shown in FIG. 4-6 may be piped into the system. This piping is like a primary/secondary boiler installation with a bypass in the secondary boiler piping. Inlet water temperatures below 140°F (60°C) can excessively cool the products of combustion resulting in condensation on the heat exchanger and in the flue.

Condensation can cause operational problems, bad combustion, sooting, flue gas spillage and reduced service life of the vent system and related components. The bypass allows part of the boiler discharge water to be mixed with the cooler boiler return water to increase the boiler inlet temperature above 140°F (60°C). This should prevent the products of combustion from condensing in most installations. The bypass should be fully sized with a balancing valve to allow for proper adjustment. A valve must also be provided on the boiler discharge, after the bypass. Closing this discharge valve forces water through the bypass.

Start boiler adjustment with the bypass valve in the full open position and the boiler discharge valve half open. A small amount of the higher temperature boiler discharge water is mixed with the system water to maintain the desired lower system temperature. A remote low temperature range operator is recommended to control the boiler operation based on the lower system temperature. (See *Terminal Strip Connection Options* starting on page 40).

### Radiant floor and snow melt heating systems

This type of heating boiler application operates in a low temperature range which requires a boiler bypass as described under the Low Temperature Bypass Requirements section. A non-metallic rubber or plastic tubing installed in a radiant (in floor) system must have an oxygen barrier to prevent oxygen from entering the system through the walls of the installed tubing. Excessive oxygen absorption into the system will result in an accelerated rate of corrosion causing a sludge buildup. This excessive corrosion will also damage the boiler and system components. Sludge formed as the result of excessive oxygen in the system can restrict water flow resulting in a premature boiler failure. Any boiler damage due to excessive oxygenation is non-warrantable.

Btu/hr		10°F ΔT		20°F ΔT		30°F ΔT		40°F ΔT		50°F ΔT		60°F ΔT	
Input	Output	GPM	Ft/hd	GPM	Ft/hd	GPM	Ft/hd	GPM	Ft/hd	GPM	Ft/hd	GPM	Ft/hd
495,000	416,000	80+	*	40	4.0	27	1.6	20	0.6	16	0.6	13	0.6
645,000	542,000	129+	*	52	5.1	35	3.0	26	1.2	21	0.8	17	0.6
745,000	626,000	149+	*	60	*	40	4.0	30	1.6	24	1.2	20	0.7
985,000	827,000	197+	*	80	5.2	53	2.4	40	1.4	32	1.0	27	0.8
1,255,000	1,054,000	251+	*	102+	*	68	4.3	51	2.3	41	1.6	34	1.1
1,435,000	1,205,000	288+	*	116+	*	78	6.0	58	3.7	47	2.2	39	1.7
1,795,000	1,508,000	360+	*	146+	*	97+	*	73	6.2	58	4.2	49	2.4
2,065,000	1,735,000	414+	*	168+	*	112+	*	84	8.7	67	6.0	56	4.5

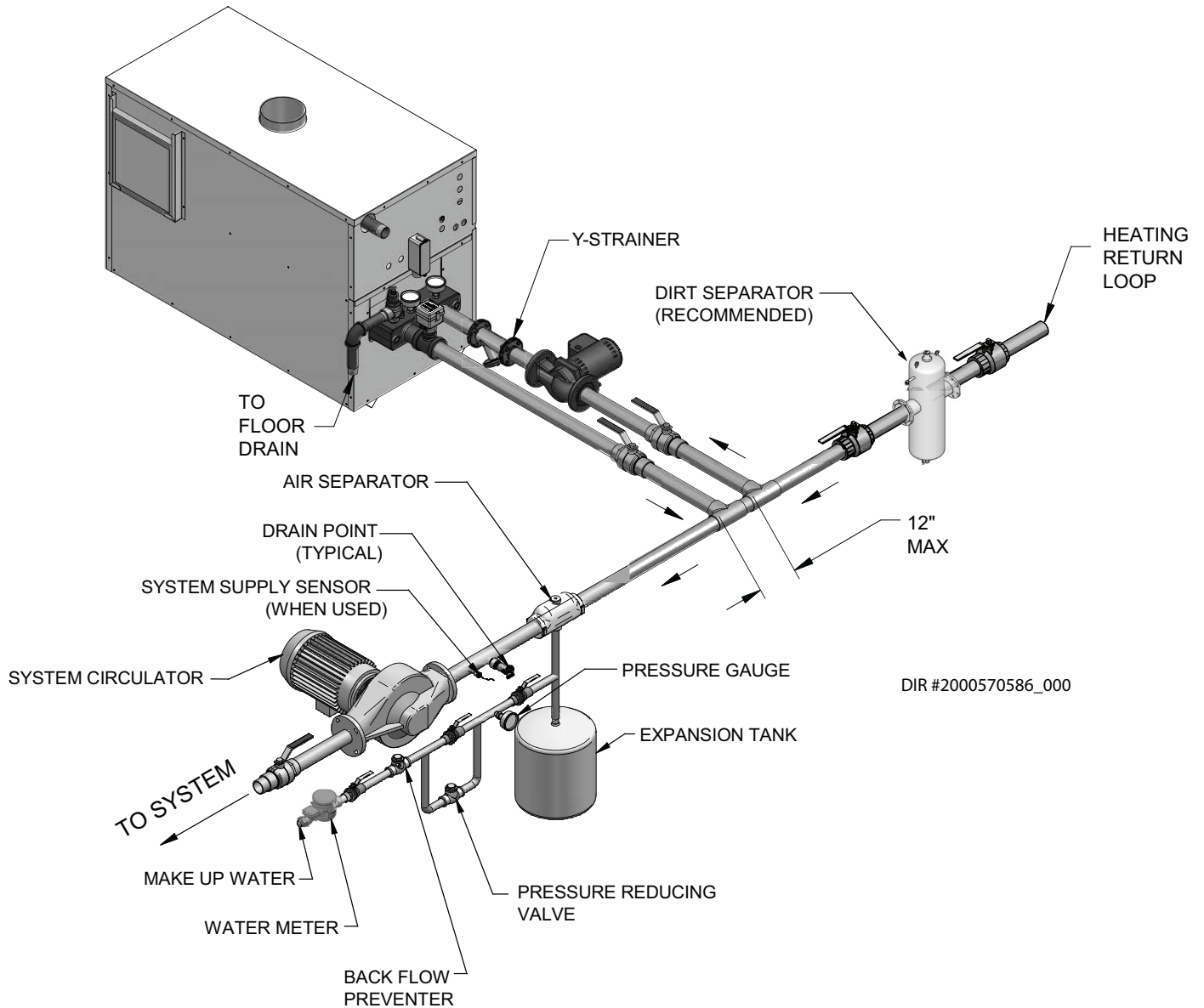
+ These flow rates exceed recommended flow rates of boiler. If these system temperature rises are used, an external piping bypass must be installed.  
\*These foot head calculations exceed the maximum allowable flow rate of the boiler. Requires Cupro-Nickel heat exchanger.

# 4 Water connections *(continued)*

Figure 4-5 Primary/secondary piping of single boiler

COMMON MANIFOLD SIZE (Min.) Models: 497 - 747		
Number of Units	GPM	Diameter (in.)
1	60	2

COMMON MANIFOLD SIZE (Min.) Models: 987 - 2067		
Number of Units	GPM	Diameter (in.)
1	90	2 1/2



DIR #2000570586\_000

**NOTICE**

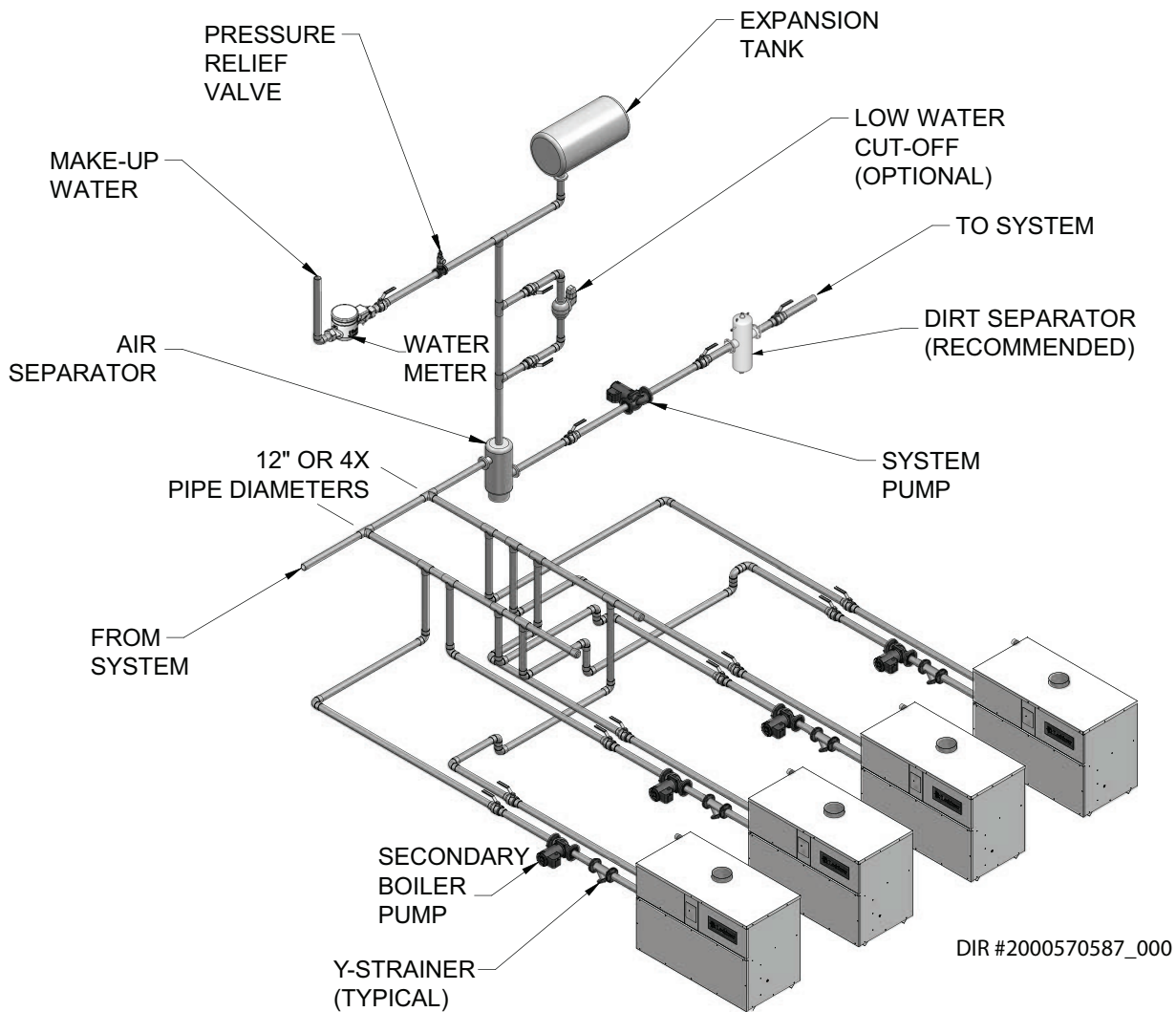
\*Please note that these illustrations are meant to show system piping concept only, the installer is responsible for all equipment and detailing required by local codes.

## 4 Water connections

Figure 4-6 Primary/secondary piping of multiple boilers

COMMON MANIFOLD SIZE (Min.) Models: 497 - 747		
Number of Units	GPM	Diameter (in.)
2	120	3
3	180	3 1/2
4	240	4
5	300	5
6	360	5
7	420	6
8	480	6

COMMON MANIFOLD SIZE (Min.) Models: 987 - 2067		
Number of Units	GPM	Diameter (in.)
2	180	4
3	270	5
4	360	6
5	450	6
6	540	6
7	630	8
8	720	8



### NOTICE

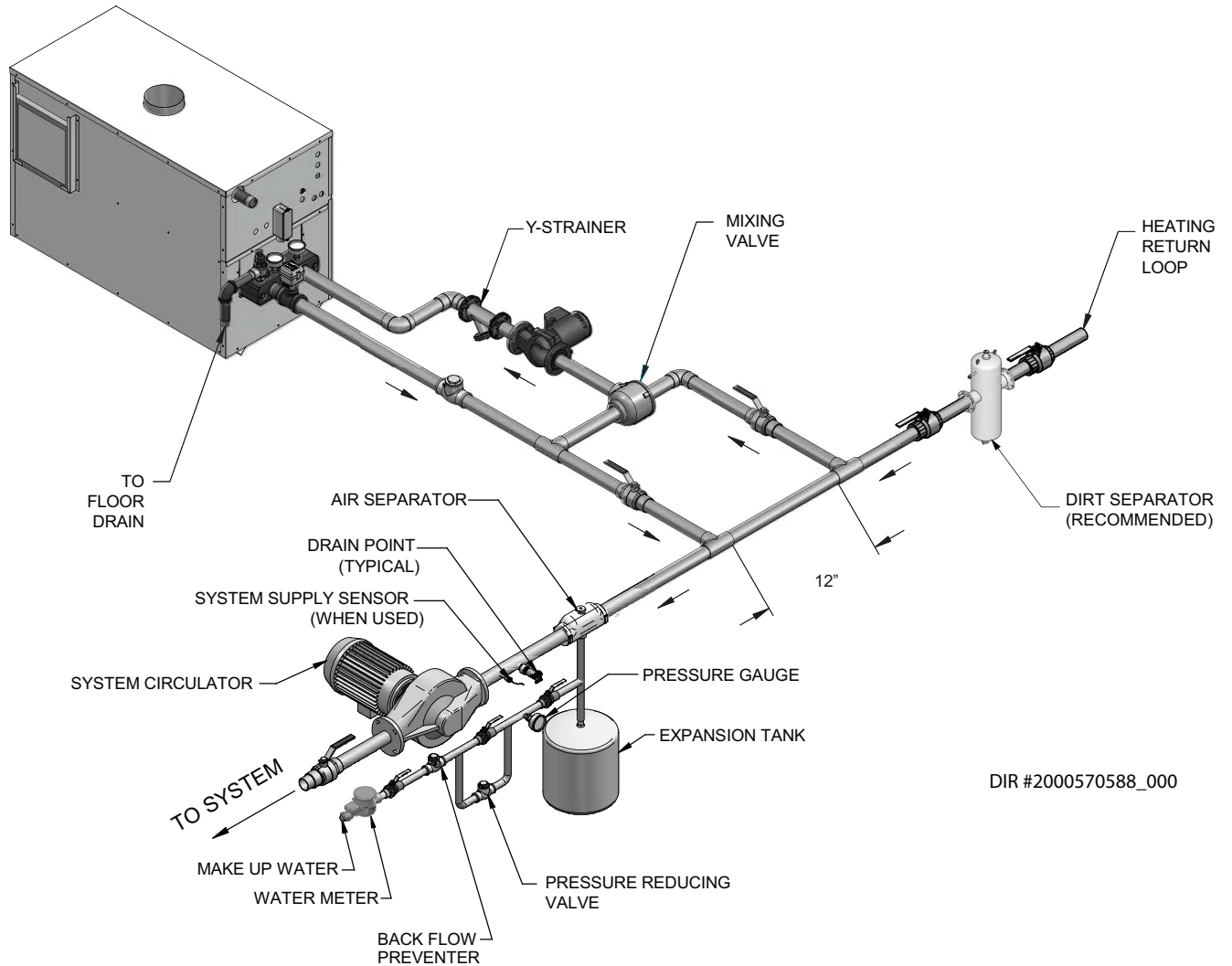
\*Please note that these illustrations are meant to show system piping concept only, the installer is responsible for all equipment and detailing required by local codes.

# 4 Water connections *(continued)*

Figure 4-7\_Boiler with low temperature bypass

COMMON MANIFOLD SIZE (Min.) Models: 497 - 747		
Number of Units	GPM	Diameter (in.)
1	60	2

COMMON MANIFOLD SIZE (Min.) Models: 987 - 2067		
Number of Units	GPM	Diameter (in.)
1	90	2 1/2



DIR #2000570588\_000

**NOTICE**

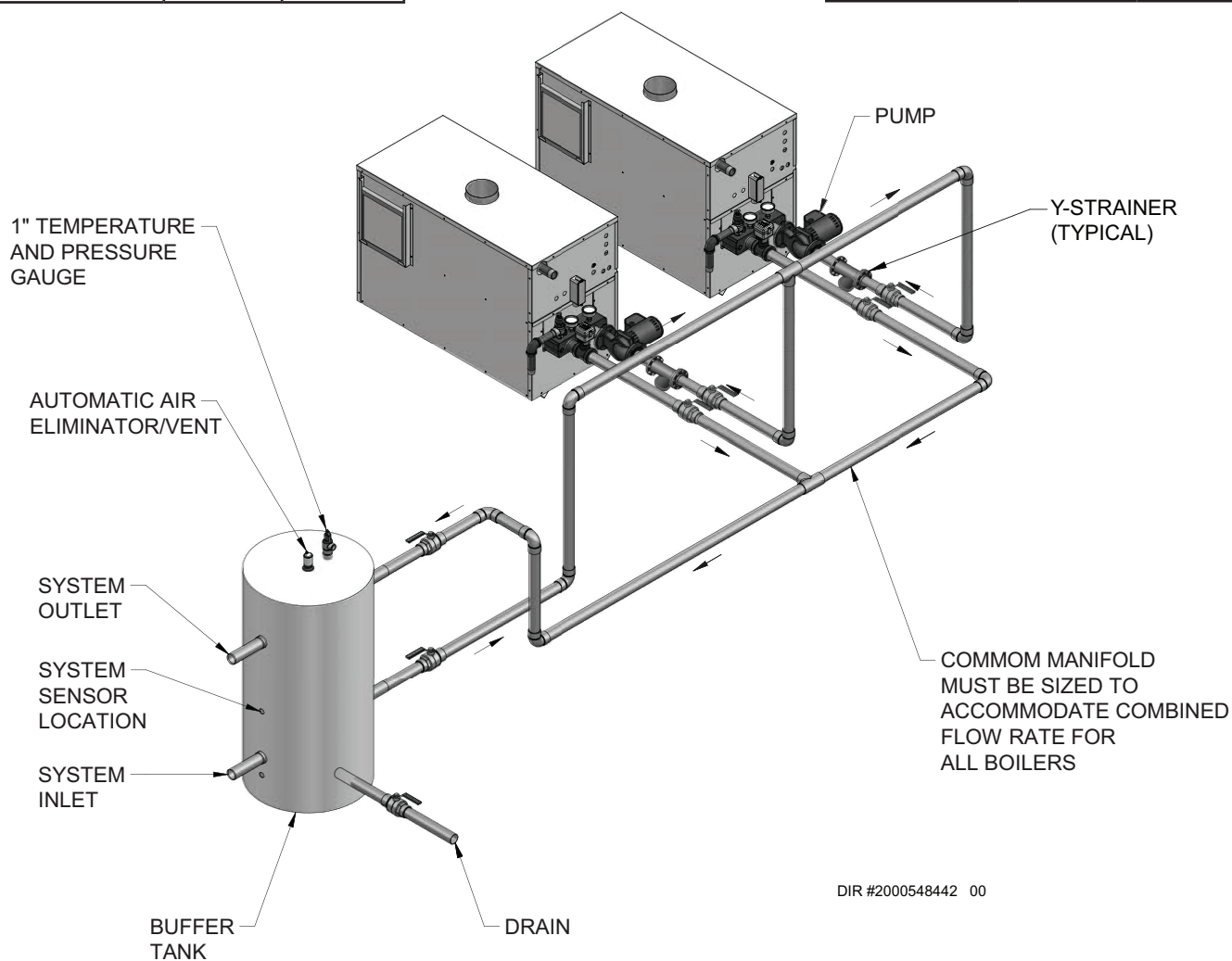
\*Please note that these illustrations are meant to show system piping concept only, the installer is responsible for all equipment and detailing required by local codes.

## 4 Water connections

Figure 4-8 Primary/secondary piping with buffer tank

COMMON MANIFOLD SIZE (Min.) Models: 497 - 747		
Number of Units	GPM	Diameter (in.)
2	120	3
3	180	3 1/2
4	240	4
5	300	5
6	360	5
7	420	6
8	480	6

COMMON MANIFOLD SIZE (Min.) Models: 987 - 2067		
Number of Units	GPM	Diameter (in.)
2	180	4
3	270	5
4	360	6
5	450	6
6	540	6
7	630	8
8	720	8



DIR #2000548442 00

### NOTICE

\*Please note that these illustrations are meant to show system piping concept only, the installer is responsible for all equipment and detailing required by local codes.

## 4 Water connections *(continued)*

### Installation with a chilled water system

Pipe refrigeration systems in parallel. Install duct coil downstream at cooling coil. Where the hot water heating boiler is connected to a heating coil located in the air handling units which may be exposed to refrigeration air circulation, the boiler piping system must be equipped with flow control valves or other automatic means to prevent gravity circulation of the boiler water during the cooling cycle.

The coil must be vented at the high point and hot water from the boiler must enter the coil at this point. Due to the fast heating capacity of the boiler, it is not necessary to provide a ductstat to delay circulator operation. Also, omit thermostat flow checks as the boiler is cold when heating thermostat is satisfied. This provides greater economy over maintaining standby heat.

### Typical heating boiler installations

#### General plumbing rules:

1. Check all local codes.
2. For serviceability of boiler, always install unions.
3. Always pipe pressure relief valve to an open drain.
4. Locate system air vents at highest point of system.
5. Expansion tank must be installed near the boiler and on the suction side of the system pump.
6. Support all water piping.

Model	Temperature Rise °F
497	15 @ 55 GPM
647	20 @ 55 GPM
747	23 @ 55 GPM
987	19 @ 90 GPM
1257	24 @ 90 GPM
1437	27 @ 90 GPM
1797	34 @ 90 GPM
2067	39 @ 90 GPM

### Boiler flow rate

#### ⚠ CAUTION

Do not exceed the maximum flow rate of the heating boiler.

Model	Maximum Flow	Maximum Flow for CuNi Heat Exchanger
497, 647, and 747	55 GPM	75 GPM
987, 1257, 1437, 1797, and 2067	90 GPM	115 GPM

⚠ CAUTION: The maximum flow rate through a water heater with a copper heat exchanger must be set to provide and not exceed the following flow:

The heat exchanger is generally capable of operating within the design flow rates of the building heating system. Should the flow rate exceed the maximum allowable flow rate through the boiler an external bypass must be installed. The bypass should be fully sized with a balancing valve to allow for proper adjustment of flow. Flow rate can be determined by measuring the temperature rise through the boiler.

## 4 Water connections

### Boiler bypass requirements

The installer must ensure that the boiler is supplied with adequate flow without excessive temperature rise. It is recommended that this boiler be installed with a bypass in the piping if the maximum recommended flow rate is exceeded. The bypass will help to ensure that the boiler can be supplied with adequate water flow. Flow rates exceeding the maximum recommended flow will result in erosion of the boiler tubes. A typical bypass with a valve as shown in FIG. 4-6 will allow control of boiler flow.

### Temperature / pressure gauge

This boiler is equipped with a dial type temperature / pressure gauge. This gauge is factory installed in the outlet side of the boiler piping. The gauge has one scale to read system pressure and a separate scale to read water temperature in degrees Fahrenheit. The temperature / pressure gauge is provided to meet code requirements. Water temperatures can be more accurately monitored from the data provided in the digital display in the Operator Interface.

### Filling the system

All air must be purged from the system for proper operation. An air scoop and air vent must be located close to the boiler outlet and there should be a minimum distance between the cold water feed and the system purge valve.

1. Close all drain cocks and air vents.
2. Open the makeup water valve and slowly fill the system.
3. If a makeup water pump is employed, adjust the pressure to provide a minimum of 12 psi at the highest point in the system. If a pressure regulator is also installed in the line, it should be adjusted to the same pressure.
4. Close all valves. Purge one circuit at a time as follows:
  - A. Open one circuit drain valve and let the water drain for at least five minutes. Ensure that there are no air bubbles visible in the water stream before closing the drain valve.
  - B. Repeat this procedure for each circuit.
5. Open all valves after all circuits have been purged. Make sure there are no system leaks.

### ⚠ CAUTION

Do not use petroleum based stop leak products. All system leaks must be repaired. The constant addition of make-up water can cause damage to the boiler heat exchanger due to scale accumulation. Scale reduces flow and heat transfer, causing overheating of the heat exchanger.

6. Run the system circulating pump for a minimum of 30 minutes with the boiler turned off.
7. Open all strainers in the system and check for debris.
8. Recheck all air vents as described in step 4.
9. Inspect the liquid level in the expansion tank. The system must be full and under normal operating pressure to ensure proper water level in the expansion tank. Ensure that diaphragm type expansion tanks are properly charged and not water logged.
10. Start the boiler according to the operating instructions in this manual. Operate the system, including the pump, boiler and radiation units, for one hour.
11. Recheck the water level in the expansion tank. If it exceeds half the tank volume, open the tank to reduce the water level. Recheck pressure charge on diaphragm type tanks.
12. Shut down the entire system and vent all radiation units and high points in the system.
13. Close the water makeup valve and check the strainer and pressure reducing valve for sediment or debris. Reopen the water makeup valve.
14. Verify system pressure with the boiler pressure gauge before beginning regular operation.
15. Within three days of startup, recheck and bleed all air vents and the expansion tank using these instructions.

### Water treatment

In hard water areas, water treatment should be used to reduce the introduction of minerals to the system. Minerals in the water can collect in the heat exchanger tubes and cause noise on operation. Excessive build up of minerals in the heat exchanger can cause a non-warrantable failure.

## 5 Electrical connections

### Connecting to electrical supply

This unit is wired for 120 VAC service. The unit, when installed, must be electrically grounded in accordance with the requirements of the authority having jurisdiction or in the absence of such requirements, with the latest edition of the National Electrical Code ANSI/NFPA No. 70. When the unit is installed in Canada, it must conform to the CAE C22.1, Canadian Electrical Code, Part 1 and/or local Electrical Codes.

1. Use only Type-T wire [63°F (35°C) rise] on all wiring between the unit and field-installed devices.
2. Enclose line voltage wire exterior to the unit in approved conduit or approved metal-clad cable.
3. The pump must run continuously when the unit is being fired (water heaters must use the pump delay if the pump is to be cycled. See Freeze Protection, page 11 when cycling the pump). Water heaters use the pump delay as standard in accordance with ASHRAE 90.1 requirements.
4. To avoid serious damage, do not energize the unit until the system is filled with water.
5. Provide the unit with proper overload protection.

#### NOTICE

Do not block access to the electrical cover plate when installing electrical conduit.

#### ⚠ WARNING

ELECTRICAL SHOCK HAZARD – For your safety, turn off electrical power supply before making any electrical connections to avoid possible electric shock hazard. Failure to do so can cause severe personal injury or death.

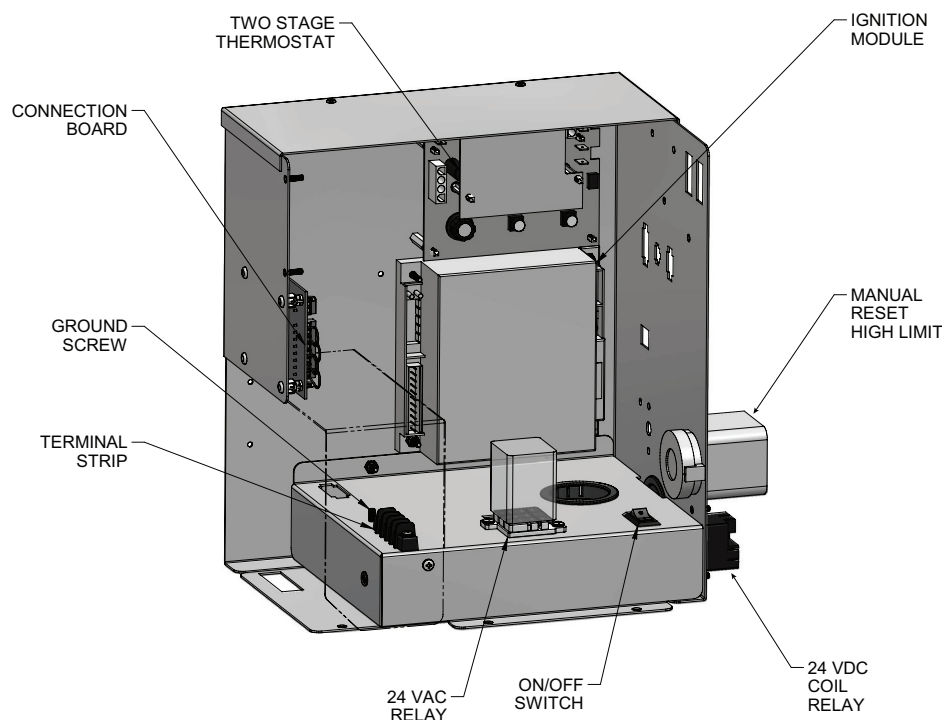
#### ⚠ CAUTION

Label all wires prior to disconnection when servicing controls. Wiring errors can cause improper and dangerous operation.

**TABLE 5A**  
**AMP DRAW DATA**

Model	Controls	Fan	Approximate Total Amps @ 120 VAC
497	4.6	3.4	8.0
647	4.6	3.4	8.0
747	4.6	3.4	8.0
987	4.6	3.4	8.0
1257	4.6	3.4	8.0
1437	4.6	3.8	8.4
1797	4.6	3.8	8.4
2067	4.6	3.8	8.4

**Figure 5-1** Control panel location



## 5 Electrical connections

### Line voltage connections

1. Connect 120 VAC power wiring to the line voltage terminal strip in the junction box, as shown in FIG. 5-2.
2. Provide and install a fused disconnect or service switch (15 AMP recommended) as required by the code (see FIG. 5-2).
3. To activate a system pump, wire as shown in FIG. 5-2. If the motor is larger than 1 HP, you must install a contactor.

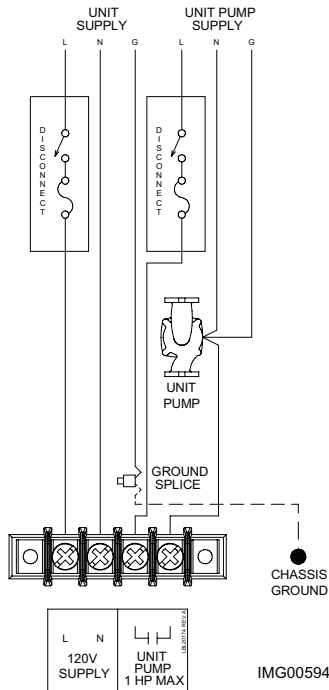


Figure 5-2\_Line Voltage Field Wiring Connections

### External EMS connection to terminal strip for stage firing control of burners

This unit is equipped with a factory installed terminal strip for connection of an energy management system (EMS) to the burner stages. The EMS terminal strip is located in the unit's control panel. Ensure that all wiring used for connection to this terminal strip is properly sized per the recommendations in TABLE 5A. When connecting an EMS to this terminal strip to sequence on each stage of burner operation, the unit's internal thermostat or electronic sequencer should be set as an additional high limit control. This will prevent problems between the set points of the EMS and the boiler's internal controller.

### Terminal strip connection options

Figures 5-3 and 5-4 show the position of jumpers as shipped from the factory for stand-alone operation of boilers or water heaters.

Figures 5-5 and 5-6 show connections to the terminal strip for Remote ON/OFF control of the boiler or water heater. The 1C-1NO jumper must be removed when making these

wiring connections. This remote ON/OFF control will provide an Enable/Disable signal to the unit and allow the unit to operate based on the stage set points, until the remote ON/OFF signal is cancelled.

Figure 5-7 shows the connections necessary to operate the unit as a two-stage (High/Low Fire) boiler or water heater from an Energy Management System (EMS). The actual set point temperatures are controlled by the EMS. The High Fire Offset on the electronic temperature control in the unit must be set to zero and the set point must be set to a value which will function as an upper limit for proper operation under this two-stage control from an EMS.

Figure 5-8 shows the Continuous and Intermittent terminals. External safety devices connected to these terminals will function to protect the unit. Devices connected to the Intermittent terminals (B1 and B2) are monitored only when there is an active Call for Heat. Devices connected to the Continuous terminals (A1 and A2) are monitored continuously and will activate an alarm (if the unit is equipped with the alarm option) anytime the safety device senses an abnormal condition.

Figure 5-3\_Stand-alone operation boiler

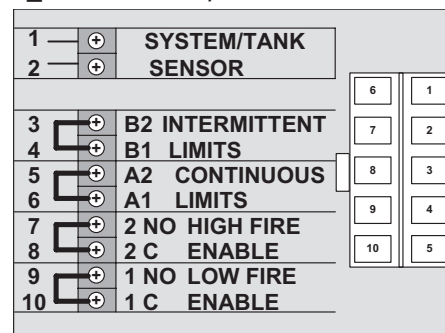


Figure 5-4\_Stand-alone operation water heater

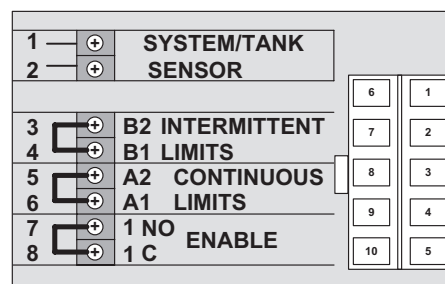
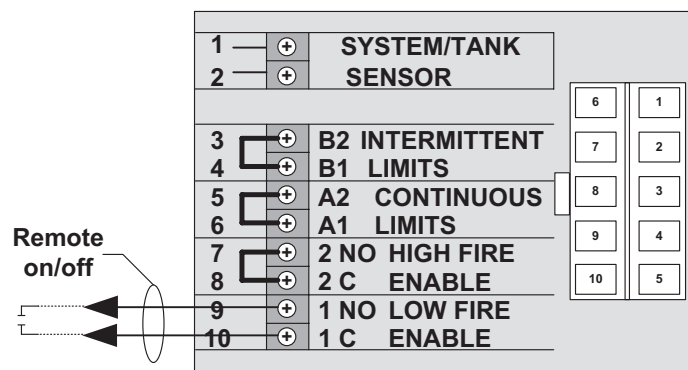


Figure 5-5\_Remote on/off boiler



# 5 Electrical connections *(continued)*

Figure 5-6 Remote on/off water heater

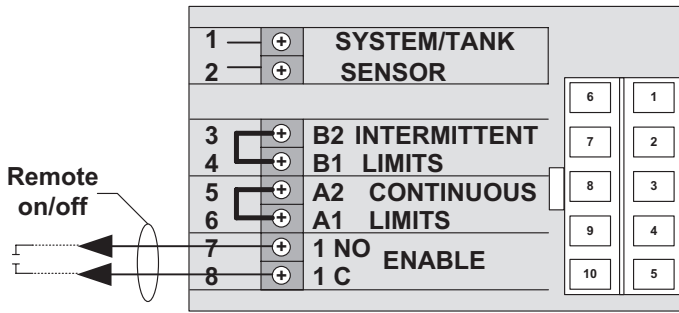


Figure 5-7 Two-stage (high/low fire) boiler

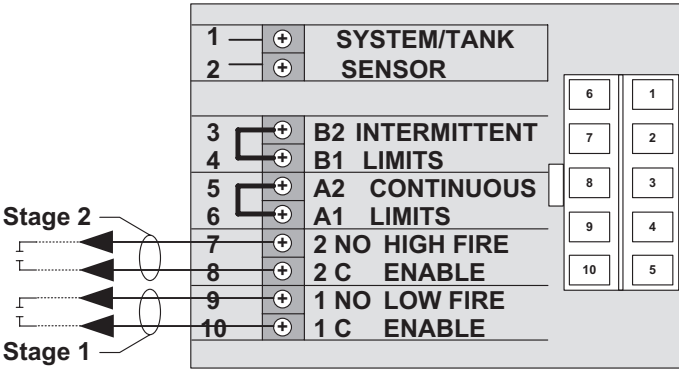
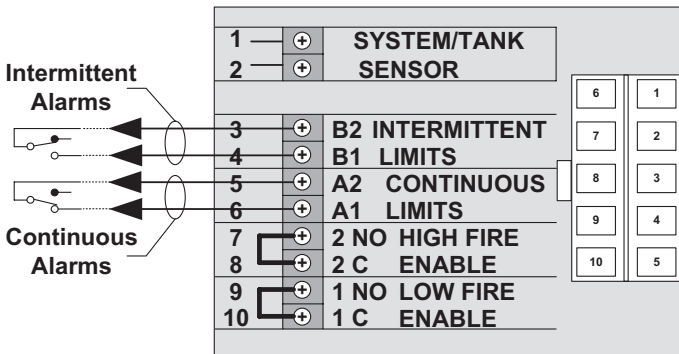


Figure 5-8 Field installation safety devices



## Temperature adjustment

**Note:** The temperature controller is preset at the factory with test settings. You may need to adjust the settings to meet your specific needs.

**WARNING** Return water temperatures must not be less than 140°F. If lower return water temperatures are required, follow the instructions for Low Temperature Return Water Systems on page 32.

## Locating the temperature control

The temperature control is located behind the panel on the left front of the unit (see FIG. 5-9). Follow the steps below to access the temperature control.

1. Loosen the knurled knob at the bottom of the control panel cover.
2. Pull the bottom of the panel out and down to remove.

## Temperature control settings

There are three setting knobs on the temperature control unless your unit is specified as a boiler only with an outdoor air reset option. If your unit is a boiler only with an outdoor air reset option, there are additional controls for this option. They are explained under Outdoor Air Reset Option, page 42.

The three setting knobs on the temperature control are for Set Point, Differential, and High-Fire Offset (see FIG. 5-10).

### Maximum set point

The maximum set point for the control is factory set. Boilers are set to 230°F max., water heaters are set to 190°F max., and specialty state and local codes to 200°F.

These maximum set points are established by not cutting/cutting the OJ1 and OJ2 jumpers located on the right side of the temperature controller (see FIG. 5-10). The maximum set point is determined as shown in Table 5B.

Figure 5-9 Locating temperature control

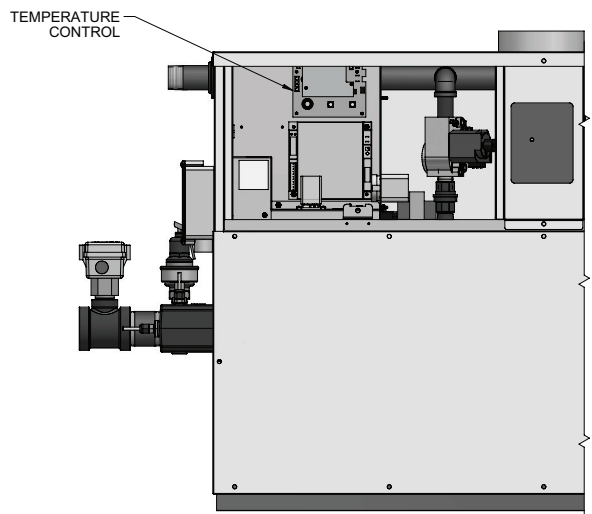
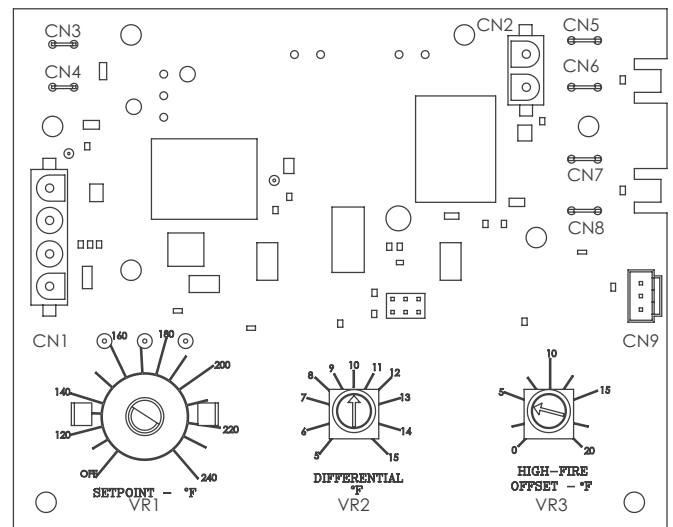


Figure 5-10 Temperature control setting knobs



## 5 Electrical connections

**TABLE 5B**  
Maximum Setpoint Determination

OJ1	OJ2	Max. Setpoint
Connected	Connected	230°
Cut	Connected	190°
Connected	Cut	200°
Cut	Cut	160°

### NOTICE

Anytime that OJ1 is the only jumper cut, a new overlay is required under the Set Point knob on the temperature controller because the scale has changed to a maximum of 190°F.

Anytime the OJ2 jumper is cut (with or without OJ1), a new overlay is required under the Set Point knob on the temperature controller because the scale has changed to a maximum of 200°F.

### Setpoint

The Set Point knob specifies the target water temperature in degrees, Fahrenheit. After the water temperature reaches the set point, the temperature control shuts off the burners.

### Differential

The Differential specifies the number of degrees below the set point that the control will allow the water temperature to drop before it brings the unit back on again.

### High-fire offset

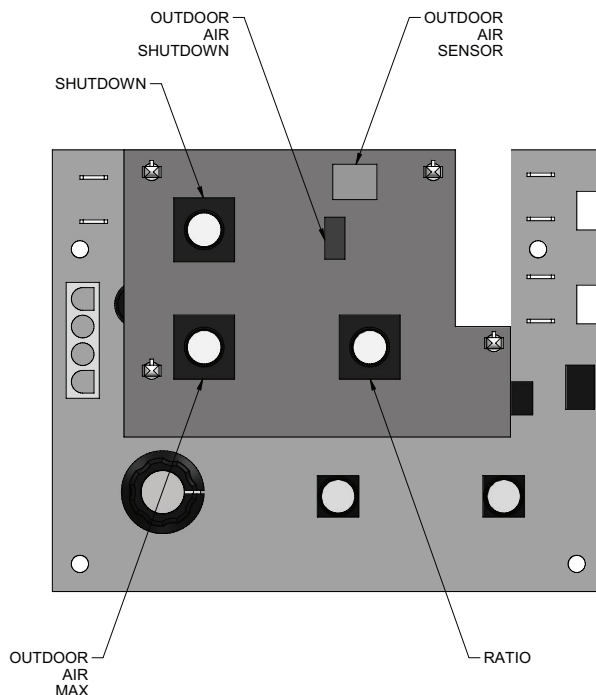
The temperature control operates a two-stage firing system. The two stages are High-Fire and Low-Fire. High-Fire operates all burners while Low-Fire operates approximately one-half of the burners.

The High-Fire knob specifies the number of degrees below set point that the High-Fire stage shuts down. At that point, the unit will continue to operate at the Low-Fire stage until the set point is reached.

The High-Fire offset knob has settings between 0°F and 20°F. If set at 0°F, the High-Fire offset is disabled and the unit will operate at the High-Fire stage until the set point is reached and the temperature control shuts the unit off.

When the High-Fire offset knob is set to 0 or 1, the unit will light at Low Fire and operate for approximately 10 seconds before the High-Fire stage actuates. When set to 2 or above, the unit will operate at Low Fire for approximately 2 minutes before the High Fire stage can actuate.

**Figure 5-11**\_Optional outdoor reset control



### Outdoor reset option

For boilers ordered with the Outdoor Air Reset option, there is an additional control (see FIG. 5-11). There are three setting knobs for Shutdown, Outdoor Air Max., and Ratio. There is also a switch to turn the outdoor air sensor On or Off. An O.A. Sensor is also included.

#### Shutdown

The Shutdown knob specifies the outdoor air shutdown temperature at which the control would prevent the unit from operating. This feature can be enabled/disabled with the O.A. Shutdown switch.

#### Outdoor air max (O. A. Max)

The O. A. Max knob allows a reset up to the maximum outdoor air temperature specified by this knob setting. When the outdoor air temperature is above the specified setting, the unit will not function in the O.A. Reset Mode, but will continue to run at the selected set point temperature.

Note that the set point knob will now indicate the “minimum” boiler temperature. Target temperature is determined by the ratio and outdoor air temperature below the O.A. Max setting.

## 5 Electrical connections *(continued)*

### Ratio

The Ratio knob allows the control over the reset ratio to be used during Outdoor Air Reset. The allowable ratios are as low as 0.5:1 or as high as 1.5:1.

Selecting the 0.5:1 ratio will increase the set point 0.5°F for every 1.0°F drop in outdoor air temperature up to the maximum set point temperature.

Selecting the 1.5:1 ratio will increase the set point 1.5°F for every 1.0°F drop in outdoor air temperature up to the maximum set point temperature (see page 41).

See FIG. 5-13 for an outdoor air reset chart example.

### Temperature control sensors

This is a two-stage temperature control that controls the burner ignition, pump, and alarm functions. This temperature controller can measure up to three different sensor inputs, depending upon how the unit is set up. They are as follows:

1. Inlet Water Temperature Sensor
2. Multi-Purpose Temperature Sensor
3. Outside Air Temperature Sensor

#### Inlet water temperature sensor

This sensor measures the inlet water temperature coming into the unit.

#### Multi-purpose temperature sensor

This sensor can be used as a system sensor or a tank sensor.

#### Outdoor air temperature sensor

This sensor is only available on boiler units with an outdoor air reset option. This allows you to tie boiler operation to the outdoor air temperature. As outside temperatures drop, the control will increase the temperature setting of the boiler. As outdoor temperatures rise, the control will decrease the temperature to the selected set point of the boiler. You can set the control to shut the boiler off when a desired outdoor air temperature level is reached.

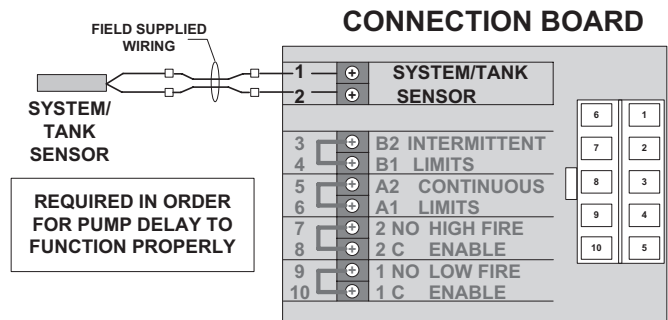
#### Remote sensor for pump delay

This appliance is provided with a special thermostat sensor that **MUST** be field installed. The sensor is shipped loose in the I & O packet. This remote mounted sensor will be the primary water sensor which will inform the appliance's built-in thermostat control. Reading the water temperature at the remote location is required for proper operation of the pump delay option provided with this appliance.

For domestic water heating, the sensor must be installed into a bulbwell on the storage tank. For boiler and hydronic heating, the sensor must be installed in the system piping loop. If the appliance is controlled by a remote sequencer, the sensor must be routed back into the appliance and placed in a bulbwell on the inlet side of the heat exchanger.

The sensor must be connected to two wires provided on the side of the appliance with the water connections (FIG. 5-12). It will be necessary to add additional wire to reach from the appliance to the remote water source. Use twisted pair wire or minimum 18 gauge wire or larger. Reference Table 5C on page 44 for a chart regarding distance versus wire gauge.

Figure 5-12\_Remote sensor for pump delay



### Boiler application

Standard boiler units are shipped with two sensors; the inlet water temperature sensor and the multi-purpose temperature sensor. The multi-purpose sensor should be used as a system sensor. Boilers with the outdoor air reset option also have an outside air temperature sensor.

### Water heater application

Water heater units are shipped with two sensors; the inlet water temperature sensor and the multi-purpose temperature sensor to be used as a tank sensor.

### Placement of sensors

#### Inlet temperature sensor

The inlet water temperature sensor is installed by the factory in new units. The sensor is an immersion style and maintains direct contact with the water.

#### System sensor

This is used for boiler applications. This sensor will control the boiler operation based upon the water temperature within the building loop.

#### Tank sensor

This is used in water heating applications. Place the sensor in the water storage tank to measure water temperature. For more information on mounting the sensor, see *Remote Mounting of a Sensor*, page 44.

## 5 Electrical connections

### Outdoor air Temperature sensor

The outside air temperature sensor will only be used for boiler systems. The outside air sensor is optional. You must purchase the sensor from the appliance manufacturer. The sensor comes with a housing that helps protect the sensor from the elements. Mount the air sensor housing under the eave of the roof. Make sure the housing is out of direct sunlight. This will ensure that the sensor will accurately read the true outdoor temperature. For more information on mounting the sensor, see *Remote Mounting of a Sensor*.

- Use shielded wiring to connect the sensor to the control when the possibility of an electrically noisy environment exists. Shielded cable is recommended on all cable runs of more than 25 feet in length.

#### NOTICE

Ground the cable shield at the connection to the boiler temperature control only. Do not ground the shielded cable at the sensor end.

To maintain temperature accuracy, sensor wires should be at least 18 AWG, see Table 5C.

Figure 5-13\_Outdoor air reset chart example

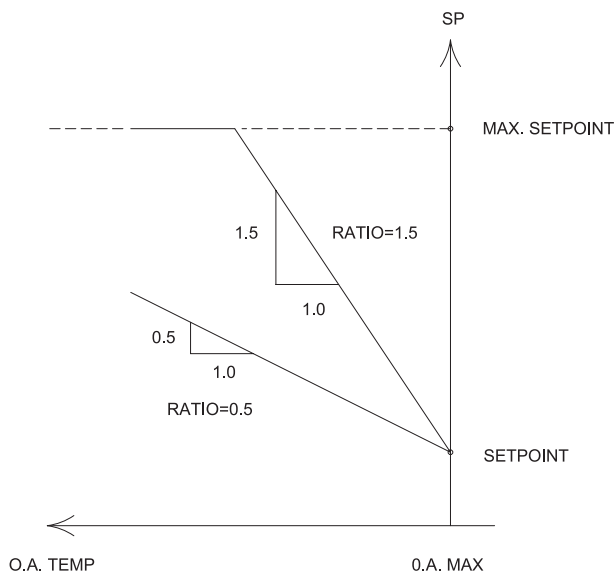


TABLE 5C  
Remote Wire Connection

Wire Gauge	Max. Allowable Length
12 GA	100 FT
14 GA	75 FT
16 GA	50 FT
18 GA	30 FT

### Remote mounting of a sensor

You must mount the outside air temperature sensor outside the building. To mount remote sensors, follow the guidelines below. Take care to correctly wire sensors to the unit. Erratic temperature readings can be caused by poor wiring practices. Twist the wires between the unit and the remote sensor. Turn wires at least three or four turns per linear foot of wiring. This provides common mode rejection of some types of electrical interferences.

- Do not route temperature sensor wiring with building power wiring.
- Do not locate temperature sensor wiring next to control contactors.
- Do not locate temperature sensor wiring near electric motors.
- Do not locate temperature sensor wiring near welding equipment.
- Make sure good mechanical connections are made to the sensor, any interconnecting wiring and the controller.
- Do not mount sensor with leadwire end pointing up in an area where condensation can occur.

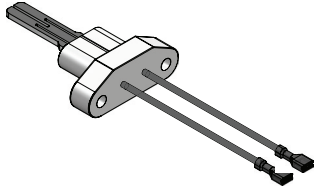
## 5 Electrical connections *(continued)*

### Hot surface ignition system

#### Hot surface igniter and ignition control module

This unit has one ignition module and one hot surface igniter.

**Figure 5-14**\_Hot surface igniter



#### ⚠ CAUTION

The igniter is extremely fragile, be very careful when removing. A faulty or damaged hot surface igniter **MUST BE** replaced with a Lochinvar **PLT3400** igniter. Do not use general purpose field replacement igniters.

#### Hot surface ignition control module

##### Ignition Module Lockout Functions

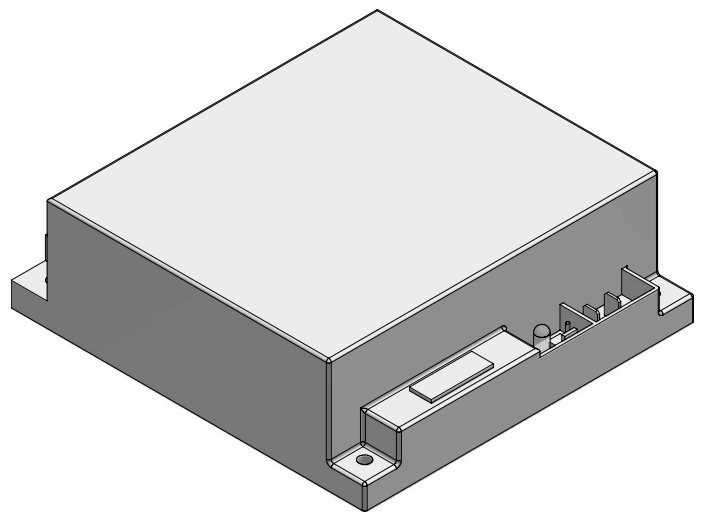
The ignition module may lockout in either a hard-lockout condition, requiring pushing of the reset button to recycle the control, or a soft-lockout condition which may recycle after an approximate five-minute waiting period. This soft-lockout condition is intended to allow self-correcting faults to correct themselves and permit normal operation. A typical hard-lockout fault is a flame failure condition. An ignition module that is in a hard-lockout condition may only be reset by pushing the reset button next to the ignition control or the “RESET” button on the diagnostic panel on the left end of the unit. Upon a flame failure, the reset button is only active after the control module has completed its post-purge cycle. Turning main power “OFF” and then “ON” or cycling the thermostat will not reset a hard-lockout condition. Wait five seconds after turning on main power before pushing the reset button when the ignition module is in a hard lockout. The ignition module will go into a soft lockout if conditions of low air, low voltage or low hot surface igniter current are present. A soft-lockout condition will operate the combustion air fans for the post purge cycle and then the ignition module will pause for approximately five minutes. At the end of this timed pause, the ignition module will attempt a new trial for ignition sequence. If the soft-lockout fault condition has subsided or has been corrected at the end of the timed pause, main burner ignition should be achieved with the resumption of the normal trial for ignition sequence. If the control sensed fault is not corrected, the ignition module will continue in the soft-lockout condition. If the electronic thermostat opens during the soft-lockout period, the ignition module will exit soft lockout and wait for a new call for heat from the thermostat. A soft-lockout condition may also be reset by manually cycling the thermostat or turning the main power switch “OFF” and then “ON” after the control sensed fault has been corrected.

#### Diagnostic Status Indication

The ignition module has an LED which indicates the status of the safety circuits. A remote Ignition Module Status indicating light is wired from the ignition module Status LED and mounted on the front diagnostic panel. The flashing operation of this light indicates the diagnostic status of the ignition control module. The status LED, mounted on the ignition module flashes a code sequence from the Ignition Module to indicate the status of the ignition process. See Table 5D for the flashing diagnostic status codes as signaled by the ignition module.

Note: Flame current is typically 2 - 6  $\mu$ A

**Figure 5-15**\_Hot surface ignition control module



## 5 Electrical connections

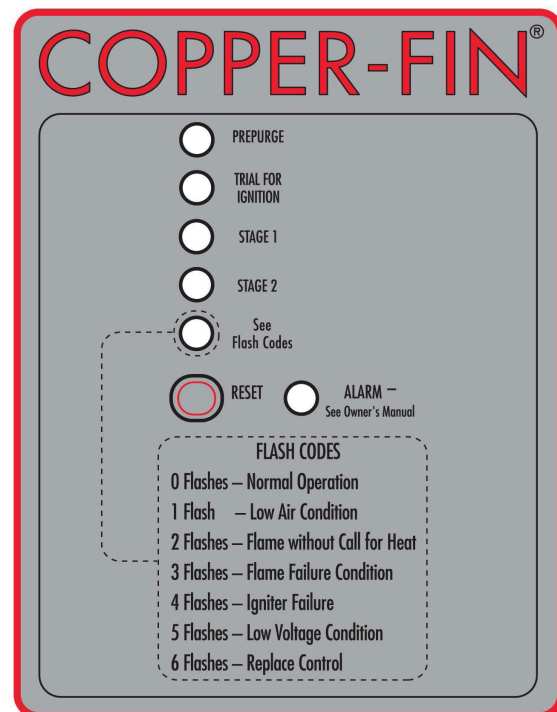
### Operation and diagnostic lights

The diagnostic control panel has up to 6 indicating and diagnostic lights to show all major steps of operation and control sensed malfunctions. This panel is located on the front of the unit.

TABLE 5D Status LED Diagnostic Codes	
Code Sequence	Condition
Constant ON	System OK, no faults present.
Constant OFF	Possible control fault, check power; LED may be defective, do not replace control if all operational sequences function properly, see Trouble- Shooting Guide.
One Flash	Low Air, check air pressure switch and hoses to pressure sensing points, fan, venting and sealing of pressurized chamber. Note: Brief flashing normal on fan start-up proving.
Two Flashes	Flame without call for heat, check for a gas valve stuck in the open position, air, venting, burners and the combustion process. Fan will remain on.
Three Flashes	Lockout due to flame failure, push reset button on the diagnostic panel after correcting ignition problem. Initial heater start up without properly bleeding air from the gas line may require multiple reset functions to achieve proper ignition.
Four Flashes	Igniter failure, igniter will not maintain a minimum 2.75 amp current draw, caused by low voltage, bad wiring/continuity, high resistance or igniter failure.
Five Flashes	Power supply problem, check for low supply voltage or transformer output less than 18VAC.
Six Flashes	Replace ignition module, internal fault.

TABLE 5E Status LED Diagnostic Codes	
Code Sequence	Condition Lights
Prepurge	Operation for combustion air fan before ignition on stages 1 and 2.
Trial for Ignition	Hot surface igniter preparing to light burners.
Stage 1 ON	Burners for stage 1 operating.
Stage 2 ON	Burners for stage 2 operating.
Status	Remote status light for ignition module.
Alarm	Indicates flame failure on the ignition module and will indicate additional alarms if the alarm of any failure option is purchased.

Figure 5-16\_ Operation / diagnostic lights



## 6 Startup

Figure 6-1\_Operating instructions

### FOR YOUR SAFETY READ BEFORE OPERATING

**WARNING:** If you do not follow these instructions exactly, a fire or explosion may result causing property damage, personal injury or loss of life.

A. This appliance is equipped with an ignition device which automatically lights the burner. Do not try to light the burner by hand.

B. BEFORE OPERATING smell all around the appliance area for gas. Be sure to smell next to the floor because some gas is heavier than air and will settle on the floor.

#### FOR YOUR SAFETY "WHAT TO DO IF YOU SMELL GAS"

- Do not try to light any appliance.
- Do not touch any electrical switch; do not use any phone in your building.
- Immediately call your gas supplier from a neighbor's phone. Follow the gas supplier's instructions.

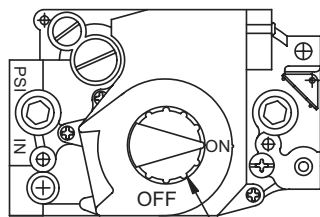
◦ If you cannot reach your gas supplier, call the fire department.

C. Use only your hand to turn the gas control knob. Never use tools. If the knob will not turn by hand, don't try to repair it, call a qualified service technician. Force or attempted repair may result in a fire or explosion.

D. Do not use this appliance if any part has been under water. Immediately call a qualified service technician to inspect the appliance and to replace any part of the control system and any gas control which has been under water.

### OPERATING INSTRUCTIONS

1. STOP! Read the safety information above on this label.
2. Turn off all electric power to the appliance.
3. Open control access panel.
4. This appliance is equipped with an ignition device which automatically lights the burner. Do not try to light the burner by hand.



GAS CONTROL KNOB  
SHOWN IN THE "ON" POSITION

5. Push in gas control knob slightly and turn clockwise to "OFF."



NOTE: On the 36C valve, knob cannot be turned to "OFF" unless knob is pushed in slightly. Do not force.

6. Wait five (5) minutes to clear out any gas. Then smell for gas, including near the floor. If you smell gas, STOP! Follow "B" in the safety information above on this label. If you don't smell gas, go to the next step".

7. Turn gas control knob counterclockwise to "ON."



8. Replace control access panel.
9. Turn on all electric power to the appliance.
10. If the appliance will not operate, follow the instructions "To Turn Off Gas To Appliance" and call your service technician or gas supplier.

### TO TURN OFF GAS TO APPLIANCE

1. Turn off all electric power to the appliance if service is to be performed.

2. Open control access panel.

3. Push in gas control knob slightly and turn clockwise to "OFF". Do not force.



4. Replace control access panel.

LBL2084 REV D

## 6 Startup

### Pre-Commissioning Cleaning

1. Prior to fill and start-up, flush the entire heating system.
2. Clean the entire heating system with an approved pre-commissioning cleaner (comparable to Sentinel X300 or Fernox F3) in accordance with the manufacturer's recommendation to remove debris and prolong the life of the heat exchanger.
3. Clean all water filtering devices in the system.
4. Flush the cleaning solution out of the entire system and refill.

### Fill water

#### Check/control fill water chemistry

##### IMPORTANT

Conduct water quality testing prior to installing the appliance. Various solutions are available to adjust water quality.

The manufacturer recommends the following for properly filling your boiler with the appropriate water chemistry for closed loop boilers. Good fill water quality will help extend the life of the appliance by reducing the effects of lime scale buildup and corrosion in closed loop systems.

#### Hardness between 5 and 15 grains per gallon

1. Consult local water treatment companies for hard water areas (above 15 grains per gallon hardness).
2. Hardness levels that are above 15 grains/gallon can lead to lime scale buildup throughout the boiler system. If the fill water is below 5 grains/gallons, usually due to use of a water softener, it is recommended to mix in some potable water at the inlet to increase the hardness of the water to above 5 grains/gallons.

#### pH between 6.5 and 8.5

1. pH levels below 6.5 can cause an increase in the rate of corrosion. pH of 8.5 or higher can potentially cause lime scale buildup.

#### Total Dissolved Solids (TDS) less than 350 ppm

1. Total dissolved solids are all minerals, salts, metals, and charged particles that are dissolved in water.
2. The greater the amounts of TDS present, the higher the corrosion potential due to increased conductivity in the water.

#### Chlorine concentration less than 150 ppm

1. Do not fill boiler or operate with water containing chlorine in excess of 150 ppm.
2. Filling with fresh drinking water should be acceptable.
3. Do not use the boiler to directly heat swimming pool or spa water.

### Boiler water

##### CAUTION

Do not use petroleum based cleaning or sealing compounds in the boiler system. Gaskets and seals in the system may be damaged. This can result in substantial property damage.

DO NOT use "homemade cures" or "boiler patent medicines". Serious damage to boiler, personnel, and/or property may result.

Table 6A Boiler Water Chemistry

BOILER WATER CHEMISTRY	
Specification	Range
Dissolved Solids	< 2000 ppm
pH Level	6.5 to 9.5
Chloride	< 150 ppm

- Monitoring pH, chlorides, TDS, and hardness levels can prolong the life of the appliance by reducing lime scale buildup, corrosion, and erosion. Check for leaks to ensure that fresh water is not entering the system.
- Continual fresh makeup water will reduce boiler life.
- Mineral buildup in the heat exchanger reduces heat transfer, overheats the stainless steel heat exchanger, and causes failure.
- The addition of oxygen carried in by makeup water can cause internal corrosion in system components.
- Leaks in the boiler or piping must be repaired at once to prevent excessive makeup water. For this purpose, it is recommended to install a water meter to easily check the amount of makeup water entering the system. Makeup water volume should not exceed 5% of the total system volume per year. **NOTE:** When makeup water is added, make sure the chemical additives are added to maintain the correct level.
- An approved multi-metal corrosion inhibitor (comparable to Sentinel X100 or Fernox F1) is recommended at the correct concentration and in the manner recommended by the manufacturer.

### Freeze protection for a heating boiler system (if required)

##### WARNING

Ethylene glycol is toxic, DO NOT use as your freeze protection. Ethylene glycol has a sweet aroma which children and pets could mistake as food and ingest; leading to death.

## 6 Startup *(continued)*

1. Use glycol only if needed for freeze protection.
2. Propylene glycol is the recommended freeze protection.
3. Make sure to flush the boiler system before adding glycol.
4. Determine the freeze protection fluid quantity using system water content, following the fluid manufacturer's instructions. Boiler water content is listed on page 6. Remember to include expansion tank water content.
5. Local codes may require a backflow preventer or actual disconnect from city water supply.
6. When using freeze protection fluid with automatic fill, it is suggested to install a water meter to monitor water makeup. Freeze protection fluid may leak before the water begins to leak, causing the concentration to drop, which reduces the freeze protection level.
7. The freeze protection set points may be lowered when freeze protection fluid is used (see the Copper-Fin Service Manual).
8. Consult the glycol manufacturer for details on the suggested mix of glycol and water for the desired freeze protection level and the de-rate effect it will have on the boiler output.

### Test / replace freeze protection fluid

1. For systems using freeze protection fluids, follow the fluid manufacturer's instructions.
2. Freeze protection fluid must be replaced periodically due to degradation of inhibitors over time.
3. It is recommended to test the glycol concentration annually and adjust within the desired set points.

### Oxygen prevention

#### CAUTION

Eliminate all system leaks. Continual fresh makeup water will reduce boiler life. Minerals can build up in the heat exchanger, reducing heat transfer, overheating the heat exchanger, and causing heat exchanger failure.

Dissolved oxygen can have a negative effect on the boiler system. Oxygen can cause iron oxide to generate iron deposits. Oxygen may also increase the rate of corrosion on non-stainless steel parts of the system. A low pH level combined with oxygen further enhances its corrosive effects. After boiler installation, check for air leaks in the following areas:

- Suction gasket
- Pump
- Air valve
- O-ring gaskets

Precautions include installing a water meter to evaluate the fresh water volume entering the system (should be no more than 5% system volume). Additional volumes of fresh water could indicate that a leak is present.

### Fill and test water system

1. Fill system only after ensuring the water meets the requirements of this manual.
2. Close automatic and manual air vents and boiler drain valve.
3. Fill to correct system pressure. Correct pressure will vary with each application.
  - a. The minimum cold water fill pressure for a system is 12 psi.
  - b. Pressure will rise when the boiler is turned ON and system water temperature increases.
4. At initial fill and during boiler startup and testing, check the system thoroughly for any leaks. Repair all leaks before proceeding further.

### Purge air from water system

1. Purge air from system:
  - a. Connect a hose to the purge valve (see purge/drain valve in the piping diagrams on pages 42 through 47). Route the hose to an area where water can drain and be seen.
  - b. Close the boiler or system isolation valve between the purge valve and fill connection to the system.
  - c. Close zone isolation valves.
  - d. Open the quick-fill valve on the cold water makeup line.
  - e. Open purge valve.
  - f. Open the isolation valves one zone at a time. Allow water to run through the zone, pushing out the air. Run until no noticeable air flow is present. Close the zone isolation valves and proceed with the next zone. Follow this procedure until all zones are purged.
  - g. Close the quick-fill water valve and purge valve and remove the hose. Open all isolation valves. Watch that system pressure rises to correct cold-fill pressure.
  - h. After the system has operated for a while, eliminate any residual air by using the manual air vents located throughout the system.
  - i. If purge valves are not installed in the system, open the manual air vents in the system one at a time, beginning with the lowest floor. Close the vent when water squirts out. Repeat with remaining vents.
2. Open the automatic air vent (diaphragm-type or bladder type expansion tank systems only) one turn.
3. Open other vents:
  - a. Starting on the lowest floor, open air vents one at a time until water squirts out.
  - b. Repeat with remaining vents.
4. Refill to correct pressure.

## 6 Startup

### Check for gas leaks

#### ⚠ WARNING

Before starting the boiler, and during initial operation, smell near the floor and around the boiler for gas odorant or any unusual odor. Remove the front access panel and smell the interior of the boiler enclosure. Do not proceed with startup if there is any indication of a gas leak. Use an approved leak detection solution. Repair any leaks at once.

#### ⚠ WARNING

Propane boilers only – Your propane supplier mixes an odorant with the propane to make its presence detectable. In some instances, the odorant can fade, and the gas may no longer have an odor. Before startup (and periodically thereafter), have the propane supplier verify the correct odorant level in the gas.

### Check thermostat circuit(s)

1. Disconnect the two external wires connected to the enable terminals on the connection board.
2. Connect a voltmeter across these two incoming wires. Close each thermostat, zone valve, and relay in the external circuit one at a time and check the voltmeter reading across the incoming wires.
3. There should NEVER be a voltage reading.
4. If a voltage does occur under any condition, check and correct the external wiring. (This is a common problem when using 3-wire zone valves.)
5. Once the external thermostat circuit wiring is checked and corrected if necessary, reconnect the external thermostat circuit wires to the connection board. Allow the boiler to cycle.

### Check vent and air piping

1. Inspect vent piping and air piping for signs of deterioration from corrosion, physical damage or sagging. Verify air piping and vent piping are intact and correctly installed per this manual.

### Placing the boiler in operation

#### Boiler operational checks

2. Turn the boiler main power switch to the “ON” position.
3. Confirm the settings of the temperature control.
4. Push the reset for the low water cutoff (if equipped).
5. Ensure that maximum flow to the boiler does not exceed 55 GPM on Models 497 - 747 and 90 GPM on Models 987 - 2067. Verify by checking temperature rise while burner is firing at 100% of rated input.
6. Install a manometer on the gas supply to the boiler and verify minimum gas supply pressure as the burner fires at 100% of rated input.
7. Verify operation of safeties as necessary (low water cutoff, high limit, gas pressure, etc.,).

### Boiler operation

8. Verify that all adjustable points in the Operator Interface are set as required.
9. Boiler should begin the start-up process for the sequence of operation.
10. The boiler will ignite and operate to meet the system demand.

When the boiler has been firing for several minutes with all burners on (full fire), the flue products should be in the range listed in Table 6B below. The CO levels shall be less than 200 ppm for a properly installed unit.

11. Ensure that inlet water temperature does not fall below the specified minimum for the boiler.
12. As system demand is satisfied, the burner will cycle off and the combustion air blower will run for a post purge operation before the boiler shuts down.

### Start the boiler

1. Read and follow the Lighting Instructions in FIG. 6-1, on page 47.

### If boiler does not start correctly

1. Check for loose connections, blown fuse or service switch off?
2. Is external limit control (if used) open? Is boiler water temperature above 230°F (110°C)?
3. Is thermostat set below room temperature?
4. Is gas turned on at meter or boiler?
5. Is incoming gas pressure less than 4 inches water column?

If none of the above corrects the problem, refer to the Maintenance Section of this manual.

#### ⚠ WARNING

The venting system must be installed so that it will prevent flue gas spillage and carbon monoxide emissions, which will result in severe personal injury or death.

Table 6B Flue Products Chart

Natural Gas		Propane	
CO <sub>2</sub>	O <sub>2</sub>	CO <sub>2</sub>	O <sub>2</sub>
7.8% - 9.8%	3.5% - 7.0%	8.1% - 10.3%	5.1% - 8.5%
<b>CO levels shall be less than 200 ppm.</b>			

# 7 Domestic water heaters

This section applies only to those units used to supply potable hot water for domestic use. The water heater must be installed with a storage tank.

This section contains specific instructions for those units used to supply domestic hot water. All warnings, cautions, notes and instructions in the general installation and service sections apply to these instructions. Water heaters are designed for installation with a properly sized storage tank. The use of a properly sized pump and the control of water velocity, as explained below, are important for correct operation of your water heater.

## Water velocity control

### NOTICE

To ensure proper velocity through the heat exchanger, you must regulate the temperature rise across the heat exchanger from inlet to outlet. Do this upon initial installation and periodically recheck.

The correct temperature rise across the heat exchanger ensures proper velocity in the tubes. This will yield long life and economical operation from your hot water heater. Excessive lime build up in the tube is caused by too low velocity through the tubes. Excessive pitting or erosion in the tube is caused by too high velocity through the tubes. Take care to measure temperature rise and maintain a velocity as follows:

## Initial set-up of maximum water flow

On initial start-up, the maximum water flow through the heat exchanger must be manually set before normal operation begins.

**TABLE - 7A**  
MAXIMUM WATER FLOW

**⚠ CAUTION: The maximum flow rate through a water heater with a copper heat exchanger must be set to provide and not exceed the following flow:**

Model	Maximum Flow	Maximum Flow for CuNi Heat Exchanger
497, 647, and 747	55 GPM	75 GPM
987, 1257, 1437, 1797, and 2067	90 GPM	115 GPM

The heat exchanger is capable of operating within the design flow rates required for the water heater, storage tank(s), and connecting piping. Erosion of the finned copper tubes may occur if the flow rate exceeds the maximum allowable flow rate through the water heater. The maximum flow rate through the water heater must be adjusted. Flow rate can be determined by measuring the temperature rise through the water heater when it is firing at full rate input.

### NOTICE

When connecting the unit to piping made of a different material, use of a dielectric fitting or a dielectric union conforming to ASSE 1079 is recommended to prevent corrosion and potential subsequent water leaks at or near the connection. Dielectric fittings may be required by local plumbing codes.

**TABLE 7B**  
Temperature Rise Chart

Model	Temperature Rise
497	15°F
647	19°F
747	22°F
987	18°F
1257	23°F
1437	26°F
1797	32°F
2067	37°F

1. With the pump running and the water heater off, the inlet and outlet thermometers should read the same temperatures. If they do not, an adjustment must be made to your final calculation.
2. Turn the water heater "On" and allow time for the temperature to stabilize. Record the difference between the inlet and outlet temperatures. This difference will be the "temperature rise".
3. Compare the temperature rise on the heater with the required temperature rise in Table 7B. Should adjustment be needed, proceed as follows:

**If the temperature rise is too high, the water velocity is too low. Check the following:**

1. Check for restrictions in the outlet of the water heater.
2. Be sure all valves are open between the water heater and the tank.
3. Check the pump to be sure it is running properly and that the pump motor is running in the proper direction (see arrow on volute housing).
4. Be sure the installed circulation pipes between the water heater and storage tank are not less than 2 1/2" in diameter on Models 987 - 2067.
5. Common manifold piping for multiple unit installations will require larger minimum pipe sizes and tank circulating tappings to ensure proper flow. See Table 7C on page 56.

**If the temperature rise is too low, the water velocity is too high. Adjust as follows:**

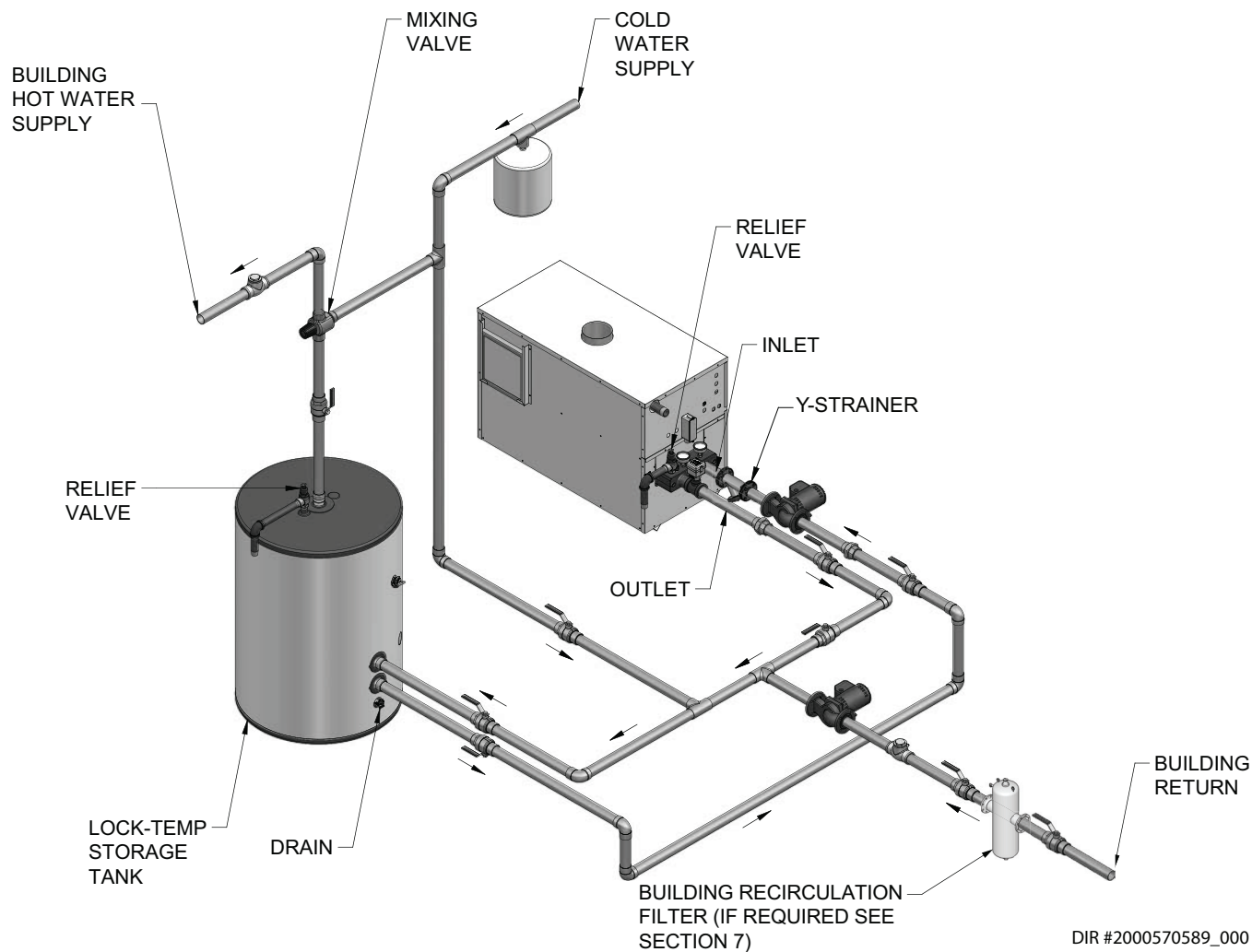
1. Slowly throttle the valve on the outlet side of the water heater until the temperature rise is steady at the required temperature rise as noted in Table 7A.
2. Sustained high water velocity and low temperature rise may result in pitting or erosion of the copper tubes in the heat exchanger. This is a non-warrantable failure. Temperature rise must be properly adjusted to achieve the specified flow rate.

# 7 Domestic water heaters

Figure 7-1\_Typical water heater piping with storage tank

COMMON MANIFOLD SIZE (Min.) Models: 497 - 747		
Number of Units	GPM	Diameter (in.)
1	60	2 1/2

COMMON MANIFOLD SIZE (Min.) Models: 987 - 2067		
Number of Units	GPM	Diameter (in.)
1	90	2 1/2



DIR #2000570589\_000

## NOTICE

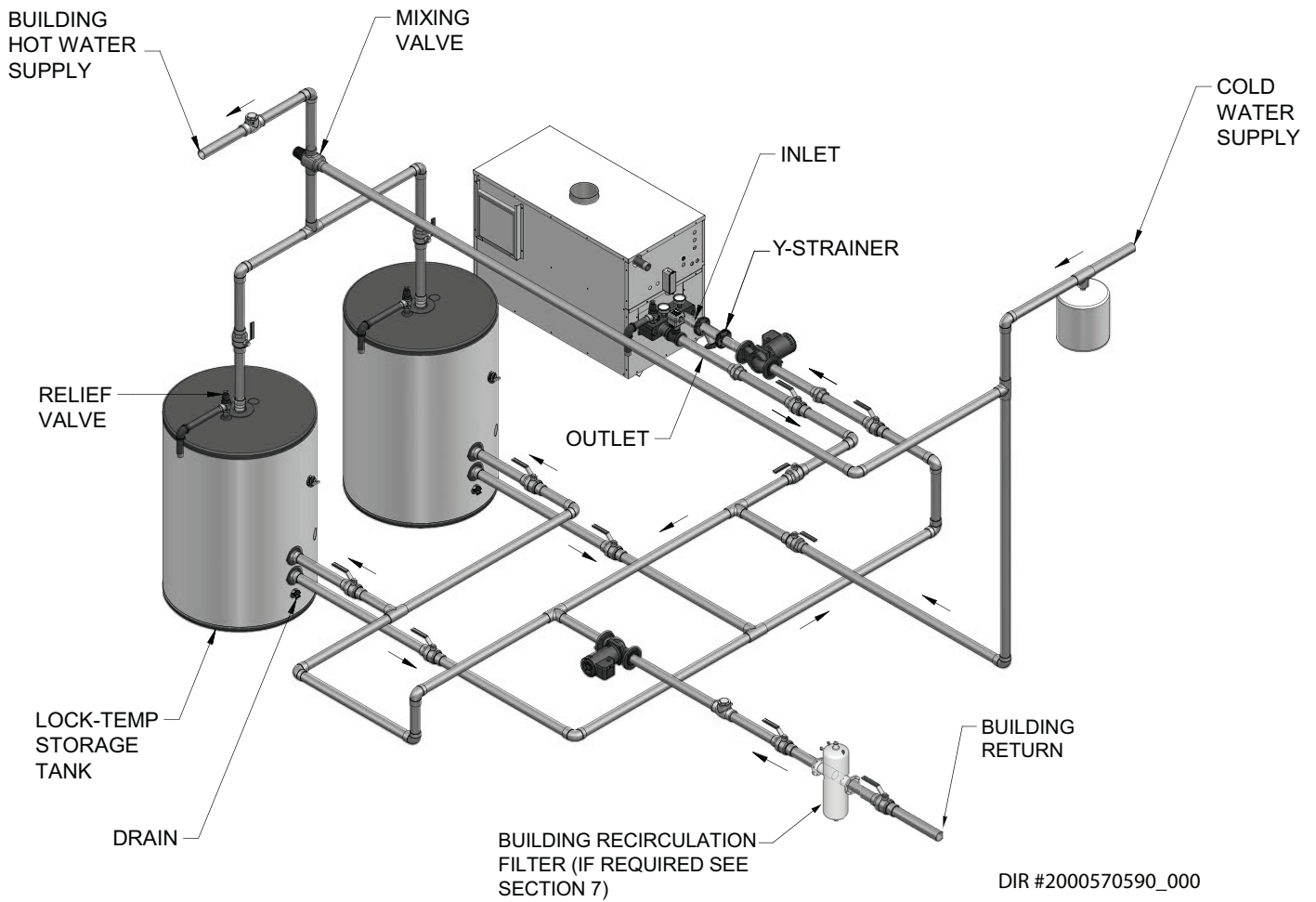
\*Please note that these illustrations are meant to show system piping concept only, the installer is responsible for all equipment and detailing required by local codes.

# 7 Domestic water heaters *(continued)*

Figure 7-2\_Single water heater piping with two storage tanks

COMMON MANIFOLD SIZE (Min.) Models: 497 - 747		
Number of Units	GPM	Diameter (in.)
1	60	2 1/2

COMMON MANIFOLD SIZE (Min.) Models: 987 - 2067		
Number of Units	GPM	Diameter (in.)
1	90	2 1/2



DIR #2000570590\_000

**NOTICE**

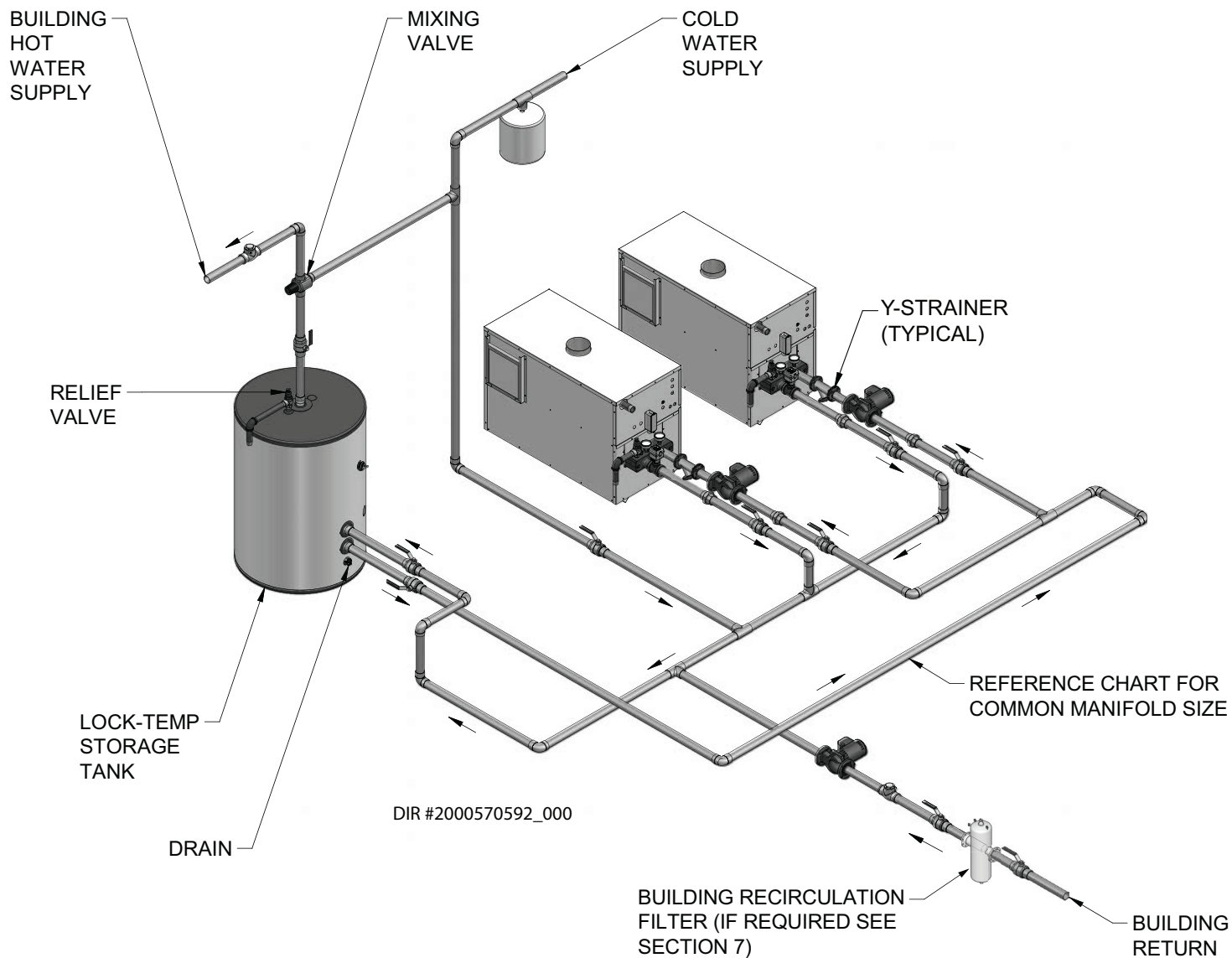
\*Please note that these illustrations are meant to show system piping concept only, the installer is responsible for all equipment and detailing required by local codes.

## 7 Domestic water heaters

Figure 7-3\_Multiple water heater piping with a single storage tank

COMMON MANIFOLD SIZE (Min.) Models: 497 - 747		
Number of Units	GPM	Diameter (in.)
2	120	3 1/2
3	180	4
4	240	5
5	300	5
6	360	6
7	420	6
8	480	6

COMMON MANIFOLD SIZE (Min.) Models: 987 - 2067		
Number of Units	GPM	Diameter (in.)
2	180	4
3	270	5
4	360	6
5	450	6
6	540	6
7	630	8
8	720	8



### NOTICE

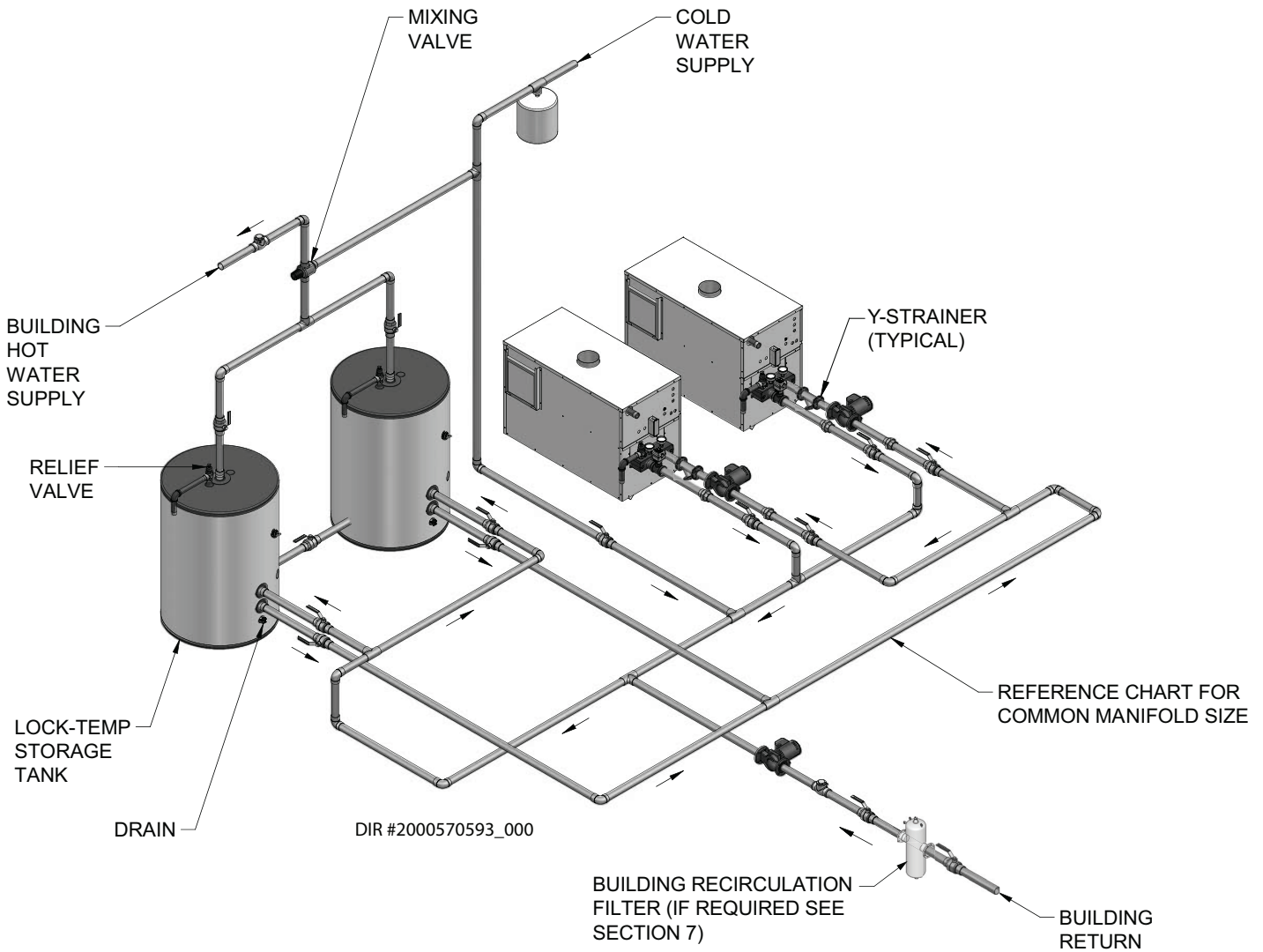
\*Please note that these illustrations are meant to show system piping concept only, the installer is responsible for all equipment and detailing required by local codes.

# 7 Domestic water heaters *(continued)*

Figure 7-4\_Multiple water heater piping with multiple storage tanks

COMMON MANIFOLD SIZE (Min.) Models: 497 - 747		
Number of Units	GPM	Diameter (in.)
2	120	3 1/2
3	180	4
4	240	5
5	300	5
6	360	6
7	420	6
8	480	6

COMMON MANIFOLD SIZE (Min.) Models: 987 - 2067		
Number of Units	GPM	Diameter (in.)
2	180	4
3	270	5
4	360	6
5	450	6
6	540	6
7	630	8
8	720	8



**NOTICE**

\*Please note that these illustrations are meant to show system piping concept only, the installer is responsible for all equipment and detailing required by local codes.

## 7 Domestic water heaters

### Required temperature rise

Based on heating potable water with a hardness of 5 to 20 grains per gallon and/or total dissolved solids not exceeding 350 ppm, see *Water Chemistry*, this page.

### Water chemistry

The required temperature rise and the standard pump sizing are based on the heating of potable water with a hardness of 5 to 20 grains per gallon and a total dissolved solids not exceeding 350 ppm. Consult the appliance manufacturer when heating potable water exceeding these specifications.

Heating of high hardness and/or high total dissolved solids water will require a larger circulating pump, an optional cupro-nickel heat exchanger and a revised temperature rise specification based on the water chemistry of the water to be heated.

Water with a hardness of less than 5 grains per gallon will usually have a low pH which can be aggressive and corrosive causing non-warrantable damage to the heater, pump and associated piping. Corrosion due to water chemistry generally shows up first in the hot water system because heated water increases the rate of corrosive chemical reactions.

### Pipe size requirements

Table 7B, pipe sizing chart provides the minimum pipe size for common manifold piping to ensure adequate flow.

#### NOTICE

1. Do not use the appliance to directly heat swimming pool or spa water.
2. At initial fill and during water heater start-up and testing, check system thoroughly for any leaks. Repair all leaks before proceeding further.
3. When water hardness levels are less than 5 gpg or 85.5 mg/l, the following is recommended:
  - a. Flush and clean existing water heating system prior to installation.
  - b. Inspect and, if necessary, replace the anodes in any existing tanks.
  - c. Install a Y-strainer on the inlet of each water heater as detailed in this section.
  - d. Limit the run time of the hot water recirculation loop.
  - e. Filter the hot water recirculation loop to a level of 10 microns. CAUTION: Check recirculation pump size to verify it is sized for filter addition and upsize if necessary.
4. When water softener is required, a Template Assisted Crystallization system is recommended.

**TABLE 7C**  
**Pipe Sizing Chart**

497 - 747		987 - 2067	
Number of Units	Common Pipe Size (Min.)	Number of Units	Common Pipe Size (Min.)
1	2"	1	2 1/2"
2	3"	2	4"
3	3"	3	4"
4	4"	4	5"
5	5"	5	6"
6	5"	6	6"

### Circulating pump

1. The water heater must be connected to a properly sized pump that circulates water between the heater and storage tank.
2. The pump is sized to heater input and water hardness. Care should be taken to size the pump correctly. See *Water Chemistry*, this page.
3. The water heater is equipped with a factory-supplied pump delay system in accordance with the requirements of the latest edition of ASHRAE 90.1.
4. Lubricate the pump to the manufacturer's recommendations. Pump damage due to inadequate lubrication is non-warrantable.
5. Standard water heaters are furnished with the following circulating pump. Mount the pump on the unit's inlet water connection.

#### Models 497 - 747

**1/4 HP, 120 VAC, 5.8 Amps**

#### Models 987 - 2067

**1/2 HP, 120 VAC, 7.4 Amps**

This pump is sized based on installation of a single storage tank and heater in close proximity. If the number of fittings and straight pipe exceeds the quantities shown in this section, a larger pump will be required.

The standard pump selection is based on the following pipe and fittings from the unit to the storage tank:

- 6 90° elbows
- 2 ball valves
- 2 unions
- 1 cold water tee
- No more than 45 feet of straight pipe.

#### NOTICE

For every elbow and tee in excess of those shown above, deduct 5 feet from maximum allowable straight pipe in heater to tank circulating loop.

# 7 Domestic water heaters *(continued)*

## Minimum pump performance

This is based on heating potable water with a hardness of 5 to 25 grains per gallon and/or total dissolved solids not exceeding 350 ppm. See *Water Chemistry*, page 56.

Model	Pipe Size	Water Hardness	Grundfos Pump	Flow Rate (GPM)	Head Loss (FT)	Temp. Rise
497	2"	5 to 15 gpg	TP44PAB	55	10	15°F
		15 to 20 gpg	UP 43-110 SF	75	10	11°F
647	2"	5 to 15 gpg	TP44PAB	55	10	19°F
		15 to 20 gpg	UP 43-110 SF	75	10	14°F
747	2"	5 to 15 gpg	TP44PAB	55	10	22°F
		15 to 20 gpg	UP 43-110 SF	75	10	16°F
987	2-1/2"	5 to 15 gpg	TP24PAB	90	15	18°F
		15 to 20 gpg	TP 50-160/2B	115	15	14°F
1257	2-1/2"	5 to 15 gpg	TP24PAB	90	15	23°F
		15 to 20 gpg	TP 50-160/2B	115	15	18°F
1437	2-1/2"	5 to 15 gpg	TP24PAB	90	15	26°F
		15 to 20 gpg	TP 50-160/2B	115	15	21°F
1797	2-1/2"	5 to 15 gpg	TP24PAB	90	15	32°F
		15 to 20 gpg	TP 50-160/2B	115	15	26°F
2067	2-1/2"	5 to 15 gpg	TP24PAB	90	15	37°F
		15 to 20 gpg	TP 50-160/2B	115	15	30°F

## Heat exchanger

On all models, header inspection plugs can be removed for field inspection and cleaning of copper tubes. The entire heat exchanger may be easily removed from the unit.

## Potable hot water temperature control settings

### Domestic water temperature

**⚠ WARNING** You must take adequate care to prevent scald injury when storing water at elevated temperatures for domestic use.

This unit has an adjustable temperature control to maintain the desired water temperature set point. See *Setting Temperature Control*, page 41, for instructions to adjust the temperature control. The temperature control is factory preset at approximately 125°F (52°C) or less. Households with small children or invalids may require 120°F (49°C) or lower temperature hot water to reduce risk of scald injury.

Operate this high efficiency hot water heater at a temperature setting high enough to prevent condensing of the products of combustion on the unit's heat exchanger or in the attached venting system. A water temperature setting that is above the dew point of the gas combustion products should prevent condensate formation.

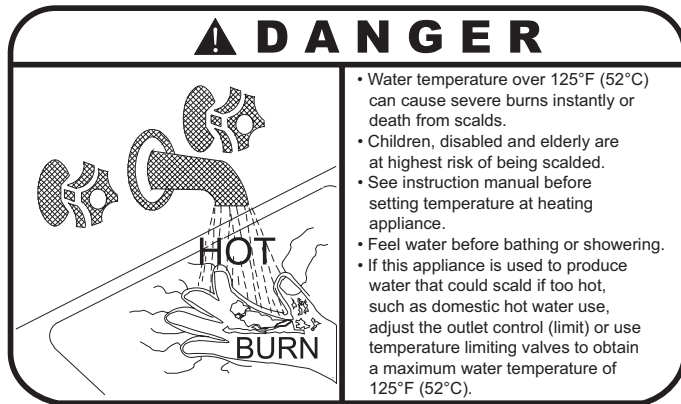
**⚠ WARNING** To guard against scald injury, you must use a properly sized thermostatic mixing valve to supply domestic hot water at temperatures less than 125°F (52°C).

**⚠ WARNING** Return water temperatures must not be less than 140°F (60°C). If lower return water temperatures are required, follow the instructions for *Low Temperature Return Water Systems*, page 32.

## 7 Domestic water heaters

Storing the water at a higher temperature and thermostatically mixing the water increases the available quantity of mixed hot water, greatly reducing the possibility of condensate forming on the heat exchanger or in the venting system and helps prevent water born bacteria growth.

Some states may require a lower water temperature setting for specific applications. Check local codes or your gas supplier for domestic hot water temperature requirements.



Remember, no water heating system provides exact temperatures at all times. Let the system operate a few days at your desired settings to determine correct settings for your needs.

1. These units are equipped with an operating temperature control.
2. The control set points are preset to a low test setting when shipped from the factory.
3. Reset the temperature set points to the lowest settings which will satisfy hot water demands, eliminate a possible condensate problem and prevent a risk of scald injury.
4. The High-Fire Offset should normally be adjusted to “0” when supplying potable hot water for domestic use.
5. Stage firing can be achieved by adjusting the High-Fire Offset to any value other than zero. Typically, a setting of 3°F is 5°F is suitable for stage firing in a water heater application. Stage firing of a potable water heater is normally only used to replace system standby heat loss.
6. All stages of burner operation should fire when there is a major draw from the potable hot water storage system. This prevents possible condensate problems and ensures a rapid recovery of the hot water used.

### NOTICE

The High-Fire stage will be delayed by approximately 10 seconds to allow a soft start of the water heater.

### WARNING

When water is stored at temperatures above 125°F (52°C), a thermostatic mixing valve must be installed on the hot water outlet from the storage tank to supply lower temperature water and prevent the risk of a scald injury.

### NOTICE

This water heater, when set at a lower temperature setting, is not capable of producing hot water of sufficient temperature for sanitizing purposes.

### Location of cold water supply piping connections

Incorrect piping of the cold water supply to the system may result in excessive low temperature operation causing condensate formation on the heat exchanger and operational problems. You must install the cold water supply piping in the discharge piping from the heater to the storage tank. This allows the cold water to be tempered in the storage tank before entering the heater. See FIG. 7-1, on page 52, and typical installation drawings provided with the unit for correct piping. Higher water temperatures reduce condensate formation.

### WARNING

Should overheating occur or the gas supply fail to shut off, do not turn off or disconnect the electrical supply to the pump. Instead, shut off the gas supply at a location external to the unit.

## 7 Domestic water heaters *(continued)*

### High water temperature limit control

The unit is equipped with an adjustable setting, auto-reset high water temperature limit control. The hot water heater temperature limit control has a maximum limit setting of 200°F (93°C). If water temperature exceeds the set point, the limit will break the control circuit and shut down the unit. The limit control will only be reset after the water temperature has cooled below the set point of the limit. The high water temperature limit control is mounted in the outlet side of the front header. A manual reset high water temperature limit control is available as an optional control.

### Optional relief valve

This water heater is normally supplied with a temperature and pressure relief valve(s) sized in accordance with applicable codes. Units may be supplied with an optional pressure only relief valve(s). When a water heater equipped with this optional relief valve is piped to a separate storage vessel, the storage vessel **MUST** have a properly installed temperature and pressure relief valve which complies with local codes.

### Thermal expansion

A relief valve which discharges periodically may be due to thermal expansion in a closed system. A hot water supply boiler installed in a closed system, such as one with a backflow preventer or check valve installed in the cold water supply, shall be provided with means to control expansion. Contact the water supplier or local plumbing inspector on how to correct this situation. Do not plug or cap the relief valve discharge!

### Cathodic protection

Hydrogen gas, which is extremely flammable, can be produced in a hot water system that has been unused for a long period of time (generally two weeks or more). To prevent the possibility of injury under these conditions, open the kitchen sink hot water faucet for several minutes before using any electrical appliance connected to the hot water system. If hydrogen is present, there will be an unusual sound such as air escaping through the pipe as the hot water begins to flow. Do not smoke or have open flames near the faucet at this time.

## 8 Maintenance

Listed below are items that must be checked to ensure safe, reliable operations. Verify proper installation after servicing.

### ⚠ CAUTION

Label all wires prior to disconnection when servicing controls. Wiring errors can cause improper and dangerous operation.

### Appliance area

Keep appliance area clear and free from combustible materials, gasoline and other flammable vapors and liquids.

### Water circulating pump

Inspect pump every six months and oil as necessary. Use SAE 30 non-detergent oil or lubricant specified by pump manufacturer.

### Burner flames

Visually check main burner flames at each start up after long shutdown periods or at least every six months. Burner viewports are located on the right and left sides of the unit.

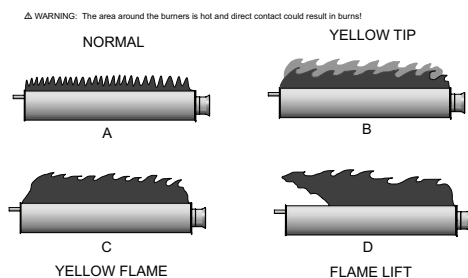
### Check fill water meter

Check fill water meter for water usage. If the amount exceeds 5% of your system volume, you could have a leak. Have the system checked for leaks and fixed by a qualified service technician.

### Test boiler water

Test boiler water. Reference the Copper-Fin Installation and Operation Manual for guidelines. When test indicates, clean system water with approved system restorer following the manufacturer's information.

Figure 8-1\_Flame patterns



### ⚠ WARNING

The areas around the burner viewports are hot. Direct contact with the unit could result in burns.

**Normal Flame:** A normal flame is blue with slight yellow tips, has a well-defined inner cone, and displays no lifting flames.

**Yellow Tips:** The usual causes for yellow tips on the burner flame are burner air flow blockage or partial obstruction.

**Yellow Flames:** The usual causes for yellow flames are primary air flow blockage to the burner(s) or excessive gas input. Correct this condition immediately.

**Lifting Flames:** The usual causes for lifting flames are over firing the burner(s), excessive primary air, or high draft.

If you observe improper flame patterns, examine the venting system, ensure proper gas supply, and ensure adequate supply of combustion and ventilation air.

### Flue gas passageways cleaning procedure

Any sign of soot around the outer jacket, at the burners or in the areas between the fins on the copper heat exchanger indicates a need for cleaning. The following cleaning procedures must only be performed by a qualified serviceman or installer. Proper service is required to maintain safe operation. Properly installed and adjusted units seldom need flue cleaning.

### NOTICE

All gaskets on disassembled components must be replaced with new gaskets on reassembly. Gasket kits are available from your distributor.

### Burner removal and cleaning

1. Turn off main power to unit.
2. Turn off main manual gas shutoff to unit.
3. Remove the front outer jacket panels.
4. Disconnect manifold from gas train using union(s) just below each gas valve(s).
5. Remove mounting screws from manifold mounting brackets. Pull the manifold/orifice assembly away from burners. Repeat for each manifold assembly.
6. Remove two mounting screws from burner and slide burner out toward front of unit. Use caution to prevent damage to burners, refractory, hot surface igniter or wiring.
7. Remove soot from burners with a stiff bristle brush.

Dirt may be removed from burner ports by rinsing the burner thoroughly with water. Drain and dry burners before re-installing. Damaged burners must be replaced.

When installed in a dusty and dirty location, the burners may require cleaning on a 3 to 6 month schedule or as needed, based on severity of contamination. Contaminants can be drawn in with the combustion air. Non combustible particulate matter such as dust, dirt, concrete dust or dry wall dust can block burner ports and cause non-warrantable failure. The standard inlet air filter will help eliminate dust and dirt from entering the unit. Use extreme care when operating a unit for temporary heat during new construction. The burners could require a thorough cleaning before the unit is placed in service.

## 8 Maintenance *(continued)*

### Heat exchanger cleaning

1. While burners are removed, check the heat exchanger surface for sooting. If present, heat exchanger must be cleaned and problem corrected. Proceed as follows.
2. Remove gas manifold(s)/orifice assemblies as described in steps 1 through 5 in Burner Removal and Cleaning, page 60.
3. Disconnect wiring from the hot surface igniter and hose from the burner pressure tap.
4. Remove inner jacket panel mounting screws and slide door assembly out toward front of the unit. Use caution to prevent damage to the refractory and hot surface igniter.
5. Check "V" baffles and frame runners along front and back edges of heat exchanger. Remove and clean if necessary.
6. Remove soot from heat exchanger with a stiff bristle brush. Use a vacuum to remove loose soot from surfaces and inner chamber.
7. The heat exchanger can be removed by sliding towards the front of the unit. Once the heat exchanger is removed from the unit, a garden hose can be used to wash the tubes to ensure that all soot is removed from the heat exchanger surfaces. Note: Do not wet the unit's refractory.
8. Ensure that all burner ports are cleaned to remove any soot. See Burner Removal and Cleaning, page 60.
9. Carefully reinstall the heat exchanger, "V" baffles, and frame runners if removed from the unit. Note: Make sure frame runners seal securely where they contact the front and rear compartment refractory.
10. Carefully reinstall inner jacket panels, burners, manifolds, wires and hoses. Use new gasket material to ensure a proper air seal.
11. Reassemble all gas and water piping. Test for gas leaks.
12. Reassemble outer jacket panels.
13. Cycle unit and check for proper operation.

### Electrical

This unit uses a transformer to supply a low voltage control circuit. The voltage on the secondary side should be 24 to 28VAC when measured with a volt meter. Larger models have a 7AMP circuit breaker provided on the secondary side of the transformer. A tripped circuit breaker indicates a short in the 24VAC controls that must be corrected.

### Combustion and ventilation air

#### Combustion air filter

See *Combustion Air Filter*, page 13.

#### Air flow

Check frequently to be sure the flow of combustion and ventilation air to the unit is not obstructed.

#### Combustion air fan

These units use a fan-assisted combustion process. These units have one fan to supply combustion air to the burners.

#### Fan cleaning

Check combustion air fan every six months. Clean fan as required only when installed in a dusty or dirty location. Oiling is not required.

#### Combustion air fan adjustment

The combustion air fan is factory preset and should not need adjustment in most cases. Follow the steps below to adjust the fan if a continuous Low Air Status Code occurs.

Check for proper installation and draft in the venting system. Correct as required.

#### Adjusting air pressure

The following is a recommended method for setting the air pressure for the fan.

#### Setup procedure

To the left of the fan is an air pressure switch with a large and small tube delivering pressure from points inside the unit (see FIG. 8-2). The pressure in the large tube is the chamber pressure. By disconnecting the cap from the tee in the hose and connecting it to the "(+)" side of a manometer, you can read the air chamber pressure.

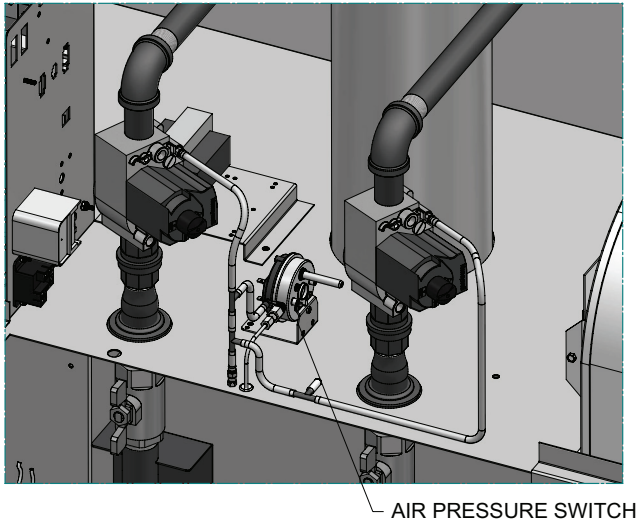
Upon a call for heat, the fan will run for about 90 seconds before going into soft lockout. If necessary, turn the power to the unit OFF and then back ON again to recycle the fan.

**Note:** If the unit has been firing recently, allow the unit to cool for five minutes with the fan running before beginning the adjustment procedure.

**Note:** Retain the plastic cap removed from the tee for reinstallation when complete.

## 8 Maintenance

**Figure 8-2\_Air pressure switch**



### Adjustment procedure Models 497 - 1257:

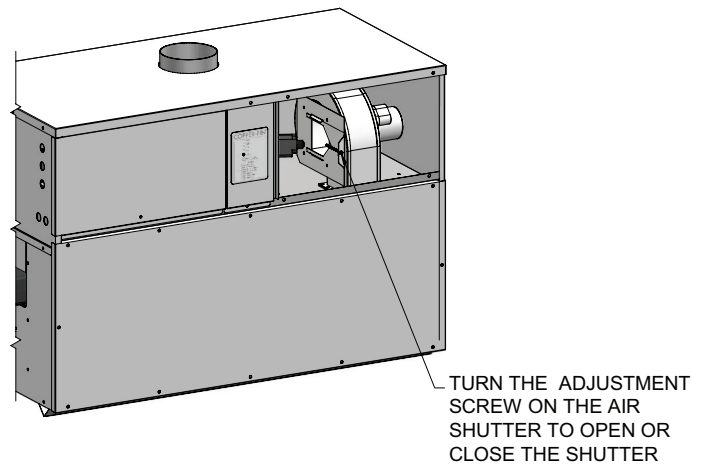
1. Remove the upper front jacket panels from the unit to access the upper chamber.
2. Locate the air shutter on the side of the fan housing (see FIG. 8-3). Turn the adjustment screw on the air shutter to open or close the shutter. Increase air shutter opening to increase air pressure. Decrease air shutter opening to decrease air pressure.
3. Adjust the air shutter until the air chamber pressure is nominally 1.25 - 1.30 inches water column for Models 497 - 747 and 1.35 - 1.45 inches water column for Models 987 - 1257. See FIG. 8-4 on installations up to 2000 feet altitude. Contact the factory for high altitude pressure settings.
4. Once the adjustment procedure is complete, reconnect the cap to the tee in the hose and check all tubing and wire connections for a snug fit. Test fire the unit. Reinstall upper panels.

### Adjustment procedure: Models 1437, 1797 and 2067

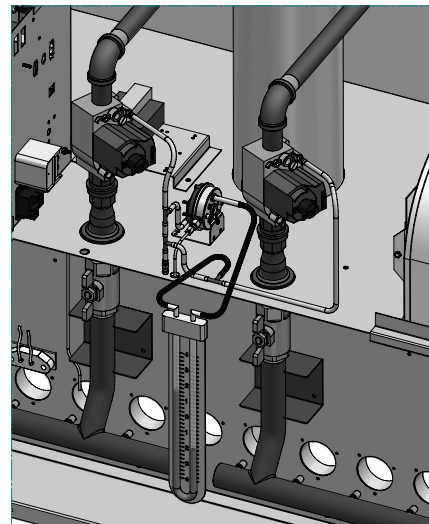
1. Remove the upper front jacket panels from the unit to access the upper chamber.
2. Slightly loosen the screws that attach the fan transition box to the metal base (see FIG. 8-5).
3. Locate the air shutter at the rear of the fan duct (see FIG. 8-6). Move the air shutter towards the rear of the unit to increase air pressure. Move the air shutter towards the front of the unit to decrease air pressure.

4. Adjust the air shutter until the air chamber pressure is nominally 1.35 - 1.45 inches water column. See FIG. 8-4 for installations up to 2000 feet altitude. Contact the factory for high altitude settings.
5. Once the adjustment procedure is complete, reattach the cap to the tee in the hose and check all tubing and wire connections for a snug fit. Test fire the unit. Reinstall upper panels.

**Figure 8-3\_Adjusting air shutter**

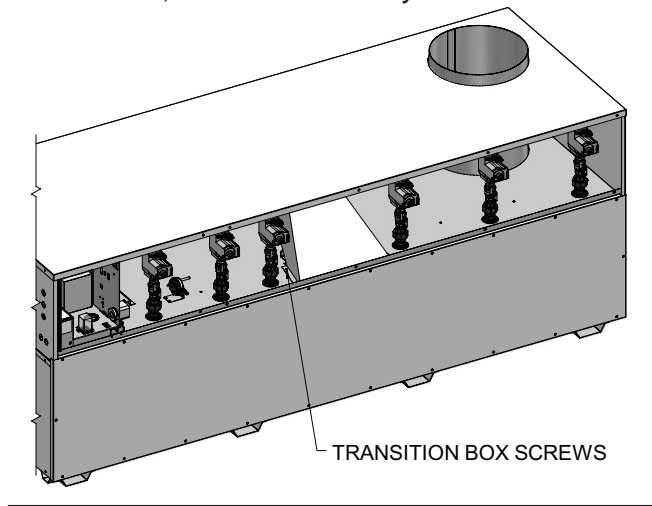


**Figure 8-4\_Combustion air adjustment with manometer to set differential pressures**

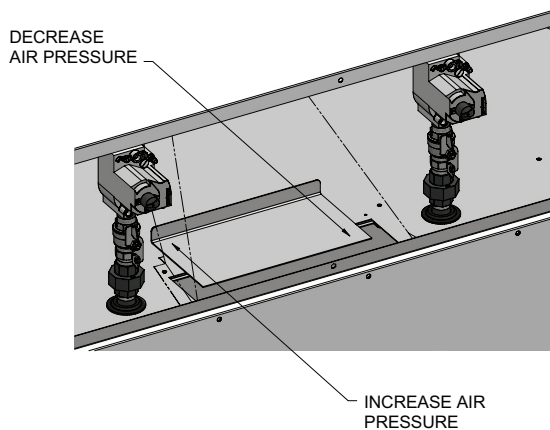


## 8 Maintenance *(continued)*

**Figure 8-5**\_Loosening the transition box screws, Models 1437, 1797 and 2067 only



**Figure 8-6**\_Adjusting the air shutter



### Servicing a hot surface igniter and ignition module

This unit uses a proven hot surface igniter module and a hot surface igniter. The hot surface igniter module is not repairable. Any modification or repairs will invalidate the warranty.

#### **⚠ WARNING**

Do not attempt to repair a faulty hot surface igniter or ignition module. Any modification or repairs may create hazardous conditions that result in property damage, personal injury, fire, explosion and/or toxic gases.

A faulty hot surface igniter or ignition module must be replaced with an identical part. A specification igniter and ignition module for this specific unit is available from your local distributor. **Do not use general purpose field replacement ignition modules or igniters.**

### Ignition system checkout

1. Turn off gas supply to unit.
2. Turn electric power on.
3. Adjust the set point on the temperature control to a setting above water temperature or to the highest safe setting.
4. The igniter will cycle on trial for ignition.
5. The ignition module will lock out and turn the alarm light on.
6. Adjust the Set Point Differential and High-Fire Offset to the desired settings.
7. Turn on gas supply.
8. Press the module reset button to reset the ignition module. This is a red button beside the ignition module or on the diagnostic panel on the header-end of the unit.
9. If ignition system fails to operate properly, repair work must be performed by a qualified service person or installer.

### Sequence of operation

#### Overview

This sequence of operation can be considered the order of events in sequential order that occur after the appliance has received a call for heat. The process begins with 120VAC power entering the appliance and ends with the appliance going into an idle state after completion of a successful call for heat.

**Note:** The following descriptions do not include remotely connected devices that may be connected to the appliance. Refer to the wiring diagram for actual point to point wiring connections that show power delivery.

1. The POWER switch is placed in the "ON" position.
2. 120VAC power is supplied to the control transformer along with L1 and F1 on the ignition module.
3. 24VAC is supplied to the electronic temperature control, the ignition module and the adjustable high limit control.
4. 24VAC is then supplied to the auxiliary limit control (if equipped).
5. If equipped, 24VAC is supplied to a low water cut-off and then to the high and low gas pressure switches.
6. 24VAC is supplied to the continuous alarm terminals A1 and A2 and then to the remote stage one terminal strip, 1C and 1NO.
7. 24VAC is supplied to the electronic temperature control.
8. The electronic temperature control then calls for heat.

## 8 Maintenance

9. 24VAC is supplied to the intermittent alarm field safety contacts, B1 and B2.
10. 24VAC is supplied to the water flow switch.
11. 24VAC is supplied to the TH terminals on the ignition module.
12. As power is applied to the TH terminals on the ignition module, 120VAC is switched from the F2 terminal to start the combustion air fan at full speed on Models 497 - 747 and at low speed on Models 987 - 2067.
13. 24VAC is supplied to the C terminal of the air pressure switch. As the low air switch makes, power is supplied to the ignition module.
14. 24VAC is then supplied to the PS terminals on the ignition module as the air pressure switch makes to prove fan operation.
15. The combustion air fan operates for the pre-purge period.
16. At the end of the pre-purge, 120VAC is applied to the hot surface igniter and the trial for ignition light.
17. The hot surface igniter proves 1800°F (982°C) ignition temperature by current draw through the ignition module.
18. The ignition module supplies voltage to the MV terminals on to the gas valve(s).
19. The first stage gas valve(s) opens and supplies gas to the orifice and burner inlet to pre-mix.
20. The gas/air mixture is forced into the burner and out of the burner ports under pressure.
21. The hot surface igniter lights the gas/air mixture and then serves as a flame sensor to prove main burner flame by rectification.
22. Burners are now firing for approximately 50% of the heater's input.
23. 24VAC is supplied from the second stage of the electronic temperature control across the 2C and 2NO terminals on the terminal strip on to a control to a relay.
24. The control relay switches the fan on Models 987 - 2067 to high speed and energizes the gas valves for the remaining 50% of burner input.
25. The remaining gas valves open and supply gas to the orifice inlet to pre-mix.
26. The gas/air mixture is forced out of the burner ports and light by carryover from the burners currently firing.
27. The heater is now firing at full rated input.

### Heat transfer process

28. Heated products of combustion pass over the heat exchanger transferring heat to the water.
29. The rate of flue product movement is controlled by "V" baffles on the heat exchanger to maximize heat transfer.
30. Flue products pass into the flue collector and are exhausted from the unit.

### End of sequence

31. Set point for the high fire on the electronic temperature control is satisfied.
32. Power to all valves is turned OFF on F9 systems and power to the high fire gas valves is turned OFF on M9 systems.
33. The water temperature continues to rise and the set point for low fire is satisfied (M9).
34. Power to the low fire gas valves is turned OFF (M9).
35. The combustion air fan runs for a post purge period and turns OFF.
36. The appliance is now in a Standby Mode waiting for the next "call for heat".

# 8 Maintenance

## Maintenance and annual startup

Table 8A\_Service and Maintenance Schedules

<b>Service technician</b> (see the following pages for instructions)		<b>Owner maintenance</b> (see the Copper-fin User's Information Manual for instructions)	
<b>ANNUAL START-UP</b>	<b>General:</b>	<b>Daily</b>	<ul style="list-style-type: none"> <li>• Check appliance area</li> <li>• Check pressure/temperature gauge</li> </ul>
	<ul style="list-style-type: none"> <li>• Address reported problems</li> <li>• Inspect interior; clean and vacuum if necessary;</li> <li>• Check for leaks (water, gas, flue, condensate)</li> <li>• Examine venting system</li> <li>• Check system water pressure/system piping/expansion tank</li> <li>• Check fill water meter</li> <li>• Test boiler water. When test indicates, clean system water with approved system restorer following manufacturer's information.</li> <li>• Check control settings</li> <li>• Check ignitor</li> <li>• Check wiring and connections</li> <li>• Check flue gas passageways</li> <li>• Flame inspection (stable, uniform)</li> <li>• Inspect and clean the burner</li> <li>• Check manifold gas pressure</li> <li>• Perform start-up checkout and performance verification per Section 6 in the Copper-fin Installation and Operation Manual.</li> </ul>	<b>Monthly</b>	<ul style="list-style-type: none"> <li>• Check vent piping</li> <li>• Check air piping</li> <li>• Check relief valve</li> <li>• Check building recirculation filter (if filter required)</li> <li>• Replace combustion air filter</li> </ul> <p><b>Note:</b> More frequent replacement may be necessary in dirty environments.</p>
	<p><b>If combustion or performance indicate need:</b></p> <ul style="list-style-type: none"> <li>• Clean heat exchanger with a stiff bristle brush</li> <li>• Remove and clean burners using water. Dry before re-assembling.</li> <li>• Clean the blower wheel with a brush and vacuum. Do not let dirt from cleaning get pulled into the blower.</li> </ul>	<b>Periodically</b>	<ul style="list-style-type: none"> <li>• Test low water cutoff (if used)</li> <li>• Reset button (low water cutoff)</li> </ul>
		<b>Every 6 months</b>	<ul style="list-style-type: none"> <li>• Check appliance piping (gas and water) for leaks</li> <li>• Operate relief valve</li> </ul>
		<b>End of season months</b>	<ul style="list-style-type: none"> <li>• Shut appliance down (unless boiler used for domestic hot water)</li> </ul>

## 9 Glossary

### Power Supply (AC120VAC/60Hz)

120VAC/60Hz/1PH power connects to black (line) and white (neutral) wires located within an electrical wiring box located on the left side of the unit. A green chassis grounding wire is also provided for connection to earth ground.

### ON/OFF Rocker Switch

The black line voltage wire runs directly to a single pole, single throw On/Off rocker switch located behind the front cover accessible by a thumb screw. Turning ON the rocker switch delivers line voltage to the low voltage transformer and ignition module.

**Note:** The On/Off switch does not provide for disconnection of power being supplied to any remotely connected devices that may be connected to the unit (i.e. pumps, louvers, power venters, etc.). As such, it may be necessary to locate and turn off power to these items before attempting to service the unit.

### Low Voltage Supply Transformer

A 120VAC to 24VAC transformer located within the control panel provides 24VAC/60Hz to many of the components located on the unit. One of its 24VAC outputs (blue) is connected to a circuit breaker and the other (yellow) is connected to chassis ground.

### 24VAC Circuit Breaker

A circuit breaker is provided on Models 987 - 2067 for protection of the low voltage supply transformer from overloads and short circuits. The breaker is located inside the unit on the lower right corner of the control panel. Power from this breaker goes to the electronic temperature controller, ignition module and various other components and/or options on the unit. When tripped, all factory-installed 24VAC components will lose their 24VAC power.

### Manual Reset High-Limit Thermostat

A manual reset high limit thermostat is provided as backup for the temperature controller. This will be an adjustable dial bulb-capillary style thermostat that will trip and require resetting should water temperature exceed its settings. When tripped, all controls remain powered, but 24VAC is prevented from being delivered to the ignition module's thermostat input.

### EMS/Sequencer/Remote Aquastat Terminals

The EMS/sequencer/remote aquastat terminals are provided for connection of the unit to an external energy management system or sequencer and are located along the top edge of the terminal strip located within the electrical wiring box. In addition to providing a means to externally stage fire the unit, these terminals also provide for remote shutdown and override by routing through dry contacts from external devices. Connection of the external dry contacts to these terminals requires the removal of one or more factory installed jumpers located on the terminal strip.

### Safety Device Terminals

The safety device terminals ensure that no power can be delivered to the ignition module unless factory/field-installed safety devices such as flow switches and gas pressure switches are closed. These safety device terminals are located below the EMS/Sequencer/Remote Aquastat terminals located within the electrical wiring box. Two types of connections are offered: Continuous terminals provide for connection of safety devices that are desired to be constantly monitored. Intermittent terminals are provided for devices that are only monitored during a "call for heat" cycle. Connection to either of these terminals requires the removal of a factory-installed jumper located on the terminal strip.

### Electronic Temperature Controller (Operator)

A 2-stage electronic temperature controller is provided on the unit and it serves to maintain a user selectable temperature set point. Ultimately, the temperature controller delivers 24VAC to the ignition module and pressure switch when it senses heat mode is desired. It also activates the pump relay. If more heat is needed, it activates the high fire stage.

### Ignition Module (Controlled by Electronic Temperature Controller)

One ignition module is provided on the unit. Upon sensing the 24VAC delivered to it by the electronic temperature controller, the ignition module checks for a shorted pressure switch and then, provided the air switch isn't shorted, supplies 120VAC to its blower output relay and waits for a pressure switch signal.

### Two Speed Blower (Controlled by Ignition Module and Relay Board)

A single 2-speed blower on Models 987 - 2067 (single 1-speed blower on Models 497 - 747) provide combustion air to the unit. The blower is provided with a high and low speed tap. The blower operates in tandem with the ignition module when a call for heat signal is received. Depending upon the number of stages in operation, the blower's speed may increase or decrease accordingly.

### Pressure Switch (Activated by Blower Turning On)

One pressure switch is provided to monitor the blower On/Off operation. Upon a call for heat, 24VAC is delivered to the pressure switch. If the blower generates adequate air pressure, the pressure switch closes to deliver 24VAC to the ignition module pressure switch monitoring input terminal.

### Prepurge (Ignition Module Function)

## 9 Glossary

Once the ignition module sees a 24VAC input from the pressure switch, it runs the blower in order to purge the combustion chamber of any unburned fuel/air mixture.

### **Trial for Ignition**

#### **(Ignition Module Function)**

Once the ignition module has completed its prepurge period, it turns on the hot surface igniter. Once the hot surface igniter's current draw reaches a proper level, the ignition module begins a trial for ignition period to allow time for the igniter to reach the ignition temperature necessary to ignite the fuel/air mixture.

### **Igniter**

#### **(Controlled by Ignition Module)**

One igniter is provided in order to ignite the fuel/air mixture and its on/off operation is controlled by the ignition module.

### **Hi-Lo Fire Relay**

The relay serves as means to switch from low fire to high fire. On Models 987 - 2067, in addition to switching between high fire to low fire, the relay also changes the fan speed from high for high fire to low for low fire.

### **Ignition**

#### **(Ignition Module Function)**

Once the trial for ignition period has been completed, the ignition module sends 24VAC to the gas valves on the low fire stage (Stage 1). Gas valves should open and allow gas to flow to the burners in Stage 1 being energized. The fuel/air mixture should ignite from the hot surface igniter. Once this voltage has been sent to the valves, the hot surface igniter is turned off. The ignition module then monitors the status of the flame and will either allow ignition to continue or shut down the gas valves should flame not be proven and proceed to a Flame Failure condition. If flame was proven briefly during the ignition period, the module may not proceed to Flame Failure, but rather post-purge and then go into another trial for ignition.

### **Heat Transfer Process**

#### **(Gas Valves, Burner, and Heat Exchanger)**

Once flame has been proven, the ignition module will hold the gas valves open as long as there is proof of flame and a call for heat is present. If the low fire stage cannot provide enough heat to raise the system temperature, the electronic temperature controller turns on the high fire stage. The high fire stage will operate until the system water temperature shows a gain that can be handled by low fire operation. The high fire stage shuts off at this point. When the low-fire stage alone produces more heat than is required, the electronic temperature controller turns off the call for heat.

### **Post-Purge**

#### **(Ignition Module Function)**

When 24VAC is removed from the ignition module's thermostat input, the module turns off the gas valves and maintains the blower in order to allow the combustion chamber to be purged of all combustion by-products.

### **Pump Delay**

#### **(Electronic Thermostat Function)**

When the electronic thermostat removes 24VAC from the ignition module, it continues to hold the pump relay on in order to get the remaining heat out of the combustion chamber. The pump then turns off to prevent the heat in the water from going back into the combustion chamber and up the flue.

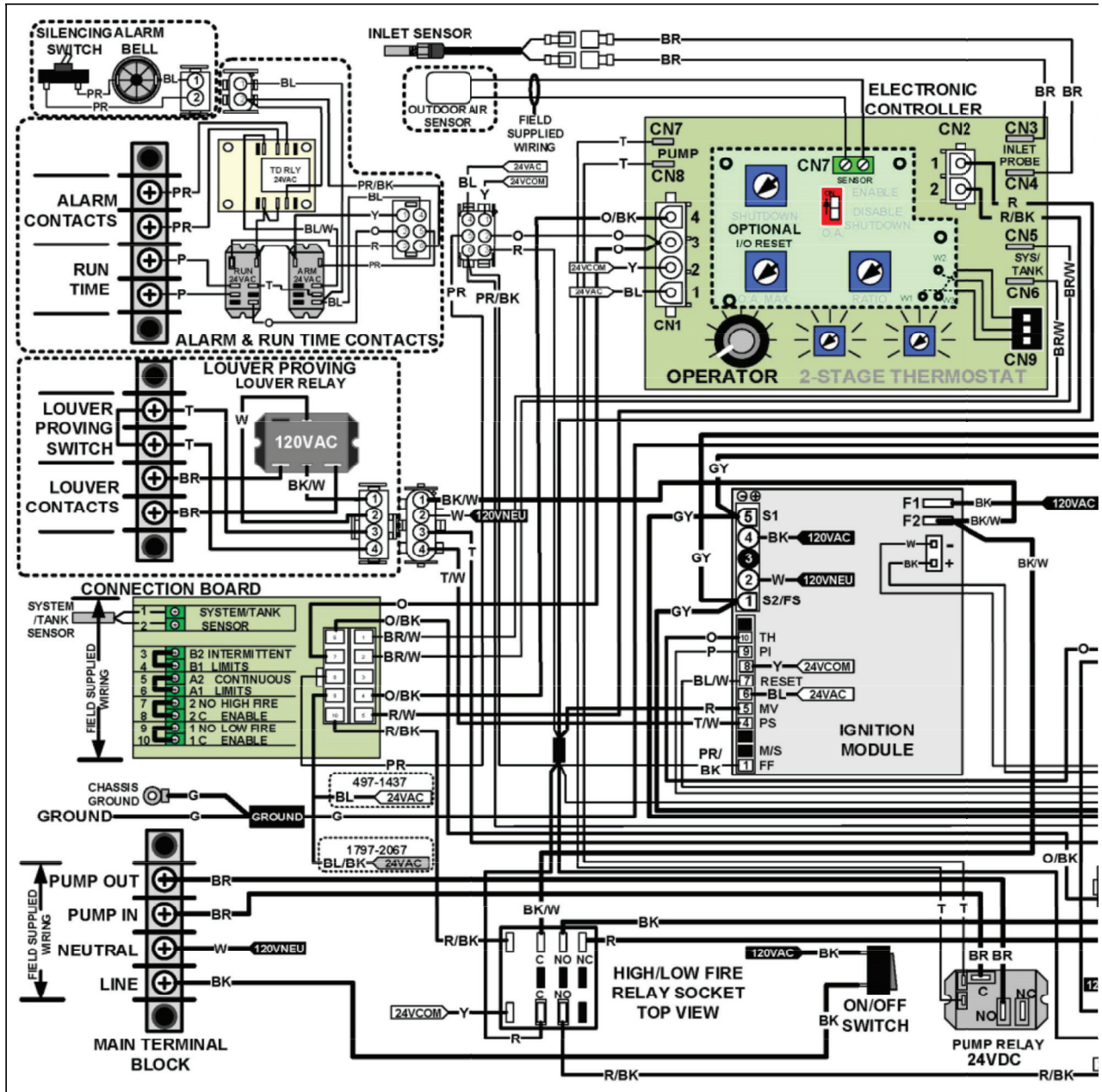
### **Idle**

#### **(Electronic Thermostat Function)**

After completion of the post-purge cycle, the unit will go into an idle state whereby the electronic thermostat continuously monitors the water temperature until the water temperature drops to levels that require additional heat.

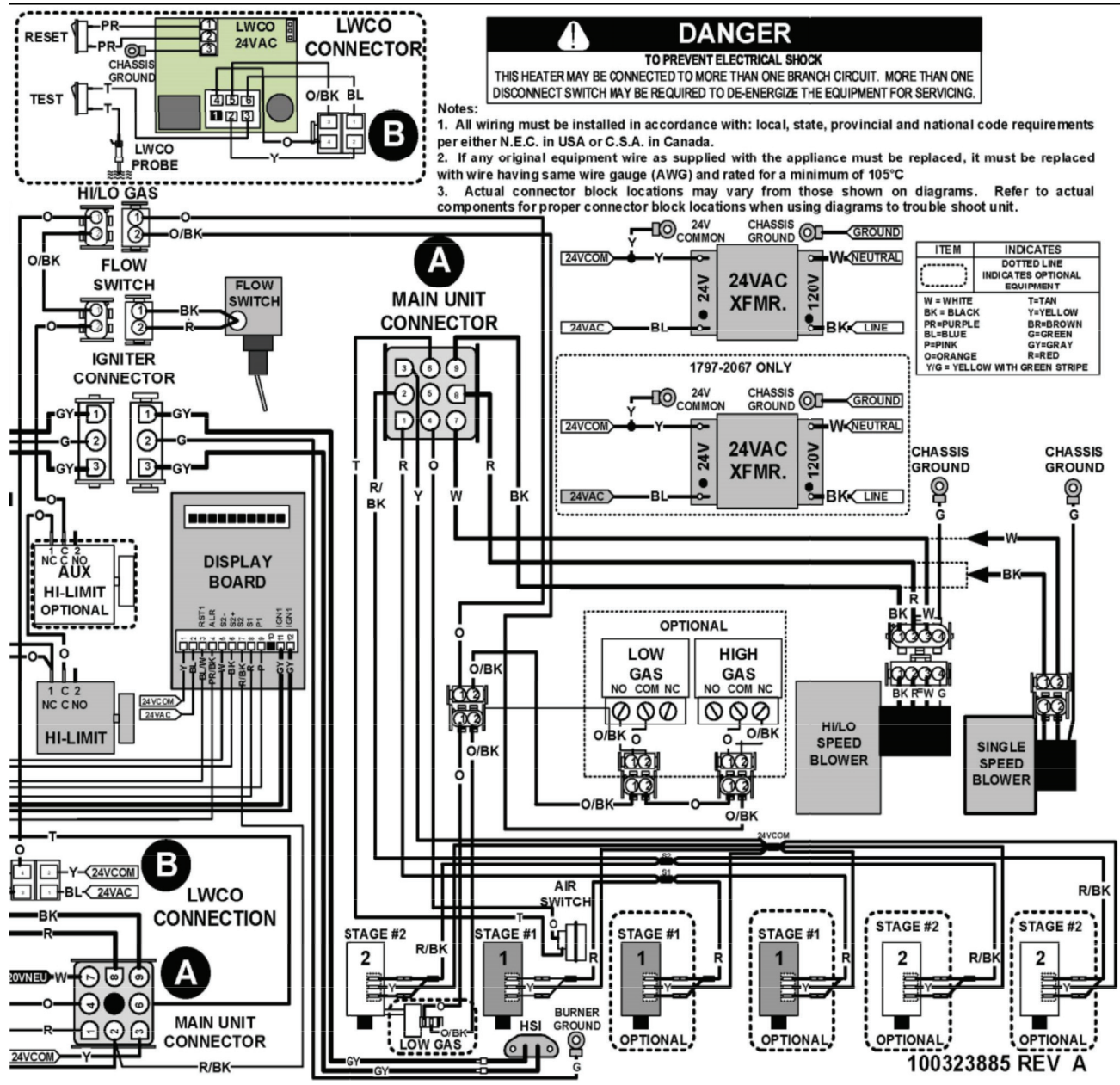
# 10 Diagrams

## Ladder diagram



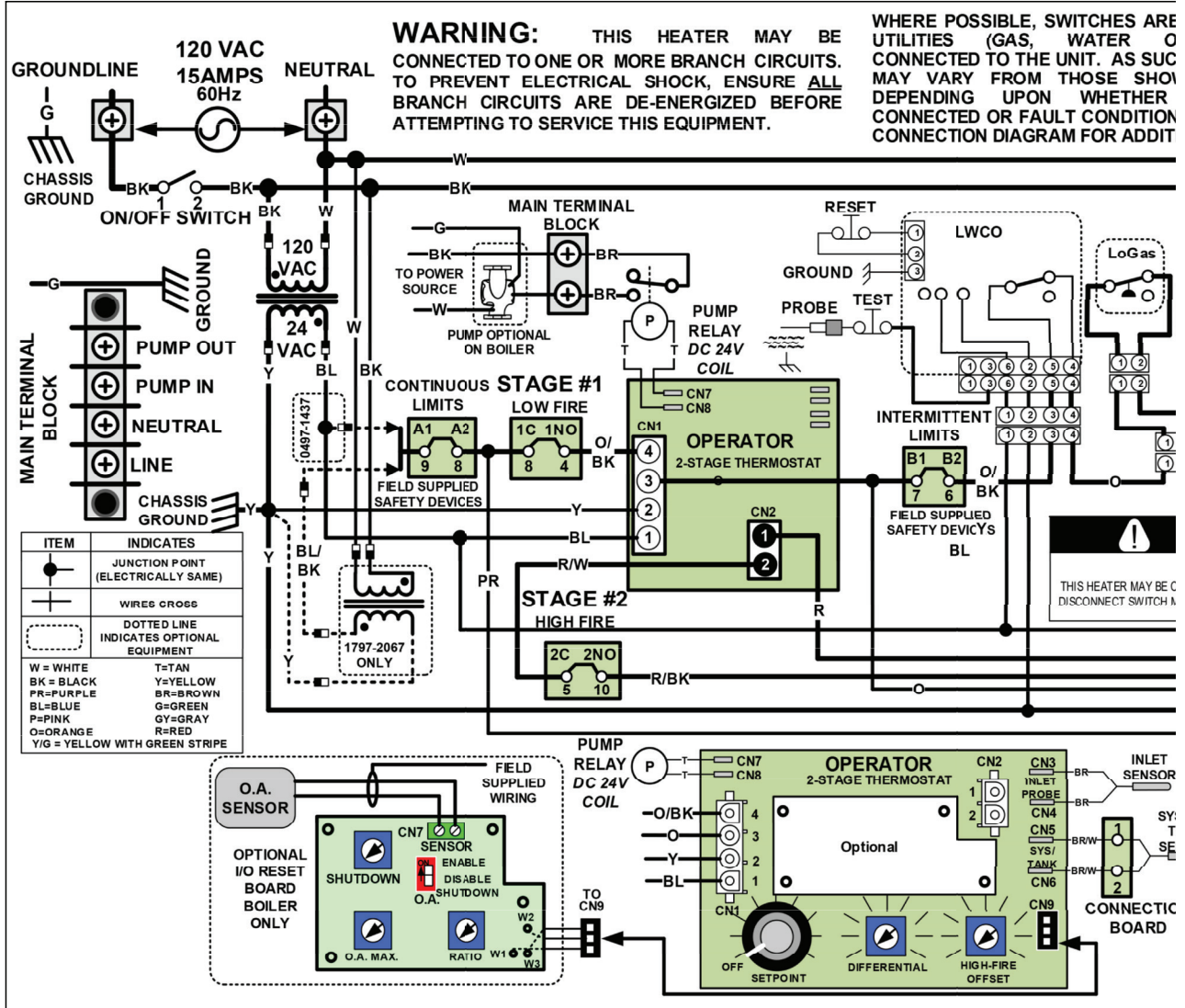
# 10 Diagrams *(continued)*

## Ladder diagram *(continued)*



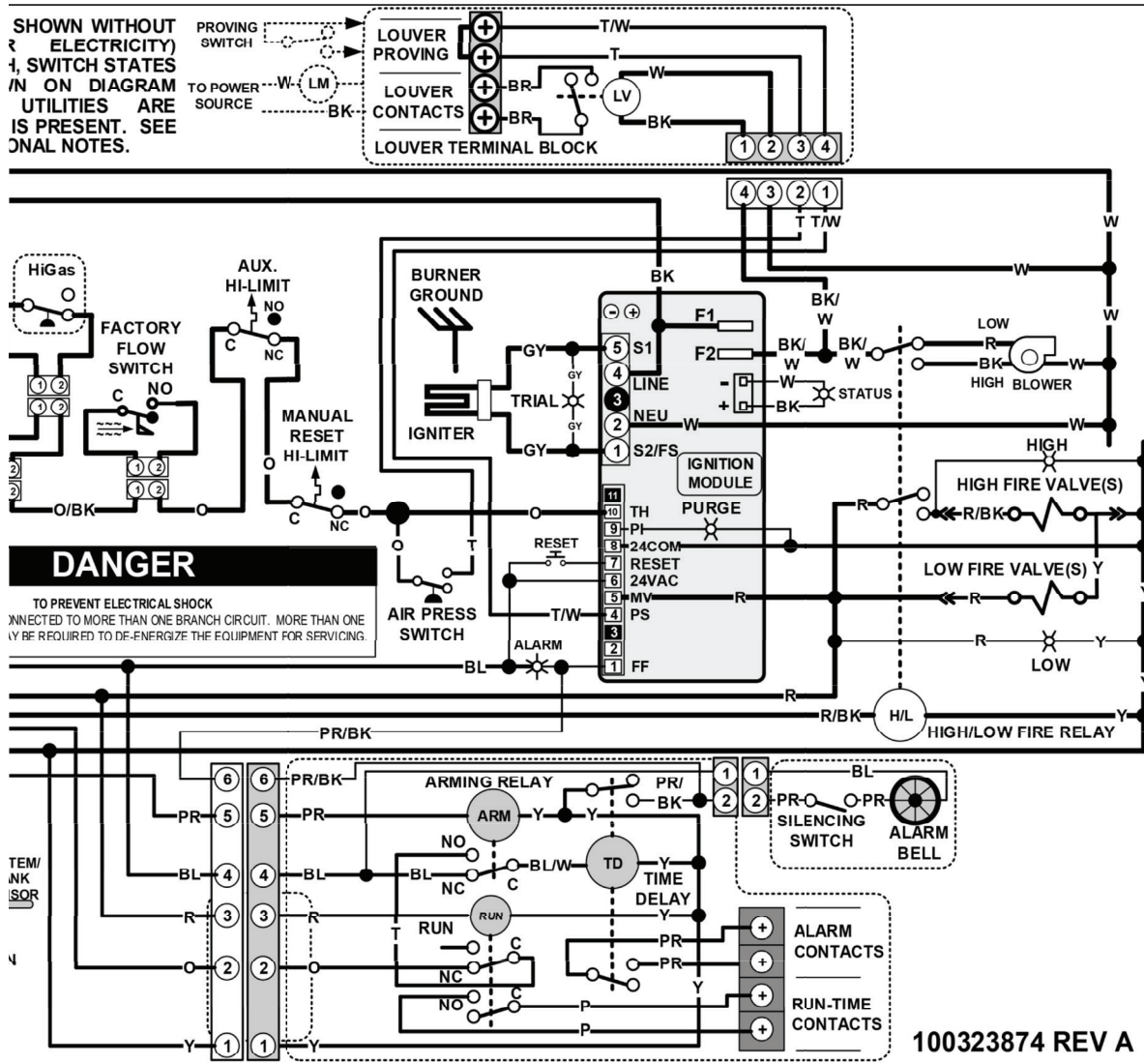
# 10 Diagrams

## Connection diagram



# 10 Diagrams *(continued)*

## Connection diagram *(continued)*



**Revision Notes:** Revision A (ECO #C07390) initial release.

Revision B (ECO C09691) reflects the update of AHRI and ASME logos on pages 8 and 9.

Revision C (ECO C12077) reflects the update of ignition timing information on pages 40, 43, 61 and 63 as well as the update of heat exchanger information on page 54.

Revision D (ECO C12972) reflects the addition of the CSA Low Lead Content logo.

Revision E (ECO C13163) reflects the addition of the Line Voltage Connections section on page 38 per ECR R06420.

Revision F (ECO C16918) reflects the update of water volume in the ratings tables on pages 8 and 9 and the correction of Table 3D on page 24 for gas pipe sizing (R07763).

Revision G (PCP# 3000002766 / CN# 500003005) reflects a correction to images 7-1 through 7-4 on pages 49 through 52. SAP Numbers have been updated.

Revision H (PCP# 3000006579 / CN# 500006677) reflects the addition of new venting category information on pages 20 through 21.

Revision J (PCP #3000021634 / CN #500011858) reflects changes made to water chemistry information on pages 4, 29, 33-37, 48-54, 56-57, and 60.

Revision K (PCP #3000030852 / CN #500020656) reflects an update to all piping diagrams and the addition of the notice on page 56.

Revision L (PCP #3000033919 / CN #500022621) reflects the input rates and output rates are revised to match AHRI rounding and comply with Energy Star turndown rate requirements.

Revision M (PCP #3000037705 / CN #500025906) reflects an update to the Figure 5-10, ladder diagram, and connection diagram

Revision N (PCP #3000038599 / CN #500026731) reflects an update to the venting warnings on pages 16 and 22 as well as the addition of Figure 2-5.

Revision P (PCP #3000042140 / CN #500030042) reflects an update to the optional outdoor kit information on pages 22-23.

Revision R (PCP #3000043534 / CN #500031265) reflects an update to FIG. 2-7 and the addition of Table 8A.

Revision T (PCP #3000045219 / CN #500032730) reflects an update to FIG. 2-7 and Table 2B.

Revision U (PCP #3000051769 / CN #500038677) reflects changes to table 2C on page 23.

Revision V (PCP #3000053388 / CN #500040014) reflects changes to the AHRI Rating table on page 8, Table 4B, boiler operation on page 50, and the addition of Table 6B.

Revision W (PCP #3000057694 / CN #500043851) reflects the addition of a carbon monoxide warning on page 3.

Revision X (PCP #3000060820 / CN #500046810) reflects the addition of a dielectric notice on page 51.

Revision Y (PCP #3000063455 / CN #500049242) reflects model and temperature updates to page 50.