

# Copper-Fin<sup>®</sup>

**User's Information Manual**  
**Models: 90,000 - 500,000 Btu/hr**

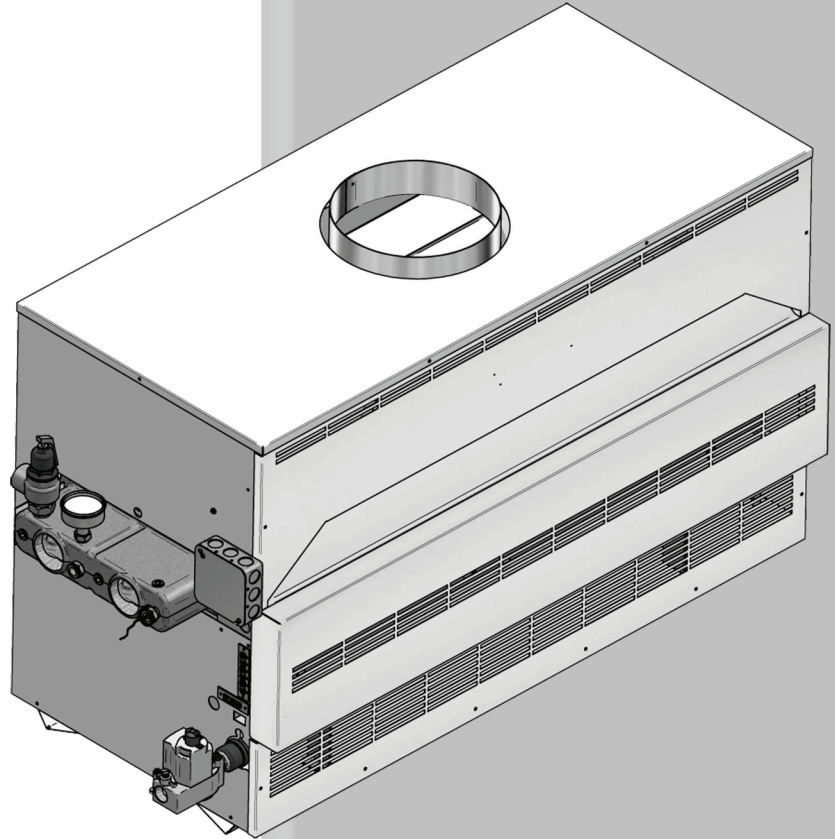

**Lochinvar<sup>®</sup>**  
High Efficiency Water Heaters, Boilers and Pool Heaters

**⚠ WARNING:**

If the information in this manual is not followed exactly, a fire or explosion may result causing property damage, personal injury or loss of life.

This appliance **MUST NOT** be installed in any location where gasoline or flammable vapors are likely to be present.

**WHAT TO DO IF YOU SMELL GAS**

- Do not try to light any appliance.
- Do not touch any electric switch; do not use any phone in your building.
- Immediately call your gas supplier from a near by phone. Follow the gas supplier's instructions.
- If you cannot reach your gas supplier, call the fire department.
- Installation and service must be performed by a qualified installer, service agency, or the gas supplier.

**Save this manual for future reference.**

# Contents

<b>HAZARD DEFINITIONS</b> .....	2	<b>2. OPERATING INSTRUCTIONS</b> .....	8-11
<b>PLEASE READ BEFORE PROCEEDING</b> .....	3-4	Revision Notes .....	Back Cover
<b>1. MAINTENANCE SCHEDULE</b> .....	5		
Maintenance Procedures .....	6		
Appliance Must Be Serviced and Maintained.....	6		
Check Appliance Area .....	6		
Check Pressure Temperature Gauge.....	6		
Check Vent Piping .....	6		
Check Air Piping .....	6		
Check Relief Valve .....	6		
Test Low Water Cutoff (if installed) .....	6		
Reset Button (low water cutoff) .....	6		
Check Appliance Piping (gas and water) .....	7		
Operate Relief Valve .....	7		
Shut Appliance Down .....	7		

---

## Hazard definitions

The following defined terms are used throughout this manual to bring attention to the presence of hazards of various risk levels or to important information concerning the life of the product.

### **DANGER**

DANGER indicates an imminently hazardous situation which, if not avoided, will result in death or serious injury.

### **WARNING**

WARNING indicates a potentially hazardous situation which, if not avoided, could result in death or serious injury.

### **CAUTION**

CAUTION indicates a potentially hazardous situation which, if not avoided, may result in minor or moderate injury.

### **CAUTION**

CAUTION used without the safety alert symbol indicates a potentially hazardous situation which, if not avoided, may result in property damage.

### **NOTICE**

NOTICE indicates special instructions on installation, operation, or maintenance that are important but not related to personal injury or property damage.

## Please read before proceeding

### NOTICE

This is a gas appliance and should be installed by a licensed electrician and/or certified gas supplier. Service must be performed by a qualified service installer, service agency or the gas supplier.

### ⚠ WARNING

If the information in these instructions is not followed exactly, a fire or explosion may result causing property damage, personal injury, or death.

This appliance **MUST NOT** be installed in any location where gasoline or flammable vapors are likely to be present, unless the installation is such to eliminate the probable ignition of gasoline or flammable vapors.

### What to do if you smell gas –

- Do not try to light any appliance.
- Do not touch any electric switch; do not use any phone in your building.
- Immediately call your gas supplier from a near by phone. Follow the gas supplier's instructions.
- If you cannot reach your gas supplier, call the fire department.

Installation and service must be performed by a qualified installer, service agency, or the gas supplier.

### Warranty –

Installation and service must be performed by a qualified service installer, service agency or the gas supplier.

Factory warranty (shipped with unit) does not apply to units improperly installed or improperly operated.

Experience has shown that improper installation or system design, rather than faulty equipment, is the cause of most operating problems.

1. Excessive water hardness causing a lime/scale build-up in the copper tube is not the fault of the equipment and is not covered under the manufacturer's warranty (Refer to the *Water Treatment and Water Chemistry* section in the Copper-Fin Installation and Service manual).
2. Excessive pitting and erosion on the inside of the copper tube may be caused by too much water velocity through the tubes and is not covered by the manufacturer's warranty (Refer to *Boiler Flow Rates and Temperature Rise for flow requirements* section in the Copper-Fin Installation and Service manual).

### ⚠ WARNING

Improper installation, adjustment, alteration, service or maintenance can cause injury or property damage. Refer to this manual for assistance or additional information, consult a qualified installer, service agency or the gas supplier.

### Checking equipment –

Upon receiving equipment, check for signs of shipping damage. Pay particular attention to parts accompanying the appliances which may show signs of being hit or otherwise being mishandled. Verify total number of pieces shown on the packing slip with those actually received. In case there is damage or a shortage, immediately notify the carrier.

**Do not use this appliance if any part has been under water. The possible damage to a flooded appliance can be extensive and present numerous safety hazards. Any appliance that has been under water must be replaced.**

### ⚠ Owner warning –

**NOTE:** Retain this manual for future reference.

The information contained in this manual is intended for use by qualified professional installers, service technicians, or gas suppliers. **Consult your local expert for proper installation or service procedures.**

### IMPORTANT

Consult and follow all local Building and Fire Regulations and other Safety Codes that apply to this installation. Consult your local gas utility company to authorize and inspect all gas and flue connections.

Your conventionally vented gas appliance must have a supply of fresh air circulating around it during burner operation for proper gas combustion and proper venting.

### ⚠ WARNING

Should overheating occur or the gas supply fail to shut off, do not turn off or disconnect the electrical supply to the pump. Instead, shut off the gas supply at a location external to the appliance.

## Please read before proceeding

**⚠ WARNING**

To minimize the possibility of serious personal injury, fire, or damage to your appliance, never violate the following safety rules:

1. Boilers and water heaters are heat producing appliances. To avoid damage or injury, do not store materials against the appliance or the vent-air intake system. Use proper care to avoid unnecessary contact (especially children) with the appliance and vent-air intake components.
2. Never cover your appliance, lean anything against it, store trash or debris near it, stand on it or in any way block the flow of fresh air to your appliance.
3. UNDER NO CIRCUMSTANCES must flammable materials such as gasoline or paint thinner be used or stored in the vicinity of this appliance, vent-air intake system or any location from which fumes could reach the appliance or vent-air intake system.

### Codes –

The equipment shall be installed in accordance with those installation regulations in force in the local area where the installation is to be made. These regulations shall be carefully followed in all cases. Authorities having jurisdiction shall be consulted before installations are made. In the absence of such requirements, the installation shall conform to the latest edition of the National Fuel Gas Code, ANSI Z223.1. Where required by the authority having jurisdiction, the installation must conform to American Society of Mechanical Engineers Safety Code for Controls and Safety Devices for Automatically Fired Boilers, ASME CSD-1. All boilers conform to the latest edition of the ASME Boiler and Pressure Vessel Code, Section IV. Where required by the authority having jurisdiction, the installation must comply with the Canadian Association Code, CAN/CGA- B149.1 and/or local codes.

This appliance meets the safe lighting performance criteria with the gas manifold and control assembly provided as specified in the ANSI standards for gas-fired appliances, ANSI Z21.13 and ANSI Z21.10.3.

# 1 Maintenance schedule

<b>Service technician</b> (Refer to the Copper-Fin Installation and Service manual)		<b>Owner maintenance</b>	
<b>Annual Startup</b>	<p><b>General:</b></p> <ul style="list-style-type: none"> <li>• Address reported problems</li> <li>• Inspect interior; clean and vacuum if necessary;</li> <li>• Check for leaks (water, gas, flue)</li> <li>• Examine venting system</li> <li>• Check system water pressure/ system piping/expansion tank</li> <li>• Check fill water meter</li> <li>• Test boiler water. When test indicates, clean system water with approved system restorer following manufacturer's information.</li> <li>• Check control settings</li> <li>• Check wiring connections</li> <li>• Flame inspection (stable, uniform)</li> <li>• Check flue gas passageways</li> <li>• Inspect and clean the burner</li> <li>• Perform start-up check-out and performance verification. Refer to the Startup section in the Copper-Fin Installation and Service manual</li> </ul> <p><b>If combustion or performance indicate need:</b></p> <ul style="list-style-type: none"> <li>• Clean heat exchanger</li> <li>• Remove and wash burner</li> </ul>	<p><b>Daily</b></p> <ul style="list-style-type: none"> <li>• Check appliance area</li> <li>• Check pressure/temperature gauge</li> </ul>	
		<p><b>Monthly</b></p> <ul style="list-style-type: none"> <li>• Check vent piping</li> <li>• Check relief valve</li> <li>• Remove debris from Y-strainer per manufacturer's instructions</li> <li>• Check building recirculation filter (if filter required)</li> </ul>	
		<p><b>Periodically</b></p> <ul style="list-style-type: none"> <li>• Test low water cutoff (if used)</li> <li>• Reset button (low water cutoff)</li> </ul>	
		<p><b>Every 6 months</b></p> <ul style="list-style-type: none"> <li>• Check appliance piping (gas and water) for leaks</li> <li>• Operate relief valve</li> </ul>	
		<p><b>End of season months</b></p> <ul style="list-style-type: none"> <li>• Shut appliance down (unless boiler used for domestic hot water)</li> </ul>	

# 1 Maintenance schedule

## Maintenance procedures

### Appliance must be serviced and maintained

#### ⚠ WARNING

Follow the service and maintenance procedures given throughout this manual and in component literature shipped with the appliance. Failure to perform the service and maintenance could result in damage to the appliance or system. Failure to follow the directions in this manual and component literature could result in severe personal injury, death, or substantial property damage.

#### ⚠ WARNING

The appliance must be inspected and started annually at the beginning of the heating season by a qualified service technician. In addition, the maintenance and care of the appliance designated on page 5 of this manual and explained on pages 6 through 7 must be performed to assure maximum appliance efficiency and reliability. Failure to service and maintain the appliance and system could result in equipment failure, causing possible severe personal injury, death, or substantial property damage.

#### NOTICE

The following information provides detailed instructions for completing the maintenance items listed in the maintenance schedule on page 5. In addition to this maintenance, the appliance must be serviced and started up at the beginning of each heating season by a qualified service technician.

### Check appliance area

#### ⚠ WARNING

To prevent potential of severe personal injury, death, or substantial property damage, eliminate all materials discussed below from the appliance vicinity and the vicinity of the appliance combustion air inlet. If contaminants are found:

Remove products immediately from the area. If they have been there for an extended period, call a qualified service technician to inspect the appliance for possible damage from acid corrosion.

If products cannot be removed, immediately call a qualified service technician to re-pipe vent and air piping and locate vent termination/air intake away from contaminated areas.

1. Combustible/flammable materials -- Do not store combustible materials, gasoline or any other flammable vapors or liquids near the appliance. Remove immediately if found.
2. Air contaminants -- Products containing chlorine or fluorine, if allowed to contaminate the appliance intake air, will cause acidic condensate in the boiler. This will cause significant damage to the boiler if allowed to continue.

#### ⚠ WARNING

Failure to inspect the vent system as noted above and have it repaired by a qualified service technician can result in vent system failure, causing severe personal injury or death.

### Check vent piping

1. Visually inspect the vent piping to be sure it is unobstructed. Inspect the entire length of the vent piping to ensure piping is intact and all joints are properly sealed.
2. Call your qualified service technician if you notice any problems.

### Check relief valve

1. Inspect the appliance relief valve and the relief valve discharge pipe for signs of weeping or leakage.
2. If the relief valve often weeps, the expansion tank may not be working properly. Immediately contact your qualified service technician to inspect the appliance and system.

### Test low water cutoff (if installed)

1. If the system is equipped with a low water cutoff, test the low water cutoff periodically during the heating season, following the low water cutoff manufacturer's instructions.

### Reset button (low water cutoff)

1. Testing the low water cutoff shuts the unit off. Press the RESET button on the low water cutoff to turn the unit back on.

# 1 Maintenance schedule *(continued)*

## Check appliance piping (gas and water)

1. Access the appliance and perform a gas leak inspection per steps 1 through 7 of the Operating Instructions on page 8. If gas odor or leak is detected, immediately shut down the boiler and call a qualified service technician.
2. Visually inspect for leaks around water piping. Also inspect the circulators, relief valve, and fittings. Immediately call a qualified service technician to repair any leaks.

**⚠ WARNING** Have leaks fixed at once by a qualified service technician. Failure to comply could result in severe personal injury, death, or substantial property damage.

## Operate relief valve

1. Before proceeding, verify that the relief valve outlet has been piped to a safe place of discharge, avoiding any possibility of scalding from hot water.

**⚠ WARNING** To avoid water damage or scalding due to valve operation, a metal discharge line must be connected to the relief valve outlet and run to a safe place of disposal. This discharge line must be installed by a qualified heating installer or service technician in accordance with the instructions in the Copper-Fin Installation and Service Manual. The discharge line must be terminated so as to eliminate possibility of severe burns or property damage should the valve discharge.

2. Read the boiler pressure/temperature gauge to make sure the system is pressurized. Lift the relief valve top lever slightly, allowing water to relieve through the valve and discharge piping.
3. If water flows freely, release the lever and allow the valve to seat. Watch the end of the relief valve discharge pipe to ensure that the valve does not weep after the line has had time to drain. If the valve weeps, lift the seat again to attempt to clean the valve seat. If the valve continues to weep afterwards, contact your qualified service technician to inspect the valve and system.
4. If water does not flow from the valve when you lift the lever completely, the valve or discharge line may be blocked. Immediately shut down the appliance. Call your qualified service technician to inspect the appliance and system.

## Shut appliance down (unless boiler is used for Domestic Water)

1. Follow "To Turn Off Gas to Appliance" on page 9 of this manual.
2. Do not drain the system unless exposure to freezing temperatures will occur.
3. Do not drain the system if it is filled with an antifreeze solution.
4. DO NOT shut down boilers used for domestic water heating, they must operate year-round.

## 2 Operating instructions

### Lighting Instructions for Standing Pilot Models (F1) Models 90,000 through 270,000 Btu/hr Input

#### FOR YOUR SAFETY READ BEFORE OPERATING

##### ⚠ WARNING

If you do not follow these instructions exactly, a fire or explosion may result causing property damage, personal injury or loss of life.

- A. This appliance has a pilot which must be ignited by hand. When lighting the pilot, follow these instructions exactly.
- B. **BEFORE OPERATING**, smell around the appliance area for gas. Be sure to smell next to the floor because some gas is heavier than air and will settle to the floor.

#### WHAT TO DO IF YOU SMELL GAS

Do not try to light any appliance.

Do not touch any electric switch; do not use any phone in your building.

Immediately call your gas supplier from a near by phone. Follow the gas supplier's instructions.

If you cannot reach your gas supplier, call the fire department.

- C. Use only your hand to push in or turn the gas control knob. Never use tools. If the knob will not turn by hand, don't try to repair it, call a qualified service technician. Force or attempted repair may result in a fire or explosion.
- D. Do not use this appliance if any part has been under water. Immediately call a qualified service technician to inspect the appliance. The possible damage to a flooded appliance can be extensive and present numerous safety hazards. Any appliance that has been under water must be replaced.

### Lighting Instructions

1. STOP! Read the safety information first.
2. Remove the control panel door.
3. Set the thermostat to the lowest setting (OFF).
4. Turn off all electrical power to the appliance.
5. Turn the gas control knob on the gas valve clockwise to the "OFF" position.

**Figure 2-1\_Gas Valve 90,000 - 270,000 Btu/hr Models**

F-1 GAS VALVE  
90,000 -270,000 BTU MODELS

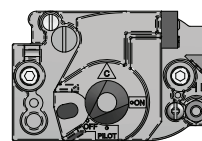

TOP

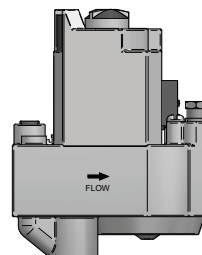

SIDE

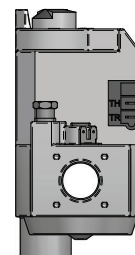

OUTLET

6. Wait five (5) minutes to clear out any gas, then smell for gas, including near the floor. If you smell gas, STOP! Follow the steps in the "What To Do If You Smell Gas" section in the safety information. If you do not smell gas go on to the next step.
7. Remove the lower panel door to gain access to the pilot.
8. Find the pilot - Follow the metal tube from the gas valve to the pilot. The pilot is located on the right side of the burner approximately centered in the burner tray.

## 2 Operating instructions *(continued)*

**Figure 2-2\_Pilot Location**

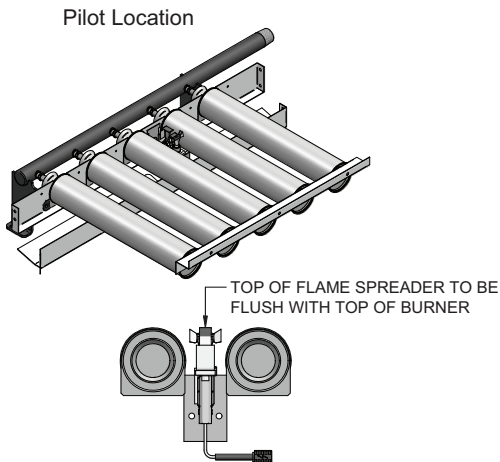

- Turn the control knob on the gas valve counterclockwise to the "PILOT" position.

**Figure 2-3\_Lighting Wand**

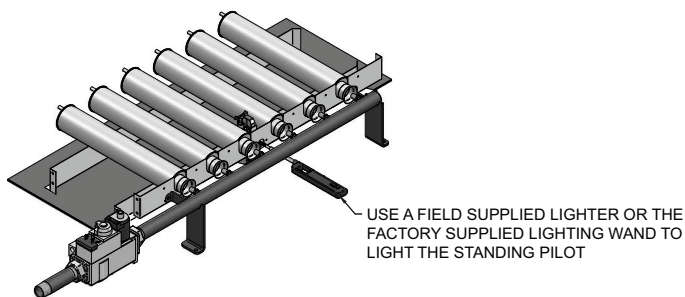

### NOTICE

The information package shipped with the appliance contains a wire lighting wand. The loop end of the wand will hold a match. The wand extends your reach to the pilot and makes lighting the pilot easier (see FIG. 2-3).

- Use the loop end of the wire lighting wand, shipped with the instruction package, to hold the match and reach the pilot. An access slot is provided in the lower front jacket panel, beside the burner, to insert the lighting wand and match to the pilot. Lift the pilot cover (FIG. 2-3) to access the pilot. Push down and hold in the red button on the gas valve. This should start gas flow to the pilot. Continue to hold the red button in for about one (1) minute after the pilot is lit. Release the button and it will pop back up. The pilot should remain lit. If the pilot goes out, repeat steps 5 through 10.

If the red button does not pop up when released, stop and immediately call your gas supplier.

If the pilot will not stay lit after several tries, turn the gas control to "OFF" and call your service technician or gas supplier.

- Turn the gas control knob on the gas valve counterclockwise to the "ON" position.
- Turn on all electric power to the appliance.
- Re-install the lower panel door.
- Set the thermostat to the desired setting.
- Re-install the control panel door.

### TO TURN OFF GAS TO APPLIANCE

- Set the thermostat to the OFF position.
- Turn off all electric power to the appliance if service is to be performed.
- Turn the gas control knob on the gas valve clockwise to the "OFF" position. Do not force.

### ⚠ WARNING

Should overheating occur or the gas fail to shut off, turn off the external manual gas valve to the appliance.

## 2 Operating instructions

### Safety Shutoff Test For Standing Pilot Ignition System

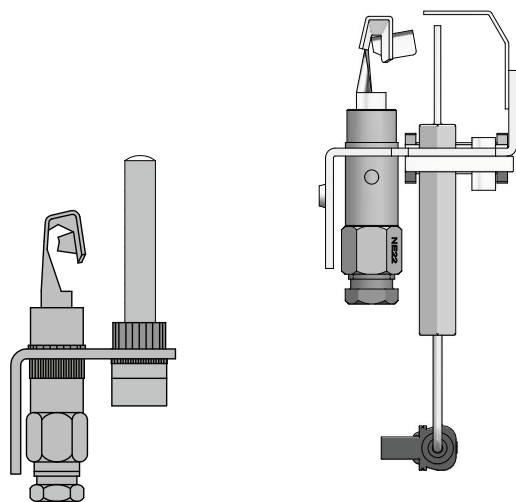

PILOT WITH THERMOCOUPLE

PILOT WITH SPARK IGNITION

**Figure 2-4\_Pilot with Thermocouple and Spark Ignition**

1. With the main burners on and firing, unscrew the thermocouple connection from the gas valve (FIG. 2-4) and remove from the fitting.
2. The main gas valve should extinguish the burners immediately after removal of the thermocouple.
3. If burners do not extinguish, immediately follow steps in "To Turn Off Gas To Appliance".
4. Immediately call a qualified serviceman or installer to repair an ignition system that fails to operate properly and shut down the burners.
5. After successful completion of test, turn the control knob on the gas valve clockwise to the "OFF" position. Do not force.
6. Carefully reconnect the thermocouple to the gas valve.
7. Follow the Lighting Instructions to relight the pilot and establish normal operation.

### Lighting Instructions for Spark Ignition Pilot Models (F9/M9) Models 90,000 through 500,000 Btu/hr Input

#### FOR YOUR SAFETY READ BEFORE OPERATING

##### ⚠ WARNING

If you do not follow these instructions exactly, a fire or explosion may result causing property damage, personal injury or loss of life.

- A. This appliance is equipped with an ignition device which automatically lights the pilot. Do not try to light the pilot by hand.
- B. **BEFORE OPERATING**, smell around the appliance area for gas. Be sure to smell next to the floor because some gas is heavier than air and will settle to the floor.

#### WHAT TO DO IF YOU SMELL GAS

Do not try to light any appliance.

Do not touch any electric switch; do not use any phone in your building.

Immediately call your gas supplier from a nearby phone. Follow the gas supplier's instructions.

If you cannot reach your gas supplier, call the fire department.

- C. Use only your hand to turn the gas control knob. Never use tools. If the knob will not turn by hand, don't try to repair it, call a qualified service technician. Force or attempted repair may result in a fire or explosion.
- D. Do not use this appliance if any part has been under water. Immediately call a qualified service technician to inspect the appliance. The possible damage to a flooded appliance can be extensive and present numerous safety hazards. Any appliance that has been under water must be replaced.

## 2 Operating instructions

### Operating Instructions

1. STOP! Read the safety information first.
2. Remove the control panel door.
3. Set the thermostat to the lowest setting (OFF).
4. Turn off all electrical power to the appliance.
5. This appliance is equipped with an ignition device which automatically lights the pilot. DO NOT try to light the pilot by hand.
- 6a. 90,000 - 135,000 and 399,999 - 500,000 Btu/hr models, rotate the gas control knob on the gas valve clockwise to the "OFF" position.
- 6b. 180,000 - 360,000 Btu/hr models, rotate the gas control knob on the gas valve clockwise to the line on the collar around the knob. Depress the knob and continue rotation to the "OFF" position.
7. Wait five (5) minutes to clear out any gas, then smell for gas, including near the floor. If you smell gas, STOP! Follow the steps in the "What To Do If You Smell Gas" section in the safety information, this page. If you do not smell gas go on to the next step.
- 8a. 90,000 - 135,000 and 399,999 - 500,000 Btu/hr models, rotate the gas control knob on the gas valve counterclockwise to the "ON" position.
- 8b. 180,000 - 360,000 Btu/hr models, rotate the gas control knob on the gas valve counterclockwise to the line on the collar around the knob. Allow the knob to "pop" up, and continue rotation to the "ON" position.
9. Turn on all electric power to the appliance.
10. Set the thermostat to the desired setting.
11. Re-install the control panel door.
12. If the appliance will not operate, follow the instructions "To Turn Off Gas To Appliance" and call your service technician or gas supplier.

#### To Turn Off Gas to Appliance

1. Set the thermostat to the OFF position.
2. Turn off all electric power to the appliance if service is to be performed.

- 3a. 90,000 - 135,000 and 399,999 - 500,000 Btu/hr models, rotate the gas control knob on the gas valve clockwise to the "OFF" position. Do not force.
- 3b. 180,000 - 360,000 Btu/hr models, rotate the gas control knob on the gas valve clockwise to the line on the collar around the knob. Depress the knob and continue rotation to the "OFF" position. Do not force.

#### WARNING

Should overheating occur or the gas fail to shut off, turn off the external manual gas valve to the appliance.

### Safety Shutoff Test for Spark Ignition Pilot System

1. Turn "OFF" gas supply to the appliance.
2. Turn thermostat to highest setting.
3. Turn electric power "ON".
4. Pump relay pulls in to start pump.
5. The ignition will begin sparking at the pilot.
6. The ignition module will lock out after the trial for ignition period.
7. Immediately call a qualified serviceman or installer to repair an ignition system that fails to lock out and properly shut down burner operation.
8. After successful completion of the test, readjust the thermostat to normal setting.
9. Turn "ON" gas supply.
10. Turn power "OFF" then "ON" to reset ignition module.
11. If ignition system fails to operate properly, repair work must be performed by a qualified serviceman or installer.

### Intermittent Pilot Spark Ignition System

#### WARNING

The ignition module is not repairable. Any modification or repairs will invalidate the warranty and may create hazardous conditions that result in property damage, personal injury, fire, explosion and/or toxic gases. A faulty ignition module must be replaced with a new module.



**Revision Notes:** *Revision A (ECO C06290) initial release.*

*Revision B (ECO C12077) reflects the update of ignition timing information on page 11.*

*Revision C (PCP #3000021634 / CN #500011858) reflects an update to the chart on page 5.*

*Revision D (PCP #3000030852 / CN #500020656) reflects an update to the owner maintenance schedule.*

*CFA-USER\_MM #100160873\_DIR #2000001338\_Rev D  
04/19*