

Copper-Fin[®]

User's Information Manual
Models: 497 - 2067

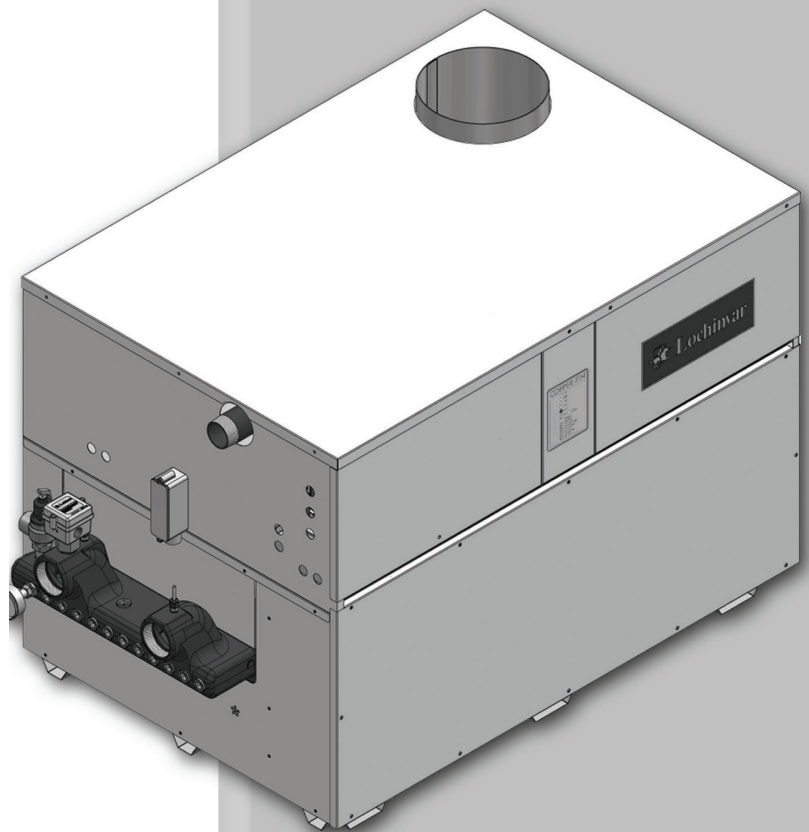

Lochinvar[®]
High Efficiency Water Heaters, Boilers and Pool Heaters

⚠ WARNING

If the information in this manual is not followed exactly, a fire or explosion may result causing property damage, personal injury or loss of life.

This appliance **MUST NOT** be installed in any location where gasoline or flammable vapors are likely to be present.

WHAT TO DO IF YOU SMELL GAS

- Do not try to light any appliance.
- Do not touch any electric switch; do not use any phone in your building.
- Immediately call your gas supplier from a near by phone. Follow the gas supplier's instructions.
- If you cannot reach your gas supplier, call the fire department.
- Installation and service must be performed by a qualified installer, service agency, or the gas supplier.

Save this manual for future reference.

Contents

HAZARD DEFINITIONS	2	3. OPERATING INSTRUCTIONS.....	8
PLEASE READ BEFORE PROCEEDING	3	4. IGNITION MODULE	
1. PREVENT COMBUSTION AIR CONTAMINATION.....	4	Diagnostic Status Indication.....	9
2. MAINTENANCE SCHEDULE.....	5	Ignition and Control Timings	9
Maintenance Procedures	6	Operation and Diagnostic Lights.....	10
Boiler Must Be Serviced and Maintained	6	Revision Notes	Back Cover
Check Boiler Area.....	6		
Check Pressure Temperature Gauge.....	6		
Check Vent Piping	6		
Check Air Piping	6		
Check Relief Valve	6		
Test Low Water Cutoff (if installed)	7		
Reset Button (low water cutoff)	7		
Check Boiler Piping (gas and water).....	7		
Operate Relief Valve	7		
Shut Boiler Down.....	7		

Hazard definitions

The following defined terms are used throughout this manual to bring attention to the presence of hazards of various risk levels or to important information concerning the life of the product.

DANGER

DANGER indicates an imminently hazardous situation which, if not avoided, will result in death or serious injury.

WARNING

WARNING indicates a potentially hazardous situation which, if not avoided, could result in death or serious injury.

CAUTION

CAUTION indicates a potentially hazardous situation which, if not avoided, may result in minor or moderate injury.

CAUTION

CAUTION used without the safety alert symbol indicates a potentially hazardous situation which, if not avoided, may result in property damage.

NOTICE

NOTICE indicates special instructions on installation, operation, or maintenance that are important but not related to personal injury or property damage.

Please read before proceeding

NOTICE

This is a gas appliance and should be installed by a licensed electrician and/or certified gas supplier. Service must be performed by a qualified service installer, service agency or the gas supplier.

⚠ WARNING

If the information in these instructions is not followed exactly, a fire or explosion may result causing property damage, personal injury, or death.

This appliance **MUST NOT** be installed in any location where gasoline or flammable vapors are likely to be present, unless the installation is such to eliminate the probable ignition of gasoline or flammable vapors.

What to do if you smell gas –

- Do not try to light any appliance.
- Do not touch any electric switch; do not use any phone in your building.
- Immediately call your gas supplier from a neighbors phone. Follow the gas supplier's instructions.
- If you cannot reach your gas supplier, call the fire department.

Installation and service must be performed by a qualified installer, service agency, or the gas supplier.

Warranty –

Factory warranty (shipped with unit) does not apply to units improperly installed or improperly operated.

Experience has shown that improper installation or system design, rather than faulty equipment, is the cause of most operating problems.

1. Excessive water hardness causing a lime/scale build-up in the copper tube is not the fault of the equipment and is not covered under the manufacturer's warranty (see *Water Treatment and Water Chemistry in the Copper-fin Installation and Operation Manual*).
2. Excessive pitting and erosion on the inside of the copper tube may be caused by too much water velocity through the tubes and is not covered by the manufacturer's warranty (see *Boiler Flow Rates and Temperature Rise for flow requirements in the Copper-fin Installation and Operation Manual*).

⚠ WARNING

Improper installation, adjustment, alteration, service or maintenance can cause injury or property damage. Refer to this manual for assistance or additional information, consult a qualified installer, service agency or the gas supplier.

Checking equipment –

Upon receiving equipment, check for signs of shipping damage. Pay particular attention to parts accompanying the appliance which may show signs of being hit or otherwise being mishandled. Verify total number of pieces shown on the packing slip with those actually received. In case there is damage or a shortage, immediately notify the carrier.

Do not use this appliance if any part has been under water. The possible damage to a flooded appliance can be extensive and present numerous safety hazards. Any appliance that has been under water must be replaced.

⚠ Owner warning –

The information contained in this manual is intended for use by qualified professional installers, service technicians, or gas suppliers. **Consult your local expert for proper installation or service procedures.**

NOTICE

Consult and follow all local Building and Fire Regulations and other Safety Codes that apply to this installation. Consult a local gas utility company to authorize and inspect all gas and flue connections.

Your conventionally vented gas appliance must have a supply of fresh air circulating around it during burner operation for proper gas combustion and proper venting.

⚠ WARNING

Should overheating occur or the gas supply fail to shut off, do not turn off or disconnect the electrical supply to the pump. Instead, turn off the manual gas control valve to the appliance at a location external to the appliance.

Prevention of freezing –

Heat exchangers and headers damaged by freezing are not covered by warranty.

See Section 6, *Startup - Freeze Protection* in the Copper-fin Installation and Operation for more information.

1 Prevent combustion air contamination

⚠ WARNING

If the boiler combustion air inlet is located in any area likely to cause contamination, or if products which would contaminate the air cannot be removed, you must have the combustion air and vent re-piped and terminated to another location. Contaminated combustion air will damage the boiler, resulting in possible severe personal injury, death, or substantial property damage.

⚠ WARNING

If the boiler combustion air inlet is located in a laundry room or pool facility, for example, these areas will always contain hazardous contaminants.

Pool and laundry products and common household and hobby products often contain fluorine or chlorine compounds. When these chemicals pass through the boiler, they can form strong acids. The acid can eat through the boiler wall, causing serious damage and presenting a possible threat of flue gas spillage or boiler water leakage into the building.

Please read the information listed in Table 1A. If contaminating chemicals will be present near the location of the boiler combustion air inlet, have your installer pipe the boiler combustion air and vent to another location, per the Copper-fin Installation and Operation Manual.

⚠ WARNING

To prevent the potential of severe personal injury or death, check for areas and products listed in Table 1A before installing the boiler or air inlet piping.

If contaminants are found, you MUST:

- Remove contaminants permanently.
- OR—
- Relocate air inlet and vent terminations to other areas.

Table 1A Corrosive Contaminants and Sources

Products to avoid:
Spray cans containing chloro/fluorocarbons
Permanent wave solutions
Chlorinated waxes/cleaners
Chlorine-based swimming pool chemicals
Calcium chloride used for thawing
Sodium chloride used for water softening
Refrigerant leaks
Paint or varnish removers
Hydrochloric acid/muriatic acid
Cements and glues
Antistatic fabric softeners used in clothes dryers
Chlorine-type bleaches, detergents, and cleaning solvents found in household laundry rooms
Adhesives used to fasten building products and other similar products
Areas likely to have contaminants
Dry cleaning/laundry areas and establishments
Swimming pools
Metal fabrication plants
Beauty shops
Refrigeration repair shops
Photo processing plants
Auto body shops
Plastic manufacturing plants
Furniture refinishing areas and establishments
New building construction
Remodeling areas
Garages with workshops

2 Maintenance schedule

Service technician		Owner maintenance (see pages 6 - 7 for detailed instructions)	
ANNUAL START-UP	General:	Daily	<ul style="list-style-type: none"> • Check boiler area • Check pressure/temperature gauge
	<ul style="list-style-type: none"> • Address reported problems • Inspect interior; clean and vacuum if necessary; • Check for leaks (water, gas, flue, condensate) • Examine venting system • Check fill water meter • Test boiler water. When test indicates, clean system water with approved system restorer following manufacturer's information. • Check system water pressure/system piping/expansion tank • Check control settings • Check igniter • Check wiring and connections • Check flue gas passageways • Flame inspection (stable, uniform) • Inspect and clean the burner • Check manifold gas pressure • Perform start-up checkout and performance verification per Section 6 in the Copper-fin Installation and Operation Manual 	Monthly	<ul style="list-style-type: none"> • Check vent piping • Check air piping • Check air and vent termination screens • Check relief valve • Check air vents • Remove debris from Y-strainer • Check building recirculation filter (if filter required)
	<p>If combustion or performance indicate need:</p> <ul style="list-style-type: none"> • Clean heat exchanger • Remove and clean burner using compressed air only • Clean the blower wheel 	Periodically	<ul style="list-style-type: none"> • Test low water cutoff (if used) • Reset button (low water cutoff)
		Every 6 months	<ul style="list-style-type: none"> • Check boiler piping (gas and water) for leaks • Operate relief valve
		End of season months	<ul style="list-style-type: none"> • Shut boiler down (unless boiler used for domestic hot water)



WARNING

Follow the maintenance procedures given throughout this manual. Failure to perform the service and maintenance or follow the directions in this manual could result in damage to the boiler or system, resulting in severe personal injury, death, or substantial property damage.

2 Maintenance schedule

Maintenance procedures

Appliance must be serviced and maintained

⚠ WARNING

The appliance must be inspected and started annually at the beginning of the heating season by a qualified service technician. In addition, the maintenance and care of the appliance designated on page 5 of this manual and explained on pages 6 and 7 must be performed to assure maximum appliance efficiency and reliability. Failure to service and maintain the appliance and system could result in equipment failure, causing possible severe personal injury, death, or substantial property damage.

NOTICE

The following information provides detailed instructions for completing the maintenance items listed in the maintenance schedule on page 5. In addition to this maintenance, the appliance must be serviced and started up at the beginning of each heating season by a qualified service technician.

Check appliance area

⚠ WARNING

To prevent potential of severe personal injury, death, or substantial property damage, eliminate all materials discussed below from the boiler/water heater vicinity and the vicinity of the boiler/water heater combustion air inlet. If contaminants are found:

Remove products immediately from the area. If they have been there for an extended period, call a qualified service technician to inspect the appliance for possible damage from acid corrosion.

If products cannot be removed, immediately call a qualified service technician to re-pipe vent and air piping and locate vent termination/air intake away from contaminated areas.

1. Combustible/flammable materials -- Do not store combustible materials, gasoline or any other flammable vapors or liquids near the appliance. Remove immediately if found.
2. Air contaminants -- Products containing chlorine or fluorine, if allowed to contaminate the appliance intake air, will cause acidic condensate in the appliance. This will cause significant damage to the appliance if allowed to continue.

Check vent piping

1. Visually inspect the flue gas vent piping for any signs of blockage, leakage, or deterioration of the piping. Notify your qualified service technician at once if you find any problems.

⚠ WARNING

Failure to inspect the vent system as noted above and have it repaired by a qualified service technician can result in vent system failure, causing severe personal injury or death.

Check pressure/temperature gauge

1. Make sure the pressure reading on the boiler pressure/temperature gauge does not exceed 24 PSI. Higher pressure may indicate a problem with the expansion tank.
2. Contact a qualified service technician if problem persists.

Check vent piping

1. Visually inspect the flue gas vent piping for any signs of blockage, leakage, or deterioration of the piping. Notify your qualified service technician at once if you find any problems.

⚠ WARNING

Failure to inspect the vent system as noted above and have it repaired by a qualified service technician can result in vent system failure, causing severe personal injury or death.

Check air piping

1. Visually inspect the air inlet elbow to be sure it is unobstructed. Inspect the entire length of air piping to ensure piping is intact and all joints are properly sealed.
2. Call your qualified service technician if you notice any problems.

Check relief valve

1. Inspect the appliance relief valve and the relief valve discharge pipe for signs of weeping or leakage.
2. If the relief valve often weeps, immediately contact your qualified service technician to inspect the appliance and system.

2 Maintenance schedule *(continued)*

Test low water cutoff (if installed)

1. If the system is equipped with a low water cutoff, test the low water cutoff periodically during the heating season, following the low water cutoff manufacturer's instructions.

Reset button (low water cutoff)

1. Testing the low water cutoff shuts the unit off. Press the RESET button on the low water cutoff bracket to turn the unit back on.

Check appliance piping (gas and water)

1. Remove the appliance front access door and perform a gas leak inspection per steps 1 through 7 of the Operating Instructions on page 8. If gas odor or leak is detected, immediately shut down the appliance following the procedures on page 8. Call a qualified service technician.
2. Visually inspect for leaks around water piping. Also inspect the circulators, relief valve, and fittings. Immediately call a qualified service technician to repair any leaks.

⚠ WARNING

Have leaks fixed at once by a qualified service technician. Failure to comply could result in severe personal injury, death, or substantial property damage.

3. Replace the front access door.

Operate relief valve

1. Before proceeding, verify that the relief valve outlet has been piped to a safe place of discharge, avoiding any possibility of scalding from hot water.

⚠ WARNING

To avoid water damage or scalding due to valve operation, a metal discharge line must be connected to the relief valve outlet and run to a safe place of disposal. This discharge line must be installed by a qualified heating installer or service technician in accordance with the instructions in the Copper-fin Installation and Operation Manual. The discharge line must be terminated so as to eliminate possibility of severe burns or property damage should the valve discharge.

2. Read the boiler pressure/temperature gauge to make sure the system is pressurized. Lift the relief valve top lever slightly, allowing water to relieve through the valve and discharge piping.
3. If water flows freely, release the lever and allow the valve to seat. Watch the end of the relief valve discharge pipe to ensure that the valve does not weep after the line has had time to drain. If the valve weeps, lift the seat again to attempt to clean the valve seat. If the valve continues to weep afterwards, contact your qualified service technician to inspect the valve and system.
4. If water does not flow from the valve when you lift the lever completely, the valve or discharge line may be blocked. Immediately shut down the appliance, following the operating instructions on page 8 of this manual. Call your qualified service technician to inspect the appliance and system.

Shut appliance down (unless boiler is used for Domestic Water)

1. Follow "To Turn Off Gas to Appliance" on page 8 of this manual.
2. Do not drain the system unless exposure to freezing temperatures will occur.
3. Do not drain the system if it is filled with an antifreeze solution.
4. DO NOT shut down appliances used for domestic water heating, they must operate year-round.

3 Operating instructions

FOR YOUR SAFETY READ BEFORE OPERATING

WARNING: If you do not follow these instructions exactly, a fire or explosion may result causing property damage, personal injury or loss of life.

A. This appliance is equipped with an ignition device which automatically lights the burner. Do not try to light the burner by hand.

B. BEFORE OPERATING smell all around the appliance area for gas. Be sure to smell next to the floor because some gas is heavier than air and will settle on the floor.

FOR YOUR SAFETY "WHAT TO DO IF YOU SMELL GAS"

- Do not try to light any appliance.
- Do not touch any electrical switch; do not use any phone in your building.
- Immediately call your gas supplier from a neighbor's phone. Follow the gas supplier's instructions.

◦ If you cannot reach your gas supplier, call the fire department.

C. Use only your hand to turn the gas control knob. Never use tools. If the knob will not turn by hand, don't try to repair it, call a qualified service technician. Force or attempted repair may result in a fire or explosion.

D. Do not use this appliance if any part has been under water. Immediately call a qualified service technician to inspect the appliance and to replace any part of the control system and any gas control which has been under water.

OPERATING INSTRUCTIONS

1. STOP! Read the safety information above on this label.
2. Turn off all electric power to the appliance.
3. Open control access panel.
4. This appliance is equipped with an ignition device which automatically lights the burner. Do not try to light the burner by hand.

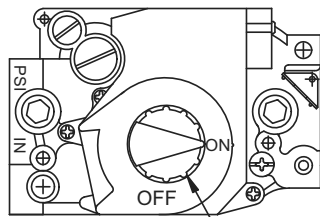

GAS CONTROL KNOB
SHOWN IN THE "ON" POSITION

5. Push in gas control knob slightly and turn clockwise to "OFF."



NOTE: On the 36C valve, knob cannot be turned to "OFF" unless knob is pushed in slightly. Do not force.

6. Wait five (5) minutes to clear out any gas. Then smell for gas, including near the floor. If you smell gas, STOP! Follow "B" in the safety information above on this label. If you don't smell gas, go to the next step".

7. Turn gas control knob counterclockwise to "ON."



8. Replace control access panel.
9. Turn on all electric power to the appliance.
10. If the appliance will not operate, follow the instructions "To Turn Off Gas To Appliance" and call your service technician or gas supplier.

TO TURN OFF GAS TO APPLIANCE

1. Turn off all electric power to the appliance if service is to be performed.

2. Open control access panel.

3. Push in gas control knob slightly and turn clockwise to "OFF". Do not force.



4. Replace control access panel.

LBL2084 REV D

4 Ignition module

Diagnostic Status Indication

The ignition module has an LED which indicates the status of the safety circuits. A remote Ignition Module Status indicating light is wired from the ignition module Status LED and mounted on the diagnostic panel. The flashing operation of this light indicates the diagnostic status of the ignition control module. The status LED, mounted on the ignition module flashes a code sequence from the Ignition Module to indicate the status of the ignition process. See Table 4A for the flashing diagnostic status codes as signaled by the ignition module

Note: Flame current is typically 2 - 6 μ A

Figure 4-1 Hot surface ignition control module

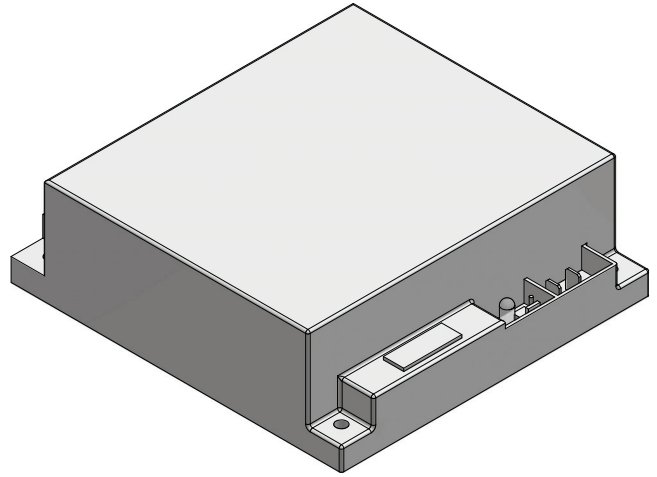

4 Ignition module

Operation and diagnostic lights

The diagnostic control panel has up to 6 indicating and diagnostic lights to show all major steps of operation and control sensed malfunctions. This panel is located on the front of the unit.

TABLE 4A Status LED Diagnostic Codes	
Code Sequence	Condition
Constant ON	System OK, no faults present.
Constant OFF	Possible control fault, check power; LED may be effective, do not replace control if all operational sequences function properly, see Trouble- Shooting Guide.
One Flash	Low Air, check air pressure switch and hoses to pressure sensing points, fan, venting and sealing of pressurized chamber. Note: Brief flashing normal on fan start-up proving.
Two Flashes	Flame without call for heat, check for a gas valve stuck in the open position, air, venting, burners and the combustion process. Fan will remain on.
Three Flashes	Lockout due to flame failure, push reset button on inner control panel after correcting ignition problem. Initial heater start up without properly bleeding air from the gas line may require multiple reset functions to achieve proper ignition.
Four Flashes	Igniter failure, igniter will not maintain a minimum 2.75 amp current draw, caused by, low voltage, bad wiring/continuity, high resistance or igniter failure.
Five Flashes	Power supply problem, check for low supply voltage or transformer output less than 18VAC.
Six Flashes	Replace ignition module, internal fault.

TABLE 4B Status LED Diagnostic Codes	
Code Sequence	Condition Lights
Prepurge	Operation for combustion air fan before ignition on stages 1 and 2.
Trial for Ignition	Hot surface igniter preparing to light burners.
Stage 1 ON	Burners for stage 1 operating.
Stage 2 ON	Burners for stage 2 operating.
Status	Remote status light for ignition module.
Alarm	Indicates flame failure on the ignition module and will indicate additional alarms if the alarm of any failure option is purchased.

Figure 4-2_ Operation / diagnostic lights

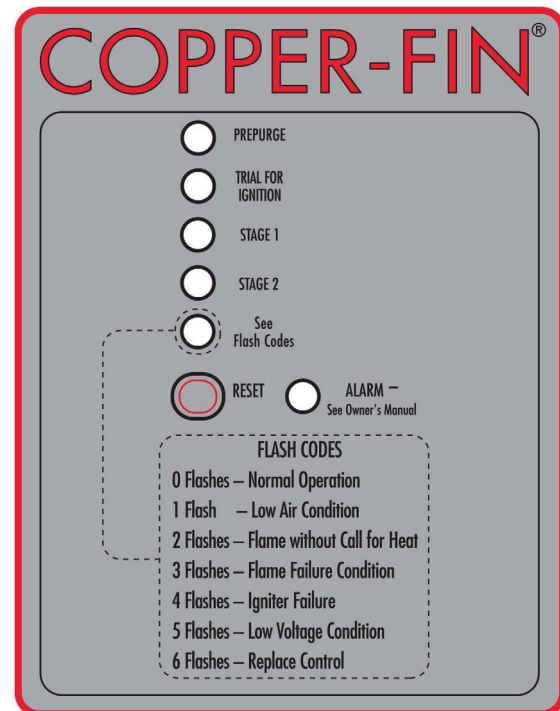

Notes



Revision Notes: *Revision A (ECO C07390) initial release.*

Revision B (ECO C12077) reflects the update of ignition timing information on page 9.

Revision C (PCP #3000021634 / CN #500011858) reflects an update to the chart on page 5.

Revision D (PCP #3000030852 / CN #500020656) reflects an update to the owner maintenance schedule on page 5.

CBX-CWX-USER_MM #100160894_DIR #2000001311_Rev D
04/19