

CREST[®]

CONDENSING BOILER

MODBUS AND BACNET COMMUNICATION INSTRUCTIONS

Crest Models: FB/OF751 - 6001
& FCB1000-6000

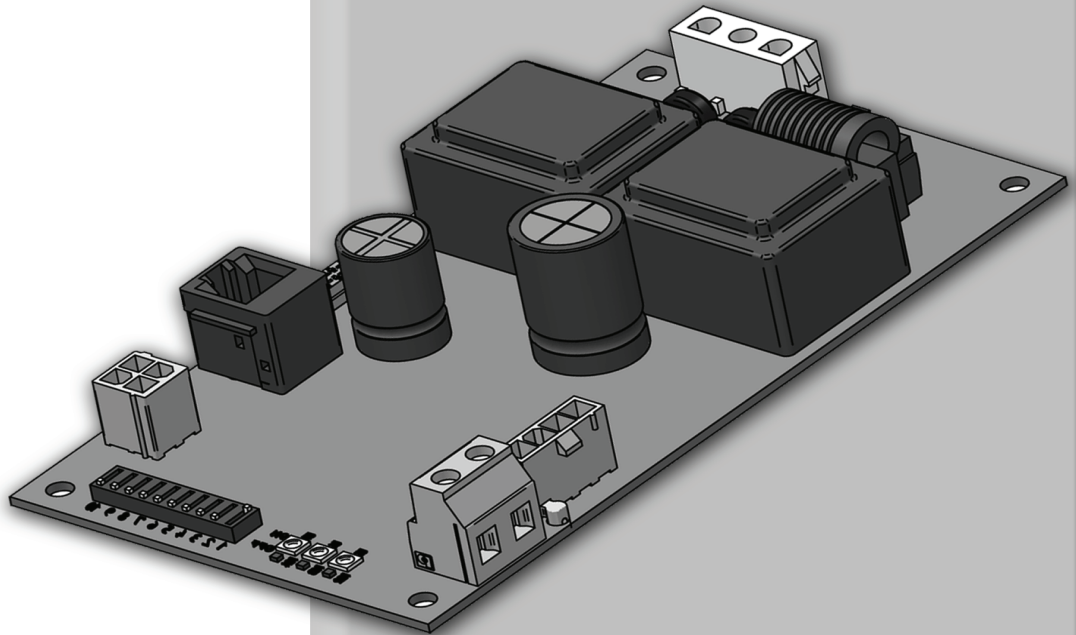

⚠ WARNING

This manual must only be used by a qualified heating installer / service technician. Read all instructions, including this manual, the Installation and Operation Manual, and the Service Manual, before installing. Perform steps in the order given. Failure to comply could result in severe personal injury, death, or substantial property damage.

Contents

<p>1. INTRODUCTION</p> <p style="padding-left: 20px;">Definitions 2</p> <p style="padding-left: 20px;">Minimum System Requirements 2</p> <p>2. MODBUS CONFIGURATION</p> <p style="padding-left: 20px;">Addressing 3</p> <p style="padding-left: 20px;">Timing Specifications 4</p> <p style="padding-left: 20px;">Parity 4</p> <p style="padding-left: 20px;">Data Transmission Mode 4</p> <p style="padding-left: 20px;">ModBus Board Diagnostics 4</p> <p style="padding-left: 40px;">Internal Faults 4</p> <p style="padding-left: 40px;">ModBus Function Set 5</p> <p style="padding-left: 20px;">ModBus Exception Codes 6</p> <p>3. MODBUS MEMORY MAP</p> <p style="padding-left: 20px;">Primary Data Tables 7</p> <p style="padding-left: 20px;">Crest Boiler Memory Map 7-8</p> <p style="padding-left: 40px;">Input Registers 8</p> <p style="padding-left: 40px;">Holding Registers 8</p> <p style="padding-left: 20px;">Configuration Bits 8</p>	<p>4. BACNET CONFIGURATION 9</p> <p style="padding-left: 20px;">Addressing 9</p> <p style="padding-left: 20px;">Timing Specifications 10</p> <p style="padding-left: 20px;">Communication Board Diagnostics 10</p> <p style="padding-left: 20px;">Internal Faults 10</p> <p>5. BACnet MEMORY MAP</p> <p style="padding-left: 20px;">Primary Data Tables 11</p> <p style="padding-left: 20px;">Crest Boiler Memory Map 11-12</p> <p style="padding-left: 40px;">Inputs 12</p> <p style="padding-left: 40px;">Analog Values 12</p> <p>6. WIRING REQUIREMENTS</p> <p style="padding-left: 20px;">Physical Wiring 13</p> <p style="padding-left: 20px;">Typical Boiler System Wiring 14-17</p> <p>7. UNIT OPERATION</p> <p style="padding-left: 20px;">Unit Operation with ModBus and BACnet Communications 18-21</p> <p>8. TROUBLESHOOTING 22-25</p> <p style="padding-left: 20px;">Revision Notes Back Cover</p>
--	--

1 Introduction

The information contained in this manual provides general guidelines for the implementation of ModBus / BACnet communication with the Lochinvar Crest boiler.

All ModBus networks are implemented utilizing a master-slave arrangement where all Crest boilers are slaves and the master is a building automation system capable of communicating over RS-485 serial connections. BACnet networks are implemented using a token passing process where multiple masters and slaves share a common RS-485 bus. The Lochinvar BACnet interface is a master only.

Definitions

Abbreviation or Acronym	Meaning
ASCII	American Standard Code for Information Interchange
BACnet	A data communication protocol for Building Automation and Control Networks
BAS	Building Automation System
Baud (Baud Rate)	Number of data bits transmitted per second (bps)
EMS	Energy Management System
FDX	Full-Duplex
HDX	Half-Duplex
Hex	Hexadecimal Number (0 - 9, A - F)
I/O Box	Input/Output (I/O)
LSB	Least Significant Byte
ModBus®	A serial, half-duplex data transmission protocol developed by AEG Modicon
MSB	Most Significant Byte
RS232	A standard for serial, full-duplex (FDX) transmission of data based on the RS232 Standard
RS485	A standard for serial transmission of data based on the RS-485 Standard
RTU	Remote Terminal Unit

Minimum System Requirements

- BAS system or computer with a serial or USB port with a converter to RS-485.
Shielded twisted pair communication cable.

2 ModBus Configuration

The ModBus or BACnet communication board is equipped with a set of ten dip switches that are used to set the board configuration (address, baud rate, and parity settings). The first eight are used to set the address of each board. The ninth is used to set the baud rate. The tenth is used to set the parity.

Figure 2-1_Communication Board

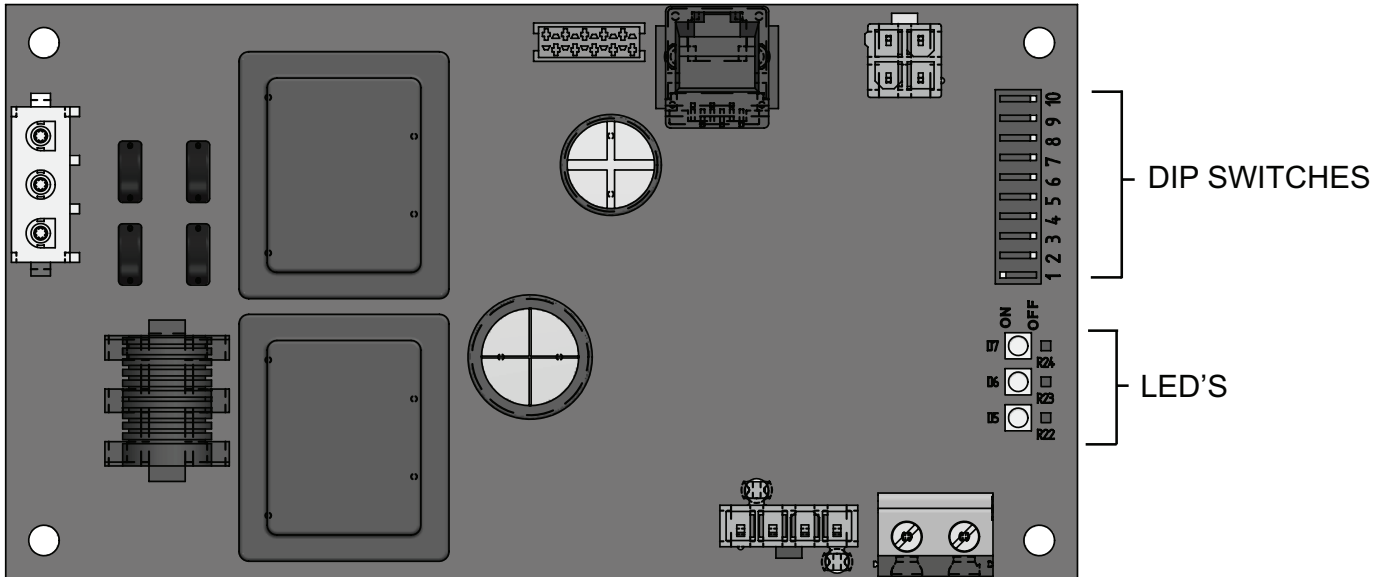

Addressing

The ModBus addressing space is comprised of 256 different addresses.

- 0 is reserved for broadcast messages from the master device
- 1 - 247 are free to use for each unique device
- 248 - 255 are reserved

To set the ModBus address the dip switches can be set in either the 0 position or the 1 position. For switches set to the 1 position their value will be added together to determine the address.

For each switch set to the 1 position it has the following value:

- Dip switch 1 = 1
- Dip switch 2 = 2
- Dip switch 3 = 4
- Dip switch 4 = 8
- Dip switch 5 = 16
- Dip switch 6 = 32
- Dip switch 7 = 64
- Dip switch 8 = 128

Any dip switch set to 0 has a value equal to 0.

Example:

To set the address of the ModBus board to 50, dip switches 2, 5, and 6 have to be set to the 1 position. The address is determined by adding the values of all the dip switches together.

Address = Value of Dip switch 1 + Value of Dip switch 2 + Value of Dip switch 3 + Value of Dip switch 4 + Value of Dip switch 5 + Value of Dip switch 6 + Value of Dip switch 7 + Value of Dip switch 8

In this example:

$$\text{Address} = 0 + 2 + 0 + 0 + 16 + 32 + 0 + 0 = 50$$

2 Modbus Configuration

Timing Specifications

The baud rate for the ModBus board is selectable with Dip switch #9.

- 1 = 19200 bps
- 0 = 9600 bps

Each message is started by at least 3.5 character times of silence. The maximum delay between frames is 1.5 character times.

When the system temperature and/or tank temperature is provided by the BAS to the boiler, it is critical that the temperature be updated every few seconds. If the boiler does not receive updated temperatures within a timeout period (installer adjustable), the control will revert to using its own sensor inputs (if sensors are connected). The timeout is programmable by pressing the MAIN MENU>>SETUP>>MODBUS buttons. The timeout is adjustable between 5 and 120 seconds. The default timeout is 10 seconds.

When the BAS is not providing either of these temperatures, but is still controlling the boiler (such as providing a modulation command), the BAS must refresh these commands at least every 4 minutes. If the commands are not refreshed, the boiler will revert to operating based on its own inputs.

Parity

Parity is set by the position of Dip switch #10.

- 0 = No Parity
- 1 = Even Parity

If No Parity is selected there will be two stop bits, otherwise there will be one.

Data Transmission Mode

Many ModBus bus master devices can be configured to transmit data in either ModBus RTU or ModBus ASCII modes. Since RTU messages can be formatted to use fewer data bits and are therefore more efficient, RTU has been chosen to be used with all Lochinvar ModBus communication. Please ensure that the master device is transmitting ModBus RTU.

ModBus Board Diagnostics

The ModBus board is equipped with three LED's for visual diagnostics: Two yellow LED's and one green. One yellow LED (D5) is used to indicate transmission of data. The other yellow LED (D6) is used to indicate reception of data. The green LED (D7) is used to show internal faults.

Internal Faults:

- Normal Operation = 1 second bright, 1 second dim
- Controller Fault = Continuously on
- No Burner Control Communication = 0.5 seconds on, 1.5 seconds off
- No ModBus Communication = 1.5 seconds on, 0.5 seconds off

ModBus Communication

The ModBus communication commands and exception codes that are supported by the ModBus communication board can be found on pages 5 and 6 of this manual.

2 ModBus Configuration *(continued)*

ModBus Function Set

Function		Sub Function	HEX	Description
Dec	HEX	Dec		
1	01			Read Coil Status
2	02			Read Input Status
3	03			Read Holding Registers
4	04			Read Input Registers
5	05			Force Single Coil
6	06			Preset Single Register
7	07			Read Exception Status
8	08	0	00	Diagnostic - Return Query Data
		1	01	Diagnostic - Restart Communication
		2	02	Diagnostic - Return Diagnostic Register
		4	04	Diagnostic - Force Listen Mode
		10	0A	Diagnostic - Clear Counters and Diagnostic Registers
		11	0B	Diagnostic - Return Bus Message Count
		12	0C	Diagnostic - Bus Communication Error Count
		13	0D	Diagnostic - Bus Exception Error Count
		14	0E	Diagnostic - Return Slave Message Count
		15	0F	Diagnostic - Return Communication Error Count
		16	10	Diagnostic - Return Slave NAK Count
		17	11	Diagnostic - Return Slave Busy Count
		18	12	Diagnostic - Return Bus Character Overrun Count
		20	14	Diagnostic - Clear Overrun Counter and Flag
11	0B			Get Communication Event Counter
12	0C			Get Communication Event Log
15	0F			Write Multiple Coils
16	10			Write Multiple Registers
17	11			Report Slave ID
23	17			Read / Write Multiple Registers

2 ModBus Configuration

ModBus Exception Codes

MODBUS / BACnet Exception Codes		
Code	Name	Meaning
01	ILLEGAL FUNCTION	The function code received in the query is not an allowable action for the server (or slave). This may be because the function code is only applicable to newer devices, and was not implemented in the unit selected. It could also indicate that the server (or slave) is in the wrong state to process a request of this type, for example because it is unconfigured and is being asked to return register values.
02	ILLEGAL DATA ADDRESS	The data address received in the query is not an allowable address for the server (or slave). More specifically, the combination of reference number and transfer length is invalid. For a controller with 100 registers, the PDU addresses the first register as 0, and the last one as 99. If a request is submitted with a starting register address of 96 and a quantity of registers of 4, then this request will successfully operate (address-wise at least) on registers 96, 97, 98, 99. If a request is submitted with a starting register address of 96 and a quantity of registers of 5, then this request will fail with Exception Code 0x02 "Illegal Data Address" since it attempts to operate on registers 96, 97, 98, 99 and 100, and there is no register with address 100.
03	ILLEGAL DATA VALUE	A value contained in the query data field is not an allowable value for server (or slave). This indicates a fault in the structure of the remainder of a complex request, such as that the implied length is incorrect. It specifically does NOT mean that a data item submitted for storage in a register has a value outside the expectation of the application program, since the MODBUS protocol is unaware of the significance of any particular value of any particular register.
04	SLAVE DEVICE FAILURE	An unrecoverable error occurred while the server (or slave) was attempting to perform the requested action.
05	ACKNOWLEDGE	Specialized use in conjunction with programming commands. The server (or slave) has accepted the request and is processing it, but a long duration of time will be required to do so. This response is returned to prevent a timeout error from occurring in the client (or master). The client (or master) can next issue a Poll Program Complete message to determine if processing is completed.
06	SLAVE DEVICE BUSY	Specialized use in conjunction with programming commands. The server (or slave) is engaged in processing a long -- duration program command. The client (or master) should re-transmit the message later when the server (or slave) is free.
08	MEMORY PARITY ERROR	Specialized use in conjunction with function codes 20 and 21 and reference type 6, to indicate that the extended file area failed to pass a consistency check. The server (or slave) attempted to read record file, but detected a parity error in the memory. The client (or master) can retry the request, but service may be required on the server (or slave) device.
0A	GATEWAY PATH UNAVAILABLE	Specialized use in conjunction with gateways, indicates that the gateway was unable to allocate an internal communication path from the input port to the output port for processing as the request. Usually means that the gateway is misconfigured or overloaded.
0B	GATEWAY TARGET DEVICE FAILED TO RESPOND	Specialized use in conjunction with gateways, indicates that no response was obtained from the target device. Usually means that the device is not present on the network.

3 ModBus Memory Map

Primary Data Tables

Table	Data Type	Read / Write
Discrete Inputs	Single Bit	Read Only
Coils	Single Bit	Read / Write
Input Registers	16-Bit Word	Read Only
Holding Registers	16 Bit Word	Read / Write

Crest Boiler Memory Map

Coils						
Address	Description	Default	Unit	Min.	Max.	Resolution
00001	Boiler Enable	0	1=ON / 0=OFF	0	1	1
00005	Tank Thermostat	0	1=ON / 0=OFF	0	1	1
Discrete Inputs						
10001	Manual Reset High Limit	0	1=ON / 0=OFF	0	1	1
10002	Flow Switch	0	1=ON / 0=OFF	0	1	1
10003	Gas Pressure Switch	0	1=ON / 0=OFF	0	1	1
10004	Louver Proving Switch	0	1=ON / 0=OFF	0	1	1
10005	Blower Proving Switch 1*	0	1=ON / 0=OFF	0	1	1
10006	Blocked Drain Switch	0	1=ON / 0=OFF	0	1	1
10008	Flame 1	0	1=ON / 0=OFF	0	1	1
10009	Enable	0	1=ON / 0=OFF	0	1	1
10010	Tank Thermostat	0	1=ON / 0=OFF	0	1	1
10011	Blocked Flue	0	1=ON / 0=OFF	0	1	1
10013	Blower Proving Switch 2*	0	1=ON / 0=OFF	0	1	1
10018	Internal LWCO **	0	1=ON / 0=OFF	0	1	1
10019	Gas Pressure Switch 2 **	0	1=ON / 0=OFF	0	1	1
10021	Flue Damper Proving Switch	0	1=ON / 0=OFF	0	1	1
10023	Flame 2	0	1=ON / 0=OFF	0	1	1
10033	Run-time Contacts	0	1=ON / 0=OFF	0	1	1
10034	Alarm Contacts	0	1=ON / 0=OFF	0	1	1
10035	SH Pump	0	1=ON / 0=OFF	0	1	1
10036	HWG Pump	0	1=ON / 0=OFF	0	1	1
10037	Louver Relay	0	1=ON / 0=OFF	0	1	1
10038	Gas Valve 1	0	1=ON / 0=OFF	0	1	1
10039	System Pump	0	1=ON / 0=OFF	0	1	1
10044	Vent Damper Relay	0	1=ON / 0=OFF	0	1	1
10046	Gas Valve 2	0	1=ON / 0=OFF	0	1	1
10047	Transition Gas Valve	0	1=ON / 0=OFF	0	1	1
10049	Blower #1 Power	0	1=ON / 0=OFF	0	1	1
10050	Blower #2 Power*	0	1=ON / 0=OFF	0	1	1
10051	Spark Igniter	0	1=ON / 0=OFF	0	1	1
10052	Air Valve Trigger*	0	1=ON / 0=OFF	0	1	1
10053	Air Valve Proving*	0	1=ON / 0=OFF	0	1	1

* Crest Models FB/OF1501 - 6001 Only **Crest FCB1000-6000 Only

3 ModBus Memory Map

Crest Boiler Memory Map

Input Registers						
Address	Description	Default	Unit	Min.	Max.	Resolution
30001	Discrete Inputs 1 - 16	0	NA	0	65535	1
30002	Discrete Inputs 17 - 32	0	NA	0	65535	1
30003	Discrete Inputs 33 - 48	0	NA	0	65535	1
30004	System / Cascade Setpoint	0	Degrees Celsius	0	130	0,5
30005	System Pump Speed In	0	%	0	100	1
30006	Cascade Total Power	0	%	100	800	1
30007	Cascade Current Power	0	%	0	800	1
30008	Outlet Setpoint	0	Degrees Celsius	0	130	0,5
30009	Outlet Temperature	0	Degrees Celsius	0	130	0,1
30010	Inlet Temperature	0	Degrees Celsius	-20	130	0,1
30011	Flue Temperature	0	Degrees Celsius	-20	130	0,1
30012	Firing Rate	0	%	0	100	1
30013	Boiler Pump Speed Out	0	%	0	100	1
30014	Boiler Status Code	0	NA	0	65535	1
30015	Boiler Blocking Code	0	NA	0	65535	1
30016	Boiler Lockout Code	0	NA	0	65535	1
30023	O2 Sensor Status **	0	NA	0	65535	1
30024	Current Trim Factor **	0	NA	0	65535	1
30025	Barometer **	0	NA	0	65535	1
30026	Discrete Inputs 49 - 64	0	NA	0	65535	1
30027	Lock-out Error Leader*	0	NA	0	65535	1
30028	Lock-out Error Member 1*	0	NA	0	65535	1
30029	Lock-out Error Member 2*	0	NA	0	65535	1
30030	Lock-out Error Member 3*	0	NA	0	65535	1
30031	Lock-out Error Member 4*	0	NA	0	65535	1
30032	Lock-out Error Member 5*	0	NA	0	65535	1
30033	Lock-out Error Member 6*	0	NA	0	65535	1
30034	Lock-out Error Member 7*	0	NA	0	65535	1
30036	Flame 1 **	0	NA	0	65535	1
30037	Flame 2 **	0	NA	0	65535	1
30038	Correct O2 Reading **	0	NA	0	65535	1
Holding Registers						
40001	Configuration	0	NA	0	65535	1
40002	Coils	0	NA	0	65535	1
40003	0-10 Volt Input / Rate Command / Setpoint Command	0	%	0	100	1
40004	Tank Setpoint	0	Degrees Celsius	0	87,5	0,5
40005	Tank Temperature	0	Degrees Celsius	-20	130	0,1
40006	Outdoor Temperature	0	Degrees Celsius	-40	60	0,1
40007	System Supply Temperature	0	Degrees Celsius	-20	130	0,1
40008	System Return Temperature	0	Degrees Celsius	-20	130	0,1

* Crest Models 1501 - 6001 Only **Crest Models FCB1000-6000

Configuration Bits

Address 40001 contains configuration bits sent from the BAS to the boiler. These bits tell the boiler to use its own internal inputs, or inputs from the BAS. When a bit is set to 1, the boiler will ignore the corresponding value contained internally, and expect the BAS to write that value into the Holding Registers. The configuration bits are as follows:

- | | |
|---|------------------------------------|
| Bit 0 (LSB): Boiler Enable | Bit 4: System Supply Temperature |
| Bit 1: Tank Thermostat | Bit 5: Outdoor Temperature |
| Bit 2: Rate Command / 10 - 10V Input / Setpoint Command | Bit 6: Tank Temperature |
| Bit 3: Tank Setpoint | Bit 7: System Return Temperature |
| | Bit 8 - 15: Not Used (Default = 0) |

4 BACnet Configuration

The BACnet communication board is equipped with a set of ten dip switches that are used to set the board configuration (address and baud rate). The first eight are used to set the address of each board. The ninth and tenth are baud rate.

Figure 4-1 _Communication Board

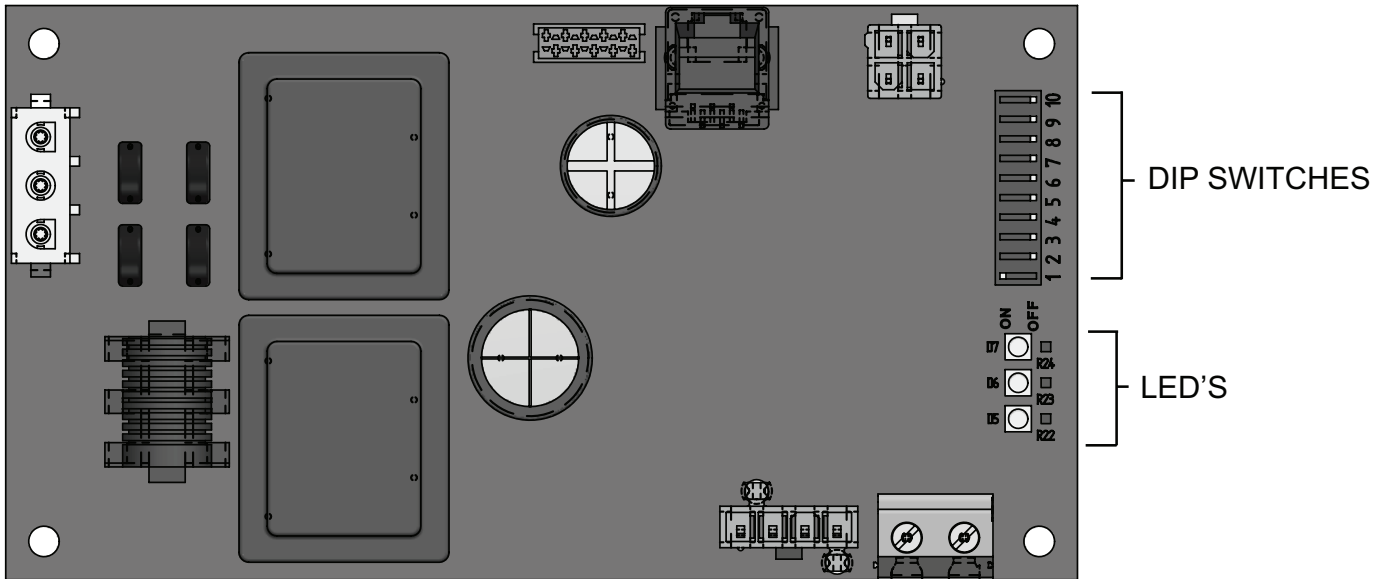

Addressing

The BACnet local addressing space is comprised of 256 different addresses.

- Maximum address of 127.

Since the BACnet communication board is a BACnet master, address 127 is the highest address that can be used.

To set the BACnet local address, the dip switches can be set in either the 0 position or the 1 position. For switches set to the 1 position their value will be added together to determine the address.

For each switch set to the 1 position it has the following value:

- Dip switch 1 = 1
- Dip switch 2 = 2
- Dip switch 3 = 4
- Dip switch 4 = 8
- Dip switch 5 = 16
- Dip switch 6 = 32
- Dip switch 7 = 64

Any dip switch set to 0 has a value equal to 0.

Example:

To set the address of the BACnet board to 50, dip switches 2, 5, and 6 have to be set to the 1 position. The address is determined by adding the values of all the dip switches together.

Address = Value of Dip switch 1 + Value of Dip switch 2 + Value of Dip switch 3 + Value of Dip switch 4 + Value of Dip switch 5 + Value of Dip switch 6 + Value of Dip switch 7

In this example:

$$\text{Address} = 0 + 2 + 0 + 0 + 16 + 32 + 0 = 50$$

The BACnet Device Instance is calculated by adding the BACnet local address to 600000. Using the above example, the Device Instance will be:

$$\text{Device Instance} = 610000 + 50 = 610050$$

The base address (610000 in this example) is model dependant and can be changed by the integrator. It can be set to any value between 0 and 4194048. The resulting device instance will be this value + the local address, as before. Once the base address is changed, it can be reset back to the default base address (610000 in this example) using the following procedure:

1. Turn OFF power to the interface board.
2. Set Dip switches 1 - 8 to the 1 position.
3. Turn ON power to the interface board.
4. After a few seconds, turn OFF power to the interface board.
5. Set Dip switches 1 - 7 to the desired local address.
6. Turn ON power to the interface board.

°F/°C Setting

Accomplish the different selections with Dip switch #8 on the board. The OFF position displays Celsius while the ON position is Fahrenheit.

Device Name

The default device name is "MTR-01 BACnet." This can be changed by the integrator as desired.

4 BACnet Configuration

Timing Specifications

The baud rate for the BACnet board is selectable with Dip switches #9 and #10.

Switch #9	Switch#10	Baud Rate
OFF	OFF	9600
ON	OFF	19200
OFF	ON	38400
ON	ON	76800

When the system temperature and/or tank temperature is provided by the BAS to the boiler, it is critical that the temperature be updated every few seconds. If the boiler does not receive updated temperatures within a timeout period (installer adjustable), the control will revert to using its own sensor inputs (if sensors are connected). The timeout is programmable by pressing the MAIN MENU>>SETUP>>MODBUS buttons. The timeout is adjustable between 5 and 120 seconds. The default timeout is 10 seconds.

When the BAS is not providing either of these temperatures, but is still controlling the boiler (such as providing a modulation command), the BAS must refresh these commands at least every 4 minutes. If the commands are not refreshed, the boiler will revert to operating based on its own inputs.

Communication Board Diagnostics

The Communication board is equipped with three LED's for visual diagnostics: Two yellow LED's and one green. One yellow LED (D5) is used to indicate transmission of data. The other yellow LED (D6) is used to indicate reception of data. The green LED (D7) is used to show internal faults.

Internal Faults:

Normal Operation = 1 second bright, 1 second dim

Controller Fault = Continuously on

No Burner Control Communication = 0.5 seconds on, 1.5 seconds off

No BACnet Communication = 1.5 seconds on, 0.5 seconds off.

5 BACnet Memory Map

Primary Data Tables

Object Type	Data Type	Read / Write
Binary Input (BI)	Single Bit	Read Only
Binary Value (BV)	Single Bit	Read / Write
Analog Input (AI)	16-Bit Word	Read Only
Analog Value (AV)	16 Bit Word	Read / Write

Memory Map

Object Name	Object Type	Object Instance	Units	Min	Max	Resolution
Binary Values						
Boiler Enable	BV	0	none	0	1	1
Tank Thermostat	BV	4	none	0	1	1
Binary Inputs						
Manual Reset High Limit	BI	0	none	0	1	1
Flow Switch	BI	1	none	0	1	1
Gas Pressure Switch	BI	2	none	0	1	1
Louver Proving Switch	BI	3	none	0	1	1
Air Pressure Switch	BI	4	none	0	1	1
Blocked Drain Switch	BI	5	none	0	1	1
Flame 1	BI	7	none	0	1	1
Enable	BI	8	none	0	1	1
Tank Thermostat	BI	9	none	0	1	1
Fan 1 Proving Switch	BI	10	none	0	1	1
Fan 2 Proving Switch	BI	12	none	0	1	1
Internal LWCO ***	BI	17	none	0	1	1
Gas Pressure Switch 2 ***	BI	18	none	0	1	1
Flue Damper Switch	BI	20	none	0	1	1
Flame 2	BI	22	none	0	1	1
Run Time Contacts	BI	32	none	0	1	1
Alarm Contacts	BI	33	none	0	1	1
Boiler Pump	BI	34	none	0	1	1
DHW Pump	BI	35	none	0	1	1
Louver Relay	BI	36	none	0	1	1
Gas Valve 1	BI	37	none	0	1	1
System Pump	BI	38	none	0	1	1
DHW Recirc Pump ***	BI	40	none	0	1	1
Flue Damper Output	BI	43	none	0	1	1
Gas Valve 2	BI	45	none	0	1	1
Transition Gas Valve**	BI	46	none	0	1	1
Main Fan 1	BI	48	none	0	1	1
Main Fan 2*	BI	49	none	0	1	1
External Spark / HSI	BI	50	none	0	1	1
Air Valve Trigger**	BI	51	none	0	1	1
Air Valve Proving**	BI	52	none	0	1	1

* Crest Models 2501 - 6001 Only

** Crest Models 751- 1501 Only

***Crest Models FCB1000-6001 Only

5 BACnet Memory Map

Memory Map *(continued)*

Object Name	Object Type	Object Instance	Units	Min	Max	Resolution
Inputs						
Binary Inputs 0-15	AI	0	none	0	65535	1
Binary Inputs 16-31	AI	1	none	0	65535	1
Binary Inputs 32-47	AI	2	none	0	65535	1
System / Cascade Setpoint	AI	3	Deg. C	0	130	0.5
System Pump Speed	AI	4	Percent	0	100	1
Cascade Total Power	AI	5	Percent	100	800	1
Cascade Current Power	AI	6	Percent	0	800	1
Outlet Setpoint	AI	7	Deg C	0	130	0,5
Outlet Temperature	AI	8	Deg C	0	130	0,1
Inlet Temperature	AI	9	Deg C	-20	130	0,1
Flue Temperature	AI	10	Deg C	-20	130	0,1
Firing Rate	AI	11	Percent	0	100	1
Boiler Pump Speed	AI	12	Percent	0	100	1
Boiler Status Code	AI	13	none	0	65535	1
Boiler Blocking Code	AI	14	none	0	65535	1
Boiler Lockout Code	AI	15	none	0	65535	1
O2 Sensor Status ***	AI	22	none	0	65535	1
Current Trim Factor ***	AI	23	none	0	65535	1
Barometer ***	AI	24	none	0	65535	1
Binary Inputs 48-63	AI	25	none	0	65535	1
Lock-Out Error Leader	AI	26	none	0	1	1
Lock-Out Error Member 1	AI	27	none	0	1	1
Lock-Out Error Member 2	AI	28	none	0	1	1
Lock-Out Error Member 3	AI	29	none	0	1	1
Lock-Out Error Member 4	AI	30	none	0	1	1
Lock-Out Error Member 5	AI	31	none	0	1	1
Lock-Out Error Member 6	AI	32	none	0	1	1
Lock-Out Error Member 7	AI	33	none	0	1	1
Flame 1 ***	AI	35	none	0	65535	1
Flame 2 ***	AI	36	none	0	65535	1
Corrected O2 Reading ***	AI	37	none	0	65535	1
Analog Values						
Configuration	AV	0	none	0	65535	1
Coils	AV	1	none	0	65535	1
0-10 Volt Input / Rate Command / Setpoint Command	AV	2	Percent	0	100	1
Tank Setpoint	AV	3	Deg C	0	87,5	0,5
Tank Temperature	AV	4	Deg C	-20	130	0,1
Outdoor Temperature	AV	5	Deg C	-40	60	0,1
System Supply Temperature	AV	6	Deg C	-20	130	0,1
System Return Temperature	AV	7	Deg C	-20	130	0,1

6 Wiring Requirements

Note that when the System Supply / System Return Temperature and/or the Tank Temperature are provided by the BAS, they need to be refreshed every few seconds. This is required in order to prevent unwanted fluctuations in these temperatures. If these values are not provided every few seconds (timeout is programmable), the boiler will revert to its own internal control. If neither of these temperatures are provided by the BAS, but any of the other control signals are being provided, the BAS will still need to refresh these inputs at least every 4 minutes.

Physical Wiring

RS-485 Communication Bus

- Maximum Length = 4000 feet
- Cable Specification = 24 AWG / A,B (twisted pair) and GND Shielded, with characteristic Impedance = 120 ohm
- Maximum Load = 32 units (32 nodes)

NOTE: Cable must be terminated with 120 ohm impedance matching resistor on each end.
A + (positive)
B - (negative)

Figure 6-1A Crest - Low Voltage Terminal Strip Connections

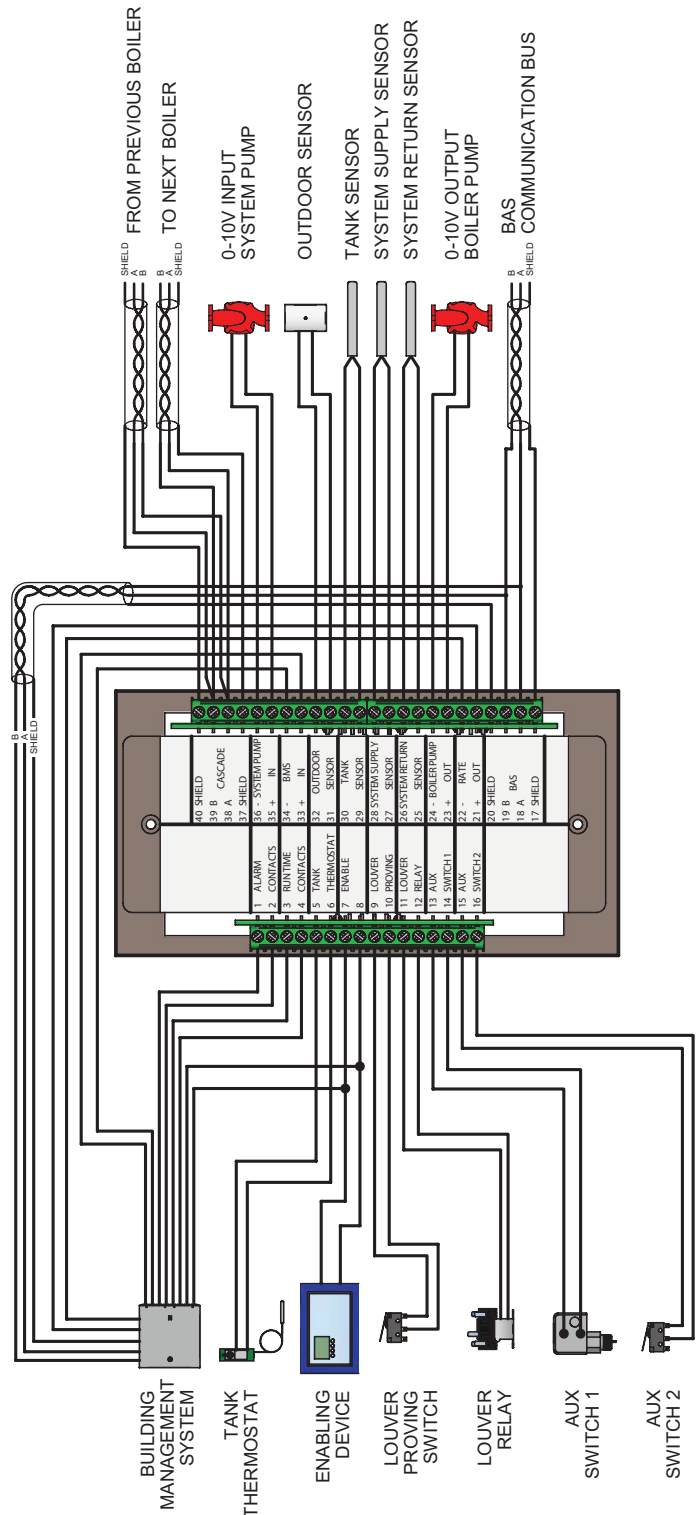

6 Wiring Requirements

Figure 6-1B Hellcat- Low Voltage Terminal Strip Connections

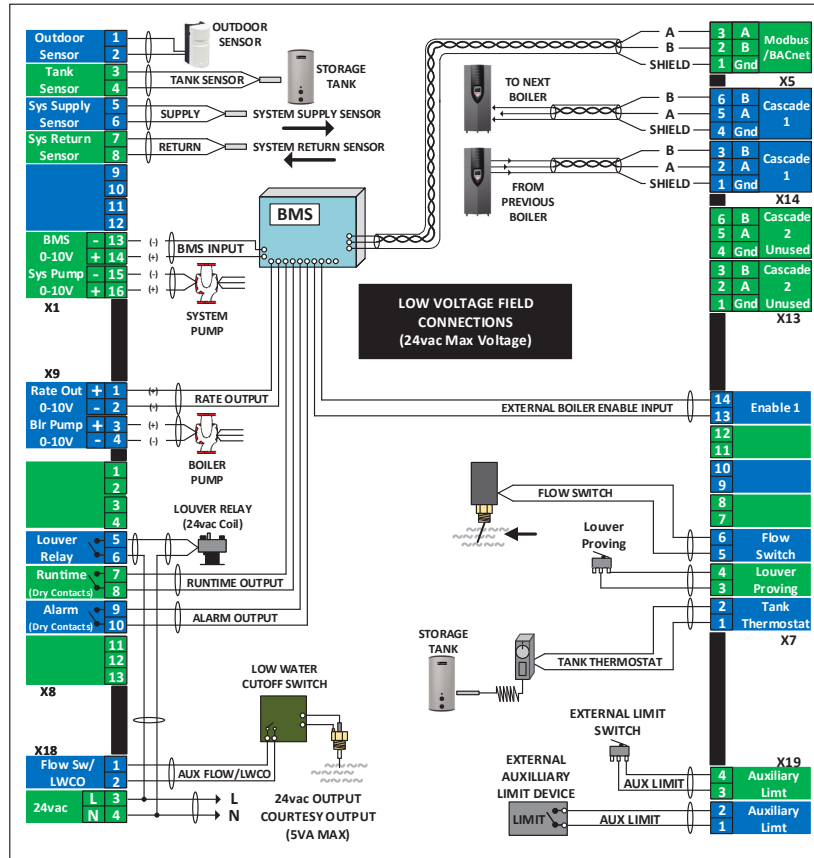

6 Wiring Requirements

Figure 6-2A Crest - Control Inputs

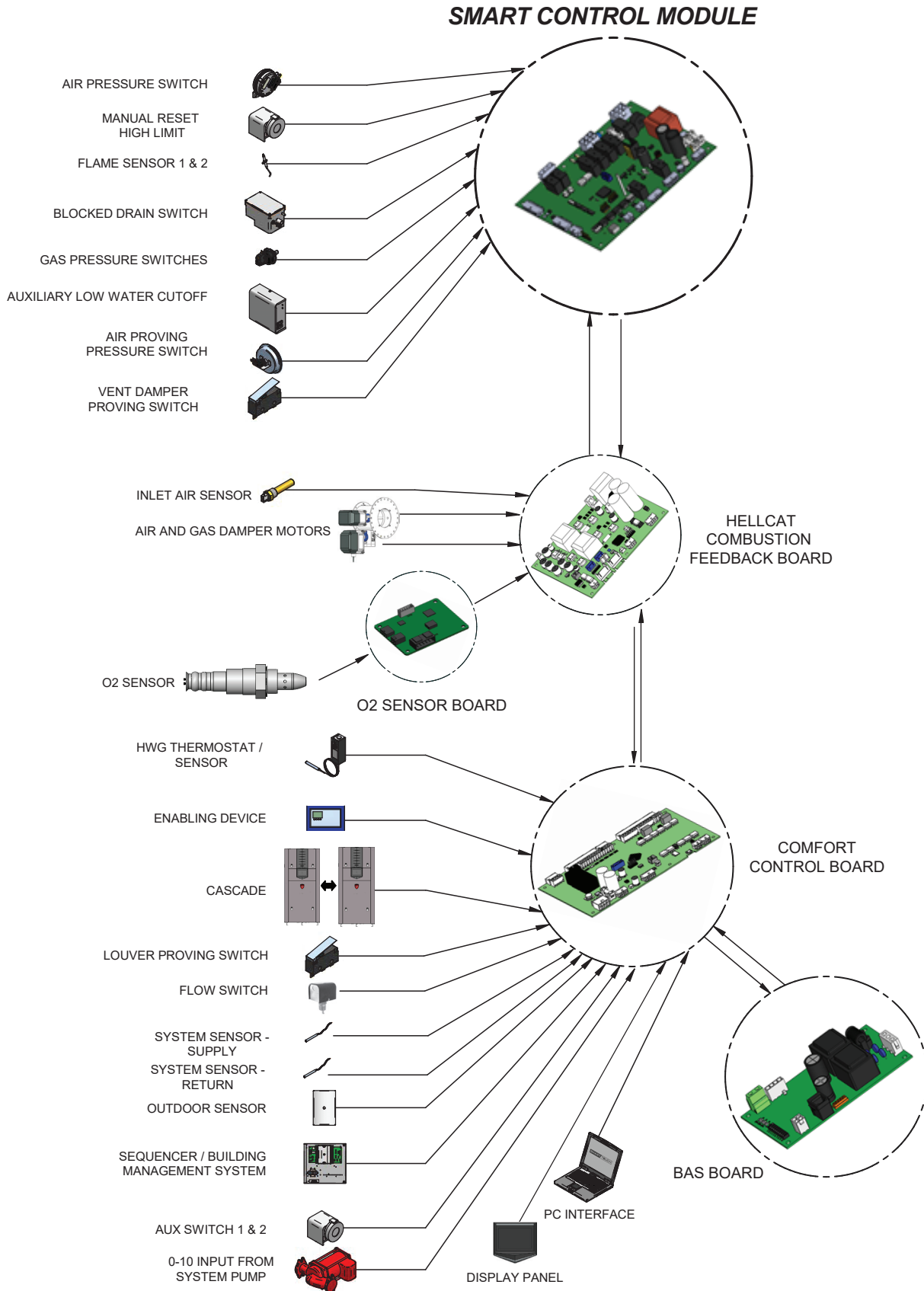

6 Wiring Requirements

Figure 6-2B Hellcat - Control Inputs

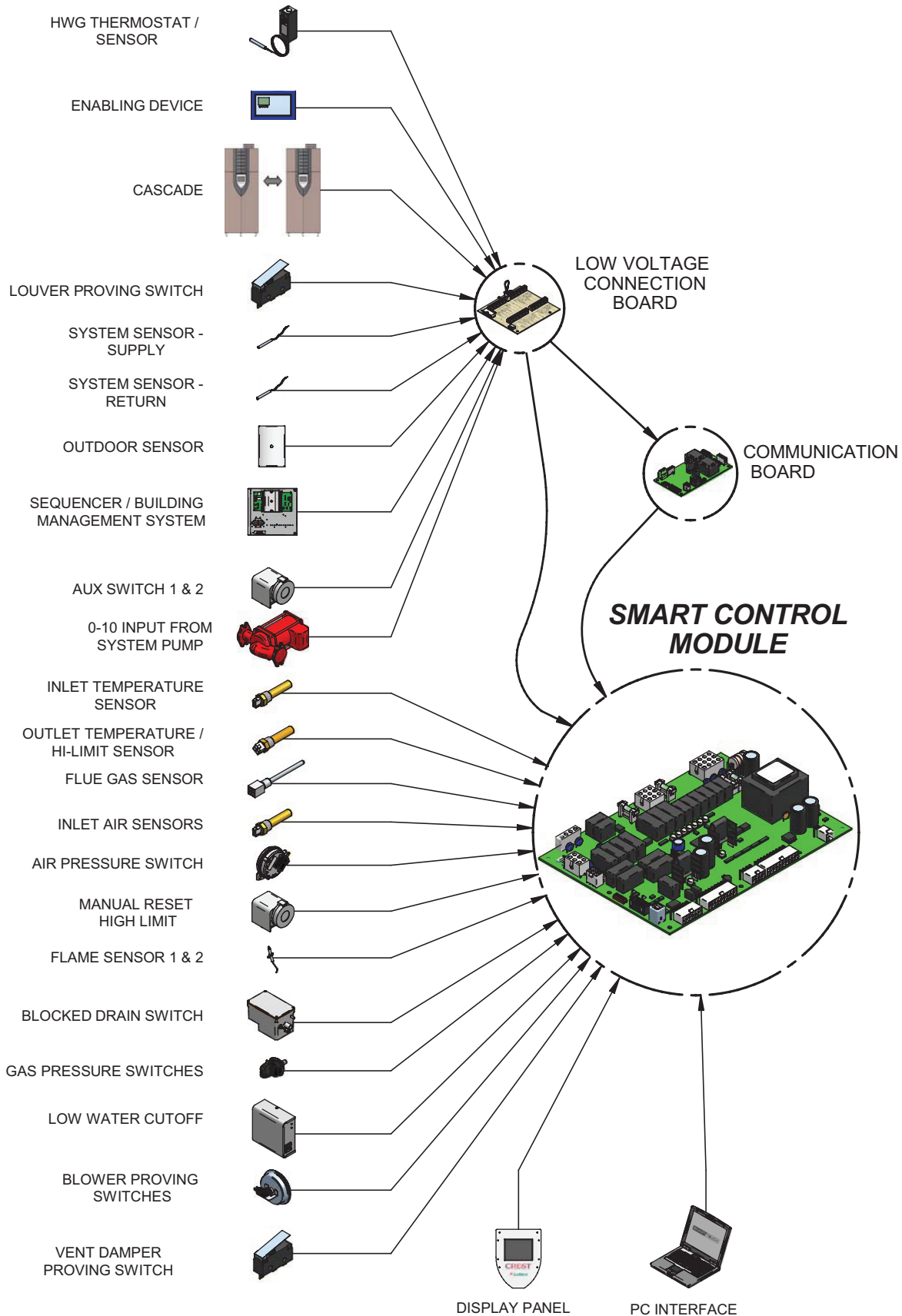

6 Wiring Requirements *(continued)*

Figure 6-3A Crest - Control Outputs

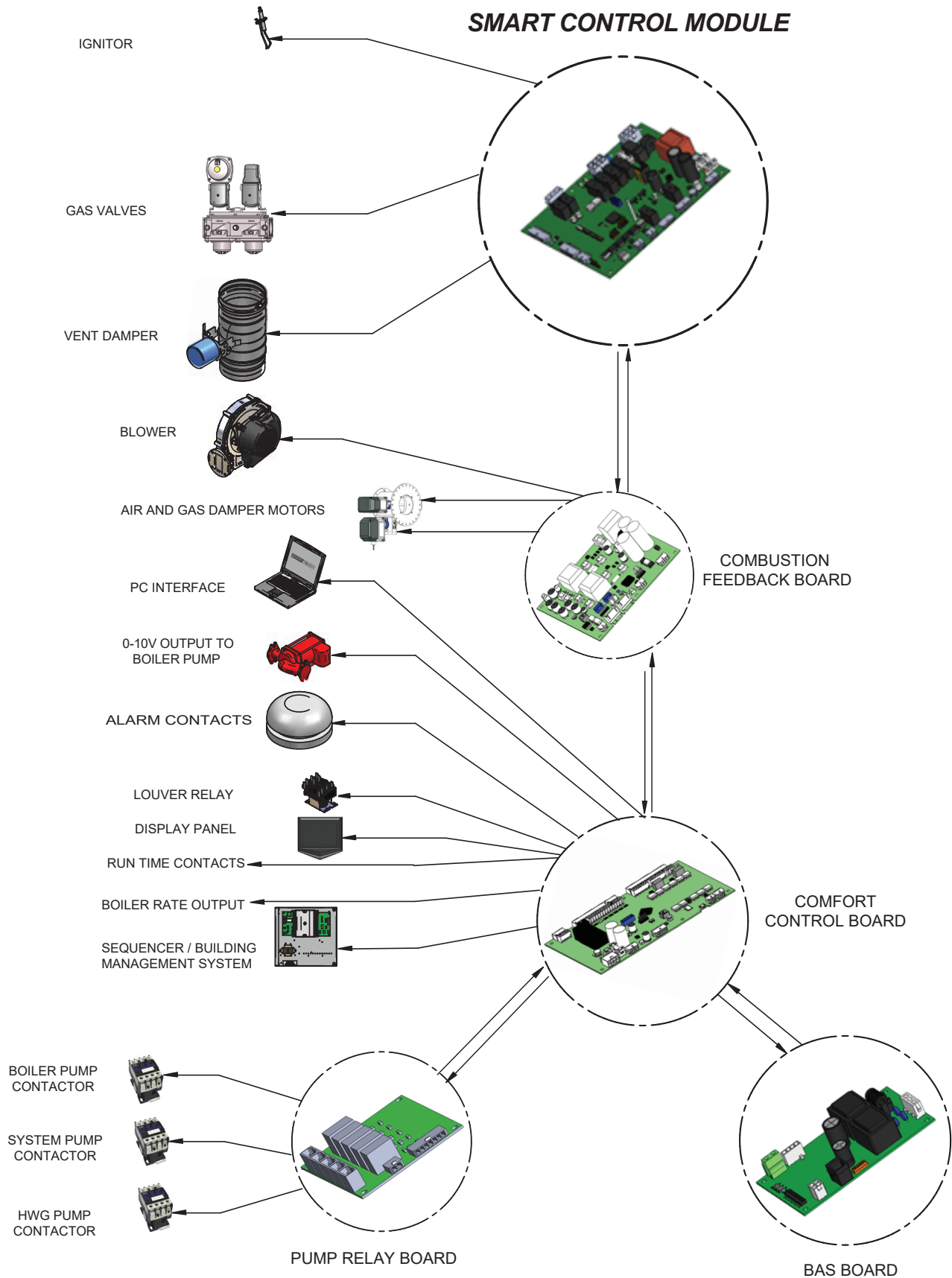

6 Wiring Requirements *(continued)*

Figure 6-3B Hellcat - Control Outputs

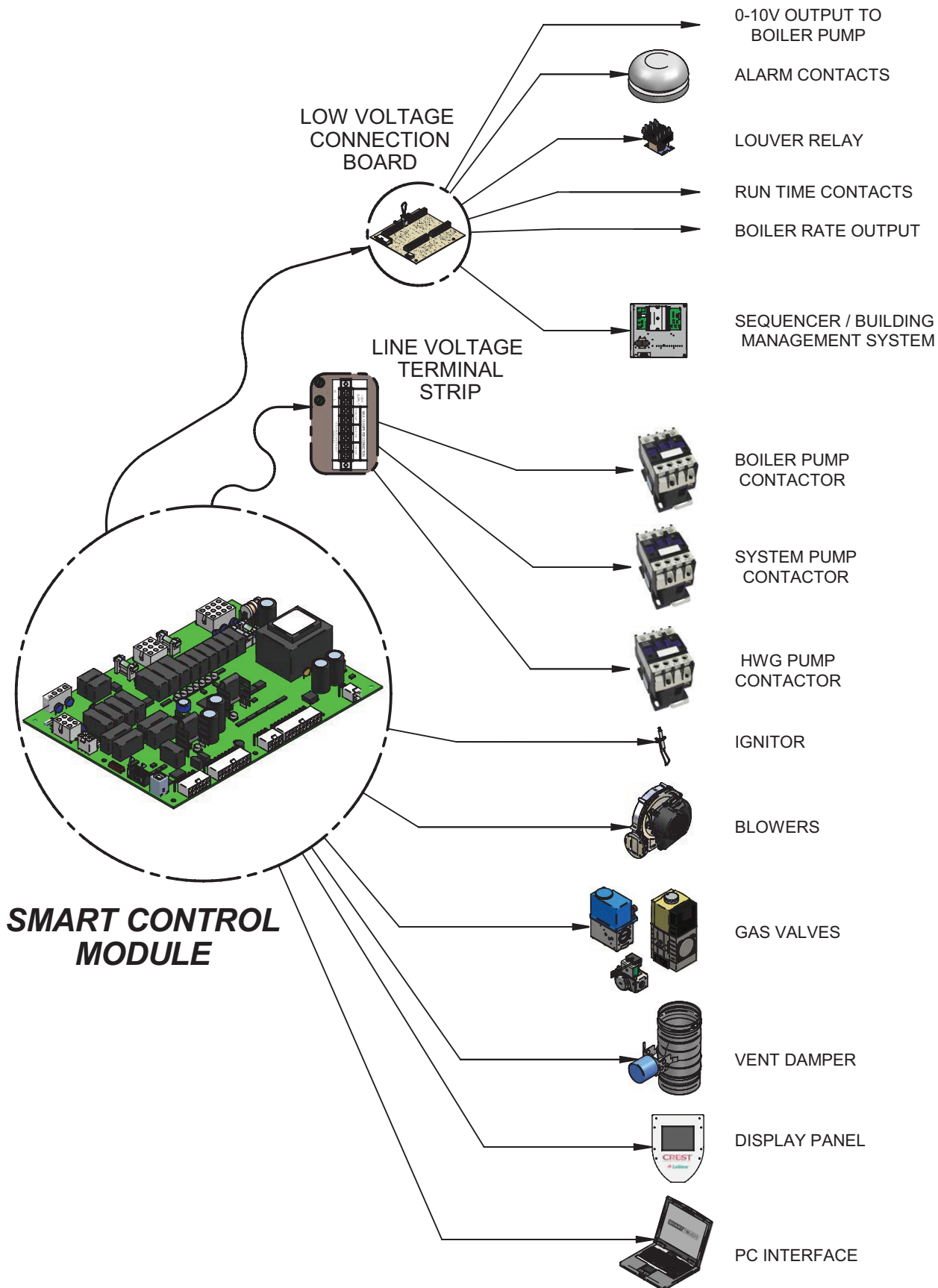

6 Wiring Requirements

Figure 6-4A Crest - Control Location

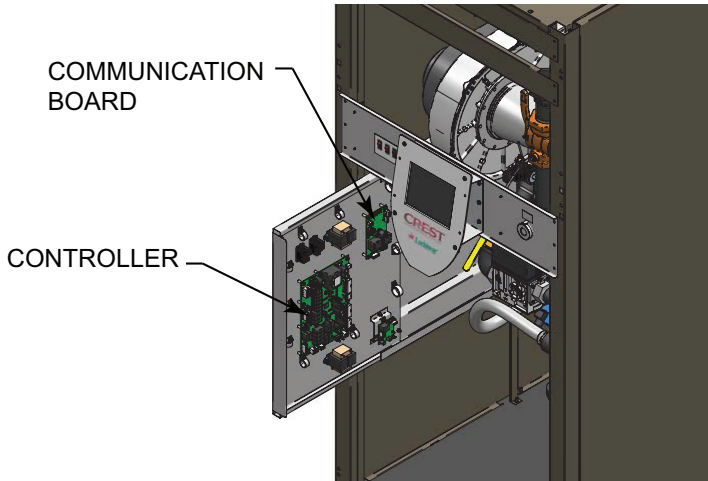
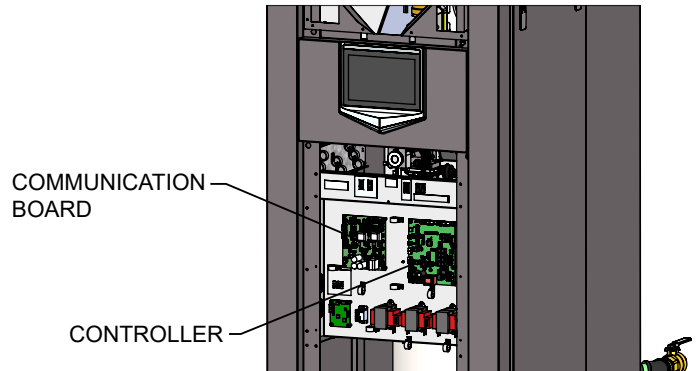

Figure 6-4B Hellcat - Control Location



2000621209 00

Typical Boiler System Wiring

Physical Configuration: Cascade without Individual Monitoring

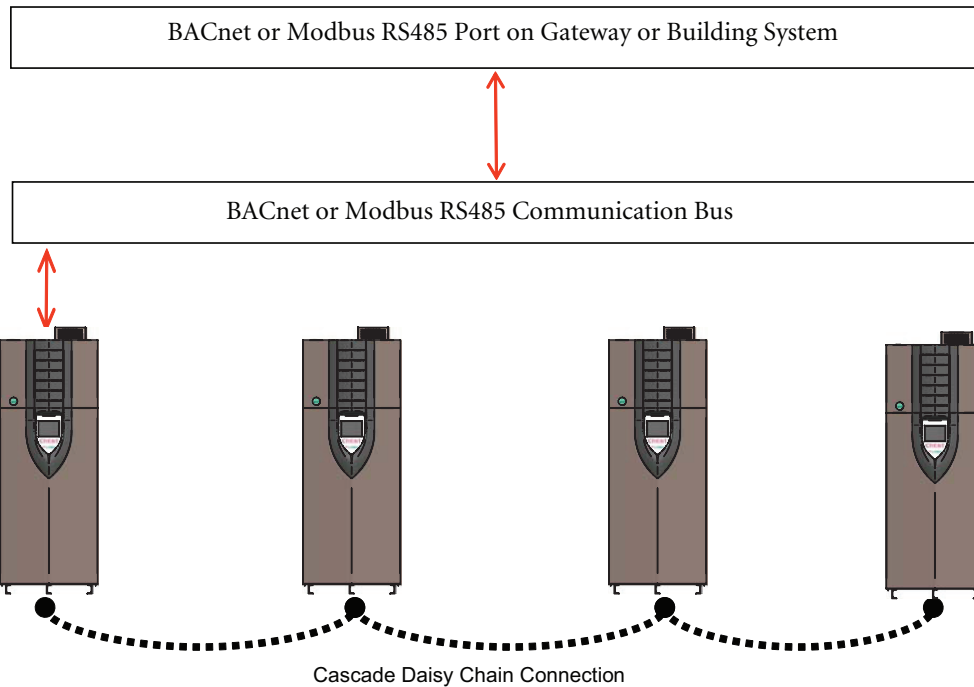

6 Wiring Requirements *(continued)*

Physical Configuration: Cascade with individual Monitoring

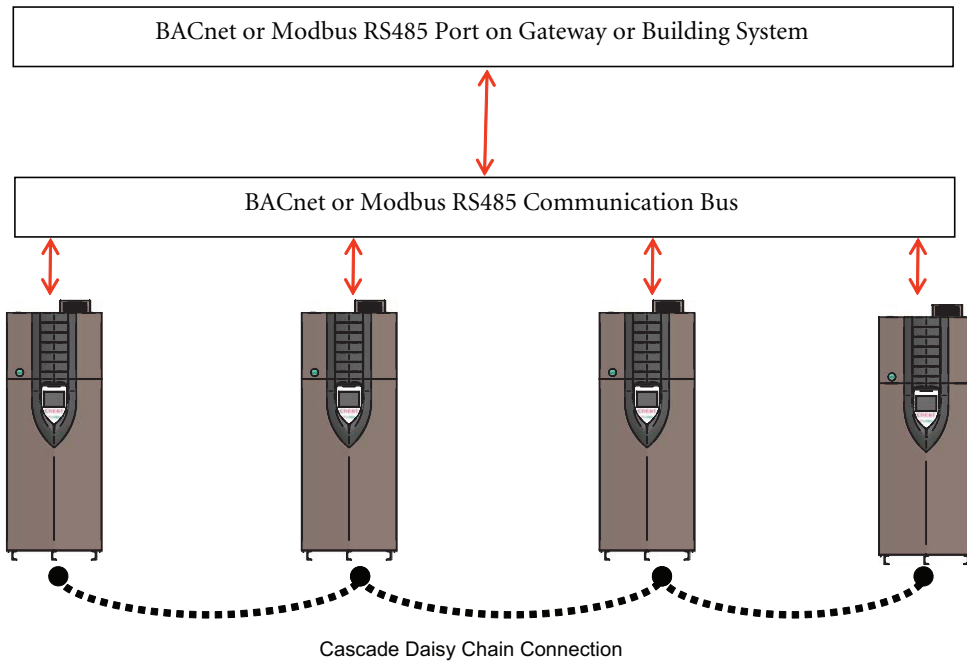

Physical Configuration: Direct Control

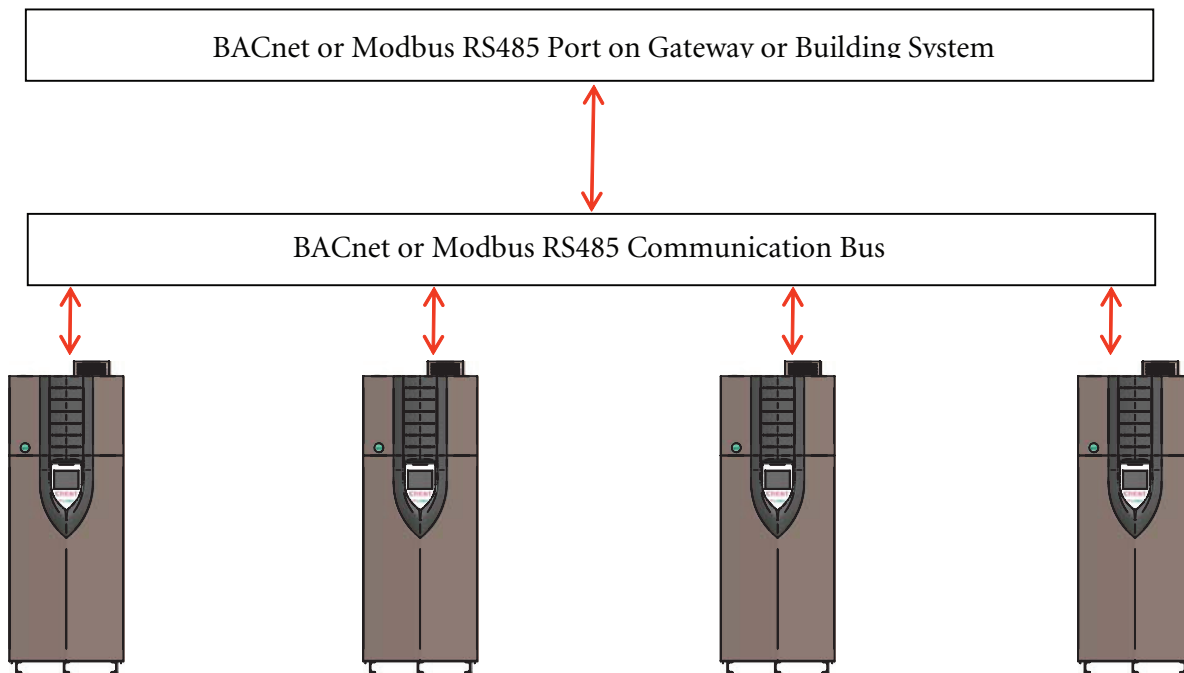

7 Unit Operation

Unit Operation with ModBus / BACnet Communications

To control a Crest boiler through a Building Management System communicating through ModBus or BACnet, the Crest Demand Configuration must be set to one of three options. These configurations allow different control points for a variety of applications. The configuration can be set by selecting Main Menu>>Setup>>BMS.

The Crest boiler is equipped with a ModBus communication timer. This timer is programmable from 0 - 120 seconds. The timer can be programmed from the ModBus Setup Menu by selecting Main Menu>>Setup>>ModBus. The purpose of the timer is to ensure proper temperature data is communicated to the boiler in a timely manner. Additionally, it will provide for fail safe operation should ModBus communication be lost. This timer will cause the unit to revert back to internal unit controls should the ModBus communication be interrupted longer than the ModBus timer. The timer is reset every time a ModBus write command is received with updated temperatures or commands. It is the recommendation of Lochinvar that this timer be set to the shortest value possible.

When controlling a Crest boiler through a Building Automation System (BAS), it is very important to ensure that the correct configuration bits are sent to holding register 40001 or Object AV0, and that the correct data and enable signals are sent to holding registers 40002 - 40007 or Objects AV1 - AV6, per the demand configuration.

Demand Configuration: ENABLE = ACTIVE; BMS = INACTIVE

In this configuration the unit is controlled by setting the setpoints locally on the boiler and providing an enable signal through ModBus or BACnet communications.

All sensors and limiting devices should be hardwired to the terminal strip on the back of the unit excluding the enable signal. This signal will be sent to the unit via ModBus.

The holding registers will need to be set as follows:

Object	Holding Registers	Definition	Bit Value (HEX)	Action
AV0	40001	Configuration	00 01	Set Configuration to read 40002
AV1	40002	Coils	00 01	Enables unit (00 00 disables unit)

NOTE: To ensure proper operation re-send the configuration bits to holding register 40001 or Object AV0 prior to issuing a command.

7 Unit Operation *(continued)*

Demand Configuration: ENABLE = ACTIVE; BMS = ACTIVE

In this configuration the unit is controlled by providing an enable signal. The setpoint command will be determined by the parameters in the control and a rate command through ModBus or BACnet communications.

The rate command will be 0 - 100% of modulation.

All sensors and limiting devices should be hardwired to the terminal strip on the back of the unit excluding the enable and 0-10V BMS signal. These signals will be sent to the unit via ModBus or BACnet.

The holding registers will need to be set as follows:

Object	Holding Registers	Definition	Bit Value (HEX)	Action
AV0	40001	Configuration	00 05	Set Configuration to read 40002 & 3
AV1	40002	Coils	00 01	Enables unit (<i>00 00 disables unit</i>)
AV2	40003	Rate Command	00 ##	Sets Modulation % or Setpoint

NOTE: To ensure proper operation re-send the configuration bits to holding register 40001 or Object AV0 prior to issuing a command.

For proper hexadecimal conversion of rate percentage, please refer to the Rate and Temperature Conversion section on page 17 of this manual.

Demand Configuration: ENABLE = INACTIVE; BMS = ACTIVE

In this configuration the unit is controlled by setting the modulation setpoint from 0 - 100%, or the setpoint. The setpoint command will be determined by the parameters in the control.

Rate command will be 0 - 100% of the modulation range.

All sensors and limiting devices should be hardwired to the terminal strip on the back of the unit excluding the 0 - 10Vdc signal. This signal will be sent to the unit via ModBus or BACnet.

The holding registers will need to be set as follows:

Object	Holding Registers	Definition	Bit Value (HEX)	Action
AV0	40001	Configuration	00 04	Set Configuration to read 40003
AV2	40003	Rate Command	00 00	Sets Modulation % or Setpoint

NOTE: To ensure proper operation re-send the configuration bits to holding register 40001 or Object AV0 prior to issuing a command.

For proper hexadecimal conversion of rate percentage, please refer to the Rate and Temperature Conversion section on page 17 of this manual.

Hot Water Generation

Hot water generation can be accomplished with one of two methods when a Crest boiler is connected to a BAS system, DHW with direct control, and DHW with remote control.

DHW with direct control:

This is the typical installation with a hot water generator in close proximity to the boiler with the tank thermostat, or tank temperature sensor, wired to the terminal strip of the unit.

7 Unit Operation

DHW with remote control:

This installation may or may not have the hot water generator in close proximity to the boiler. Its sensors and thermostat values are only available through the ModBus or BACnet communication bus.

To ensure that the Crest boiler can properly respond to a call for hot water generation the following holding registers must be set in addition to other commands:

Object	Holding Registers	Definition	Bit Value (HEX)	Action
AV0	40001	Configuration	00 4A	Set Configuration to read 40002, 4 & 5
AV1	40002	Coils	00 08	Enables Tank Tstat (<i>00 00 disables unit</i>)
AV3	40004	Tank Setpoint	0# ##	Sets Setpoint
AV4	40005	Tank Temperature	0# ##	Passes tank temp from remote sensor

NOTE: To ensure proper operation re-send the configuration bits to holding register 40001 or Object AV0 prior to issuing a command.

For proper hexadecimal conversion of rate percentage, please refer to the Rate and Temperature Conversion section on page 17 of this manual.

Cascade

In order to operate the Crest boiler in Cascade with ModBus / BACnet communications, configure the leader boiler per the demand configurations in this manual. Connect the remaining boilers in the cascade through the normal cascade communications wiring. Cascade control can then be accomplished automatically through the leader boiler.

Please note that with ModBus / BACnet communication connected to only the leader boiler, total Cascade information can be seen through the communications link. If you wish to see all the individual temperatures of each unit in the Cascade, each unit will have to have a communication board. However, each unit can be monitored without the need to control each one individually.

Monitoring Only

All Crest boilers are equipped with the communication board and can be set up to operate with its own internal controls. If necessary, ModBus / BACnet can be configured as a monitoring device by polling the communication board for the read only variables.

7 Unit Operation *(continued)*

Rate and Temperature Conversions:

Rate

When issuing a rate command the rate can be communicated as percent modulation or a desired setpoint, depending on the setting of the BMS Type in the BMS Setup Menu.

The proper data format for the modulation percentage is the direct conversion to hexadecimal. This conversion can be accomplished through online number based converters or some scientific calculators.

For Example:

Rate %	HEX
0	00
20	14
45	2D
60	3C
80	50
95	5F
100	64

To send a desired setpoint, the hexadecimal value must be determined through linear interpolation of programmable parameters on the BMS Setup Menu:

- BMS temperature set-point at low analog input
- BMS temperature set-point at high analog input

These variables set the temperature values corresponding to the minimum and maximum voltage settings of the 0-10 volt signal. The defaults are as follows:

PARAMETER	DEFAULT VALUES		DEFAULT
	Deg C	Deg F	Voltages
BMS temperature setpoint at low analog input	21	69.8	2
BMS temperature setpoint at high analog input	82	179.6	10

For Example:

Send a setpoint of 110°F.

The formula to use for the interpolation is:

Rate Command =

$$\frac{(\text{Desired Setpoint} - \text{BMS Temp at Low Analog Input}) (\text{High Voltage} - \text{Low Voltage}) + \text{Low Voltage}}{(\text{BMS Temp at High Analog Input} - \text{BMS Temp at Low Analog Input})}$$

From the default values:

Desired Setpoint = 110
 BMS Temp at Low Analog Input = 68
 BMS Temp at High Analog = 158
 High Voltage = 10
 Low Voltage = 2

$$[(110 - 68.8)(10 - 2) / (179.6 - 68.8)] + 2 = 4.92 \text{ Volts}$$

$$(4.92 / 10) \times 100 = 49.2$$

49 = 31 Hexadecimal

A value of [00][31] in hexadecimal would be written to Holding register 40003 to issue a command for a 110°F setpoint.

Temperature

The Crest boiler passes temperature data in degrees Celsius. Also, to accommodate decimal places the decimal value must be divided by 10.

Here are the conversions to and from Celsius:

$$T_c = (5/9) * (T_f - 32) \quad T_f = (9/5) * T_c + 32$$

Example:

Outdoor temperature from remote sensor on BAS System = 80°F

$$80^\circ\text{F} = 26.7^\circ\text{C}$$

Data that needs to be transmitted is $26.7 * 10 = 267$

Decimal	Binary	HEX
267	100001011	10B

Outlet temperature from unit sensor = 155°F

$$155^\circ\text{F} = 68.3^\circ\text{C}$$

Data transmitted from unit in HEX = 2AB = 683

$$683 \div 10 = 68.3 (\text{°C})$$

Decimal	Binary	HEX
683	1010101011	2AB

8 Troubleshooting

Should you encounter problems communicating over ModBus, the following items should be checked in this order:

1. Physical Layer
2. Communications Configuration and Port Settings
3. ModBus Error Codes
4. Unit Status / Blocking / Lockout Codes

Physical Layer

1. Check that all components have power (Boiler, Gateway, BAS Master)
2. Check all wire lengths. Are any drops too long?
3. Check proper shield grounding
4. Check A, B terminal connections
5. Check for Terminating Resistors (120 ohms)
6. Check for broken wires

Communications

1. Check Dip Switch Configuration of MTR-01 Board
2. Check Baud Rate (9600, 19200)
3. Check Parity
4. Check Slave ID
5. Check Port Setting on Master, Gateway, and Computers

ModBus Error Codes

1. Check ModBus communication for error codes (see page 6 for ModBus Exception Codes)
2. Check ModBus PDU
3. Check Slave ID
4. Check ModBus Command
5. Check Configuration bits for Holding Register 40001
6. Check Commands and data for Holding Registers 40002 - 40007

Unit Status Codes

See Codes in this section

Boiler Status

The Crest boiler displays a boiler state code on the Building Screen to help aid in troubleshooting. The boiler state indicates what the boiler is actually doing. This state should be compared to the command issued and what is expected. If the boiler state does not agree with the command issued, check communication and configuration.

Status Codes (Input Register 30014 or Analog Input AI13)

- 2 = Heat Demand blocked due to high absolute outlet temperature
- 3 = Heat Demand blocked due to high absolute flue temperature
- 4 = Heat Demand blocked due to high absolute Delta T (Outlet - Inlet)
- 7 = Heat Demand blocked due to changed Personality Plug
- 8 = Heat Demand blocked due to Low 24 VAC
- 9 = Outdoor shutdown
- 10 = Block due to switch OFF boiler (ON/OFF of Display)
- 12 = Block due to line frequency
- 16 = Service function
- 19 = DHW function Storage Tank
- 21 = SH function Heat demand from Room Thermostat
- 22 = SH function Heat demand from Boiler Management System
- 23 = SH function Heat demand from Cascade
- 30 = Heat demand activated by Freeze Protection
- 32 = DHW Pump Delay
- 33 = SH Pump Delay
- 34 = No heat function (after pump delay)
- 40 = Lockout

Blocking Codes (Input Register 30015 or Analog Input AI14)

- 0 = No blocking
- 5 = Blocking Due to Low 24 VAC Supply
- 6 = Blocking MRHL is open
- 8 = Blocking due to Switched OFF boiler (Display ENTER switch)
- 10 = Blocking due to High Delta T
- 14 = Blocking due to line frequency
- 15 = Blocking due to high flue temperature
- 11 = Blocking due to high outlet water temperature
- 12 = Blocking due to anti-cycling time
- 13 = Blocking due to changed ID Plug
- 7 = Blocking due to high outdoor temperature

8 Troubleshooting *(continued)*

Lockout Codes Description (Input Register 30016 or Analog Input AI15)

NOTICE

The lockout code (Input Register 30016) is constantly changing during operation and should not be used for lockout notification until the status code (Input Register 30014) indicates a code of 40.

5	=	Analog to Digital converter input had changed too quickly
7	=	Rapid Temperature Change on Pre-Mix Sensor 2 (S14)
8	=	Rapid Temperature Change on Pre-Mix Sensor 1 (S13)
9	=	Rapid Temperature Change on Pre-Mix Sensor 2 (S12)
10	=	Rapid Temperature Change on Pre-Mix Sensor 1 (S11)
11	=	Analog to Digital converter input is changed too quickly
12	=	Rapid Temperature Change on Flue Sensor (S10)
13	=	Rapid Temperature Change on Outlet Sensor (S9)
15	=	Rapid Temperature Change on System Return Sensor (S7)
16	=	Rapid Temperature Change on System Supply Sensor (S6)
17	=	Rapid Temperature Change on Tank Sensor (S4)
18	=	Rapid Temperature Change on Flue Sensor (S3)
19	=	Rapid Temperature Change on Inlet Sensor (S2)
20	=	Rapid Temperature Change on Outlet Sensor (S1)
25	=	Pre-Mix Sensor 2 (S14)-Short
26	=	Pre-Mix Sensor 1 (S13)-Short
27	=	Pre-Mix Sensor 2 (S12)-Short
28	=	Pre-Mix Sensor 1 (S11)-Short
29	=	Flue Sensor (S10)-Short
30	=	Outlet Sensor (S9) – Short
32	=	System Return Temperature Sensor (S7) – Short
33	=	System Supply Temperature Sensor (S6) – Short
34	=	Tank Sensor (S4) – Short
35	=	Flue Sensor (S3) – Short
36	=	Inlet Sensor – Short
37	=	Outlet Sensor (S1) – Short
38	=	Temperature Measurement Error 2
39	=	Temperature Measurement Error 1
45	=	High temperature differential between S12 and S14
46	=	High temperature differential between S11 and S13
48	=	High temperature differential between S3 and S10
49	=	High temperature differential between S1 and S9
50	=	Internal Error
129	=	Large Pre-Mix Temperature High
130	=	Small Pre-Mix Temperature High
134	=	Louvers Not Open
135	=	Louvers Not Closed
137	=	Large Blower Proving Switch Not Closed
139	=	Large Blower Proving Switch Not Open
140	=	Small Blower Proving Switch Not Open
145	=	Large Blower Proving Switch Not Closed
146	=	Small Blower Proving Switch Not Closed
148	=	Large Blower Proving Switch Not Open
149	=	Air Metering Valve Not Closed / Large Fan Speed Too Low
150	=	Air Metering Valve Not Open / Large Fan Speed Too High
163	=	Wrong Personality Plug
164	=	Flame Current Circuit Failed
166	=	Auto Reset High Limit
167	=	Blocked Drain Switch Open
169	=	Gas Pressure Switch Open

8 Troubleshooting

Lockout Codes Description (Input Register 30016 or Analog Input AI15)

NOTICE

The lockout code (Input Register 30016) is constantly changing during operation and should not be used for lockout notification until the status code (Input Register 30014) indicates a code of 40.

170	=	Low Water Cut-Off Open
177	=	Flue Sensor Short
178	=	Flue Sensor Open
179	=	Inlet Sensor Short
180	=	Inlet Sensor Open
192	=	Outlet Sensor Short
193	=	Outlet Sensor Open
201	=	Internal Error
204	=	Internal Error
205	=	Parameters Programmed
206	=	Error while programming Parameters
207	=	Internal Error
228	=	Pre-Mix Sensors Temperature Differential Too High
229	=	Transition Flame / Flame Failure 2
230	=	Fan / Small Fan Speed Low
231	=	Fan / Small Fan Speed High
232	=	Flame Failure 1
233	=	Ignition Failure
235	=	Flue Damper / Small Blower Proving Switch Not Open
236	=	Flue Damper / Small Blower Proving Switch Not Closed
238	=	Air Pressure Switch Open
239	=	Main Flame / Flame 1 Out of Sequence
240	=	External Manual Reset High Limit
241	=	Transition Flame / Flame 2 Out of Sequence
243	=	Transition Gas Valve Relay Failure
244	=	Large Gas Valve Relay Failure
245	=	Small Gas Valve Relay Failure
246	=	Internal Manual Reset High Limit
247	=	High Flue Temperature
253	=	High Combustion Air Temperature
254	=	Display Fault

8 Troubleshooting *(continued)*

Installation / Replacement Procedure

1. Turn OFF the main electrical power to the appliance.
2. Turn OFF the main manual gas shutoff to the appliance.
3. Unplug the three (3) wire harnesses on the communication board (see FIG. 8-1).
4. Unscrew the four (4) mounting nuts on the communication board and set aside. Remove the communication board (see FIG. 8-2).
5. Replace / install the new communication board.
6. Replace the four (4) mounting nuts removed in Step 4.
7. Reconnect all three (3) wire harnesses unplugged in Step 3.
8. Turn on the main electrical power and the main manual gas shutoff to the appliance.
9. Configure the communication board and unit controls per this manual and resume operation.

Figure 8-1_Communication Board

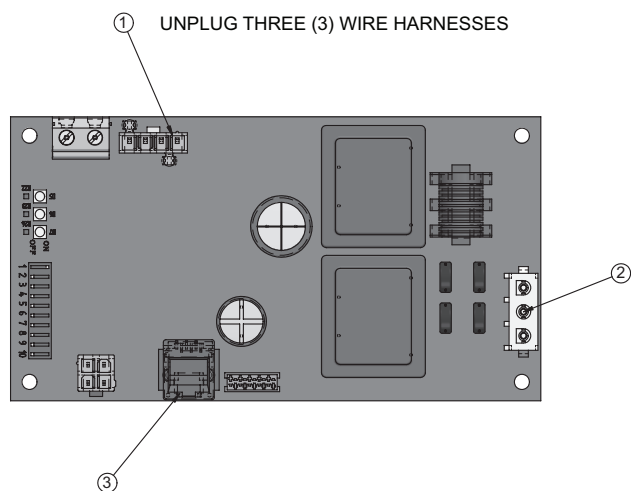

Figure 8-2_Control Panel Communication Board

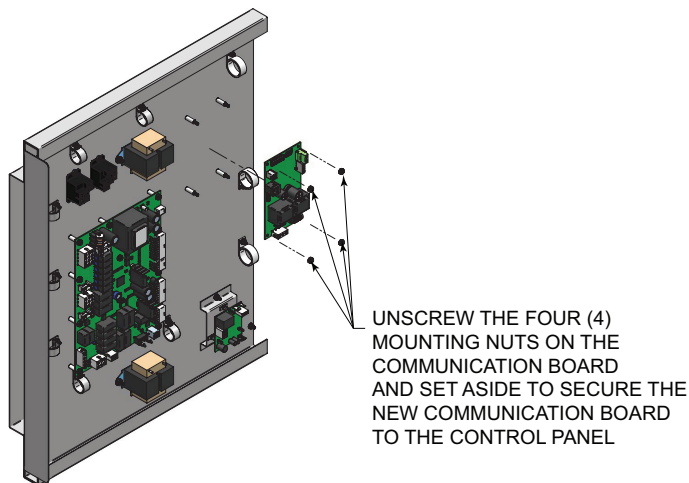
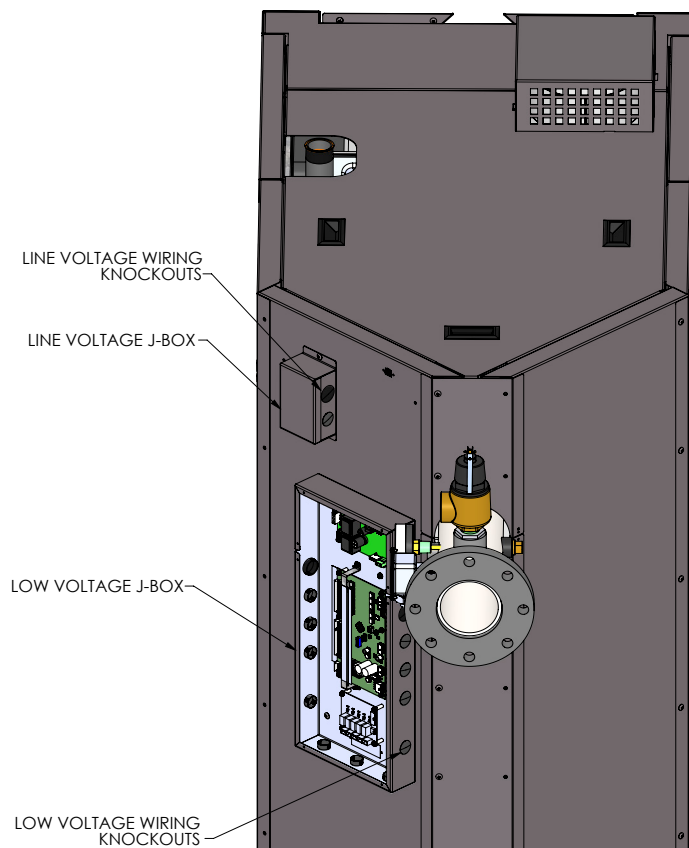

Figure 8-3 Hellcat - Routing Field Wiring



2000588412 00

Notes

Notes

Revision Notes: Revision A (ECO #C08179) initial release.

Revision B (ECO C08542) reflects edits made (pages 7, 8 and 18) due to changes made by SIT.

Revision C (ECO C10325) reflects the addition of version 4, software update (page 8).

Revision D (ECO C10391) reflects the update of ladder and wiring diagrams on pages 22 and 23.

Revision E (ECO C11613) reflects the addition of the lockout code notice on page 19 (R05772) and the addition of models 4.0 and 5.0.

Revision F (ECO C17106) reflects the addition of models .75 - 1.25.

Revision G (ECO C17530) reflects the addition of BACnet information (sections and images).

Revision H (Change #500001029) reflects the removal of the Wiring and Ladder Diagrams.

Revision J (PCP #3000003566 / CN #500003622) reflects the addition of the 6.0 Btu Model.

Revision K (PCP# 3000007541 / CN# 500007580) reflects the addition of references to A+ and B- on page 13.

Revision L (PCP# 3000008406 / CN# 500008361) reflects an update to the addressing information of BACnet configuration on page 9.

Revision M (PCP# 3000025102 / CN# 500014948) reflects the addition of Models 2501 - 6001.

Revision N (PCP #3000045243 / CN #500032780) reflects Fahrenheit and Celsius enhancement additions on page 9.

Revision P (PCP #3000052880 / CN #500039780) reflects an update to the analog values on page 12 and the object IDs on page 19.

Revision R (PCP #3000053857 / CN #500040433) reflects the addition of FCB1000-6000.

100161012_2000020084_Rev R
01/23