

# CREST<sup>®</sup>

CONDENSING BOILER

Dual Fuel Supplemental Manual  
Models: FBD 751 - 6001  
Series: 102 & 112

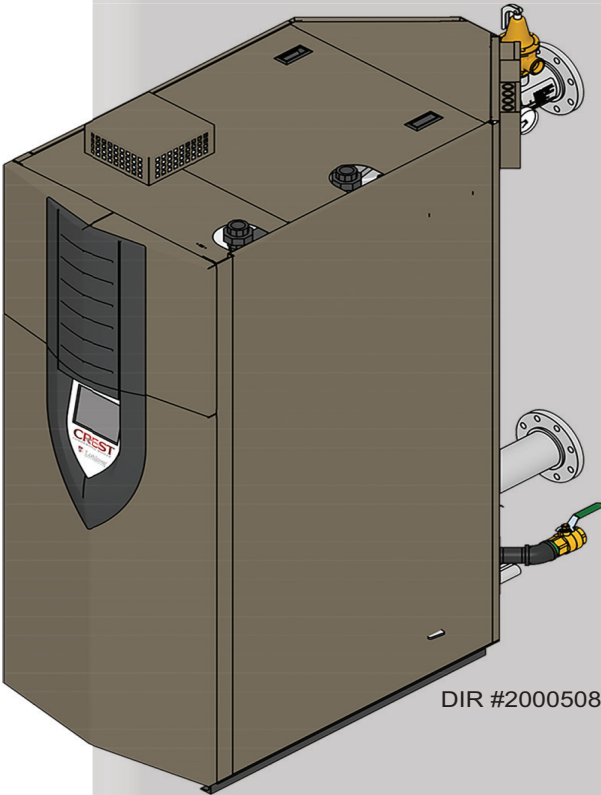

DIR #2000508187



**⚠ WARNING**

This manual must only be used by a qualified heating installer / service technician. Read all instructions, including this manual along with the Crest Installation and Operation Manual, and the Crest Service Manual, before installing. Perform steps in the order given. Failure to comply could result in severe personal injury, death, or substantial property damage.

Save this manual for future reference.



**Lochinvar<sup>®</sup>**  
HIGH EFFICIENCY BOILERS & WATER HEATERS

# CONTENTS

<b>HAZARD DEFINITIONS</b> .....	2	<b>2. START-UP</b>	
<b>PLEASE READ BEFORE PROCEEDING</b> .....	3	Start the Boiler .....	8
<b>THE CREST -- HOW IT WORKS</b> .....	4	Check System and Boiler.....	8
<b>RATINGS</b> .....	5	Operating Instructions .....	9
<b>1. GAS CONNECTIONS</b>		Check Flame and Combustion.....	10
Check Inlet Gas Supply .....	6	Dual Fuel Switching Instructions .....	10-11
Gas Pressure .....	7	<b>3. DIAGRAMS</b> .....	<b>12-19</b>
Gas Valve Replacement .....	7	Revision Notes .....	Back Cover

---

## Hazard definitions

The following defined terms are used throughout this manual to bring attention to the presence of hazards of various risk levels or to important information concerning the life of the product.

 **DANGER** DANGER indicates an imminently hazardous situation which, if not avoided, will result in death or serious injury.

 **WARNING** WARNING indicates a potentially hazardous situation which, if not avoided, could result in death or serious injury.

 **CAUTION** CAUTION indicates a potentially hazardous situation which, if not avoided, may result in minor or moderate injury.

**CAUTION** CAUTION used without the safety alert symbol indicates a potentially hazardous situation which, if not avoided, may result in property damage.

**NOTICE** NOTICE indicates special instructions on installation, operation, or maintenance that are important but not related to personal injury or property damage.

## Please read before proceeding

### **WARNING**

**Installer** – Read all instructions, including this manual, the Crest Installation and Operation Manual and the Crest Service Manual, before installing. Perform steps in the order given.

**User** – This manual is for use only by a qualified heating installer/service technician. Refer to the User’s Information Manual for your reference.

Have this boiler serviced/inspected by a qualified service technician, at least annually.

Failure to comply with the above could result in severe personal injury, death or substantial property damage.

### **NOTICE**

When calling or writing about the boiler – Please have the boiler model and serial number from the boiler rating plate.

Consider piping and installation when determining boiler location.

Any claims for damage or shortage in shipment must be filed immediately against the transportation company by the consignee.

Factory warranty (shipped with unit) does not apply to units improperly installed or improperly operated.

### **WARNING**

Failure to adhere to the guidelines on this page can result in severe personal injury, death, or substantial property damage.

### **WARNING**

If the information in this manual is not followed exactly, a fire or explosion may result causing property damage, personal injury or loss of life.

This appliance **MUST NOT** be installed in any location where gasoline or flammable vapors are likely to be present.

#### WHAT TO DO IF YOU SMELL GAS

- Do not try to light any appliance.
- Do not touch any electric switch; do not use any phone in your building.
- Immediately call your gas supplier from a near by phone. Follow the gas supplier’s instructions.
- If you cannot reach your gas supplier, call the fire department.
- Installation and service must be performed by a qualified installer, service agency, or the gas supplier.

#### When servicing boiler –

- To avoid electric shock, disconnect electrical supply before performing maintenance.
- To avoid severe burns, allow boiler to cool before performing maintenance.

#### Boiler operation –

- Do not block flow of combustion or ventilation air to the boiler.
- Should overheating occur or gas supply fail to shut off, do not turn off or disconnect electrical supply to circulator. Instead, shut off the gas supply at a location external to the appliance.
- Do not use this boiler if any part has been under water. The possible damage to a flooded appliance can be extensive and present numerous safety hazards. Any appliance that has been under water must be replaced.

# The Crest Dual Fuel - How it works...

**1. Propane gas connection**

The propane gas connection pipe is a threaded black iron pipe connection. This pipe should be connected to the incoming gas supply to deliver propane gas to the boiler.

**2. Natural gas connection**

The natural gas connection pipe is a threaded black iron pipe connection. This pipe should be connected to the incoming gas supply to deliver natural gas to the boiler.

**3. Fuel selection switch**

Switches the unit between natural and propane gas.

**4. Natural gas indicator light (green)**

Indicates that natural gas operation has been selected.

**5. Propane gas indicator light (red)**

Indicates that propane gas operation has been selected.

**6. Small natural gas valve (Valve 1 Natural)**

The small natural gas valve senses the negative pressure created by the blowers, allowing gas to flow only if the gas valves are powered and combustion air is flowing.

**7. Small propane valve (Valve 1 Propane)**

The small propane gas valve senses the negative pressure created by the blowers, allowing gas to flow only if the gas valves are powered and combustion air is flowing.

**8. Large natural gas valve (Valve 2 Natural)**

The large natural gas valve senses the negative pressure created by the blowers, allowing gas to flow only if the gas valves are powered and combustion air is flowing.

**9. Large propane gas valve (Valve 2 Propane)**

The large propane gas valve senses the negative pressure created by the blowers, allowing gas to flow only if the gas valves are powered and combustion air is flowing.

**10. Natural shutoff valve**

The natural shutoff valve is used to isolate the boiler gas train from the gas supply.

**11. Propane shutoff valve**

The propane shutoff valve is used to isolate the boiler gas train from the gas supply.

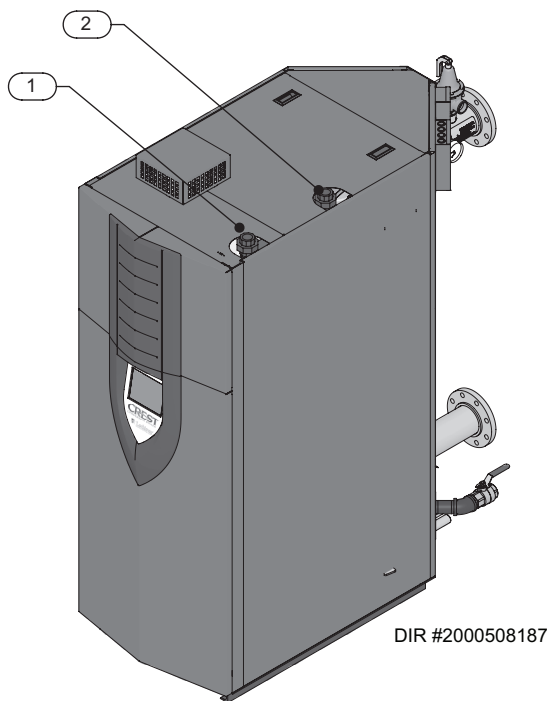

Front View

Series 102

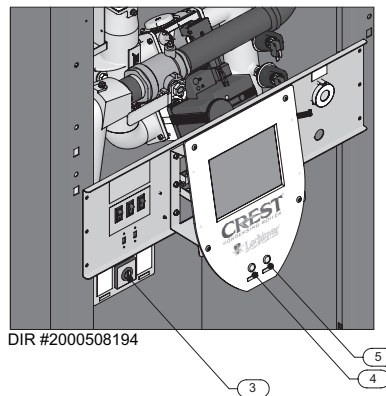

Series 112

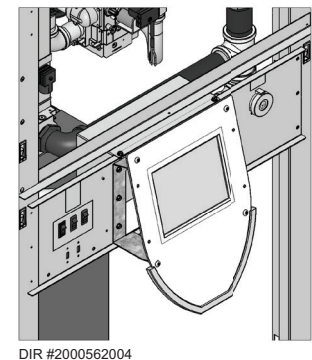

Series 102

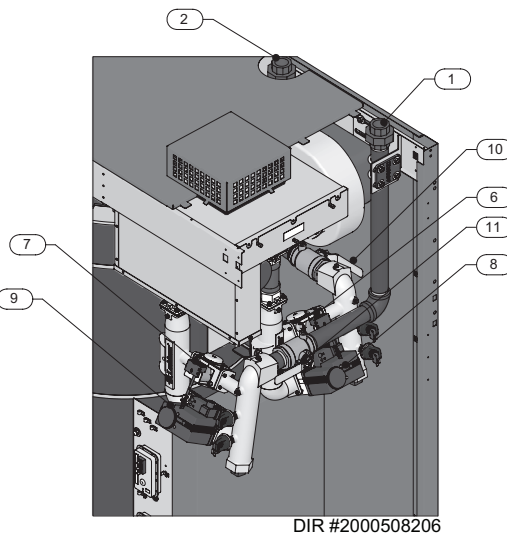

Series 112

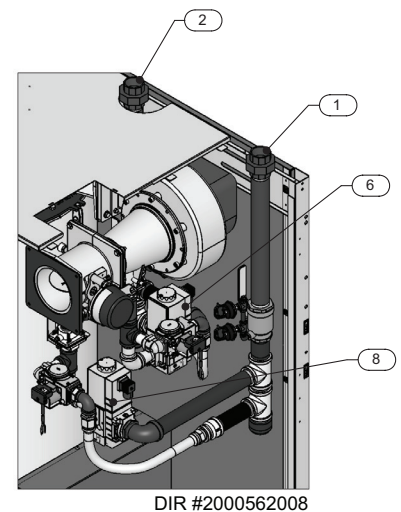

Left Side (inside unit)

# Ratings



 Crest AHRI Rating					Other Specifications						
Model Number  Note: Change "N" to "L" for L.P. gas models.	Input MBH  (Notes 4 - 6)		Gross Output MBH  (Note 1)	Net AHRI Ratings Water, MBH  (Note 2)	Appliance Water Content Gallons	Pipe Size Outlet	Pipe Size Inlet	Gas Inlet Size	Air Size	Vent Size  (Note 3)	Weight w/Water (lbs.)
	Min	Max									
FB(N,L,D)0751	50	750	721	626	73	3"	3"	1 1/4"	6"	6"	1768
FB(N,L,D)1001	50	999	961	834	77	3"	3"	1 1/4"	6"	6"	1838
FB(N,L,D)1251	62.5	1250	1203	1043	87	3"	3"	1 1/2"	6"	8"	1975
FB(N,L,D)1501	60	1500	1443	1252	94	4"	4"	1 1/2"	8"	8"	2307
FB(N,L,D)1751	70	1750	1684	1461	106	4"	4"	1 1/2"	8"	8"	2458
FB(N,L,D)2001	80	1999	1923	1699	111	4"	4"	1 1/2"	8"	8"	2570
FB(N,L,D)2501	125	2500	2400	2087	157	4"	4"	2"	8"	9"	3600
FB(N,L,D)3001	150	3000	2883	2507	156	4"	4"	2"	10"	10"	3900
FB(N,L,D)3501	175	3500	3364	2925	202	4"	4"	2"	10"	10"	4600
FB(N,L,D)4001	333.3	3999	3843	3342	201	4"	4"	2 1/2"	12"	12"	5200
FB(N,L,D)5001	499.9	4999	4804	4177	254	6"	6"	2 1/2"	14"	14"	5900
FB(N,L,D)6001	600	6000	5766	5014	304	6"	6"	3"	14"	14"	6900

**NOTICE**

Maximum allowed working pressure is located on the rating plate.

**Notes:**

1. The ratings are based on standard test procedures prescribed by the United States Department of Energy.
2. Net AHRI ratings are based on net installed radiation of sufficient quantity for the requirements of the building and nothing need be added for normal piping and pickup. Ratings are based on a piping and pickup allowance of 1.15.
3. Crest boilers require special gas venting. Use only the vent materials and methods specified in the Crest Installation and Operation Manual.
4. Standard Crest boilers are equipped to operate from sea level to 4,500 feet **only**. The boiler will de-rate by 1.4% for each 1,000 feet above sea level up to 4,500 feet.
5. High altitude Crest Models are equipped to operate from 3,000 to 12,000 feet **only**. The boiler will not de-rate up to 5,500 feet and will de-rate by 1.6% for each 1,000 feet above 5,500 feet. The operation given in this manual remains the same as the standard boilers. A high altitude label (as shown in FIG A.) is also affixed to the unit.

De-rate values are based on proper combustion calibration and CO<sub>2</sub>'s adjusted to the recommended levels.

6. High altitude Crest Models 4.0 and 5.0 will not de-rate up to 5,500 feet.
7. The high altitude Crest 6.0 model will de-rate by 2.0% for each 1000 feet above sea level up to 5,500 feet.
8. For Crest Models 4.0, 5.0 and 6.0, installations above 5,500 feet contact the factory.
9. Ratings have been confirmed by the Hydronics Section of AHRI.

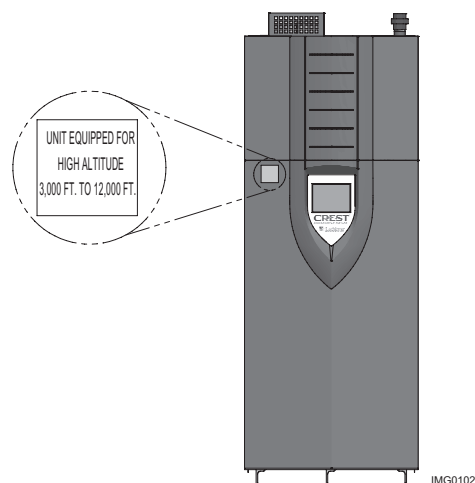

Figure A High Altitude Label Location

# 1 Gas connections

**Table 1A First Stage Piping at High Pressure\_10 PSI**

Nominal Iron Pipe Size Inches	Length of pipe or tubing, feet												
	10	20	30	40	50	60	70	80	90	100	125	150	
Maximum Capacities of Pipe in KBTUH/Hr													
	1/2	2442	1885	1580	1382	1240	1133	1048	979	921	872	775	703
Pipe	3/4	4831	3812	3230	2842	2561	2346	2175	2035	1917	1816	1618	1470
Size	1	8531	6916	5939	5270	4776	4392	4083	3829	3614	3429	3063	2789
(I.D.)	1 1/4	16626	13771	11963	10691	9736	8987	8378	7872	7443	7074	6336	5779
	1 1/2	23670	19957	17510	15749	14407	13341	12470	11740	11119	10581	9501	8682
	2	42521	36514	32398	29359	27001	25104	23538	22216	21082	20097	18104	16580
Notice: Capacities shown are for Natural Gas. Please consult supplier for proper gas pipe sizing for propane.													

**Table 1B Second Stage Piping at Low Pressure\_1/2 PSI**

Nominal Iron Pipe Size Inches	Length of pipe or tubing, feet												
	10	20	30	40	50	60	70	80	90	100	125	150	
Maximum Capacities of Pipe in KBTUH/Hr													
	1 1/4	2205	1496	1212	1039	913	834	771	724	677	630	567	511
Pipe	1 1/2	3307	2299	1858	1559	1417	1275	1181	1086	1023	976	866	787
Size	2	6221	4331	3465	2992	2646	2394	2205	2047	1921	1811	1606	1496
(I.D.)	2 1/2	10140	7046	5695	4778	4343	3908	3618	3329	3160	2991	2654	2412
	3	17990	12510	10110	8481	7708	6936	6422	5908	5608	5309	4711	4281
	4	36710	25520	20620	17300	15730	14150	13100	12050	11440	10830	9613	8736
Notice: Capacities shown are for Natural Gas. Please consult supplier for proper gas pipe sizing for propane.													

## Check inlet gas supply

**WARNING** DO NOT adjust or attempt to measure gas valve outlet pressure. Attempting to alter or measure the gas valve outlet pressure could result in damage to the valve, causing potential severe personal injury, death, or substantial property damage.

**NOTICE** The Dual Fuel Crest is equipped with two (2) inlet gas connections. Each connection must be checked to ensure proper operation.

**NOTICE** Ensure that the high gas pressure regulator is at least 10 feet (3 m) upstream of the appliance.

**NOTICE** The gas inlet size has been designed to allow the minimum of 10 feet between the boiler and regulator and for a maximum pressure drop of 1" w.c.

The gas piping must be sized for the proper flow and length of pipe, to avoid excessive pressure drop. Both the gas meter and the gas regulator must be properly sized for the total gas load.

If you experience a pressure drop greater than 1 inch w.c. (249 Pa), the meter, regulator, or gas line is undersized or in need of service. Perform the steps below when checking inlet gas supply:

1. Turn the main power switch to the "OFF" position.
2. Shut off gas supply at the manual gas valve in the gas piping to the appliance.

3. For Crest models 751-2001: Remove the 1/8" pipe plug on the gas manifold before the gas valve, and install a suitable 1/8" fitting (field supplied) for the manometer tubing. Place the tubing of the manometer over the tap once the 1/8" fitting is installed as shown in FIG. 1-1, 1-2, 1-3, and 1-4.

For Crest models 2501-6001: Remove the 1/8" pipe plug on the large gas valve flange before the gas valve, and install a suitable 1/8" fitting (field supplied) for the manometer tubing. Place the tubing of the manometer over the tap once the 1/8" fitting is installed as shown in FIG. 1-1, 1-2, 1-3, and 1-4.

4. Slowly turn on the gas supply at the factory installed manual gas valve.
5. Turn the power switch to the "ON" position.
6. Adjust the temperature set point on the control panel of the SMART TOUCH control module to call for heat or utilize Service Mode, see page 10 of this manual.
7. Observe the gas supply pressure as the burner fires at 100% of rated input. Percent of burner input will be displayed on the Modulation Screen.
8. Ensure inlet pressure is within specified range. Minimum and maximum gas supply pressures are specified in this section of the manual.
9. If gas supply pressure is within normal range and no adjustments are needed, proceed on to Step 11.

# 1 Gas connections *(continued)*

**⚠ WARNING** Do not check for gas leaks with an open flame -- use the bubble test. Failure to use the bubble test or check for gas leaks can cause severe personal injury, death, or substantial property damage.

10. If the gas pressure is out of range, contact the gas utility, gas supplier, qualified installer, or service agency to determine the necessary steps to provide proper gas pressure to the control.
11. Turn the power switch to the "OFF" position.
12. Shut off the gas supply at the manual gas valve in the gas piping to the appliance.
13. Remove the manometer from the pressure tap on the gas manifold or gas valve flange, depending on model size. Remove the 1/8" (3mm) field supplied fitting and reinstall the pipe plug removed in Step 3.
14. Turn on the gas supply at the manual gas valve.
15. Turn the power switch to the "ON" position.
16. Adjust the temperature set point on the control panel of the SMART TOUCH control module to the desired water temperature so the appliance will call for heat.
17. Check burner performance by cycling the system while you observe burner response. The burner should ignite promptly. Flame pattern should be stable. Turn system off and allow burner to cool, then cycle burner again to ensure proper ignition and flame characteristics.
18. Repeat Steps 1 - 17 for both natural and LP gas supply.

Ignition problems are especially noticeable in NEW LP installations and also in empty tank situations. This can also occur when a utility company shuts off service to an area to provide maintenance to their lines.

## Gas valve replacement

The gas valve **MUST NOT** be replaced with a conventional gas valve under any circumstances. As an additional safety feature, the gas valves have flanged connections to the venturis and blowers.

**⚠ WARNING** Failure to follow all precautions could result in fire, explosion, or death!

**⚠ WARNING** DO NOT adjust or attempt to measure gas valve outlet pressure. Attempting to alter or measure the gas valve outlet pressure could result in damage to the valve, causing potential severe personal injury, death, or substantial property damage.

## Gas Pressure

The gas pressure must remain between 4 inches w.c. (.99 kPa) minimum and 14 inches w.c. (3.5 kPa) maximum for Natural gas and between 8 inches w.c. (1.99 kPa) minimum and 14 inches w.c. (3.5 kPa) maximum for LP gas during standby (static) mode and while in operating (dynamic) mode. If an in-line regulator is used, it must be a minimum of 10 feet (3 m) from the Crest boiler. It is very important that the gas line is properly purged by the gas supplier or utility company. Failure to properly purge the lines or improper line sizing, will result in ignition failure.

**Figure 1-1 Inlet Gas Supply Check\_Natural - Models 751-2001**

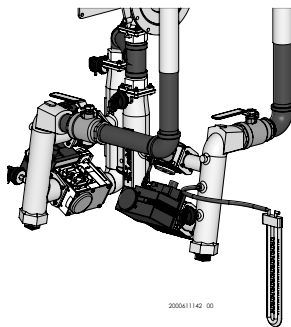

**Figure 1-2 Inlet Gas Supply Check\_Propane - Models 751-2001**

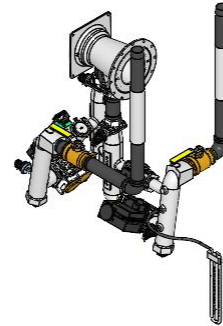

**Figure 1-3 Inlet Gas Supply Check\_Natural - Models 2501-6001**

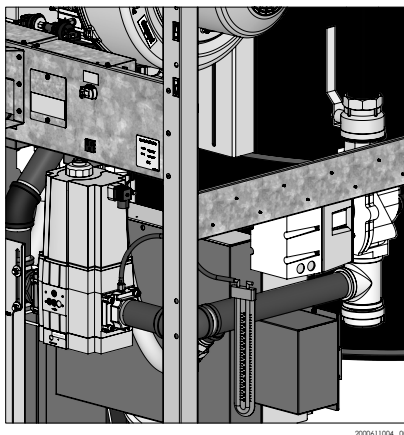

**Figure 1-4 Inlet Gas Supply Check\_Propane - Models 2501-6001**

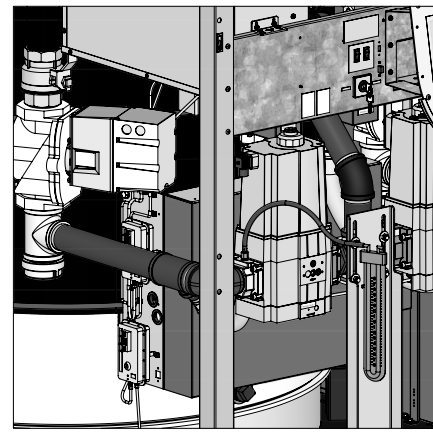

## 2 Start-up

### Final checks before starting the boiler

- ❑ Read the Crest Service Manual to familiarize yourself with SMART TOUCH control module operation. Read this manual, page 9 for proper steps to start boiler.
- ❑ Verify the boiler and system are full of water and all system components are correctly set for operation.
- ❑ Verify the preparation procedures of Section 9 of the Crest Installation and Operation Manual have been completed.
- ❑ Verify electrical connections are correct and securely attached.
- ❑ Inspect vent piping and air piping for signs of deterioration from corrosion, physical damage or sagging. Verify air piping and vent piping are intact and correctly installed per this manual.

### Start the boiler

1. Read and follow the Operating instructions in FIG. 2-1, page 9.

### If boiler does not start correctly

1. Check for loose connections, blown fuse or service switch off?
2. Is external limit control (if used) open? Is boiler water temperature above 200°F (93°C)?
3. Is the boiler receiving a call for heat?
4. Is gas turned on at meter and boiler?
5. Is incoming gas pressure less than 4 inches w.c. (.99 kPa) (NATURAL) or 8 inches w.c. (1.99 kPa) (PROPANE)?

If none of the above corrects the problem, refer to the Troubleshooting Section of the Crest Service Manual.

### Check system and boiler

#### ❑ Check water piping

1. Check system piping for leaks. If found, shut down the boiler and repair immediately. (See WARNINGS in the Crest Installation and Operation Manual (startup) regarding failure to repair leaks.)
2. Vent any remaining air from the system using manual vents. Air in the system will interfere with circulation and cause heat distribution problems and noise.

#### ❑ Check vent piping and air piping

1. Check for gastight seal at every connection, seam of air piping, and vent piping.

 **WARNING** Venting system must be sealed gastight to prevent flue gas spillage and carbon monoxide emissions, which will result in severe personal injury or death.

#### ❑ Check gas piping

1. Check around the boiler for gas odor following the procedure in the Crest Installation and Operation Manual (connecting gas supply piping).

 **WARNING** If you discover evidence of any gas leak, shut down the boiler at once. Find the leak source with a bubble test and repair immediately. Do not start the boiler again until corrected. Failure to comply could result in severe personal injury, death, or substantial property damage.

## 2 Start-up *(continued)*

Figure 2-1 Operating Instructions

### FOR YOUR SAFETY READ BEFORE OPERATING

**WARNING:** If you do not follow these instructions exactly, a fire or explosion may result causing property damage, personal injury, or loss of life.

- A. This appliance does not have a pilot. It is equipped with an ignition device which automatically lights the burner. Do not try to light the burner by hand.
  - B. BEFORE OPERATING smell all around the appliance area for gas. Be sure to smell next to the floor because some gas is heavier than air and will settle on the floor.
- WHAT TO DO IF YOU SMELL GAS**
- Do not try to light any appliance.
  - Do not touch any electric switch; do not use any phone in your building.
  - Immediately call your gas supplier from a neighbor's phone. Follow the gas supplier's instructions.
  - If you cannot reach your gas supplier, call the fire department.
- C. Use only your hand to turn the gas control knob. Never use tools. If the handle will not turn by hand, don't try to repair it, call a qualified service technician. Force or attempted repair may result in a fire or explosion.
  - D. Do not use this appliance if any part has been under water. Immediately call a qualified service technician to inspect the appliance and to replace any part of the control system and any gas control which has been under water.

### OPERATING INSTRUCTIONS

1. **STOP!** Read the safety information above on this label.
2. Set the thermostat to lowest setting.
3. Turn off all electric power to the appliance.
4. This appliance is equipped with an ignition device which automatically lights the burner. Do not try to light the burner by hand.
5. Remove front door.
6. Turn gas shutoff valve counterclockwise to "OFF". Handle will be perpendicular to pipe. Do not force.
7. Wait five (5) minutes to clear out any gas. If you then smell gas, **STOP!** Follow "B" in the safety information above this label. If you don't smell gas, go to next step.
8. Turn gas shutoff valve clockwise to "ON". Handle will be parallel to pipe.
9. Install front door.
10. Turn on all electric power to appliance.
11. Set thermostat to desired setting.
12. If the appliance will not operate, follow the instructions "To Turn Off Gas To Appliance" and call your service technician or gas supplier.

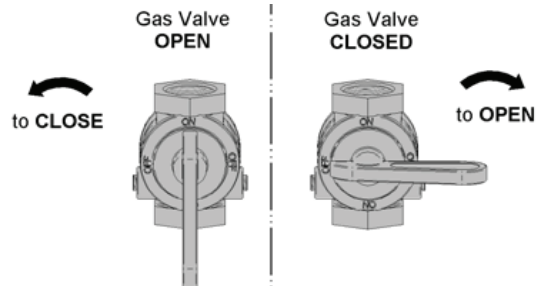

### TO TURN OFF GAS TO APPLIANCE

1. Set the thermostat to lowest setting.
2. Turn off all electric power to the appliance if service is to be performed.
3. Remove front door.
4. Turn gas shut off valve counterclockwise to "OFF". Handle will be perpendicular to pipe. Do not force.
5. Install front door.

## 2 Start-up

### Check flame and combustion

1. Turn the main power off to the boiler by placing the “On/Off” switch in the OFF position.
2. Remove the fitting from the flue collector. **Note:** Combustion measurements will be made at this point.
3. Insert the probe from a combustion analyzer into the hole left by the removal of the fitting.
4. Turn the main power on to the boiler by placing the “On/Off” switch in the ON position.
5. Navigate to the Setup Screen from the Home Screen by pressing the SETUP button along the left side of the screen. Enter the installer password.
6. Select the Service Maintenance Screen. The tabs will scroll (up and down) to reveal more options.

On the Service Maintenance Screen place heater into Service Mode by selecting the START button, then select **Set Gas Valve 1 - High**.

7. Once the boiler has modulated up to rate, measure the combustion. The values should be in the range listed in Table 2A below. CO levels should be less than 200 ppm for a properly installed unit. If the combustion is not within range reference the *Troubleshooting* Section in the Crest Service Manual for possible causes and corrective actions.

8. Once the heater analysis is complete, test the safety shutoff device by turning the manual shutoff valve to the OFF position and ensuring the heater shuts down and registers an alarm. Open the manual shutoff valve and reset the control.
9. Turn the main power off to the boiler and replace the fitting into the flue pipe connection.
10. Place the boiler back into normal operation.

**⚠ WARNING** You must replace the fitting to prevent flue gas spillage into the room. Failure to comply could result in severe personal injury, death, or substantial property damage.

### Dual fuel switching instructions

1. Turn the main power off to the boiler by placing the “On/Off” switch in the OFF position (FIG. 2-2).
2. Using the fuel selector switch (FIG. 2-2), select the desired fuel.

**Figure 2-2 Fuel Selector Switch**

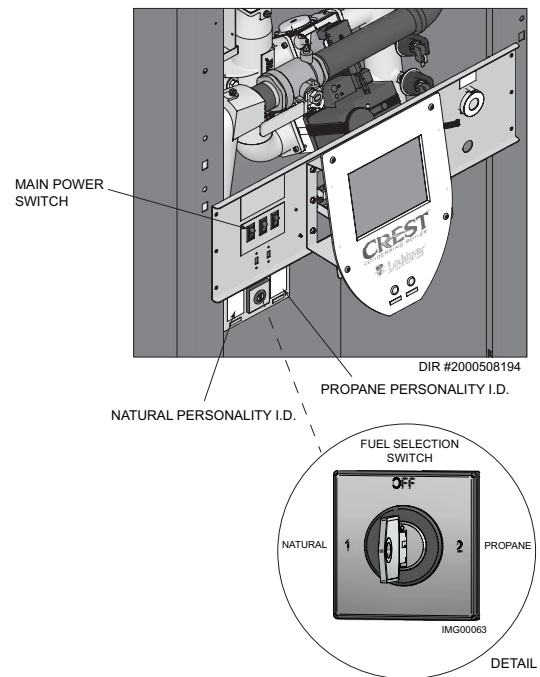

**Table 2A Flue Products Chart**

Flue Products	Natural Gas			
	751-2001		2501-6001	
Units	CO <sub>2</sub> (%)	O <sub>2</sub> (%)	CO <sub>2</sub> (%)	O <sub>2</sub> (%)
Gas Valve				
Valve 1 High	9.2	4.6	9.2	4.6
Valve 1 Low	9.0	4.9	8.5	5.7
Valve 2 High	9.3	4.4	9.5	4.2
Valve 2 Low	8.7	5.5	8.8	5.4
Propane				
Units	CO <sub>2</sub> (%)	O <sub>2</sub> (%)	CO <sub>2</sub> (%)	O <sub>2</sub> (%)
Gas Valve				
Valve 1 High	11.0	4.1	11	4.1
Valve 1 Low	10.0	5.6	9.9	5.7
Valve 2 High	11.1	4.0	11.1	4
Valve 2 Low	10.7	4.6	10.1	5.5

\*\*All set points should be within +/- 0.2%\*\*

## 2 Start-up *(continued)*

3. Turn off all shutoff valves for the fuel not in use (FIG. 2-3).
4. Turn on the shutoff valve for the one in use.
5. Turn the main power ON.
6. Using the Touch Screen, accept the appropriate personality identification as shown in FIG. 2-4.

**Figure 2-3 Shutoff Valves**

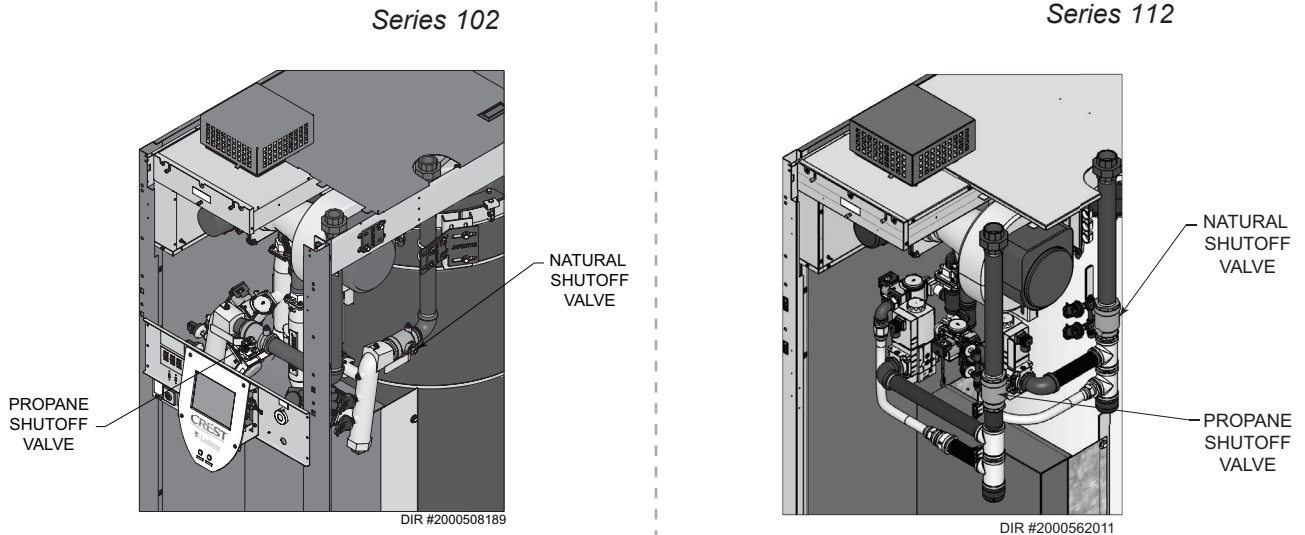

**Figure 2-4 Personality Plug**



### Personality Plug

This screen indicates that the personality plug has changed or is missing. To ensure that the correct personality plug is installed, reference the label located to the left of the display. By pressing the Accept button you are verifying that the personality plug ID# below is correct. If the wrong personality plug is accepted, the boiler will not operate properly.

Previous Personality Plug ID # 8

Current Personality Plug ID # 0



# 3 Diagrams

Figure 3-1 Ladder Diagram\_751 - 2001 Models

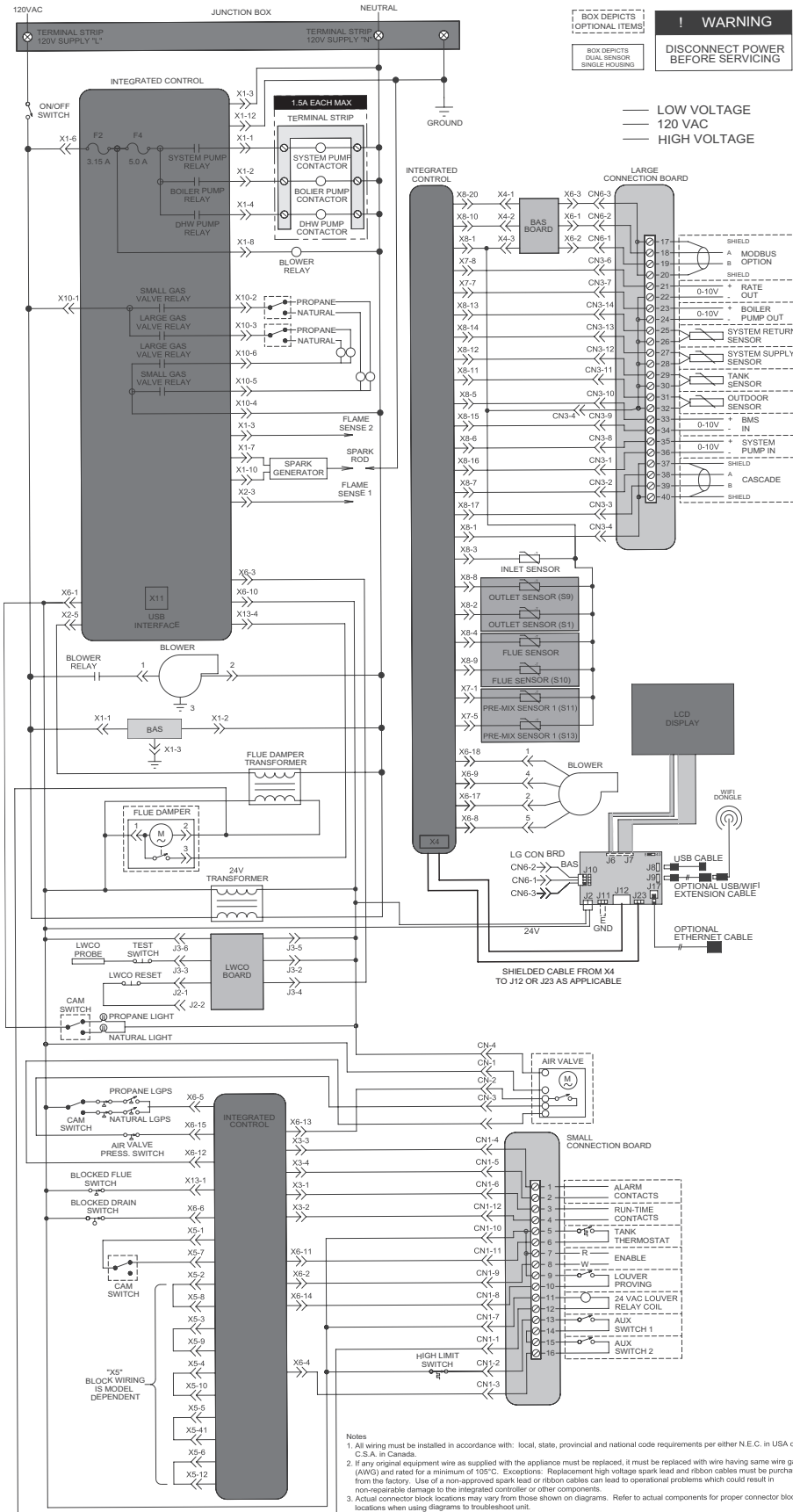



# 3 Diagrams

Figure 3-3 Ladder Diagram\_2501 - 3501 Models

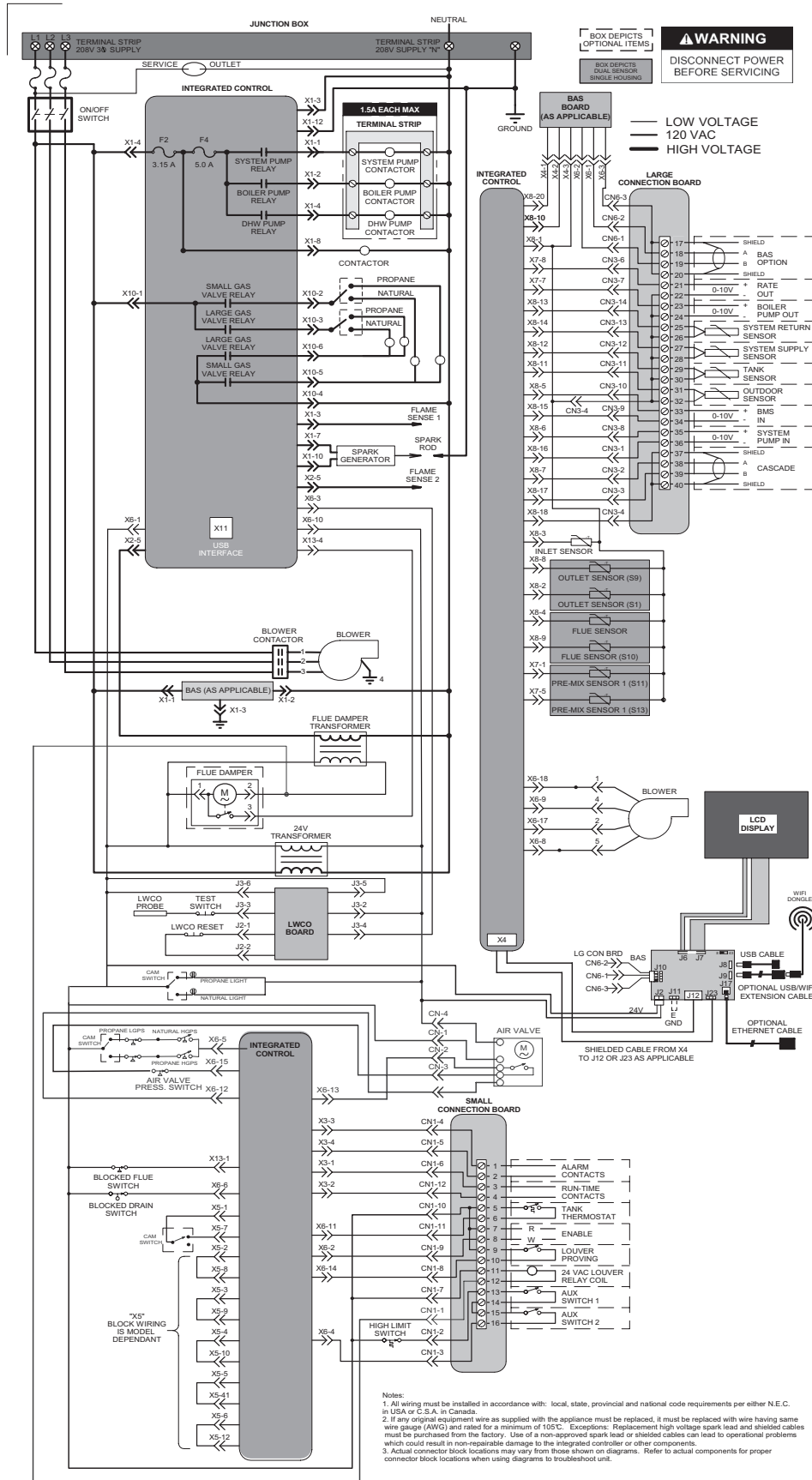

LADDER DIAGRAM  
10039296 REV A

# 3 Diagrams *(continued)*

Figure 3-4 Wiring Diagram\_2501 - 3501 Models

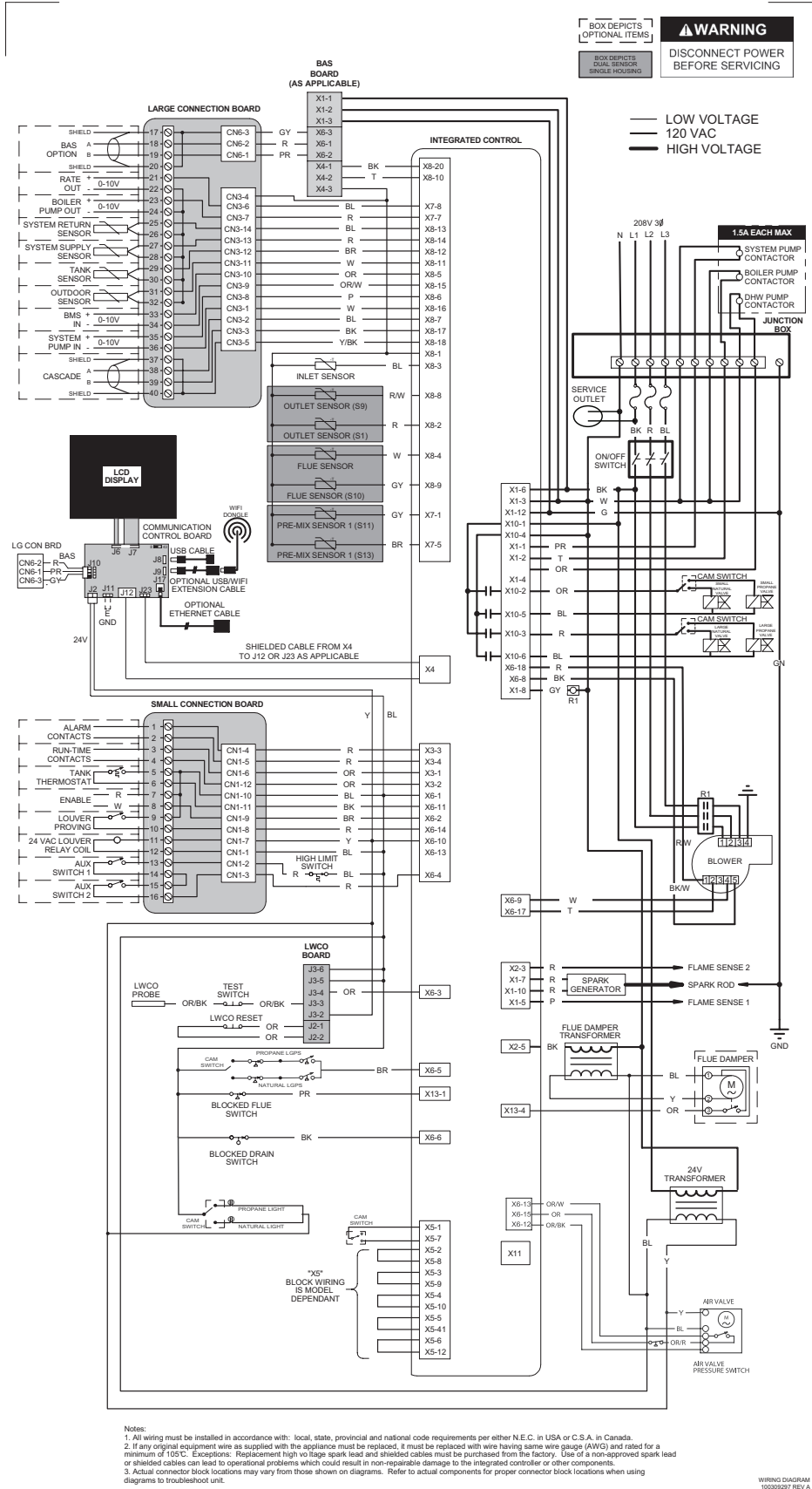

# 3 Diagrams

Figure 3-5 Ladder Diagram\_4001 - 5001 Models

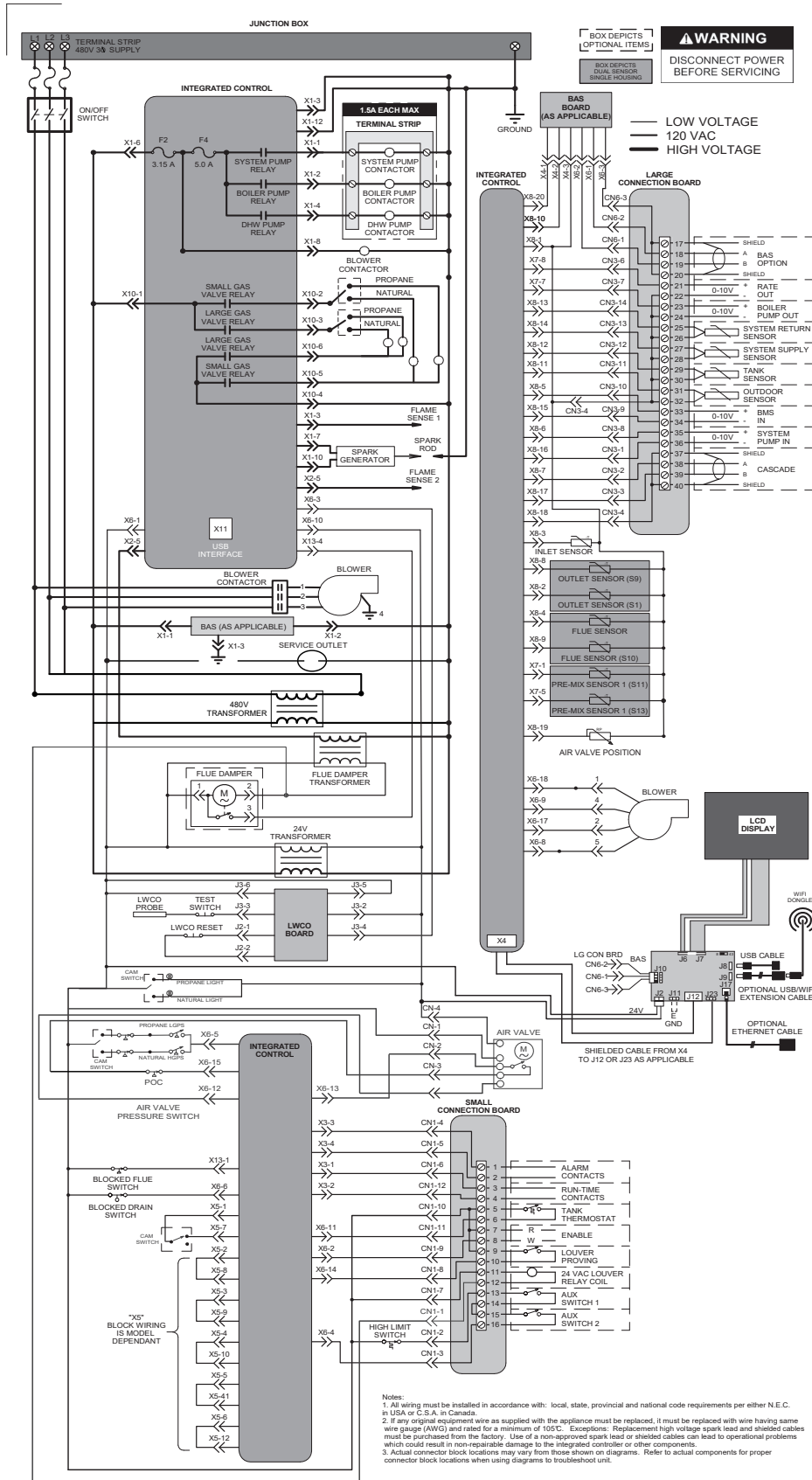

# 3 Diagrams (continued)

Figure 3-6 Wiring Diagram\_4001 - 5001 Models

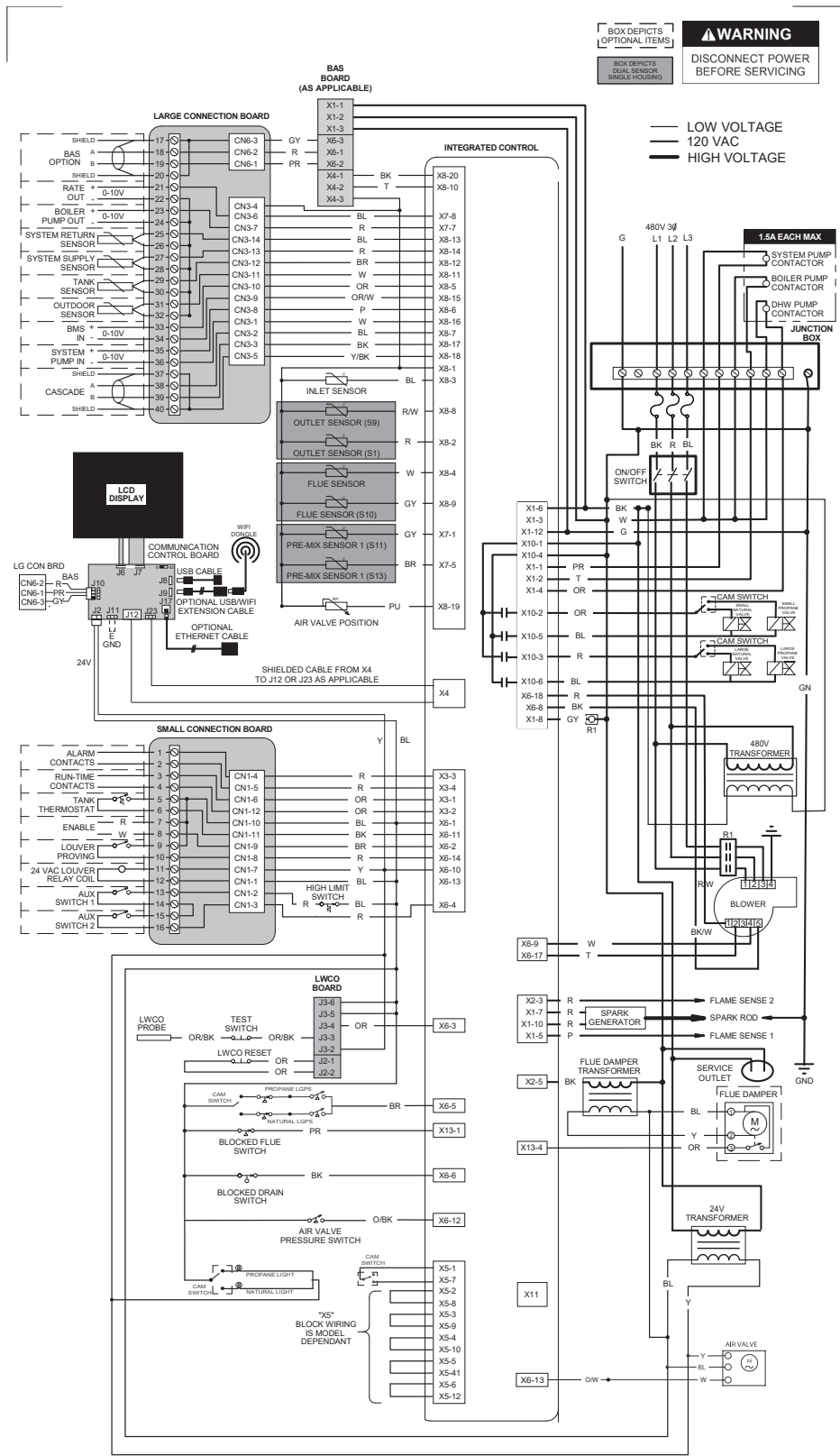

Notes:  
 1. All wiring must be installed in accordance with local, state, provincial and national code requirements per either N.E.C. in USA or C.S.A. in Canada.  
 2. If any original equipment wire as supplied with the appliance must be replaced, it must be replaced with wire having same wire gauge (AWG) and rated for a minimum of 105°C. Exceptions: Replacement high voltage spark lead and shielded cables must be purchased from the factory. Use of a non-approved spark lead or shielded cables can lead to operational problems which could result in non-repairable damage to the integrated controller or other components.  
 3. Actual connector block locations may vary from those shown on diagrams. Refer to actual components for proper connector block locations when using diagrams to troubleshoot unit.

# 3 Diagrams

Figure 3-7 Ladder Diagram\_6001 Model

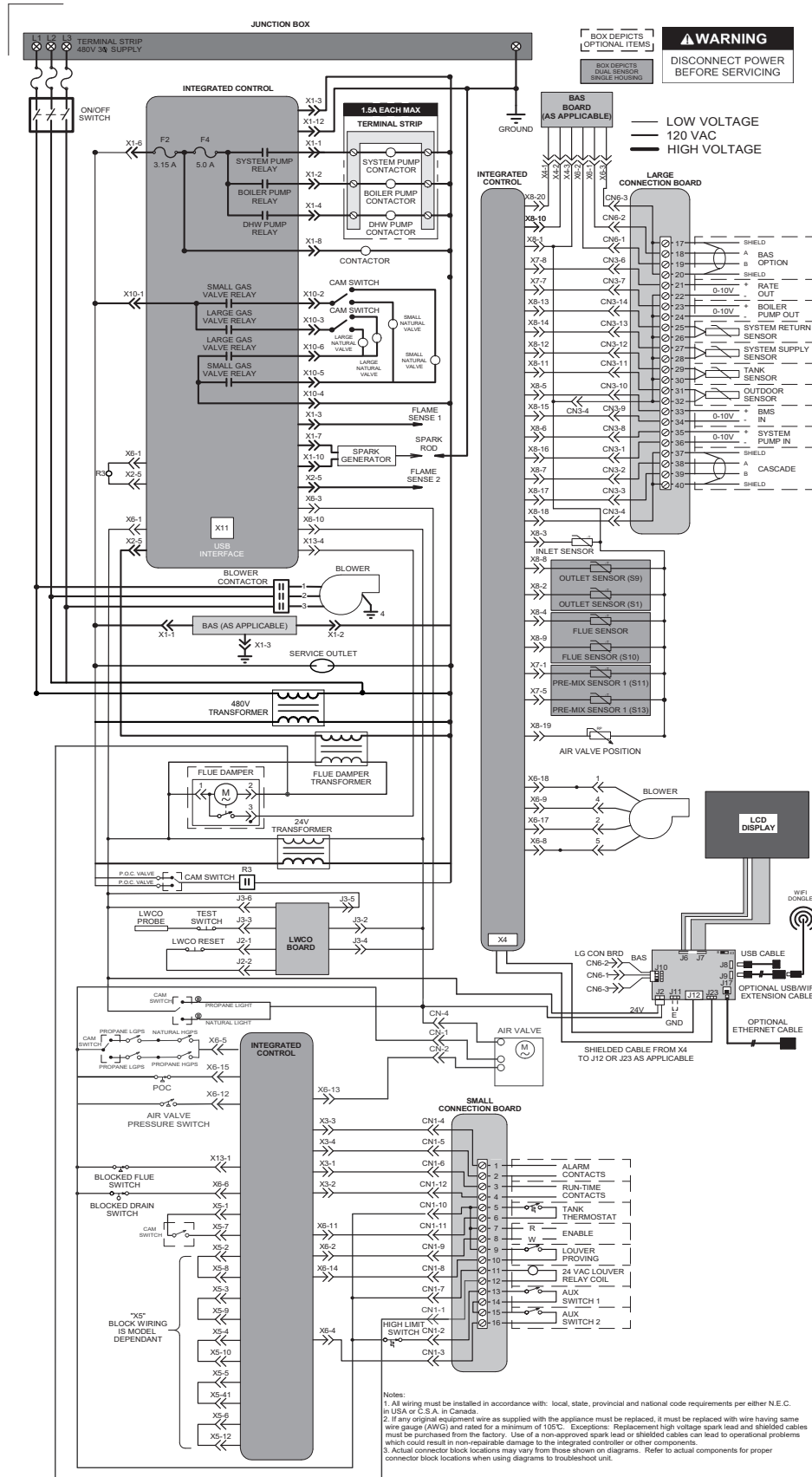

# 3 Diagrams (continued)

Figure 3-8 Wiring Diagram\_6001 Model

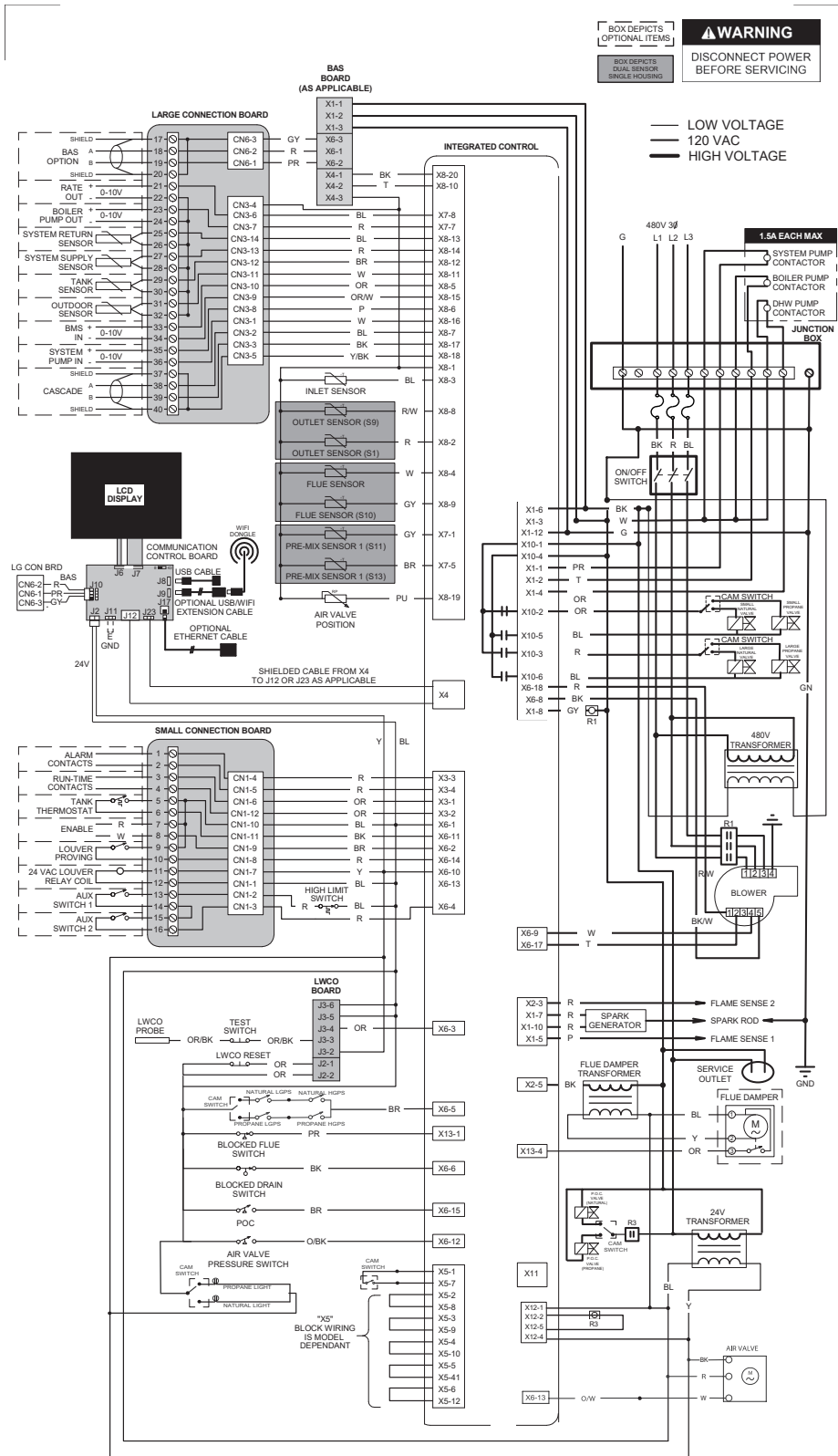

WIRING DIAGRAM  
300-0000 REV. A

**Revision Notes:** *Revision A (Change #500001029) initial release.*

*Revision B (PCP# 3000007468 / CN# 500007726) reflects the addition of the Energy Star logo.*

*Revision C (PCP# 3000027158 / CN# 500016862) reflects the addition of Models 2501 - 6001 as well as gas valve changes to series 112 that were originally on TLA #27116.*

*Revision D (PCP# 3000027116 / CN# 500016865) reflects the addition of series 112 on the front cover.*

*Revision E (PCP #3000028279 / CN #500017755) reflects an update to the Check Flame and Combustion Section on page 10, along with updates to the wiring and ladder diagrams.*

*Revision F (PCP #3000033824 / CN #500022616) reflects an update to the ratings table.*

*Revision G (PCP #3000035711 / CN #500024133) reflects an update to the Ratings Table and the addition of notices on page 6.*

*Revision H (PCP #3000040404 / CN #500028531) reflects an update to the propane minimum inlet gas pressure.*

*Revision J (PCP #3000042364 / CN #500030203) reflects updates to the wiring and ladder diagrams.*

*Revision K (PCP #3000049089 / CN #5000036206) reflects updates to the gas supply instructions on pages 6-7 and new images for FIG. 1-1 and 1-2.*