



Lochinvar[®]
HIGH EFFICIENCY BOILERS & WATER HEATERS

PARTS & SERVICE DEPARTMENT
Nashville, Tennessee
877-554-5544 • Fax: 615-882-2918
parts_team@lochinvar.com
www.Lochinvar.com

Replacement Parts List

FTXL[®]
Heating Boilers
FTX400 - 1000(N/L)

UNIT
FTX400 - 850 N/L SERIES 100 / 110

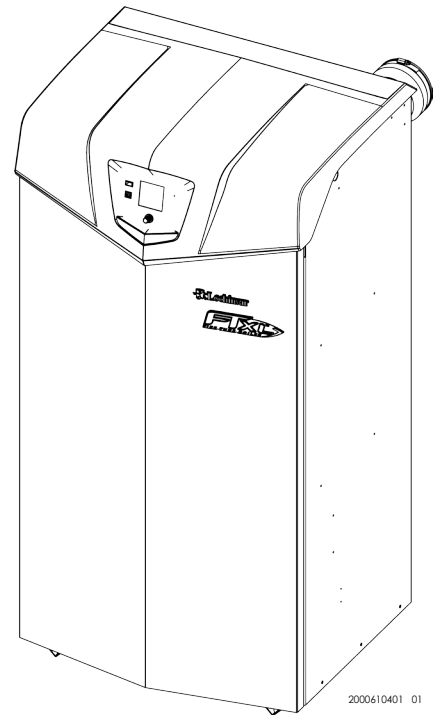
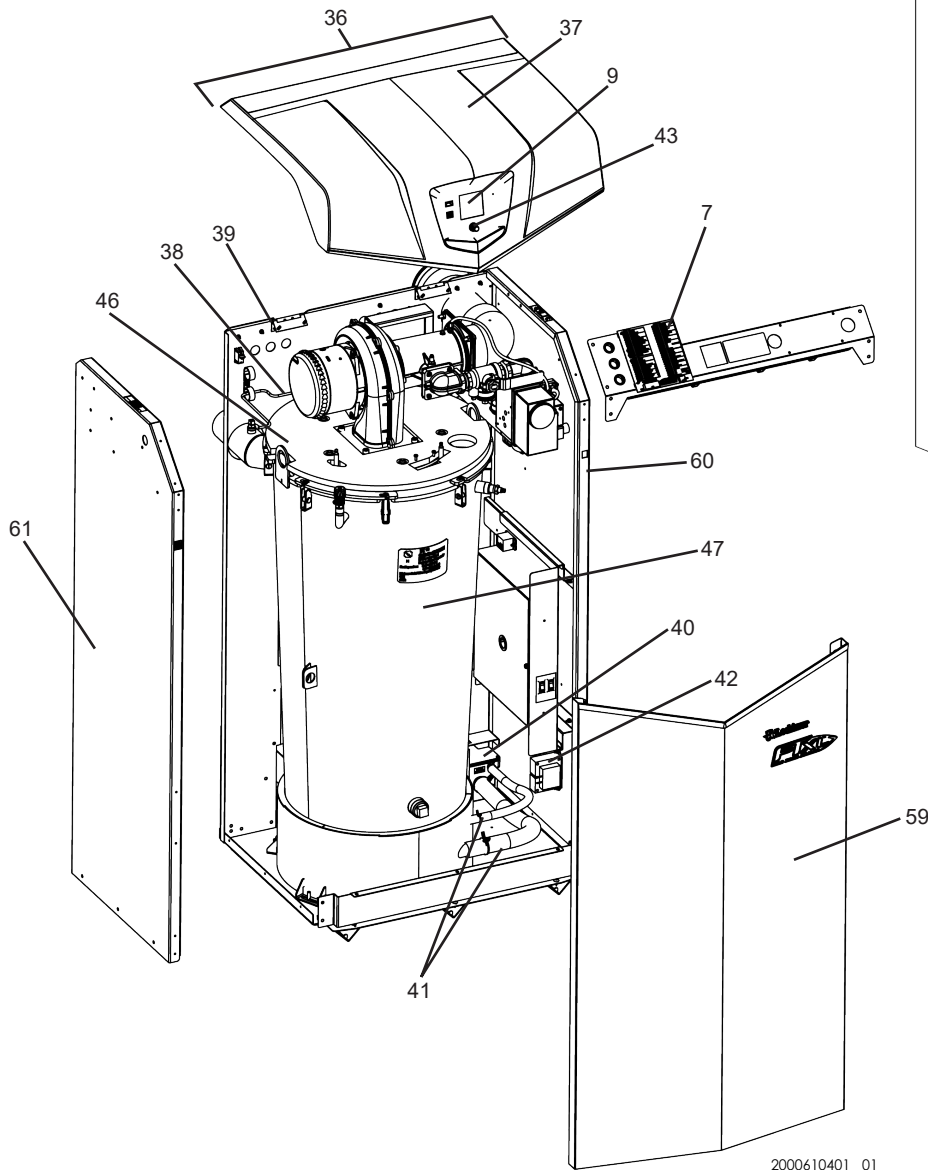

UNIT
FTX400 - 850 N/L SERIES 120
FTX1000 N/L SERIES 110

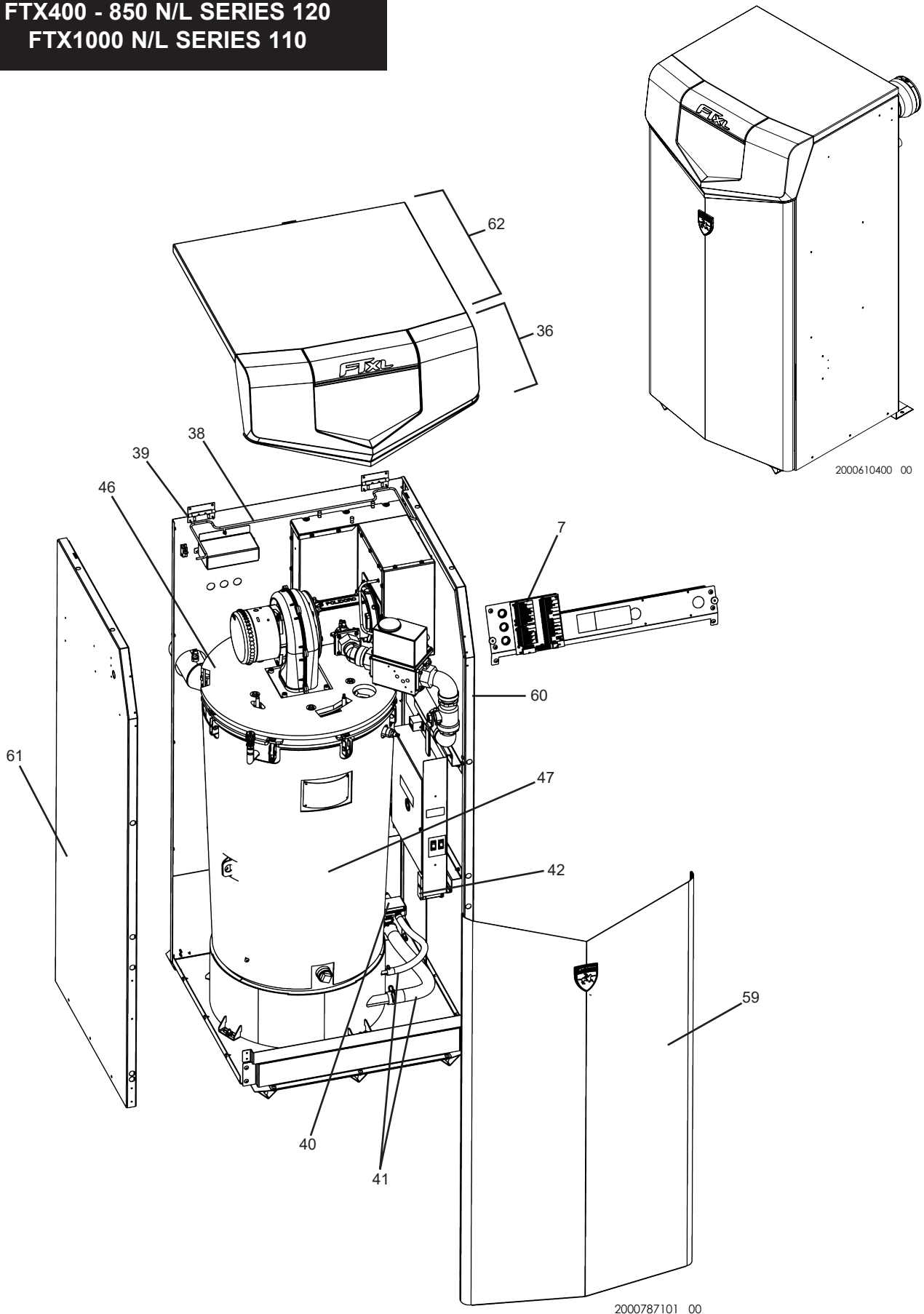

2000610400 00

2000787101 00

CONTROL PANEL

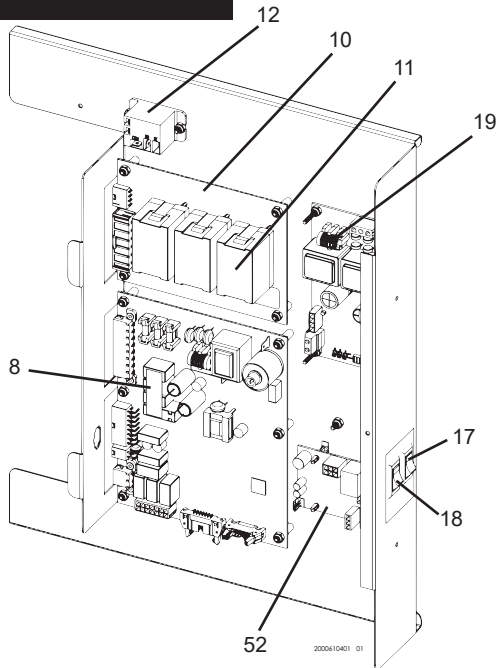

HEAT EXCHANGER (FTX400-850)

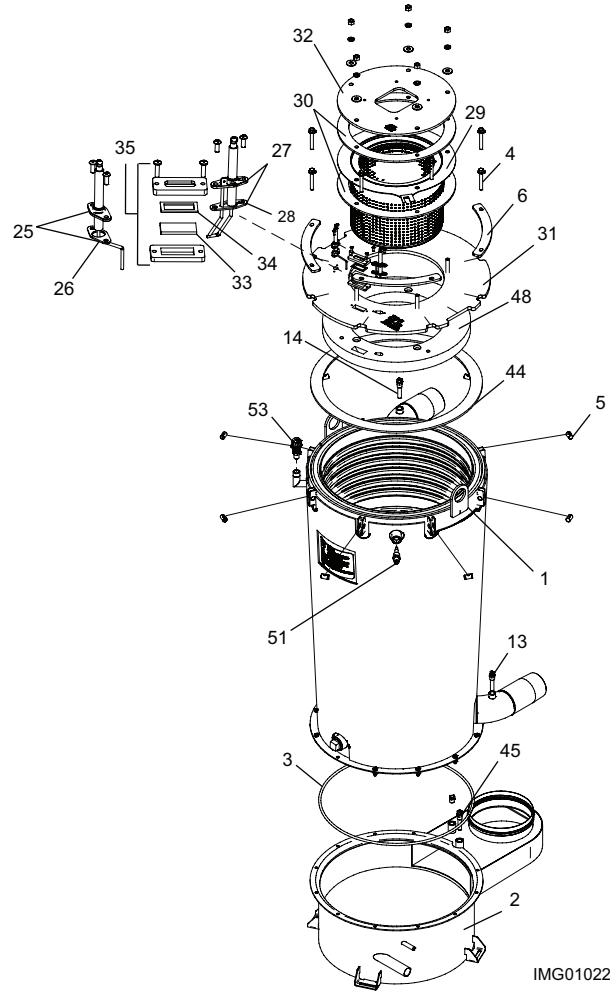

HEAT EXCHANGER (FTX1000)

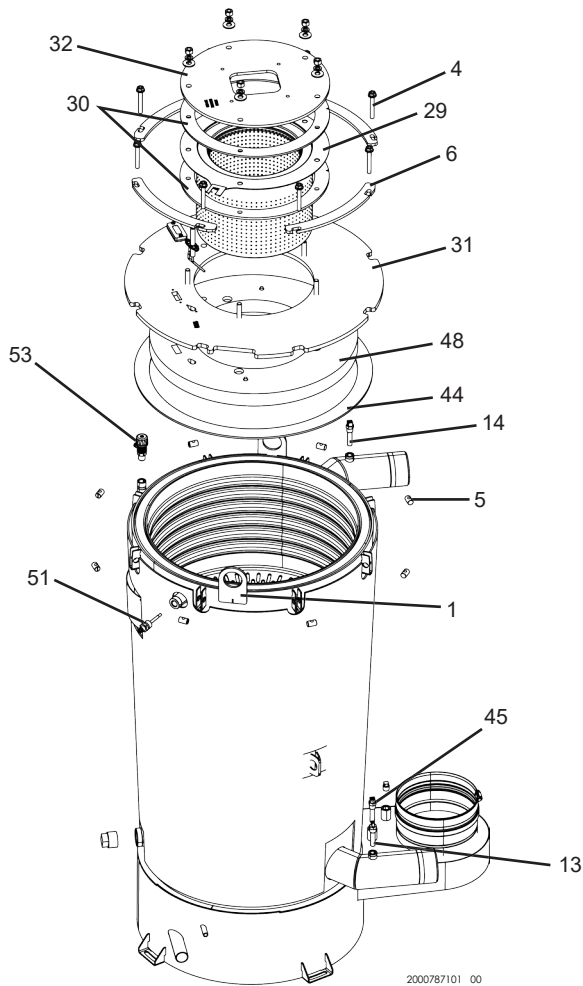

GAS TRAIN (FTX400 - 500 N/L)

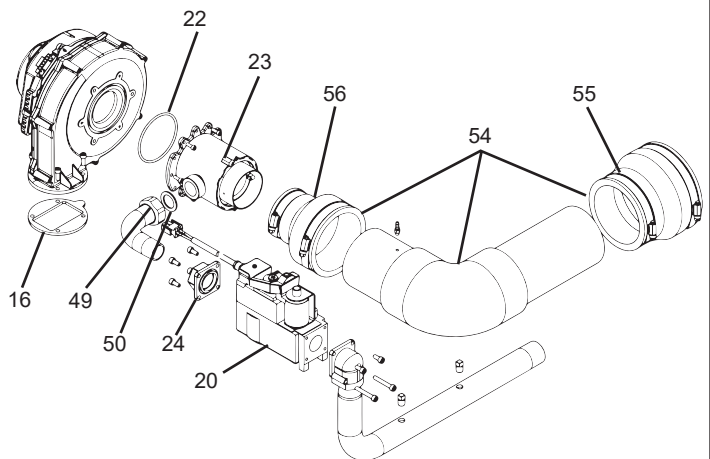

**GAS TRAIN
(FTX600 - 850 N/L)**

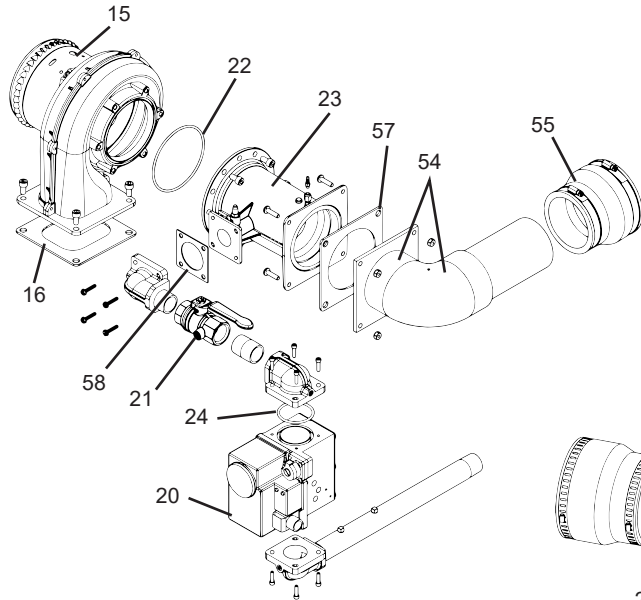

**GAS TRAIN
(FTX1000 N/L)**

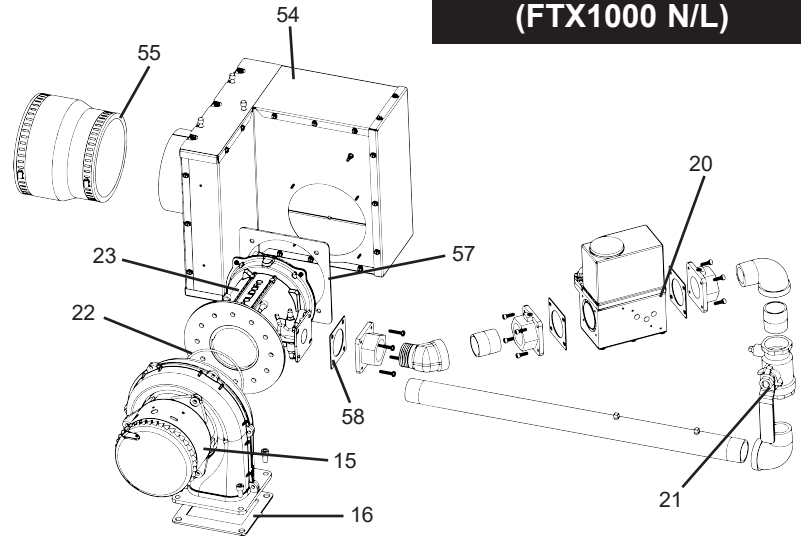

ITEM NO.	PART NO.	DESCRIPTION	MODEL
HEAT EXCHANGER ASSEMBLY			
1	100188998	HEAT EXCHANGER COMPLETE	FTX400
1	100188999	HEAT EXCHANGER COMPLETE	FTX500-600
1	100189000	HEAT EXCHANGER COMPLETE	FTX725
1	100189001	HEAT EXCHANGER COMPLETE	FTX850
1	100341241	HEAT EXCHANGER COMPLETE	FTX1000
2	100189002	HEAT EXCHANGER FLUE COLLECTOR	FTX400-600
2	100189003	HEAT EXCHANGER FLUE COLLECTOR	FTX725-850
3	100288873*	FLUE / HEAT EXCHANGER GASKET	FTX400-600
3	100288874*	FLUE / HEAT EXCHANGER GASKET	FTX725-850
-	100301815	FLUE GASKET, 4" MODELS	FTX400-600
-	100301832	FLUE GASKET, 6" MODELS	FTX725-1000
4	100288875	BOLT, HEX	ALL
5	100288876	NUT, HEX	ALL
6	100288904	WASHER, HEX	FTX 400-600
6	100288905	WASHER, HEX	FTX725-850
6	100341242	WASHER, HEX	FTX1000
CONTROLS			
7	100277838*	LOW VOLTAGE CONNECTION BOARD	ALL
8	100189280*	INTEGRATED CONTROL BOARD - SERIES 100/110	FTX400
8	100189281*	INTEGRATED CONTROL BOARD - SERIES 100/110	FTX500
8	100189282*	INTEGRATED CONTROL BOARD - SERIES 100/110	FTX600
8	100189283*	INTEGRATED CONTROL BOARD - SERIES 100/110	FTX725
8	100189284*	INTEGRATED CONTROL BOARD - SERIES 100/110	FTX850
8	100189285	INTEGRATED CONTROL BOARD - HIGH ALTITUDE - SERIES 100/110	FTX400
8	100189286	INTEGRATED CONTROL BOARD - HIGH ALTITUDE - SERIES 100/110	FTX500
8	100189287	INTEGRATED CONTROL BOARD - HIGH ALTITUDE - SERIES 100/110	FTX600

PLEASE HAVE MODEL AND SERIAL NUMBER WHEN ORDERING PARTS
*ITEMS DENOTE SUGGESTED INVENTORY PARTS

ITEM NO.	PART NO.	DESCRIPTION	MODEL
CONTROLS (CONTINUED)			
8	100189288	INTEGRATED CONTROL BOARD - HIGH ALTITUDE - SERIES 100/110	FTX725
8	100189289	INTEGRATED CONTROL BOARD - HIGH ALTITUDE - SERIES 100/110	FTX850
8	100367719	INTEGRATED CONTROL BOARD - SERIES 120	FTX400
8	100367743	INTEGRATED CONTROL BOARD - SERIES 120	FTX500
8	100367744	INTEGRATED CONTROL BOARD - SERIES 120	FTX600
8	100367745	INTEGRATED CONTROL BOARD - SERIES 120	FTX725
8	100367746	INTEGRATED CONTROL BOARD - SERIES 120	FTX850
8	100346582	INTEGRATED CONTROL BOARD	FTX1000
8	100367747	INTEGRATED CONTROL BOARD - HIGH ALTITUDE - SERIES 120	FTX400
8	100367748	INTEGRATED CONTROL BOARD - HIGH ALTITUDE - SERIES 120	FTX500
8	100367749	INTEGRATED CONTROL BOARD - HIGH ALTITUDE - SERIES 120	FTX600
8	100367750	INTEGRATED CONTROL BOARD - HIGH ALTITUDE - SERIES 120	FTX725
8	100367811	INTEGRATED CONTROL BOARD - HIGH ALTITUDE - SERIES 120	FTX850
8	100346588	INTEGRATED CONTROL BOARD - HIGH ALTITUDE	FTX1000
9	100278134*	USER INTERFACE CONTROL - SERIES 100/110	FTX400-850
10	100208493*	PUMP RELAY BOARD, 1.5 HP	ALL
11	100208502*	RELAY, 1.5 HP PUMP	ALL
12	100208509*	RELAY, 120VAC, 60HZ, 10.8 AMP	ALL
13	100208549*	INLET SENSOR	ALL
14	100208544*	OUTLET SENSOR/ HIGH LIMIT	ALL
15	100188879	FAN ASSEMBLY	FTX400
15	100188878	FAN ASSEMBLY	FTX500
15	100188877	FAN ASSEMBLY	FTX600-850
15	100341245	FAN ASSEMBLY	FTX1000
16	100288877	GASKET, FAN	FTX400-500
16	100288878	GASKET, FAN	FTX600-1000
17	100277798	MOMENTARY SWITCH, BLACK - 20 AMP, 125 VOLT	ALL
18	100277797	MOMENTARY SWITCH, RED - 20 AMP, 125 VOLT	ALL
19	100277771	MODBUS INTERFACE BOARD-MTR-01	ALL
GAS VALVES			
20	100189393	GAS VALVE ASSEMBLY NAT & LP	FTX400
20	100189392	GAS VALVE ASSEMBLY NAT & LP	FTX500
20	100189391	GAS VALVE ASSEMBLY NAT	FTX600
20	100189390	GAS VALVE ASSEMBLY NAT	FTX725
20	100189389	GAS VALVE ASSEMBLY NAT	FTX850
20	100341246	GAS VALVE ASSEMBLY NAT	FTX1000
20	100189388	GAS VALVE ASSEMBLY LP	FTX600
20	100189387	GAS VALVE ASSEMBLY LP	FTX725
20	100189386	GAS VALVE ASSEMBLY LP	FTX850
20	100341248	GAS VALVE ASSEMBLY LP	FTX1000
21	100277803	GAS CUT OFF VALVE 3/4"	FTX500
21	100288546	GAS CUT OFF VALVE 1"	FTX600-850
21	100294593	GAS CUT OFF VALVE 1.25"	FTX1000
22	100208761*	GASKET, FAN / VENTURI	FTX400-500
22	100233705*	GASKET, FAN / VENTURI	FTX600-1000
23	100278070	VENTURI ASSEMBLY - NATURAL	FTX400-500
23	100288545	VENTURI ASSEMBLY - LP	FTX400-500
23	100288547	VENTURI ASSEMBLY	FTX600
23	100288879	VENTURI ASSEMBLY	FTX725-850
23	100359326	VENTURI ASSEMBLY - NATURAL - SERIES 110	FTX1000
23	100359328	VENTURI ASSEMBLY - LP - SERIES 110	FTX1000
24	100375766	GAS VALVE FLANGE W/ GASKET	FTX400
24	100288880	GASKET, GAS VALVE	FTX500
24	100288891	GASKET, GAS VALVE	FTX600-850
PILOT & BURNER ASSEMBLIES			
25	100165923*	FLAME SENSOR W/ GASKET	ALL
26	100233664	GASKET, FLAME SENSOR	ALL
27	100165924*	IGNITOR W/ GASKET	ALL
28	100233662	GASKET, IGNITOR	ALL

PLEASE HAVE MODEL AND SERIAL NUMBER WHEN ORDERING PARTS
*ITEMS DENOTE SUGGESTED INVENTORY PARTS

ITEM NO.	PART NO.	DESCRIPTION	MODEL
PILOT & BURNERS ASSEMBLIES (CONTINUED)			
29	100188648	BURNER W/ GASKET	FTX400
29	100188649	BURNER W/ GASKET	FTX500-600
29	100188650	BURNER W/ GASKET	FTX725-850
29	100341244	BURNER W/ GASKET	FTX1000
30	100288892*	GASKET, BURNER	FTX400-600
30	100288893*	GASKET, BURNER	FTX725-1000
31	100189410	HEAT EXCHANGER DOOR ASSEMBLY	FTX400-600
31	100189409	HEAT EXCHANGER DOOR ASSEMBLY	FTX725-850
31	100341258	HEAT EXCHANGER DOOR ASSEMBLY	FTX1000
32	100189408	PLATE, FAN HEAT EXCHANGER ASSEMBLY	FTX400-500
32	100189407	PLATE, FAN HEAT EXCHANGER ASSEMBLY	FTX600
32	100189406	PLATE, FAN HEAT EXCHANGER ASSEMBLY	FTX725-850
32	100341259	PLATE, FAN HEAT EXCHANGER ASSEMBLY	FTX1000
MISCELLANEOUS			
33	100274750	SIGHT GLASS	ALL
34	100274752	GASKET, SIGHT GLASS - WHITE	ALL
35	100189215	KIT, SIGHT GLASS W/ GASKETS	ALL
36	100189217	DISPLAY BEZEL ASSEMBLY - SERIES 100/110	FTX400 - 850
36	100381515	DISPLAY BEZEL ASSEMBLY - SERIES 110/120	FTX400 - 1000
37	100278236	DISPLAY BEZEL - SERIES 100/110	FTX400 - 850
38	100288909	BEZEL PROP ROD	ALL
39	100288910	HINGE SPRING	ALL
40	100277718	CONDENSATE TRAP (PRIOR TO SERIAL #1741)	FTX400 - 850
40	100284709	CONDENSATE TRAP (BEGINNING SERIAL #1741)	ALL
41	100288163	HOSE, CONDENSATE	ALL
42	100208246	TRANSFORMER, 24V, 60VA	ALL
43	100277824	FLUTED KNOB W/ SKIRT - SERIES 100/110	FTX400 - 850
44	100288908*	HEAT EXCHANGER GASKET SET	FTX400 - 600
44	100288921*	HEAT EXCHANGER GASKET SET	FTX725 - 850
44	100341260*	HEAT EXCHANGER GASKET SET	FTX1000
45	100208561*	SENSOR, FLUE TEMP	ALL
46	100288894	TOP INSULATION	FTX400-500
46	100288895	TOP INSULATION	FTX600
46	100288896	TOP INSULATION	FTX725-850
46	100341262	TOP INSULATION	FTX1000
47	100288897	BLANKET INSULATION	FTX400-600
47	100288898	BLANKET INSULATION	FTX725-850
47	100341263	BLANKET INSULATION	FTX1000
48	100288927	BURNER FIBERBOARD	FTX400-600
48	100288928	BURNER FIBERBOARD	FTX725-850
48	100341264	BURNER FIBERBOARD	FTX1000
49	100278091	UNION ADAPTER	FTX400-500
50	100288899	1" DONUT GASKET	FTX400-500
51	100309672	PROBE, LOW WATER CUT-OFF	ALL
52	100276822*	LOW WATER CUT-OFF - AUTO / MANUAL RESET	ALL
53	100167445	AIR VENT VALVE	ALL
54	100189214	AIR INLET KIT	FTX400-500
54	100189213	AIR INLET KIT	FTX600-850
54	100341266	AIR INLET KIT	FTX1000
55	100288558	COUPLING, AIR INLET, 3" X 4"	FTX400-850
55	100375765	COUPLING, AIR INLET, 5" X 6"	FTX1000
56	100275561	AIR INLET COUPLING, 2" X 3", W/ CLAMPS	FTX400-500
57	100208089	GASKET, VENTURI INLET	FTX600-850
57	100341267	GASKET, VENTURI INLET	FTX1000
58	100208105	GASKET, GAS VALVE / VENTURI	FTX600-1000
-	100208242	ON / OFF SWITCH W/ I-O SYMBOL	ALL
-	100208454	RELIEF VALVE, 3/4", 50 PSI	FTX400-600
-	100208442	PRESSURE RELIEF VALVE, 3/4", 50 PSI	FTX725-1000
-	100208834	OUTDOOR AIR SENSOR	ALL

PLEASE HAVE MODEL AND SERIAL NUMBER WHEN ORDERING PARTS
*ITEMS DENOTE SUGGESTED INVENTORY PARTS

ITEM NO.	PART NO.	DESCRIPTION	MODEL
MISCELLANEOUS (CONTINUED)			
-	100208152	GAUGE TRIOMETER, 75 PSI	ALL
-	100208552	SENSOR, SYSTEM / INLET	ALL
-	100208308	DOOR CATCH, BLUE - SERIES 100/110	FTX400-850
-	100208818	DOOR STRIKE - SERIES 100/110	FTX400-850
-	100277748	WIRE HARNESS, UNIT - SERIES 100/110	FTX400-850
-	100367814	WIRE HARNESS, UNIT - SERIES 120	FTX400-850
-	100346594	WIRE HARNESS, UNIT	FTX1000
-	100288900	WIRE HARNESS, POWER	FTX400-850
-	100346592	WIRE HARNESS, POWER	FTX1000
-	100278061	WIRE HARNESS, FLAME SENSOR ELECTRODE	ALL
-	100208620	WIRE HARNESS, SPARK ELECTRODE	ALL
-	100288901	RIBBON CABLE - SERIES 100/110	FTX400-850
-	100346596	COMMUNICATION HARNESS - SERIES 120	FTX400-850
		COMMUNICATION HARNESS	FTX1000
-	100288902	WIRE HARNESS, GAS VALVE	FTX400-500
-	100299111	WIRE HARNESS, GAS VALVE	FTX600-1000
-	100170645	SYSTEM SENSOR KIT W/ BULB WELL	ALL
-	100189160	INSTALLATION KIT	FTX400-600
-	100189161	INSTALLATION KIT	FTX725-850
-	100341351	INSTALLATION KIT	FTX1000
-	100189174	LP CONVERSION KIT	FTX400-500
-	100189175	LP CONVERSION KIT	FTX600-850
-	100341272	LP CONVERSION KIT	FTX1000
-	100289529	USER INTERFACE OVERLAY LABEL - SERIES 100/110	FTX400-850
JACKET ASSEMBLY			
59	100189062	JACKET, OUTER FRONT - SERIES 100/110	FTX400-850
59	100367815	JACKET, OUTER FRONT - SERIES 120	FTX400-850
59	100341269	JACKET, OUTER FRONT - SERIES 110	FTX1000
60	100189063	JACKET, OUTER RIGHT - SERIES 100/110	FTX400-850
60	100367816	JACKET, OUTER RIGHT - SERIES 120	FTX400-850
60	100341270	JACKET, OUTER RIGHT - SERIES 110	FTX1000
61	100189064	JACKET, OUTER LEFT - SERIES 100/110	FTX400-850
61	100367818	JACKET, OUTER LEFT - SERIES 120	FTX400-850
61	100341271	JACKET, OUTER LEFT - SERIES 110	FTX1000
62	100381516	JACKET, OUTER TOP - SERIES 120	FTX400-850
62	100381517	JACKET, OUTER TOP - SERIES 110	FTX1000
ANNUAL PREVENTATIVE MAINTENANCE KITS			
-	100320868	KIT, PM SERVICE	FTX400-500
-	100320870	KIT, PM SERVICE	FTX600
-	100320881	KIT, PM SERVICE	FTX725-850
-	100363401	KIT, PM SERVICE	FTX1000

PLEASE HAVE MODEL AND SERIAL NUMBER WHEN ORDERING PARTS
*ITEMS DENOTE SUGGESTED INVENTORY PARTS

