

Service Handbook



Lochinvar[®]
HIGH EFFICIENCY BOILERS & WATER HEATERS

Residential Hybrid Electric Heat Pump Water Heaters

FOR USE ONLY WITH THESE MODELS:

HPA052KD, HPA068KD, HPA082KD

PREVENTIVE MAINTENANCE

OPERATION & SERVICE

TROUBLESHOOTING

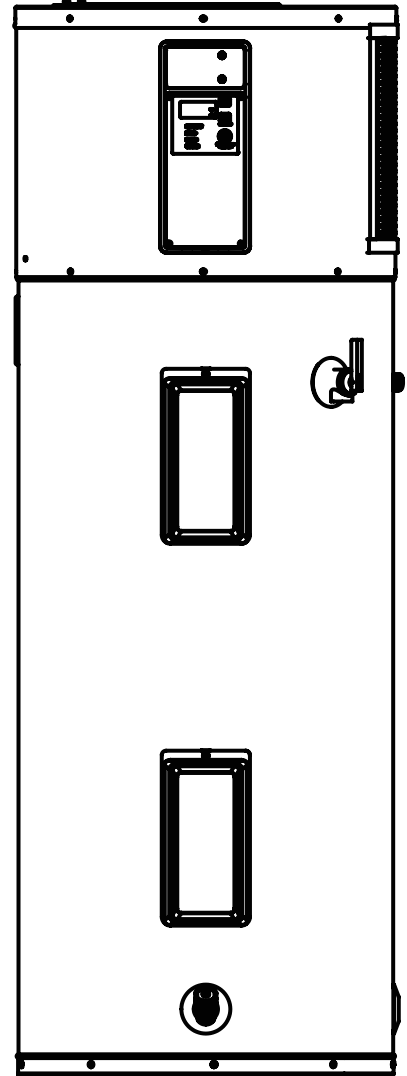

THIS SERVICE HANDBOOK IS FOR USE BY QUALIFIED SERVICE PROFESSIONALS ONLY.

100314819_ Rev. A
January 2019

TABLE OF CONTENTS

Basics.....	3
Completed Installation.....	3
Safety.....	5
Required Tools.....	7
Operation	8
Water Temperature Adjustment	8
Operating Mode Descriptions	8
Accessing Maintenance Display	10
Troubleshooting	11
Before Using	11
Drips from T&P Relief Valve Discharge Pipe.....	11
Post Installation Review	12
Closed System/Thermal Expansion/T&P Drip	12
Checking the Air Charge of the Thermal Expansion Tank.....	13
Power Cycling the Unit.....	13
Diagnostic Codes.....	14-15
Troubleshooting Chart	16-17
Maintenance	18
Testing the Element	18
Replacing the Element	18
Replacing the ECO.....	19-20
T&P Relief Valve Maintenance	20
Air Filter Maintenance	21
Changing the Anode.....	21
System Checks	22
Compressor Check Flowchart.....	22-23
Fan Check Flowchart	24
Appendix	25
Control Board Overview.....	25-26
Wiring Diagrams.....	27-29
Repair Parts Lists	30

COMPLETED INSTALLATION (TYPICAL)

TYPICAL INSTALLATION FOR 240V OR 208V/240V

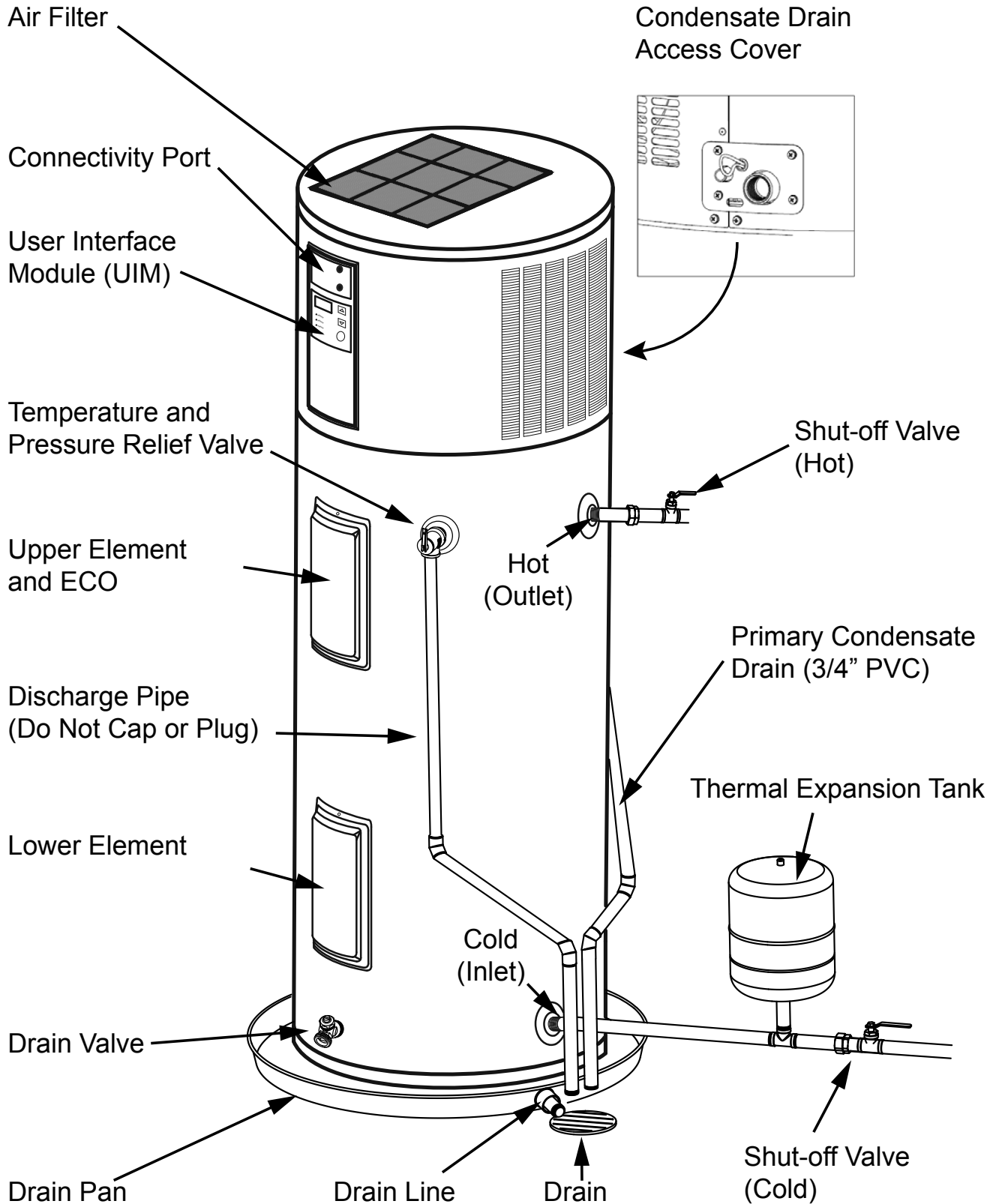

IMPORTANT SAFETY INFORMATION

Read and follow all safety messages and instructions in this manual.

	<p>This is the safety alert symbol. It is used to alert you to potential physical injury hazards. Obey all safety messages that follow this symbol to avoid possible property damage, serious injury or death. Do not remove any permanent instructions, labels, or the data plate from either the outside of the water heater or on the inside of the access panels. Keep this manual near the water heater.</p>
---	---

	DANGER indicates hazardous situation that, if not avoided, will result in death or serious injury.
	WARNING indicates a hazardous situation that, if not avoided, could result in death or serious injury.
	CAUTION indicates a hazardous situation that, if not avoided, could result in minor or moderate injury.
	NOTICE indicates practices not related to physical injury.

Important information to keep

Fill out this section and keep this manual in the pocket of the water heater for reference.

Date Purchased:

Model number:

Serial number:

Maintenance performed:*	Date:

*Drain and flush tank, clean air filter, clean condensate pan, and remove and inspect anode rod after first six months of operation and at least annually thereafter. Operate the Temperature and Pressure Relief Valve (T&P) annually and inspect T&P valve every 2-4 years (see the label on the T&P valve for maintenance schedule). See the Maintenance section for more information about maintaining this water heater.

IMPORTANT SAFETY INFORMATION

To reduce the risk of property damage, serious injury or death, read and follow the precautions below, all labels on the water heater, and the safety messages and instructions throughout this manual.

RISKS DURING INSTALLATION AND MAINTENANCE



Electric Shock Risk

Contact with the electrical parts in the junction box, behind the access doors and inside the top shroud can result in severe injury or death from electrical shock:

- Disconnect power by opening the circuit breaker or removing the disconnects before installing or servicing.
- Use a non-contact circuit tester to confirm that power is off before working on or near any electrical parts.
- Replace the junction box cover and access doors after servicing.



Lifting Risk

The water heater is heavy. Follow these precautions to reduce the risk of property damage, injuries from lifting or impact injuries from dropping the water heater.

- Use at least two people to lift the water heater.
- Be sure you both have a good grip before lifting.
- Unit is top heavy, use an appliance dolly (with strap) to move the water heater.

RISKS DURING OPERATION

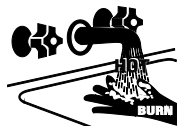

Scalding Risk

This water heater can make water hot enough to cause severe burns instantly, resulting in severe injury or death.

- Feel water before bathing or showering
- To reduce the risk of scalding, install Thermostatic Mixing Valves (temperature limiting valves) at each point-of-use. These valves automatically mix hot and cold water to limit the temperature at the tap. Mixing valves are available from your local plumbing supplier. Follow manufacturer’s instructions for installation and adjustment of the valves.
- The User Interface Module (UIM) on this water heater have been factory set to approximately 120°F to reduce the risk of scalding. Higher temperatures increase the risk of scalding, but even at 120°F, hot water can scald. If you choose a higher temperature, Thermostatic Mixing Valves located at each point-of-use are particularly important to help avoid scalding.

Temperature	Time to Produce a Serious Burn
120°F (49°C)	More than 5 minutes
125°F (52°C)	1½ to 2 minutes
130°F (54°C)	About 30 seconds
135°F (57°C)	About 10 seconds
140°F (60°C)	Less than 5 seconds
145°F (63°C)	Less than 3 seconds
150°F (66°C)	About 1½ seconds
155°F (68°C)	About 1 second

For information about changing the factory thermostat setting(s), refer to the “Water Temperature Adjustment” section in this manual (on page 9).

Even if you set the water heater thermostat(s) to a low setting, higher temperatures may occur in certain circumstances:

- In some cases, repeated small draws of water can cause the hot and cold water in the tank to “stack” in layers. If this happens, the water can be as much as thirty degrees hotter than the thermostat setting. This temperature variation is the result of your usage pattern and is not a malfunction.
- Water temperature will be hotter if someone adjusted the UIM to a higher setting.
- Problems with the UIM, or other malfunctions may result in higher than expected water temperatures.
- If the water heater is in a hot environment, the water in the tank can become as hot as the surrounding air, regardless of the thermostat setting.
- If the water supplied to the water heater is pre-heated (for example, by a solar system) the temperature in the tank may be higher than the water heater’s thermostat setting.

To reduce the risk of unusually hot water reaching the fixtures in the house, install Thermostatic Mixing Valves at each point-of-use.

If anyone in your home is at particular risk of scalding (for example, the elderly, children, or people with disabilities) or if there is a local code or state law requiring a certain water temperature at the hot water tap, then these precautions are particularly important.

IMPORTANT SAFETY INFORMATION

According to a national standard American Society of Sanitary Engineering (ASSE 1070) and most local plumbing codes, the water heater's thermostat should not be used as the sole means to regulate water temperature and avoid scalds.

Properly adjusted Thermostatic Mixing Valves installed at each point-of-use allow you to set the tank temperature to a higher setting without increasing risk of scalds. A higher temperature setting allows the tank to provide much more hot water and can help provide proper water temperatures for appliances such as dishwashers and washing machines. Higher tank temperatures (140°F) also kill bacteria that cause a condition known as "smelly water" and can reduce the levels of bacteria that cause water-borne diseases.

Water Contamination Risk

Do not use chemicals that could contaminate the potable water supply. Do not use piping that has been treated with chromates, boiler seal, or other chemicals.



Fire Risk

To reduce the risk of a fire that could destroy your home and seriously injure or kill people:

- Do not store things that can burn easily such as paper or clothes next to the water heater.
- Be sure the junction box cover and the access door covers are in place. These covers keep debris from entering and potentially being ignited, and help keep any internal fires from spreading.

- Keep the water heater from becoming wet. Immediately shut the water heater off and have it inspected by a qualified person if you find that the wiring, thermostat(s) or surrounding insulation have been exposed to water in any way (e.g., leaks from plumbing, leaks from the water heater itself can damage property and could cause a fire risk). If the water heater is subjected to flood conditions or the thermostat(s) have been submerged in water, the entire water heater must be replaced.



Explosion Risk

High temperatures and pressures in the water heater tank can cause an explosion resulting in property damage, serious injury or death. A new Temperature and Pressure (T&P) Relief Valve is included with your water heater to reduce risk of explosion by discharging hot water. Additional temperature and pressure protective equipment may be required by local codes.

A nationally recognized testing laboratory maintains periodic inspection of the valve production process and certifies that it meets the requirements for Relief Valves for Hot Water Supply Systems, ANSI Z21.22. The T&P Relief Valve's relief pressure must not exceed the working pressure rating of the water heater as stated on the rating plate.

Maintain the T&P Relief Valve properly. Follow the maintenance instructions provided by the manufacturer of the T&P Relief Valve (label attached to T&P Relief Valve) and the procedures provided in the Use and Care Guide.

An explosion could occur if the T&P Relief Valve or discharge pipe is blocked. Do not cap or plug the T&P Relief Valve or discharge pipe.

Fire and Explosion Risk if Hot Water is Not Used for Two Weeks or More

▲ CAUTION! Hydrogen gas builds up in a hot water system when it is not used for a long period (two weeks or more). Hydrogen gas is extremely flammable. If the hot water system has not been used for two weeks or more, open a hot water faucet for several minutes at the kitchen sink before using any electrical appliances connected to the hot water system. Do not smoke or have an open flame or other ignition source near the faucet while it is open.

GENERAL SAFETY

Your safety and the safety of others is extremely important in the servicing of this water heater. Many safety-related messages and instructions have been provided in this handbook and on your water heater to warn you of a potential hazard(s). Read, understand and follow all instructions in this handbook and in the Installation Instructions and Use & Care Guide that shipped with the water heater.

The information contained in this handbook is designed to answer common situations encountered when operating or servicing the residential electric heat pump water heater, it is not meant to be all-inclusive. For topics not covered in this handbook, please contact the technical information center listed on the back cover of this handbook for further assistance. Additional information is also available on the website listed on the back cover of this handbook.

This handbook is intended for use by qualified service technicians.

The water heater must be returned to a safe condition anytime the water heater is left unattended during or after servicing. All original components must be re-installed and all safety measures must be implemented. Additionally, the water temperature setting should be returned to manufacturer's set point of 120°F.

Tools required for servicing residential electric heat pump water heater models:



- Digital multimeter (with alligator leads and continuity tester)
- Clamp style amp meter
- Megohm meter
- Water pressure gauge
- Thermometer (2)
- T20 torx bit (for junction box access)
- 18" extension, for anode removal (1/2" drive minimum)
- 6" extension, for element removal (1/2" drive minimum)
- 1-1/16" - 6 point deep well socket for anode removal (1/2" drive minimum)
- 1-1/2" - socket for element removal (1/2" drive minimum)
- Ratchet and breaker bar
- Nut drivers: 5/16" & 9/32" (hollow shaft)
- Non-contact voltage tester
- Common hand tools (screwdrivers, pliers, etc.)
- Tape and a permanent marker to mark the wires
- Megohm meter

OPERATION

Water Temperature Adjustment

The water temperature can be adjusted from 95°F / 35°C to 140°F / 60°C (240V model) and 95°F/35°C to 150°F/66°C (208V/240V models).

Use the Up and Down Buttons

  on the front panel to set the desired temperature (see figure 2 on page 11). The setting temperature will blink on the display, press Mode/Enter button to confirm.

The water temperature can be adjusted quickly by pressing the “Temperature Up” button and holding for three seconds.

NOTE: Before attempting to adjust the thermostat, read the “Risks During Operation” section on page 6. If the instructions are not clear, contact Residential Technical Support.

NOTE: For increased water demand, switching (temporarily) to Hybrid Mode or Electric Mode will decrease the recovery/re-heat time. Be sure to switch back to the desired operational mode when finished.

Operating Mode Descriptions

The operating modes can be changed either sequentially by pressing the Mode/Enter button (Figure 1, page 10); or, alternately, newer models can be changed by pressing and holding the UP button to enter vacation mode (Figure 2, page 10). The Operation Mode Indication Light will turn on when the relevant mode is selected.

Efficiency Mode -

Provides the highest efficiency and lowest cost operation by using only the heat pump for heating. Recovery time and efficiency will vary with ambient temperature and relative humidity. Efficiency will be greatest, and recovery quickest, when both are high. At lower temperatures and relative humidity levels, efficiency will be lower and recovery will take longer. Heat pump operation is allowed between 45°F / 7.2°C to 120°F / 48.8°C ambient temperature. At ambient temperatures lower than 45°F / 7.2°C and greater than 120°F / 48.8°C, the heat pump will not operate. Similarly, if the water temperature in the tank is less than 59°F / 15°C, the heat pump will not operate. The unit will operate in electric mode until ambient and water temperatures return to the safe operating range of the heat pump.

Hybrid Mode -

This is the default, recommended setting, combining high energy efficiency with reduced recovery time. This mode uses the heat pump as the primary heating source. In this mode, the heat pump section operates the same as if it were in efficiency mode. The heating element will also heat water in conjunction with the heat pump during periods of higher hot water demand so that the set point temperature can be attained more quickly.

Electric Mode -

The water heater functions as a conventional electric unit by relying on only the elements to heat the water. The heat pump section will not operate in this mode. This mode may be useful in periods of increased hot water demand. After 48 hours, the water heater will revert to the default mode setting.

Vacation Mode -

The controller will not allow the temperature to drop below 60°F while in Vacation setting. This mode is recommended when the water heater is not in use for a long period of time, to minimize energy consumption and prevent the water heater from freezing during cold conditions.

▲ CAUTION! Hydrogen gas builds up in a hot water system when it is not used for a long period (two weeks or more). Hydrogen gas is extremely flammable. If the hot water system has not been used for two weeks or more, open a hot water faucet for several minutes at the kitchen sink before using any electrical appliances connected to the hot water system. Do not smoke or have an open flame or other ignition source near the faucet while it is open.

OPERATION

NOTE: When Vacation Mode is selected, the vacation timer will be displayed. Press the Up and Down button to modify the timer to desired number of vacation days (setting range: 1 to 99 days). The vacation timer will blink on the display; press the Mode/Enter button to confirm the vacation timer. To deactivate Vacation Mode, press the Mode/Enter button to switch to the desired mode.

Other Controls

°F/°C Switch - Press “Temperature Down” button and hold for 3 seconds to switch temperature unit between Fahrenheit and Celsius

Power Saver Enable/Disable:

- Press “Mode/Enter” button and hold for 3 seconds. The power saver, or remote access feature will be activated and the display will show either “P.S.” (not to be mistaken with P5) or “R.A.”, and the setting temperature alternatively. This feature allows the unit to be managed by grid or other utility based load management programs.
- To deactivate the power saver or remote access, press “Mode/Enter” button and hold for 3 seconds.

Heat pump defrosting indication:

- There will be frost accumulating on the evaporator when the heat pump is operated in low ambient temperatures. The controller will order the unit to enter into defrosting cycle to optimize the heat pump operation performance. During the defrosting period, the user interface module will display “ICE” as an indication.

Out of heat pump operation range:

- The user interface module will display “HPO” as an indication that the ambient and/or water temperature condition is out of the heat pump operation range.

NOTE: The display will go into “Sleep Mode” for energy saving if there is no operation on any button for 15 minutes. All the display and lights will be turned off. During this time the heater will operate in the electric mode to heat water until ambient or water temperature conditions are again inside the operating envelope, (The “Operating Mode” indicator light may remain illuminated for some models while in sleep mode). The display can be awakened by pressing any button.

NAVIGATING (OR USING) THE UIM

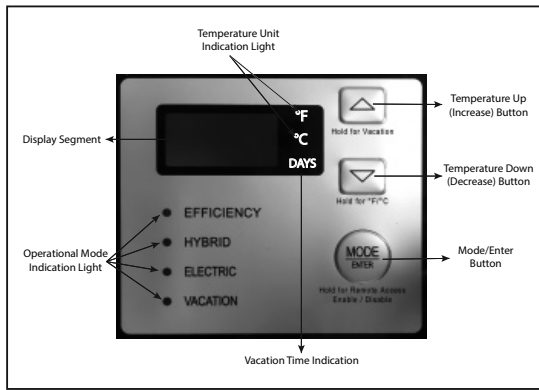

Figure 1 - UIM Display (208V/240V)

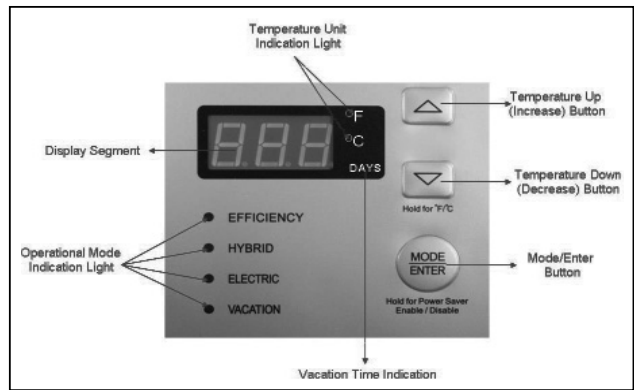

Figure 2 - UIM Display (240V & early release 208V/240V)

Accessing the Maintenance Display:

1. Press the Up and Down buttons at the same time and hold for (3) seconds. The display will enter the Maintenance Display Mode. The display will alternate between the display designation (EX:P1) and the associated information.
2. A total of 13 options are available in this mode (see Table below). Use the Up and Down Temperature buttons to switch between each option.
3. The display will revert to normal operation after no buttons have been pressed over a period of approximately (5) seconds.

NOTE: When powered on, the unit will perform a system self-diagnostic. This typically takes (8) eight minutes (The user interface module will display scrolling dashes repetitively during self-diagnostic). When the self-diagnostic is complete the display will begin normal operation. If the system diagnostic discovers any issues, a diagnostic code will be displayed. A complete list of diagnostic codes can be found in the Diagnostic Codes section of this manual.

Table 1: Maintenance Display			
Display		Message	Meaning
1	P1	Upper Tank Temperature	Measured at outer upper tank wall
2	P2	Lower Tank Temperature	Measured at outer lower tank wall
3	P3	Coil Temperature	Measured at hairpin of evaporator
4	P4	Discharge Temperature	Measured at compressor discharge pipe
5	P5	Suction Temperature	Measured at evaporator outlet pipe
6	P6	EEV Pulses	EEV (Electronic Expansion Valve) opening indication
7	P7	Upper Element Status	0: Upper element is off 1: Upper element is on
8	P8	Lower Element Status	0: Lower element is off 1: Lower element is on
9	P9	Software Version	"vXY" means the software version is "X.Y"
10	H1	History Fault 1 Code	Newest active fault code
11	H2	History Fault 2 Code	Historical fault
12	H3	History Fault 3 Code	Historical fault
13	H4	History Fault 4 Code	Historical fault

NEW INSTALLATIONS

⚠ WARNING! Do not cap or plug the T&P relief valve or discharge pipe, and do not operate the water heater without a functioning T&P relief valve - this could cause an explosion.

Before Using:

- 1** Make sure the water heater has been properly installed, according to the Installation and Use and Care Guide.
- 2** Make sure the air filter is correctly seated, as it may shift during shipping or installation.
NOTE: The top of the unit must be kept clear to provide air into the water heater. Verify nothing is blocking the inlet or exhaust air flow (See “Repair Parts Illustration” page 26).
- 3** Make certain the tank is completely filled with water, (see Use & Care Guide).
- 4** After the water heater is completely filled with water, connect electrical power to the water heater.

NOTE: When powered on, the unit will perform a system self-diagnostic. This typically takes (8) eight minutes (The user interface module will display scrolling dashes repetitively during self-diagnostic). When the self-diagnostic is complete the display will begin normal operation. If the system diagnostic discovers any issues, a diagnostic code will be displayed. A complete list of diagnostic codes can be found in the Diagnostic Codes section of this manual.

- 5** Adjust the set point temperature. See the “Water Temperature Adjustment” section on page 8.

IMPORTANT: Do not attempt to operate this water heater if the unit has been submerged, subjected to flooding, or surrounding insulation has been exposed to water in any way.

Do not attempt to repair a unit that has been subjected to flood conditions. Water heaters that have been subjected to flood conditions or any time the unit has been submerged in water must be replaced.

Drips from Temperature and Pressure (T&P) Relief Valve Discharge Pipe:

A small amount of water dripping from the Temperature and Pressure (T&P) Relief Valve usually means the home’s water pressure is too high or you need a properly sized and pressurized Thermal Expansion Tank. Refer to the installation instructions in the Use and Care Guide and “Checking the Air Charge of the Thermal Expansion Tank” section of this manual, page 13. A large amount of hot water coming from the T&P discharge pipe may be due to the tank overheating.

Water pressure too high: Water pressure can cause the T&P Relief Valve to drip. Install a Pressure Reducing Valve (PRV) on the main cold water supply line. Adjust the PRV to between 50 and 60 psi.

Thermal Expansion Tank: Install a Thermal Expansion Tank. If a Thermal Expansion Tank is already installed and the T&P Relief Valve discharge pipe drips, the Thermal Expansion Tank may be pressurized to the wrong pressure or the internal bladder may be defective. Refer to the instructions that came with the Thermal Expansion Tank for more information, see “Checking the Air Charge of the Thermal Expansion Tank” section, page 13.

Debris: In rare cases debris can stick inside the T&P Relief Valve preventing the valve from seating fully. In that case, the T&P Relief Valve discharge pipe will drip. You may be able to clear debris from the T&P Relief Valve by manually operating the valve, allowing small quantities of water to flush out the debris. See the label on the T&P Relief Valve for instructions.

If the water pressure is between 50 and 60 psi, a Thermal Expansion Tank is installed and properly pressurized, and the valve has been cleared of any debris, and it still drips, the valve may be broken. The T&P Relief Valve needs to be replaced.

NEW INSTALLATION TROUBLESHOOTING

Post Installation Review

- 1** Understand how to use the User Interface Module (UIM) to set the various modes and functions.
- 2** Hybrid Mode is the recommended Operating Mode. Review the various Operating Modes and which mode may be best, based on ambient temperature and hot water demands.
- 3** Understand the importance of routine inspection/maintenance of the condensate drain pan and lines. This is to prevent any possible drain line blockage resulting in the condensate drain pan overflowing.

NOTE: If water is coming from the overflow slot of the condensate drain access cover, this indicates that both condensate drain lines may be blocked and immediate action is required.

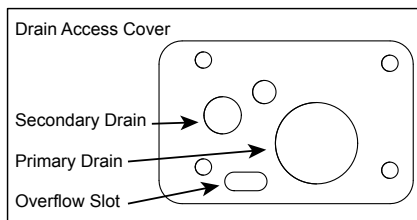

Figure 3 - Condensate Drain Access Cover

- 4** To maintain optimal operation, check, and clean the air filter as needed (see “Air Filter Maintenance” section on page 21).
- 5** The Installation Instructions and Use and Care Guide should be kept with the water heater for reference.

Closed System/Thermal Expansion/T&P Drip:

Most public water systems are required to prevent water flowing from points of use (residences, businesses, etc.) back into the municipal water supply. This creates what is known as a “Closed System”.

As water is heated, it expands. In a closed system the expansion of the water has nowhere to go, resulting in an increase in pressure. This increased pressure in the system can damage the water heater and may cause the T&P relief valve to open and relieve the pressure. Premature tank failure will result if this condition is not corrected. To prevent thermal expansion from increasing the system pressure, a properly sized thermal expansion tank should be installed on the cold water supply to the water heater (see example in the “Completed Installation” figure on page 3) The thermal expansion tank must be charged with air to match the incoming water pressure. Failure to install a properly sized thermal expansion tank in a closed system will void the warranty on the water heater in the event of tank failure. Always follow the manufacturer’s instructions that come with the expansion tank.

Contact a plumbing service agency or your retail supplier regarding the installation of a thermal expansion tank.

NEW INSTALLATION TROUBLESHOOTING

Checking and Adjusting the Air Charge of the Thermal Expansion Tank:

- 1 Turn off power to the water heater at the circuit breaker or remove disconnects.
- 2 Run cold water out of the tap for 10 seconds to relieve thermal expansion and then turn off the faucet.
- 3 Connect a water pressure gauge to the plumbing system and record the incoming water pressure.
- 4 Shut off the cold water supply.
- 5 Open a hot water tap and relieve the pressure from the plumbing system.
- 6 The preferred method for checking air pressure of a thermal expansion tank is to remove it from the plumbing if possible. Where it is not possible to remove the thermal expansion tank, take necessary precautions to insure water pressure at the plumbing connection to the expansion tank has been relieved. Failure to relieve water pressure at this location may invalidate the air pressure check. Improperly installed or charged thermal expansion tanks can result in premature leaking of the water heater.
NOTE: The air pressure check is not valid unless the thermal expansion tank is completely removed from the system.

7 Remove the cap from the air pressure Schrader valve and use the air pressure gauge to measure the air pressure charge of the expansion tank. The air pressure charge should match the recorded incoming water pressure.

NOTE: If water, rather than air, comes out of the Schrader valve the expansion tank will need to be replaced.

8 If the air charge does not match the incoming water pressure, adjust it by adding pressure with an air compressor or by relieving excess pressure at the Schrader valve until the air charge in the tank matches the pressure of the incoming water.

9 Re-install the thermal expansion tank.

10 Open all plumbing shut-off valves and turn on power to the water heater.

11 Check for leaks.

Power Cycling the Unit:

1 Find and turn off the water heater's circuit breaker or remove disconnects.

2 Find electrical junction box on side of water heater, remove cover and identify the two (2) power wires.

3 Turn circuit breaker back on (or re-install the disconnects) and check for power on both incoming power wires using a voltmeter.

4 Again, turn off water heater's circuit breaker, or remove disconnect and replace electrical junction box cover, before performing maintenance work.

NOTE: When powered on the unit will start to run a system diagnostic. This typically takes eight (8) minutes and the UIM will display - - - - repetitively during this period.

DIAGNOSTIC CODES

	DISPLAY SHOWS	INDICATES	CORRECTIVE ACTION
	(scrolling dashes)	Unit is running system diagnostic.	Normal operation--no action
	ICE	Heat pump is in defrost cycle.	
	HPO	Ambient temperature <45°F or >120°F, average tank temperature of 59°F or less.	
*	EUC	Upper element is not functioning	Refer to "Element Testing and Replacement" page 18.
	ELC	Lower element is not functioning	Refer to "Element Testing and Replacement" page 18
	SF	The air filter is dirty.	Refer to "Air Filter Maintenance" page 21
*	ECF	The heat pump compressor is starting/stopping frequently.	<ol style="list-style-type: none"> 1. If compressor is running and fan is not operating, refer to "Fan Check Flow Chart" page 24. 2. Clean the air filter. See "Air Filter Maintenance" section on page 21. 3. Check installation location against recommended confined space requirements, refer to Use & Care Guide.
*	E20 or E21	Upper Temperature Sensor is not functioning.	Power off (Power Cycling the unit, page 13), disconnect and reconnect J2 and J5 connections from control board Appendix pages 25-26 (for control board photos), inspect wire for damage, re-install UIM, reconnect power. If error persists, replace temperature sensor.
	E30 or E31	Lower Temperature Sensor is not functioning.	
	E50 or E51	Heat Pump Suction Temperature Sensor is not functioning.	
	E10 or E11	Heat Pump Coil Temperature Sensor is not functioning.	
	E40 or E41	Heat Pump Discharge Temperature Sensor is not functioning.	
*	E60	Upper and Lower Temperature Sensor are not functioning	
*	Edr	Not enough water in the tank (tank not full).	Open all hot water taps in home and run until water flows, uninterrupted (full stream for three minutes), from all open hot water taps.
	EPL	Power supply voltage is too low.	Check for loose electrical connections, refer to "Power Cycling the Unit", page 13.

NOTE: The diagnostic code listed above are the most common. If a diagnostic code not listed above is displayed, contact Technical Support referencing the number on the front of this manual.

* There may be an audible alarm associated with this error. To cancel the alarm, press any button on the UIM.

DIAGNOSTIC CODES

*	EDH	Compressor Discharge Temperature is too high.	Call Technical Support
*	EoF	Condensate management.	<ol style="list-style-type: none"> 1. Check to see if accessory condensate pump is plugged in and has power. Also check circuit breaker/fuse box and GFCI (if used). If error persists, proceed to the next step. 2. Check condensate pump outlet tube for blockage. If error persists, proceed to the next step. 3. Check for water in the condensation pan, ensure unit is installed level, check for blocked drain lines. 4. Check control wire connections to condensate pump. If error persists, proceed to the next step. (See Use & Care Guide for connecting the condensate pump) 5. Replace accessory condensate pump.
*	ECL	Heat pump suction pressure is too low.	Confirm physical connection of temperature sensor to the suction line.
	EEE	EEPROM failure	Power cycle unit. If error persists, replace control board.
*	ECC	Heat pump compressor is not functioning	See Compressor Check flowchart on pages 22 and 23.
	ECE	Power supply error.	Call Technical Support: 1-800-722-2101

NOTE: The diagnostic code listed above are the most common. If a diagnostic code not listed above is displayed, contact Technical Support referencing the number on the front of this manual.

* There may be an audible alarm associated with this error. To cancel the audible alarm, press any button on the UIM.

TROUBLESHOOTING CHART

PROBLEM	POSSIBLE CAUSE(S)	CORRECTIVE ACTION
NO DISPLAY	<ol style="list-style-type: none"> 1. Sleep Mode 2. No power to the water heater (No lights on the unit are on). 	<ol style="list-style-type: none"> 1. Touch any button to wake up UIM 2. Check for blown fuse or tripped breaker. Restore power to unit.
NO HOT WATER	<ol style="list-style-type: none"> 1. No power to the water heater (No lights on the unit are on). 2. Unit in Vacation mode 3. ECO tripped 4. Hot water usage pattern exceeds the capability of the water heater in current mode 5. Non-functioning upper temperature sensor 6. Faulty thermostatic mixing valve. 7. Leak in plumbing system 	<ol style="list-style-type: none"> 1. Check for blown fuse or tripped breaker. Restore power to unit. 2. Press Mode/Enter button and return to desired operating mode (page 9-10). 3. Reset the Energy Cut Off (ECO) switch; see "Check/Reset Energy Cut Off" section for more information (page 19). 4. Change to different mode or modify usage patterns (pages 8-9). 5. Refer to "Diagnostic Codes" section (pages 14-15). 6. Check hot water at other faucets. 7. Check hot water side of home's plumbing system for leaks.
INSUFFICIENT HOT WATER/ SLOW HOT WATER RECOVERY	<ol style="list-style-type: none"> 1. Temperature set-point too low 2. Air filter dirty 3. Hot water leak at faucet or piping 4. Non-functioning heating element 5. Hot water usage pattern exceeds the capability of the water heater in current mode 6. Water connections to unit reversed 7. Out of position outlet j-tube. 8. Thermostatic mixing valve faulty/set too low. 	<ol style="list-style-type: none"> 1. Increase set point temperature; see "Water Temperature Adjustment" section (page 8). 2. Clean air filter (page 21). 3. Repair hot water leaks. 4. Refer to "Diagnostic Codes" section (pages 14-15). 5. Change to different mode or modify usage patterns (For example if in Efficiency Mode switch to Hybrid Mode, pages 14-15). 6. Ensure the cold connection is at the bottom and that the hot connection is at the top. 7. Check orientation of alignment mark with arrow, re-install if necessary. 8. Check hot water at other faucets.
TEMPERATURE TOO HIGH	<ol style="list-style-type: none"> 1. Water temperature set point too high. 2. Grounded/shorted heating element. 3. Thermostatic mixing valve faulty/set too high. 	<ol style="list-style-type: none"> 1. Adjust UIM. 2. Replace heating element (see "Element Testing and Replacement", page 18). 3. Adjust temperature setting of thermostatic mixing valve.
LOW WATER PRESSURE	<ol style="list-style-type: none"> 1. Partially closed supply valve 	<ol style="list-style-type: none"> 1. Open supply valve completely.
WATER ODOR	<ol style="list-style-type: none"> 1. A sulfate reducing bacteria which has accumulated within the water heater (this harmless bacteria is nontoxic to humans). 	<ol style="list-style-type: none"> 1. Install thermostatic mixing valve, increase water temperature set point to 140°F
SOUNDS	<ol style="list-style-type: none"> 1. Normal expansion and contraction of metal parts during periods of heat-up and cool-down. 2. Sediment buildup on or around the elements. 3. The heat pump compressor or fan running. 	<ol style="list-style-type: none"> 1. No action required. 2. Replace element (see "Element Testing and Replacement", page 18). 3. No action required.

TROUBLESHOOTING CHART

PROBLEM	POSSIBLE CAUSE(S)	CORRECTIVE ACTION
DRIP FROM TEMPERATURE & PRESSURE RELIEF VALVE	<ol style="list-style-type: none"><li data-bbox="457 283 932 317">1. Excessive water pressure<li data-bbox="457 384 932 438">2. Add or service a thermal expansion tank.<li data-bbox="457 438 932 472">3. Debris under valve seat.	<ol style="list-style-type: none"><li data-bbox="945 283 1484 384">1. Check water supply inlet pressure. If higher than 80 PSIG, install a pressure reducing valve. 50-60 PSIG is the recommended pressure.<li data-bbox="945 384 1484 438">2. See “New Installation Troubleshooting” section (page 11-12).<li data-bbox="945 438 1484 493">3. See “Drips from T&P Relief Valve Discharge Pipe” section (page 11).

ELEMENT TESTING AND REPLACEMENT

Testing the Element

- 1 With power to the water heater OFF, remove the upper element access panel, insulation and plastic cover.
- 2 Loosen the two (2) screws on the upper heating element and remove both power wires.
- 3 Set multimeter to Ohms and measure resistance between the two upper heating element screws (reading should be between 5 and 25 Ohms).
- 4 If the resistance reading is either below 5 Ohms or above 25 Ohms, replace upper element. If the element's resistance is good, proceed to next step.
- 5 Check for a grounded or shorted element using continuity or resistance as follows:

A. Place a test probe on one of the element terminals and the other test probe on the element flange or tank shell. Ensure a good connection.

B. If either test shows continuity, the element is grounded and should be replaced.

If either test shows less than infinite resistance or continuity, the element is grounded and should be replaced.

Replace the elements as required.

Replacing the Heating Element

⚠ WARNING! Working on an energized circuit can result in severe injury or death from electrical shock. Turn power off. Check wires with a non-contact circuit tester to make sure power is off. When you are finished, be sure all covers are secured to reduce the risk of fire and electric shock.

Steps for Replacing the Heating Element:

- 1 Turn the power to the water heater OFF.

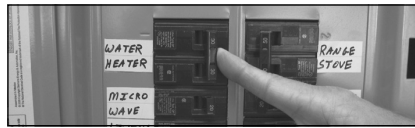

Figure 4 - Circuit Breaker

- 2 Open the electrical junction box on the side of the water heater. Using a non-contact circuit tester, check the power wires to make certain the power is OFF.



Figure 5 - Non-Contact Circuit Tester

- 3 Open a hot water faucet and let the hot water run until it is cool.



Figure 6 - Water Faucet

⚠ WARNING! Be sure the water runs cool before draining the tank to reduce the risk of scalding.

- 4 Connect a garden hose to the drain valve and place the other end of the hose in a drain or outside (or use buckets). Turn OFF the cold water valve that supplies the water heater. Open the drain valve on the water heater. Opening a hot water faucet will help the tank drain faster.

- 5 Remove the upper or lower access panel on the water heater, and then fold back the insulation and remove the plastic element/thermostat cover.



Figure 7 - Access Panel

- 6 With the tank drained and power off, remove the power wires from the element you intend to replace.
- 7 Remove the bad element using an element wrench.

ELEMENT TESTING AND REPLACEMENT

8 Make sure the new element is the correct replacement by referring to the water heater's data plate for voltage and wattage information.

9 Clean the threads in the tank opening with a rag. Insert the new element equipped with a rubber gasket. **NOTE:** Use a drop of hand dishwashing liquid to lubricate the gasket to help avoid damaging the gasket as it is being tightened. Tighten with an element wrench.

NOTICE: Do not turn power back on until the tank is completely full of water.

10 Refill the tank by opening the cold water supply valve. Make sure a hot water faucet is open and the drain valve is closed. Allow the hot water to run full for at least three minutes to make sure the tank has all the air removed and is completely full of water. Once you are certain the tank is completely full of water, close the hot water faucet.



Figure 8 - Drain Valve

11 Check the newly installed element for leaks. If a leak is present, tighten the element until the leak stops. If you cannot stop the leak by tightening the element, drain the tank and remove the element. Inspect the gasket for damage. If the gasket is damaged, replace the gasket and re-install the element.

12 Once the element is successfully installed and there are no leaks, replace the power wires, thermostat cover, insulation, and access panel. Make sure all wire connections are tight. Replace the cover on the electrical junction box.

13 Restore power to the water heater. It may take two hours for the tank to heat up.

Check/Reset Energy Cut Off Button

The Energy Cut Off (ECO) shuts off power to the water heater's elements if the temperature of the water in the tank gets too hot. If the ECO has tripped, you'll have no hot water. A tripped ECO can usually be reset. Investigate the cause of the overheating and repair the problem. Do not turn the power back on until the cause of the overheating has been identified and repaired.

To check the Energy Cut Off (ECO)

- Turn off power to the water heater.
- Press the red ECO reset button See figure 9, this page).
- The ECO was tripped if you hear a click when it is reset. In most cases a tripped ECO indicates that the tank overheated due to a problem with one of the elements. Check the upper and lower elements and replace if necessary (see page 18).
- The ECO was not tripped if you didn't hear a click. In that case, verify power to the upper terminals. If there is no power, refer back to the troubleshooting section, "no power". If there is power, check power to the lower terminals of the ECO. If there is no power to the lower terminals, replace the ECO.

Replacing the ECO

⚠ WARNING! Working on an energized circuit can result in severe injury or death from electrical shock. Turn power OFF. Check wires with a non-contact circuit tester to make sure power is OFF. When you are finished, be sure all covers are secured to reduce the risk of fire and electric shock.

To replace the ECO, you'll need the following tools and supplies:

- A non-contact circuit tester. Always turn power OFF and check with a non-contact circuit tester before working on the water heater.

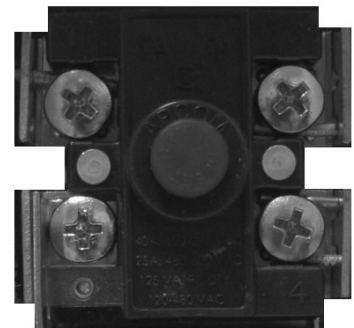

Figure 9 - ECO

- A business card to check the gap between the ECO and tank.
- Tape and a permanent marker to mark the wires
- A flat blade and a Phillips screwdriver

Follow these steps:

- 1** Turn the power OFF at the circuit breaker or remove fuses.

NOTICE: It is not necessary to drain the tank to replace an ECO.

ELEMENT TESTING AND REPLACEMENT

- 2 Open the electrical junction box the side of the water heater.
Using a non-contact circuit tester, check the power wires to make certain the power is OFF.

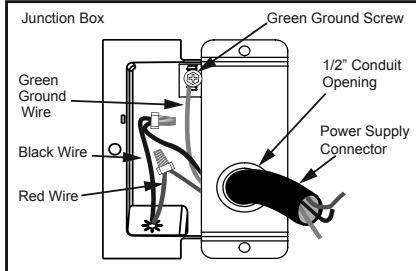

Figure 10 - Non-Contact Circuit Tester

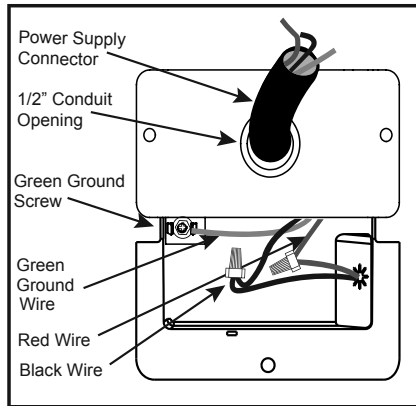

Figure 11 - 208V NEEA Junction Box

- 3 Remove the upper access panel on the water heater and carefully fold back the insulation and plastic element/ECO cover (See figure 12, this page).
- 4 Make sure the replacement ECO matches the original ECO.
- 5 Mark the wires with tape so you'll know how to put them back on.
- 6 Disconnect the wires from the bad ECO and remove the ECO from the metal mounting clip.
- 7 Install the new ECO in the metal mounting clip.

- 8 Make sure the new ECO fits snugly against the tank. If the new ECO does not fit snugly against the tank, bend the ECO mounting clip until the ECO fits tightly against the tank.
- 9 Attach the wires per previous marking (step 5) or by referencing wiring diagram on the water heater's label. Make sure all wire connections are tight.

- 10 Replace the plastic element/ECO cover, insulation, and access panel.
- 11 Replace the cover on the electrical junction box.
- 12 Restore power to the water heater. It may take two hours for the tank to heat up.



Figure 12 - Element Access Panel/ECO Compartment

T&P Relief Valve Maintenance

Read and follow the operating and annual maintenance instructions provided by the manufacturer of the T&P Relief Valve (yellow label attached to T&P Relief Valve). Minerals in the water can form deposits that cause the valve to stick or create blocked passages, making the T&P Relief Valve inoperative. Follow these guidelines:

- At least annually, operate the T&P Relief Valve manually to ensure the waterways are clear and the valve mechanism moves freely (above). Before operating the valve manually, check that it will discharge in a place for secure disposal. If water does not flow freely from the end of the discharge pipe, turn OFF the power to the water heater. Call a qualified person to determine the cause.

⚠ WARNING! Hot water will be released. Before operating the T&P relief valve manually, check that it will discharge in a safe place. If water does not flow freely from the end of the discharge pipe, turn the power to the water heater OFF. Call a qualified person to determine the cause.



Figure 13 - T&P Relief Valve

- At least every five years, a qualified person should inspect the T&P Relief Valve and discharge pipe.
- Damage caused by corrosive water conditions, mineral deposits, or other problems can only be determined when a qualified person removes and inspects the valve and its components.

REPLACING THE ANODE

- Note that a dripping T&P Relief Valve is usually caused by the home's water pressure being too high or the lack of a Thermal Expansion Tank. If your T&P Relief Valve drips refer to "Drips from T&P Relief Valve Discharge Pipe" section on page 11.

Air Filter Maintenance

To maintain optimal operation, check and clean the air filter as needed. The heater will monitor the heat pump operation status and indicate whether the filter should be cleaned. If the User Interface Module displays "SF" code, this indicates the filter should be cleaned or replaced with the following process (See exploded view of unit on last page for air filter location).

NOTE: Before attempting to clean or replace the air filter, turn OFF power to the water heater.

- To clean the filter, leave the filter in place and use a vacuum with a hose attachment to remove any dust or debris. If vacuuming does not remove all debris, remove the filter and clean with hand dishwashing soap and water or replace the filter.

To remove or replace air filter:

- Take the two tabs on the air filter and remove (slide) it from the top cover of the unit.
- Clean and reinstall or replace filter.
- Restore power to the water heater and turn the water heater on.

NOTE: The water heater may conduct a system diagnostic prior to operation.

Changing the Anode:

- Turn power OFF to the unit (at the breaker/fuse panel).
- Open a hot water faucet and let the hot water run until it's cool.
- Connect a garden hose to the drain valve and place the other end of the hose in a drain, outside or in buckets.
- Turn the cold water supply valve OFF and open the drain valve on the water heater.
- Open a hot water faucet to help the water in the tank drain faster.
- Remove the two screws from the top of the unit as well as all screws securing it to the shroud.
- Using a 1 - 1/16" six point deep well socket and an 18" extension, locate and remove the anode. Replace with new one.
NOTE: 66 and 80 gallon models have two anodes (figure 14)

- Replace the top (don't forget the top two screws), refill with water and re-establish power.



Figure 14 - Anode rods from new to (top) to partially depleted (middle) to fully depleted stages (bottom).

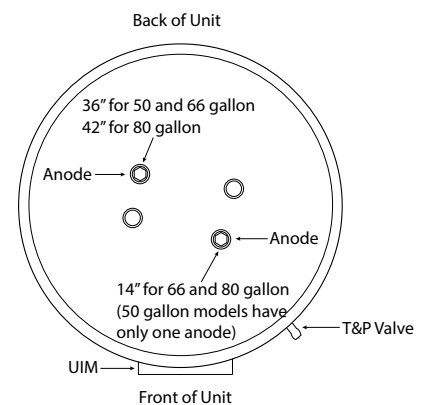
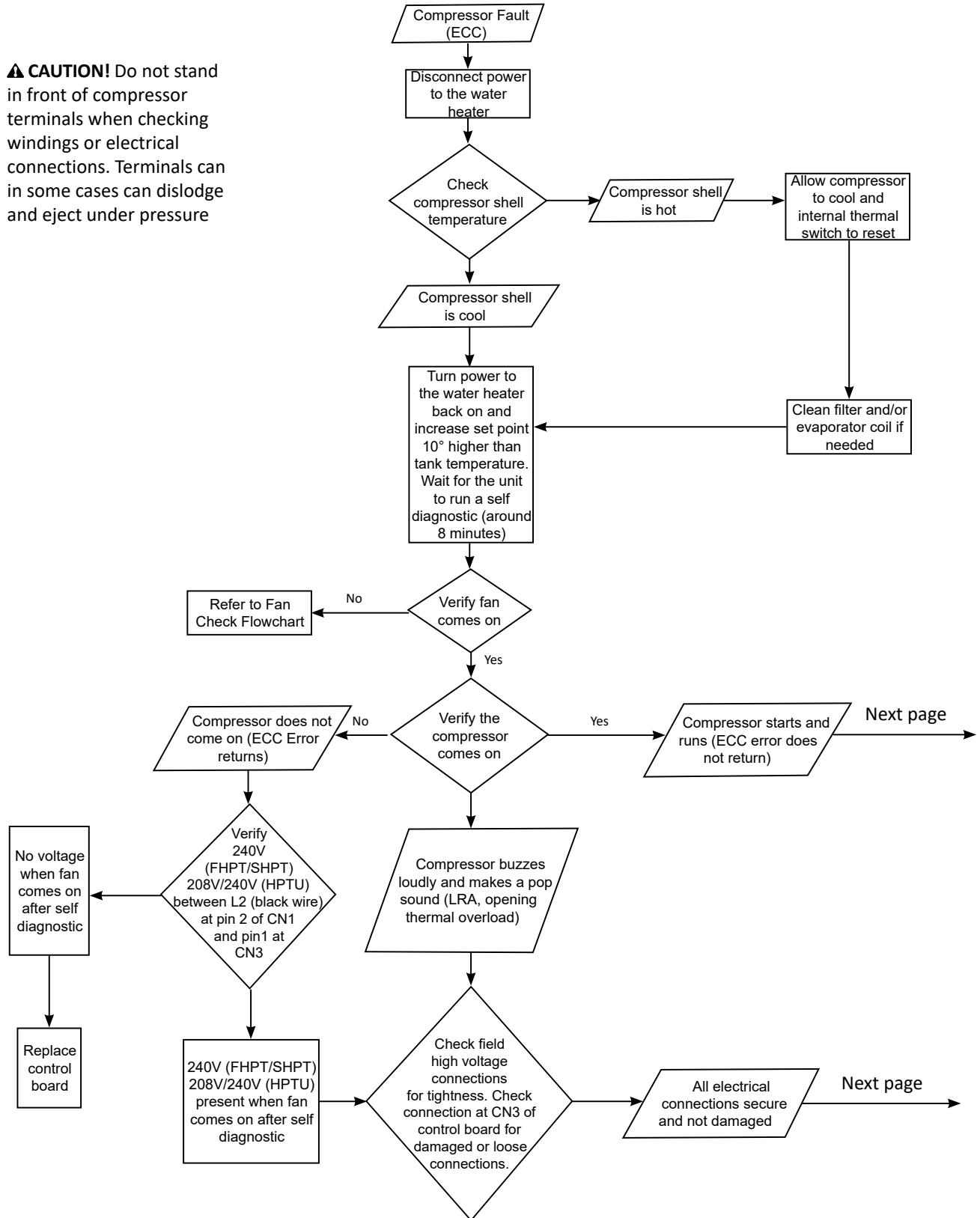

Figure 15 - Anode locations

COMPRESSOR CHECK FLOWCHART

⚠ CAUTION! Do not stand in front of compressor terminals when checking windings or electrical connections. Terminals can in some cases can dislodge and eject under pressure

SYSTEM CHECKS



COMPRESSOR CHECK FLOWCHART

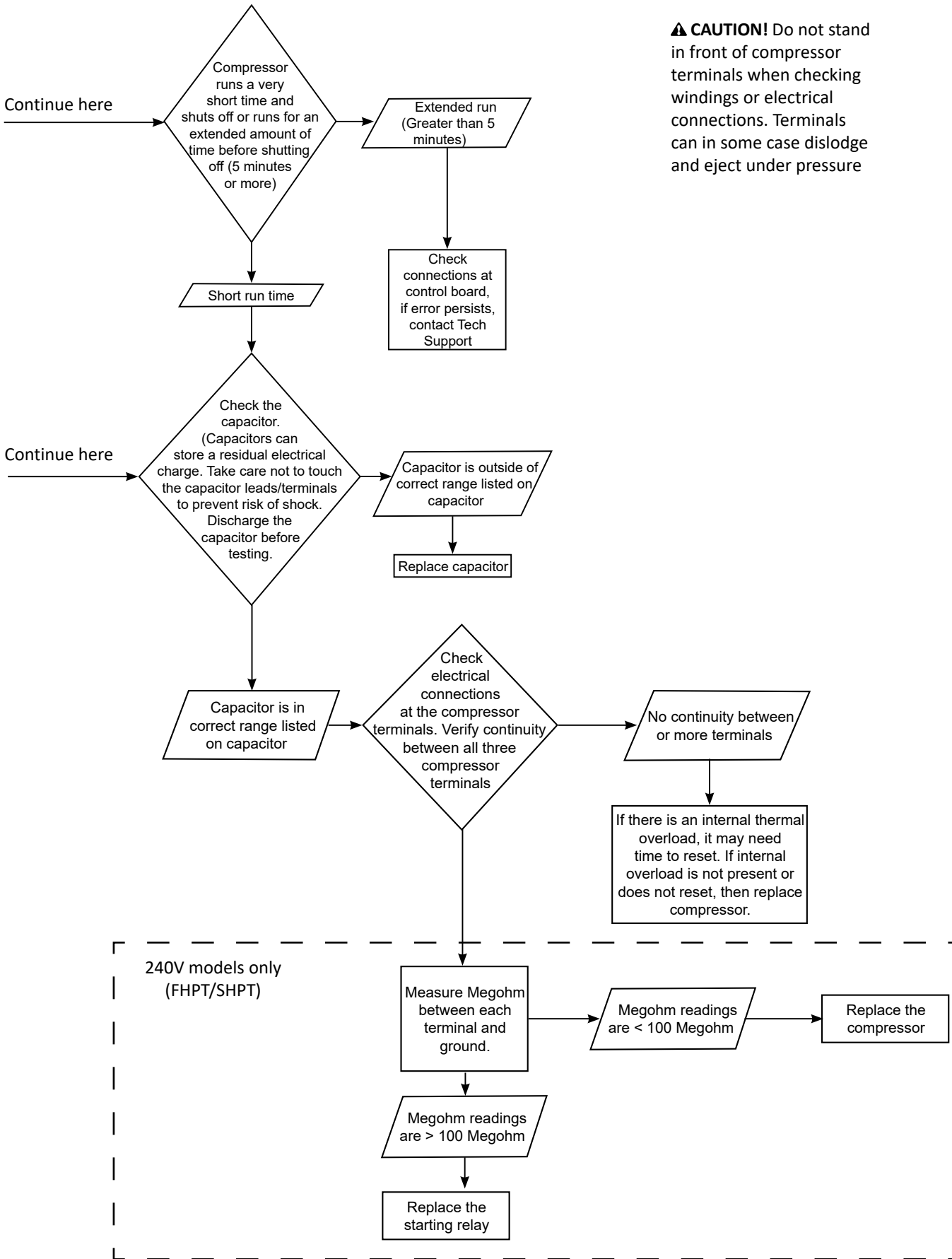

⚠ CAUTION! Do not stand in front of compressor terminals when checking windings or electrical connections. Terminals can in some case dislodge and eject under pressure

SYSTEM CHECKS

FAN CHECK FLOW CHART WITH CODE

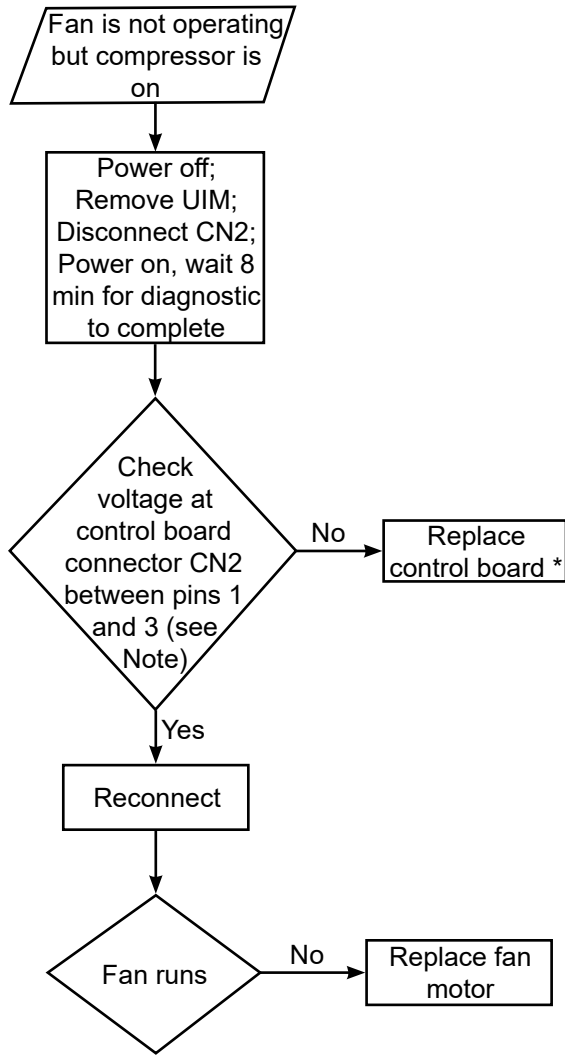

SYSTEM CHECKS

NOTE: The voltage is either 208V or 240V. Refer to “Power Cycling the Unit”, page 13

*If replacing the control board does not resolve the issue, contact technical support: 1-800-722-2101

CONTROL BOARD OVERVIEW

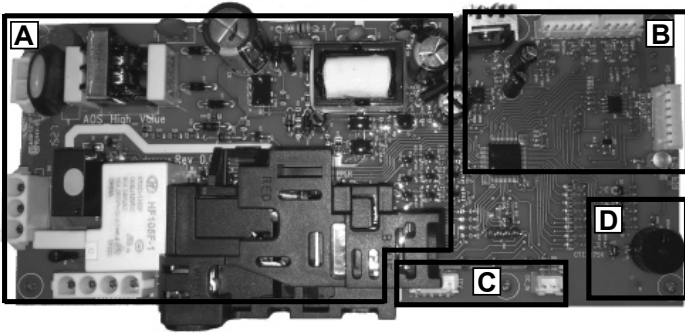

Figure 15: Front side of control board w/buzzer

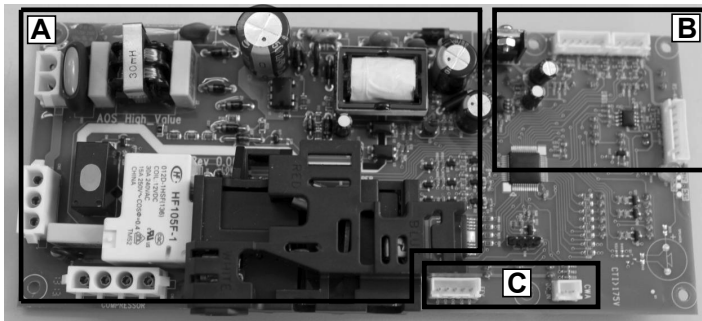

Figure 16: Front side of control board

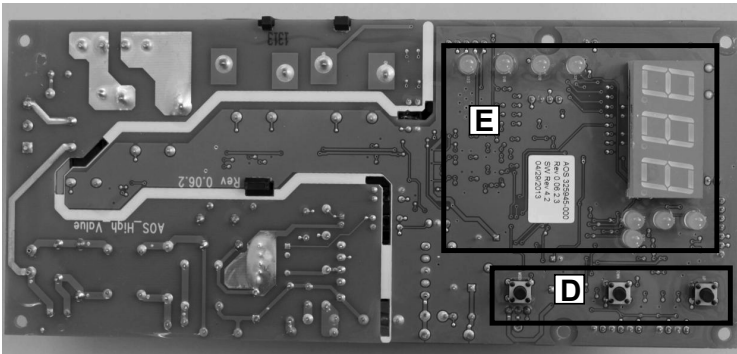

Figure 17: Back side of control board

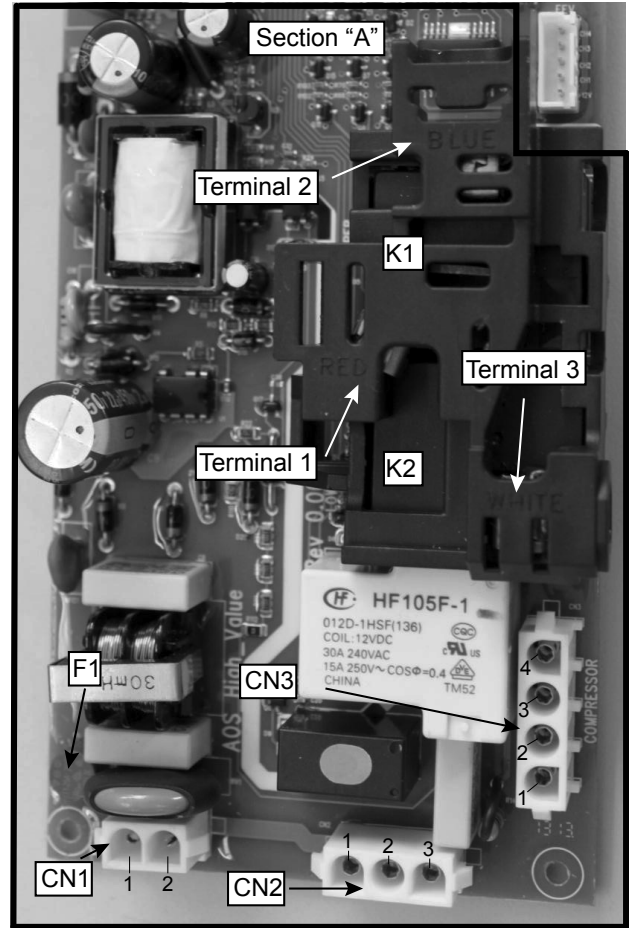

Figure 18: Section A

SECTION A

CN1 Line Power:

- Pin 1 - Control board power wire L1 (240Vac)
- Pin 2 - Control board power wire L2 (240Vac)

CN2 Fan:

- Pin 1 - Fan power L2
- Pin 2 - Unused
- Pin 3 - Fan power L1

CN3 Compressor:

- Pin 1 - Connects to L1 with ECO
- Pin 2 - Unused
- Pin 3 - Unused
- Pin 4 - Connects to Compressor power L1

F1:

- F1 (1.25 Amp, 250V. slow blow) fuses the L1 power leg coming to the control board

K1 Upper Element Relay:

- Terminal 1 - Connects to L1 with ECO
- Terminal 2 - Connects to upper heating element

K2 Lower Element Relay:

- Terminal 1 - Connects to L1 with ECO
- Terminal 3 - Connects to lower heating element

CONTROL BOARD OVERVIEW

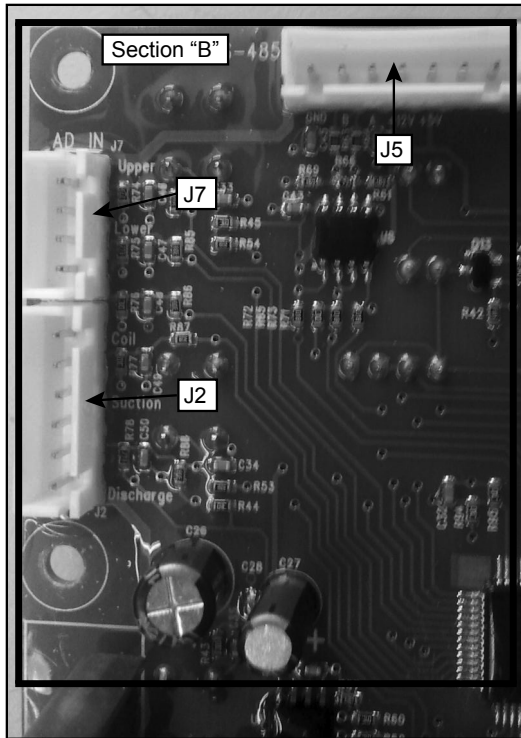

Figure 19 Section "B"

SECTION B

J7 Upper and Lower tank water temperature sensors:

- Pin 1 - Upper water temperature sensor on tank.
- Pin 2 - Upper water temperature sensor on tank.
- Pin 3 - Lower water temperature sensor on tank.
- Pin 4 - Lower water temperature sensor on tank.

J2 Temperature Sensors:

- Pin 1 - Coil Temperature sensor.
- Pin 2 - Coil temperature sensor.
- Pin 3 - Suction temperature sensor.
- Pin 4 - Suction temperature sensor.
- Pin 5 - Discharge temperature sensor.
- Pin 6 - Discharge temperature sensor.

J5 Communication:

- Pin 1 - Unused
- Pin 2 - Unused
- Pin 3 - +5V
- Pin 4 - +12V
- Pin 5 - Signal A+
- Pin 6 - Signal B+
- Pin 7 - Ground

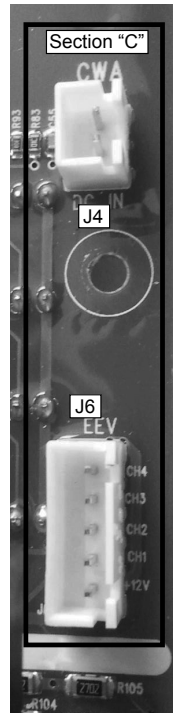

Figure 20 Section "C"

SECTION C

J4 Condensate Water Connection:

- Pin 1 - Condensate water alarm
- Pin 2 - Condensate water alarm

J6 EEV 9(Electronic Expansion Valve):

- Pin 1 - Connected to CH4 of EEV
- Pin 2 - Connected to CH3 of EEV
- Pin 3 - Connected to CH2 of EEV
- Pin 4 - Connected to CH1 of EEV

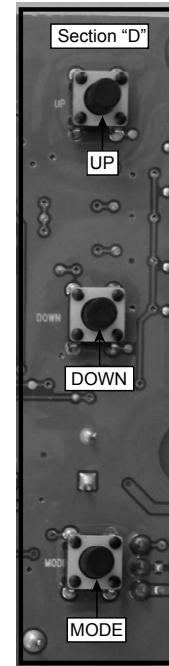
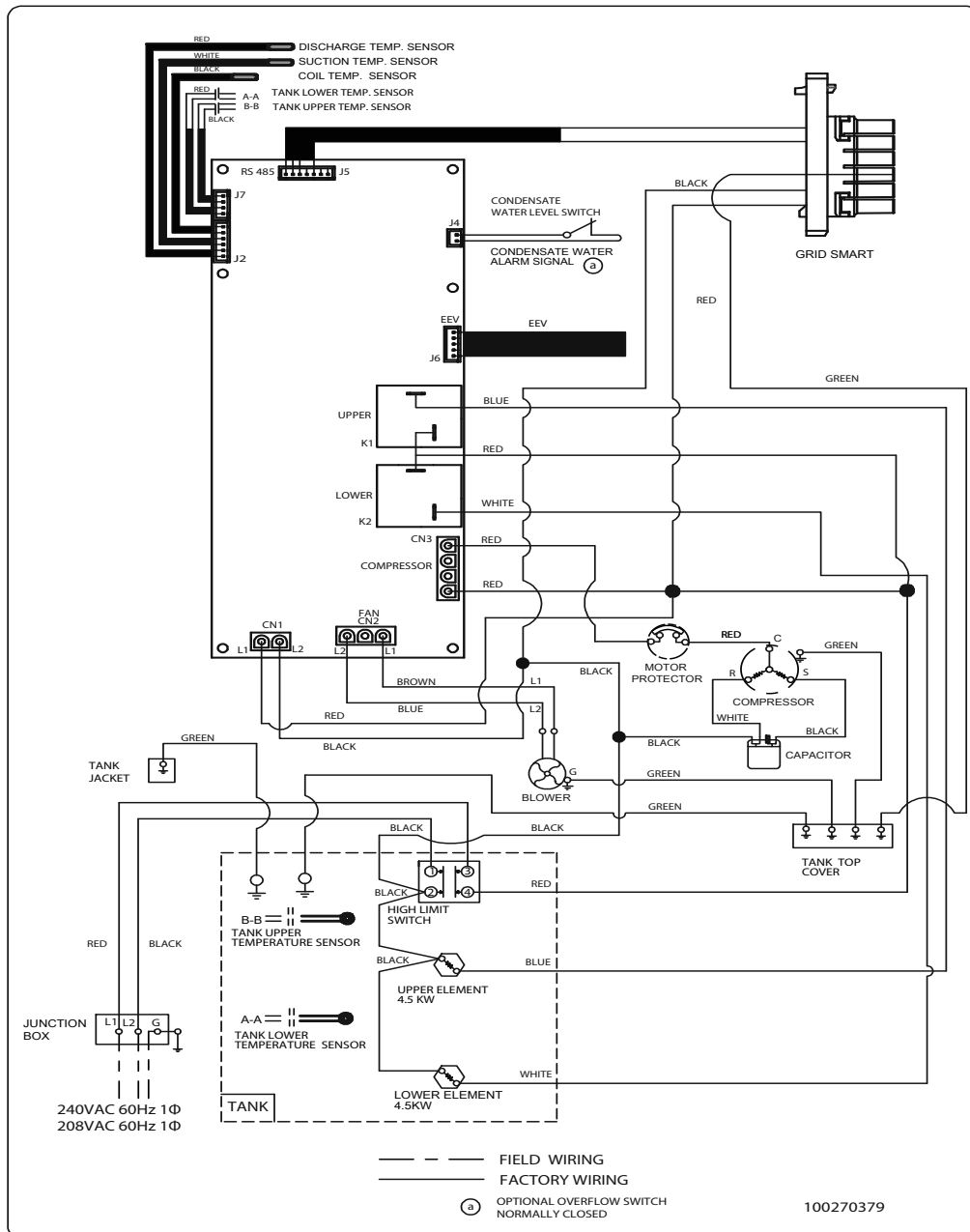

Figure 21 Section "D"

WIRE DIAGRAMS

NEEA Wire Diagram:



WIRE DIAGRAMS

208/240 Volt Wire Diagram:

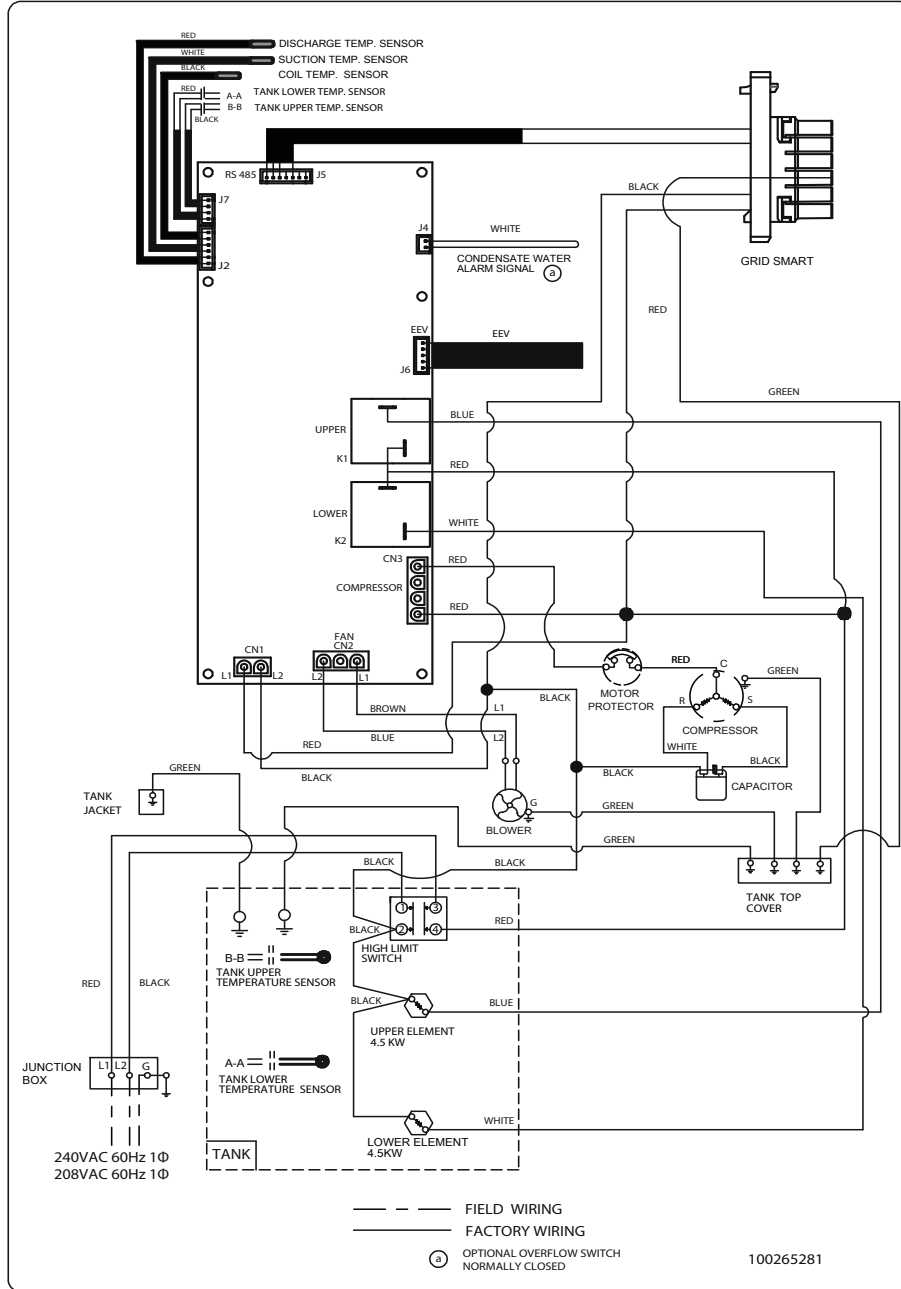

WIRE DIAGRAMS

240V Wire Diagram:

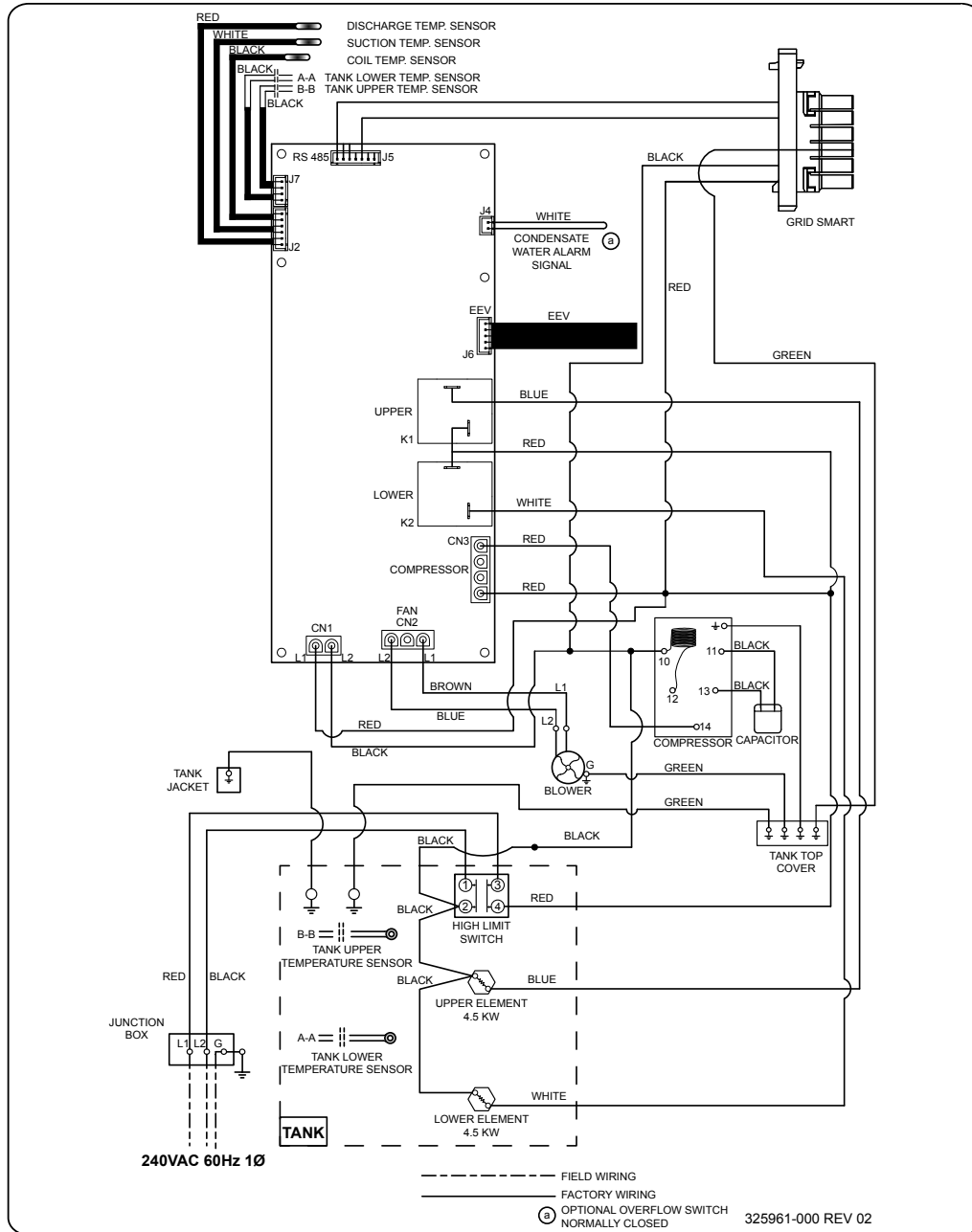

REPAIR PARTS ILLUSTRATION

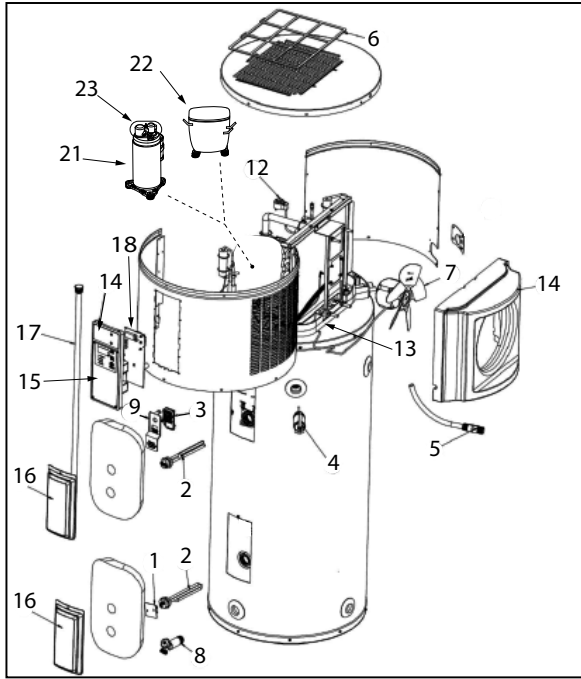

REPAIR PARTS

Repair parts may be ordered through your plumber, local distributor, home improvement center. When ordering repair parts always give the following information:

1. Model, serial and product number
2. Item number
3. Parts description

Table 1. 240V Models

18	Control Board, 240V	100263334
19	Start Capacitor*	100113138
20	Relay*	100191859
22	240V Compressor	100083556

Table 2. 208V/240V Models

18	Control Board, 208V & 240V	100263227
19	Run Capacitor*	100261846
21	208V Compressor	100261797
23	Thermal Overload Kit	100270597

*Not shown

ITEM NO.	PARTS DESCRIPTION	PART NUMBER
1	Personnel Protector	100109599
2	Element (4500 Watts)	100108283
3	Energy Cut-Off (ECO) Switch	100112568
4	Temperature & Pressure Relief Valve (T&P)	100108455
5	J-Tube (at hot water outlet) 11.25" for 50 gallon	100113131
5	J-Tube (at hot water outlet) 14.25" for 66 and 80 gallon	100228155
6	Air Filter	100113133
7	Fan Assembly	100113134
8	Drain Valve - Brass - 2 inch	100108666
9	Personnel Protector	100148769
10	Ambient / Coil / Discharge Temperature Sensor Assembly*	100113135
11	Upper / Lower Tank Temperature Sensor Assembly*	100113136
12	Electronic Expansion Valve Coil	100113137
13	Condensate Drain Pan	100084119
14	Smart Grid Cover	100075293
15	UIM Front Cover Assembly (No control board)	100263335
16	Element Access Panel	100109599
17	Anode (36" for 50 and 66 gallon models)**	100108660
17	Anode (14" for 66 and 80 gallon models)**	100108677
17	Anode (42" for 80 gallon models)**	100108660
17	Anode (Universal Link Style) Magnesium**	100110784
17	Anode (Universal Link Style) Aluminum**	100110627

*Not shown

**For anode locations, see figure 15 on page 20

NOTES

© 01/17/2019 All Rights Reserved



Lochinvar[®]
HIGH EFFICIENCY BOILERS & WATER HEATERS

Lochinvar, LLC
300 Maddox Simpson Parkway
Lebanon, Tennessee 37090
P: 615.889.8900 / F: 615.547.1000 • Lochinvar.com