

LECTRUS™

Installation & Operation Manual Models: KEB0015 - KEB0150

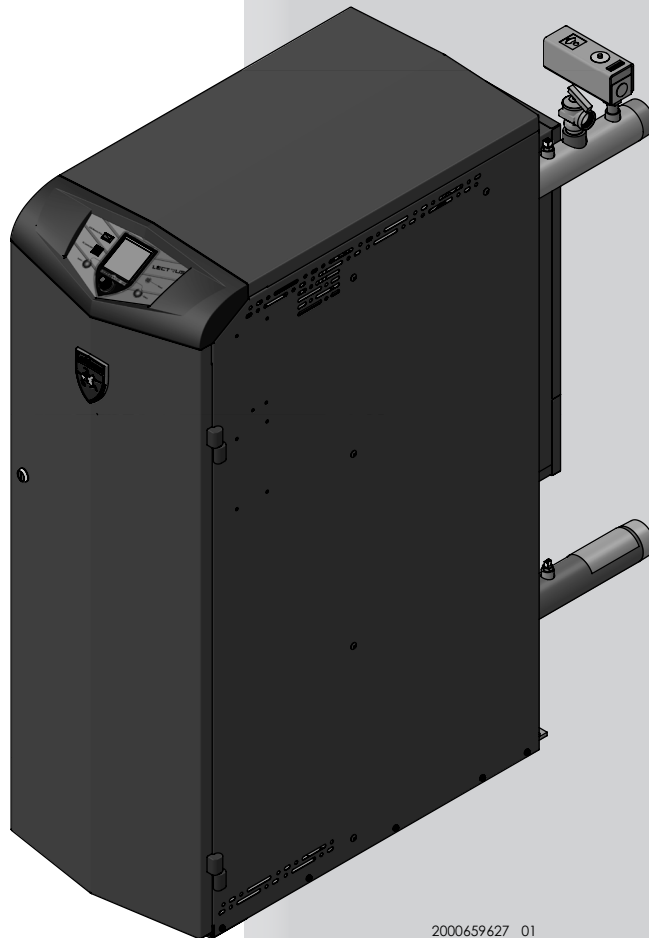

2000659627 01



Lochinvar®
HIGH EFFICIENCY BOILERS & WATER HEATERS

WARNING

This manual must only be used by a qualified heating installer / service technician. Read all instructions, including this manual and the Lectrus Service Manual, before installing. Perform steps in the order given. Failure to comply could result in severe personal injury, death, or substantial property damage.





Save this manual for future reference.

Contents

HAZARD DEFINITIONS	2	4. FIELD WIRING	
PLEASE READ BEFORE PROCEEDING	3	Line Voltage Connections	24
THE LECTRUS -- HOW IT WORKS	4-5	Low Voltage Connections	24
RATINGS	6	Wiring of the Cascade.....	26-27
1. DETERMINE BOILER LOCATION		5. STARTUP	33-40
Provide Air Openings to Room	7-8	6. OPERATING INFORMATION	
Flooring and Foundation	9	General.....	41
2. PREPARE BOILER		Cascade	45
Remove Boiler from Wood Pallet.....	10	Sequence of Operation	46-48
3. HYDRONIC PIPING		Lectrus Control Module	49
System Water Piping Methods.....	11	Status Display Screens	50-51
Low Water Cutoff Device	11	7. MAINTENANCE	
Chilled Water System.....	11	Maintenance and Annual Startup.....	52
Freeze Protection Fluids	11	8. DIAGRAMS	
Corrosive Contaminants and Sources	11	Wiring Diagram	56-60
General Piping Information	12	Ladder Diagram	61-63
Relief Valve Installation	12	Revision Notes	Back Cover
Near Boiler Piping Components.....	13		
Circulator Sizing	13		
Near Boiler Piping Connections	14-16		
Piping Diagrams	18-23		

Hazard definitions

The following defined terms are used throughout this manual to bring attention to the presence of hazards of various risk levels or to important information concerning the life of the product.

-  **DANGER** DANGER indicates an imminently hazardous situation which, if not avoided, will result in death or serious injury.
-  **WARNING** WARNING indicates a potentially hazardous situation which, if not avoided, could result in death or serious injury.
-  **CAUTION** CAUTION indicates a potentially hazardous situation which, if not avoided, may result in minor or moderate injury.
-  **CAUTION** CAUTION used without the safety alert symbol indicates a potentially hazardous situation which, if not avoided, may result in property damage.
-  **NOTICE** NOTICE indicates special instructions on installation, operation, or maintenance that are important but not related to personal injury or property damage.

Please read before proceeding

⚠ WARNING

Installer – Read all instructions, including this manual and the Lectrus Service Manual, before installing. Perform steps in the order given.

User – This manual is for use only by a qualified heating installer/service technician. Refer to the User's Information Manual for your reference.

Have this boiler serviced/inspected by a qualified service technician, at least annually.

Failure to comply with the above could result in severe personal injury, death, or substantial property damage.

NOTICE

When calling or writing about the boiler – Please have the boiler model and serial number from the boiler rating plate.

Consider piping and installation when determining boiler location.

Any claims for damage or shortage in shipment must be filed immediately against the transportation company by the consignee.

Factory warranty (shipped with unit) does not apply to units improperly installed or improperly operated.

⚠ WARNING

Failure to adhere to the guidelines on this page can result in severe personal injury, death, or substantial property damage.

⚠ WARNING

If the information in this manual is not followed exactly, a fire or explosion may result causing property damage, personal injury, or loss of life.

This appliance **MUST NOT** be installed in any location where gasoline or flammable vapors are likely to be present.

⚠ WARNING

DO NOT install units in rooms or environments that contain corrosive contaminants (see Table 3A on page 11). Failure to comply could result in severe personal injury, death, or substantial property damage.

When servicing boiler –

- To avoid electric shock, disconnect electrical supply before performing maintenance.
- To avoid severe burns, allow boiler to cool before performing maintenance.

Boiler operation –

- Should overheating occur do not turn off or disconnect electrical supply to circulator. Instead, shut off power to the boiler only.
- Do not use this boiler if any part has been under water. The possible damage to a flooded appliance can be extensive and present numerous safety hazards. Any appliance that has been under water must be replaced.

Boiler water –

- Thoroughly flush the system to remove debris. Use an approved pre-commissioning cleaner (see Start-Up Section), without the boiler connected, to clean the system and remove sediment. The pressure vessel can be damaged by build-up or corrosion due to sediment.
NOTE: Cleaners are designed for either new systems or pre-existing systems. Choose accordingly.

Freeze protection fluids –

- NEVER use automotive antifreeze. Use only inhibited propylene glycol solutions, which are specifically formulated for hydronic systems. Ethylene glycol is toxic and can attack gaskets and seals used in hydronic systems.

Grounding Instructions –

- This boiler must be grounded in accordance with the National Electrical Code and/or local codes. These must be followed in all cases. Failure to ground this boiler properly may also cause erratic control system operation on ELECTRONIC CONTROL.
- This boiler must be connected to a grounded metal, permanent wiring system, or an equipment grounding conductor must be run with the circuit conductors and connected to the equipment grounding terminal or lead on the boiler.

The Lectrus - How it works...

1. **Steel ASME rated pressure vessel**
Allows system water to flow around specially designed immersion heating elements for maximum heat transfer.
2. **Boiler outlet temperature sensor (limit rated)**
This sensor monitors boiler outlet water temperature (system supply). If selected as the controlling sensor, the control module adjusts boiler element power, so the outlet temperature is correct.
3. **Boiler inlet temperature sensor**
This sensor monitors return water temperature (system return). If selected as the controlling sensor, the control module adjusts the boiler element power, so the inlet temperature is correct.
4. **Manual Reset High Limit (MRHL)**
Immersion-type device for limiting the temperature of liquids in the boilers. The MRHL can be adjusted for field test and is equipped with a reset button.
5. **Electronic LCD display**
The display features a high-resolution liquid crystal screen, four (4) buttons, and a navigation dial. A serial and USB port support additional communication with the control.
6. **Water outlet (system supply)**
A 2" NPT water connection that supplies hot water to the system.
7. **Water inlet (system return)**
A 2" NPT water connection that returns water from the system to the pressure vessel.
8. **SMART SYSTEM Control Module**
The SMART SYSTEM Control responds to internal and external signals to meet heating demand.
9. **High voltage junction box**
The junction box contains the connection points for the line voltage power.
10. **Boiler drain connection**
A 3/4" NPT drain connection is provided for easy access in the event the boiler needs to be drained.
11. **Connection board**
The connection board provides easy access for connecting external low voltage devices and pumps.
12. **Wiring connections (knockouts)**
Conduit connection points for the low voltage and pump connection boards.
13. **Inspection opening**
Opening with a 3" NPT brass plug at the bottom of the boiler tank for easy inspection.
14. **Relief valve**
Protects the pressure vessel from an over pressure condition. The relief valve provided with the unit is set at 50 PSI.
15. **Line voltage wiring connection points**
Add knockouts for the field installed high voltage.
16. **Front panel**
Removable panel to gain access to the internal components.
17. **Power switch**
Turns 120 VAC ON/OFF to the boiler.
18. **Transformer**
The transformer provides 24VAC power to the low water cut-off board.
19. **High limit sensor (housed with the outlet temperature sensor)**
Device that monitors the outlet water temperature. If the temperature exceeds its setting, the integrated control will break the control circuit, shutting the boiler down.
20. **Low water cutoff probe (LWCO)**
Protects the pressure vessel from overheating, by ensuring adequate water is supplied to the boiler. In the event of inadequate water levels, the boiler will shut down.
21. **Reset switch**
Reset switch for the low water cutoff. Hold the switch for 10 seconds to reset.
22. **Test switch**
The test switch permits manual triggering of the LWCO safety circuit to test the contacts and evaluate the integrity of the circuit. Hold the switch for 10 seconds to test.
23. **Transformer (Control)**
The transformer provides 120VAC to the integrated control and other sub system.
24. **Modulation control board (MCB)**
The module fine-tunes the energy given to the triac(s) for linear control of the boiler. It controls the element banks and in what order they are activated.
25. **Top cover**
Allows access to the elements, the LWCO probe, the air purge, and the triacs.
26. **Electric elements**
They are activated depending on the demands. Quantity depends on the model.
27. **Triac boards**
A board that translates a low voltage signal to increase or decrease the power to an element.

*For factory installed options, consult the Lectrus Service Manual.

The Lectrus - How it works... (continued)

Models 0015 - 0150

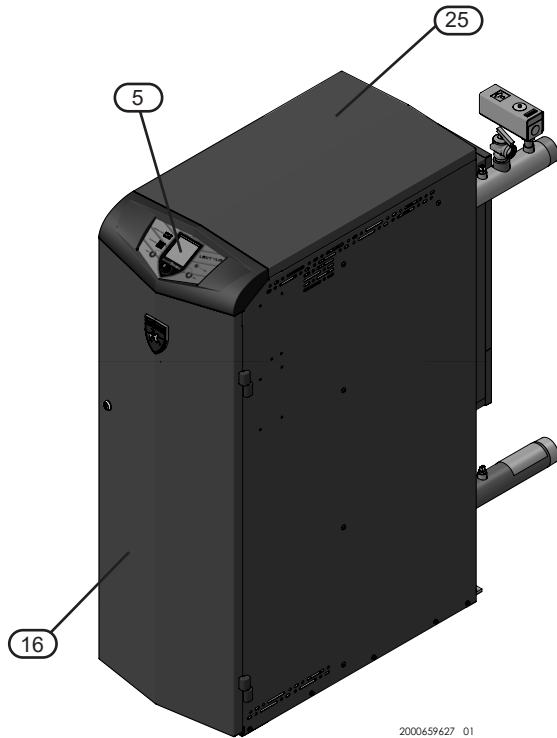

2000659627 01

Front View

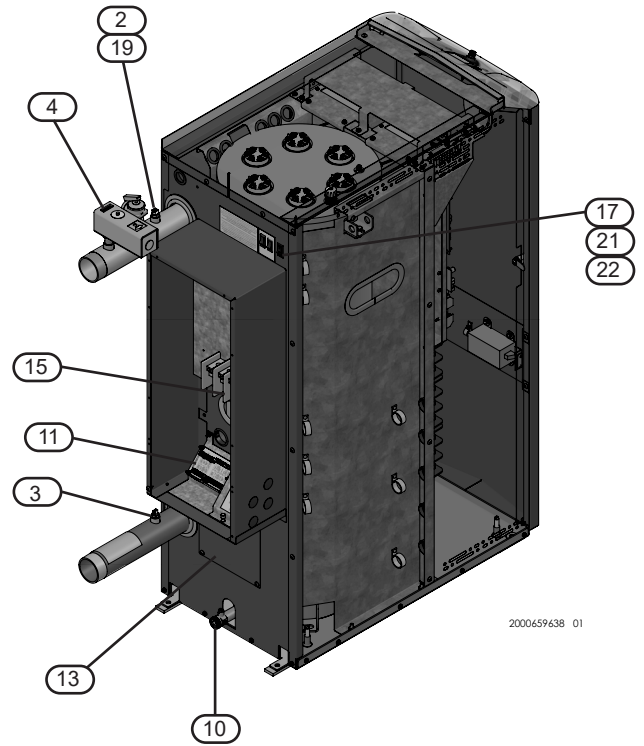

2000659638 01

Rear View

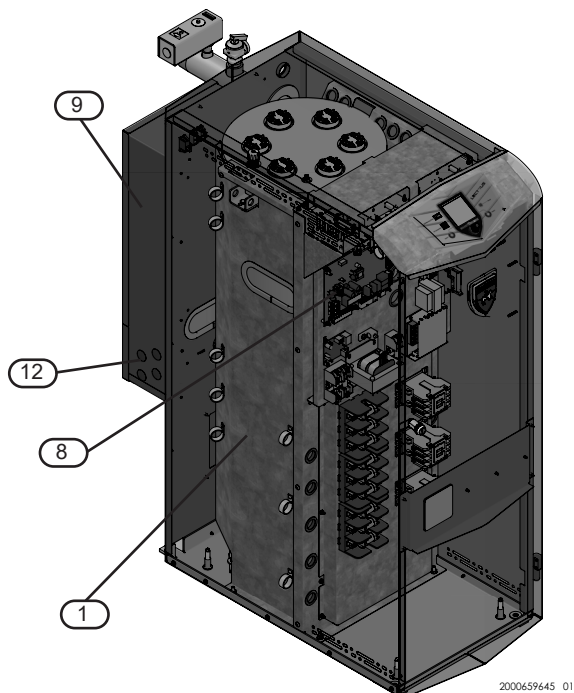

2000659645 01

Left Side (inside unit)

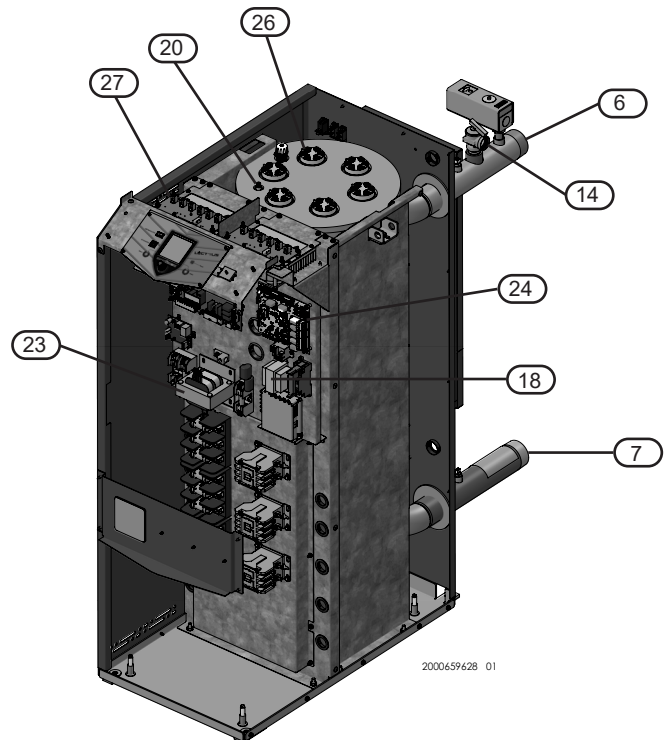

2000659628 01

Right Side (inside unit)

Ratings



LECTRUS BOILER SPECIFICATIONS				
Model	Input KW		Boiler Water Content (Gal)	Water Connections
	Min	Max		
KEB0015-	0.8	15	17.6	2"
KEB0030-	0.8	30	17.6	2"
KEB0045-	0.8	45	17.6	2"
KEB0060-	0.8	60	17.6	2"
KEB0075-	0.8	75	17.6	2"
KEB0090-	1.6	90	17.6	2"
KEB0105-	1.6	105	32	2"
KEB0120-	1.6	120	32	2"
KEB0135-	1.6	135	32	2"
KEB0150-	1.6	150	32	2"

NOTICE

Maximum allowed working pressure is located on the rating plate.

NOTICE

For all wiring connections, please refer to Table 4A.

Note:

Lectrus boilers comply with the requirements of CSD-1 Section CW-400 requirements as a temperature operation control. The manual reset high limit provided with the Lectrus is listed to UL 60730-1 and UL 60730-2-9.

1 Determine boiler location

Installation must comply with:

- Local, state, provincial, and national codes, laws, regulations, and ordinances.
- National Electrical Code.
- For Canada only: B149.1 Installation Code, CSA C22.1 Canadian Electrical Code Part 1 and any local codes.

Before locating the boiler, check:

1. Check for nearby connection to:
 - System water piping
 - Electrical power
2. Locate the appliance so that if water connections should leak, water damage will not occur. When such locations cannot be avoided, it is recommended that a suitable drain pan, adequately drained, be installed under the appliance. Under no circumstances is the manufacturer to be held responsible for water damage in connection with this appliance, or any of its components.
3. Check area around the boiler. Remove any combustible materials, gasoline, and other flammable liquids.



WARNING Failure to keep boiler area clear and free of combustible materials, gasoline, and other flammable liquids and vapors can result in severe personal injury, death, or substantial property damage.

4. The Lectrus must be installed so that control system components are protected from dripping or spraying water or rain during operation or service.
5. If a new boiler will replace an existing boiler, check for and correct system problems, such as:
 - System leaks causing oxygen corrosion or pressure vessel damage from hard water deposits.
 - Incorrectly sized expansion tank.
 - Lack of freeze protection fluids in boiler water causing system and boiler to freeze and leak.
 - Debris left from existing piping, if not flushed and cleaned with an appropriate cleaner.
6. Check around the boiler for any potential air contaminants that could risk corrosion to the boiler or the boiler room air supply (see Table 1A on page 10). Prevent room air for cabinet cooling contamination. Remove any of these contaminants from the boiler area.



WARNING DO NOT install units in rooms or environments that contain corrosive contaminants (see Table 3A on page 11). Failure to comply could result in severe personal injury, death, or substantial property damage.

DO NOT install the boiler in a room likely to freeze.



This appliance is certified as an indoor appliance. Do not install the appliance outdoors or locate where the appliance will be exposed to freezing temperatures. Do not install the appliance where condensation may form on the inside or outside of the appliance, or where condensation may fall onto the appliance. Failure to install the appliance indoors could result in severe personal injury, death, or substantial property damage.

Provide clearances:

Clearances from combustible materials

1. Hot water pipes—at least 1/4" (6 mm) from combustible materials.
2. See FIG.'s 1-1 and 1-2 on page 8 for other clearance minimums.

Clearances for service access

1. See FIG.'s 1-1 and 1-2 on page 8 for recommended service clearances. If you do not provide the minimum clearances shown, it may not be possible to service the boiler without removing it from the space.

1 Determine boiler location *(continued)*

Figure 1-1 Minimum Required Clearances - Alcove

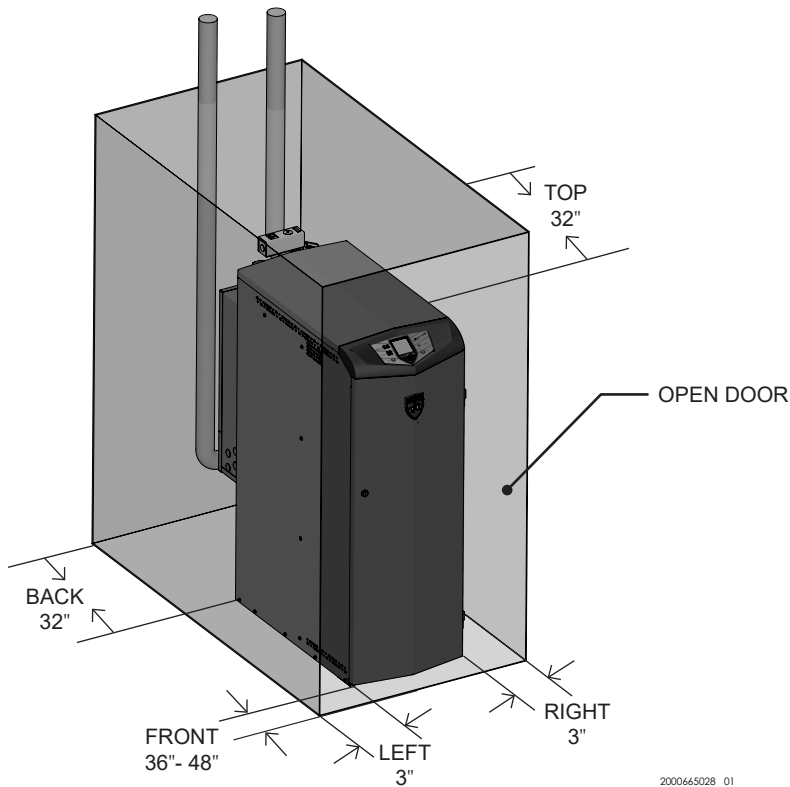
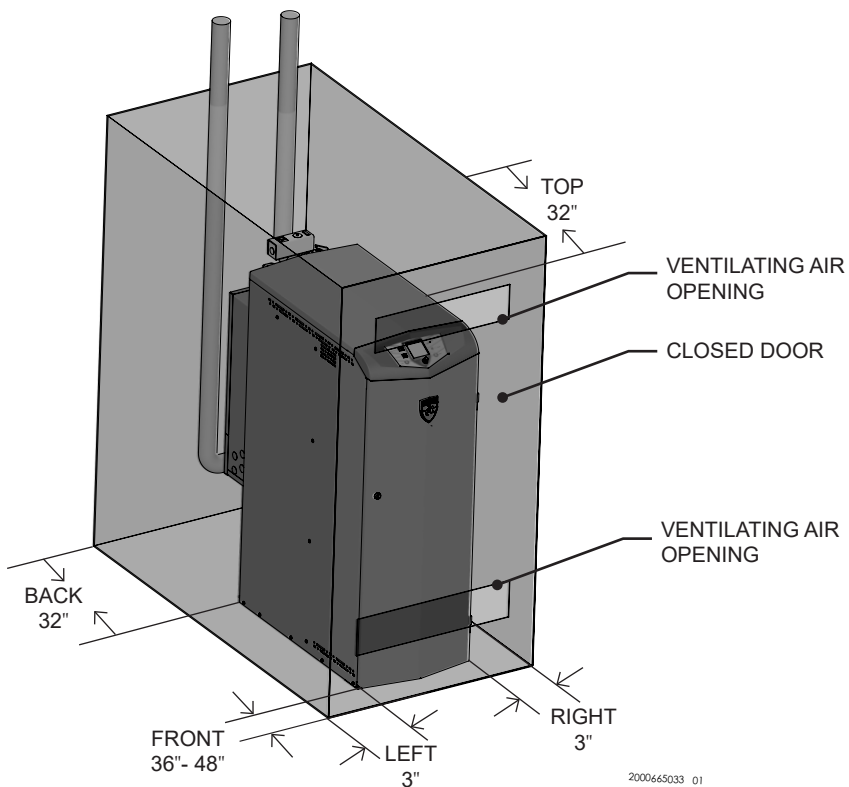

Figure 1-2 Minimum Required Clearances - Closet



1 Determine boiler location *(continued)*

MINIMUM service clearances

FRONT	- 36" to 48" (92 - 122 cm)*
TOP	- 32" (82 cm)
REAR	- 36" to 48" (92 - 122 cm)
LEFT	- 3" (8 cm)**
RIGHT	- 3" (8 cm)**

* - Refer to the NEC section 110.26 and the Table 110.26 (A) (1) Working Spaces for minimum clear distance based on the condition applicable to your installation.

** - The minimum clearances on each side of the unit to promote warm air exhaust for the modulation fan(s) are 3" (8cm). Refer to the NEC section 110.26 (A)(2) for the minimum width of the working space in front of the boiler.

⚠ WARNING Do not install the boiler in an attic.

Failure to comply with the above warning could result in severe personal injury, death, or substantial property damage.

Flooring and foundation

Flooring

The Lectrus is approved for installation on combustible flooring but must never be installed on carpeting.

⚠ WARNING Do not install the boiler on carpeting even if foundation is used. Fire can result, causing severe personal injury, death, or substantial property damage.

If flooding is possible, elevate the boiler sufficiently to prevent water from reaching the boiler.

Storage

Electrical equipment can be damaged if exposed to adverse weather. The boiler should be stored inside. The electrical panel and controls should be covered with plastic throughout all construction to avoid accumulation of dust and moisture on the controls and load components. The contactors can be damaged by dust / dirt in the mechanism.

Table 1A Boiler Dimensions and Specifications

Model	Height	Width	Depth	Water Connection	Shipping Weight	Volume
0015 - 0090	47"	16 - 3/4"	41"	2" NPT	367 lbs	17.6 gal
0105 - 0150	47"	21 - 3/4"	45 - 1/2"	2" NPT	488 lbs	32 gal

2 Prepare boiler

Remove boiler from wood pallet

1. After removing the outer shipping carton from the boiler, remove the parts box.
2. To remove the boiler from the pallet (after removing the front door):
 - a. Remove the two (2) lag bolts from inside the front of the boiler (FIG. 2-1).
 - b. Remove the two (2) lag bolts on the rear of the boiler.
 - c. Before removing the boiler from the pallet or moving the boiler.

NOTICE

Do not drop the boiler or bump the jacket on the floor or pallet. Damage to the boiler can result.

Figure 2-1 Boiler Mounted on Shipping Pallet

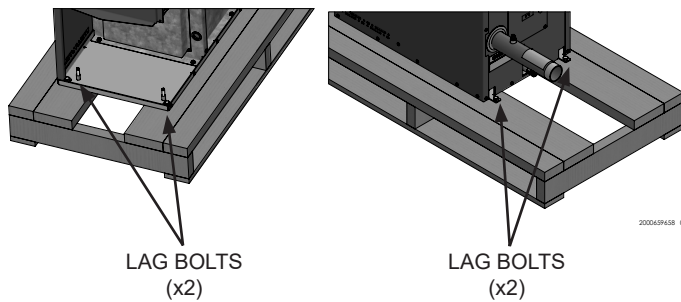

3 Hydronic piping

System water piping methods

The Lectrus is designed to function in a closed loop system pressurized to not less than 12 psi (83 kPa) (Non-metallic system piping must have an oxygen barrier to be considered a closed loop). A temperature and pressure gauges are included to monitor system pressure and outlet temperature and should be located on the boiler outlet.

It is important to note that the boiler has a minimal amount of pressure drop which must be accounted for when sizing the circulators. Each boiler installation must have an air elimination device, which will remove air from the system. Install the boiler so it is protected from water (dripping, spraying, etc.) during appliance operation or basic service of circulator replacement, valves, and others.

Observe a minimum of 1/4 inch (6 mm) clearance around all un-insulated hot water pipes when openings around the pipes are not protected by non-combustible materials.

Low water cutoff device

This boiler comes equipped with a low water cutoff device. On a boiler installed above radiation level, some states and local codes require a second low water cutoff device at the time of installation.

Chilled water system

If the boiler supplies hot water to heating coils in air handler units, flow control valves or other devices must be installed to prevent gravity circulation of boiler in the coils during the cooling cycle. A chilled water medium must be piped in parallel with the boiler.

Freeze protection fluids

Freeze protection fluids for new or existing systems must use glycol that is specially formulated for this purpose. This includes inhibitors, which prevent the glycol from attacking the metallic system components. Make certain to check that the system fluid is correct for the glycol concentration and inhibitor level. The system should be tested at least once a year and as recommended by the producer of the glycol solution. Allowance should be made for the expansion of the glycol solution in the system piping.

WARNING

Use only inhibited propylene glycol solutions, which are specifically formulated for hydronic systems. Ethylene glycol is toxic and can attack gaskets and seals used in hydronic systems.

Table 3A Corrosive Contaminants and Sources

Products to avoid:
Spray cans containing chloro/fluorocarbons
Permanent wave solutions
Chlorinated waxes/cleaners
Chlorine-based swimming pool chemicals
Calcium chloride used for thawing
Sodium chloride used for water softening
Refrigerant leaks
Paint or varnish removers
Hydrochloric acid/muriatic acid
Cements and glues
Antistatic fabric softeners used in clothes dryers
Chlorine-type bleaches, detergents, and cleaning solvents found in household laundry rooms
Adhesives used to fasten building products and other similar products
Areas likely to have contaminants
Dry cleaning/laundry areas and establishments
Swimming pools
Metal fabrication plants
Beauty shops
Refrigeration repair shops
Photo processing plants
Auto body shops
Plastic manufacturing plants
Furniture refinishing areas and establishments
New building construction
Remodeling areas
Garages with workshops

3 Hydronic piping

General piping information

IMPORTANT

All boiler piping must contain an oxygen barrier. This will help prevent any excess oxygen from entering the system.

Basic steps are listed below along with illustrations on the following pages (FIG.'s 3-4 through 3-9), which will guide you through the installation of the Lectrus (reference FIG.'s 3-2A and 3-2B).

1. Connect the system return marked "Inlet".
2. Connect the system supply marked "Outlet".
3. Install purge and balance valve or shutoff valve and drain on system return to purge air out of each zone.
4. Install a backflow preventer on the cold feed make-up water line.
5. Install a pressure reducing valve on the cold feed make-up water line, (15 psi (103 kPa) nominal). Check temperature and pressure gauge (shipped separately), which should read a minimum pressure of 12 psi (83 kPa).
6. Install a circulator as shown on the piping diagrams in this section. Make sure the circulator is properly sized for the system and friction loss.
7. Install an expansion tank on the system supply. Consult the tank manufacturer's instruction for specific information relating to tank installation. Size the expansion tank for the required system volume and capacity.
8. Install an air elimination device on the system supply.
9. Install a drain valve at the lowest point of the system. **Note:** The boiler cannot be drained completely of water without purging the unit with an air pressure of 15 psi (103 kPa).

NOTICE

If the boiler needs to be drained, the power must be turned OFF. This will prevent damage to the elements in the boiler.

10. This appliance is supplied with a relief valve sized in accordance with ASME Boiler and Pressure Vessel Code, Section IV ("Heating Boilers"). Pipe the discharge of the safety relief valve to prevent injury in the event of pressure relief. Pipe the discharge to a drain. Provide piping that is the same size as the safety relief valve outlet. Never block the outlet of the safety relief valve.

NOTICE

The relief valve, tee and any other necessary fittings are shipped in the install kit with the boiler and are to be field installed (FIG. 3-1).

11. Install a field supplied strainer/filter to prevent damage to the pressure vessel caused by debris entering from the system piping. When installing in a pre-existing system, a strainer/filter capable of removing debris left in the system is recommended.
12. Install a field supplied magnetic separator in the heating system return line as close as practical to the boiler per the manufacturer's instructions.

NOTICE

A magnetic separator is recommended when a unit is installed in a retrofit system, or a system containing steel and/or cast-iron pipe.

See the piping illustrations included in this section, FIG.'s 3-4 and 3-9 for suggested guidelines in piping the Lectrus.

NOTICE

Please note that these illustrations are meant to show system piping concept only, the installer is responsible for all equipment and detailing required by local codes.

Relief valve and temperature and pressure gauge installation

The boiler has a factory installed relief valve and manual reset high limit (MRHL). Note that if the MRHL has been factory installed in a horizontal position, it can be adjusted to a vertical position.

NOTICE

When installing the provided temperature and pressure gauge (T&P), be sure to use the tee and bushing provided with the T&P.

Figure 3-1 T & P Gauge Installation - Models 0015 - 0150

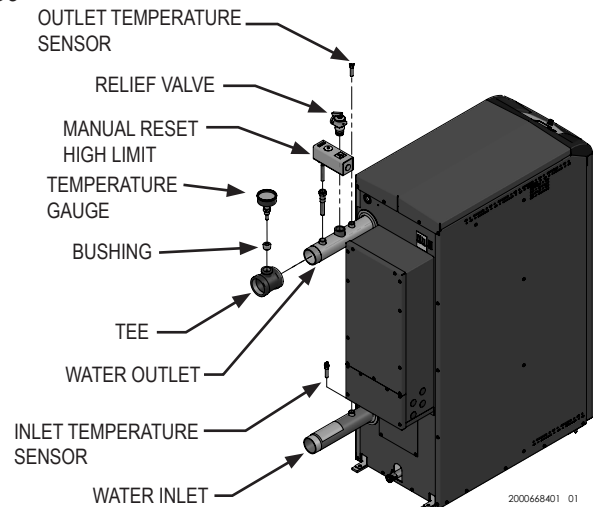

2000668401 01

3 Hydronic piping *(continued)*

Near boiler piping components

1. Boiler system piping:

Boiler system piping **MUST** be sized per the pipe requirements listed in Table 3C. Reducing the pipe size can restrict the flow rate through the boiler, causing inadvertent high limit shutdowns and poor system performance. Flow rates are based on a full flow application.

2. Boiler system circulating pump:

Field supplied. The boiler circulating pump should be based on system requirements.

3. Domestic hot water circulating pump:

Field supplied. The pump **MUST** be sized to meet the specified minimum flow requirements listed in FIG. 3-3. Consult the indirect water heater operating guide to determine flow characteristics for the selected product used.

4. Variable speed boiler circulator:

Lectrus boilers are capable of controlling a variable speed boiler circulator. Variable speed circulators **MUST** be sized to meet the specified minimum flow requirements listed in FIG. 3-3 on page 17 at full speed. To be used in primary/secondary systems only.

5. Boiler isolation valves:

Field supplied. Full port ball valves are required. Failure to use full port ball valves could result in a restricted flow rate through the boiler.

6. Check valves:

Field supplied. Check valves are recommended for installation as shown in FIG.'s 3-4 through 3-9. Failure to install check valves could result in a reverse flow condition during pump(s) off cycle.

7. Domestic indirect hot water isolation valves:

Field supplied. Full port ball valves are required. Failure to use full port ball valves could result in a restricted flow rate through the boiler.

8. Anti-scald mixing valve:

Field supplied. An anti-scald mixing valve is recommended when storing domestic hot water above 115°F (46°C).

9. Unions:

Field supplied. Recommended for unit serviceability.

10. Temperature and pressure gauge:

Factory supplied. The temperature and pressure gauge is shipped loose. It is the responsibility of the contractor to install the temperature and pressure gauge on the boiler water outlet.

11. Pressure relief valve:

Factory supplied. The pressure relief valve is sized to ASME specifications.

12. Boiler purge valve:

Field supplied. The boiler purge valve is used to remove entrapped air from the pressure vessel during start-up.

13. System temperature sensor:

Lochinvar supplies a system temperature sensor. The sensor is to be installed in the heating loop downstream from the boiler hot water piping and heating loop junction. The sensor should be located far enough downstream to sense system diluted water temperature.

14. Water Meter:

Field supplied. A water meter to monitor makeup water is recommended. Makeup water volume should not exceed 5% of total system per year.

15. Strainer/Filter:

Field supplied. Install a Y-strainer or equivalent multi-purpose strainer/filter just before the boiler pump at the inlet of the pressure vessel. This item is used to remove system debris from older hydronic systems and to protect newer systems.

16. Motorized isolation valve (optional):

Field supplied. A motorized isolation valve can be used to isolate the boiler from the system piping.

17. Magnetic Separator:

Field supplied. Install a magnetic separator in the heating system return line as close as practical to the boiler per the manufacturer's instructions.

Circulator sizing

The Lectrus pressure vessel does have a pressure drop, which must be considered in your system design. Refer to the graphs in FIG. 3-3 for pressure drop through the Lectrus pressure vessel.

3 Hydronic piping

Near boiler piping connections

Variable speed pump option

Variable speed pump setup

Before operation, ensure the following:

- Pump is set for an input signal of 0 - 10VDC by the dip switches on the pump control
- Pump is set for external signal control (if applicable)
- Pump is set for linear output (if applicable)
- If pump does not come equipped with a 0 - 10 VDC input option, an optional module will be required from the vendor

SMART SYSTEM

The Lectrus boiler has one heat demand and produces one set point temperature. Third party zone device managers will be required if installing in a system that require multiple zone temperatures. When using more than one temperature demand it is necessary to protect the lower temperature loop(s) from overheating.

CAUTION

The maximum allowable water flow rate through a single Lectrus boiler is 105 GPM. Exceeding this flow rate will result in damage to the pressure vessel and/or piping.

NOTICE

Reference Table 3C for the minimum recommended flow rate through a single Lectrus boiler at full fire to maintain a 80°F temperature rise. Reference Table 3B for the absolute minimum flow rate through a single Lectrus boiler.

Table 3B Absolute Minimum Flow Rate at Low Fire

ABSOLUTE MINIMUM FLOW RATE	
MODEL	FLOW RATE (GPM)
15 KW	1.6
30 KW	2.7
45 KW	3.8
60 KW	5.0
75 KW	6.2
90 KW	7.9
105 KW	2.7
120 KW	3.8
135 KW	5.0
150 KW	6.2
[Based on 80°F Temperature Rise]	

3 Hydronic piping *(continued)*

Figure 3-3 Pressure Drop vs. Flow

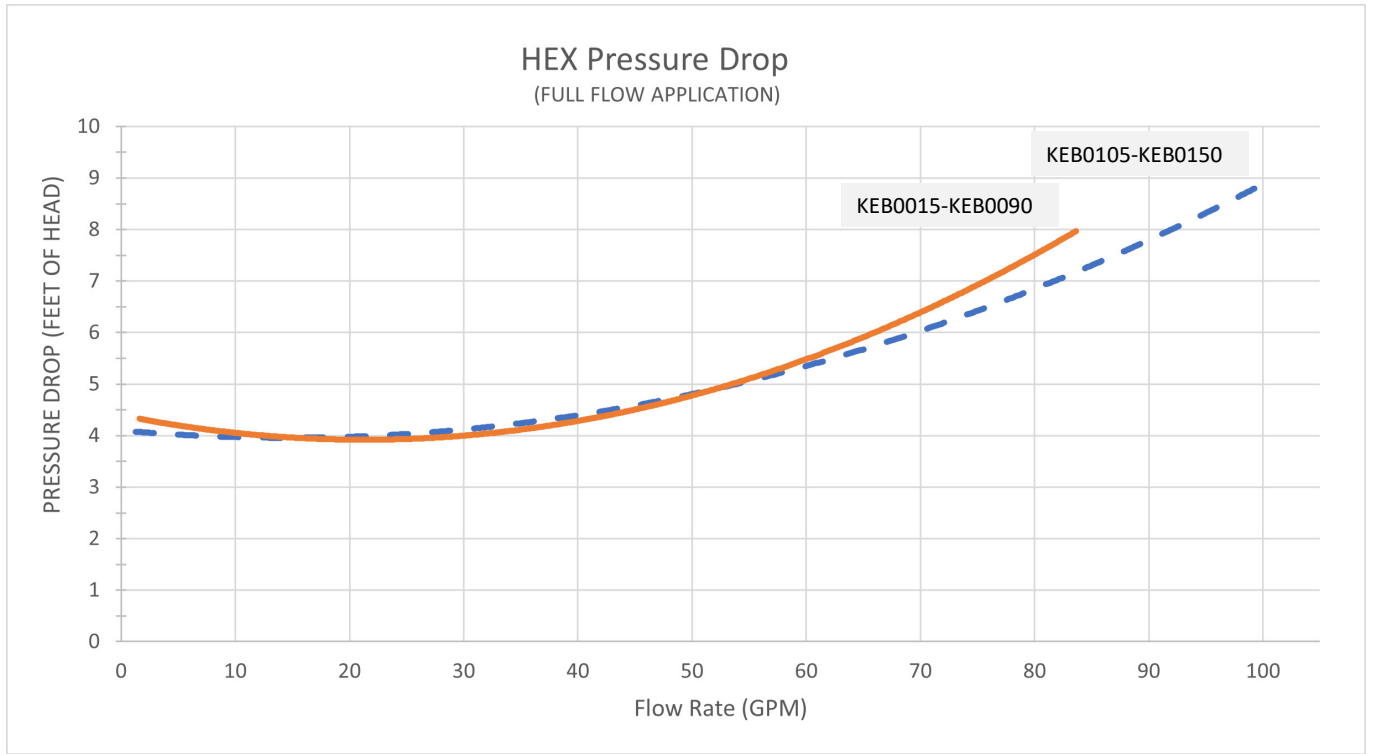

Table 3C Sizing Information for Temperature Rise Applications_10°F, 20°F, 30°F, and 40°F

TEMPERATURE RISE APPLICATIONS													
Model	MINIMUM PIPE SIZE	10°F		20°F		30°F		40°F		60°F		80°F	
		GPM	FT/HD	GPM	FT/HD	GPM	FT/HD	GPM	FT/HD	GPM	FT/HD	GPM	FT/HD
015	2"	11.0	3.3	5.4	3.3	3.3	3.6	2.4	3.6	1.7	3.8	1.3	4.3
030	2"	22.2	3.4	11.0	3.4	7.0	3.5	4.7	3.6	3.3	3.8	2.9	4.1
045	2"	35.7	3.9	16.0	3.5	10.8	3.5	7.9	3.6	5.5	3.9	4.5	4.2
060	2"	43.8	4.3	21.9	3.7	14.2	3.7	10.8	3.7	7.1	3.9	5.2	4.2
075	2"	56.4	5.1	27.1	3.9	18.1	3.8	13.1	3.8	9.0	4.2	7.1	4.7
090	2"	65.3	5.8	32.7	4.1	21.0	3.9	16.0	3.9	10.5	4.1	7.9	4.5
105	2"	73.6	6.3	37	4.3	25.7	4.0	18.9	3.9	12.4	4.1	9.2	4.4
120	2"	81.0	6.9	41.6	4.4	28.1	4.0	20.8	3.8	14.2	4.1	10.5	4.4
135	2"	90.7	7.9	45.7	4.7	31.1	4.2	23.8	4.0	15.7	4.1	11.8	4.5
150	2"	98.9	8.8	52.0	5.1	35.1	4.3	26.1	4.3	17.3	4.3	13.2	4.5

3 Hydronic piping

Figure 3-4 Multiple Boilers - Alternate - Fixed or Variable Flow Primary System Piping

Model	Number of Units						
	2	3	4	5	6	7	8
Manifold Pipe Sizes in Inches (mm)							
0015 to 0150	3 1/2 (89)	4 (102)	5 (127)	6 (152)	6 (152)	8 (203)	8 (203)

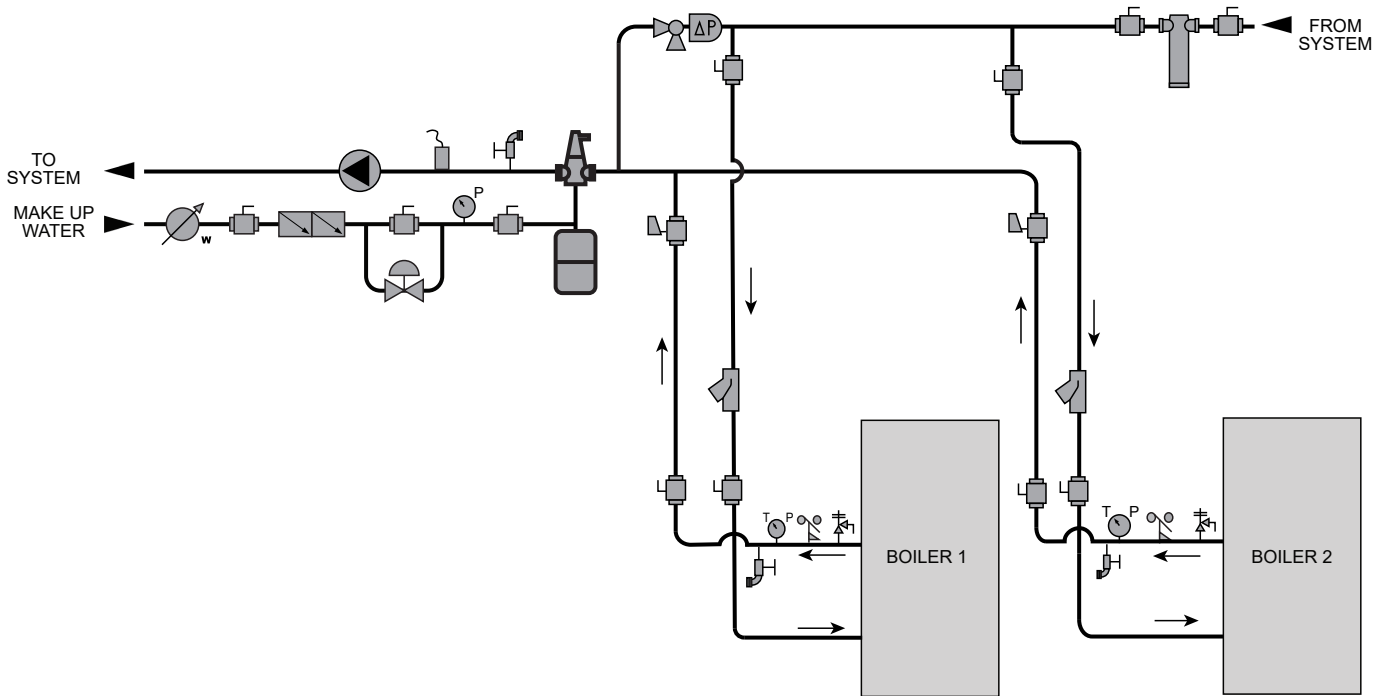

AIR SEPARATOR	DIFFERENTIAL PRESSURE BYPASS VALVE	FLOW SWITCH OPTIONAL	PRESSURE RELIEF VALVE	TEMPERATURE & PRESSURE GAUGE
BACKFLOW PREVENTER	DRAIN PORT	MAGNETIC SEPARATOR	PRESSURE GAUGE	WATER METER
BALL VALVE	EXPANSION TANK	MIXING VALVE ANTI SCALD	SYSTEM SUPPLY SENSOR	2 WAY MOTORIZED VALVE (OPTIONAL)
CIRCULATION PUMP	FLOW CHECK VALVE	PRESSURE REDUCING VALVE	STRAINER / FILTER	PIPING ----- WIRING

2000809751 01

CAUTION

Mixing valves are required for the protection of low temperature loops.

NOTICE

Please note that these illustrations are meant to show system piping concept only, the installer is responsible for all equipment and detailing required by local codes. Connection locations shown are for reference only and will vary with boiler type.

3 Hydronic piping (continued)

Figure 3-5 Single Boiler - Multiple Temperatures

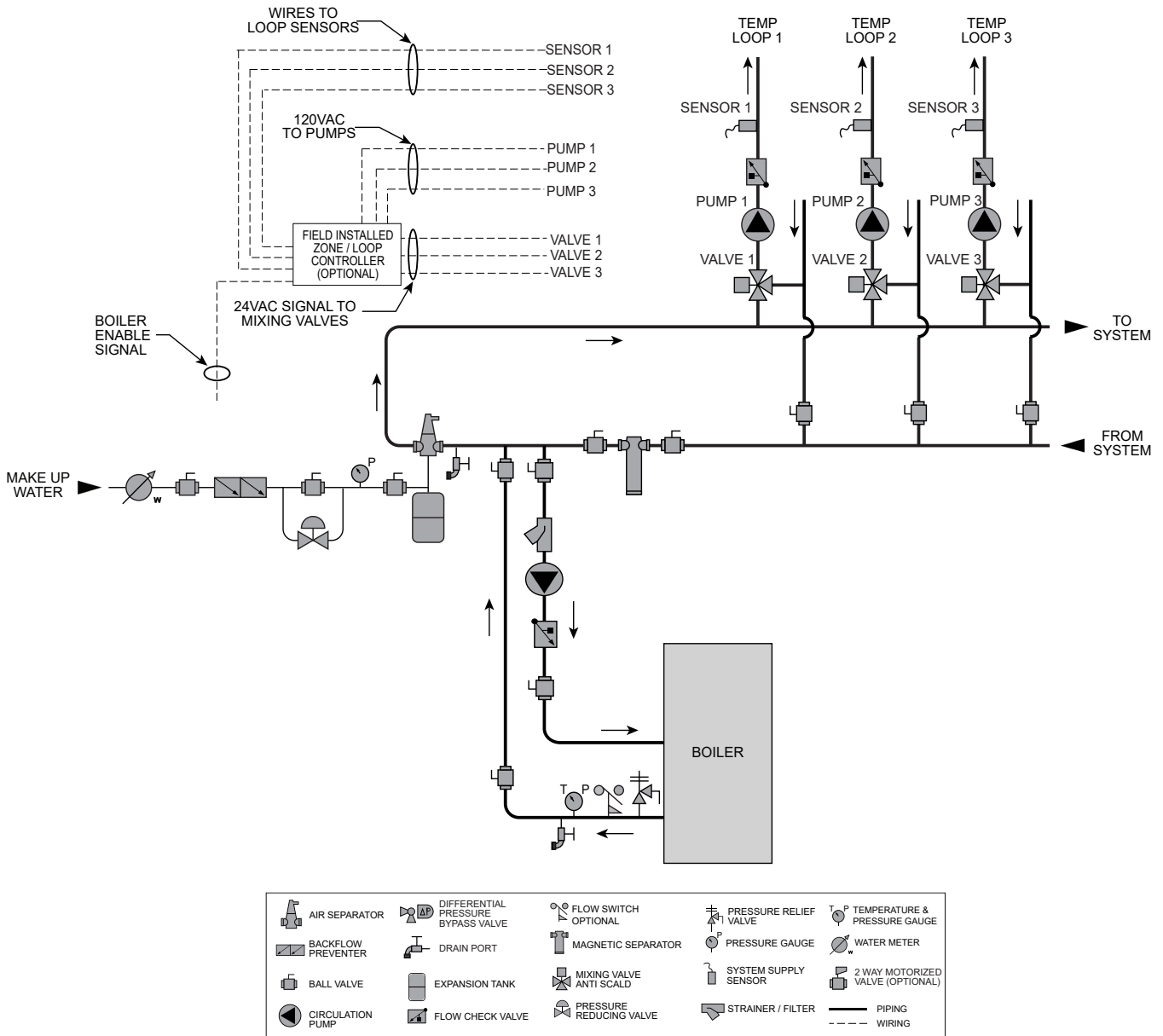

2000809762 01

CAUTION

Mixing valves are required for the protection of low temperature loops.

NOTICE

Please note that these illustrations are meant to show system piping concept only, the installer is responsible for all equipment and detailing required by local codes. Connection locations shown are for reference only and will vary with boiler type.

3 Hydronic piping

Figure 3-6 Single Boiler - Primary/Secondary Piping

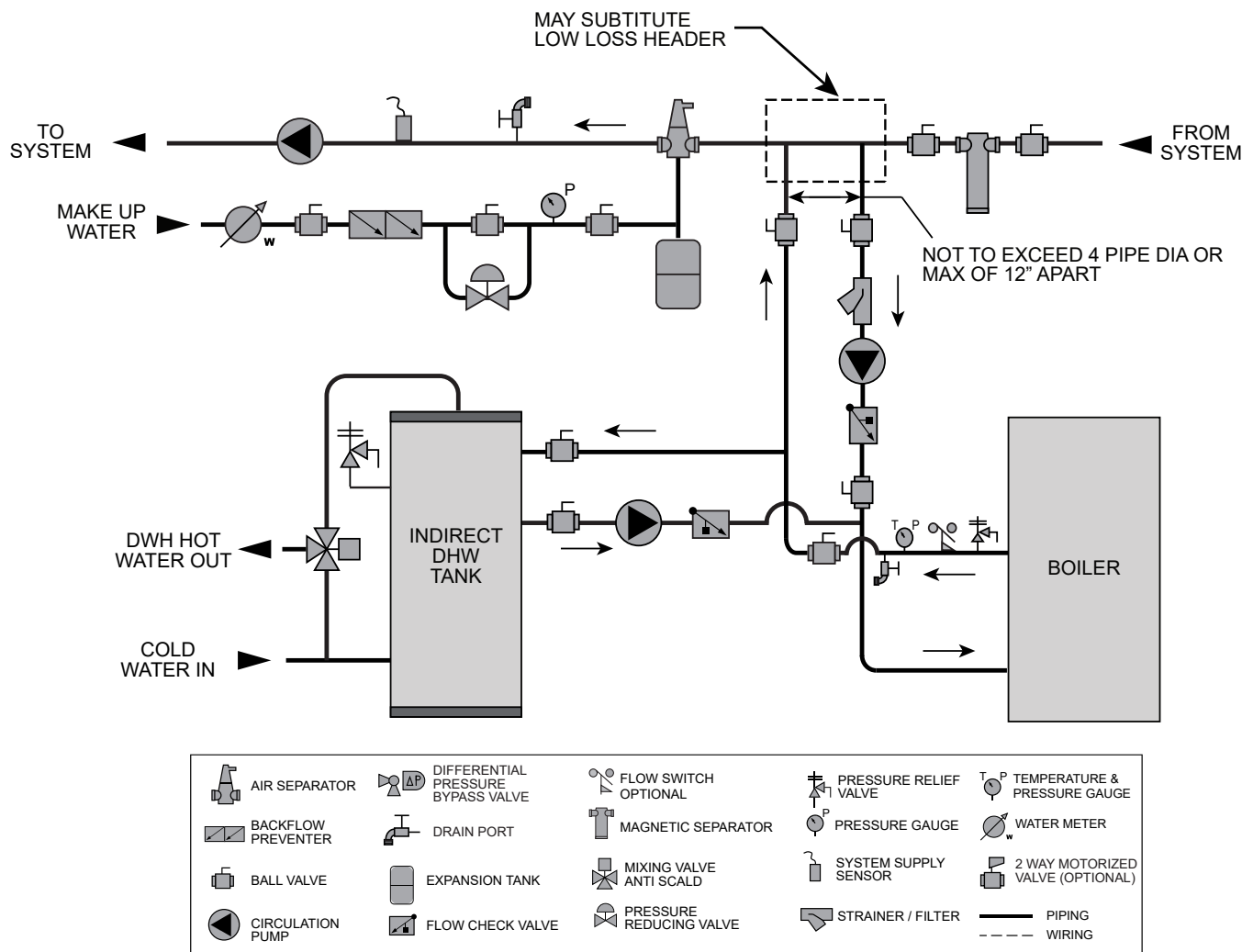

2000809763 00

CAUTION

Indirect water heaters are capable of transferring a limited number of Btu's into the water. Ensure boiler output does not exceed indirect boiler transfer capabilities.

NOTICE

Please note that these illustrations are meant to show system piping concept only, the installer is responsible for all equipment and detailing required by local codes. Connection locations shown are for reference only and will vary with boiler type.

NOTICE

System flow should always remain higher than the required flow for the boiler(s) when the boiler(s) is in operation to prevent short cycling and high limit issues.

3 Hydronic piping (continued)

Figure 3-7 Multiple Boilers - Multiple Temperatures

Model	Number of Units						
	2	3	4	5	6	7	8
Manifold Pipe Sizes in Inches (mm)							
0015 to 0150	3 1/2 (89)	4 (102)	5 (127)	6 (152)	6 (152)	8 (203)	8 (203)

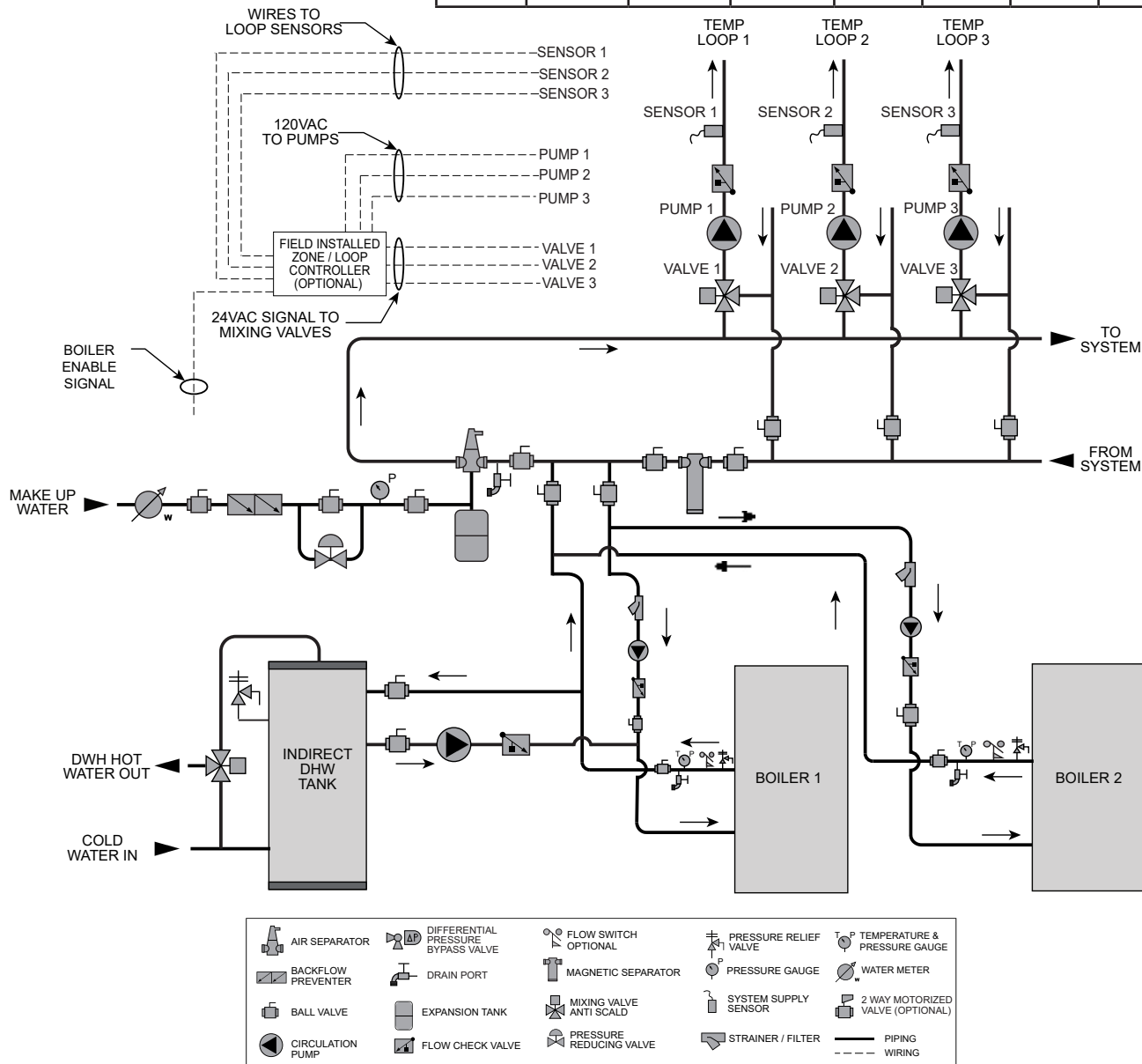

2000809764 00

CAUTION Indirect water heaters are capable of transferring a limited number of Btu's into the water. Ensure boiler output does not exceed indirect boiler transfer capabilities.

CAUTION Mixing valves are required for the protection of low temperature loops.

NOTICE Please note that these illustrations are meant to show system piping concept only, the installer is responsible for all equipment and detailing required by local codes. Connection locations shown are for reference only and will vary with boiler type.

3 Hydronic piping

Figure 3-8 Multiple Boilers - Primary/Secondary Piping

Model	Number of Units						
	2	3	4	5	6	7	8
Manifold Pipe Sizes in Inches (mm)							
0015 to 0150	3 1/2 (89)	4 (102)	5 (127)	6 (152)	6 (152)	8 (203)	8 (203)

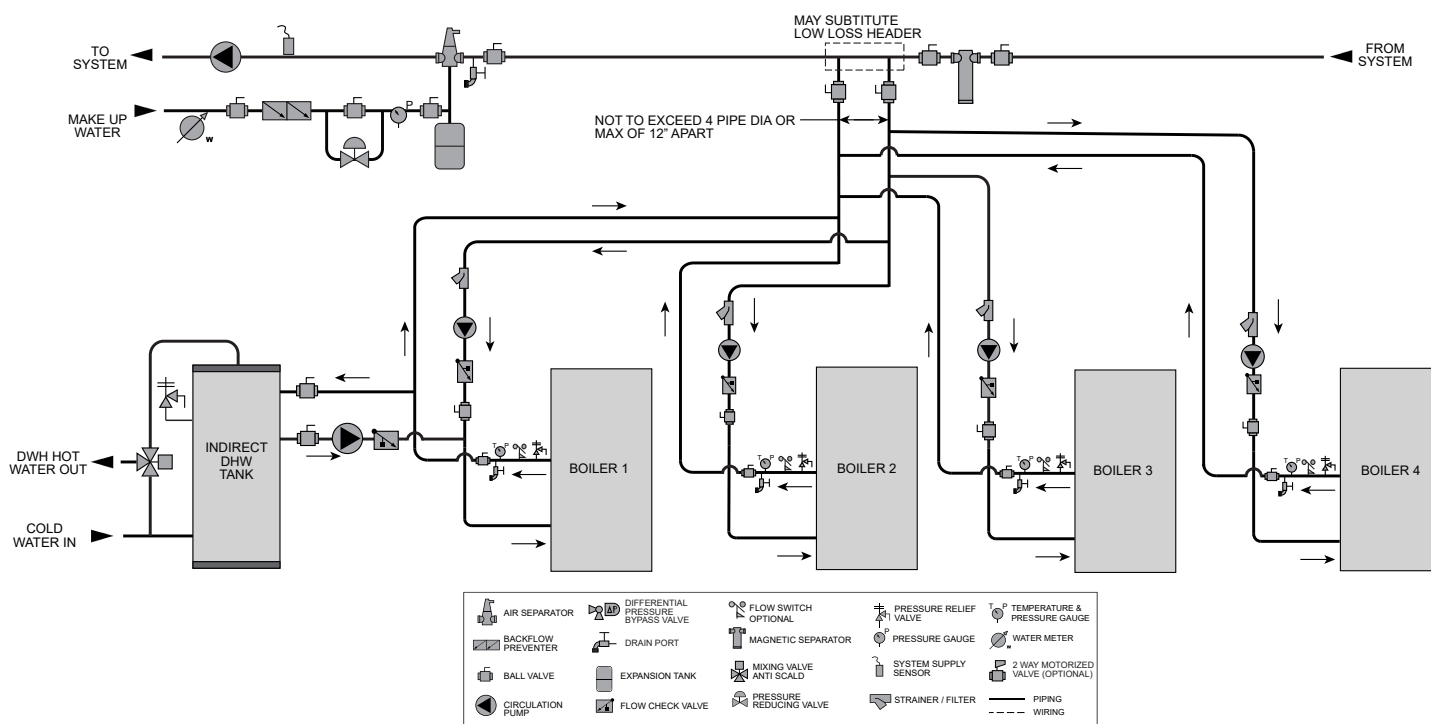

CAUTION Indirect water heaters are capable of transferring a limited number of Btu's into the water. Ensure boiler output does not exceed indirect boiler transfer capabilities.

NOTICE Please note that these illustrations are meant to show system piping concept only, the installer is responsible for all equipment and detailing required by local codes. Connection locations shown are for reference only and will vary with boiler type.

NOTICE System flow should always remain higher than the required flow for the boiler(s) when the boiler(s) is in operation to prevent short cycling and high limit issues.

3 Hydronic piping (continued)

Figure 3-9 Single Boiler - Multiple Temperatures with DHW Piped as a Zone

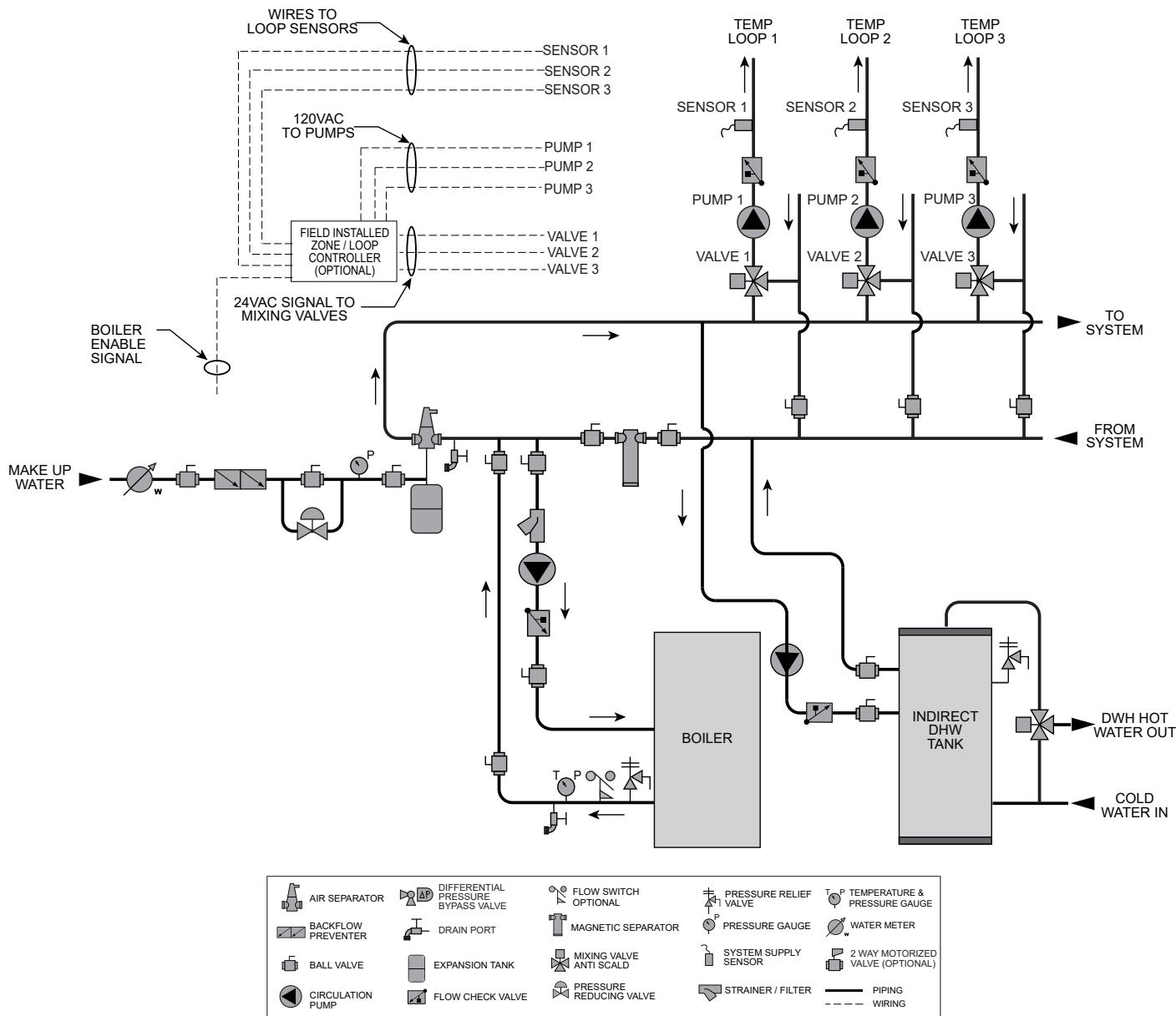

2000809766 01

CAUTION

Indirect water heaters are capable of transferring a limited number of Btu's into the water. Ensure boiler output does not exceed indirect boiler transfer capabilities.

CAUTION

Mixing valves are required for the protection of low temperature loops.

NOTICE

Please note that these illustrations are meant to show system piping concept only, the installer is responsible for all equipment and detailing required by local codes. Connection locations shown are for reference only and will vary with boiler type.

NOTICE

Please note that the installer is responsible for ensuring DHW prioritization when piped as a zone.

4 Field wiring

⚠ WARNING

ELECTRICAL SHOCK HAZARD – For your safety, turn off electrical power supply before making any electrical connections to avoid possible electric shock hazard. Failure to do so can cause severe personal injury or death.

NOTICE

Wiring must be N.E.C. Class 1. If original wiring as supplied with boiler must be replaced, use only type 105°C wire or equivalent.

Boiler must be electrically grounded as required by National Electrical Code ANSI/NFPA 70 – latest edition.

⚠ CAUTION

Label all wires prior to disconnection when servicing controls. Wiring errors can cause improper and dangerous operation.

Line voltage connections

1. Connect the power wiring to the line voltage distribution block in the back of the unit.
2. Provide and install a fused disconnect or service switch as required by the code (see Table 4C).
3. When connecting a domestic hot water (DHW) pump, connect the wiring to a 120 VAC power wiring as shown in FIG. 4-3.
4. To activate a boiler or system pump, wire as shown in FIG. 4-3. Dry contacts are sized for 1.5 hp/120V, 3 hp/240V or 30 amps.

Low voltage connections

1. Route all low voltage wires through the knockouts in the rear of the boiler, as shown in FIG. 4-2.
2. Connect low voltage wiring to the low voltage connection board as shown in FIG. 4-3 on page 27 of this manual and the boiler wiring diagram.

Figure 4-1 Line Voltage Field Wiring Connections

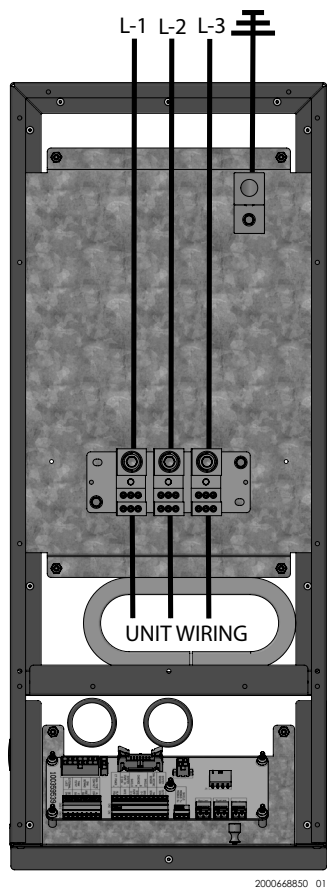
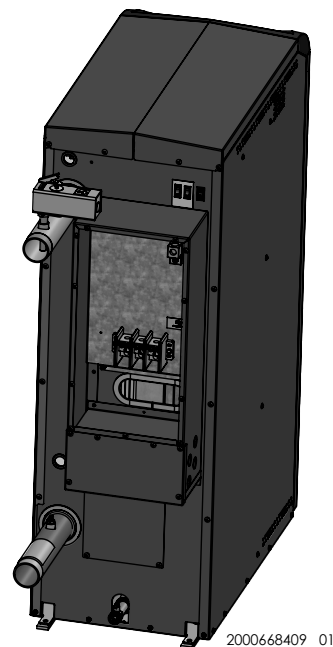

Figure 4-2 Routing Field Wiring



Installation must comply with:

1. National Electrical Code and any other national, state, provincial, or local codes, or regulations.
2. In Canada, CSA C22.1 Canadian Electrical Code Part 1, and any local codes.

Thermostat

1. Connect the room thermostats or end switches (isolated contact only) to heat/loop demand as shown in FIG. 4-3.
2. Install the thermostat on the inside wall away from influences of drafts, hot or cold-water pipes, lighting fixtures, television, sunlight, or fireplaces.
3. Thermostat anticipator (if applicable):
 - a. If connected directly to boiler, set for 0.1 amps.
 - b. If connected to relays or other devices, set to match total electrical power requirements of connected devices. See device manufacturers' specifications and thermostat instructions for details.

4 Field wiring *(continued)*

Outdoor temperature sensor

1. Mount the sensor on an exterior wall, shielded from direct sunlight or flow of heat or cooling from other sources.
2. Route sensor wires through a knockout at the rear of the boiler (see FIG. 4-2).
3. Connect the outdoor temperature sensor (FIG. 4-3) to the outdoor sensor terminals on the connection board to enable outdoor reset operation of the Lectrus. If fixed temperature operation is required, do not install outdoor sensor.

DHW (Domestic Hot Water) thermostat

Connect the indirect water heater (DHW) thermostat (FIG. 4-3) to the DHW thermostat terminals on the connection board. If a tank sensor is connected (see DHW Tank Sensor below) the tank thermostat is ignored.

DHW tank sensor

By installing a tank sensor, the SMART SYSTEM control can perform the tank thermostat function. The SMART SYSTEM control automatically detects the presence of this sensor and generates a DHW call for heat when the tank temperature drops 6°F (3°C) below the tank set point and finishes the call for heat when the tank temperature reaches the tank set point.

The tank sensor included with the Lochinvar Squire® indirect DHW tanks (100170544) is the only sensor suitable for use with the SMART SYSTEM control. Connect the sensor leads to the Tank Sensor terminals on the low voltage connection board (FIG. 4-3).



WARNING Failure to use the correct sensor may result in the tank temperature being either above or below the set point.

If 100170544 is not compatible with the indirect tank, a tank thermostat can be used to control the boiler. The tank thermostat should be installed per the manufacturer's instructions and wired to the DHW Thermostat terminals on the low voltage connection board (FIG. 4-3).

Variable speed system pump

If a variable speed pump is used in the primary loop, and a 0-10V signal is available from the pump speed control, this signal can be used by the SMART SYSTEM control to anticipate changes in the building heat load. By connecting this 0 - 10V signal to the 0 - 10V SYS PUMP IN terminals, the boiler (or cascade) can modulate up and down as the primary flow increases and decreases.

Boiler pump speed output

This 0 - 10V output is available to control the speed of a variable speed boiler pump. The SMART SYSTEM control will vary the speed of this pump to maintain a minimum ΔT across the pressure vessel, as well as prevent high limit lockouts when the flow in the primary loop is extremely low. NOTE: This feature is to be used with Primary / Secondary piping systems only. A system supply sensor MUST be installed. Connect this output to the 0 - 10V input on the boiler pump speed control.

Rate output

This output provides a 0 - 10V signal that is proportional to the element power of the boiler. This may be used by a BMS system to monitor the actual rate of the boiler.

ModBus/BACnet

When an optional ModBus or BACnet interface module is installed, the RS-485 cable is connected to these terminals. Use shielded, 2-wire twisted pair cable. If desired, the shield can be connected to ground by installing a jumper wire between terminals 1 and 3 on connector X5 on the optional ModBus or BACnet interface module.

Flow switch (optional)

1. A flow switch is used to guarantee flow through the boiler before allowing it to fire. The flow switch must be installed at the boiler outlet.
2. Remove the jumper wire from the terminals on the connection board and connect these terminals to the normally open contacts on the flow switch (FIG. 4-3).

System supply sensor

1. By installing the system supply sensor into the supply of the primary loop, the temperature of the system supply can be controlled. The SMART SYSTEM control automatically detects the presence of this sensor and controls the boiler element power to maintain the system supply temperature to the set point (if outlet sensor control is currently selected).

See the Lectrus Service Manual for instructions on how to use the inlet sensor as the controlling sensor. When the inlet sensor is programmed as the controlling sensor, it is vital that the SYSTEM SUPPLY sensor be installed. DO NOT INSTALL THE SYSTEM SUPPLY SENSOR INTO THE SYSTEM RETURN.

2. The 100170581 sensor provided with the boiler must be used for the system sensor.
3. Connect these terminals to the system supply sensor (FIG. 4-3).

4 Field wiring

Alarm Bell (optional)

When there is a lock out, the alarm bell contact on the connection board is activated. When a bell is plugged in a loud sound will alert the operator of an issue with the boiler.

Boiler management system

1. An external control may be connected to control either the element power or the set point of the boiler. If the external control uses a set of contacts to enable the boiler, connect the contacts to the heat/loop demand 1 terminals. Otherwise, the SMART SYSTEM control will be enabled by the 0-10V signal.
2. Make sure the (-) terminal is connected to the (-) or common output terminal of the external control, and the (+) terminal is connected to the 0 - 10 VDC or (+) terminal of the external control. Make sure that the (-) voltage is not below ground.

Runtime contacts

The SMART SYSTEM control closes a set of dry contacts whenever the heating elements is energized. This is typically used by Building Management Systems to verify that the boiler is responding to a call for heat.

Alarm contacts

The SMART SYSTEM control closes another set of contacts whenever the boiler is locked out or the power is turned off. This can be used to turn on an alarm or signal a Building Management System that the boiler is down.

Wiring of the cascade

When wiring the boilers for Cascade operation, select one boiler as the Leader boiler. The remaining boilers will be designated as Members. See page 45 “Configuration of the Cascade” for a detailed explanation of this procedure.

Connect the system supply sensor and outdoor air sensor (if used) to the Leader boiler. For the Cascade system to work properly the system supply sensor must be installed. The location of the system supply sensor should be downstream of the boiler connections in the main system loop (FIG.'s 3-4 through 3-9). The system supply sensor should be wired to the Connection Board at the terminals marked for the system sensor (see FIG. 4-3). The Leader control will use the water temperature at the system supply sensor to control the operation of the Cascade.

If outdoor air reset is desired, the outdoor air sensor should be wired to the Connection Board at the terminals marked for the outdoor sensor (FIG. 4-3). If the outdoor air sensor is connected, the Leader control will calculate the water temperature set point based on the programmed reset curve parameters. If the outdoor air sensor is not connected, the Leader control will maintain the fixed water temperature set point that is programmed into the control.

If a Thermostat or Zone Control enable output is available, it should be wired to the Connection Board on the Leader boiler at the terminals marked for the heat/loop demand. (FIG. 4-3).

4 Field wiring (continued)

Communication between the Leader boiler and the Member boilers is accomplished by using shielded, 2-wire twisted pair communication cable. Connect one of the twisted pair wires to Cascade terminal A on each of the Connection boards, and the other wire of the twisted pair to Cascade terminal B on each of the Connection Boards. Connect the shield wires to one of the shield terminals on the Connection Boards (FIG. 4-3). If more than two boilers are on the Cascade, daisy chain the wiring from the Cascade terminals on the second boiler to the Cascade terminals on the third boiler, then from the third to the fourth, and so on. The connections between boilers can be made in any order, regardless of the addresses of the boilers. Try to keep each cable as short as possible.

When the Member 1 boiler is programmed as an alternate leader this allows the Member 1 boiler to automatically assume control of the Cascade should it lose communication with the Leader boiler. When programmed to YES, it is recommended that the Member 1 boiler have its own set of external sensors installed (such as the system supply sensor), to maintain the same level of temperature control as with the Leader boiler. Voltage signals (such as 0 - 10V system pump speed input) can be connected to both boilers.

WARNING Do not connect the sensors connected to the Leader boiler to the Member 1 boiler. The actual water temperatures will be higher than expected, which could lead to property damage, personal injury, or death.

When communication is re-established with the Leader boiler, Member 1 will automatically relinquish control of the Cascade to the Leader boiler.

Figure 4-3 Field Wiring Connections

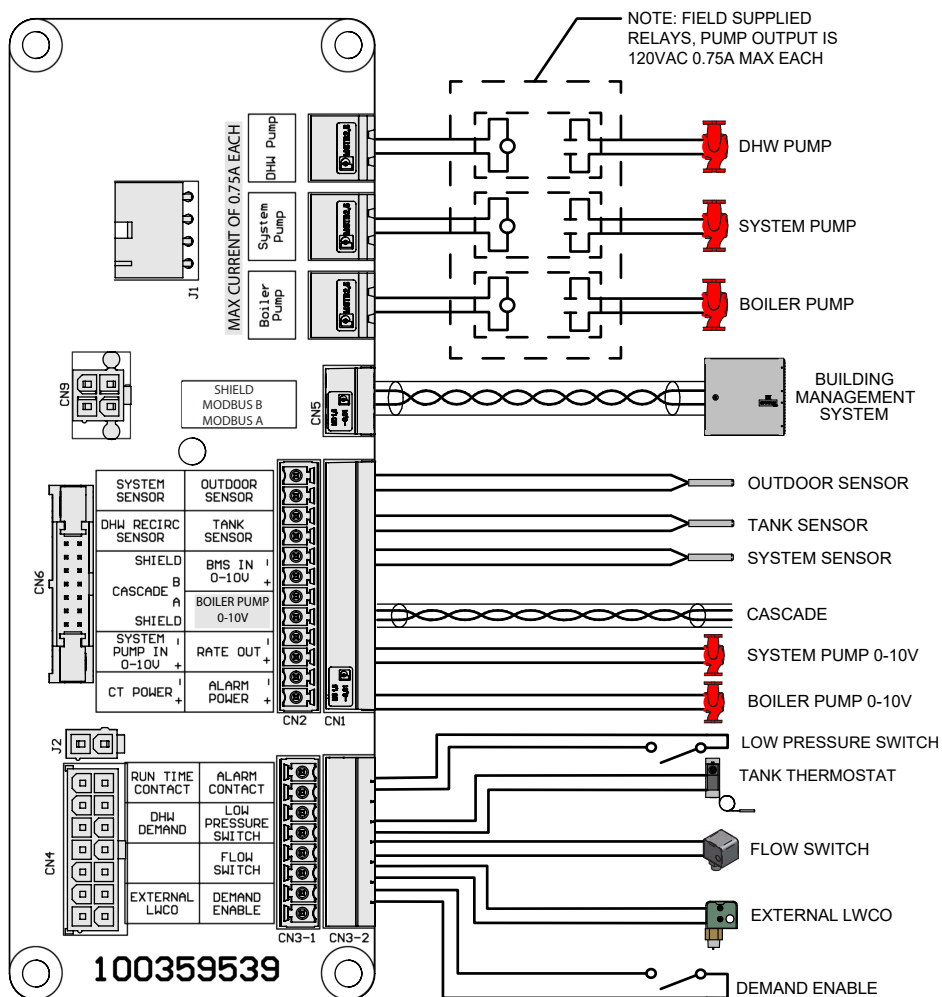

2000668839_000 REV D

4 Field wiring

Branch Circuit

The branch circuit wire size should be established through reference to the NEC (National Electrical Code) or other locally approved sources in conjunction with the boiler amperage rating. Wire rated at 167°F (75°C) should be used. Please see Table 4B for additional information. It is suggested that the electrician size the branch circuit at 125% of the boiler rating and further increase wire size as necessary to compensate for voltage drop in long runs. Voltage drop should not exceed 3% at the boiler.

Power Circuit

Power circuit wiring is type THHN (or equivalent) rated 600 volts, 221°F (105°C) sized as necessary.

The wiring diagrams at the end of this manual are included to show typical arrangements of electrical components in the control and power circuits by voltage and phase characteristics. They are to be used as a reference by the installer or servicer in performing their work. An actual diagram of the boiler wiring is furnished with the boiler.

Electrical Connections

Power Feed Wiring

The recommended wire size is listed on both the unit's Bill of Material (BOM) and the Wiring Diagram (WD). Also, the full load amperage and maximum voltage are stamped on the unit's nameplate. The feeder must be sized for 125% of the full load amperage in accordance with Article 424-3 of the NEC. The wiring must have insulation rated 167°F (75°C) or greater. Copper wiring is recommended for all power connections. The recommended size is noted in the 'Notes' on the wiring diagram.

CAUTION Do not exceed the maximum voltage as listed on the nameplate. For resistance loads, amperage increases proportionally with voltage.

Equipment Grounding Conductors

The unit is equipped with grounding lug(s) inside the power panel(s). The grounding conductors must be installed and sized in accordance with NEC Article 424-14. The recommended size is noted in the 'Notes' on the diagram.

NOTICE All power connections are 3-Phase, 3-Wire. (Exception: If unit is single phase.) There is no provision for a neutral connection; (IE: the unit should not be wired 'wye' or 'star').

4 Field wiring *(continued)*

Table 4A Amp Chart

MODEL	KW	BTU/HR	"FULL LOAD AMPS (FLA)"	ELEMENT(S)	MODULATION BANK	RELAY(S) BANK	MAXIMUM OVERCURRENT CIRCUIT PROTECTION (MOCP)	MINIMUM CIRCUIT AMPACITY (MCA)	DISTRIBUTION BLOCK LINE SIDE MAXIMUM WIRE SIZE
240 VAC - 60 Hz - SINGLE PHASE (L1-L2) 2 conductors Cu or Al with a ground									
0015	15	51,182	65.8	1 x 15 kW	1 x 15 kW	-	90	83	1 x 350 MCM
0030	30	102,364	131.6	2 x 15 kW	1 x 15 kW	1 x 15 kW	175	165	
208 VAC - 60 Hz - THREE PHASE (L1-L2-L3) 3 conductors Cu or Al with a ground									
0015	15	51,182	43.8	1 x 15 kW	1 x 15 kW	-	60	55	1 x 2/0 AWG
0030	30	102,364	87.7	2 x 15 kW	1 x 15 kW	1 x 15 kW	110	110	
0045	45	153,546	131.5	3 x 15 kW	1 x 15 kW	2 x 15 kW	175	165	
0060	60	204,728	175.3	4 x 15 kW	1 x 15 kW	3 x 15 kW	225	220	1 x 350 MCM
0075	75	255,911	219.1	5 x 15 kW	1 x 15 kW	4 x 15 kW	300	274	
0090	90	307,093	263.0	6 x 15 kW	1 x 30 kW	2 x 30 kW	350	329	1 x 500 MCM
0105	105	358,275	306.8	7 x 15 kW	1 x 30 kW	2 x 30 kW - 1 x 15 kW	400	384	2 x 300 MCM
0120	120	409,457	350.6	8 x 15 kW	1 x 30 kW	3 x 30 kW	450	439	
0135	135	460,639	394.5	9 x 15 kW	1 x 30 kW	3 x 30 kW - 1 x 15 kW	500	494	
0150	150	511,821	438.3	10 x 15 kW	1 x 30 kW	4 x 30 kW	600	548	
480 VAC - 60 Hz - THREE PHASE (L1-L2-L3) 3 conductors Cu or Al with a ground									
0015	15	51,182	19.0	1 x 15 kW	1 x 15 kW	-	25	24	1 x 2/0 AWG
0030	30	102,364	38.0	2 x 15 kW	1 x 15 kW	1 x 15 kW	50	48	
0045	45	153,546	57.0	3 x 15 kW	1 x 15 kW	2 x 15 kW	80	72	
0060	60	204,728	76.0	4 x 15 kW	1 x 15 kW	3 x 15 kW	100	95	
0075	75	255,911	95.0	5 x 15 kW	1 x 15 kW	4 x 15 kW	125	119	
0090	90	307,093	114.0	6 x 15 kW	1 x 30 kW	2 x 30 kW	150	143	1 x 350 MCM
0105	105	358,275	132.9	7 x 15 kW	1 x 30 kW	2 x 30 kW - 1 x 15 kW	175	167	
0120	120	409,457	151.9	8 x 15 kW	1 x 30 kW	3 x 30 kW	200	190	
0135	135	460,639	170.9	9 x 15 kW	1 x 30 kW	3 x 30 kW - 1 x 15 kW	225	214	
0150	150	511,821	189.9	10 x 15 kW	1 x 30 kW	4 x 30 kW	250	238	

4 Field wiring

Table 4A Amp Chart (continued)

MODEL	KW	BTU/HR	"FULL LOAD AMPS (FLA)"	ELEMENT(S)	MODULATION BANK	RELAY(S) BANK	MAXIMUM OVERCURRENT CIRCUIT PROTECTION (MOCP)	MINIMUM CIRCUIT AMPACITY (MCA)	DISTRIBUTION BLOCK LINE SIDE MAXIMUM WIRE SIZE
600 VAC - 60 Hz - THREE PHASE (L1-L2-L3) 3 conductors Cu or Al with a ground									
0015	15	51,182	14.4	1 x 15 kW	1 x 15 kW	-	20	19	1 x 2/0 AWG
0030	30	102,364	28.9	2 x 15 kW	1 x 15 kW	1 x 15 kW	40	38	
0045	45	153,546	43.3	3 x 15 kW	1 x 15 kW	2 x 15 kW	60	57	
0060	60	204,728	57.7	4 x 15 kW	1 x 15 kW	3 x 15 kW	80	76	
0075	75	255,911	72.2	5 x 15 kW	1 x 15 kW	4 x 15 kW	100	95	
0090	90	307,093	86.6	6 x 15 kW	1 x 30 kW	2 x 30 kW	110	114	
0105	105	358,275	101.0	7 x 15 kW	1 x 30 kW	2 x 30 kW - 1 x 15 kW	150	133	1 x 350 MCM
0120	120	409,457	115.5	8 x 15 kW	1 x 30 kW	3 x 30 kW	150	152	
0135	135	460,639	129.9	9 x 15 kW	1 x 30 kW	3 x 30 kW - 1 x 15 kW	175	171	
0150	150	511,821	144.3	10 x 15 kW	1 x 30 kW	4 x 30 kW	200	190	

4 Field wiring *(continued)*

Table 4B Electrical Recoveries Data

MODEL	KW	Elements Size (KW)	Number of Element(s)	Number of Contractors	Number of Bank(s)	Number of Element(s) Per Bank(s)	Number of Control Boards	Number of Modulation Boards	Number of Triac Boards / Fans
240 VAC - 60 Hz - SINGLE PHASE									
0015	15	15	1	2	1	1	1	1	1
0030	30	15	2	4	2	1	1	1	1
208 VAC - 60 Hz - THREE PHASE									
0015	15	15	1	1	1	1	1	1	1
0030	30	15	2	2	2	1	1	1	1
0045	45	15	3	3	3	1	1	1	1
0060	60	15	4	4	4	1	1	1	1
0075	75	15	5	5	5	1	1	1	1
0090	90	15	6	6	3	2	1	1	2
0105	105	15	7	7	4	2 / 1	1	1	2
0120	120	15	8	8	4	2	1	1	2
0135	135	15	9	9	5	2 / 1	1	1	2
0150	150	15	10	10	5	2	1	1	2
480 VAC - 60 Hz - THREE PHASE									
0015	15	15	1	1	1	1	1	1	1
0030	30	15	2	2	2	1	1	1	1
0045	45	15	3	3	3	1	1	1	1
0060	60	15	4	4	4	1	1	1	1
0075	75	15	5	5	5	1	1	1	1
0090	90	15	6	3	3	2	1	1	2
0105	105	15	7	4	4	2 / 1	1	1	2
0120	120	15	8	4	4	2	1	1	2
0135	135	15	9	5	5	2 / 1	1	1	2
0150	150	15	10	5	5	2	1	1	2
600 VAC - 60 Hz - THREE PHASE									
0015	15	15	1	1	1	1	1	1	1
0030	30	15	2	2	2	1	1	1	1
0045	45	15	3	3	3	1	1	1	1
0060	60	15	4	4	4	1	1	1	1
0075	75	15	5	5	5	1	1	1	1
0090	90	15	6	3	3	2	1	1	2
0105	105	15	7	4	4	2 / 1	1	1	2
0120	120	15	8	4	4	2	1	1	2
0135	135	15	9	5	5	2 / 1	1	1	2
0150	150	15	10	5	5	2	1	1	2

4 Field wiring

Table 4C Fuses

Model	Elements Fuse (Amps)	Elements Fuse Voltage - Class	Elements Fuse Quantity	Transformer Fuse (Amps)	Transformer Fuse Voltage - Class	Transformer Fuse Quantity	Control Fuse (Amps)	Controls Fuse Voltage - Class	Controls Fuse Quantity
240 VAC - 60 Hz - SINGLE PHASE									
0015	30	300 VAC - T	6	15	300 VAC - T	2	15	250 VAC - K5	1
0030	30	300 VAC - T	12	15	300 VAC - T	2	15	250 VAC - K5	1
208 VAC - 60 Hz - THREE PHASE									
0015	60	300 VAC - T	3	15	300 VAC - T	2	15	250 VAC - K5	1
0030	60	300 VAC - T	6	15	300 VAC - T	2	15	250 VAC - K5	1
0045	60	300 VAC - T	9	15	300 VAC - T	2	15	250 VAC - K5	1
0060	60	300 VAC - T	12	15	300 VAC - T	2	15	250 VAC - K5	1
0075	60	300 VAC - T	15	15	300 VAC - T	2	15	250 VAC - K5	1
0090	60	300 VAC - T	18	15	300 VAC - T	2	15	250 VAC - K5	1
0105	60	300 VAC - T	21	15	300 VAC - T	2	15	250 VAC - K5	1
0120	60	300 VAC - T	24	15	300 VAC - T	2	15	250 VAC - K5	1
0135	60	300 VAC - T	27	15	300 VAC - T	2	15	250 VAC - K5	1
0150	60	300 VAC - T	30	15	300 VAC - T	2	15	250 VAC - K5	1
480 VAC - 60 Hz - THREE PHASE									
0015	30	600 VAC - T	3	15	600 VAC - T	2	15	250 VAC - K5	1
0030	30	600 VAC - T	6	15	600 VAC - T	2	15	250 VAC - K5	1
0045	30	600 VAC - T	9	15	600 VAC - T	2	15	250 VAC - K5	1
0060	30	600 VAC - T	12	15	600 VAC - T	2	15	250 VAC - K5	1
0075	30	600 VAC - T	15	15	600 VAC - T	2	15	250 VAC - K5	1
0090	60	600 VAC - T	9	15	600 VAC - T	2	15	250 VAC - K5	1
0105	60	600 VAC - T	12	15	600 VAC - T	2	15	250 VAC - K5	1
0120	60	600 VAC - T	12	15	600 VAC - T	2	15	250 VAC - K5	1
0135	60	600 VAC - T	15	15	600 VAC - T	2	15	250 VAC - K5	1
0150	60	600 VAC - T	15	15	600 VAC - T	2	15	250 VAC - K5	1
600 VAC - 60 Hz - THREE PHASE									
0015	25	600 VAC - T	3	15	600 VAC - T	2	15	250 VAC - K5	1
0030	25	600 VAC - T	6	15	600 VAC - T	2	15	250 VAC - K5	1
0045	25	600 VAC - T	9	15	600 VAC - T	2	15	250 VAC - K5	1
0060	25	600 VAC - T	12	15	600 VAC - T	2	15	250 VAC - K5	1
0075	25	600 VAC - T	15	15	600 VAC - T	2	15	250 VAC - K5	1
0090	50	600 VAC - T	9	15	600 VAC - T	2	15	250 VAC - K5	1
0105	50	600 VAC - T	12	15	600 VAC - T	2	15	250 VAC - K5	1
0120	50	600 VAC - T	12	15	600 VAC - T	2	15	250 VAC - K5	1
0135	50	600 VAC - T	15	15	600 VAC - T	2	15	250 VAC - K5	1
0150	50	600 VAC - T	15	15	600 VAC - T	2	15	250 VAC - K5	1

5 Start-up

Pre-Commissioning Cleaning

CAUTION

Do not use petroleum-based cleaning or sealing compounds in the boiler system. Gaskets and seals in the system may be damaged. This can result in substantial property damage.

1. Prior to fill and start-up, isolate the boiler from the system and flush the entire heating system.
2. Clean the entire heating system with an approved pre-commissioning cleaner (comparable to Sentinel X300 and Fernox F3) in accordance with the manufacturer's recommendation to remove debris and prolong the life of the pressure vessel.
3. Clean all water filtering devices in the system.
4. Flush the cleaning solution out of the entire system and refill.

Check/control fill water chemistry

IMPORTANT

Conduct water quality testing prior to installing the appliance. Various solutions are available to adjust water quality.

CAUTION

DO NOT use "homemade cures" or "boiler patent medicines". Serious damage to boiler, personnel, and/or property may result.

The manufacturer recommends the following for properly filling your boiler with the appropriate water chemistry for closed loop boilers. Good boiler water quality will help extend the life of the appliance by reducing the effects of lime scale build-up and corrosion in closed loop systems.

Boiler Water / Make-Up Water Hardness and System Volume

Table 5A provides guidelines for the maximum allowable hardness levels for both the boiler water and the make-up water based on the system volume. There are two (2) levels of allowable hardness depending on the size of the system. These levels are to be chosen based on the smallest boiler size in the system.

Table 5A Boiler Water and Make-Up Water Total Hardness Specifications

	Level I	Level II
System Volume	≤ 1,000 gal	> 1,000 gal
Total Hardness	≤ 12 gpg	≤ 9 gpg

1. Initial system fill must meet the recommended values of hardness for boiler water / make-up water. This may require water treatment such as using demineralizers.
2. During the life of the boiler system, the sum of the total system fill and make-up water quantities should not exceed three (3) times the system volume.

3. Consult local water treatment companies for hard water areas (above the values listed in Table 5A). Hardness levels that are above the values listed in Table 5A can lead to lime scale build-up throughout the boiler system.

Additional Boiler Water and Make-Up Water Specifications

Table 5B Additional Boiler Water and Make-Up Water Specifications

	Boiler Water	Make-Up Water
Total Dissolved Solids	≤ 1,000 ppm	< 350 ppm
pH Level	6.5 - 9.5	
Chlorides	< 150 ppm	

Chloride Concentration

1. Do not fill boiler or operate with water containing chlorine more than 150 ppm.
2. Do not use the boiler to directly heat swimming pool or spa water.

Iron Concentration

1. Do not fill boiler or operate with water containing iron more than 0.3 ppm.

Total Dissolved Solids (TDS)

1. Total dissolved solids are all minerals, salts, metals, and charged particles that are dissolved in water.
2. The greater the amounts of TDS present, the higher the corrosion potential due to increased conductivity in the water. Refer to Table 5B for more information.

Additional Considerations

1. Monitoring pH, chlorides, TDS, and hardness levels can prolong the life of the appliance by reducing lime scale build-up, corrosion, and erosion. Check for leaks to ensure that fresh water is not entering the system.
2. Continual fresh make-up water will reduce boiler life.
3. Mineral build-up in the pressure vessel reduces heat transfer, overheats the stainless-steel pressure vessel, and causes failure.
4. The addition of oxygen carried in by make-up water can cause internal corrosion in the system components.
5. Leaks in the boiler or piping must be repaired at once to prevent excessive make-up water. For this purpose, it is recommended to install a water meter to easily check the amount of make-up water entering the system. Make-up water volume should not exceed 5% of the total system volume per year. **NOTE:** When make-up water is added, make sure the chemical additives are added to maintain the correct level.

5 Start-up

- An approved multi-metal corrosion inhibitor (comparable to Sentinel X100 or Fernox F1) is recommended at the correct concentration and in the manner recommended by the manufacturer.

Freeze protection fluids

WARNING Ethylene glycol is toxic. DO NOT use as your freeze protection fluid. Ethylene glycol has a sweet aroma which children and pets could mistake as food and ingest, leading to death.

- Use glycol only if needed for freeze protection fluid.
- Propylene glycol is the recommended freeze protection fluid.
- Make sure to flush the boiler system before adding glycol.
- Determine the freeze protection fluid quantity using system water content, following the fluid manufacturer's instructions. Boiler water content is listed in the Boiler Specifications Table on page 6. Remember to include expansion tank water content.
- Local codes may require a backflow preventer or actual disconnect from city water supply.
- When using freeze protection fluid with automatic fill, it is suggested to install a water meter to monitor water makeup. Freeze protection fluid may leak before the water begins to leak, causing the concentration to drop, which reduces the freeze protection level.
- The freeze protection set points may be lowered when freeze protection fluid is used (see the Lectrus Service Manual).
- Consult the glycol manufacturer for details on the suggested mix of glycol and water for the desired freeze protection level and the de-rate effect it will have on the boiler output.

Test / replace freeze protection fluid

- For systems using freeze protection fluids, follow the fluid manufacturer's instructions.
- Freeze protection fluid must be replaced periodically due to degradation of inhibitors over time.
- It is recommended to test the glycol concentration annually and adjust within the desired set points.

Oxygen prevention

CAUTION

Eliminate all system leaks. Continual fresh makeup water will reduce boiler life. Minerals can build up in the pressure vessel, reducing heat transfer, overheating the pressure vessel, and causing pressure vessel failure.

Dissolved oxygen can have a negative effect on the boiler system. Oxygen can cause iron oxide to generate iron deposits. Oxygen may also increase the rate of corrosion on non-stainless-steel parts of the system. A low pH level combined with oxygen further enhances its corrosive effects. After boiler installation, check for air leaks in the following areas:

- Suction gasket
- Pump
- Air valve
- O-ring gaskets

Precautions include installing a water meter to evaluate the freshwater volume entering the system (should be no more than 5% system volume). Additional volumes of fresh water could indicate that a leak is present.

Fill and test water system

- Fill system only after ensuring the water meets the requirements of this manual.
- Close automatic and manual air vents and boiler drain valve.
- Fill to correct system pressure. Correct pressure will vary with each application.
 - The minimum cold water fill pressure for a system is 12 psi.
 - Pressure will rise when the boiler is turned ON and system water temperature increases.
- At initial fill and during boiler startup and testing, check the system thoroughly for any leaks. Repair all leaks before proceeding further.

5 Start-up *(continued)*

Purge air from water system

1. Purge air from system:
 - a. Connect a hose to the purge valve (see purge/drain valve in the piping diagrams on pages 18 through 23). Route the hose to an area where water can drain and be seen.
 - b. Close the boiler or system isolation valve between the purge valve and fill connection to the system.
 - c. Close zone isolation valves.
 - d. Open the quick-fill valve on the cold-water makeup line.
 - e. Open purge valve.
 - f. Open the isolation valves one zone at a time. Allow water to run through the zone, pushing out the air. Run until no noticeable air flow is present. Close the zone isolation valves and proceed with the next zone. Follow this procedure until all zones are purged.
 - g. Close the quick-fill water valve and purge valve and remove the hose. Open all isolation valves. Watch that system pressure rises to correct cold-fill pressure.
 - h. After the system has operated for a while, eliminate any residual air by using the manual air vents located throughout the system.
 - i. If purge valves are not installed in the system, open the manual air vents in the system one at a time, beginning with the lowest floor. Close the vent when water squirts out. Repeat with remaining vents.
2. Open the automatic air vent (diaphragm-type or bladder type expansion tank systems only) one turn.
3. Open other vents:
 - a. Starting on the lowest floor, open air vents one at a time until water squirts out.
 - b. Repeat with remaining vents.
4. Refill to correct pressure.

Check thermostat circuit(s)

1. Disconnect the two external wires connected to each of the heat/loop demand terminals on the connection board.
2. Connect a voltmeter across these two incoming wires. Close each thermostat, zone valve, and relay in the external circuit one at a time and check the voltmeter reading across the incoming wires.
3. There should NEVER be a voltage reading.
4. If a voltage does appear under any condition, check, and correct the external wiring. (This is a common problem when using 3-wire zone valves.)
5. Once the external thermostat circuit wiring is checked and corrected if necessary, reconnect the external thermostat circuit wires to the connection board. Allow the boiler to cycle.

Final checks before starting the boiler

- Read the Lectrus Service Manual to familiarize yourself with SMART SYSTEM control module operation. Read this manual for the proper steps to start the boiler.
- Verify the boiler and system are full of water and all system components are correctly set for operation.
- Verify the preparation procedures of Section 5 have been completed.
- Verify electrical connections are correct and securely attached. Refer to Table 5A - Torque Requirements.

If boiler does not start correctly

1. Check for loose connections, blown fuse or service switch off?
2. Is boiler water temperature above 230°F (110°C)?
3. Is thermostat set below room temperature?

If none of the above corrects the problem, refer to the Troubleshooting Section of the Lectrus Service Manual.

Check system and boiler

Check water piping

1. Check system piping for leaks. If found, shut down the boiler and repair immediately.
2. Vent any remaining air from the system using manual vents. Air in the system will interfere with circulation and cause heat distribution problems and noise.

Minimum Equipment Required for Startup and Troubleshooting

- Volt-Ohm Meter
- Clamp-On Ammeter
- Megohm Meter
- Torque Wrench - inch lbs
- Torque Wrench - foot lbs
- Personal Protective Equipment

5 Start-up

Electrical System Checks

WARNING All POWER supplying boiler should be off and locked out! with the unit(s) main power switch(es) OFF and locked out.

- ❑ Inspect all components, external and internal, to assure that there has been no damage during shipment or installation.

With a Megohm Meter (500VDC minimum), check contactor load side terminals to ground. If a reading of <1 megohm is obtained, consult the Factory.

- ❑ Remove element access panel(s) and open doors to the electrical control panel(s). Run an inspection of the tightness of all electrical connections (IE: at fuse lugs, power entrance lugs, contactors, heating elements).

All branch circuit connections should be tightened to the values listed on the component or to the values listed on Table 5A - Torque Requirements. Torque to avoid component damage from heat build-up.

This tightness inspection is vital because the vibration during shipment can often loosen electrical connections. If this is not done, damage may occur to component parts when power is switched on, and those damaged parts will not be covered under the manufacturer's Limited Warranty.

NOTICE

See Maintenance Section on rechecking the torque on these components after an initial break-in period. Typically, one to two weeks after start-up and then at least annually.

- ❑ With an ohmmeter, check the resistance between the phases on the load side of the contactors. Each should read the same and approximately what is shown on the wiring diagram.
- ❑ Check the electrical panels for loose material, dust and / or moisture. Thoroughly vacuum the panels if dust or foreign materials have accumulated there.

Set space heating operation

Determine controlling sensor

For space heating systems, the temperature control can be based on one of three sensors: the inlet, outlet, or system supply sensor. The SMART SYSTEM control is programmed at the factory to control the temperature of the outlet sensor. The control will automatically switch to the system supply sensor once it is connected. If it is desired to base the temperature control on the inlet sensor, the appropriate parameter must be changed in the control. See the Lectrus Service Manual for a detailed explanation of this procedure.

Verify space heat circulator mode

The Space Heating Mode controls both the system pump (if connected), and the boiler pump. When the SMART SYSTEM control receives a space heating call for heat, it turns on the system pump. If the set point is not met, or the system sensor is not connected, it also turns on the boiler pump. After the space heating call for heat ends, the system pump continues to run for a short period of time. The system pump can be programmed to run continuously, except during outdoor shutdown. Other settings may affect the operation of the boiler and system pumps, as explained on the following pages. If the boiler pump was running, it continues to run for a short period of time as well. The system pump delay is factory set to 30 seconds. The boiler pump delay is factory set to 1 minute. If different delays are desired, the appropriate parameters in the control must be changed. See the Lectrus Service Manual for a detailed explanation of this procedure.

Adjust set point temperature(s)

NOTICE

Please note that the brackets ([]) denote screen status.

The NAVIGATION dial may be used during normal operation to adjust the space heating and tank set point temperatures.

1. From the Status Screen press the NAVIGATION dial.
2. Turn the NAVIGATION dial to select the appropriate set point.
3. Press the NAVIGATION dial to adjust the temperature. Rotate the NAVIGATION dial to change the setting.
4. Once the desired temperature is displayed, press the RIGHT SELECT [SAVE] key.
5. Press the RIGHT SELECT [HOME] key to upload the changes.
6. If the RIGHT SELECT [SAVE] key is not pressed, the new settings will be discarded.

5 Start-up *(continued)*

Table 5A Torque Requirements

Manufacturer	Model	Type	LOADSIDE					LINESIDE														
			Torque Per Gauge (lbs. in)					Torque Per Gauge (lbs. in)														
			14 Ga	12 Ga	10 Ga	8 Ga	6 Ga	10 Ga	8 Ga	6 Ga	4 Ga	2 Ga	0 Ga	00 Ga	000 Ga	0000 Ga	250 MCM	300 MCM	350 MCM	500 MCM		
EATON / BUSSMANN	16023-2	Flat head	20		25	35	275															
MARATHON	1402404	Flat head	35					275														
FERRAZ SHAWMUT	67662	Flat head	20		25	35	275															
EATON / BUSSMANN	16021-3	Flat head	20		25	35	120															
MARATHON	1403401	Flat head	35					35	40	120												
FERRAZ SHAWMUT	67563	Flat head	20		25	35	50		120													
EATON / BUSSMANN	16023-3	Flat head	20		25	35	275															
MARATHON	1403404	Flat head	35					275														
FERRAZ SHAWMUT	67663	Flat head	20		25	35	275															
EATON / BUSSMANN	16375-3	Flat head	20		25	35	500															
MARATHON	1453552	Flat head	35		40	45	375															
FERRAZ SHAWMUT	69083	Flat head	35		40		500															
EATON / BUSSMANN	16377-3	Flat head	20		25	35	275															
MARATHON	1343596	Flat head	35					275														
FERRAZ SHAWMUT	69143	Flat head	35		40		275															
ILSCO	TA-0	Hex Socket head						35	40	45		50										
ILSCO	TA-250	Hex Socket head						250														
ILSCO	TA-250	Hex Socket head						375														
EATON	C25DNF340A	Posidrive head	15		25	40	45															
SQUARE D	8910DPA43V02	Flat head	40																			
TE CONNECTIVITY	3100-30T10999CG	Flat head	40																			
EATON / BUSSMANN	T30030-3CR	Flat head	20		25	35																
MARATHON	RT30A3B	Flat head	35		40	45																
FERRAZ SHAWMUT	30308T	Flat head	35																			
EATON / BUSSMANN	T60030-3	Flat head	35		40	45																
MARATHON	RT60A3B	Flat head	35		40	45																
FERRAZ SHAWMUT	30608T	Flat head	45																			

5 Start-up

Table 5A Torque Requirements continued

Manufacturer	Model	Type	LOADSIDE					LINESIDE												
			Torque Per Gauge (lbs. in)					Torque Per Gauge (lbs.in)												
			14 Ga	12 Ga	10 Ga	8 Ga	6 Ga	10 Ga	8 Ga	6 Ga	4 Ga	2 Ga	0 Ga	00 Ga	000 Ga	0000 Ga	250 MCM	300 MCM	350 MCM	500 MCM
EATON / BUSSMANN	T30060-3	Flat head	35			40	45													
MARATHON	R6T30A3B	Flat head	35			40	45													
FERRAZ SHAWMUT	60308T	Flat head	35																	
EATON / BUSSMANN	T60060-3	Flat head	35			40	45													
MARATHON	R6T60A3B	Flat head	35			40	45													
FERRAZ SHAWMUT	60608T	Flat head	45																	
EATON / BUSSMANN	T60030-2	Flat head	35			40	45													
MARATHON	6T30A2B	Flat head	35			40	45													
FERRAZ SHAWMUT	60307T	Flat head	35																	
EATON / BUSSMANN	H25030-1CR	Flat head	35																	
MARATHON	RF30A1B	Flat head	25																	
FERRAZ SHAWMUT	20306R	Flat head	35																	
EATON / BUSSMANN	H25030-2CR	Flat head	35																	
MARATHON	RF30A2B	Flat head	25																	
FERRAZ SHAWMUT	20307R	Flat head	35																	
APCOM	-	Posidrive head	30																	

5 Start-up *(continued)*

Set domestic hot water (DHW) operation

Verify DHW mode

There are two (2) modes of operation for DHW. In Normal Mode, when a DHW demand begins, the control will start the DHW pump, turn off the boiler pump (if running), and modulate to bring the outlet temperature to the DHW boiler set point. The maximum element power may be limited in this mode if desired.

In Zone Mode it is assumed that the indirect DHW tank is piped as a zone on the primary loop. When a DHW demand begins, the control will turn on the DHW pump output, and raise the system temperature set point to the DHW boiler set point (if higher). The boiler pump will be turned on. The system pump may be forced on, forced off, or not changed, depending on the System Pump Mode selected (reference the Lectrus Service Manual for details). In this mode, any low temperature zones (such as radiant heating) may need additional controls to limit the water temperature sent to those zones.

Set DHW boiler target temperature

When in the DHW Mode, the control will modulate to maintain the boiler outlet temperature or system supply temperature to a set point. This set point is set at the factory to 180°F. If a different set point is desired, the appropriate parameter in the control must be changed. See the Lectrus Service Manual for a detailed explanation of this procedure.

Set clock

NOTICE

Please note that the brackets ([]) denote screen status.

The SMART SYSTEM control has a built-in clock that it uses for its night setback feature and for logging events. This clock must be set when the boiler is installed, and anytime the boiler has been powered off for more than 4 hours. Use the following procedure to set the clock:

1. Press and hold the LEFT SELECT [MENU] key for at least 5 seconds.
2. The display changes to read [PASSWORD], with four (4) zeros below it. Enter the installer password.
3. Press the RIGHT SELECT [SAVE] key.
4. The display will then show a menu. Select GENERAL by pressing the dial, then select TIME AND DATE.
5. Press the NAVIGATION dial.
6. Turn the NAVIGATION dial to adjust the hours. Press the NAVIGATION dial.

7. Turn the NAVIGATION dial to adjust the minutes. Press the NAVIGATION dial.
8. Turn the NAVIGATION dial to adjust the month. Press the NAVIGATION dial.
9. Turn the NAVIGATION dial to adjust the date. Press the NAVIGATION dial.
10. Turn the NAVIGATION dial to adjust the year. Press the RIGHT SELECT [SAVE] key.
11. Press the RIGHT SELECT [HOME] key.

NOTICE

The internal clock does not adjust for Daylight Savings Time and therefore, will require a manual adjustment.

The clock is automatically updated whenever a PC is connected and the Win_Pro-Installer program is started.

Configuration of the cascade

NOTICE

Please note that the brackets ([]) denote screen status.

When installed in a Cascade system, the individual controls must be programmed for cascade operation. This is accomplished by accessing the control parameters.

Press the [MENU] key for at least five (5) seconds. Input the Installer code as described in the Lectrus Service Manual. Once the control parameters have been accessed, use the NAVIGATION DIAL to select the “Control Mode” menu. Press the NAVIGATION DIAL to access these parameters.

Rotate the NAVIGATION dial to select the parameter “Cascade Address”. Press the NAVIGATION dial to access this parameter. Each appliance in the Cascade system must be programmed with its own address. The boiler designated as the Leader will have an address of 0. The remaining boilers in the Cascade will be Members and have addresses from 1 - 7. Rotate the NAVIGATION dial to select the appropriate address. Press the RIGHT SELECT [SAVE] key.

Press the RIGHT SELECT [HOME] key twice to upload the address into the control. Repeat this procedure for all boilers in the Cascade, designating the Leader control and the Member controls.

5 Start-up

Operating Instructions

With the unit's control power ON/OFF switch at the back of the unit on 'OFF', close the main power switch(es), and then turn the ON/OFF switch to 'ON'.

NOTICE

Units with shunt trip disconnects and remote 120-volt control power may require turning the control power switch 'ON' and activating the 120-volt control power, before closing the main power switch(es).

Alarm and Reset Circuits

If the alarm sounds when the control switch is turned 'ON', depress the alarm silence button if equipped. Check the unit to make certain that no limit condition exists. The alarm will sound momentarily on some units when power is initially applied.

Units with Manual Reset Button(s) may require resetting of the manual reset switch upon initial application of power, and after the interruption or power or the trip-out of a limit control.

Sequencing of Elements Circuits

On units with step controls, the unit will always start with no steps energized.

As the steps begin cycling on, the LEDs on the modulation control board (circuit board inside cabinet) will light up one at a time, indicating that step control is operating properly.

When the outlet water temperature is at or near setpoint, the controls will cycle to the no-load condition. The steps should then begin to cycle on as needed, and all the steps may come on if necessary.

The triac board(s) will modulate up and down as needed up to two elements to provide a smooth boiler operation to maintain the set temperature.

Turn off the appliance

To turn the boiler off, simply switch the unit's control power ON/OFF switch at the back of the unit to 'OFF'.

Freeze Protection

The control will turn on the boiler and system pump outputs whenever the inlet temperature drops below this setting. This is done to prevent the water in the heat exchanger from freezing. In addition, the boiler may turn on low power to keep the water from freezing. Certain low-temperature applications (such as snow melt) can operate at temperatures around freezing, so this setting needs to be lowered in these cases. The installer can adjust the temperature at which the pump outputs are turned on by accessing Freeze Protection Pump On parameter.

6 Operating information

General

How the boiler operates

The Lectrus uses a carbon steel pressure vessel and electronic control modules to operate at the capacity needed for the space heating demand. The modulation control board powers on the contactors and the Triac board as needed. The contactors engage to provide power to the resistive heating elements. The Triac board operates the SCR element as required.

How the control module operates

The SMART SYSTEM control module receives inputs from boiler sensors and external devices. The control module activates and controls the modulation board to regulate heat, Domestic Hot Water (DHW), and system pumps on and off as needed. The user programs the module to meet system needs by adjusting control parameters. These parameters set operating temperatures and boiler operating modes. Boiler operation can be based on boiler outlet water temperature, boiler inlet water temperature, system temperature, a 0 - 10V signal, Modbus, or BACnet, depending on the parameter settings.

Control inputs and outputs

Room thermostat

There is one (1) heat/loop demand connection available on this control. This input tells the boiler to provide water for space heating. This demand connection has its own set point and outdoor air reset curve.

0 - 10V input (set point or power)

The Lectrus can be controlled by a Building Management System (BMS) using a 0 - 10 VDC signal. The control can be configured by the installer to use this signal to either control set point or element power.

The Lectrus can also be programmed to accept a call for heat from a 0 - 10V signal, reference the Lectrus Service Manual for a detailed explanation of this procedure.

DHW priority

The SMART SYSTEM control allows the connection of a DHW thermostat or tank sensor to the low voltage connection board. When a tank sensor is connected, the DHW thermostat input is ignored. When a boiler is programmed for DHW Normal Mode, the maximum element power can be limited to match the input rating of the indirect tank coil.

DHW / space heating (SH) cycling

If a DHW call for heat is received while a space heating call is in progress, and the DHW is in Normal Mode, the control will start the DHW pump and shut the boiler pump off. The system pump will remain on. For stand-alone boilers, if the space heating call is still active while the DHW call is in operation, the control will wait for 30 minutes (time adjustable by installer) then it will switch back to the space heating demand. There is a timer to switch from space heating to DHW and a timer to switch from DHW to space heating. The control will switch back and forth until one of the heat demands end. This function does not apply to cascade systems.

Heating Banks Operation

In general, the banks will enable as follows:

The unit will get to setpoint. For this to happen the modulating bank will start first. The "Modulation Control Board" (or MCB) will enable bank 1 and start the modulation for the Triac board. It will modulate the board until the Triac reaches 100% modulation.

If more than one bank is present and modulation needs to increase, the MCB will reduce the modulation on the Triac to its minimum and enable the next available bank of elements. The next bank is not necessarily bank 2. The MCB will evaluate which bank has run the least as well as which contactor has been activated less often.

If the boiler is running at a certain percentage of modulation for a long time, the MCB will do a bank rotation. The MCB will evaluate if there is a bank that is not currently running. If there is no bank available, the current bank will keep running. If there is a bank available, it will disable the bank that reached the limit time ON and enabled the next available bank with the least running time and activation. This rotation is done on a fixed duration.

There is no actual sequence on which bank will be enabled at which time. It all depends on running time and actuation, so the average run time and actuation of each element is the same over time.

Programmable controlling sensor

The control module is programmed to use the outlet sensor as the control sensor by default. If a system supply sensor is connected, the control automatically uses it as the control sensor. For stand-alone boilers, the control sensor can be changed by the installer to the inlet sensor. If the inlet sensor is chosen as the controlling sensor, it is recommended that the system supply sensor be installed in the system supply to provide the best control of the inlet temperature.

6 Operating information

Boiler and system pump control

The boiler pump will run whenever the burner is element power, unless the DHW is programmed for Normal Mode and the boiler is heating the DHW tank. The boiler pump will run during Freeze Protection Mode as well. It will continue to run for a short time after the burner turns off or the Freeze Protection Mode ends.

The system pump will run whenever there is a space heating call for heat, or the boiler goes into Freeze Protection Mode. It may be programmed to run during a DHW call for heat when the DHW is programmed for Zone Mode. It will continue to run for a short time after the end of the heat demand or the Freeze Protection Mode. The system pump can be programmed to run continuously if desired, except during outdoor shutdown and/or a DHW call for heat.

Temperature control

Modulation

The Lectrus is capable of modulating heat input from a variable minimum percentage of the maximum (1-11% depending on model size) up to 100%. The modulation bank provides a full range of heating input between each relay bank up to the maximum.

Ramp delay

For systems with lower flow, the SMART SYSTEM can limit the KW input (when enabled) when a space heating call for heat starts, when the set point is controlled by the BMS, or when switching from a DHW call for heat to a space heating call for heat. There are six (6) limits that can be programmed, as well as six (6) time intervals corresponding to each limit. The sixth limit will also limit the element power for the rest of the call for heat.

Gradient limiting

If during operation of the boiler the outlet water temperature is rising too quickly, the control will reduce the element power to its lowest setting.

Outdoor air reset

If an outdoor air sensor is connected, the control module will calculate the set points of the space heating demands based on the programmed reset curves. The installer can change the slope of the reset curves by several adjustable parameters. The user can limit the maximum set points for each demand using the space heating set points.

Boost function

If outdoor air reset is active, and any space heating demand has been active continuously for a set period of time (time adjustable by installer) and there has been no DHW demands, the control can increase the set point of that demand by a fixed number of degrees (adjustable by installer). This process will continue until the space heating demand ends, the set point reaches the programmed set point or a maximum of 20 increases has occurred. Once the system heat demand is satisfied, the set point will revert to the value determined by the reset curve.

Night setback

The controller may be programmed to reduce the space heating and DHW set points during certain times each week. Seven different start and stop times may be programmed for the space heating setback and seven start and stop times for the DHW setback.

Vacation mode

Vacation Mode is used to lower the Space Heat (SH) and/or DHW set points much like night setback. The set points will remain lowered until Vacation Mode is disabled. Night setback will not function when Vacation Mode is enabled.

Protection features

Outlet temperature and temperature rise limiting

The outlet temperature is monitored by the boiler outlet temperature sensor. When the outlet temperature exceeds 215°F, the unit will reduce its rate. If the outlet water temperature exceeds 225°F (107°C) the control will shut the unit down until it cools off.

The control monitors the temperature difference between the inlet and the outlet sensor. If this difference exceeds 70°F (39°C) the control will reduce the modulation. If the temperature difference exceeds 80°F (44°C) the control will shut the unit down. The unit will restart automatically once the temperature difference has dropped below 70°F (39°C) and the minimum off time has expired.

6 Operating information *(continued)*

The following integral feature of the boiler control module provides some protection for the boiler only -- not for the system.

The boiler control module provides a freeze protection feature with the following attributes:

- Below an inlet temperature of 45°F (7°C), the boiler pump operates constantly.
- Below an inlet temperature of 37°F (3°C), the modulation starts.
- Boiler and pumps turn off if boiler water inlet temperature rises above 45°F (7°C).

Neither this feature, the boiler control module, nor the use of glycol, eliminates the possibility of freezing. The installation must still use recognized design, installation, and maintenance practice to prevent freeze potential for the boiler and system.

The Freeze Protection feature will not work if the appliance does not have power, is locked out, is in shutdown mode, had a component failure, or is otherwise prevented from functioning.

NOTICE

When system return temperatures are maintained below the dew point, condensation will form on the inside of the boiler jacket causing some internal sheet metal components to rust.

Monitor external limits

Connections are provided on the connection board for a flow switch. The SMART SYSTEM will shut off and inhibit the boiler whenever either the flow switch or low water cutoff is open.

Run-time and alarm outputs

The boiler provides dry contacts for indicating when the boiler is running, and when it is unable to operate.

Run-time and cycle counting

The control uses timers to monitor the total hours of electric elements operation. One timer monitors the time the boiler is in the Space Heating Mode. Another timer monitors the time the boiler is element power in the DHW Mode.

The control uses counters to monitor the amount of boiler cycles.

Service reminder

The control can be programmed for service reminder notification. This notification will become active when either a set time frame has expired, or a set amount of running hours or cycles has expired (all adjustable by the installer). The display will show a Maintenance Required screen. The installer's name and phone number can be programmed into the control. This information will appear on the Maintenance Required screen. The service reminder notification can be reset or disabled by the installer.

Error logging

The control will hold in memory the last 10 lockouts. The date and time of the occurrence will be recorded as well. Only the 10 most current occurrences will be held in memory.

Boiler temperature regulation

Operating temperature (target)

The SMART SYSTEM control module senses water temperature and regulates boiler rate to achieve a target temperature. The target temperature can be set between 32°F (0°C) and 215°F (102°C).

- Target temperature is fixed when the outdoor sensor is not installed.
- Target Temperature is calculated when the outdoor sensor is connected based on the Outdoor Reset programming. Also, target is calculated when BMS or BAS is used to control setpoint based on BMS or BAS programmable parameters. See the Lectrus Service Manual for more information.

6 Operating information

High limit operations

The Lectrus is equipped with adjustable automatic reset and manual reset high limits. The automatic reset high limit has a maximum set point of 225°F (107°C) and the manual reset high limit has a maximum set point of 230°F (110°C).

When the outlet temperature exceeds 225°F (107°C), the automatic high limit action occurs. The boiler shuts down until the outlet water temperature cools below 205°F (96°C), and a 60 second timer has expired. If the outlet temperature continues to increase, the manual reset high limit action will occur at 230°F (110°C).

High limit test procedure

NOTICE

Please note that the brackets ([]) denote screen status.

1. Turn ON the main power to the boiler by placing the ON/OFF switch in the ON position.
2. From the Status Screen, press the MENU options and enter the password.
3. Rotate the dial to access the TEMPERATURE SETTINGS menu.
4. Rotate the dial to access the Manual Reset (MRHL).
5. Press and rotate the dial to change the setpoint.
6. Set the MRHL below the current outlet temperature.
7. Press the SAVE key on the right.
8. Press HOME. The new parameter will then be saved in the boiler control.
9. The boiler should now go into lockout for manual reset high limit.
10. If the current outlet temperature is below the new MRHL set point, locate the pinhole (SERVICE button) below the RESET button on the display board. Insert a thin probe (such as a paper clip) into the hole and press the button continuously for five (5) seconds to place the boiler into Service Mode. In Service Mode, the boiler will fire at ignition speed and will then modulate up to full fire.
11. Once the outlet temperature rises to the MRHL setpoint, the MRHL will function, causing the boiler to shut down and lock out.
12. Repeat Steps 2 through 7 to adjust the MRHL to its normal setting.
13. To test the manual reset high limit that is set outside the unit, locate the “Resideo” manual reset high limit.
14. Using a small screwdriver turn the dial clockwise to its minimum temperature (130°F).
15. If the outlet temperature is not high enough, repeat step 10.
16. When the outlet temperature reaches the limit, the boiler will go into lockout for LWCO/MRHL.
17. Using a small screwdriver turn the dial counterclockwise to set the MRHL level.

Low water cutoff protection

1. The SMART SYSTEM control module uses temperature sensing of both supply and return areas of the pressure vessel. If the flow rate is too low or the outlet temperature too high, the control module modulates and shuts the boiler down. This ensures boiler shutdown in the event of low water or low flow conditions.
2. In addition, an electronic low water cutoff control is provided.

6 Operating information *(continued)*

Outdoor reset operation, if used

Target temperature with outdoor reset

This feature improves the system's efficiency as the outdoor temperature warms up.

See the Lectrus Service Manual to change the settings.

NOTICE

(For Hot Water Boiler) Outdoor reset controller is set at the temperature at which the Boiler should operate when the outdoor temperature is 70°F (21°C) (this outdoor reference temperature is adjustable). The reset ratio is the number of degrees the boiler control temperature will increase for a 1 degree decrease in outdoor temperature.

Reset curve

The reset curves look at outdoor air temperature and adjust the set points.

Cascade

When multiple boilers are installed, they can be wired together in a cascade sequence. A maximum of eight boilers can be controlled from a single control. In this application one boiler would be designated as the Leader control and all others would be designated as Member controls. Member 1 can be configured to take over control of the Cascade should the Leader stop communicating with the Members. The Leader control can be programmed to use Lead/Lag or Efficiency Optimization control methods.

Once the Leader boiler receives a call for heat from a room thermostat, BMS, Modbus, or BACnet the control will determine what the set point will be. If outdoor air reset is desired, connect the outdoor air sensor to the terminals on the Connection Board on the Leader boiler. The set point will be calculated based on the programmed reset curve parameters. See the Lectrus Service Manual to program the reset curve. If outdoor air reset is not desired, do not connect the outdoor air sensor. A fixed temperature set point can be programmed into the control. See page 36 of this manual to program the set point.

If the water temperature at the system supply sensor is less than the set point + offset - differential, then the control will initiate a call for heat on the Cascade (see the Lectrus Service Manual for an explanation of the offset and differential). The Leader will energize the lead boiler on the Cascade. For a new startup this will be the Leader boiler.

Sequence of the cascade

To equalize the run time of all boilers on the Cascade, the sequence will automatically be changed at set intervals.

For the first 24 hours, the sequence will be changed once every hour. The switching on/off sequence will be as follows:

TIME	SWITCHING ON SEQUENCE
Start	L-M1-M2-M3-M4-M5-M6-M7
1 hour	M1-M2-M3-M4-M5-M6-M7-L
2 hours	M2-M3-M4-M5-M6-M7-L-M1

After the first 24 hours, the sequence will change every night at 2:00 a.m. If a boiler locks out or is used to heat an indirect DHW tank, it will automatically be given the lowest priority until 2:00 a.m.

DHW, Night Setback, and Ramp Delay operation with cascade

For normal mode DHW operation any boiler(s) in the Cascade can be selected to provide heat for a DHW call. Select a boiler to be designated as the DHW boiler. Connect the DHW thermostat or sensor to the terminals on the Connection Board marked for the corresponding device. When the boiler receives a DHW call, the Leader control will take that boiler out of the Cascade sequence. If another boiler is available, the Leader will start it up to take its place.

The DHW boiler will adjust its set point to the programmed DHW boiler set point and will adjust its element power to maintain this. Once the DHW call has been satisfied, the Leader control will place that boiler back into the Cascade sequence.

Switching of the boiler between DHW operation and SH operation when there is a call for both does not occur in Cascade Mode.

When DHW is programmed for Zone Mode, connect the DHW thermostat or tank sensor to the Leader boiler. When a DHW call is received, the Leader will modulate the entire Cascade to bring the system supply temperature up to the DHW boiler set point (if higher).

Night Setback operation of the boilers within the Cascade is available. Programming of the Night Setback will be done through the Leader boiler. Refer to the Lectrus Service manual for information regarding Night Setback.

Ramp Delay operation of the boilers as described in the Lectrus Service Manual is available when the boilers are part of a Cascade system.

6 Operating information

Sequence of operation

OPERATION	DISPLAY
<p>1. At power up, the unit verifies all sensors and if everything is good, it goes into Standby state.</p>	<p>STANDBY</p> <p>BANK_ENABLE MCB 1 <input type="checkbox"/> <input type="checkbox"/> <input type="checkbox"/> <input type="checkbox"/> <input type="checkbox"/> <input type="checkbox"/></p> <p>SYSTEM: 71°F INLET: 63°F OUTLET: 48°F TANK: NONE</p> <hr/> <p>MENU ↵NEXT SHDN</p>
<p>2. Upon a call for heat, the associated pump will become enabled.</p>	<p>WATER CHECK</p> <p>BANK_ENABLE MCB 1 <input type="checkbox"/> <input type="checkbox"/> <input type="checkbox"/> <input type="checkbox"/> <input type="checkbox"/> <input type="checkbox"/></p> <p>CH_PUMP ON HW_PUMP OFF SYS_PUMP ON</p> <hr/> <p>MENU ↵NEXT SHDN</p>
<p>3. A few milliseconds after, the low water cutoff will become enabled.</p>	<p>STANDBY</p> <p>BANK_ENABLE MCB 1 <input type="checkbox"/> <input type="checkbox"/> <input type="checkbox"/> <input type="checkbox"/> <input type="checkbox"/> <input type="checkbox"/></p> <p>SYSTEM: 71°F INLET: 63°F OUTLET: 48°F TANK: NONE</p> <hr/> <p>MENU ↵NEXT SHDN</p>
<p>4. The system status will change to "Water Check". This status is making sure that a flow is present, and the low water cut off is working properly. At this state, the unit is waiting for the low water cutoff to close.</p>	<p>WATER CHECK</p> <p>BANK_ENABLE MCB 1 <input type="checkbox"/> <input type="checkbox"/> <input type="checkbox"/> <input type="checkbox"/> <input type="checkbox"/> <input type="checkbox"/></p> <p>SYSTEM: 71°F INLET: 63°F OUTLET: 39°F TANK: NONE</p> <hr/> <p>MENU ↵SCREEN SHDN</p>
<p>5. The control will enable the limit relay and if the temperature is under the setpoint, it will enable the regulating relay. The runtime contact will close.</p>	<p>STARTUP</p> <p>BANK_ENABLE MCB 1 <input type="checkbox"/> <input type="checkbox"/> <input type="checkbox"/> <input type="checkbox"/> <input type="checkbox"/> <input type="checkbox"/></p> <p>SYSTEM: 61°F (85) INLET: 62°F OUTLET: 39°F TANK: NONE</p> <hr/> <p>MENU ↵NEXT SHDN</p>
<p>6. Then the unit starts its modulation and enable bank 1 to heat up the water. The rate is based on setpoint or other commands like BMS signal.</p>	<p>RUN TARGET 11% REAL 8%</p> <p>BANK_ENABLE MCB 1 <input checked="" type="checkbox"/> <input type="checkbox"/> <input type="checkbox"/> <input type="checkbox"/> <input type="checkbox"/> <input type="checkbox"/></p> <p>SYSTEM: 71°F (85) INLET: 62°F OUTLET: 39°F TANK: NONE</p> <hr/> <p>MENU ↵NEXT SHDN</p>

6 Operating information *(continued)*

Sequence of operation

OPERATION	DISPLAY
<p>7. If the space heating call for heat is active, and the tank thermostat or sensor starts a DHW call for heat, the boiler will switch to the DHW mode. If programmed for normal DHW operation (not as a zone), the DHW pump will turn on first, then the boiler pump will turn off (boiler and DHW pump operation briefly overlap to ensure flow is maintained through the unit). This will divert the boiler's outlet water from the heating system and send it to the tank coil instead. The control will then modulate to maintain the outlet temperature to the DHW boiler set point.</p>	<pre> RUN TARGET 46 % REAL 48 % BANK ENABLE MCB 1 ■ ■ ■ □ □ CH PUMP ON HW PUMP ON SYS PUMP ON MENU ↓NEXT SHDN </pre>
<p>8. If the boiler is not part of a Cascade, and both the space heating and DHW calls for heat remain active long enough, the boiler will switch back and forth between the two heating modes until one of them is satisfied.</p>	<pre> RUN TARGET 46 % REAL 46 % BANK ENABLE MCB 1 ■ ■ ■ □ □ CH PUMP ON HW PUMP ON SYS PUMP ON MENU ↓NEXT SHDN </pre>
<p>9. Once both calls for heat are satisfied, the control will disable the signal to the modulation board, disabling the regulating relay.</p>	<pre> STARTUP BANK ENABLE MCB 1 □ □ □ □ □ SYSTEM: 61°F(85) INLET: 62°F OUTLET: 39°F TANK: NONE MENU ↓NEXT SHDN </pre>
<p>10. Then it will disable the limit relay and the status goes back to Water Check.</p>	<pre> WATER CHECK BANK ENABLE MCB 1 □ □ □ □ □ SYSTEM: 71°F INLET: 62°F OUTLET: 39°F TANK: NONE MENU ↓SCREEN SHDN </pre>
<p>11. Any pumps that are running will continue to run for their respective pump delay times before turning off, unless programmed to remain on continuously.</p>	<pre> STANDBY BANK ENABLE MCB 1 □ □ □ □ □ CH PUMP ON HW PUMP OFF SYS PUMP ON MENU ↓NEXT SHDN </pre>
<p>12. In Standby, ready to start a new cycle.</p>	<pre> STANDBY BANK ENABLE MCB 1 □ □ □ □ □ SYSTEM: 71°F INLET: 63°F OUTLET: 48°F TANK: NONE MENU ↓NEXT SHDN </pre>

6 Operating information

Sequence of operation

Activation of Heating Element Circuits

Contactors

The heating elements are energized by a power source that is supplied through the contacts of a contactor. The contactor is activated (on a call for heat) by the closure of a temperature switch or by a contact in the step control circuit.

Fuses

All power leads to the elements are fused. The fusing is on the line side of the contactors.

Sequencing Controls

The heating elements are driven directly from the power contactors. These are energized by the modulation control board depending on the requested power sent by the boiler control. The modulation control board will sequence the contactors as needed. The boiler control evaluates the request for heat from the space heat, direct hot water input or the building management system 0-10V input. It will also evaluate the need to service the heat request depending on the temperature of the water and send the requested power to the modulation board if the water needs to be heated.

The safety limit devices (Flow switch, low water cutoff, manual reset high limit) interrupt the power to the contactor coil circuits.

Startup logic

The boiler control will monitor the heat demand as well as the temperature of the water. If a demand is present and the water temperature is lower than setpoint then the unit will start. The boiler control will enable the appropriate pump(s) and then the low water cutoff. It will verify if the low water cutoff is in correct state as well as the presence of flow. After the boot time for the LWCO and validating that the inputs are good, the unit will energize the limit relay and slightly after the regulating controls from the modulation control board. When this is completed, the boiler control will send a power request to the modulation control board and the unit will start servicing the heat demand.

Modulation logic

Depending on the power requested by the boiler control, the modulation control board will enable certain contactor to heat the water. It will first enable bank 1 and start modulation of the power. The power will gradually increase as the request increases until it reaches full modulation. If the power request decreases or stabilizes, the modulation control board will follow the request.

As the power request increase, the MCB will eventually reach full modulation with Bank 1 (except for 15kW units since they only have bank 1). If more banks are available with the boiler, the MCB will enable them and reduce the modulation from bank 1 to its minimum. As power requests increase, the modulation from bank 1 will increase. To evaluate if a bank can be enabled, the MCB will first look at the number of actuations the contactor has cycled. If one or more contactors has the same count of actuation, the MCB will look at the run time for those contactor/elements. It will then select the one with the least runtime. If one or more have the same runtime, it will then select the next available bank.

As the temperature increases, the boiler control monitors the temperature of the output sensor or tank sensor depending on the demand type. The demand will have to reach setpoint plus offset.

Bank Rotation

As the temperature increases, the boiler will modulate to stay at temperature. If for any reason the setpoint is not met for a certain duration, the MCB will verify if there is any available contactor to enable so the unit is not running only one set of elements/banks all the time. This function will help averaging the running hours of all the elements.

Boost Feature

As the boiler runs and the boiler control maintains a temperature close to setpoint, the modulation may not be at 100%. In that case, the boiler control will, after some time, try to reach temperature by increasing the modulation. This boost feature allows the boiler to meet the setpoint and help for the unit to not run continuously.

After the demand

When the demand is removed or the temperature reaches setpoint, the unit will need to go back to standby. Before doing so, the boiler control will reduce the power demand to 0. When the modulation control board receives a power demand of 0, it will disable the contactor and stop the modulation on bank 1. The boiler control will then disable the regulating control. After a certain time, the boiler control will disable the limit control, then the low water cutoff. The unit will now be in standby.

6 Operating information *(continued)*

SMART SYSTEM™ Lectrus control module

Use the control panel (FIG. 6-1) to set temperatures, operating conditions, and monitor boiler operation.

Figure 6-1 Control Panel

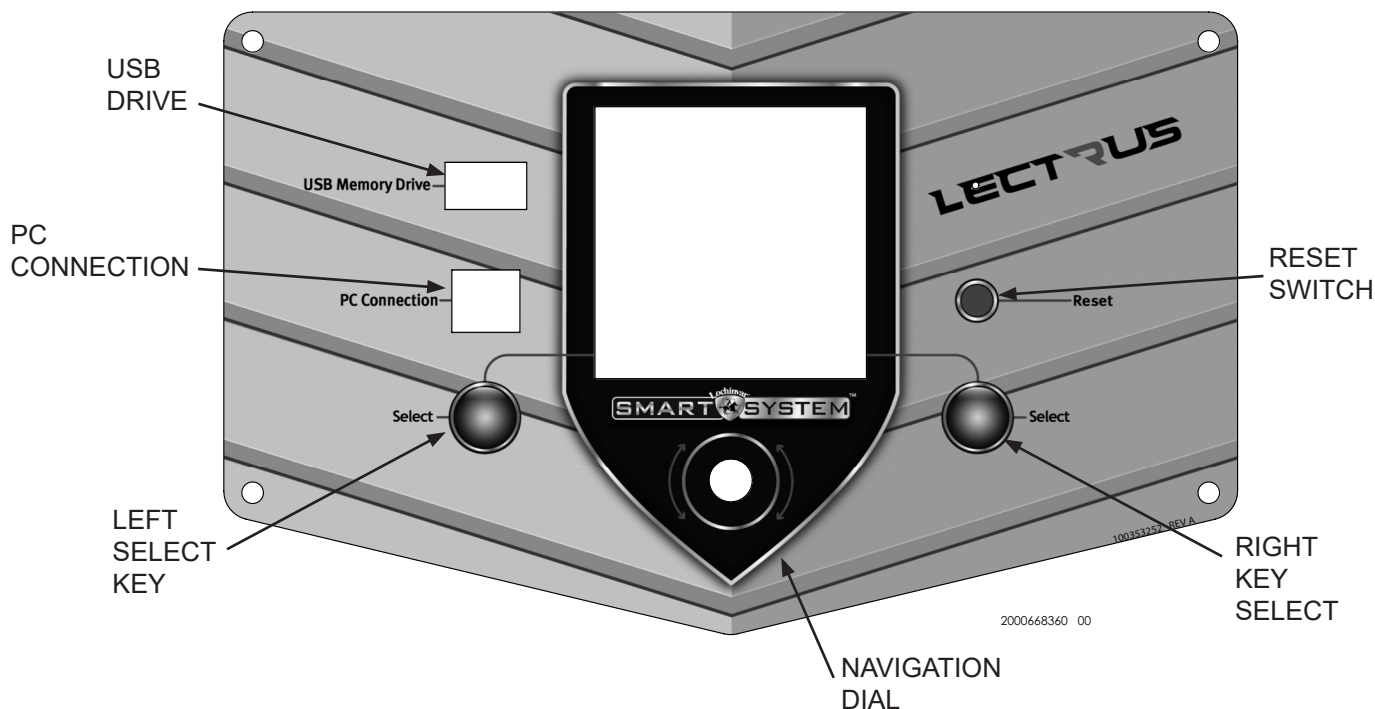

The information on the bottom of the display shows the functions of the two SELECT keys (on either corner), and the NAVIGATION dial (in the center):

MENU = Left SELECT Key
 SETPOINTS = NAVIGATION Dial - Pressing Down
 SHDN = Right SELECT Key

Access modes

User

The user can adjust space heating and tank target temperatures by pressing the NAVIGATION dial when "↓SETPOINTS" is flashing at the bottom of the display. The date and time, and the temperature units can also be changed.

Installer

Most parameters are available only to the installer, accessible by entering the installer password, see the Lectrus Service Manual.

Saving parameters *(reference the Parameter Table in the Lectrus Service Manual)*

NOTICE

Please note that the brackets ([]) denote screen status.

To save parameters and exit programming:

Press the RIGHT SELECT [SAVE] key and then press the RIGHT SELECT [HOME] key.

To enter a parameter and continue programming:

Press the RIGHT SELECT [SAVE] key 1 time to return to the parameter listings; press again to return to the menu listings. Remember to press the RIGHT SELECT [HOME] key when finished programming to save the changes made.

See the Lectrus Service Manual for a detailed description of parameters and access modes.

6 Operating information

Figure 6-2 Status Display Screen

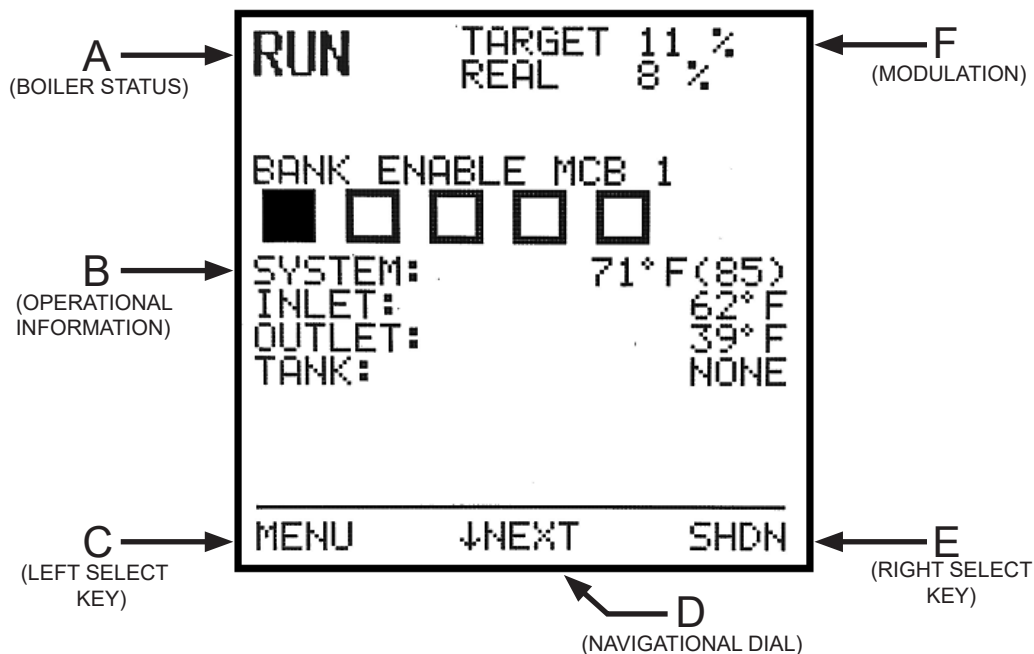

Status Display Screens

NOTE: All screens show modulation status, heat demands, lockout/blocking, bank status, and soft keys.

Section	Display	Description
A (Boiler Status)	STANDBY	The unit has not received a call for heat from a remote thermostat nor has it received a call for heat from a DHW thermostat.
	WATER CHECK	The unit is checking all safety circuits including the presence of water.
	STARTUP	The unit is enabling the regulating and limiting device.
	RUN	The unit is running and heating water.
	SHUTDOWN	The unit has been placed in the OFF position.
	SETPOINT MET	The controlled temperature has exceeded its set point and its offset.
	BLOCKING	The unit has detected a condition that has temporarily interrupted the current call for heat.
	BANK ENABLE	The number of squares indicates the number of banks available. If the bank is ON, the square is filled. If the bank is OFF, the square is empty.

6 Operating information *(continued)*

Status Display Screens <i>(cont'd)</i>		
NOTE: All screens show burner status, heat demands, lockout/blocking, pump status, and soft keys.		
Section	Display	Description
B (Operational Information)	HOME SCREEN	<ul style="list-style-type: none"> - System Temperature - Inlet Temperature - Outlet Temperature - Tank Temperature
	BMS SCREEN	<ul style="list-style-type: none"> - BMS in - Rate out - Sys pump speed - BLR pump speed
	PUMP STATUS	<ul style="list-style-type: none"> - BLR pump - DHW pump - SYS pump
	HISTORY SCREEN	<ul style="list-style-type: none"> - SH Runtime - SH Cycles - DHW runtime - DHW cycles - Power Hours
	FAULT SCREEN	Last 10 faults: (Press the navigation dial to go through faults) <ul style="list-style-type: none"> - Fault name - Date - Time
C (Left Select Key)	MENU	Press the left select key to access the installer menu.
D (Navigation Dial)	NEXT SCREEN	Rotate the knob to access the different screens
E (Right Select Key)	SHDN	Press and hold the Right key to shut down the unit or to turn it back ON.
	SAVE	Within the installer menus, the button will be used to save the current value.
F (Modulation)	TARGET	Target modulation per the Boiler Control
	REAL	Real modulation feedback from the MCB

7 Maintenance

Maintenance and annual startup

Table 7A Service and Maintenance Schedules

Service technician (see the following pages for instructions)	
Annual Startup	<p>General:</p> <ul style="list-style-type: none"> • Address reported problems • Inspect interior; clean and vacuum if necessary • Check for leaks (water) • Check system water pressure/system/piping/expansion tank • Check fill water meter • Test boiler water. When test indicates, clean system water with approved system restorer following manufacturer's information • Check control settings • Check wiring and connections

⚠ DANGER

If this boiler may be frozen, immediately shut off power to the appliance and contact the factory for further instructions. Operation when the pressure vessel, internal pipes, or pressure relief valves are frozen, will result in internal pressure build-up and a deadly steam explosion. Neither the Freeze Protection feature of the boiler control module, nor the use of glycol eliminates the possibility of freezing.

⚠ WARNING

Follow the Service and maintenance procedures given throughout this manual and in component literature shipped with the boiler. Failure to perform the service and maintenance could result in damage to the boiler or system. Failure to follow the directions in this manual and component literature could result in severe personal injury, death, or substantial property damage.

⚠ WARNING

The boiler should be inspected annually only by a qualified service technician. In addition, the maintenance and care of the boiler designated in Table 7A and Table 7B, and explained on the following pages must be performed to assure maximum boiler efficiency and reliability. Failure to service and maintain the boiler and system could result in equipment failure.

⚠ WARNING

Electrical shock hazard – Turn off power to the boiler and disconnect the main feed before any service operation on the boiler except as noted otherwise in this instruction manual. Failure to turn off electrical power could result in electrical shock, causing severe personal injury or death.

Address reported problems

1. Inspect any problems reported by the owner and correct before proceeding.

Inspect boiler area

1. Verify that boiler area is free of any combustible materials, gasoline and other flammable vapors and liquids.

Inspect boiler interior

1. Open the top panel and front door and inspect the interior of the boiler.
2. Vacuum any sediment from inside the boiler and components. Remove any obstructions.

Check all piping for leaks

⚠ WARNING

Eliminate all system or boiler leaks. Continual fresh makeup water will reduce boiler life. Minerals can build up in sections, reducing heat transfer, overheating pressure vessel, and causing pressure vessel failure. Leaking water may also cause severe property damage and risk of electrocution.

1. Inspect all water piping and verify to be leak free.
2. Look for signs of leaking lines and correct any problems found.

7 Maintenance *(continued)*

Check water system

1. Verify all system components are correctly installed and operational.
2. Check the cold fill pressure for the system. Verify it is correct (must be a minimum of 12 psi (82.7 kPa)).
3. Watch the system pressure as the boiler heats up (during testing) to ensure pressure does not rise too high. Excessive pressure rise indicates expansion tank sizing or performance problem.
4. Inspect automatic air vents and air separators. Remove air vent caps and briefly press push valve to flush vent. Replace caps. Make sure vents do not leak. Replace any leaking vents.

Check expansion tank

1. Expansion tanks provide space for water to move in and out as the heating system water expands due to temperature increase or contracts as the water cools. Tanks may be open, closed or diaphragm or bladder type. See Section 3 - Hydronic Piping for suggested best location of expansion tanks and air eliminators.

Check fill water meter

1. Check fill water meter for water usage. If the amount exceeds 5% of your system volume, you could have a leak. Have the system checked for leaks and repaired by a qualified service technician.

Test boiler water

1. Test boiler water. Reference section 5 of the Lectrus Installation and Operation Manual for guidelines. When test indicates, clean system water with approved system restorer following the manufacturer's information.

Check boiler relief valve

1. Inspect the relief valve and lift the lever to verify flow. Before operating any relief valve, ensure that it is piped with its discharge in a safe area to avoid severe scald potential. Read Section 3 - Hydronic Piping before proceeding further.

WARNING

Safety relief valves should be re-inspected AT LEAST ONCE EVERY THREE YEARS, by a licensed plumbing contractor or authorized inspection agency, to ensure that the product has not been affected by corrosive water conditions and to ensure that the valve and discharge line have not been altered or tampered with illegally. Certain naturally occurring conditions may corrode the valve or its components over time, rendering the valve inoperative. Such conditions are not detectable unless the valve and its components are physically removed and inspected. This inspection must only be conducted by a plumbing contractor or authorized inspection agency – not by the owner. Failure to re-inspect the boiler relief valve as directed could result in unsafe pressure buildup, which can result in severe personal injury, death, or substantial property damage.

WARNING

Following installation, the valve lever must be operated AT LEAST ONCE A YEAR to ensure that waterways are clear. Certain naturally occurring mineral deposits may adhere to the valve, rendering it inoperative. When manually operating the lever, water will discharge, and precautions must be taken to avoid contact with hot water and to avoid water damage. Before operating lever, check to see that a discharge line is connected to this valve directing the flow of hot water from the valve to a proper place of disposal. Otherwise, severe personal injury may result. If no water flows, valve is inoperative. Shut down the boiler until a new relief valve has been installed.

2. After following the above warning directions, if the relief valve weeps or will not seat properly, replace the relief valve. Ensure that the reason for relief valve weeping is the valve and not over-pressurization of the system due to expansion tank waterlogging or under-sizing.

7 Maintenance

Check all boiler wiring

1. Inspect all boiler wiring, making sure wires are in good condition and securely attached.

Check control settings

1. Set the SMART SYSTEM control module display to Parameter Mode and check all settings. See Section 1 of the Lectrus Service Manual. Adjust settings if necessary. See Section 1 of the Lectrus Service Manual for adjustment procedures.
2. Check settings of external limit controls (if any) and adjust if necessary.

Perform start-up and checks

1. Start boiler and perform checks and tests specified in Section 5 - Start-up.
2. Verify cold fill pressure is correct and that operating pressure does not go too high.

Review with owner

1. Review the Lectrus User's Information Manual with the owner.
2. Emphasize the need to perform the maintenance schedule specified in the Lectrus User's Information Manual (and in this manual as well).
3. Remind the owner of the need to call a licensed contractor should the boiler or system exhibit any unusual behavior.
4. Remind the owner to follow the proper shutdown procedure and to schedule an annual start-up at the beginning of the next heating season.

Cleaning boiler pressure vessel

1. Shut down boiler:
 - Follow the "To Turn Off Appliance" instructions for the boiler in Section 5 - Startup.
 - Do not drain the boiler unless it will be exposed to freezing temperatures. If using freeze prevention fluids in the system, do not drain.
2. Allow time for the boiler to cool to room temperature if it has been element power.
3. Remove the screws securing the inspection opening cover plate on the back of the unit (see Figure 7-1).
4. Unscrew the 3" NPT brass plug from the opening.

WARNING The boiler contains insulating fiber materials. Use care when handling these materials per instructions in the Lectrus Service Manual. Failure to comply could result in severe personal injury.

5. Use a vacuum cleaner to remove any accumulation inside the boiler. Do not use any solvent.
6. Using a clean cloth dampened with warm water, wipe out the inside. Rinse out debris with a low-pressure water supply.
7. Allow the pressure vessel to thoroughly dry.
8. Reassemble the unit. Confirm that the pressure vessel is filled, checked for leaks, and that any air is purged.
9. Resume operation.

Electrical System Maintenance

1. Clean the control cabinets periodically (as often as needed) to keep both the interior and the exterior free of dust, moisture, and foreign matter. The interior cleaning of the electrical panels must be done with the POWER OFF!

NOTICE For units supplied with control cabinet cooling fans, the condition of the fan filter must be periodically checked, and the filters cleaned or replaced as necessary.
2. With the POWER OFF, periodically check the tightness of electrical connections; particularly at power entrance lugs, fuses (line side) and contactors (load side). This should be done at time of commissioning, at 7 – 14 days thereafter and at least annually. Replace any components that show signs of heat damage (IE: discoloration, charring, melted insulation, etc.). See Table 5A - Torque Specifications.
3. Inspect the condition of the contactors. Look for burned or corroded contacts or overheated coils and wires. If the contactors chatter or hum during operation, they should be either disassembled and cleaned to remove dust or other foreign material in the mechanism or replaced.
4. Inspect the heating elements. Make sure that the terminal contacts are tight, clean, and corrosion-free.
5. Check all the wiring throughout the unit for frayed or brittle insulation. Replace any wiring showing insulation degradation.

Figure 7-1 Remove inspection cover

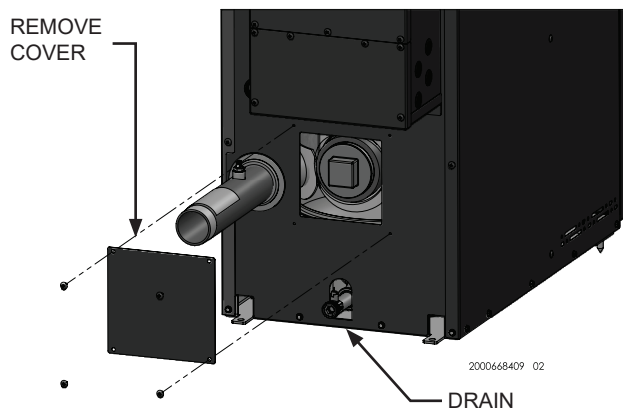

7 Maintenance *(continued)*

Typical Preventative Maintenance List

NOTICE

This list may not be all inclusive! Read and understand entire 'Lectrus Service Manual' and take into consideration any modifications and / or optional equipment for this unit:

WARNING

MAIN POWER MUST BE TURNED OFF TO DO ELECTRICAL CHECKS!

Table 7B Service and Maintenance Schedules

Owner maintenance (see the Lectrus User's Information Manual for instructions)	
Daily	<ul style="list-style-type: none"> • Ensure valves, connections, piping, gaskets, etc. are not leaking • Check pressure/temperature gauge
Weekly	<ul style="list-style-type: none"> • Verify that boiler water properties are within desired parameters
7-14 Days after STARTUP	<ul style="list-style-type: none"> • Re-torque screws on distribution, fuse blocks and contactors to their specified torque (typically 45 – 50 in – lbs.) • Re-torque any bolts on copper distribution from disconnects or circuit breakers to typical torque values for the size of bolt used. • Send Startup form to Lochinvar.
Monthly to Every Six Months	<ul style="list-style-type: none"> • Check for any heating element gasket leaks • Clean cooling fans to maintain proper air flow • Check fuses and heating elements with an ohm meter for proper values. • Look for signs of overheating on fuses, fuse blocks, contactors, and wires. Any discolored, charred, or melted components should be replaced. Ensure all screws are torqued to their proper values for any replaced components. • Check boiler piping (water) for leaks • Operate relief valve
Annually	<ul style="list-style-type: none"> • Inspect interior of tank for sludge or scale. Clean tank and modify water treatment chemistry as necessary. • Replace brittle element gaskets, valve gaskets and as necessary. • Re-torque ALL distribution, fuse block and contactor screws to the proper value. • Re-torque any bolts on copper distribution from disconnects or circuit breakers to typical torque values for the size of bolt used.
End of season months	<ul style="list-style-type: none"> • Shut boiler down (unless boiler used for domestic hot water)
Periodically	<ul style="list-style-type: none"> • Test low water cutoff • Reset button (low water cutoff)

8 Diagrams

Figure 8-1 Wiring Diagram - 208V, 3 Phase (A)

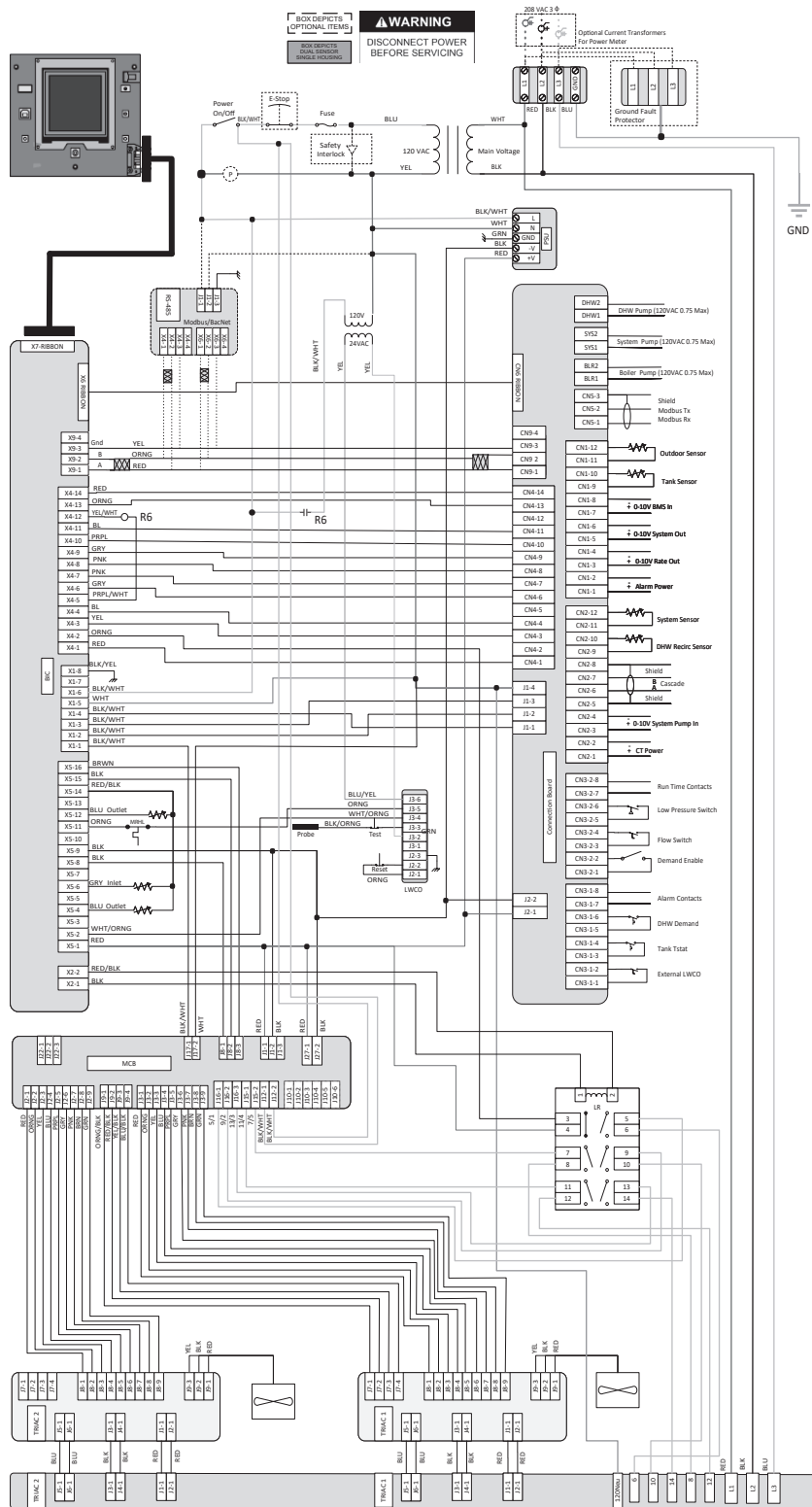

Notes:

1. All wiring must be installed in accordance with local, state, provincial and national code requirements per either N.E.C in USA or C.S.A in Canada.
2. If any original equipment wire was supplied with the appliance must be replaced, it must be replaced with wire having the same wire gauge (AWG) and rated for a minimum of 105°C. Exceptions: Any wiring listed on the replacement parts list and ribbon cable must be purchased from the factory. Use of a non-approved factory replacement harness lead or ribbon cable can lead to operational problems which could result in non-repairable damage to the integrated controller or other components.
3. Actual connector block locations may vary from those shown on diagrams. Refer to actual components for proper connector block locations when using diagrams to trouble shoot the unit.

8 Diagrams *(continued)*

Figure 8-2 Wiring Diagram - 208V, 3 Phase (B)

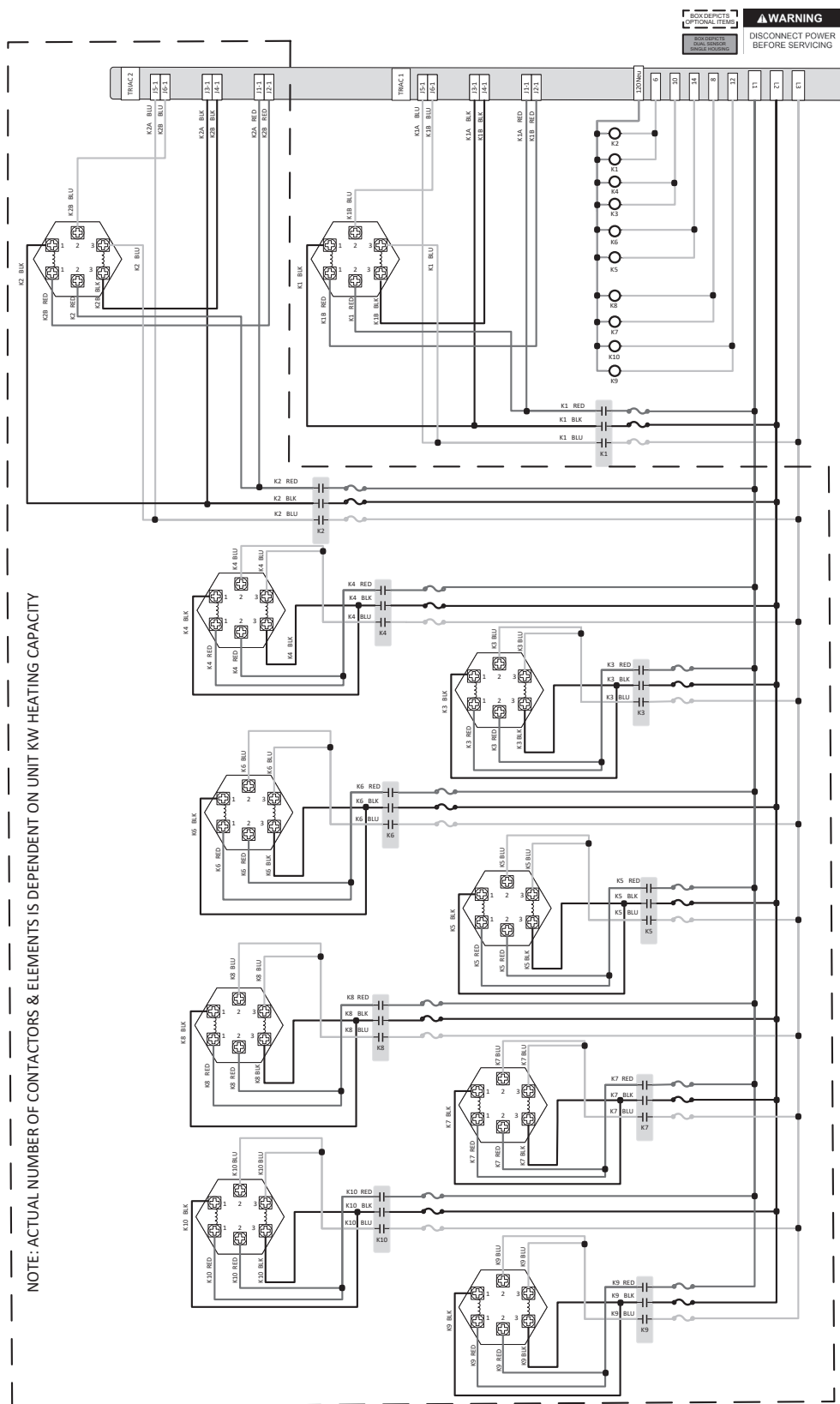

Notes:

1. All wiring must be installed in accordance with local, state, provincial and national code requirements per either N.E.C in USA or C.S.A in Canada.
2. If any original equipment wire was supplied with the appliance must be replaced, it must be replaced with wire having the same wire gauge (AWG) and rated for a minimum of 105°C. Exceptions: Any wiring listed on the replacement parts list and ribbon cable must be purchased from the factory. Use of a non-approved factory replacement harness lead or ribbon cable can lead to operational problems which could result in non-repairable damage to the integrated controller or other components.
3. Actual connector block locations may vary from those shown on diagrams. Refer to actual components for proper connector block locations when using diagrams to trouble shoot the unit.

8 Diagrams *(continued)*

Figure 8-5 Wiring Diagram - 400-600V, 3 Phase (A)

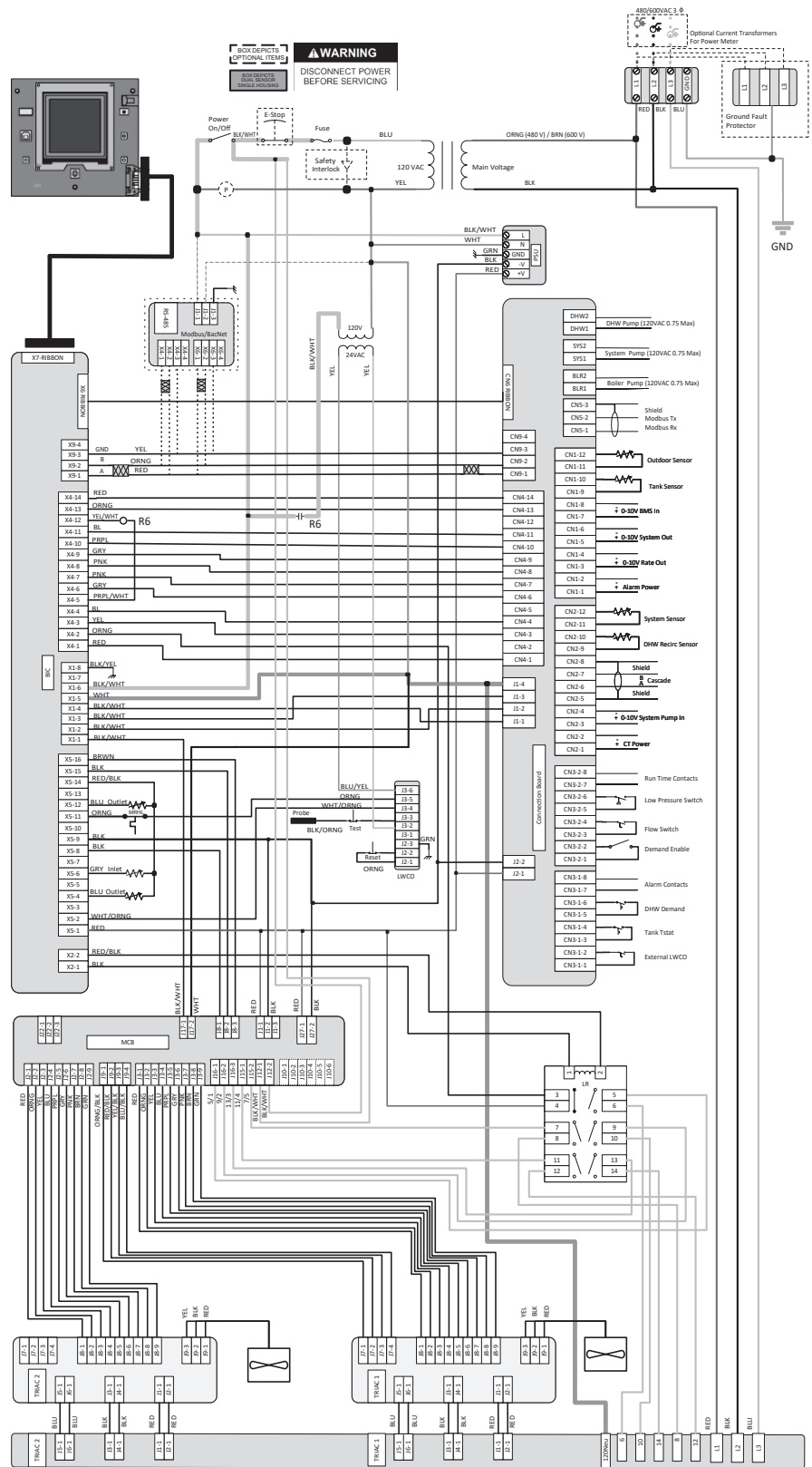

Notes:

1. All wiring must be installed in accordance with local, state, provincial and national code requirements per either N.E.C in USA or C.S.A in Canada.
2. If any original equipment wire was supplied with the appliance must be replaced, it must be replaced with wire having the same wire gauge (AWG) and rated for a minimum of 105°C. Exceptions: Any wiring listed on the replacement parts list and ribbon cable must be purchased from the factory. Use of a non-approved factory replacement harness lead or ribbon cable can lead to operational problems which could result in non-repairable damage to the integrated controller or other components.
3. Actual connector block locations may vary from those shown on diagrams. Refer to actual components for proper connector block locations when using diagrams to trouble shoot the unit.

8 Diagrams

Figure 8-6 Wiring Diagram - 400-600V, 3 Phase (B)

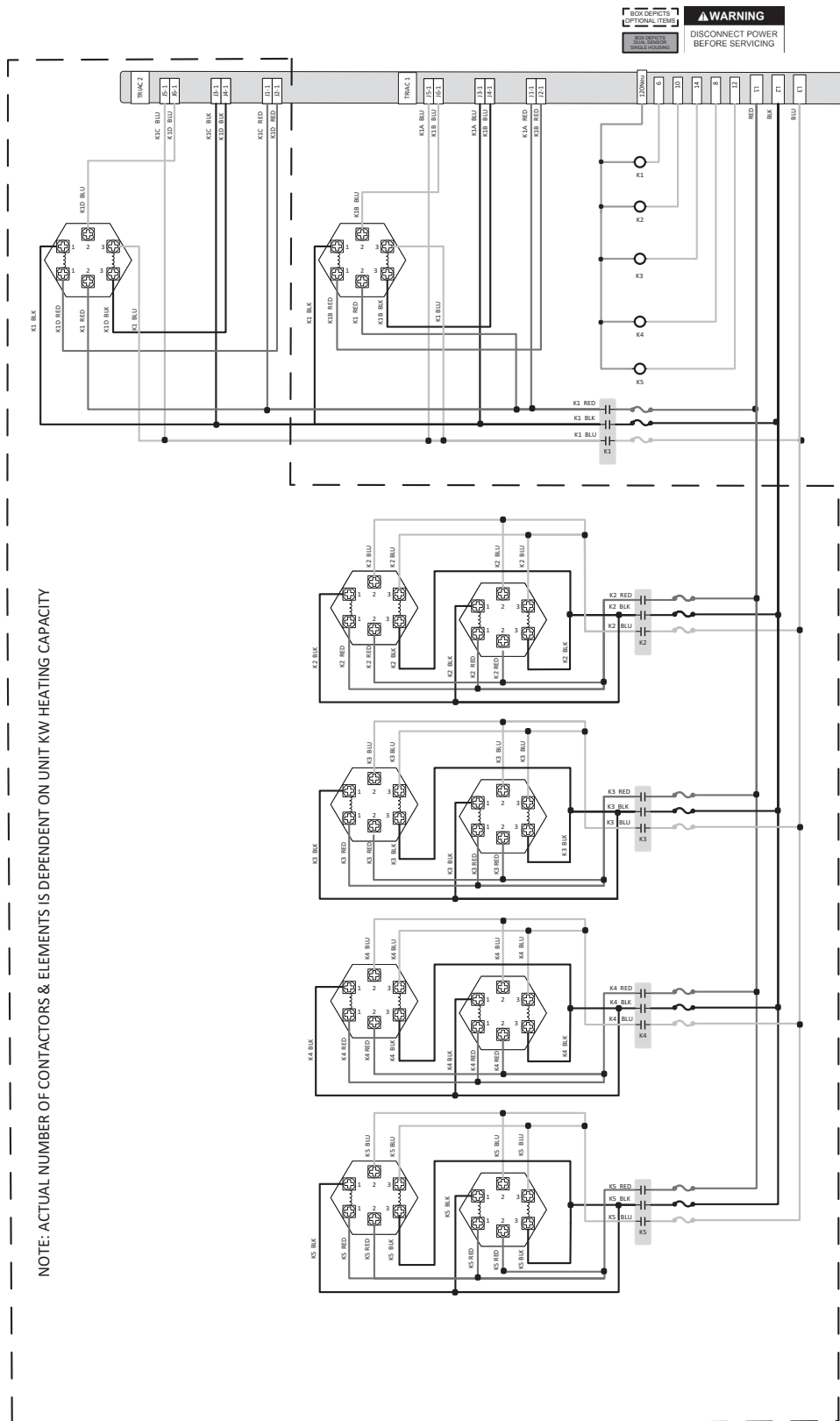

Notes:

1. All wiring must be installed in accordance with local, state, provincial and national code requirements per either N.E.C in USA or C.S.A in Canada.
2. If any original equipment wire was supplied with the appliance must be replaced, it must be replaced with wire having the same wire gauge (AWG) and rated for a minimum of 105°C. Exceptions: Any wiring listed on the replacement parts list and ribbon cable must be purchased from the factory. Use of a non-approved factory replacement harness lead or ribbon cable can lead to operational problems which could result in non-repairable damage to the integrated controller or other components.
3. Actual connector block locations may vary from those shown on diagrams. Refer to actual components for proper connector block locations when using diagrams to trouble shoot the unit.

100374983 REV B

8 Diagrams (continued)

Figure 8-7 Ladder Diagram - 208V, 3 Phase

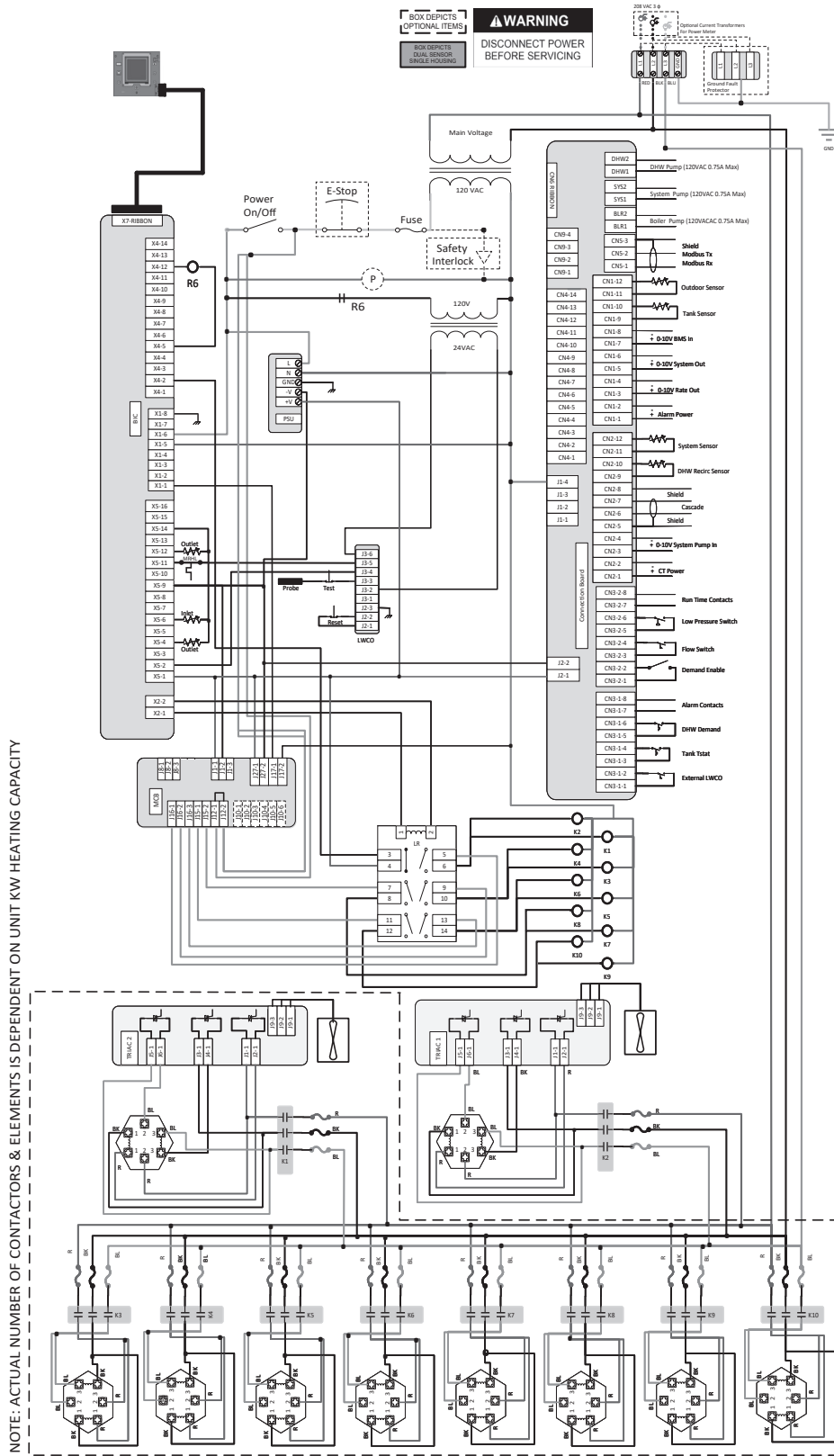

Notes:

1. Where possible, switches are shown without utilities (water or electricity) connected to the unit. As such, actual switch states may vary from those shown on diagrams depending upon whether utilities are connected, or a fault condition is present.
2. See wiring diagram for additional notes.

8 Diagrams

Figure 8-8 Ladder Diagram - 240V, 1 Phase

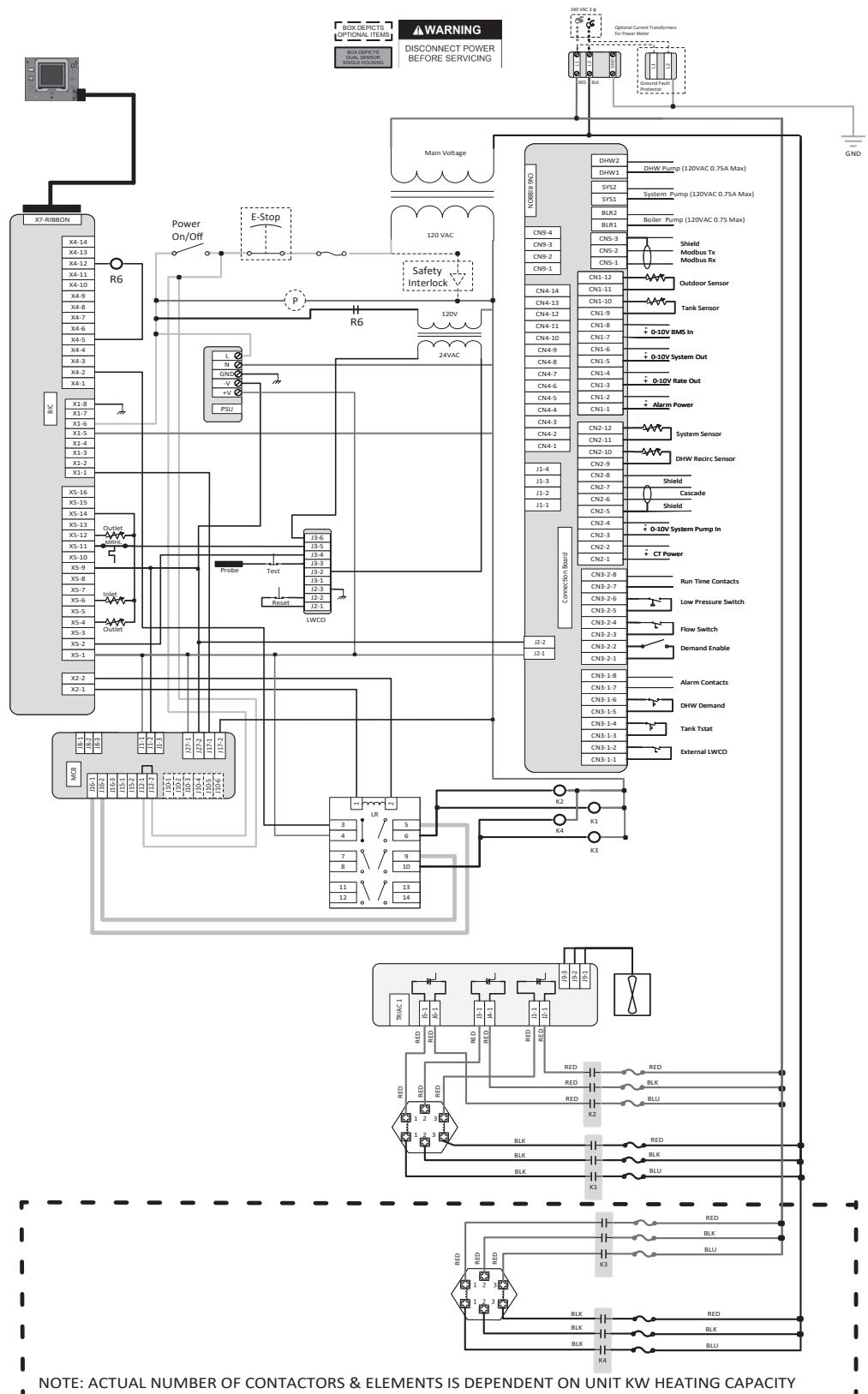

Notes:

1. Where possible, switches are shown without utilities (water or electricity) connected to the unit. As such, actual switch states may vary from those shown on diagrams depending upon whether utilities are connected, or a fault condition is present.
2. See wiring diagram for additional notes.

8 Diagrams *(continued)*

Figure 8-9 Ladder Diagram - 400-600V, 3 Phase

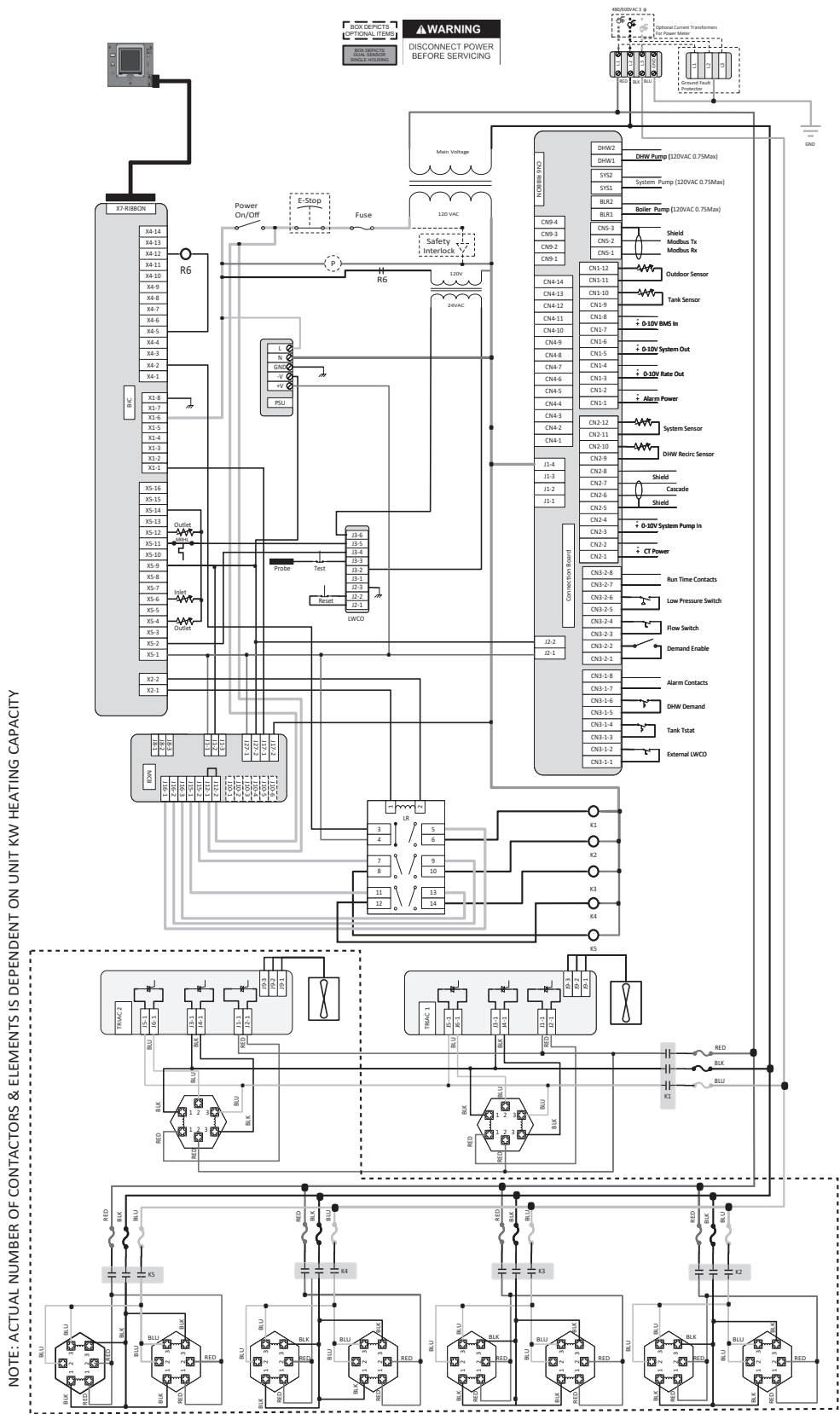

Notes:

1. Where possible, switches are shown without utilities (water or electricity) connected to the unit. As such, actual switch states may vary from those shown on diagrams depending upon whether utilities are connected, or a fault condition is present.
2. See wiring diagram for additional notes.

NOTE: ACTUAL NUMBER OF CONTACTORS & ELEMENTS IS DEPENDENT ON UNIT KW HEATING CAPACITY

NOTES

NOTES

NOTES

Revision Notes: *Revision A (PCP #3000058503 / CN #500044576) initial release.*

Revision B (PCP #3000059588 / CN #500045650) reflects updated images throughout.

Revision C (PCP #3000061190 / CN #500047088) reflects updates to table 4A.

Revision D (PCP #3000061447 / CN #500047320) reflects updates on page 4 and figure 6-2.

Revision E (PCP #3000063264 / CN #500049042) reflects updates to figure 3-4.

Revision F (3000063785 / CN #500049627) reflects changes throughout, including updated diagrams.