

# LECTRUS™

## Service Manual

Models: KEB0015 - KEB0150

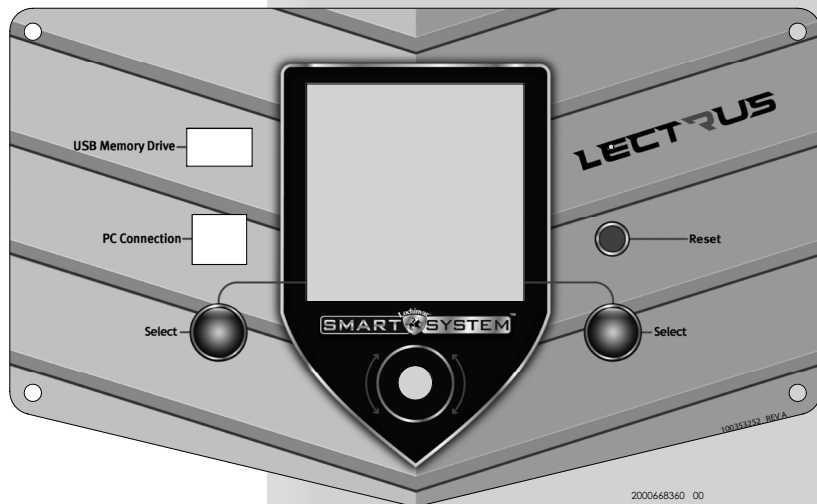

2000668360 00

**⚠ WARNING**

This manual must only be used by a qualified heating installer / service technician. Read all instructions, including this manual and the Lectrus Installation and Operation Manual, before installing. Perform steps in the order given. Failure to comply could result in severe personal injury, death, or substantial property damage.

**Save this manual for future reference.**



# Lochinvar®





HIGH EFFICIENCY BOILERS & WATER HEATERS

# Contents

<b>CONTENTS</b> .....	2	<b>2. MAINTENANCE</b>	
Hazard Definitions.....	2	Maintenance and Annual Startup.....	31-39
<b>PLEASE READ BEFORE PROCEEDING</b> .....	3	<b>3. TROUBLESHOOTING</b>	
When servicing boiler.....	3	Before Troubleshooting.....	37
Boiler operation.....	3	Check Control Module Fuses.....	37
Boiler water.....	3	Table 3-2 - Troubleshooting Chart - No Display.....	38
Freeze protection fluids.....	3	Checking Temperature Sensors.....	39
WHAT IS IN THIS MANUAL.....	4	Table 3-4 - Troubleshooting Chart - Noisy System.....	40
<b>1. SERVICE</b>		Table 3-5 - Troubleshooting Chart - Fault Messages.....	41-44
Near Boiler Piping.....	5	Table 3-6 - Troubleshooting Chart - MCB.....	45-46
The Lectrus Display.....	6	Revision Notes.....	Back Cover
Control Inputs.....	7		
Control Outputs.....	8		
General Operation.....	9		
Sequence of Operation.....	10-11		
Display Panel Menu Access.....	12		
Display Panel Parameter Access.....	13-14		
Parameter Table.....	15-18		
Viewable and Changeable Control Parameters.....	19-32		

## Hazard definitions

The following defined terms are used throughout this manual to bring attention to the presence of hazards of various risk levels or to important information concerning the life of the product.

-  **DANGER** DANGER indicates an imminently hazardous situation which, if not avoided, will result in death or serious injury.
-  **WARNING** WARNING indicates a potentially hazardous situation which, if not avoided, could result in death or serious injury.
-  **CAUTION** CAUTION indicates a potentially hazardous situation which, if not avoided, may result in minor or moderate injury.
-  **CAUTION** CAUTION used without the safety alert symbol indicates a potentially hazardous situation which, if not avoided, may result in property damage.
-  **NOTICE** NOTICE indicates special instructions on installation, operation, or maintenance that are important but not related to personal injury or property damage.

## Please read before proceeding

**WARNING**

**Installer** – Read all instructions, including this manual and the Lectrus Installation and Operation Manual, before installing. Perform steps in the order given.

**User** – This manual is for use only by a qualified heating installer/service technician. Refer to the Lectrus User's Information Manual for your reference.

Have this boiler serviced/inspected by a qualified service technician at least annually.

Failure to comply with the above could result in severe personal injury, death, or substantial property damage.

**NOTICE**

When calling or writing about the boiler – Please have the boiler model and serial number from the boiler rating plate.

Consider piping and installation when determining boiler location (see the Lectrus Installation and Operation Manual).

Any claims for damage or shortage in shipment must be filed immediately against the transportation company by the consignee.

### When servicing boiler –

- To avoid electric shock, disconnect electrical supply before performing maintenance.
- To avoid severe burns, allow boiler to cool before performing maintenance.

### Boiler operation –

- Do not block flow of ventilation air to the boiler.
- Should overheating occur or failure to shut off, do not turn off or disconnect electrical supply to circulator.
- Do not use this boiler if any part has been under water. The possible damage to a flooded appliance can be extensive and present numerous safety hazards. Any appliance that has been under water must be replaced.

### Boiler water –

- Thoroughly flush the system (without boiler connected) to remove sediment. The pressure vessel can be damaged by build-up or corrosion due to sediment.
- Do not use petroleum-based cleaning or sealing compounds in the boiler system. Gaskets and seals in the system may be damaged. This can result in substantial property damage.
- Do not use “homemade cures” or “boiler patent medicines”. Serious damage to the boiler, personnel, and/or property may result.
- Continual fresh make-up water will reduce boiler life. Mineral buildup in the pressure vessel causes failure. Addition of oxygen carried in by makeup water can cause internal corrosion. Leaks in boiler piping must be repaired at once to prevent the introduction of makeup water.

### Freeze protection fluids –

- NEVER use automotive antifreeze. Use only inhibited propylene glycol solutions which are specifically formulated for hydronic systems. Ethylene glycol is toxic and can attack gaskets and seals used in hydronic systems.

## What is in this manual?

### Service

#### Near boiler piping

- Typical system components

#### The Lectrus display

- Display panel readout, buttons, and their functions

#### Control module inputs

- Control module inputs and options

#### Control module outputs

- Control module outputs and options

### General

- How the boiler operates
- How the control module operates
- Access modes -- user and installer
- Sequence of operation -- Domestic Hot Water (DHW)/space heating

#### Control panel menu access

- Accessing programming mode and locating menus (See separate guide covering the interface.)

#### Control panel parameter access

- Accessing and changing parameters from the display panel

#### Quick start information -- parameter table

- An index of available adjustments and readouts, where to access them and where to find detailed information.

### Lectrus parameters

- General
- Temperature Setting
- Data Logging
- Functions
- DHW Settings
- Outdoor Reset
- Anti-cycling
- Control Modes
- Building Management System (BMS)
- Circulation Pumps
- Service Notification
- Basic Setup
- USB
- Setup Wizard

### Maintenance

- Service and maintenance schedules
- Address reported problems
- Inspect boiler area and boiler interior
- Check all piping for leaks
- Check water system
- Check expansion tank
- Check boiler relief valve
- Check all boiler wiring
- Check control settings
- Perform start-up and checks
- General maintenance
- Review with owner
- Cleaning boiler
- Oiled bearing circulators

### Troubleshooting

- Troubleshooting table - No display
- Checking temperature sensors
- Sensor tables
- Troubleshooting table - Fault messages displayed on boiler interface

# 1 Service

## Near boiler piping

This piping reference is included to specify the *Near Boiler Piping* specific to the Lectrus. This piping scheme is important for proper operation of the SMART SYSTEM control. See the Lectrus Installation and Operation Manual for more detailed piping diagrams.

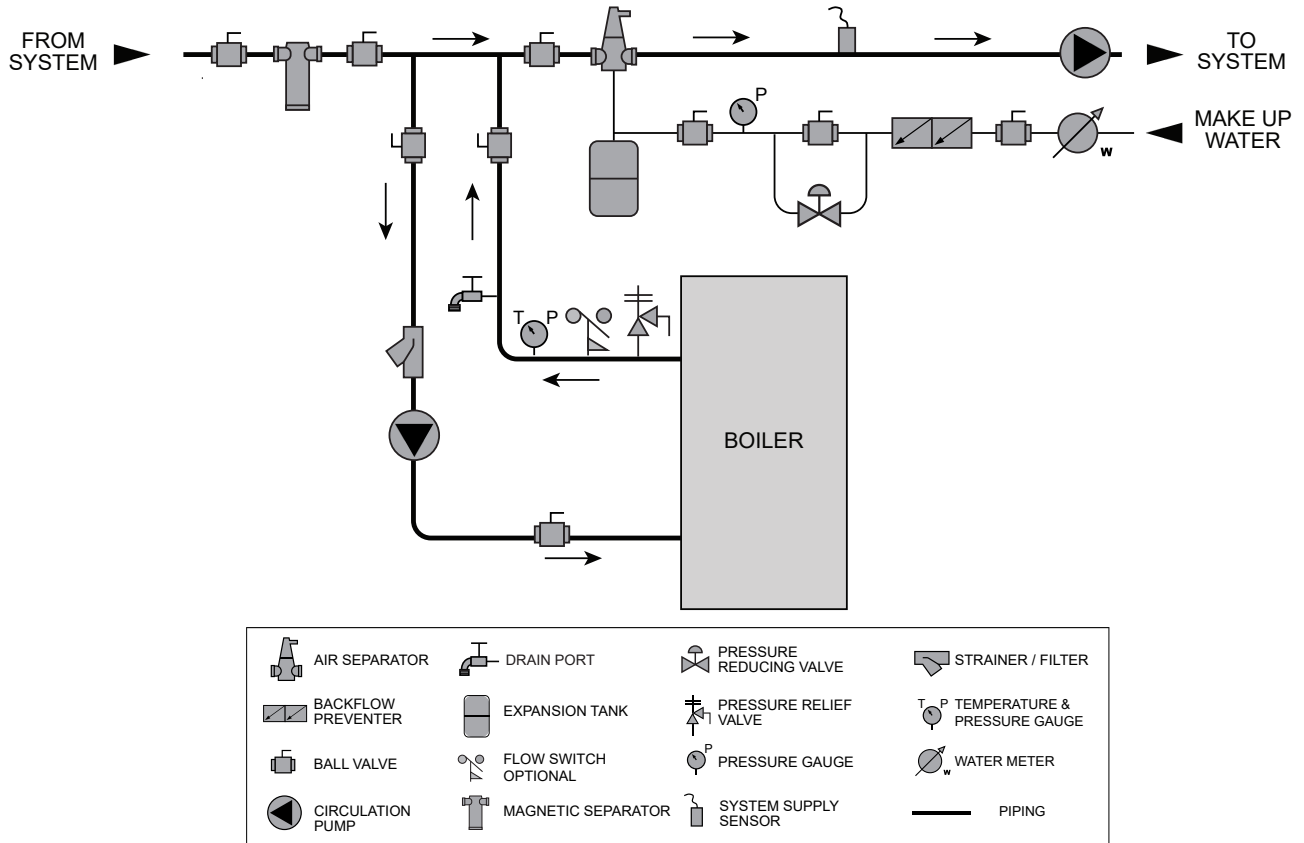

DIR #2000546697 01

# 1 Service *(continued)*

## The Lectrus display

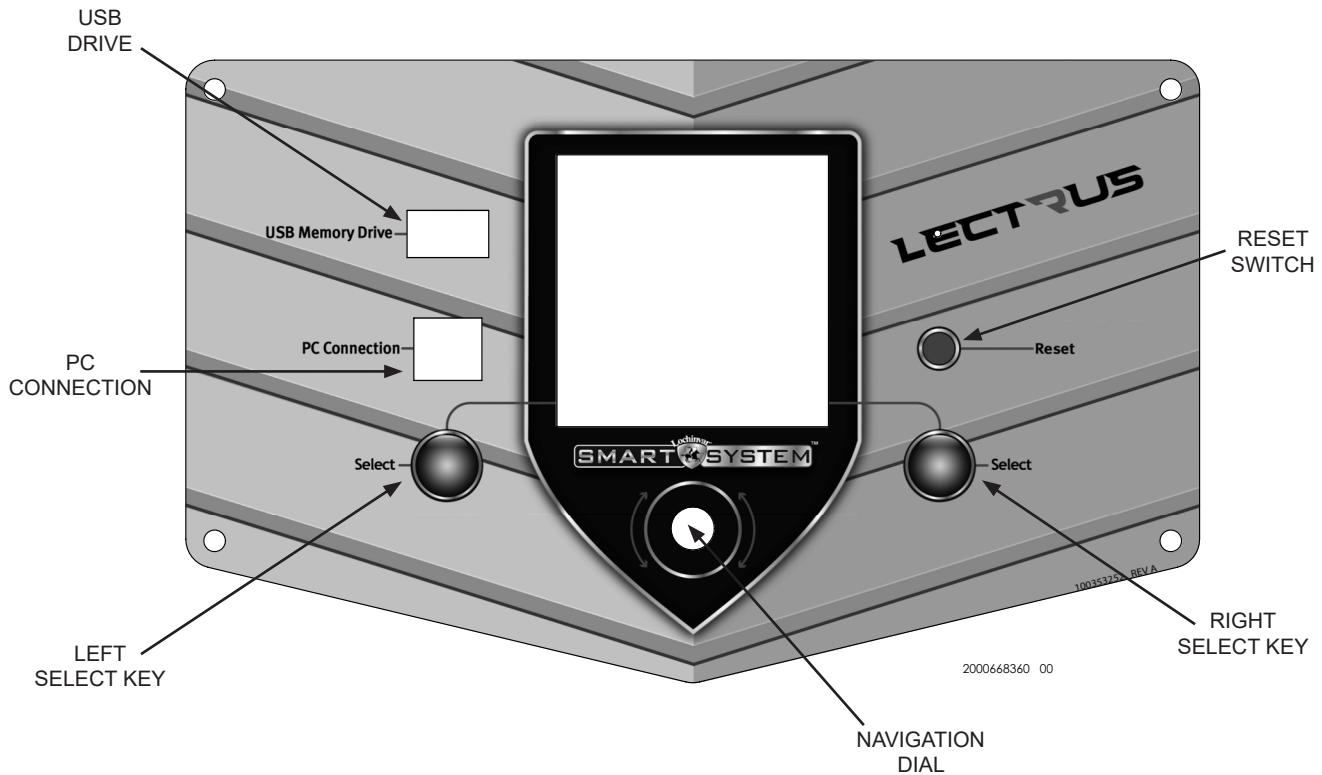

The information on the bottom of the display shows the functions of the two SELECT keys (on either corner), and the NAVIGATION dial (in the center):

MENU = Left SELECT Key

SHDN = Right SELECT Key

# 1 Service

## Control inputs

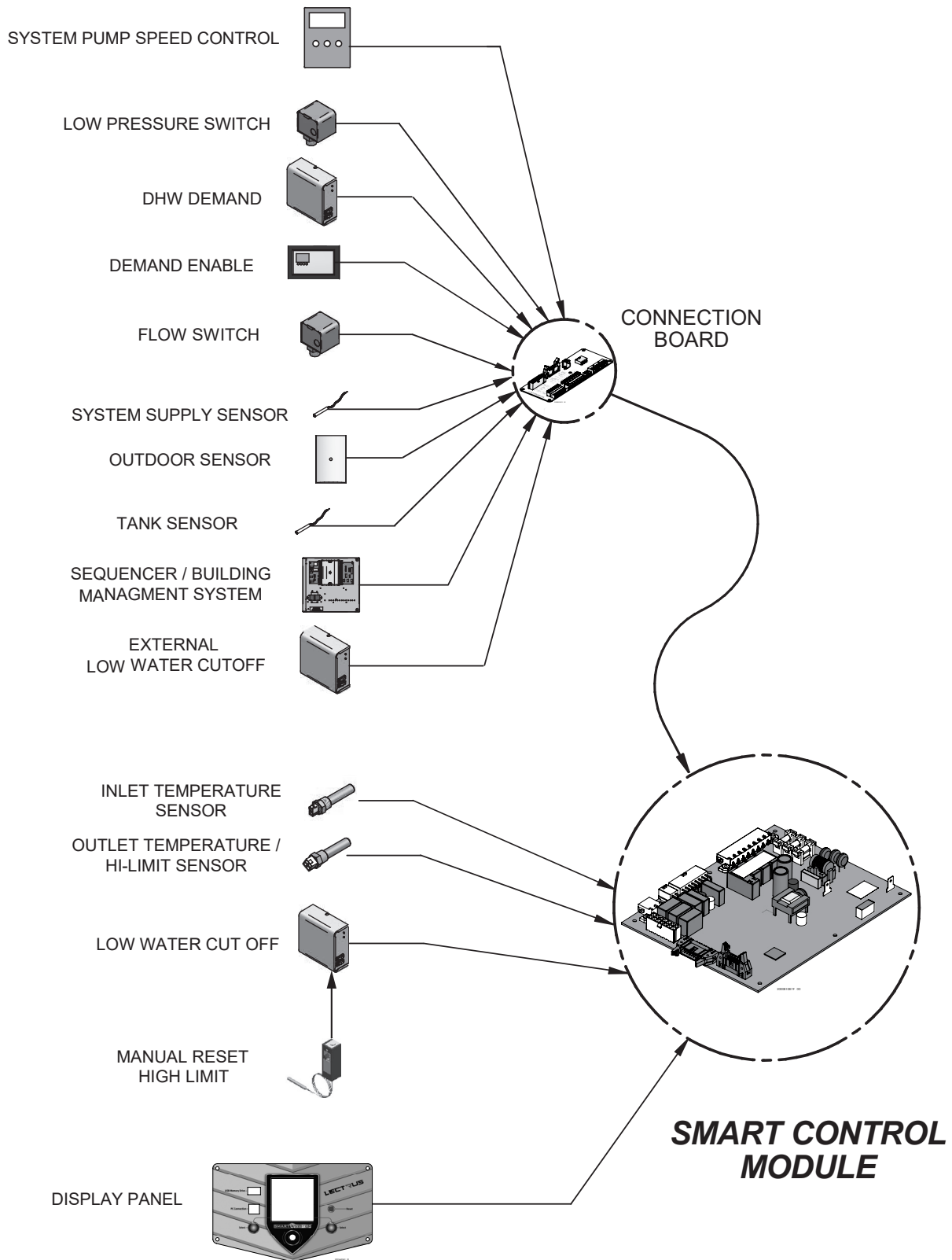

IMG00006

# 1 Service *(continued)*

## Control outputs

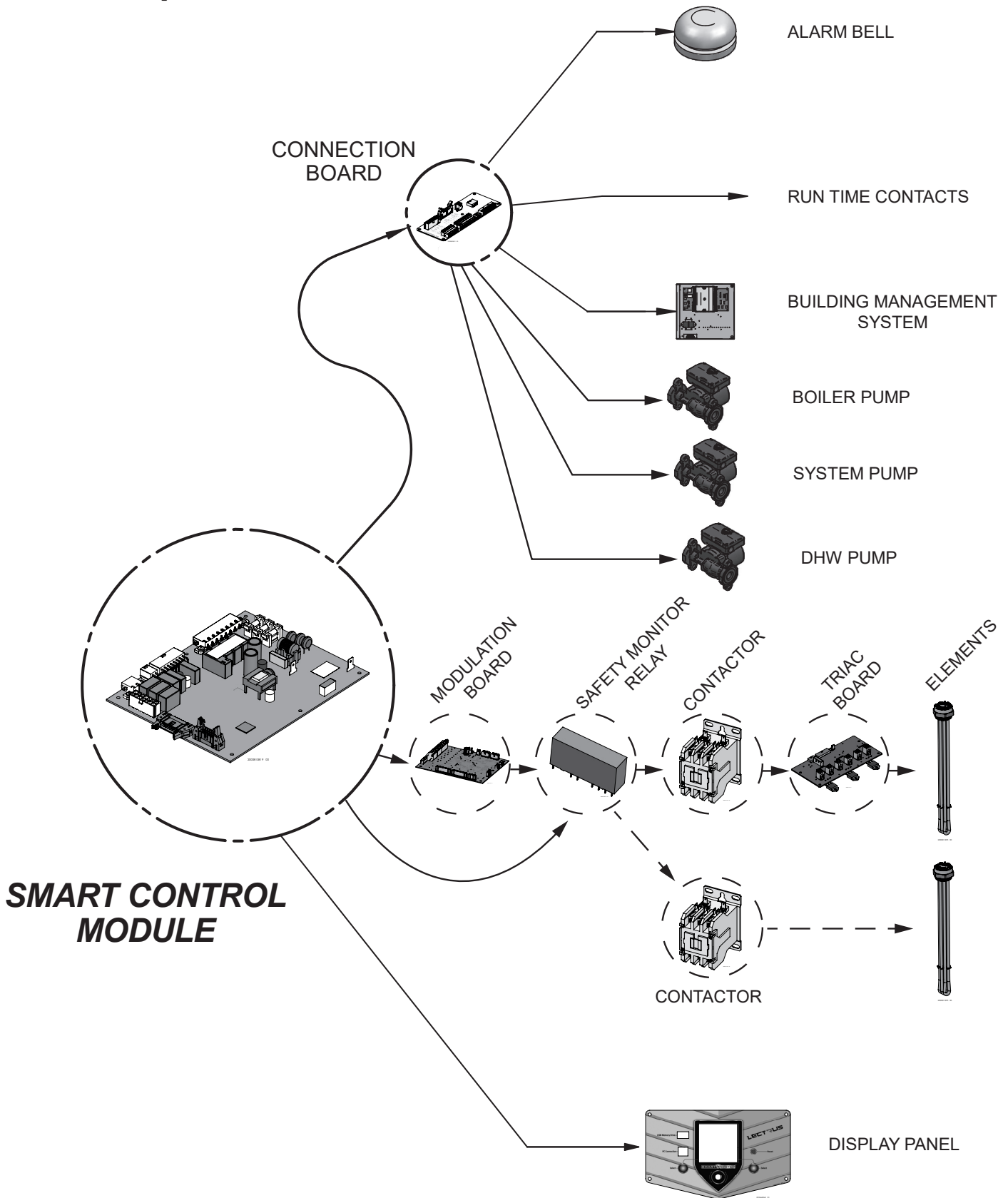

# 1 Service

## General Operation

### How the boiler operates

The Lectrus uses an electronic control modules to fully control the heating elements that transmit heat to water. Upon a call for heat, the SMART SYSTEM will evaluate the amount of power needed, and share this with the modulation control that will drive the contactor and triac to provide power to the elements.

### How the control module operates

The Lectrus control module receives input from boiler sensors. The controls regulate heat input and switches boiler, DHW, and system pumps on and off as needed. The user/installer programs the module to meet system needs by adjusting control parameters. These parameters set operating temperatures and boiler operating modes. Boiler operation can be based on boiler outlet water temperature, boiler return water temperature or system supply temperature, depending on the parameter setting.

### Sequence of operation

Table 1-1 shows control module normal sequences of operation for space heating and DHW operation. The combined operation sequence is for a typical application, programmed to provide DHW priority.

### Low Water Cut Off (LWCO)

The Lectrus LWCO protects the pressure vessel from overheating, by ensuring adequate water is supplied to the boiler. In the event of inadequate water levels, the boiler will shut down.

### LWCO test procedure

Ensure the system has been filled, leak tested, and purged of all air that may have become entrapped when the LWCO probe was installed. Periodic testing of the LWCO is recommended.

### LWCO test for manual reset

1. Once the unit enters a Heating cycle, press and hold the black Test switch at the back of the appliance for a minimum of 10 seconds.
2. The test switch permits manual triggering of the LWCO safety circuit to test the contacts and evaluate the integrity of the circuit. Hold the switch for 10 seconds to test.
3. Wait 20 seconds to ensure the unit goes into LWCO lockout.
4. Once it is determined that the unit is in LWCO lockout, you must first reset the display and then depress the red Reset switch next to the black Test switch at the back of the appliance.
5. If LWCO is working properly, the unit will start heating again.

## Access modes

### User

The user can adjust the date and time, enable/disable vacation mode, select the temperature units, and change the display contrast.

### Installer

Most parameters are available only to the installer, accessible by entering the installer password (5309).

### Setup Wizard

The Lectrus control has a Setup Wizard feature that is automatically accessed the first time the unit is powered. This feature allows setting of commonly required parameters without the need to enter the installer password. Once the Setup Wizard is completed or canceled, it can only be accessed through the installer menu.

**Saving parameters** (reference the Parameter Table - Table 1-4 on pages 16-19 of this manual)

**NOTICE**

Please note that the brackets ([ ]) denote screen status.

### To save parameters and exit programming:

Press the RIGHT SELECT [SAVE] key and then press the RIGHT SELECT [HOME] key.

### To enter a parameter and continue programming:

Press the RIGHT SELECT [SAVE] key 1 time to return to the parameter listings; press again to return to the menu listings. Remember to press the RIGHT SELECT [HOME] key when finished programming in order to save the changes made.

# 1 Service *(continued)*

**Table 1-1 Sequence of Operation**

OPERATION	DISPLAY
1. Standby.	<p style="text-align: center;"><b>STANDBY</b></p> <p>BANK ENABLE MCB 1  <input type="checkbox"/> <input type="checkbox"/></p> <p>INLET: 48°F            OUTLET: 89°F            DELTA T: 41°F            TANK: NONE (120)</p> <hr/> <p>MENU    ↓NEXT    SHDN</p>
2. Upon a call for space heat.	<p style="text-align: center;"><b>WATER CHECK</b></p> <p>BANK ENABLE MCB 1  <input type="checkbox"/> <input type="checkbox"/></p> <p>INLET: 48°F            OUTLET: 89°F (85)            DELTA T: 40°F            TANK: NONE (120)</p> <hr/> <p>MENU    ↻SCREEN    SHDN</p>
3. The controls turn on the appropriate pumps, the flow switch and LWCO must close.	<p style="text-align: center;"><b>WATER CHECK</b></p> <p>BANK ENABLE MCB 1  <input type="checkbox"/> <input type="checkbox"/></p> <p>CH PUMP                    ON            HW PUMP                   OFF            SYS PUMP                   ON</p> <hr/> <p>MENU    ↓NEXT    SHDN</p>
4. The unit goes in "WATER CHECK" mode.	<p style="text-align: center;"><b>WATER CHECK</b></p> <p>BANK ENABLE MCB 1  <input type="checkbox"/> <input type="checkbox"/></p> <p>INLET: 48°F            OUTLET: 89°F (85)            DELTA T: 40°F            TANK: NONE (120)</p> <hr/> <p>MENU    ↻SCREEN    SHDN</p>
5. The unit goes in "STARTUP" mode.	<p style="text-align: center;"><b>STARTUP</b></p> <p>BANK ENABLE MCB 1  <input type="checkbox"/> <input type="checkbox"/></p> <p>INLET: 48°F            OUTLET: 88°F (110)            DELTA T: 40°F            TANK: NONE (120)</p> <hr/> <p>MENU    ↻SCREEN    SHDN</p>

# 1 Service

**Table 1-1** (continued from previous page) *Sequence of Operation*

OPERATION	DISPLAY
6. The unit goes in "RUN" mode.	<pre> <b>RUN</b>      TARGET 9 %               REAL  5 %  BANK_ENABLE MCB 1 <input checked="" type="checkbox"/> <input type="checkbox"/> INLET:      48°F OUTLET:     88°F&lt;(110) DELTA T:    40°F TANK:       NONE &lt;(120)  ----- MENU  ↓NEXT  SHDN </pre>
7. If the space heating call is active, and the tank thermostat or sensor starts a DHW call for heat, the boiler will switch to the DHW mode. If programmed for normal DHW operation (not as zone) the DHW pump will turn ON first, then the boiler pump will turn OFF (boiler and DHW pump operation briefly overlap to ensure flow is maintained through the unit). This will divert the boiler's outlet water from the heating system and send it to the tank coil instead. The control will then modulate to maintain the outlet temperature to the DHW boiler setpoint.	<pre> <b>RUN</b>      TARGET 100 %               REAL  100 %  BANK_ENABLE MCB 1 <input checked="" type="checkbox"/> <input checked="" type="checkbox"/> CH PUMP                ON HW PUMP                ON SYS PUMP              ON  ----- MENU  ↻SCREEN  SHDN </pre>
8. If the boiler is not part of a cascade, and both the space heating and DHW calls for heat remain active long enough, the boiler will switch back and forth between the two modes until one of them is satisfied.	<pre> <b>RUN</b>      TARGET 100 %               REAL  100 %  BANK_ENABLE MCB 1 <input checked="" type="checkbox"/> <input checked="" type="checkbox"/> CH PUMP                OFF HW PUMP                ON SYS PUMP              ON  ----- MENU  ↓NEXT  SHDN </pre>
9. Once both calls for heat are satisfied, the control will turn off.	<pre> <b>Setpoint MET</b>  ANTI-CYCLING BANK_ENABLE MCB 1 <input type="checkbox"/> <input type="checkbox"/> INLET:      48°F OUTLET:     111°F&lt;(110) DELTA T:    62°F TANK:       NONE &lt;(120)  ----- MENU  ↻SCREEN  SHDN </pre>
10. First the unit will slowly turn OFF the elements in order ending with the triacs.	<pre> <b>Setpoint MET</b>  ANTI-CYCLING BANK_ENABLE MCB 1 <input type="checkbox"/> <input type="checkbox"/> INLET:      48°F OUTLET:     111°F&lt;(110) DELTA T:    62°F TANK:       NONE &lt;(120)  ----- MENU  ↻SCREEN  SHDN </pre>

# 1 Service







**Table 1-1** (continued from previous page) *Sequence of Operation*

OPERATION	DISPLAY
<p>11. Then the unit will go into an Anti-cycling mode to prevent it from being re-enabled too fast.</p>	<pre> Setpoint MET ANTI-CYCLING BANK_ENABLE MCB 1 □ □ INLET:           48°F OUTLET:          111°F&lt;110&gt; DELTA T:         62°F TANK:            NONE &lt;120&gt;  ----- MENU  ↵SCREEN  SHDN           </pre>
<p>12. Any pumps that are running will continue to run for their respective pump delay times before turning OFF unless programmed to remain continuously ON.</p>	<pre> STANDBY  BANK_ENABLE MCB 1 □ □ CH_PUMP           OFF HW_PUMP           OFF SYS_PUMP          OFF  ----- MENU  ↵NEXT   SHDN           </pre>
<p>13. The unit is now back into Standby and ready for a new cycle.</p>	<pre> STANDBY  BANK_ENABLE MCB 1 □ □ INLET:           48°F OUTLET:          89°F DELTA T:         41°F TANK:            NONE &lt;120&gt;  ----- MENU  ↵NEXT   SHDN           </pre>

# 1 Service *(continued)*

## Display panel menu access





**Table 1-2** Use this procedure to access menus from the display panel

BUTTON	SCREEN STATUS	OPERATION	DISPLAY
	[MENU]	Press and hold the LEFT SELECT soft key [MENU] for five (5) seconds.	<p><b>STANDBY</b></p> <p>BANK ENABLE MCB 1  <input type="checkbox"/> <input type="checkbox"/>            INLET: 48°F            OUTLET: 89°F            DELTA T: 41°F            TANK: NONE (120)</p> <hr/> MENU    ↓NEXT    SHDN
		Rotate the NAVIGATION dial clockwise until 5 is displayed (first digit on the left).	<p><b>STANDBY</b></p> <p>BANK ENABLE MCB 1  <input type="checkbox"/> <input type="checkbox"/>            PASSWORD            5000</p> <hr/> EXIT    ↓NEXT    SAVE
		Press the NAVIGATION dial to select the next digit. Rotate the NAVIGATION dial clockwise until 3 is shown in the display.	<p><b>STANDBY</b></p> <p>BANK ENABLE MCB 1  <input type="checkbox"/> <input type="checkbox"/>            PASSWORD            5300</p> <hr/> EXIT    ↻ADJUST    SAVE
		Press the NAVIGATION dial 2 times to move to the last digit. Rotate the NAVIGATION dial counterclockwise until 9 is displayed.	<p><b>STANDBY</b></p> <p>BANK ENABLE MCB 1  <input type="checkbox"/> <input type="checkbox"/>            PASSWORD            5309</p> <hr/> EXIT    ↓NEXT    SAVE
		If the passcode shown is not "5309" press the navigation dial to the incorrect number and rotate the navigation dial until the correct digit is selected.	<p><b>STANDBY</b></p> <p>BANK ENABLE MCB 1  <input type="checkbox"/> <input type="checkbox"/>            PASSWORD            5309</p> <hr/> EXIT    ↓NEXT    SAVE
	[SAVE]	Press the RIGHT SELECT soft key [SAVE].	<p><b>STANDBY</b></p> <p>BANK ENABLE MCB 1  <input type="checkbox"/> <input type="checkbox"/>            &gt;GENERAL            TEMPERATURE SETTINGS            DATA LOGGING            FUNCTIONS            DAW SETTINGS            ANTI-CYCLING            CONTROL MODES</p> <hr/> HOME    ↻SCROLL

# 1 Service

## Display panel parameter access



**Table 1-3** This is a typical example of accessing a parameter, shown for parameter Temperature Settings, MIN SH Setpt

BUTTON	SCREEN STATUS	OPERATION	DISPLAY
<p><i>This example shows how to access parameter Temperature Settings. The first display shown is at the beginning of the menu listings, after entering the installer access code.</i></p>			
		Rotate the NAVIGATION dial counterclockwise until the arrow (>) is next to <b>TEMPERATURE SETTINGS</b> .	<b>STANDBY</b>  BANK ENABLE MCB 1 <input type="checkbox"/> <input type="checkbox"/> GENERAL >TEMPERATURE SETTINGS DATA LOGGING FUNCTIONS DHW SETTINGS ANTI-CYCLING CONTROL MODES <hr/> HOME ↵SCROLL
		Press the NAVIGATION dial one time.	<b>STANDBY</b>  BANK ENABLE MCB 1 <input type="checkbox"/> <input type="checkbox"/> SH1 SETPT: 110°F >MIN SH SETPT: 60°F MAX SH SETPT: 215°F SH1 OFFSET: 2°F SH1 DIFF: 4°F INLET SETPT: 104°F INLET OFFSET: 10°F <hr/> EXIT ↵SELECT HOME
		Rotate the NAVIGATION dial counterclockwise until the arrow (>) is next to <b>MIN SETPT</b> .	<b>STANDBY</b>  BANK ENABLE MCB 1 <input type="checkbox"/> <input type="checkbox"/> SH1 SETPT: 110°F >MIN SH SETPT: 60°F MAX SH SETPT: 215°F SH1 OFFSET: 2°F SH1 DIFF: 4°F INLET SETPT: 104°F INLET OFFSET: 10°F <hr/> EXIT ↵SELECT HOME
		Press the NAVIGATION dial one time.	<b>STANDBY</b>  BANK ENABLE MCB 1 <input type="checkbox"/> <input type="checkbox"/> SH1 SETPT: 110°F >MIN SH SETPT: 60°F MAX SH SETPT: 215°F SH1 OFFSET: 2°F SH1 DIFF: 4°F INLET SETPT: 104°F INLET OFFSET: 10°F <hr/> EXIT ↵SELECT HOME
		Rotate the NAVIGATION dial to the desired temperature.	<b>STANDBY</b>  BANK ENABLE MCB 1 <input type="checkbox"/> <input type="checkbox"/> SH1 SETPT: 110°F >MIN SH SETPT: 60°F MAX SH SETPT: 215°F SH1 OFFSET: 2°F SH1 DIFF: 4°F INLET SETPT: 104°F INLET OFFSET: 10°F <hr/> EXIT ↵ADJUST SAVE

# 1 Service *(continued)*

## Display panel parameter access (cont.)

**Table 1-3** This is a typical example of accessing a parameter, shown for parameter Temperature Settings, MIN SH Setpt

BUTTON	SCREEN STATUS	OPERATION	DISPLAY
<p><i>This example shows how to access parameter Temperature Settings. The first display shown is at the beginning of the menu listings, after entering the installer access code.</i></p>			
	[SAVE]	Press the RIGHT SELECT soft key [SAVE] one time.	<pre> STANDBY  BANK ENABLE MCB 1 <input type="checkbox"/> <input type="checkbox"/> SH1 SETPT:      110°F &gt;MIN SH SETPT:  65°F MAX SH SETPT:   215°F SH1 OFFSET:     2°F SH1 DIFF:       4°F INLET SETPT:    104°F INLET OFFSET:   10°F ----- EXIT  ↵ADJUST  SAVE           </pre>
	[EXIT]	Press the LEFT SELECT soft key [EXIT] if all desired changes have been made.	<pre> STANDBY  BANK ENABLE MCB 1 <input type="checkbox"/> <input type="checkbox"/> SH1 SETPT:      110°F &gt;MIN SH SETPT:  65°F MAX SH SETPT:   215°F SH1 OFFSET:     2°F SH1 DIFF:       4°F INLET SETPT:    104°F INLET OFFSET:   10°F ----- EXIT  ↵SELECT  HOME           </pre>
	[HOME]	Press the LEFT SELECT soft key [HOME].	<pre> STANDBY  BANK ENABLE MCB 1 <input type="checkbox"/> <input type="checkbox"/> GENERAL &gt;TEMPERATURE SETTINGS DATA LOGGING FUNCTIONS DHW SETTINGS ANTI-CYCLING CONTROL MODES ----- HOME  ↵SELECT           </pre>
<p>Wait for the new settings to be saved.</p>			<pre> LOADING DATA...  Uploading Parameters.. Please wait  -----           </pre>

# 1 Service

## Parameter table

Table 1-4 This table lists SMART SYSTEM control module parameters and where to access them

Menu	Description	See Page	User Access	Installer Access
GENERAL	Vacation mode	20	Yes	Yes
	Time & Date	20	Yes	Yes
	Software version	20 20	No	Yes
	Temperature unit	22	Yes	Yes
	Space heat night setback offset IF Space heat night setback > 0: i. Space heat night setback On times ii. Space heat night setback Off times	20	No	Yes
	DHW night setback offset IF DHW night setback > 0: i. DHW night setback On times ii. DHW night setback Off times	20	No	Yes
	Display Timeout	21	No	Yes
	Display Contrast	21	Yes	Yes
TEMPERATURE SETTINGS	Space heat setpoint	21	No	Yes
	Minimum space heat setpoint	21	No	Yes
	Maximum space heat setpoint	21	No	Yes
	Space heat offset	21	No	Yes
	Space heat differential	21	No	Yes
	Auto reset high limit	21	No	Yes
	Manual reset high limit	22	No	Yes
DATA LOGGING	Reset Log Errors	22	No	Yes
FUNCTIONS	Service mode delay	22	No	Yes
	Freeze detection pump ON	22	No	Yes
	Freeze detection power ON	22	No	Yes
	Freeze detection differential	22	No	Yes
DHW SETTINGS	Tank Setpoint	22	No	Yes
	Tank Setpoint differential	22	No	Yes
	DHW boiler setpoint	22	No	Yes
	DHW boiler offset	22	No	Yes
	DHW boiler differential	22	No	Yes
	Tank Minimum setpoint	23	No	Yes
	Tank maximum setpoint	23	No	Yes
	DHW Max power	23	No	Yes
	DHW type (normal, zone) i. Space heat/DHW switching time ii. DHW/Space heat switching time ELSE: i. DHW FORCES SYSP (YES/NO) ii. DHW BLOCKS SYSP (YES/NO)	23	No	Yes
	Space heat to DHW switching time	23	No	Yes
DHW to space heat switching time	23	No	Yes	

# 1 Service *(continued)*

## Parameter table

**Table 1-4** (continued from previous page) This table lists SMART SYSTEM control module parameters and where to access them

Menu	Description	See Page	User Access	Installer Access
<b>OUTDOOR RESET</b> (ifn sensor installed)	Outdoor Low	23	No	Yes
	Outdoor high	23	No	Yes
	Setpoint at low output	24	No	Yes
	Setpoint at high output	24	No	Yes
	Outdoor shutdown	24	No	Yes
	Outdoor differential	24	No	Yes
	Outdoor shift	24	No	Yes
	Boost temp	25	No	Yes
	Boost time (if boost temp is not 0)	25	No	Yes
<b>ANTI-CYCLING</b>	Anti-cycling time	25	No	Yes
	Anti-cycling override differential	25	No	Yes
	Ramp Delay (Enable/Disable)	25	No	Yes
	Modulation Factor	25	No	Yes
<b>CONTROL MODE</b>	Control sensor	26	No	Yes
	Cascade Address IF Address = 0: Max Cascade Setpoint Cascade Offset Cascade Differential Cascade Type (L/L, EFF) Minimum On/Off Time Minimum Next On Time Minimum Pumps On IF Address = 1: Alternate Leader? (Y/N) IF Yes: Max Cascade Setpoint Cascade Offset Cascade Differential Cascade Type (L/L, EFF) Minimum On/Off Time Minimum Next On Time Minimum Pumps On	26	No	Yes
	Boiler size i. Cascade address ii. Type iii. Input size	27	No	Yes
	Building Management System BMS (Active, Inactive) 1. BMS Type (Power, Set Point) IF Power: 1. Rate at minimum voltage 2. Rate at maximum voltage 3. Volts for minimum rate 4. Volts for maximum rate 5. BMS thermostat (active/inactive) IF inactive i. ON volts ii. OFF diff volts	28	No	Yes

# 1 Service

## Parameter table

Table 1-4 (continued from previous page) This table lists SMART SYSTEM control module parameters and where to access them

Menu	Description	See Page	User Access	Installer Access
<b>CONTROL MODE CONT.</b>	IF Set point: 1. Set point at minimum voltage 2. Set point at maximum voltage 3. Volts for minimum set point 4. Volts for maximum set point 5. BMS thermostat (active/inactive) IF inactive i. ON volts ii. OFF diff volts	28	No	Yes
	Modbus/BACnet	28	No	Yes
	BAS Timeout	29	No	Yes
<b>CIRCULATION PUMP</b>	System pump delay	29	No	Yes
	Boiler pump delay	29	No	Yes
	DHW pump delay	29	No	Yes
	System pump anti-seize	29	No	Yes
	Boiler pump anti-seize	29	No	Yes
	DHW anti-seize	29	No	Yes
	System pump type	29	No	Yes
	Boiler pump delta T	29	No	Yes
	Boiler pump minimum voltage	29	No	Yes
	Boiler pump maximum voltage	29	No	Yes
	Boiler pump standby voltage	29	No	Yes
	Boiler pump type	29	No	Yes
<b>SERVICE NOTIFICATION</b>	Service notification month	30	No	Yes
	Service notification run time	30	No	Yes
	Service notification cycle count	30	No	Yes
	Reset service reminder	30	No	Yes
	Yes or No	30	No	Yes
	Service name	30	No	Yes
	Service Phone	30	No	Yes

# 1 Service *(continued)*

## Parameter table

**Table 1-4** (continued from previous page) This table lists SMART SYSTEM control module parameters and where to access them

Menu	Description	See Page	User Access	Installer Access
<b>BASIC SETUP</b>	Time & date	20	No	Yes
	Cascade address IF Address = 0: i. Maximum Cascade Set Point ii. Cascade Offset iii. Cascade Differential iv. Cascade Type (L/L, EFF)	26	No	Yes
	Differential to disable the boiler IF Outdoor Sensor Connected: i. Low Outdoor Temperature 1 ii. High Outdoor Temperature 1 iii. SH1 Set Point at Low Outdoor Temperature iv. SH1 Set Point at High Outdoor Temperature v. Outdoor Shutdown Temperature vi. Outdoor Shutdown Differential 1	28	No	Yes
	Building Management system BMS (Active, Inactive) IF Active: 1. BMS Type (Power, Set Point) IF Power: 1. Rate at minimum voltage 2. Rate at maximum voltage 3. Volts for minimum rate 4. Volts for maximum rate 5. BMS thermostat (active/inactive) IF inactive i. ON volts ii. OFF diff volts IF Set point: 1. Set point at minimum voltage 2. Set point at maximum voltage 3. Volts for minimum set point 4. Volts for maximum set point 5. BMS thermostat (active/inactive) IF inactive i. ON volts ii. OFF diff volts	28	No	Yes
<b>USB</b>	Loch-N-Link	30	No	Yes
<b>SETUP WIZARD</b>		9	No	Yes

# 1 Service

## Viewable and changeable control parameters

### CAUTION

Before changing parameters, note the settings so that the unit can be returned to its original operating parameters.

### General

#### Vacation Mode

This parameter forces the Space Heating (SH) and DHW set points to decrease by the amounts programmed in the Night Setback Offset parameters. It is used to save energy, such as when the building is unoccupied for an extended period of time. For this function to work, the *Space Heating Night Setback Offset* and/or *DHW Night Setback Offset parameters* must be set to a value higher than 0°. The default value of this parameter is OFF.

#### Time and Date

The control uses an internal clock for the night setback feature and for logging of events. For these features to work correctly, the clock must be set when the boiler is first installed or anytime the boiler has been powered off for more than four (4) hours. This parameter must be accessed to set the clock.

### NOTICE

The internal clock does not adjust for Daylight Savings Time and therefore, will require a manual adjustment.

#### Software Version

The software version allows the user to view the software version in use by the control. This software controls the operation of the boiler. When a new software version becomes available, the existing control can be replaced with a new control to update the software.

Software version is read only.

#### Temperature units (°C / °F)

The control can be configured to display temperature in either °C or °F. This parameter can be changed by the user or the installer by accessing the *Temperature Units parameter*. The default is °F.

#### Space Heating (SH) and Domestic Hot Water (DHW) Night Setback Offset

Once the unit's internal clock has been set correctly, the Night Setback feature can be used to program a lower set point during unoccupied times. Both the space heating and DHW can be programmed for night setback. When in night setback, the control reduces the set point by a fixed amount. For space heating, it subtracts the space heating night setback offset for the SH user set point, or the calculated outdoor reset set point (if lower). For DHW, it subtracts the DHW night setback offset from the tank set point (*Tank Set point parameter*).

**NOTE:** The DHW night setback will not work without a tank sensor installed.

The installer may adjust the space heating night setback offset by accessing the *SH Night Setback Offset parameter* and the DHW night setback offset by accessing the *DHW Night Setback Offset parameter*. The minimum setting is 0°F (0°C) and the maximum setting is 90°F (50°C).

#### Space Heating (SH) and Domestic Hot Water (DHW) Night Setback On and Off Times

These are the times at which the SH Night Setback and DHW Night Setback Offsets become active and inactive. There are seven (7) stop times and seven (7) start times each for the SH and DHW night setback functions. Any start or stop time may be set to any time during the week. When a start time and a stop time are programmed for the same day and time, the stop time has priority (this is how a start time can be disabled). The installer can adjust the SH Night Setback start and stop times by accessing the parameter *SH NSB On/Off Times*. The installer can access the DHW Night Setback start and stop times by accessing the *DHW NSB On/Off Times parameter*. These settings can be adjusted as follows:

1. When the screen is first accessed, start and stop triggers 1 are displayed. If a different trigger number is desired, rotate the NAVIGATION dial until the desired trigger number appears. Once it is found, press the NAVIGATION dial to adjust the start and stop times. The day of the week for the start time will flash.
2. Rotate the NAVIGATION dial to adjust the day of the week of the start trigger. Once it is set to the desired day of the week, press the NAVIGATION dial again. The start time hour will flash.
3. Rotate the NAVIGATION dial to adjust the start time hour to the desired time. Press the NAVIGATION dial again. The start time minutes will flash.
4. This process may be continued until the start and stop days and times are adjusted as desired. When finished with this set of triggers, press the [SAVE] key.
5. Rotate the NAVIGATION dial to select another set of start and stop triggers, or press the [EXIT] key to return to the previous menu.

# 1 Service *(continued)*

## Night Setback Override

Any Night Setback On trigger currently active or scheduled within the next seven (7) days can be skipped. To skip a trigger, go to the Night Setback Status Screen and press the SKIP button. Rotate the NAVIGATION dial until the arrow (>) is next to the trigger you wish to skip. Press the NAVIGATION dial once. "SK" will appear next to that trigger to indicate that it will be skipped. You can restore an upcoming trigger by selecting that trigger, and pressing the NAVIGATION dial again. The "SK" next to that trigger will disappear.

To save any changes and return to the Home Screen, press the RIGHT SELECT [HOME] key. To return to the Status Screen without saving the changes, press the LEFT SELECT [EXIT] key.

## Display Timeout

This is the time in which the display remains illuminated. The range is 10 seconds to 10 minutes. The default is 10 minutes.

## Display Contrast

The contrast of the LCD display can be adjusted to improve readability. The contrast is adjusted automatically when the display board is tested at the factory, but different ambient conditions may warrant changing the setting. This parameter can be changed by accessing the *Display Contrast* setting. The range of this parameter is -10 to +10. The default setting is 0.

## Temperature Settings

### Space Heating Set Point

**CAUTION**

Mixing valves are required for the protection of any low temperature loops.

The range is space heat minimum set point to space heat maximum setpoint. The default space heating temperature is 125°F (52°C).

### Space Heating (SH) Minimum Set Point

The SH minimum set point sets the minimum water temperature set point that can be used for space heating operation. The user or installer will not be able to program the control with a lower SH set point. This parameter can only be changed by the installer by accessing *Minimum SH Set point parameter*. The temperature range of this parameter is 32°F (0°C) to the space heating maximum set point. The default value is 60°F (16°C).

### Space Heating (SH) Maximum Set Point

The SH maximum set point sets the maximum water temperature set point that can be used for space heating. The user or installer will not be able to program the control with a higher SH set point. This parameter can only be changed by the installer by accessing *Maximum SH Set point parameter*. The temperature range of this parameter is the space heating minimum set point to 61°F(16°C) to 215°F(102°C). The default value is 215°F (101°C).

## Offset Set Point

The SH offset sets how many degrees above set point the temperature has to go before the boiler will shut off. This parameter can only be changed by the installer by accessing parameter *Offset Set point parameters*. The temperature range of this parameter is 0°F to 20°F. The default value is 10°F.

## Differential Set Point

The SH differential sets how many degrees below the offset the temperature has to drop before the boiler turns back on. This parameter can only be changed by the installer by accessing the *Differential Set point parameters*. The range is 0°F to 60°F. The default is 20°F.

## Auto reset high limit

The smart control contains an auto reset high limit (ARHL) on the outlet of the boiler. Once the outlet temperature exceeds the ARHL setpoint, the boiler will shut down and lockout. Once the outlet temperature has dropped below this set point, the RESET button on the display can be pressed to reset this lockout. The maximum value for the ARHL is 225°F and is the default value.

# 1 Service

## Manual reset high limit

The smart control contains a manual reset high limit (MRHL) on the outlet of the boiler. Once the outlet temperature exceeds the MRHL setpoint, the boiler will shut down and lockout. Once the outlet temperature has dropped below this setpoint the reset button the display must be pressed to clear this error. The maximum value for the MRHL is 230°F and is the default value.

## Data Logging

### Reset log errors

The reset log errors function clears the last 10 errors log.

## Functions

### Service Mode Delay

By pressing the pin button on the front of the display for five (5) seconds, the control will be placed in Service Mode. This will override all other heat demands. The Service Mode allows the installer to set the unit to full power rate. The delay sets the length of time the boiler will stay in the Service Mode if no keys have been pressed before going back to its original state. This parameter can only be changed by the installer by accessing the *Service Mode Delay parameter*. The time range of this parameter is 1 to 10 minutes. The default value is 10 minutes.

### Freeze Protection Pump On

The SMART SYSTEM control will turn on the boiler and system pump outputs whenever the inlet temperature drops below this setting. This is done to prevent the water in the boiler from freezing. Certain low-temperature applications (such as snow melt) can operate at temperatures around freezing, so this setting needs to be lowered in these cases. The installer can adjust the temperature at which the pump outputs are turned on by accessing the *Freeze Protection Pump On parameter*. The minimum setting is -3°F (-19°C), and the maximum setting is 45°F (7.2°C). The default setting is 45°F (7.2°C).

### Freeze Protection On

If running the pumps does not prevent the inlet temperature from falling closer to freezing, the SMART SYSTEM control will enable the elements to minimum power rate. The installer can adjust the temperature at which the element heats the water by adjusting the *Freeze Protection Power On parameter* (FRZ POW ON). The minimum setting is -3°F (-19°C), and the maximum setting is the *Freeze Protection Pump On parameter*. The default setting is 37°F (2.8°C).

## Freeze Protection Boiler Differential

Once the boiler is on due to a low inlet temperature, the inlet temperature must increase by this amount before the boiler turns back off. The installer can adjust this differential by accessing the *Freeze Protection Boiler Differential parameter*. The minimum setting is 0°, and the maximum is 20°F (11°C). The default setting is 5°F (2.8°C).

## DHW Settings

### DHW Tank Set Point

By installing a tank sensor, the SMART SYSTEM control can perform the tank thermostat function. The SMART SYSTEM control automatically detects the presence of this sensor and generates a DHW call for heat when the tank temperature drops below the tank set point differential (*Tank Set point Differential parameter*), and finishes the call for heat when the tank temperature reaches tank set point. This parameter can be changed by the installer by accessing the *DHW Tank Set point parameter*. The temperature range of this parameter is from the tank minimum set point to the tank maximum set point. The default value is 120°F (49°C).

### Tank Set Point Differential

When a tank sensor is installed, the tank temperature must drop this amount below the tank set point (*DHW Tank Set point parameter*) before the boiler turns back on. The installer can adjust this setting by accessing the *Tank Set point Differential parameter*. The minimum setting is 0° (0°C), and the maximum is 40°F (22°C). The default setting is 6°F (3°C).

### DHW Boiler Set Point

When a DHW call for heat becomes active, the control will use the DHW boiler set point to determine the firing rate of the boiler based on the boiler outlet water temperature, or system temperature when DHW is programmed as a zone. This parameter can be changed by the installer by accessing the *DHW Boiler Set point parameter*. The temperature range of this parameter is 68°F (20°C) to 190°F (88°C). The default value is 180°F (82°C).

### DHW Boiler Offset

This parameter reflects the degrees above DHW boiler set point the temperature has to go before the boiler will shut off. The range is 0°F (0°C) to 20°F (11°C). The default setting is 5°F (2.8°C).

### DHW Boiler Differential

This parameter reflects the degrees below DHW boiler offset set point the temperature has to go before the boiler turns back on. The range is 0°F (0°C) to 60°F (33°C). The default setting is 10°F (6°C).

# 1 Service *(continued)*

## Tank Minimum Set Point

This setting controls the minimum tank set point for the tank temperature. The installer can adjust this by accessing the *Tank Minimum Set point parameter*. The minimum setting is 60°F (16°C) and the maximum setting is the maximum tank set point (*Tank Maximum Set point parameter*). The default value is 60° (16°C).

## Tank Maximum Set Point

This setting controls the maximum tank set point for the tank temperature. The installer can adjust this by accessing the *Tank Maximum Set point parameter*. The minimum setting is the minimum tank set point (*Tank Minimum Set point parameter*) and the maximum setting is 190°F (88°C). The default value is 190°F (88°C).

## Limiting for Indirect DHW Tank

This setting is to be used when heating an indirect DHW tank. This setting may be used when the tank is unable to accept all of the power available from the boiler. This parameter may be adjusted by the installer by accessing the *Limiting for Indirect DHW Tank parameter*. The default value is the maximum power for that model.

## DHW Type

This parameter determines whether the Lectrus boiler treats the indirect DHW tank as a separate load, or as a zone on the primary loop. When programmed as a separate load, the boiler will turn on the DHW pump and then turn off the boiler pump when an indirect DHW demand begins. When programmed as a zone, the boiler will turn on the DHW pump, leave the boiler pump on and change the system set point to the DHW boiler set point (*DHW Boiler Set point parameter*).

This setting may be changed by the installer by accessing the *DHW Type parameter*. The choices are NORMAL and ZONE. The default setting is NORMAL.

## SH/DHW Switching Time

When a boiler has a space heating demand and it receives a DHW demand, if DHW type is set to normal, it will immediately switch to the DHW demand and start a timer. Once the timer has expired, the boiler will switch back to the space heating demand and start another timer. Once this other timer expires, it will switch back to the DHW demand. The installer can adjust the length of time the boiler will service the space heating demand by accessing the *SH/DHW Switching Time parameter*. The minimum setting is 0 minutes and the maximum setting is 55 minutes. The default time is 30 minutes.

## DHW/SH Switching Time

When a boiler has a DHW demand and it receives a space heating demand, the SMART SYSTEM control will start a timer. Once the timer expires, it will stop the DHW demand and service the space heating demand. The installer can adjust the length of time the boiler will service the DHW demand by accessing the *DHW/SW Switching Time parameter*. The minimum setting is 0 minutes and the maximum setting is 55 minutes. The default setting is 30 minutes.

## DHW Forces Sys Pump (if DHW type is set as a zone)

When the indirect DHW tank is connected as a zone on the primary loop, the *DHW Forces Sys Pump* parameter tells the system pump if it must run when there is a DHW demand. To have the system pump constantly running during a DHW demand, set the *DHW Forces Sys Pump* parameter to YES (the parameter *DHW Blocks Sys Pump* must be set to NO). If this parameter and the *DHW Blocks Sys Pump* parameter are both set to NO, the system pump operation will be based strictly on the *System Pump Type* parameter setting. The default setting of this parameter is YES.

## DHW Blocks Sys Pump (if DHW type is set as a zone)

When the indirect DHW tank is connected as a zone on the primary loop, the *DHW Blocks Sys Pump* parameter tells the system pump if it is allowed to run during a DHW demand. To force the system pump to turn off during a DHW demand, set the *DHW Blocks Sys Pump* parameter to YES. The default setting is NO.

## Outdoor Reset

The option of controlling outdoor resets for low outdoor temperatures is available.

## Outdoor Low

When the outdoor air temperature drops to this point, the water temperature will be at the *Set point at Low Outdoor Temp* (FIG. 1-1 on page 24). If the outdoor air temperature drops further, the set point will continue to increase above this setting. This parameter can be changed by the installer by accessing the *Outdoor Low parameter*. The temperature range of this parameter is -39°F (-39°C) to high outdoor temperature set point. The default value is 25°F (-4°C).

## Outdoor High

When the outdoor air temperature rises to or above this point, the water temperature will be at the *Set point at High Outdoor Temp* (FIG. 1-1 on page 24). This parameter can be changed by the installer by accessing the *Outdoor High parameter*. The temperature range of this parameter is low outdoor temperature set point to 104°F (40°C). The default value is 70°F (21°C).

# 1 Service

Figure 1-1 Outdoor Air Reset Curve

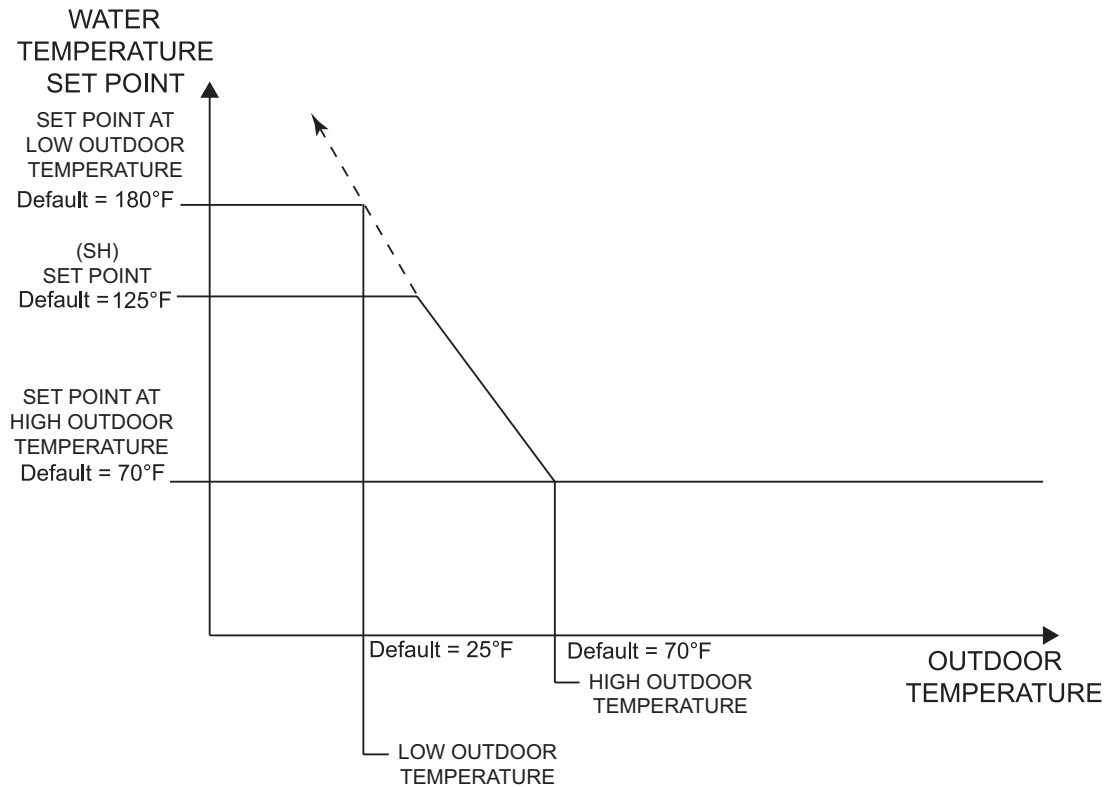

## Set Point at Low Outdoor Temperature

When the outdoor air temperature drops to the *Outdoor Low parameters*, the calculated set point will be at this setting (FIG. 1-1). If the outdoor air temperature drops further, the set point will continue to increase above this setting. However, if SH is set lower, the water temperature will be limited by this set point instead. This parameter can be changed by the installer by accessing the *Set point at Low Outdoor Temp parameter*. The temperature range of this parameter is 68°F (20°C) to 190°F (88°C). The default value is 180°C (82°C).

## Set Point at High Outdoor Temperature

When the outdoor air temperature rises to or above *Outdoor High parameters*, the calculated set point will be at this setting (FIG. 1-1). This parameter can be changed by the installer by accessing the *Set point at High Outdoor Temp parameter*. The temperature range of this parameter is 68°F (20°C) to 190°F (88°C). The default value is 70°F (21°C).

## Outdoor Air Shutdown

When the outdoor temperature rises above this point, the control will block the SH demand (DHW demands will still be active). This parameter can be changed by the installer by accessing the *Outdoor Air Shutdown SH1 parameter*. The temperature range of this parameter is 32°F (0°C) to 104°F (40°C). The default value is 70°F (21°C).

## Outdoor Air Shutdown Differential

The outdoor air shutdown differential parameter is the number of degrees below *Outdoor Air Shutdown SH1 parameter* the outdoor air temperature must go before the boiler will respond to the corresponding SH demand. This parameter can be changed by the installer by accessing the *Outdoor Air Shutdown Differential SH1 parameter*. The temperature range of this parameter is 0°F (0°C) to 54°F (30°C). The default value is 10°F (6°C).

## Shift Reset Curve

There is a shift reset parameter for the outdoor reset curve. The shift reset parameter shifts the actual set point above or below the calculated set point by the number of degrees in this parameter. This parameter can be changed by the installer by accessing the *Shift Reset Curve SH1 parameter*. The temperature range of this parameter is -18°F (-10°C) to 18°F (10°C). The default value is 0°F (0°C). This feature will be active if this parameter is set to anything other than 0°F (0°C).

# 1 Service *(continued)*

## Boost Temperature

If an SH demand lasts longer than the programmed time delay setting and there have been no DHW demands, the control will increase the water temperature set point by the amount in this parameter. If the SH demand continues through another time period, the set point will be increased again. This will continue until either the SH demand ends, a maximum of 20 increases has occurred, or SH1 maximum set point has been reached. Once the SH demand has been satisfied the set point will revert back to its calculated setting. The boost temperature can be changed by the installer by accessing the *Boost Temperature parameter*. The temperature range of this parameter is 0°F (0°C) to 25°F (14°C). The default value is 0°F (0°C). This feature will be active if this parameter is set to anything other than 0°F (0°C).

## Boost Time

The boost time parameter sets the amount of time that must elapse with an SH demand before the water temperature calculated set point will be increased. This parameter can be changed by the installer by accessing the *Boost Time parameter*. The time range for this parameter is 0 minutes to 55 minutes. The default value is 0 minutes.

## Anti-Cycling

### Anti-Cycling Time

Once the boiler turns off, a set amount of time must elapse before the control will respond to a new demand. The control will block the new heat demand and anti-cycling will be shown in the display until the time has elapsed or the water temperature drops below the *Anti-Cycling Override Differential parameter*. This parameter can be changed by the installer by accessing the *Anti-Cycling Time parameter*. The time range for this parameter is 1 minute to 10 minutes. The default value is 1 minute.

### Anti-Cycling Override Differential

The control will bypass the anti-cycling time if the inlet water temperature drops too much. The control will use the inlet water temperature present at the boiler when it shuts off as the starting point. If the inlet temperature drops below the temperature parameter, the control will abort anti-cycling and allow the boiler to power. This parameter can be changed by the installer by accessing the *Anti-Cycling Override Differential parameter*. The temperature range of this parameter is 0°F (0°C) to 54°F (30°C). The default value is 10°F (6°C).

## Modulation Factor

This parameter allows the installer to reduce the responsiveness of the temperature control function, for situations where, for example, redundant heating capacity is installed. The values that are available are 40, 50, 60, 70, 80, 90, and 100, with 100 being the most responsive. The default value is 100.

### Ramp Delay (Enable / Disable)

This parameter allows the installer to enable or disable the SH ramp delay. The default setting is disabled.

**Figure 1-2 Ramp Delay Interval**

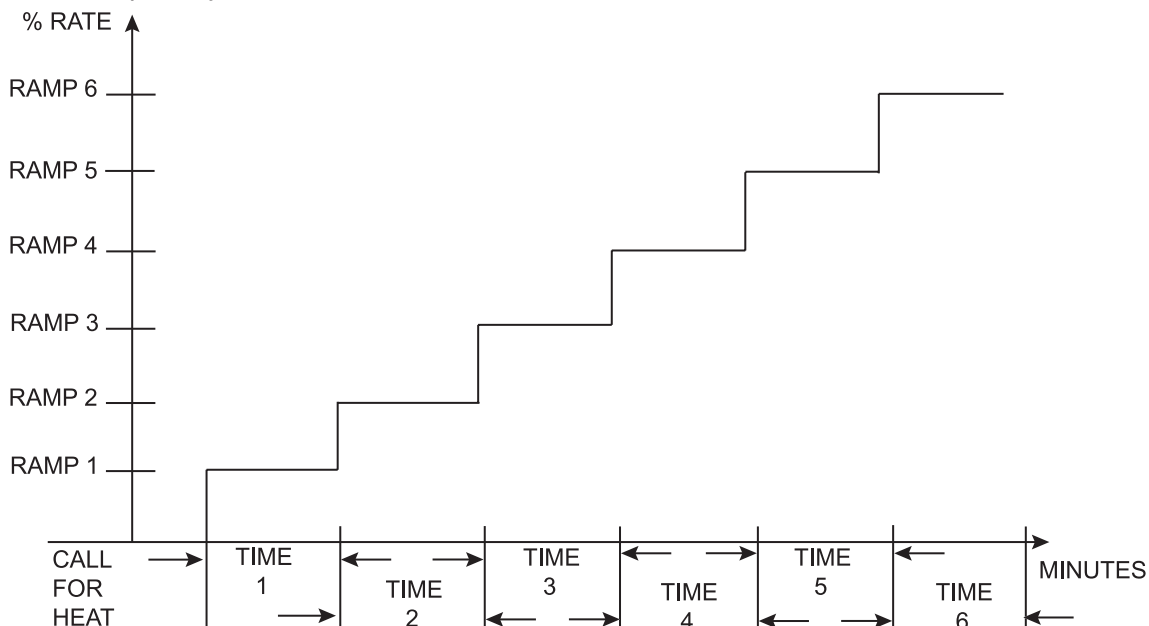

# 1 Service

## Ramp Settings

**NOTICE**

Please note that the brackets ([ ]) denote screen status.

The SMART SYSTEM control can be programmed to limit the element power for a fixed period of time at the start of a space heating or BMS set point demand. There are six (6) possible limits, each with their own time delay. The first limit applies as soon as the boiler starts. Once its time delay expires, the second limit is applied, and its timer begins. The control steps through these limits until the 6th (sixth) limit expires. Note, however, that the 6th limit will also limit the rate for the rest of that heat demand. The installer can adjust the element power limits and time delays by accessing the *Ramp Settings parameter*. Once this parameter is selected, the screen will show the step number, the time delay for that step and the limit value corresponding with that step. If the installer wishes to adjust one of the values in that step, he can press the NAVIGATION dial until the value he wishes to change is flashing. The installer can then rotate the NAVIGATION dial to adjust that value. If the installer presses the RIGHT SELECT [SAVE] key while the limit value is flashing, the step value will flash again. The installer can then select the next step and adjust the delay and limit values corresponding with that step.

When finished, the installer can press the RIGHT SELECT [SAVE] key to store the new settings, or the LEFT SELECT [EXIT] key to return to the **Anti-Cycling** parameter list without saving the changes. The delay value can be set between 0 minutes and 40 minutes. The limit value can be set between 0% and 100%.

## Control modes

### Controlling Sensor

The SH controlling sensor parameter selects the sensor the control will use to regulate the boiler element power. This parameter is adjustable by the installer by accessing the *Controlling Sensor parameter*. The sensor selections are as follows: The outlet sensor regulates the element power based on the outlet water temperature of the boiler and the inlet sensor regulates the firing rate based on the inlet water temperature of the boiler. If the outlet sensor is selected, and the optional system supply sensor is connected, the control will regulate the element power based on the system supply sensor temperature. The default sensor is the Outlet Sensor.

### Cascade Address

The boiler designated as the Leader needs to be programmed with address 0. All the Member boilers require addresses from 1 to 7, and the addresses must be different for each Member. The addresses can be in any order, regardless of the order in which the units are wired together. This parameter is adjustable by the installer by accessing the *Cascade Address parameter*. The outdoor air (if used) and system supply sensor must be connected to the Leader boiler. The default address is 1.

### Maximum Cascade Set Point

This parameter determines the set point used by the individual boilers in a Cascade when a system sensor is connected to the Leader boiler. When a boiler is commanded to power by the Leader boiler, it will attempt to achieve this temperature at its outlet. The Leader boiler will limit the modulation of the boiler(s) in order to hold the temperature at the system supply sensor to the user set point. If any of the boiler outlet temperatures reach the maximum cascade set point, that boiler will then modulate down on its own in order to keep its outlet temperature within the maximum cascade set point. Therefore, this parameter can be used to limit the outlet temperatures of all the boilers in a Cascade. Note that this parameter does not apply when the boiler is heating an indirect DHW tank programmed as normal. This parameter is adjustable by the installer by accessing the *Maximum Cascade Set Point parameter*. The temperature range of this parameter is 32°F (0°C) to 190°F (88°C). The default maximum cascade set point is 185°F (85°C).

### Cascade Offset

This parameter determines how much the temperature must go above set point before the lead boiler will turn off. This parameter can be adjusted by the installer by accessing the *Cascade Offset parameter*. The temperature range of this parameter is 0° to 20°F (11°C) The default value is 10°F (6°C).

### Cascade Differential

This parameter determines how much the temperature must go below the turn off temperature (Set point + Offset) before the lead boiler turns on. This parameter can be adjusted by the installer by accessing the *Cascade Differential parameter*. The temperature range of this parameter is 0°F to 60°F (33°C) The default value is 20°F (11°C).

### Cascade Type (L/L / EFF)

There are two (2) options for the way a Cascade divides the load between its heaters. The first is Lead/Lag, designated as L/L in the menu. This method is used when it is desired to have the least amount of total flow through the boilers. This method will modulate the last two (2) boilers that are working. This provides for smooth transitions when a boiler turns on or off. When the last boiler reaches 100% and the calculated load is still increasing, it will start the next boiler at 20% and reduce the previous boiler to 80%, thus eliminating the sudden jump in total output of the Cascade. When the calculated load is decreasing and the last boiler gets down to 20% power, it will hold it there and start lowering the firing rate on the next-to-last boiler. When the next-to-last boiler reaches 20%, it will turn the last boiler off and raise the rate of the next-to-last boiler to 40%, thus eliminating the sudden drop in total output of the Cascade.

# 1 Service *(continued)*

The other Cascade divider method is Efficiency Optimization, designated as EFF in the menu. This method is used, as the name implies, when it is desired to have the most efficient system. When the first boiler reaches 100% rate, it lowers its rate to 50% and turns on the next boiler at 50%. The two (2) boilers then modulate at the same rate.

As the calculated load increases further and both boilers ramp up to 100%, it lowers the rate of the first two (2) boilers to 67% and brings the next boiler on at 67%. The three (3) boilers then modulate together. As the calculated load decreases, the boilers will reach 20%, at which time the last boiler (the third in our example) will turn off and the Cascade will increase the rates of the remaining boilers to provide the equivalent total output as before ( $(3 \times 20\%) / 2 = 30\%$  in our example).

Efficiency optimization is automatically selected when boilers of different sizes are programmed into the Leader control (see *Boiler Size* on page 26).

## Minimum On/Off Time

In order to prevent units in a Cascade from short cycling, this parameter defines the minimum ON and OFF time for each unit. The installer can adjust this time by accessing the *Minimum On/Off Time* parameter. The minimum setting is 0 seconds and the maximum setting is 10 minutes. The default is 30 seconds.

## Minimum Next On Time

In order to reduce the risk of temperature overshoot with a Cascade, this parameter defines the minimum time delay from starting one unit until the next unit may be started. The installer can adjust this time delay by accessing the *Minimum Next On Time* parameter. The minimum setting is 0 minutes and the maximum setting is 10 minutes. The default is 60 seconds.

## Minimum Number of Pumps On

When the boiler is a Cascade Leader, it can force a minimum number of boiler pump outputs to be on continuously, regardless of how many boilers are firing. This is normally used when the boilers are piped in a full-flow configuration, and the boiler pump outputs are controlling isolation valves. The Leader will force the boiler pump output on the highest priority boiler to turn on first, then the boiler pump output on the second highest priority boiler, and so forth, until the minimum number of pump outputs are turned on. The range of this parameter is 0 to 8. The default value is 0.

## Alternate Leader

This parameter allows the Member 1 boiler to automatically assume control of the Cascade should it lose communication with the Leader boiler. When programmed to YES, it is recommended that the Member 1 boiler have its own set of external sensors installed (such as the system supply sensor), to maintain the same level of temperature control as with the Leader boiler. Voltage signals (such as the 0 - 10V system pump speed input) can be connected to both boilers.

### WARNING

DO NOT connect the sensors connected to the Leader boiler to the Member 1 boiler. The actual water temperatures will be higher than expected, which could lead to property damage, personal injury, or death.

When communication is re-established with the Leader boiler, Member 1 will automatically relinquish control of the Cascade to the Leader boiler.

The default value of this parameter is NO.

## Boiler Size

Outside of Cascade, this parameter will set the KW of the boiler. When boilers of different sizes are connected in a Cascade, the Leader boiler must know the size of each boiler in that Cascade. The Boiler Size parameters allow the installer to see the size based on the Cascade address. This screen shows the Cascade address, the type ELECTRIC, and the size of the boiler with that address in kW:

1. When the Boiler Size screen is first accessed, Cascade Address (SELF) is shown.
2. Press the NAVIGATION dial twice to access the Input setting. Rotate the NAVIGATION dial to increase the boiler input. Input settings can be adjusted in increments of 15kW. When the approximate boiler size is shown, press the RIGHT SELECT [SAVE] key.
3. Rotate the NAVIGATION dial to select the address of the next boiler in the Cascade.
4. The information of next boiler present on the cascade will be shown.
5. Once the size of all boilers in the Cascade has been confirmed, press the LEFT SELECT [EXIT] key to return to the Control Modes menu.
6. If no other parameters are to be adjusted, press the RIGHT SELECT [HOME] key to save the new settings and return to the Status screens.

The SMART SYSTEM control automatically uses the Efficiency Optimization Cascade type when controlling boilers of different sizes.

If the Leader boiler is controlling larger boilers (e.g., Copperfin II), those members will send their sizes to the Leader boiler automatically. Do not program those sizes into the Leader boiler.

# 1 Service

## Building Management System (BMS)

### BMS

The set point or modulation of the boiler may be controlled through the 0 - 10V BMS input, BACnet, or ModBus. When the *BMS parameter* is set to INACTIVE, the 0 - 10V input will be ignored. When set to ACTIVE, the set point or modulation will be controlled by the voltage on the 0 - 10V input (in the case of 0 - 10V BMS control), or the 0 - 10V input value received through ModBus or BACnet. The default value is INACTIVE.

### BMS Type

When programmed for BMS control through the 0 - 10V BMS input or through ModBus/BACnet, the 0 - 10V signal can be interpreted as either a modulation command or a set point. When the *BMS Type* parameter is set to POWER, the 0 - 10V signal will control the modulation. When set to SETPOINT, the 0 - 10V signal will control the SH set point. The default setting is SETPOINT.

### Set Point at Minimum Volts

When programmed for BMS control through the 0 - 10V BMS input or through ModBus/BACnet and the BMS Type is programmed as SETPOINT, the set point represented by the *Volts at Minimum* parameter is set by the *Set Point at Minimum Volts* parameter. The minimum value is 32°F (0°C) and the maximum is the *Set Point at Maximum Volts* setting. The default value is 70°F (21°C).

### Set Point at Maximum Volts

When programmed for BMS control through the 0 - 10V BMS input or through ModBus/BACnet and the BMS Type is programmed as SETPOINT, the set point represented by the *Volts at Maximum* parameter is set by the *Set Point at Maximum Volts* parameter. The minimum value is the *Set Point at Minimum Volts* setting and the maximum is 190°F (88°C). The default value is 180°F (82°C).

### Rate at Minimum Volts

When programmed for BMS control through the 0 - 10V BMS input or through ModBus/BACnet and the BMS Type is programmed as POWER, the modulation percentage represented by the *Volts at Minimum* parameter is set by the *Rate at Minimum Volts* parameter. The minimum value is 0% and the maximum is the *Rate at Maximum Volts* setting. The default value is model dependant.

### Rate at Maximum Volts

When programmed for BMS control through the 0 - 10V BMS input or through ModBus/BACnet and the BMS Type is programmed as POWER, the modulation percentage represented by the *Volts at Maximum* parameter is set by the *Rate at Maximum Volts* parameter. The minimum value is the *Rate at Minimum Volts* setting and the maximum is 100%. The default value is 100%.

### Volts at Minimum

When programmed for BMS control through the 0 - 10V BMS input or through ModBus/BACnet, the *Volts at Minimum* parameter should be set to the minimum voltage signal sent to the SMART SYSTEM control. The range of this parameter is 0.0V to the *Volts at Maximum* value. The default setting is 2.0V.

### Volts at Maximum

When programmed for BMS control through the 0 - 10V BMS input or through ModBus/BACnet, the *Volts at Maximum* parameter should be set to the maximum voltage signal sent to the SMART SYSTEM control. The range of this parameter is the *Volts at Minimum* value to 10.0V. The default value is 10.0V.

### BMS Thermostat Input

When controlling the boiler through the 0 - 10V BMS input, BACnet, or ModBus, the boiler can be enabled one of two ways. With the *BMS Thermostat Input parameter* set to ACTIVE, the boiler will be enabled by closing the Heat/Loop Demand 1 input. When set to INACTIVE, the boiler will be enabled by the voltage level on the 0 - 10V input (in the case of 0 - 10V BMS control), or the 0 - 10V input value received through BACnet or ModBus. The default value is INACTIVE.

### On Volts

When programmed for BMS control through the 0 - 10V BMS input or through ModBus/BACnet and the BMS Thermostat Input is set to INACTIVE, the *On Volts* parameter determines the 0 - 10V BMS input voltage at which the boiler is enabled. The minimum value is 0.5V and the maximum is 10.0V. The default value is 2.0V.

### Off Differential Volts

When programmed for BMS control through the 0 - 10V BMS input or through ModBus/BACnet and the BMS Thermostat Input is set to INACTIVE, the *Off Differential Volts* parameter determines how far below the *On Volts* setting the 0 - 10V BMS input voltage must be in order to disable the boiler. The minimum value is 0.2V and the maximum is the *On Volts* setting. The default value is 1.0V.

### ModBus/BACnet

When BMS is set to ACTIVE (see BMS Active / Inactive) and the boiler is being controlled through BACnet or ModBus, set *ModBus/BACnet parameter* to ACTIVE. Otherwise, set the *ModBus/BACnet parameter* to INACTIVE. Note that the boiler can still be monitored by ModBus or BACnet with this parameter set to INACTIVE. The default value is INACTIVE.

# 1 Service *(continued)*

## BAS T/O

This is the amount of time the unit controls will wait to receive a communication string from the BMS controller before reverting back to its own internal parameters. This parameter is adjustable by the installer by accessing the *BAS T/O* parameter. The adjustment range of this parameter is 5 seconds to 2 minutes. The default value is 10 seconds.

## Circulation pumps

### System Pump Delay

The system pump delay parameter sets the length of time the system pump (if connected) will run after a SH demand has been satisfied or outdoor shutdown has begun. This parameter is adjustable by the installer by accessing the *System Pump Delay* parameter. The time range for this parameter is 1 second to 40 minutes. The default time is 30 seconds.

### Boiler Pump Delay

The SH pump delay parameter sets the length of time the boiler pump will run after a SH demand has been satisfied. Setting the delay time to 0 will disable the pump. This parameter is adjustable by the installer by accessing the *Boiler Pump Delay* parameter. The time range for this parameter is 1 second to 40 minutes. The default time is 1 minute.

### DHW Pump Delay

The DHW pump delay parameter sets the length of time the DHW pump (if connected) will run after a DHW demand has been satisfied. This parameter is adjustable by the installer by accessing the *DHW Pump Delay* parameter. The time range for this parameter is 10 seconds to 40 minutes. The default time is 1 minute.

### System Pump Anti-Seize Delay

If the boiler pump does not run for 24 hours, it will be turned on briefly to prevent it from seizing. The length of time it runs is determined by the *System Pump Anti-Seize Delay* parameter. The range of this setting is 0 seconds to 40 minutes. The default setting is 20 seconds.

### Boiler Pump Anti-Seize Delay

If the boiler pump does not run for 24 hours, it will be turned on briefly to prevent it from seizing. The length of time it runs is determined by the *Boiler Pump Anti-Seize Delay* parameter. The range of this setting is 0 seconds to 40 minutes. The default setting is 20 seconds.

### DHW Pump Anti-Seize Delay

If the boiler pump does not run for 24 hours, it will be turned on briefly to prevent it from seizing. The length of time it runs is determined by the *DHW Pump Anti-Seize Delay* parameter. The range of this setting is 0 seconds to 40 minutes. The default setting is 20 seconds.

## System Pump Type

The system pump can be programmed to operate in response to the Room Thermostat inputs, or to run continuously until the SH demands go into Outdoor Shutdown. To program the system pump to operate only with a space heating call for heat, set the *System Pump Type* parameter to CFH. To program the system pump to run continuously until outdoor shutdown starts, set the *System Pump Type* parameter to WWSD. The default setting is CFH.

## Boiler Pump Delta T Set Point

When using a variable speed boiler pump and controlling it by means of the 0 - 10V Boiler Pump Speed Output, the boiler pump will be controlled in order to maintain a minimum Delta T across the heat exchanger in the boiler (other factors may override this target). This feature is to be used with Primary / Secondary piping systems only. A system supply sensor MUST be installed. This parameter sets the target minimum Delta T it will use. The range of this parameter is 15°F (8°C) to 60°F (33°C). The default value is 20°F (11°C).

## Boiler Pump Minimum Voltage

The speed of the boiler pump can be controlled by the SMART SYSTEM control in order to maintain a minimum  $\Delta T$  through the heat exchanger. Thus, as the firing rate decreases, the speed of the boiler pump can decrease as well. The SMART SYSTEM control outputs a 0 - 10V signal to the boiler pump to control its speed. The *Boiler Pump Minimum Voltage* parameter determines the minimum voltage given to the boiler pump, thereby setting its minimum speed. The range of this setting is 2.5V to 10V. The default setting is 3.5V.

## Boiler Pump Maximum Voltage

The speed of the boiler pump can be controlled by the SMART SYSTEM control to maintain a minimum DT through the heat exchanger. Thus, as the firing rate decreases, the speed of the boiler pump can decrease as well. The SMART SYSTEM control outputs a 0 - 10V signal to the boiler pump to control its speed. The Boiler Pump Maximum Voltage parameter determines the maximum voltage given to the boiler pump there by setting the maximum speed. The range of this setting is 2.5V to 10V. The default setting is 10V.

## Boiler Pump Standby Voltage

This parameter is the voltage given to the boiler pump when the unit is in standby, and the pump doesn't need to run. The range of this setting is 0V to 10V. The default setting is 0V.

## Boiler Pump Type

The boiler pump can be programmed to operate in response to the room thermostat input, to run continuously, or until the outdoor shutdown is met. To program the boiler pump to operate only with a space heating call, set the parameter to CFH (Call For Heat) to run with the outdoor sensor set to WWSD (Warm Weather Shut Down). The default is CFH.

# 1 Service

## Service Notification

### Service Notification in Months

When the boiler control determines that a scheduled service is due based on days of installation, the boiler display will turn yellow, and a new status screen will appear informing the user that maintenance is required. This parameter is adjustable by the installer by accessing the *Service Notification in Months* parameter. The time range for this parameter is 0 months to 100 months. The default time is 13 months.

### Service Notification Running Time

When the boiler control determines that a scheduled service is due based on the hours of actual operation, the boiler display will turn yellow, and a new status screen will appear informing the user that maintenance is required. This parameter is adjustable by the installer by accessing the *Service Notification Running Time* parameter. The time range for this parameter is 0 hours to 17,500 hours. The default time is 8,760 hours.

### Service Notification Cycles

When the boiler control determines that a scheduled service is due based on the number of boiler cycles, the boiler display will turn yellow, and a new status screen will appear informing the user that maintenance is required. This parameter is adjustable by the installer by accessing the *Service Notification Cycles* parameter. The range for this parameter is 0 cycles to 100,000 cycles. The default is 50,000 cycles.

### Reset Maintenance Reminder

Once servicing has been completed, the service notification counter should be reset. This parameter can be reset by the installer by accessing the *Reset Maintenance Reminder* parameter. Once accessed, press the RESET key to reset the service notification counter.

### Service Name and Phone Number

#### NOTICE

Please note that the brackets ([ ]) denote screen status.

When a Maintenance Reminder timer or counter has expired, a Maintenance Reminder screen will appear on the display. By programming the installer's name and phone number, this information will appear on the Maintenance Reminder Screen at that time. This can be programmed by accessing the *Service Name and Phone Number* parameter. When selected, another menu will appear with PHONE and NAME.

1. Rotate the NAVIGATION dial to point to the name/phone number to program and press the NAVIGATION dial. The screen will now display the selected item (either PHONE or NAME).

2. Press the NAVIGATION dial again. A cursor will appear at the bottom of the screen. By rotating the NAVIGATION dial, various numbers and characters will appear. When the desired number/character is found, press the NAVIGATION dial. The cursor will move to the next position.
3. Repeat this procedure until the entire message is entered. If you make a mistake and wish to back up one character, rotate the NAVIGATION dial until the back arrow (←) character is displayed and press the NAVIGATION dial.
4. When finished, press the RIGHT SELECT [SAVE] key to return to the previous menu.

## Basic Setup

The Basic Setup Menu contains the most frequently used parameters from the list above. See the descriptions above to set these parameters.

## Loch-N-Link™

Parameter files can be copied directly to and from a USB flash drive. When USB is selected from the Main Menu, the display will ask you to insert a flash drive into the USB-A (rectangular) port next to the display. Once a drive is inserted, the display will search the root directory of this drive for a folder named "lochivar". If it does not find it, the display will ask if you want it to create this folder? Press either the [YES] or [NO] key. If you press [NO], no further operations are allowed, so you must remove the flash drive. If you press [YES], it will create the folder in the flash drive. If the flash drive contains a folder named "lochivar", the display will show all of the parameter files stored in that folder.

If you wish to copy the parameters from the Smart System control into the flash drive, press the [SAVE] key. The display will create a file name based on the current date and time (year-month-date-hours-minutes). If you wish to cancel this operation, press the [NO] key. If you wish to change the filename, press the NAVIGATION dial. The first character of the filename will flash. Rotate the NAVIGATION dial to change this character. Once it is correct, press the NAVIGATION dial again, and edit the next character as before. When the new filename is ready, press the [SAVE] key. The control will save the parameters to the flash drive, and the new file will appear in the list of parameter files. Press the [EXIT] key to return to the Main Menu.

If you wish to copy a parameter file from the flash drive into the Smart System control, rotate the NAVIGATION dial until the file you wish to copy is selected. Press the NAVIGATION dial once. The display will ask you if you want to load the parameters from the file you selected. You can press [NO] to cancel the operation, or press [YES] to continue with writing the parameters into the control. Once the loading process is complete, the display will return to the Main Status Screen.

# 1 Service

## Factory Installed Options

### Solenoid Interlock

Front door – when power to the boiler is on, the solenoid is energized, and the unit door is locked. To de-energize and unlock the front door, the power must be turned off at the unit disconnect. Using the ON/OFF rocker switch located at the back of the unit only will only affect the controls.

Units factory equipped with a solenoid interlock have a small window on the front door to visually troubleshoot the modulation board.

### Enable/ Disable E-Stop Button

A mushroom button located on the front door that provides an emergency enable/disable to the unit control. It has a similar outcome to the ON/OFF rocker switch located at the back of the unit.

The mushroom button once pressed cuts the 120VAC power to the controls. The controls turn off, the contactors go back to a normally open position and no power flow to the elements.

To re-arm and restart the unit control, rotate the mushroom button clockwise about a 1/8 turn.

#### NOTICE

If the unit is factory equipped with a Solenoid Interlock, the enable/disable E-stop button will not de-energize the solenoid and the unit door will remain locked.

#### CAUTION

The enable/disable E-stop button doesn't cut power to the high voltage going to the unit. It is not a unit high voltage disconnect.

### High Voltage Plexiglass Screen

A plexiglass screen covering high voltage components (fuses and relays) inside the unit. To access any of the components located behind the screen, remove the 6x 1/4" bolts holding it in place.

### Powermeter

The power and energy meter displays instantaneous values for each high voltage phase, including:

- voltage (L-L)
- current (L-L)
- reactive power (VAr)
- active power (W)
- apparent power (VA)
- frequency (Hz)
- power factor (PF)
- THD (total harmonic distortion) voltage and current
- % max load
- total energy (kWh or kVah)

The power meter turns ON when the unit is switched on, using 120 VAC from the high voltage transformer. Each phase is connected to the power meter and has a dedicated CT (current transformer). During installation the phases must be passed through each factory provided CT (see wiring diagram below).

Use the left button to access the various pages, or the right button for a continuous automatic scroll.

**Figure 1-3** Powermeter Screen and Button Location

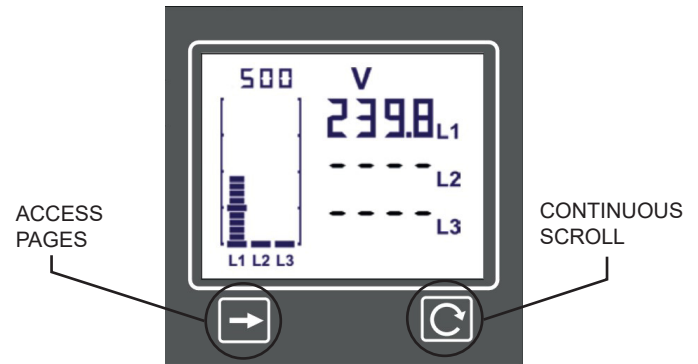

For more information and other functionalities (such as Modbus, digital and analog output connections, programmable scale, custom alarm, ...) consult <https://www.trumeter.com/product/apm-power-meter/>.

**Figure 1-4** Powermeter Connections - Three Phase (no neutral)

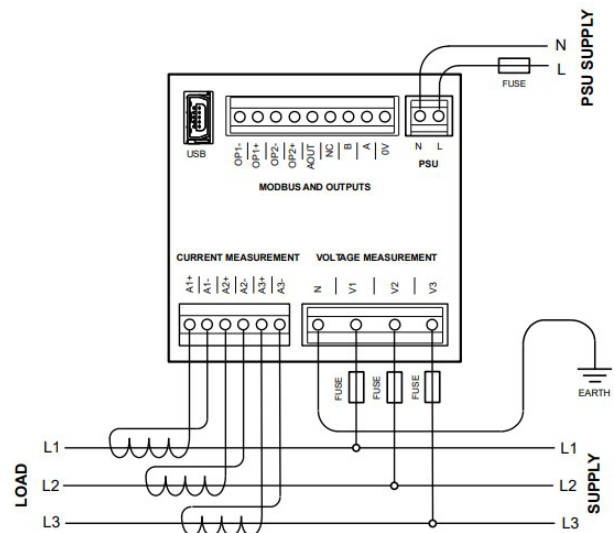

# 1 Service

## Ground Fault Relay

The ground fault detection relay is a self-powered ground-fault and phase-voltage indication system for three-phase systems. It provides ability to interrupt power to the boiler when use in conjunction with a customer provided shunt trip in a high ground fault current incident. Voltage connections are provided for 208, 240, 480, and 600 VAC systems. A solid-state relay output provides indication of a ground fault. The output relay is closed when the three phase neutral voltage shifts as the result of ground leakage.

The relay has four LED'S: Fault, A, B, and C. Three green LED's on the ground fault relay indicate the presence of phase-to-ground voltage and one red LED indicates a ground fault. The phase LED intensity is a function of line-to-ground voltage providing visual indication of phase balance. There are cases when one of the three phase indicators is off but no ground fault is indicated. This occurs on an ungrounded system when there is a phase loss. Ground fault indication is still enabled and will be activated when either of the energized phases develops a ground fault.

A solid-state normally open ground-fault-indication relay output is at terminals 16 and 17. The output relay is closed when the three-phase neutral shifts more than 20 Vac with respect to ground for the "L" voltage inputs (208 / 240 VAC) and 40 Vac with respect to ground for the "H" voltage inputs (480 / 600 VAC).

### NOTICE

The relay output has a rating of 100 mA at 120 Vac/Vdc and has a 35-Ω closed resistance.

### NOTICE

When used with a shunt trip, if a fault is detected and the power cut, the ground fault module will turn off since it takes its power for the high voltage.

### NOTICE

Bonding terminal (G) must be connected to ground for correct fault indication and to ensure that fault potential is not transferred to the display.

For more information consults <https://www.littelfuse.com/>, model EL3100-00.

Figure 1-5 Simplified Circuit Diagram

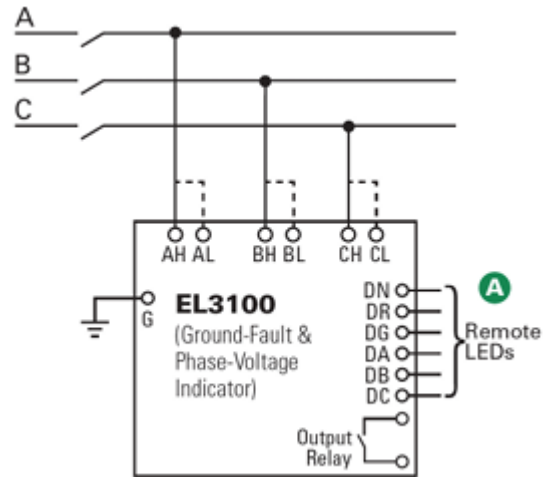
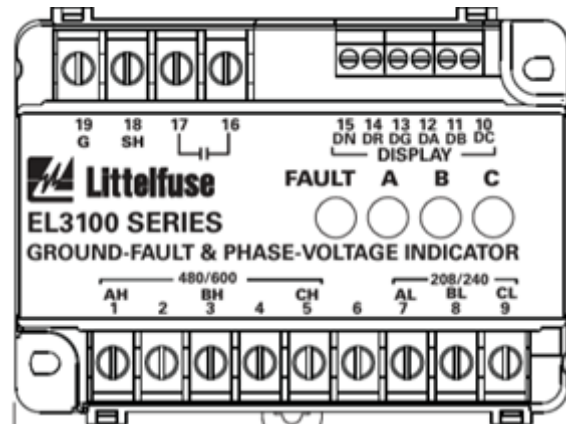

Figure 1-6 Ground-Fault & Phase-Voltage Indicator



## Field Installed Options

### Disconnect and Fused Disconnect

To install and operate the disconnect or the fused disconnect, refer to the manufacturer's provided instructions and documentation along with any applicable local code.

## 2 Maintenance

### Maintenance and annual startup

Table 2-1 Service and Maintenance Schedules

<b>Service technician</b> (see the following pages for instructions)		<b>Owner maintenance</b> (see the Lectrus User's Information Manual for instructions)	
<b>ANNUAL START-UP</b>	<b>General:</b>	<b>Daily</b>	<ul style="list-style-type: none"> <li>• Address reported problems</li> <li>• Inspect interior; clean and vacuum if necessary;</li> <li>• Check for leaks</li> <li>• Check system water pressure/system piping/expansion tank</li> <li>• Check fill water meter</li> <li>• Test boiler water. When test indicates, clean system water with approved system restorer following manufacturer's information.</li> <li>• Check control settings</li> <li>• Check wiring and connections</li> <li>• Perform start-up checkout and performance verification per Section 10 in the Lectrus Installation and Operation Manual.</li> <li>• Test low water flow conditions.</li> </ul>
		<b>Monthly</b>	<ul style="list-style-type: none"> <li>• Check boiler area</li> <li>• Check pressure/temperature gauge</li> <li>• Check relief valve</li> <li>• Check magnetic separator</li> </ul>
		<b>Periodically</b>	<ul style="list-style-type: none"> <li>• Test low water cutoff</li> <li>• Reset button (low water cutoff)</li> </ul>
		<b>Every 6 months</b>	<ul style="list-style-type: none"> <li>• Check boiler piping for leaks</li> <li>• Operate relief valve</li> </ul>
		<b>End of season month</b>	<ul style="list-style-type: none"> <li>• Shut boiler down (unless boiler used for domestic hot water)</li> </ul>

## 2 Maintenance

### **⚠ DANGER**

If this boiler may be frozen, immediately shut off power to the appliance and contact the factory for further instructions. Operation when the boiler, internal pipes, or pressure relief valves are frozen, will result in internal pressure build-up and a deadly steam explosion. Neither the Freeze Protection feature of the boiler control module nor the use of glycol eliminates the possibility of freezing.

### **⚠ WARNING**

Follow the Service and maintenance procedures given throughout this manual and in component literature shipped with the boiler. Failure to perform the service and maintenance could result in damage to the boiler or system. Failure to follow the directions in this manual and component literature could result in severe personal injury, death, or substantial property damage.

### **⚠ WARNING**

The boiler should be inspected annually only by a qualified service technician. In addition, the maintenance and care of the boiler designated in Table 2-1 and explained on the following pages must be performed to assure maximum boiler efficiency and reliability. Failure to service and maintain the boiler and system could result in equipment failure.

### **⚠ WARNING**

Electrical shock hazard – Turn off power to the boiler before any service operation on the boiler except as noted otherwise in this instruction manual. Failure to turn off electrical power could result in electrical shock, causing severe personal injury or death.

### Address reported problems

1. Inspect any problems reported by the owner and correct before proceeding.

### Inspect boiler area

1. Verify that boiler area is free of any combustible materials, gasoline and other flammable vapors and liquids.
2. Verify that air intake area is free of any of the contaminants listed in Section 1 of the Lectrus Installation and Operation Manual. If any of these are present in the boiler vicinity, they must be removed.

### Inspect boiler interior

1. Remove the front access cover and inspect the interior of the boiler.
2. Vacuum any sediment from inside the boiler and components. Remove any obstructions.

### Check all piping for leaks

### **⚠ WARNING**

Eliminate all system or boiler leaks. Continual fresh makeup water will reduce boiler life. Minerals can build up in sections, reducing heat transfer, overheating boiler, and causing boiler failure. Leaking water may also cause severe property damage.

1. Inspect all water piping and verify to be leak free.
2. Look for signs of leaking lines and correct any problems found.

### Check water system

1. Verify all system components are correctly installed and operational.
2. Check the cold fill pressure for the system. Verify it is correct (must be a minimum of 12 psi (82.7 kPa)).
3. Watch the system pressure as the boiler heats up (during testing) to ensure pressure does not rise too high. Excessive pressure rise indicates expansion tank sizing or performance problem.

### Check expansion tank

Expansion tanks provide space for water to move in and out as the heating system water expands due to temperature increase or contracts as the water cools. Tanks may be open, closed or diaphragm or bladder type. See Section 3 - Hydronic Piping of the Lectrus Installation and Operation Manual for suggested best location of expansion tanks and air eliminators.

### Check fill water meter

Check fill water meter for water usage. If the amount exceeds 5% of your system volume, you could have a leak. Have the system checked for leaks and fixed by a qualified service technician.

### Test boiler water

Test boiler water. Reference the Crest Installation and Operation Manual for guidelines. When test indicates, clean system water with approved system restorer following the manufacturer's information.

### Check boiler relief valve

Inspect the relief valve and lift the lever to verify flow. Before operating any relief valve, ensure that it is piped with its discharge in a safe area to avoid severe scald potential. Read Section 3 - Hydronic Piping of the Lectrus Installation and Operation Manual before proceeding further.

## 2 Maintenance *(continued)*

### **⚠ WARNING**

Safety relief valves should be re-inspected **AT LEAST ONCE EVERY THREE YEARS**, by a licensed plumbing contractor or authorized inspection agency, to ensure that the product has not been affected by corrosive water conditions and to ensure that the valve and discharge line have not been altered or tampered with illegally. Certain naturally occurring conditions may corrode the valve or its components over time, rendering the valve inoperative. Such conditions are not detectable unless the valve and its components are physically removed and inspected. This inspection must only be conducted by a plumbing contractor or authorized inspection agency – not by the owner. Failure to re-inspect the boiler relief valve as directed could result in unsafe pressure buildup, which can result in severe personal injury, death, or substantial property damage.

### **⚠ WARNING**

Following installation, the valve lever must be operated **AT LEAST ONCE A YEAR** to ensure that waterways are clear. Certain naturally occurring mineral deposits may adhere to the valve, rendering it inoperative. When manually operating the lever, water will discharge and precautions must be taken to avoid contact with hot water and to avoid water damage. Before operating lever, check to see that a discharge line is connected to this valve directing the flow of hot water from the valve to a proper place of disposal. Otherwise severe personal injury may result. If no water flows, valve is inoperative. Shut down the boiler until a new relief valve has been installed.

- After following the above warning directions, if the relief valve weeps or will not seat properly, replace the relief valve. Ensure that the reason for relief valve weeping is the valve and not over-pressurization of the system due to expansion tank waterlogging or under sizing.

### **Check all boiler wiring**

- Inspect all boiler wiring, making sure wires are in good condition and securely attached.

### **Check control settings**

- Set the SMART SYSTEM control module display to Parameter Mode and check all settings. See Section 1 of this manual. Adjust settings if necessary. See Section 1 of this manual for adjustment procedures.
- Check settings of external limit controls (if any) and adjust if necessary.

### **Perform start-up and checks**

- Start boiler and perform checks and tests specified in Section 10 - Start-up of the Lectrus Installation and Operation Manual.
- Verify cold fill pressure is correct and that operating pressure does not go too high.

### **Review with owner**

- Review the Lectrus User's Information Manual with the owner.
- Emphasize the need to perform the maintenance schedule specified in the Lectrus User's Information Manual (and in this manual as well).
- Remind the owner of the need to call a licensed contractor should the boiler or system exhibit any unusual behavior.
- Remind the owner to follow the proper shutdown procedure and to schedule an annual start-up at the beginning of the next heating season.

### **Cleaning boiler**

- Disconnect power to shut down the boiler:
  - Do not drain the boiler unless it will be exposed to freezing temperatures. If using freeze prevention fluids in the system, do not drain.
- Allow time for the boiler to cool to room temperature if it has been enabled.
- Remove the bezel from the unit.
- Use a vacuum cleaner to remove any accumulation on the boiler heating surfaces. Do not use any solvent.
- Using a clean cloth dampened with warm water, wipe out the boiler. For deep stains, use a nylon brush with warm water. Rinse out debris with a low-pressure water supply.
- Resume operation.

### **⚠ CAUTION**

\* Do NOT use a metal brush.

## 2 Maintenance

### Test low water flow conditions

**NOTICE**

This test is to be carried out once the Lectrus boiler is completely piped in with adequate water flow. Once the test is completed, ensure that the isolation valve is opened up to allow full water flow.

**NOTE:** This lockout is a soft lockout. Once the  $\Delta T$  has decreased to an acceptable level and there is a call for heat, the unit will cycle again to meet the demand.

1. Locate the pinhole above the RESET button on the display (see page 6). Insert a thin wire or paper clip into the hole, press the button once, then hold for 5 seconds. This will place the boiler in service mode. The boiler will power up and run at 100% power.
2. Allow the unit to get to 100% power.
3. Let the outlet temperature stabilize and note the delta T.
4. Slowly shut off the isolation valve on the outlet piping to reduce the flow. Do not shut off the unit completely.
5. As the isolation valve close, the delta T should increase. When the delta T reaches 70°F(39°C) the unit will reduce the power to the elements.
6. When the delta T reaches 80°F (44°C) the control will stop the unit and go into blocking.
7. Open the isolation valve entirely and resume normal operation.

Figure 2-3 Adjust outlet isolation valve

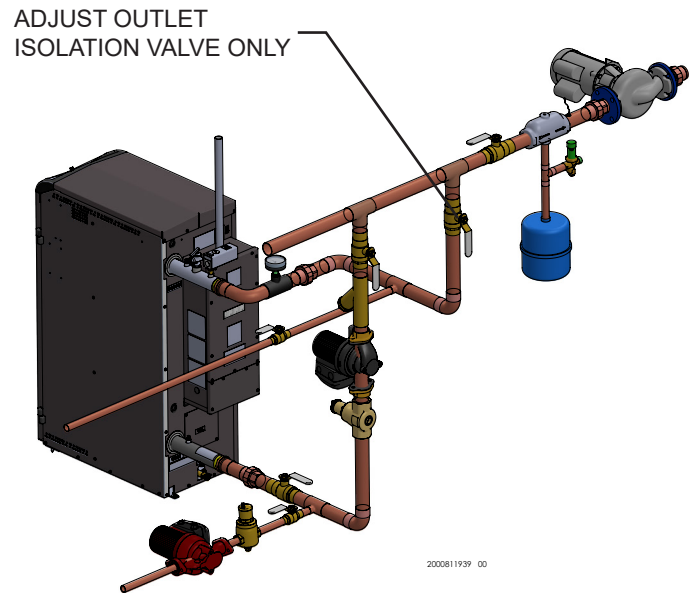

### 3 Troubleshooting

**WARNING** Label all wires prior to disconnection when servicing controls. Wiring errors can cause improper and dangerous operation. Always disconnect power to the boiler before servicing. Failure to comply could result in severe personal injury, death, or substantial property damage.

**WARNING** Never jumper (bypass) any device except for momentary testing as outlined in the Troubleshooting chart. Severe personal injury, death, or substantial property damage can result.

#### Before troubleshooting:

1. Have the following items:
  - a. Voltmeter that can check 120VAC to 600VAC, CAT IV 600V, 24VAC and 24VDC
  - b. Continuity checker.
  - c. Contact thermometer.
  - d. Necessary PPE
2. Check for rated voltage (either 208/240/480/600VAC), then check for 120VAC inside the unit at the controls on the main transformer's secondary side.
3. Make sure thermostat is calling for heat and contacts (including appropriate zone controls) are closed. Check for 24 VDC between thermostat wire nuts and ground.
4. Make sure all external limit controls are installed and operating.

#### Check the following:

1. Wire connectors to control module are securely plugged in at the module and originating control.

#### Check control module fuses

**NOTICE** ALWAYS check control module fuses before replacing control module or any major components. If one of these fuses is blown, it can prevent the control module or other components from operating.

1. Turn OFF the power to the boiler at the external line switch.
2. Remove front access cover.
3. Inspect fuses F1, F2, and F3, see FIG 3-1 below.

**Figure 3-1 Control Module Fuses**

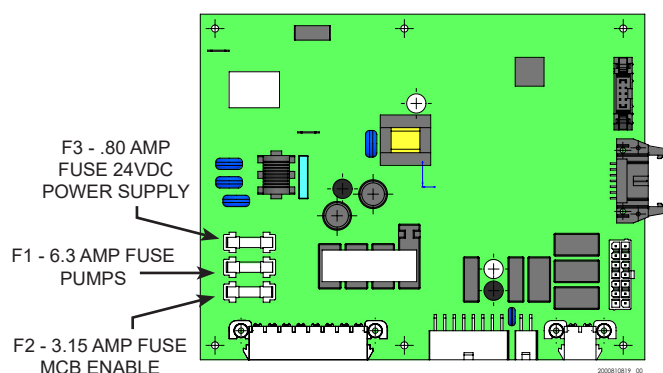

4. The boiler is shipped with three (3) spare fuses in a plastic bag inside the documentation package.
5. If necessary, replace open fuse (F3 is .80 amps, F2 is 3.15 amps and F1 is 5 amps).

**Note:** Fuses F1, F2, and F3 are all slow blow fuses.

**WARNING** Do not jumper fuse or replace with any fuse except as specified. Failure to comply could result in severe personal injury, death, or substantial property damage.

6. Install the front access cover after fuse inspection.
7. Restore power to the boiler at the external line switch and verify boiler operation (Section 5 - Start-up in the Lectrus Installation and Operation Manual) after completing boiler service.

#### Check appliance fuses

**WARNING** Make sure the appliance power is disabled prior working with the appliance fuses. Failure to comply could result in severe personal injury, death, or substantial property damage.

1. Make sure the power from the main appliance is disabled.
2. Unlock the front door of the unit.
3. Visually inspect for potential burns or electric failure.
4. Make sure the voltage is not present at the fuse.
5. Using the appropriate tool verify each fuse. If necessary, replace open fuses using a replacement component of the same size. Refer to table 3-1 on the following page.
6. Make sure all circuits have their fuses installed.
7. Close and lock the front door of the unit.
8. Restore power to the boiler and verify the boiler operation. Refer to Section 5 - Startup of the Installation and Operation manual.

### 3 Troubleshooting

**Table 3-1** Fuse replacement chart

Lectrus Model	Voltage	Power	Lochinvar Part number
KEB0015-A	240VAC	15kW	100146025
KEB0015-A	240VAC	30kW	
KEB0015-K	208VAC 3 Phase	15KW	100146031
KEB0030-K	208VAC 3 Phase	30KW	
KEB0045-K	208VAC 3 Phase	45KW	
KEB0060-K	208VAC 3 Phase	60KW	
KEB0075-K	208VAC 3 Phase	75KW	
KEB0090-K	208VAC 3 Phase	90KW	
KEB0105-K	208VAC 3 Phase	105KW	
KEB0120-K	208VAC 3 Phase	120KW	
KEB0120-K	208VAC 3 Phase	135KW	
KEB0150-K	208VAC 3 Phase	150KW	
KEB0015-X	480VAC 3 Phase	15KW	
KEB0030-X	480VAC 3 Phase	30KW	
KEB0045-X	480VAC 3 Phase	45KW	
KEB0060-X	480VAC 3 Phase	60KW	
KEB0075-X	480VAC 3 Phase	75KW	
KEB0090-X	480VAC 3 Phase	90KW	
KEB0105-X	480VAC 3 Phase	105KW	100146030
KEB0120-X	480VAC 3 Phase	120KW	
KEB0120-X	480VAC 3 Phase	135KW	
KEB0150-X	480VAC 3 Phase	150KW	
KEB0015-N	600VAC 3 Phase	15KW	
KEB0030-N	600VAC 3 Phase	30KW	
KEB0045-N	600VAC 3 Phase	45KW	
KEB0060-N	600VAC 3 Phase	60KW	
KEB0075-N	600VAC 3 Phase	75KW	
KEB0090-N	600VAC 3 Phase	90KW	
KEB0105-N	600VAC 3 Phase	105KW	100146022
KEB0120-N	600VAC 3 Phase	120KW	
KEB0120-N	600VAC 3 Phase	135KW	
KEB0150-N	600VAC 3 Phase	150KW	

### 3 Troubleshooting

Table 3-2 Troubleshooting Chart - No Display

FAULT	CAUSE	CORRECTIVE ACTION
<b>No Display</b>	- No power supplied to unit.	<ul style="list-style-type: none"> <li>• Check external line switch, fuse, or breaker.</li> <li>• Check position of ON/OFF switch. Turn switch to the ON position.</li> <li>• Check for 120VAC across the ON/OFF switch.</li> <li>• Check wiring harness connection between display board and the boiler integrated control (BIC). Connect harness at both points.</li> <li>• If equipped with an optional Control Enable/Disable E-stop button, check that the push button is re-armed.</li> </ul>
	- No voltage through the switch.	• Replace switch.
	- Bad display board.	• Replace board.
	- Bad boiler integrated control (BIC).	• Replace the boiler integrated control (BIC).
	- Blown fuse.	• Replace fuse F3 on the boiler integrated control (BIC), see page 37 of this manual.
<b>No Operation</b>	- Boiler integrated control (BIC) temperature set point satisfied.	• Review temperature setting.
	- Remote thermostat satisfied.	• Review remote thermostat setting.
	- Outside air temperature above Warm Weather Shutdown (WWSD) set point for the boiler integrated control (BIC).	• Check location of outside air sensor. Check resistance of outdoor air sensor and compare to Table 3-2B on page 38 of this manual.
	- Unit locked out on fault.	• Consult display for specific fault. Refer to fault descriptions on page 40 of this manual for corrective actions.
	- Unit in Shutdown Mode.	• Take unit out of Shutdown Mode.
<b>Unit Does Not Modulate Above 50%</b>	- Ramp delay active.	• Check ramp delay parameter settings.
		• Turn ramp delay feature off. See page 25 of this manual for instructions on how to turn this feature off.
	- Boiler controlled by BMS.	• Check BMS parameter settings.

### 3 Troubleshooting *(continued)*

#### Checking temperature sensors

The boiler temperature sensors (inlet water, outlet water, system water, and outdoor air) are all resistance type devices. The following tables show the correct values for the sensors at various temperatures. Use an ohmmeter to read the resistance of the sensor at a known temperature. If the resistance of the sensor does not closely match its corresponding table, replace the sensor.

It is important to note that the outlet water sensors have two temperature sensing devices in one housing. These devices are designated as S1a/S1b and outlet sensor. Please reference the wiring diagram in the Lectrus Installation and Operation Manual for correct terminal location.

**Table 3-3A - Inlet Water/System Sensor Resistance vs. Temperature**

Temperature	Resistance	Temperature	Resistance
50	18,780	158	1,990
68	12,263	176	1,458
86	8,194	194	1,084
104	5,592	212	817
122	3,893		
140	2,760		

**Table 3-3B - Outdoor Air Sensor Resistance vs. Temperature**

Temperature	Resistance	Temperature	Resistance
-50	490,813	20	46,218
-40	336,606	30	34,558
-30	234,196	40	26,099
-20	165,180	50	19,900
10	118,018	60	15,311
0	85,362	70	11,883
10	62,465	80	9,299

**Table 3-3C - Outlet Water Sensor Resistance vs. Temperature**

<b>S1a</b> (Wire Color - R/BK and Blue)				<b>S1b</b> (Wire Color - R/BK and Blue)			
Temperature	Resistance	Temperature	Resistance	Temperature	Resistance	Temperature	Resistance
50	19,553	158	2,004	50	40,030	158	3,478
68	12,690	176	1,464	68	25,030	176	2,492
86	8,406	194	1,084	86	16,090	194	1,816
104	5,715	212	816	104	10,610	212	1,344
122	3,958			122	7,166		
140	2,786			140	4,943		

### 3 Troubleshooting

Table 3-4 Troubleshooting Chart

FAULT	DESCRIPTION	CORRECTIVE ACTION
<b>Noisy Operation</b>	- Low water flow through the unit.	<ul style="list-style-type: none"> <li>Refer to Section 3 - Hydronic Piping of the Lectrus Installation and Operation Manual for minimum flow rates. Verify that the boiler and system pump are running on a call for heat.</li> </ul>
	- Air in the piping system.	<ul style="list-style-type: none"> <li>Properly purge all air from the piping system.</li> </ul>
	- Low system water pressure.	<ul style="list-style-type: none"> <li>Verify system pressure is a minimum of 12 psi.</li> </ul>
<b>No Pump Operation - Boiler Pump System Pump or DHW Pump</b>	- Blown fuse.	<ul style="list-style-type: none"> <li>Replace fuse F1 on the control board, see page 36 of this manual.</li> </ul> <p><b>Note:</b> Make sure pump amperage does not exceed 1.8 amps.</p>
	- Faulty pump.	<ul style="list-style-type: none"> <li>Replace pump.</li> </ul>
	- Internal fault on control board.	<ul style="list-style-type: none"> <li>Replace boiler integrated control (BIC).</li> </ul>
<b>Relief Valve Opening</b>	- System pressure exceeds relief valve setting.	<ul style="list-style-type: none"> <li>Lower the system pressure below the 30 psi rating of the supplied relief valve or replace the standard relief valve with a higher rated valve up to the maximum pressure of the heat exchanger.</li> <li>Improperly sized expansion tank.</li> </ul>
<b>(98) MRHL/LWCO</b> (will require a manual reset once condition has been corrected. Press the RESET button on the SMART SYSTEM display to reset.)	- Either the external manual reset high limit (MRHL) or the low water cutoff (LWCO) is not making.	<ul style="list-style-type: none"> <li>Check boiler pump operation on a call for heat.</li> <li>Check for closed valves or obstructions in the boiler piping.</li> <li>Verify system is full of water and all air has been purged from the system.</li> <li>Check for a loose or misplaced jumper if flow switch is not installed.</li> <li>Replace LWCO.</li> <li>Verify the transformer for the LWCO provides a 24VAC when there is a call for heat.</li> </ul>
	- Blown fuse.	<ul style="list-style-type: none"> <li>Replace fuse F3 on the control board, see page 36 of this manual.</li> </ul>
<b>Too Many Recyclings</b>	One or more limit switches has opened more than five (5) times during the last call for heat.	<ul style="list-style-type: none"> <li>Check harness connections at the control board and low voltage connection board.</li> </ul>
<b>Anti-cycling</b>	The unit recently turned off.	<ul style="list-style-type: none"> <li>The control board will release the call for heat after a set time period.</li> <li>The control board will release the call for heat if the outlet temperature drops too quickly.</li> </ul>

### 3 Troubleshooting *(continued)*

**Table 3-5 Troubleshooting Chart - Fault Messages Displayed on Boiler Interface**

FAULT	DESCRIPTION	CORRECTIVE ACTION
<p><b>(97)</b> <b>Outlet ARHL</b></p>	<p>The outlet water temperature has exceeded the setting of the automatic reset high limit.</p>	<ul style="list-style-type: none"> <li>• Adjust the set point of the auto reset limit to a higher setting up to a maximum of 225°F. Reference this manual for information on adjusting the temperature settings.</li> <li>• Verify that the system is full of water and that all air has been properly purged from the system.</li> <li>• Verify that the boiler is piped properly into the heating system. Refer to Section 3 - Hydronic Piping of the Lectrus Installation and Operation Manual for the proper piping methods for the Lectrus boiler.</li> <li>• Check 120 vac to boiler pump motor on a call for heat. If voltage is not present, check wiring back to the boiler integrated control (BIC).</li> <li>• If 120 vac is present on a call for heat and the boiler pump is not operating, replace the pump.</li> <li>• If the system pump is a variable speed pump, ensure that the system flow is not less than the boiler flow.</li> <li>• If operating on something other than an outlet sensor, check temperature setting of the boiler integrated control (BIC).</li> <li>• Check resistance of water sensors and compare to Table 3-3A on page 38 of this manual. Replace sensor if necessary.</li> <li>• Replace the boiler integrated control (BIC) if necessary.</li> </ul>
<p><b>(106)</b> <b>Outlet MRHL</b> (will require a manual reset once the condition has been corrected. Press the RESET button on the SMART SYSTEM display to reset.)</p>	<p>The outlet water temperature has exceeded the setting of the manual reset high limit.</p>	<ul style="list-style-type: none"> <li>• Adjust the set point of the manual reset limit to a higher setting up to a maximum of 230°F. Reference this manual for information on adjusting the temperature settings.</li> <li>• Verify that the system is full of water and that all air has been properly purged from the system.</li> <li>• Verify that the boiler is piped properly into the heating system. Refer to Section 3 - Hydronic Piping of the Lectrus Installation and Operation Manual for the proper piping methods for the Lectrus boiler.</li> <li>• Check 120 vac to boiler pump motor on a call for heat. If voltage is not present, check wiring back to the boiler integrated control (BIC).</li> </ul>

### 3 Troubleshooting

**Table 3-5** (continued from previous page) *Troubleshooting Chart - Fault Messages Displayed on Boiler Interface*

FAULT	DESCRIPTION	CORRECTIVE ACTION
<p><b>Outlet MRHL (cont'd)</b> (will require a manual reset once the condition has been corrected. Press the RESET button on the SMART SYSTEM display to reset.)</p>	<p>The outlet water temperature has exceeded the setting of the manual reset high limit.</p>	<ul style="list-style-type: none"> <li>• If 120 vac is present on a call for heat and the boiler pump is not operating, replace the pump.</li> <li>• If the system pump is a variable speed pump, ensure that the system flow is not less than the boiler flow.</li> <li>• If operating on something other than an outlet sensor, check temperature setting of the boiler integrated control (BIC).</li> <li>• Check resistance of water sensors and compare to Table 3-2A on page 38 of this manual. Replace sensor if necessary.</li> <li>• Replace the boiler integrated control (BIC) if necessary.</li> </ul>
<p><b>(54/55) Inlet Fault</b> (will require a manual reset once the condition has been corrected. Press the RESET button on the SMART SYSTEM display to reset.)</p>	<p>The inlet water temperature sensor has been disconnected or shorted.</p>	<ul style="list-style-type: none"> <li>• Check the sensors and their associated wiring. Repair or replace the sensor or wiring if damaged.</li> <li>• Measure the resistance of the sensors and compare the resistance to the tables on page 39 of this manual.</li> <li>• Replace the sensor if necessary.</li> </ul>
<p><b>(112) Outlet Fault</b> (will require a manual reset once the condition has been corrected. Press the RESET button on the SMART SYSTEM display to reset.)</p>	<p>The outlet water temperature sensor has been disconnected or shorted.</p>	<ul style="list-style-type: none"> <li>• Check the sensors and their associated wiring. Repair or replace the sensor or wiring if damaged.</li> <li>• Measure the resistance of the sensors and compare the resistance to the tables on page 39 of this manual.</li> <li>• Replace the sensor if necessary.</li> </ul>
<p><b>(109) Outlet Temp Diff</b> (will require a manual reset once the condition has been corrected. Press the RESET button on the SMART SYSTEM display to reset.)</p>	<p>The temperature difference between the two (2) outlet sensors is too high.</p>	<ul style="list-style-type: none"> <li>• Check wiring to sensor. Make sure wiring is connected and not damaged. Reconnect / repair wiring if necessary.</li> <li>• Measure the resistance of the sensor and compare to the resistance in Table 3-2C on page 39 of this manual. Replace sensor if necessary.</li> <li>• Replace control module.</li> </ul>
<p><b>Fatal Error</b></p>	<p>The control module has detected parameter settings that are corrupted.</p>	<ul style="list-style-type: none"> <li>• Replace control module.</li> </ul>
<p><b>Memory Error</b></p>	<p>A lockout occurs at the same time as a power outage.</p>	<ul style="list-style-type: none"> <li>• Reset control module.</li> </ul>

### 3 Troubleshooting *(continued)*

**Table 3-5** (continued from previous page) *Troubleshooting Chart - Fault Messages Displayed on Boiler Interface*

FAULT	DESCRIPTION	CORRECTIVE ACTION
<b>Delta T High</b>	The temperature rise across the unit has exceeded the set parameters for the boiler.	<ul style="list-style-type: none"> <li>• Verify that the system is full of water and that all air has been properly purged from the system.</li> <li>• Verify that the boiler is piped properly into the heating system. Refer to Section 3 - Hydronic Piping of the Lectrus Installation and Operation Manual for the proper piping methods for the Lectrus boiler.</li> <li>• Check for 120 vac to the boiler pump motor on a call for heat. If voltage is not present, check the wiring back to the boiler integrated control (BIC). Replace the boiler integrated control (BIC) if necessary.</li> <li>• If 120 vac is present on a call for heat and the boiler pump is not operating, replace the pump.</li> <li>• Verify that the boiler pump is set to the proper speed or that the pump is the proper size. Reference Section 3 - Hydronic Piping of the Lectrus Installation and Operation Manual for boiler pump specifications.</li> </ul>
<b>Outlet Temp High</b>	Outlet water temperature has exceeded the maximum outlet water temperature.	<ul style="list-style-type: none"> <li>• Verify that the system is full of water and that all air has been properly purged from the system.</li> <li>• Verify that the boiler is piped properly into the heating system. Refer to Section 3 - Hydronic Piping of the Lectrus Installation and Operation Manual for the proper piping methods for the Lectrus boiler.</li> <li>• Check for 120 vac to the boiler pump motor on a call for heat. If voltage is not present, check wiring back to the boiler integrated control (BIC). Replace the boiler integrated control (BIC) if necessary.</li> <li>• If 120 vac is present on a call for heat and the boiler pump is not operating, replace the pump.</li> <li>• Verify that the boiler pump is set to the proper speed or that the boiler pump is the proper size. Reference Section 3 - Hydronic Piping of the Lectrus Installation and Operation Manual for boiler pump specifications.</li> <li>• Replace the boiler integrated control (BIC).</li> </ul>
<b>Low 24 VDC</b>	The power supply unit output voltage is going lower than expected.	<ul style="list-style-type: none"> <li>• Check 120 vac supply to the power supply unit.</li> <li>• Check wiring connections at the low voltage terminal strip.</li> <li>• Check the wire size/length to remote devices.</li> <li>• Replace the power supply.</li> </ul>
<b>Watch Dog Error</b>	The boiler integrated control (BIC) has detected an internal fault.	<ul style="list-style-type: none"> <li>• Cycle power to the boiler.</li> <li>• Replace the boiler integrated control (BIC).</li> </ul>
<b>Write EEPROM</b>	The boiler integrated control (BIC) has detected an internal fault.	<ul style="list-style-type: none"> <li>• Cycle power to the boiler.</li> <li>• Replace the boiler integrated control (BIC).</li> </ul>

### 3 Troubleshooting

**Table 3-5** (continued from previous page) *Troubleshooting Chart - Fault Messages Displayed on Boiler Interface*

<b>FAULT</b>	<b>DESCRIPTION</b>	<b>CORRECTIVE ACTION</b>
<b>CRC Parameters</b>	The boiler integrated control (BIC) has detected an internal fault.	<ul style="list-style-type: none"> <li>• Cycle power to the boiler.</li> <li>• Replace the boiler integrated control (BIC).</li> </ul>
<b>No Error Stored</b>	The particular lockout information has been lost.	<ul style="list-style-type: none"> <li>• Press the RESET button.</li> <li>• Replace the boiler integrated control (BIC).</li> </ul>
<b>(52) ELWCO</b>	The external low water cutoff has tripped.	<ul style="list-style-type: none"> <li>• Reset the external water cutoff.</li> <li>• If not present, make sure the input is shorted on the connection board.</li> </ul>
<b>(53) Monitor</b>	The contactor relay is not in the correct state.	<ul style="list-style-type: none"> <li>• Make sure the relay is correctly installed.</li> <li>• Check primary safeties under fault number (98) and (100)</li> <li>• Power cycle the boiler.</li> <li>• Replace the relay.</li> </ul>
<b>(100) Flow switch</b>	There is no flow.	<ul style="list-style-type: none"> <li>• Make sure the pumps are working.</li> <li>• Make sure the flow switch is present and properly connected, if not present, make sure the input in the connector board is shorted.</li> <li>• Power cycle the boiler.</li> <li>• Replace the boiler integrated control (BIC).</li> </ul>
<b>(101) Water Press</b>	The water pressure is incorrect.	<ul style="list-style-type: none"> <li>• Make sure the sensor is properly connected. Short the sensor to verify that the unit is working correctly. If that fixes the issue, replace the sensor.</li> <li>• If not present, make sure the input is shorted on the connector board.</li> <li>• Make sure the pump is running.</li> <li>• Power cycle the boiler.</li> <li>• Replace the boiler integrated control (BIC).</li> </ul>
<b>(50) MCB Warning</b>	The Modulating Control Board (MCB) is in lockout fault.	<ul style="list-style-type: none"> <li>• Refer to table 3-6</li> </ul>

### 3 Troubleshooting *(continued)*

**Table 3-6** Troubleshooting Chart - Check Modulating Control Board (MCB) Status

LED STATUS			FAULT	DESCRIPTION	CORRECTIVE ACTION
BLUE	ORANGE	YELLOW			
OFF	OFF	OFF	None	No fault – Unit running normally	<ul style="list-style-type: none"> <li>None</li> </ul>
OFF	OFF	ON	Fan	The fan for the triac has a tachometer error	<ul style="list-style-type: none"> <li>Make sure the fan is connected in the triac board.</li> <li>Verify the fan is running when there is a demand for heat.</li> <li>Replace the fan.</li> </ul>
OFF	ON	OFF	Pressure	Pressure in the system is too high or outside limit	<ul style="list-style-type: none"> <li>Check the pressure of the system.</li> </ul>
OFF	BLINK	OFF	Pressure	Pressure in the system is too low	<ul style="list-style-type: none"> <li>Verify that the pressure is at least 12 PSI.</li> </ul>
OFF	ON	ON	Unbalance	Current between lines is unbalanced	<ul style="list-style-type: none"> <li>If equipped, the monitoring of the line is detecting an unbalance between phases. Check for a damaged element.</li> <li>Check for blown fuses.</li> </ul>
ON	OFF	OFF	Power	Input voltage of the 24VDC is too low	<ul style="list-style-type: none"> <li>Verify the PSU is providing 24VDC.</li> <li>Make sure the connections to the MCB are secure.</li> <li>Replace the MCB.</li> </ul>
ON	ON	ON	Address	Address of the MCB is incorrect	<ul style="list-style-type: none"> <li>Make sure the main MCB is set as address 0 (all address switch S2 OFF).</li> <li>If equipped, make sure additional MCB's don't have duplicated addresses on S2.</li> <li>Make sure the communication cable between MCB's is good and not damaged. Replace the MCB.</li> </ul>
BLINK	OFF	OFF	Input voltage	The internal voltage of the MCB is detecting an error	<ul style="list-style-type: none"> <li>Replace the MCB.</li> </ul>
BLINK	ON	OFF	Line current	The line current is too low	<ul style="list-style-type: none"> <li>If equipped, the monitoring of the line is too low for the power requested.</li> <li>Check elements for any damage.</li> <li>Verify that the contactors are activating.</li> <li>Verify that the fuses are in good condition.</li> </ul>

### 3 Troubleshooting

**Table 3-6 Troubleshooting Chart - Check MCB Status (continued from previous page)**

LED STATUS			FAULT	DESCRIPTION	CORRECTIVE ACTION
BLUE	ORANGE	YELLOW			
OFF	BLINK	BLINK	Zero cross	The zero-crossing detection is in fault	<ul style="list-style-type: none"> <li>• Check elements for any damage.</li> <li>• Verify that the contactors are activating.</li> <li>• Verify that the fuses are in good condition.</li> <li>• Check lockout history as safety trips can cause zero crossing errors.</li> <li>• Cycle 120V power to the boiler via the power switch on the back of the unit.</li> <li>• Replace the MCB.</li> </ul>
BLINK	BLINK	OFF	PWM error	The MCB is receiving a message from the boiler control that is incorrect	<ul style="list-style-type: none"> <li>• Check the BIC for any damage.</li> <li>• Check the cable between the BIC and MCB for any damage.</li> <li>• Check the MCB for any damage.</li> <li>• Cycle 120V power to the boiler via the power switch on the back of the unit.</li> <li>• Replace MCB.</li> <li>• Replace BIC.</li> </ul>

**NOTE:** The GREEN LED indicates this:

OFF - no power to control.

FLASHING - off/on is normal operation.

STAYS ON - Control encountered a power supply problem and has locked itself out to prevent damage -

CYCLE power to verify problem goes away.

## 3 Troubleshooting *(continued)*

### Utility dual-energy connection

If the utility requires a dual energy connection for the boiler, an external assembly is present in the boiler to achieve this feature. The dual-energy installation is made to provide alternate source of energy when the electric heating is not permitted by the utility. Usually, the second source of energy is fossil fuel (natural gas or propane). The utility company is providing a normally open and closed contact up to 30V at 500mA.

The external box provided with the Lectrus boiler needs to be connected using the Connection board on the back of the unit:

**Table 3-7** Connections from the Connection Board to Lectrus

CONNECTION BOARD	LECTRUS UTILITY CONNECTION BOX
Alarm Power (CN1/1)	Alarm Power (CN1/1)
Alarm Power (CN1/2)	Alarm Power (CN1/2)
Alarm (CN3-2/7)	Alarm Contact for boiler (CN3-2/7)
Alarm (CN3-2/8)	Alarm Contact for boiler (CN3-2/8)
Demand Enable (CN3-2/1)	Demand Enable IN (CN3-2/1)
Demand Enable (CN3-2/2)	Demand Enable IN (CN3-2/2)
Cascade A (CN2/6)	Cascade (A in)

Connection from the external box to signal outside the boiler:

**Table 3-8** Connections from the external box to Lectrus

OTHER CONNECTION	LECTRUS UTILITY CONNECTION BOX
To the next boiler unit in cascade A	Cascade (A out)
Auxiliary boilers enable Contact 1	Aux Boiler Enable (N/O)
Auxiliary boilers enable Contact 2	Aux Boiler Enable (COM)
Normally open contact from utility	Bi-Energy Contact (N/O)
Common contact from utility	Bi-Energy Contact (COM)
Enable signal from thermostat or BMS or other	Demand Enable IN
Enable signal from thermostat or BMS or other	Demand Enable IN
To the redundant leader in the cascade	Gas Unit Enable OUT
To the redundant leader in the cascade	Gas Unit Enable OUT

With the Lectrus boiler installed as the leader of the cascade, the unit will be the first to start when there is a heat demand. If the electric boiler can satisfy the demand, no other unit will be enabled. If there is not enough power to satisfy the demand, the Lectrus boiler will enable the next unit in the cascade to help. When the utility is requesting not to run electric, the Lectrus boiler will stay out of the demand and wait to be enabled by the utility. During this time the other units will be enabled and run to satisfy the heat demand. Only one Lectrus unit will be able to be controlled by this installation.

If the Dual-Energy doesn't work,

1. Verify if the wiring is per the tables 3-7 and 3-8.
2. Validate that the wiring in the box doesn't have any loose wires.
3. Check the relays for damage and if possible, verify the functionality of the relays.
4. Replace the box.

---

# NOTES

---

# NOTES

---

# NOTES

**Revision Notes:** *Revision A (PCP #3000060390 / CN #500046379) initial release.*

*Revision B (PCP #3000061447 / CN #500047320) reflects updates to the table of contents and table 3-6.*

*Revision C (PCP #3000061070 / CN #500046969) reflects the addition of LWCO information on page 10.*

*Revision D (PCP #3000063264 / CN #500049042) reflects updates to table 1-4.*

*Revision E (PCP #3000064224 / CN #500050050) reflects additional information in section 1, and updates throughout.*