

# ON-DEMAND RACK SYSTEM

## INSTALLATION MANUAL

FREE STANDING  
(BACK-TO-BACK)

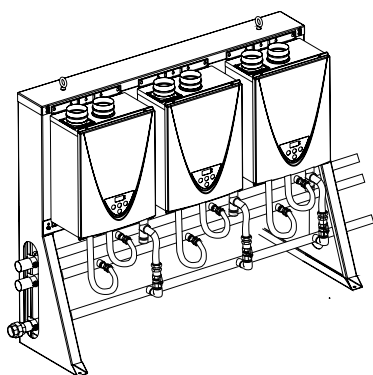
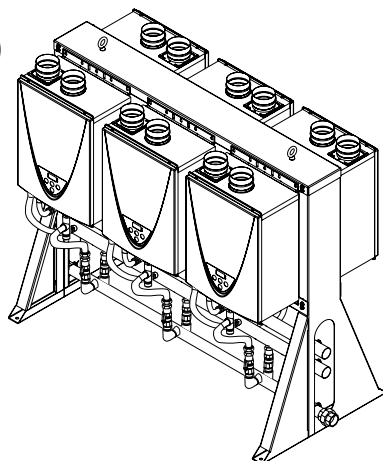

FREE STANDING  
(IN-LINE)

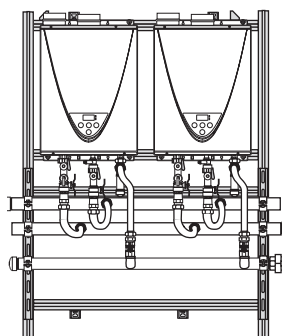

WALL MOUNT

ADDITIONAL INFORMATION IS PROVIDED IN THE WATER HEATER'S INSTALLATION MANUAL AND OWNER'S GUIDE. A COPY IS PROVIDED WITH EACH WATER HEATER IN THE ASSEMBLY.

**WARNING:** If the information in these instructions is not followed exactly, a fire or explosion may result causing property damage, personal injury or death.

Do not store or use gasoline or other flammable vapors and liquids in the vicinity of this or any other appliance.

### WHAT TO DO IF YOU SMELL GAS

- Do not try to light any appliance.
  - Do not touch any electrical switch; do not use any phone in your building.
  - Immediately call your gas supplier from a neighbor's phone. Follow the gas supplier's instructions.
  - If you cannot reach your gas supplier, call the fire department.
- Installation and service must be performed by a qualified installer, service agency or the gas supplier.

## Table of Contents Page

## Page





Important Safety Information.....	2
Getting Started .....	3
Installation.....	4
Maintenance .....	10
Specifications: Wall Mount (42" Frame Width).....	12
Specifications: Wall Mount (62.81" Frame Width) .....	14
Specifications: Free Standing (41.54" Frame Width).....	16
Specifications: Free Standing (62.29" Frame Width).....	18
Replacement Parts .....	20

**INSTALLATION MUST BE PERFORMED BY QUALIFIED SERVICE PROFESSIONALS ONLY.**

# IMPORTANT SAFETY INFORMATION

Read and follow all safety messages and instructions in this manual.

	<p>This is the safety alert symbol. It is used to alert you to potential physical injury hazards. Obey all safety messages that follow this symbol to avoid possible property damage, serious injury or death. Do not remove any permanent instructions, labels, or the data plate from either the outside of the water heater or on the inside of the access panels. Keep this manual near the water heater.</p>
---	---

	<p><b>DANGER</b> indicates hazardous situation that, if not avoided, will result in death or serious injury.</p>
	<p><b>WARNING</b> indicates a hazardous situation that, if not avoided, could result in death or serious injury.</p>
	<p><b>CAUTION</b> indicates a hazardous situation that, if not avoided, could result in minor or moderate injury.</p>
	<p><b>NOTICE</b> indicates practices not related to physical injury.</p>

**▲ WARNING!** If the information in these instructions is not followed exactly, a fire or explosion may result causing property damage, personal injury or death. Do not store or use gasoline or other flammable vapors and liquids in the vicinity of this or any other appliance.

An odorant is added by the gas supplier to the gas used by this water heater. This odorant may fade over an extended period of time. Do not depend upon this odorant as an indication of leaking gas. We recommend installing a fuel gas and carbon monoxide detector.

Installation includes the connection of gas lines, water lines, valves and electricity. Knowledge of applicable national, state, and local codes is necessary. Therefore, installation must be performed only by qualified service professionals.

Read and follow all instructions, cautions, and warnings in the water heaters' Installation Manuals/Owner's Guides.

## **⚠ WARNING**

Follow all local codes during installation. In the absence of local codes, follow the National Fuel Gas Code, ANSI Z223.1/NFPA 54 (current edition) in the USA, or in Canada, follow CAN/CSA B149.1, Natural Gas and Propane Installation Code (current edition). Failure to do so may cause death, personal injury, or property damage.

## Product Registration

The rack system itself does not require registration. However, each water heater within the system should be registered. To do so, fill out and return the registration card for each water heater. (Each water heater is provided with its own manual and registration card.) Alternatively, you may register through the website listed on the registration card.

## General Information

The On-Demand Rack System includes both wall-mounted and free standing configurations, and several options are available within each type. Refer to the *Specifications* section.

For questions regarding general operation, refer to the water heaters' manuals.

## Venting

Venting components are not supplied with the rack system and must be obtained separately. For venting instructions, refer to the water heaters' installation manuals/owner's guides.

## Installation Requirements

- Observe the water heaters' installation requirements as outlined in their installation manual.
- Installation and service must be performed by a qualified service professional, such as a licensed plumber or gas fitter. Otherwise, the warranty will be void.
- The installer is responsible for the correct installation of the water heater and for compliance with all code requirements.
- Place the water heaters in a location that provides easy access for service and maintenance.
- Do not install the system in a pit or location where gas and water can accumulate.
- Do not allow the vent terminals to point toward any operating window, door, or opening into a building.
- Do not install the system next to any source of airborne debris that can cause debris to be trapped inside the combustion chambers (unless the system is direct vented).
- The power supply must be 120 VAC (60 Hz) and must be properly grounded.

### Indoor Models

- Do not install indoor models outdoors.
- Due to safety concerns, attic installations are not recommended. If you install the system in an attic:
  - Make sure the water heaters will have enough combustion air and proper ventilation. Refer to the installation manual for the water heaters.

- Keep the area around the water heaters clean. When dust collects on the flame sensors, the water heaters will shut down and produce an error code.
- A drain pan, or other means of protection against water damage, is required to be installed under the water heaters in case of leaks.
- It is recommended to direct vent the water heaters.
- Ensure that the surrounding areas are protected from potential water damage (i.e., condensate discharge, etc.). In the absence of local codes and regulations, it is recommended that condensate be disposed of in a standard drain.

### Outdoor Models

- Do not install outdoor models indoors.
- Outdoor models must be installed only in an area with a mild, temperate climate. Also, refer to the water heaters' manual for freeze protection information.
- Ensure that the installation is in an open, unroofed area with minimum clearances observed.
- Ensure that the surrounding areas are protected from potential water damage (i.e., condensate discharge, etc.). In the absence of local codes and regulations, it is recommended that condensate be disposed of in a standard drain.

# INSTALLATION

## 1 Install the Rack(s)

When installing the rack(s), you must comply with the water heaters' installation requirements. Refer to the *Installation Manual and Owner's Guide*.

See also *Installation Requirements* on page 7.

- **▲ WARNING! The floor or wall must be able to support the rack system in a secure and safe manner. Follow local and state code requirements. Failure to do so can lead to loss of life, personal injury, and/or property damage.**
  - Areas prone to earthquakes may have additional code requirements. Prior to installation, contact the local authority having jurisdiction over installation requirements.
  - Ensure that you use floor/wall anchors with an adequate weight rating.
- This rack system and its water heaters must be installed according to all local and state codes or, in the absence of local and state codes, the "National Fuel Gas Code", ANSI Z223.1(NFPA 54)-current edition.
- Install the rack(s) in a location where the proper amount of combustible air will be available to it at all times without obstructions. (Refer to the water heaters' *Installation Manual and Owner's Guide*.)
- The system must be installed in a location that provides easy access for service and maintenance.
- Outdoor Systems:  
Ensure that the installation is in an open, unroofed area with minimum clearances observed.

### Wall Mounted Rack

A. Before you begin, read all warnings and bullet points at the beginning of this section.

NOTICE: Determine your installation location, then confirm that the clearance requirements are met. (Refer to the water heater manual and applicable code.)

NOTICE: Wall mount racks are shipped with lifting brackets in place. See Figure 1. These lifting

brackets are actually wall mount brackets that have been rotated 90 degrees. They will allow you to hoist the rack without the use of straps. Use a spreader lifting bar as shown in Figure 2 to ensure that the lifting force is vertical.

B. Attach the rack to the wall, and ensure that it is secure. The rack must be secured at each mounting bracket. NOTE: The mounting brackets can be moved along the channel to line up with the framing.

Figure 1: Lifting Brackets

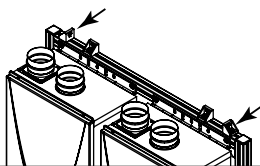

Figure 2: Spreader Lifting Bar

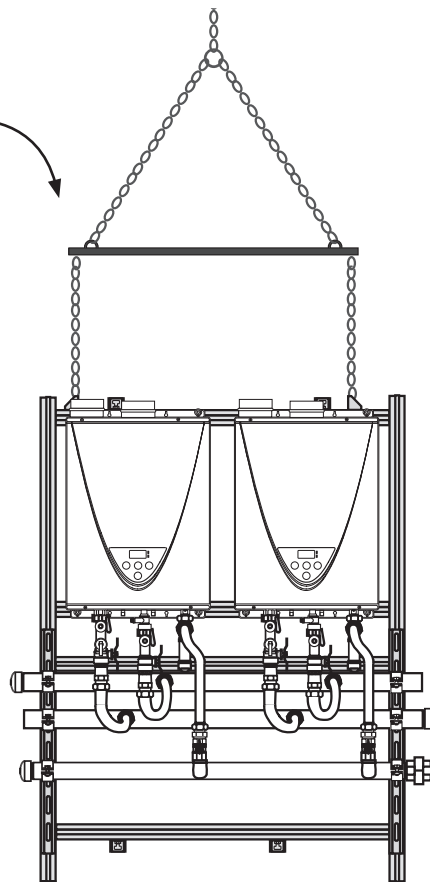
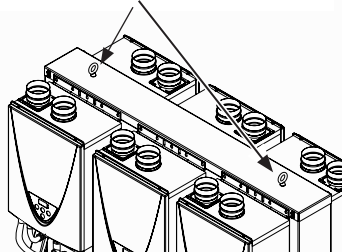

Figure 3: Lifting Eyebolts



- The clearance hole in each mounting bracket is 1/2-inch in diameter. Fasteners must be appropriate for the weight of the rack and the material to which it is being mounted. When in doubt, consult a licensed structural engineer.
- Use a leveling tool to make sure that the assembly is level. To operate properly, the assembly must be level and the water heaters must be in an upright position (as shown in Figure 4, page 6).

### Free Standing Rack

- Before you begin, read all warnings and bullet points at the beginning of this section.
- Place the rack and ensure that it is level. (The free-standing rack is equipped with lifting eyebolts. See Figure 3.)  
  
NOTICE: You may need to use straps to ensure that the lifting force is vertical.
- Verify that the clearance requirements are met. (Refer to the water heater manual and applicable code.)
- Anchor the rack to the floor at each leg. It must be secure and must not allow movement.

NOTICE: The clearance hole in each leg is 1/2-inch in diameter. Fasteners must be appropriate for the material to which the rack is being mounted. When in doubt, consult a licensed structural engineer.

### Multi-Unit Controller

If your installation includes more than four water heaters, you will need to install a multi-unit controller. See the configuration section on page 7 for more information.

### Piping Requirements

- **Piping for up to six water heaters:**  
A rack system is designed with piping to handle up to six water heaters. If the job requires four to six heaters in more than one format, then you can use two racks that provide the sum total of the required number of heaters. For example, if you needed five heaters total, you could install a rack with three heaters and another with two heaters. The water lines and gas line can be joined on site.
- **Piping for six or more water heaters:** If the job requires multiple racks that total more than six water heaters, refer to the piping diagram on page 9. Multiple rack systems require a reverse return setup to balance flows across the system. Size the hot and cold headers that supply the rack systems so that they can accommodate the water volume that is required. (These headers will be larger than the rack system piping.) The gas supply header should be sized to supply the maximum input of the total number of water heaters. Follow proper trade practices and refer to ANSI Z223.1/NFPA 54 (current edition) for proper sizing.

## 2 Install the Water Supply

Once flow direction has been determined and the inlet and outlet sides are known, cap the open end of each manifold. See Figure 4 on page 6. (Copper end caps are preferred and are field supplied. They are not included with the assembly.)

Install the water supply in reverse return format. The flow direction must preserve the “last in, first out” principle of a reverse return. See Figure 6 on page 9.

Flush the water line **at each water heater** to remove debris, then purge the air from each line. Failure to do so may cause damage to the water heaters.

## 3 Install the Pressure Relief Discharge Lines

- The discharge lines must be installed according to the water heaters’ *Installation Manual and Owner’s Guide*.
- The discharge piping for each pressure relief valve must be directed so that the hot water cannot splash on anyone or on nearby equipment.
- Attach each discharge pipe to the pressure relief valve and run the end of the tube to a maximum of 6 in. (152 mm) from the floor. This discharge tube must allow free and complete drainage without any restrictions.
- For indoor installation, a drain pan, or other means of protection against water damage, is required to be installed under the water heaters in case of leaks.

Figure 4: Cap open end of each manifold.

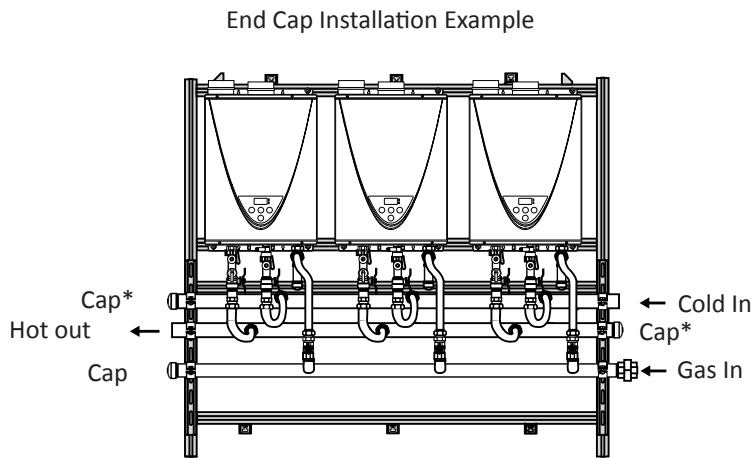

\* Copper end caps are preferred and are field supplied. They are not included with the assembly.

- Follow all applicable code requirements.

#### 4 Install the Condensate Drain Lines

Install a condensate drain line at each water heater to dispose of condensate. Refer to the water heaters' *Installation Manual and Owner's Guide* for specific instructions.

NOTICE: In the absence of local codes and regulations, it is recommended that condensate be disposed of in a standard drain.

#### 5 Install the Venting

**⚠ WARNING**

- Improper venting of this appliance can result in excessive levels of carbon monoxide which can result in severe personal injury or death.

- Improper installation can cause nausea or asphyxiation, severe injury or death from carbon monoxide and flue gases poisoning. Improper installation will void the product warranty.

Install venting according to the *Installation Manual and Owner's Guide* for the water heaters.

Follow all local codes during installation. In the absence of local codes, follow the *National Fuel Gas Code, ANSI Z223.1/NFPA 54* (current edition) in the USA, or in Canada, follow *CAN/CSA B149.1, Natural Gas and Propane Installation Code* (current edition). If you install thimbles, fire stops or other protective devices and they penetrate any combustible or noncombustible construction, be sure to follow all applicable national and local codes.

#### 6 Install the Gas Supply

- Confirm that the water heaters are rated for the type of gas that is

supplied.

- The means of gas supply must comply with local codes. In the absence of local codes, follow the *National Fuel Gas Code, ANSI Z223.1/NFPA 54* (current edition) in the USA, or in Canada, follow *CSA B149.1, Natural Gas and Propane Installation Code* (current edition).
- Ensure that the gas supply header is sized appropriately. It must be able to supply the necessary volume of gas required for the water heaters. Otherwise, flow capabilities and output temperatures will be limited. Refer to local codes, *ANSI Z223.1/NFPA 54* in the USA, or *CSA B149.1* in Canada.
- A 1-½ inch union and an end cap is supplied with each rack unit. Install these items onto the rack's piping as required. See Figure 4. Prior to operation, check for leaks and correct any that are found.
- Each water heater has its own manual gas shutoff valve already installed. Each gas supply line shall be checked for leaks using code approved methods.
- Purge the gas line of any debris and/or water before connecting to the gas inlet.
- Confirm that the gas inlet pressure is within limits.
- When the gas connections are completed, perform a gas leak test by either applying soapy water to all gas fittings and looking for bubbles or by using an electronic gas leak detection device.
- Each water heater and its individual shutoff valve must be disconnected from the gas supply piping system during any pressure testing of that

system at test pressures in excess of 1/2 psi (3.5 kPa).

- Each water heater must be isolated from the gas supply piping system by closing its manual shutoff valve during any pressure testing of that system at test pressures equal to or less than 1/2 psi (3.5 kPa).

## 7 Connect the Power Supply

- Confirm that the installation complies with local electrical code requirements. In the absence of such requirements, follow the National Electrical Code ANSI/NFPA 70 (current edition) in the U.S. or CSA C22.1 Canadian Electrical Code, Part 1 (current edition) in Canada.
- Indoor models include a factory installed, 6-foot (1.83m) long power cord.
- Outdoor models must be hard wired.

- The water heaters require 120 VAC, 60 Hz electrical power supply that is properly grounded.
- The electrical connection must provide a means of disconnection (to terminate power to the water heaters for servicing and safety purposes). Also, the water heaters must be electrically grounded. Do not attach the ground wire to either the gas or water piping. Installation must comply with all code requirements.
- Power Requirements  
One 15 amp breaker can adequately protect up to seven water heaters.  
Example:

Number of Heaters	Breaker Size (Amps)	Number of Breakers
1 to 7	15A	1
8 to 14	15A	2
15 to 20	15A	3

- Refer to the water heaters' *Installation Manual and Owner's Guide* for instructions.

## 8 Configure the System

If your rack system contains up to four water heaters, configure it with the Easy-Link System. Refer to the water heaters' *Installation Manual and Owner's Guide* for instructions.

However, if your rack system contains five or more water heaters, we strongly recommend that you install and configure a multi-unit controller (part number [100112691](#)).

- A multi-unit controller can connect up to 20 water heaters, making it easy to use multiple racks.
- The multi-unit controller is available as an accessory item. It can be ordered along with the rack system or later through your local service agency/installer.
- If a multi-unit controller is ordered with a wall mount or free standing (in-line) system, it can be installed on either end of the assembly. However, a controller-mounting kit is necessary to complete the installation. This kit is sold separately and must be installed on site by the installing contractor. (Kit part number: 100211495.) The mounting kit includes two 14-in. long mounting bars and two mounting brackets.
  - Wall mounted rack systems only: Install the bars onto either end as shown in Figure 5.
  - Free standing rack systems: The multi-unit controller may be mounted on either side of the rack or on a nearby wall. The mounting hardware must be field supplied.

See also *Piping Requirements*, p. 5.

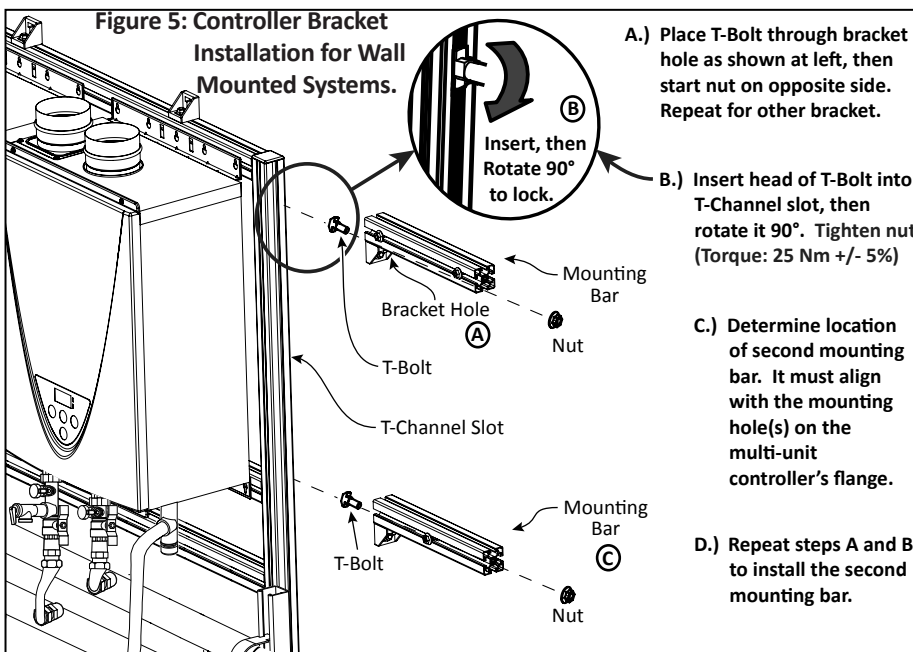

## 9 Final Installation Checklist

### ⚠ WARNING

- Do not install outdoor systems indoors.
  - Do not install indoor systems outdoors.
  - Improper installation can cause nausea or asphyxiation, severe injury or death from carbon monoxide and flue gases poisoning. Improper installation will void the product warranty.
- Power Supply:
- Confirm that the power supply is 120 VAC (60 Hz) and that the circuit is properly grounded. Refer to the *Power Requirements* table on page 7.
  - Does the electrical connection provide a means of disconnection (to terminate power to the water heaters for servicing and safety purposes)?
  - Make sure that the installation complies with local electrical code requirements. In the absence of such requirements, follow the National Electrical Code ANSI/NFPA 70 (current edition) in the U.S. or CSA C22.1 Canadian Electrical Code, Part 1 (current edition) in Canada.
- Gas Supply:
- Confirm that the water heaters are rated for the type of gas that is supplied.
  - Ensure that the gas supply line is equipped with a manual gas shut-off valve.
  - Ensure that air and debris are purged from the gas line.
  - Check the gas lines for leaks. Correct any that are found.

- Verify that the gas inlet pressure is within limits.
  - Make sure that the installation complies with all local codes. In the absence of local codes, follow the *National Fuel Gas Code*, ANSI Z223.1/NFPA 54 (current edition) in the USA, or in Canada, follow CAN/CSA B149.1, *Natural Gas and Propane Installation Code* (current edition).
- Water Supply:
- Before operation, flush the water line at each water heater to remove debris, then purge the air from each line.
  - Ensure that water hardness levels do not exceed 7 grains per gallon (120 ppm) for single family domestic applications or more than 4 grains per gallon (70 ppm) for all other types of applications. Avoid hard water scaling by proper water treatment, if necessary.
  - Ensure that no pool water, spa water, or chemically treated water is introduced into the water supply. Only potable water can be used with these water heaters. Refer to the water heaters' manuals for more information.
  - Ensure that water pH levels are between 6.5 and 8.5.
  - Is the water supply taken from a well? If so, consult with a local water quality expert before water is treated.
  - Damage caused by water quality is not covered by the warranty.
- Venting, Air Supply, and Clearances:
- Ensure that the water heaters are not subject to corrosive agents in the air. Also, ensure that the area around the water heaters is dust- and debris-free.

- Ensure that venting is installed according to the water heaters' installation manuals and the vent manufacturer's instructions.
  - Are water heater clearances observed? (Refer to the water heaters' *Installation Manual and Owner's Guide*.)
  - Are vent termination and air intake clearances observed? (Refer to the water heaters' *Installation Manual and Owner's Guide*.)
  - Verify that adequate combustion air will be available to the water heaters at all times. Refer to the water heaters' *Installation Manual and Owner's Guide*. Installation must also comply with local codes. In the absence of local codes, comply with the *National Fuel Gas Code*, ANSI Z223.1/NFPA 54 (current edition) in the USA, or in Canada, CAN/CSA B149.1, *Natural Gas and Propane Installation Code* (current edition).
- Control System:
- If your installation includes up to four water heaters, make sure that the Easy-Link System is configured properly. Refer to the water heaters' *Installation Manual and Owner's Guide* for instructions.
  - If your installation includes five or more water heaters, make sure that the multi-unit controller is installed and configured properly. (Refer to the *Multi-Unit Controller Installation Manual*.)
- When installation is complete, verify proper operation. If you have questions or need assistance, please call toll-free: 877-737-2840.

**Figure 6: Piping schematic for more than six (6) water heaters. This schematic illustrates a reverse return setup. Each rack system can comprise up to six water heaters. Note that the multi-unit controller can control up to 20 water heaters.**

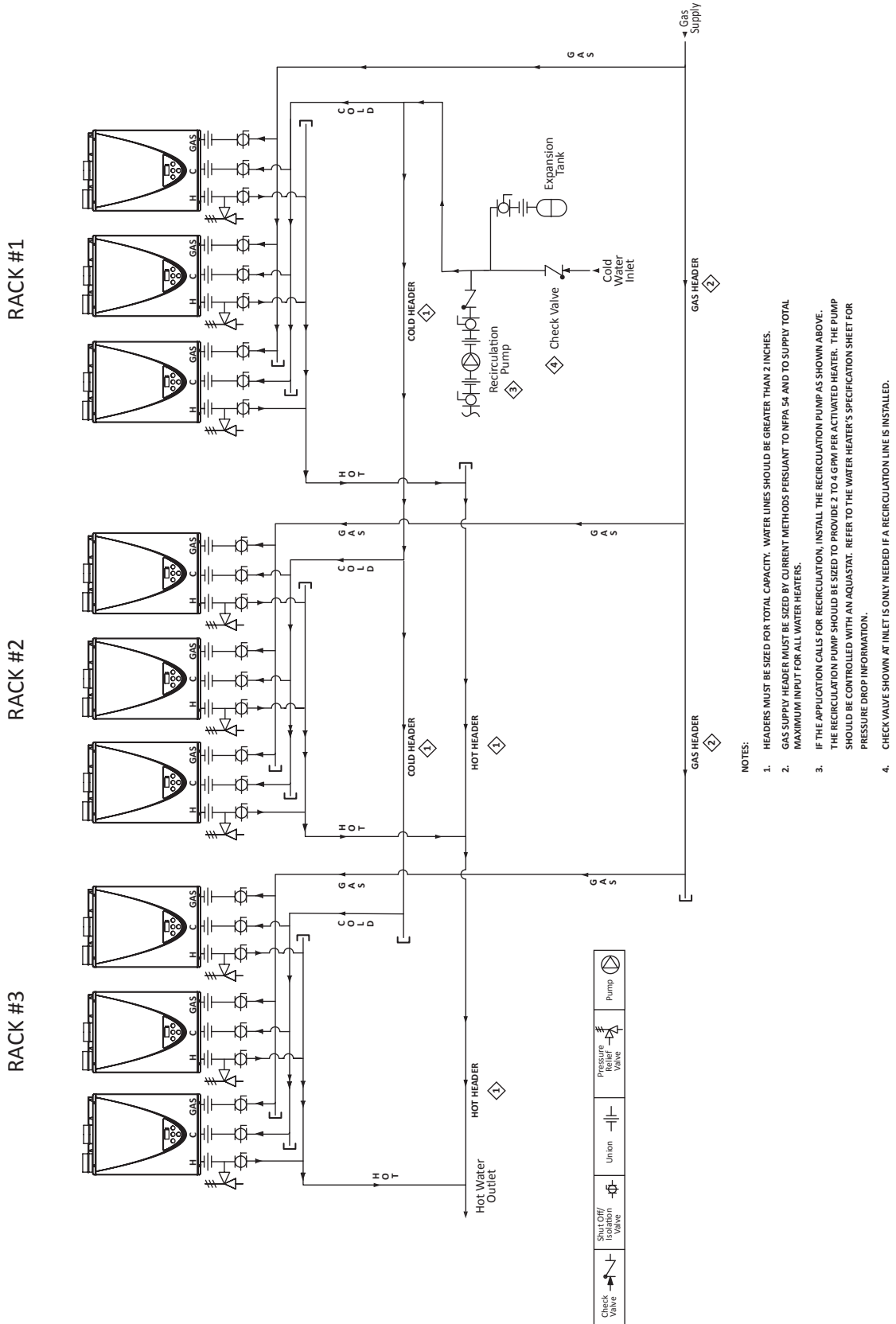

- NOTES:
1. HEADERS MUST BE SIZED FOR TOTAL CAPACITY. WATER LINES SHOULD BE GREATER THAN 2 INCHES.
  2. GAS SUPPLY HEADER MUST BE SIZED BY CURRENT METHODS PER SUANT TO NFPA 54 AND TO SUPPLY TOTAL MAXIMUM INPUT FOR ALL WATER HEATERS.
  3. IF THE APPLICATION CALLS FOR RECIRCULATION, INSTALL THE RECIRCULATION PUMP AS SHOWN ABOVE. THE RECIRCULATION PUMP SHOULD BE SIZED TO PROVIDE 2 TO 4 GPM PER ACTIVATED HEATER. THE PUMP SHOULD BE CONTROLLED WITH AN AQUASTAT. REFER TO THE WATER HEATER'S SPECIFICATION SHEET FOR PRESSURE DROP INFORMATION.
  4. CHECK VALVE SHOWN AT INLET IS ONLY NEEDED IF A RECIRCULATION LINE IS INSTALLED.

INSTALLATION MUST FOLLOW ALL APPLICABLE CODE REQUIREMENTS.

# MAINTENANCE

## ⚠ WARNING

- Read and follow all instructions, cautions, and warnings in the water heaters' Installation Manual and Owner's Guide. Failure to do so can lead to loss of life, personal injury, and/or property damage.
- Water heaters may be hard water scaled, which can cause leaks. For the descaling procedure, service technicians may reference the water heater's service handbook (DIR 2000534342).

## Replacing a Water Heater

1. Turn OFF the power supply, the gas supply, and the water supply.
2. Disconnect the power cable. If you have an outdoor model, verify that the electrical connections are not powered by checking them with a non-contact circuit tester.
  - Indoor Model: Simply unplug the power cord from the outlet.
  - Outdoor Model: Disconnect the power cable at the bottom of the water heater. See the water heater's *Installation Manual and Owner's Guide* for details.
3. Disconnect the gas, cold water, and hot water connections.
4. Remove the bolts as described below. The locations are shown by the arrows in Figure 7. If you have a wall mounted rack, see Figure 9.

**During this step, hold and support the water heater so that it does not fall.**

**Figure 7:** Location of nuts to be loosened / tightened. (Applies to each heater.)

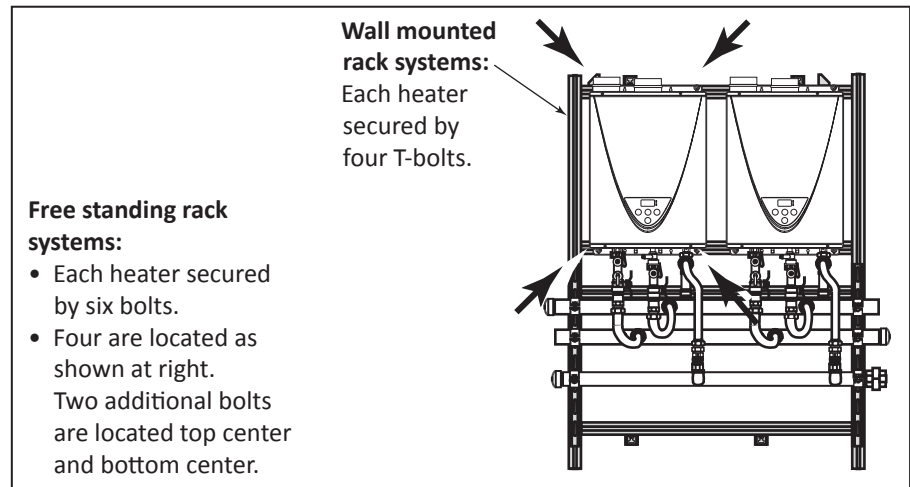

**Figure 8:** T-bolt indicator (wall mounted racks only).

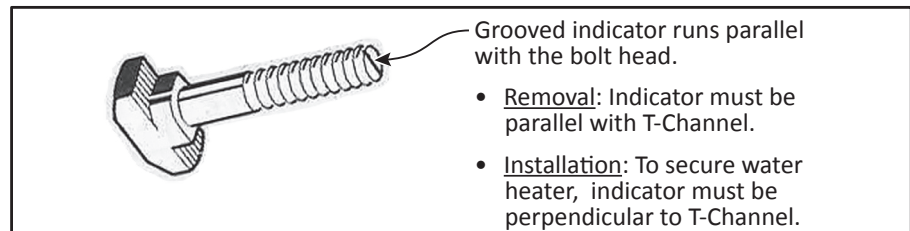

**Figure 9:** Securing the water heater to a wall mounted rack with T-bolts. Reverse the process to remove a water heater.

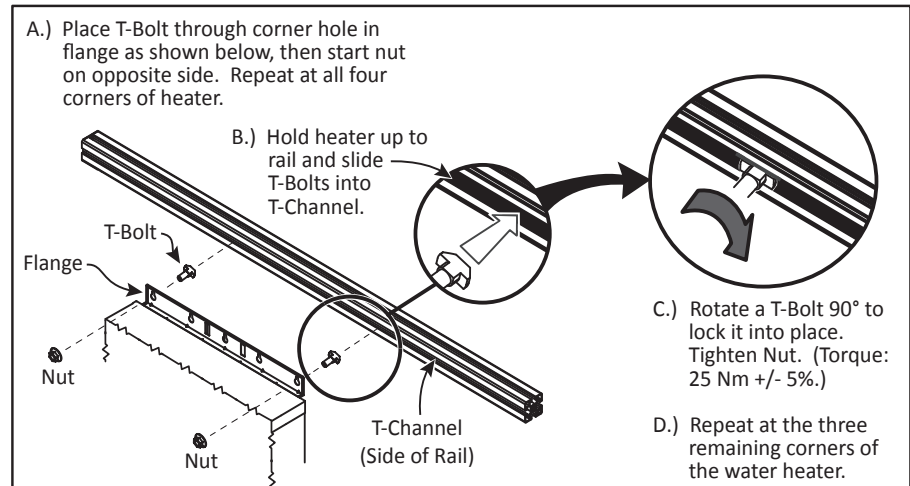

- **Free Standing Rack:** Remove the six bolts that secure the water heater.
- **Wall Mounted Rack:** Rotate each T-bolt 90-degrees to release the water heater from the rail. Look at the indicator

- at the end of each T-bolt to determine its orientation. The indicator should be parallel with the T-channel. See Figure 8.
- 5. Lift the water heater from the rack.
- 6. Secure the new water heater to the

---

rails. If the heater is being mounted on a wall mounted rack, refer to Figure 9.

7. Connect the water, gas, and electrical connections as outlined in the water heater's *Installation Manual and Owner's Guide*.
8. Return the water heater to service and verify proper operation.

## Troubleshooting and Service Procedures

For troubleshooting or service information, refer to the water heaters' *Installation Manual and Owner's Guide*. Service technicians may also reference the water heater's service handbook (DIR 2000534342).

# SPECIFICATIONS: WALL MOUNT (42" FRAME WIDTH)

## Two Units

Heater	CT-199, IN/OS*, NG/LP, 199,000 BTU/h
Number of Heaters	2
Total Input (BTU/h)	398,000
Max. Flow at 50°F ΔT (gpm)	15.2
Max. Flow at 60°F ΔT (gpm)	12.6
Max. Flow at 70°F ΔT (gpm)	10.8
Max. Flow at 80°F ΔT (gpm)	9.4
Max. Flow at 90°F ΔT (gpm)	8.4
Max. Flow at 100°F ΔT (gpm)	7.6
Rack/Frame Dimensions	Refer to the next page.
Frame Material	AW-6063 T66 Extruded Alloy with Clear Anodized Coating
Cold Water Header	2" dia. Copper Tube
Hot Water Header	2" dia. Copper Tube
Gas Line Header	1-1/2" Sch. 40, A53A, Blk
Water Connectors to Heaters	2' long, 3/4" dia. Stainless Steel Flex Line
Gas Connectors to Heaters	2' long, 3/4" dia. CSST

\* IN - Indoor Model; OS - Outdoor Model

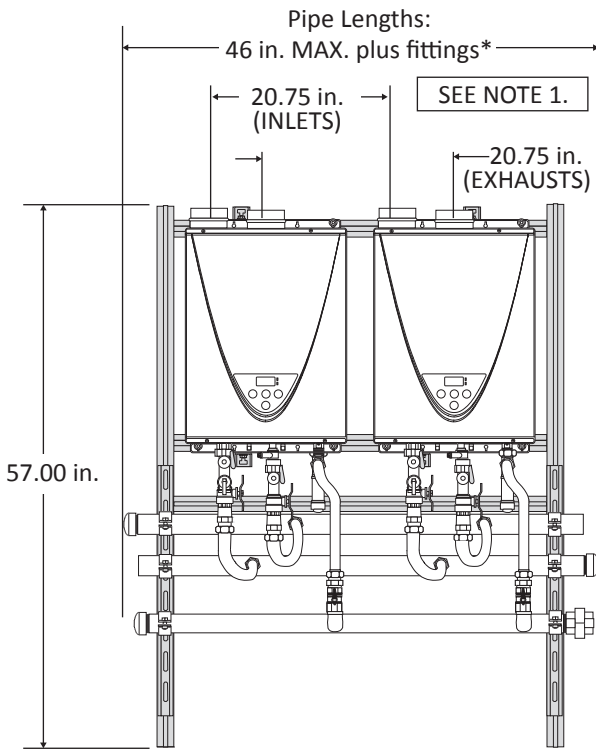

\* Fittings to be field supplied.

Front

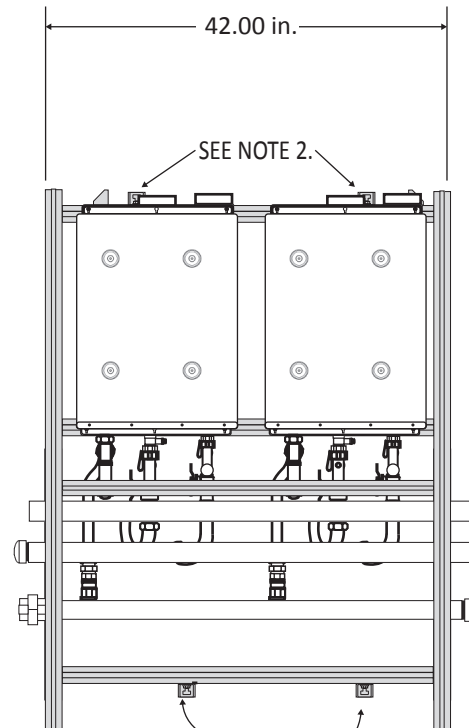

SEE NOTE 2.

Back

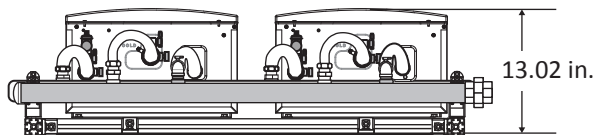

Bottom

**NOTICE:**  
Indoor models are shown in these graphics. However, some configurations include outdoor models. The dimensions are the same except as noted in the footnotes below.

**NOTES:**

1. TOP-MOUNTED AIR SUPPLY INLET/EXHAUST VENTS ARE USED WITH INDOOR MODELS ONLY.
2. MOUNTING BRACKETS ADJUST HORIZONTALLY ALONG CHANNEL SLOTS.
3. INDOOR AND OUTDOOR RACK SYSTEMS HAVE IDENTICAL DIMENSIONS. EXCEPTION: INDOOR MODELS HAVE TOP-MOUNTED INTAKES AND EXHAUSTS. OUTDOOR MODELS DO NOT.

# SPECIFICATIONS: WALL MOUNT (62.81" FRAME WIDTH)

## Basics (all configurations)

Rack/Frame Dimensions	Refer to the next page.
Frame Material	AW-6063 T66 Extruded Alloy with Clear Anodized Coating
Cold Water Header	2" dia. Copper Tube
Hot Water Header	2" dia. Copper Tube
Gas Line Header	1-1/2" Sch. 40, A53A, Blk
Water Connectors to Heaters	2' long, 3/4" dia. Stainless Steel Flex Line
Gas Connectors to Heaters	2' long, 3/4" dia. CSST

## Two Units

Heater	CT-199, IN/OS*, NG/LP, 199,000 BTU/h
Number of Heaters	2
Total Input (BTU/h)	398,000
Max. Flow at 50°F ΔT (gpm)	15.2
Max. Flow at 60°F ΔT (gpm)	12.6
Max. Flow at 70°F ΔT (gpm)	10.8
Max. Flow at 80°F ΔT (gpm)	9.4
Max. Flow at 90°F ΔT (gpm)	8.4
Max. Flow at 100°F ΔT (gpm)	7.6

\* IN - Indoor Model; OS - Outdoor Model

## Three Units

Heater	CT-199, IN/OS*, NG/LP, 199,000 BTU/h
Number of Heaters	3
Total Input (BTU/h)	597,000
Max. Flow at 50°F ΔT (gpm)	22.8
Max. Flow at 60°F ΔT (gpm)	18.9
Max. Flow at 70°F ΔT (gpm)	16.2
Max. Flow at 80°F ΔT (gpm)	14.1
Max. Flow at 90°F ΔT (gpm)	12.6
Max. Flow at 100°F ΔT (gpm)	11.4

\* IN - Indoor Model; OS - Outdoor Model

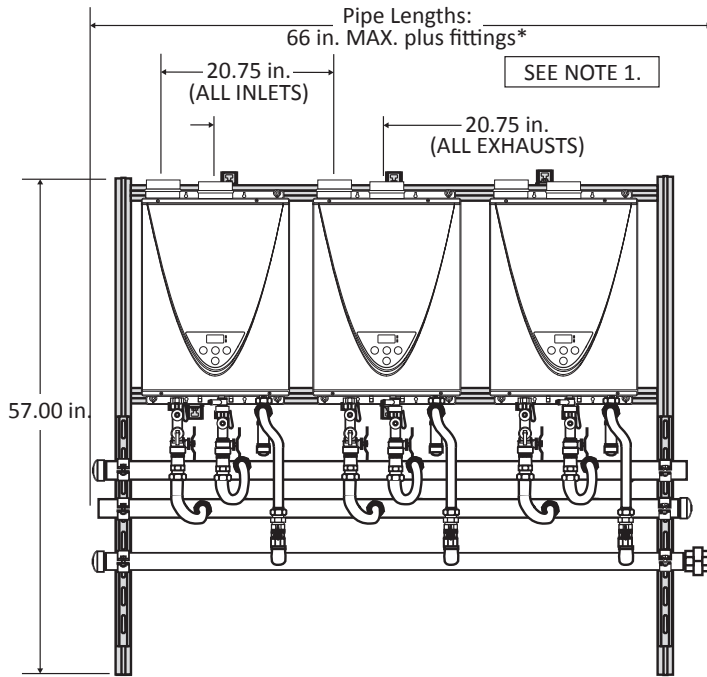

Front

\* Fittings to be field supplied.

**NOTICE:**

- Your configuration may include two or three water heaters.
- Indoor models are shown in these graphics. However, some configurations include outdoor models. The dimensions are the same except as noted in the footnotes below.

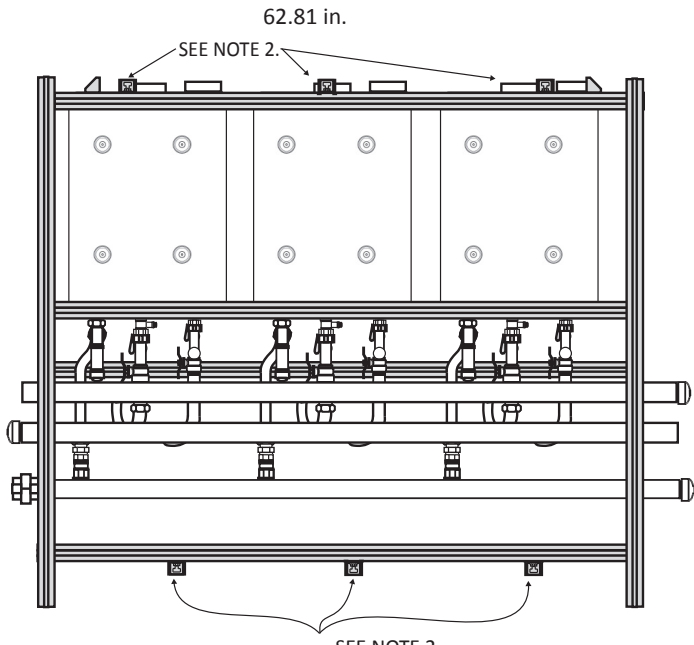

Back

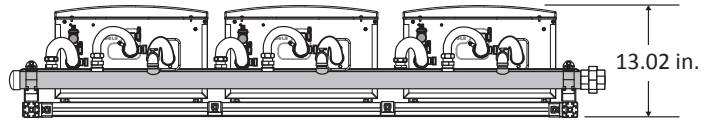

Bottom

**NOTES:**

1. TOP-MOUNTED AIR SUPPLY INLET/EXHAUST VENTS ARE USED WITH INDOOR MODELS ONLY.
2. MOUNTING BRACKETS ADJUST HORIZONTALLY ALONG CHANNEL SLOTS.
3. INDOOR AND OUTDOOR RACK SYSTEMS HAVE IDENTICAL DIMENSIONS. EXCEPTION: INDOOR MODELS HAVE TOP-MOUNTED INTAKES AND EXHAUSTS. OUTDOOR MODELS DO NOT.

# SPECIFICATIONS: FREE STANDING (41.54" FRAME WIDTH)

## Basics (all configurations)

Rack/Frame Dimensions	Refer to the next page.
Frame Material	Marine grade aluminum 6061-T6 or 5052-H32 (0.08 in. thickness)
Cold Water Header	2" dia. Copper Tube
Hot Water Header	2" dia. Copper Tube
Gas Line Header	1-1/2" Sch. 40, A53A, Blk
Water Connectors to Heaters	2' long, 3/4" dia. Stainless Steel Flex Line
Gas Connectors to Heaters	2' long, 3/4" dia. CSST

\* IN - Indoor Model; OS - Outdoor Model

## Two Units

Heater	CT-199, IN/OS*, NG/LP, 199,000 BTU/h
Number of Heaters	2
Total Input (BTU/h)	398,000
Max. Flow at 50°F ΔT (gpm)	15.2
Max. Flow at 60°F ΔT (gpm)	12.6
Max. Flow at 70°F ΔT (gpm)	10.8
Max. Flow at 80°F ΔT (gpm)	9.4
Max. Flow at 90°F ΔT (gpm)	8.4
Max. Flow at 100°F ΔT (gpm)	7.6

\* IN - Indoor Model; OS - Outdoor Model

## Three Units

Heater	CT-199, IN/OS*, NG/LP, 199,000 BTU/h
Number of Heaters	3
Total Input (BTU/h)	597,000
Max. Flow at 50°F ΔT (gpm)	22.8
Max. Flow at 60°F ΔT (gpm)	18.9
Max. Flow at 70°F ΔT (gpm)	16.2
Max. Flow at 80°F ΔT (gpm)	14.1
Max. Flow at 90°F ΔT (gpm)	12.6
Max. Flow at 100°F ΔT (gpm)	11.4

\* IN - Indoor Model; OS - Outdoor Model

## Four Units

Heater	CT-199, IN/OS*, NG/LP, 199,000 BTU/h
Number of Heaters	4
Total Input (BTU/h)	796,000
Max. Flow at 50°F ΔT (gpm)	30.4
Max. Flow at 60°F ΔT (gpm)	25.2
Max. Flow at 70°F ΔT (gpm)	21.6
Max. Flow at 80°F ΔT (gpm)	18.8
Max. Flow at 90°F ΔT (gpm)	16.8
Max. Flow at 100°F ΔT (gpm)	15.2

\* IN - Indoor Model; OS - Outdoor Model

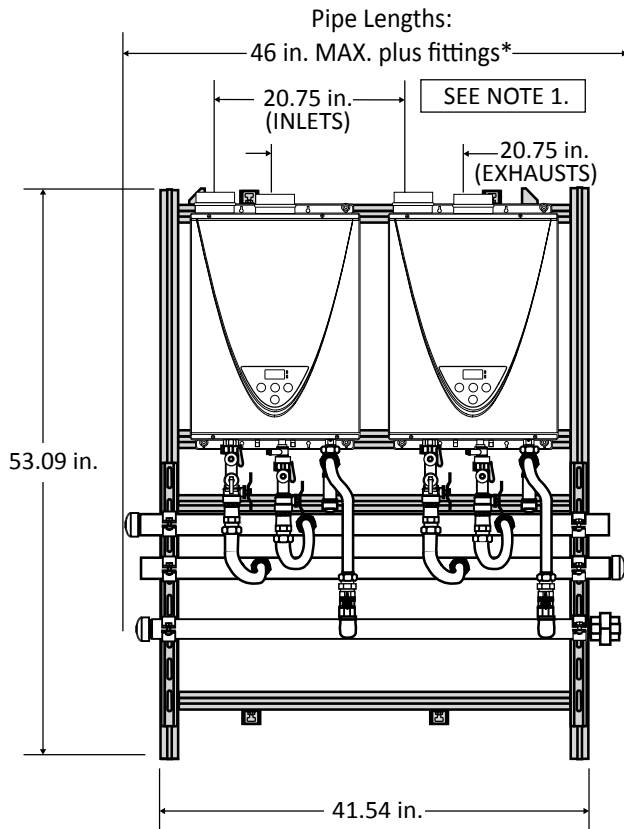

Front

**NOTICE:**

- Your configuration may include two, three, or four water heaters.
- Indoor models are shown in these graphics. However, some configurations include outdoor models. The dimensions are the same except as noted in the footnotes below.

\*Fittings to be field supplied.

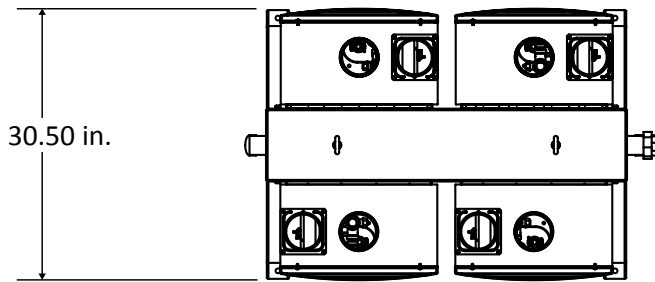

Top

**NOTES:**

1. TOP-MOUNTED AIR SUPPLY INLET/EXHAUST VENT ARE USED WITH INDOOR MODELS ONLY.
2. INDOOR AND OUTDOOR RACK SYSTEMS HAVE IDENTICAL DIMENSIONS. EXCEPTION: INDOOR MODELS HAVE TOP-MOUNTED INTAKES AND EXHAUSTS. OUTDOOR MODELS DO NOT.

# SPECIFICATIONS: FREE STANDING (62.29" FRAME WIDTH)

## Basics (all configurations)

Rack/Frame Dimensions	Refer to the next page.
Frame Material	Marine grade aluminum 6061-T6 or 5052-H32 (0.08 in. thickness)
Cold Water Header	2" dia. Copper Tube
Hot Water Header	2" dia. Copper Tube
Gas Line Header	1-1/2" Sch. 40, A53A, Blk
Water Connectors to Heaters	2' long, 3/4" dia. Stainless Steel Flex Line
Gas Connectors to Heaters	2' long, 3/4" dia. CSST

\* IN - Indoor Model; OS - Outdoor Model

## Three Units

Heater	CT-199, IN/OS*, NG/LP, 199,000 BTU/h
Number of Heaters	3
Total Input (BTU/h)	597,000
Max. Flow at 50°F ΔT (gpm)	22.8
Max. Flow at 60°F ΔT (gpm)	18.9
Max. Flow at 70°F ΔT (gpm)	16.2
Max. Flow at 80°F ΔT (gpm)	14.1
Max. Flow at 90°F ΔT (gpm)	12.6
Max. Flow at 100°F ΔT (gpm)	11.4

\* IN - Indoor Model; OS - Outdoor Model

## Four Units

Heater	CT-199, IN/OS*, NG/LP, 199,000 BTU/h
Number of Heaters	4
Total Input (BTU/h)	796,000
Max. Flow at 50°F ΔT (gpm)	30.4
Max. Flow at 60°F ΔT (gpm)	25.2
Max. Flow at 70°F ΔT (gpm)	21.6
Max. Flow at 80°F ΔT (gpm)	18.8
Max. Flow at 90°F ΔT (gpm)	16.8
Max. Flow at 100°F ΔT (gpm)	15.2

\* IN - Indoor Model; OS - Outdoor Model

## Five Units

Heater	CT-199, IN/OS*, NG/LP, 199,000 BTU/h
Number of Heaters	5
Total Input (BTU/h)	995,000
Max. Flow at 50°F ΔT (gpm)	38
Max. Flow at 60°F ΔT (gpm)	31.5
Max. Flow at 70°F ΔT (gpm)	27
Max. Flow at 80°F ΔT (gpm)	23.5
Max. Flow at 90°F ΔT (gpm)	21
Max. Flow at 100°F ΔT (gpm)	19

\* IN - Indoor Model; OS - Outdoor Model

# Six Units

Heater	CT-199, IN/OS*, NG/LP, 199,000 BTU/h
Number of Heaters	6
Total Input (BTU/h)	1,194,000
Max. Flow at 50°F ΔT (gpm)	45.6
Max. Flow at 60°F ΔT (gpm)	37.8
Max. Flow at 70°F ΔT (gpm)	32.4
Max. Flow at 80°F ΔT (gpm)	28.2
Max. Flow at 90°F ΔT (gpm)	25.2
Max. Flow at 100°F ΔT (gpm)	22.8

\* IN - Indoor Model; OS - Outdoor Model

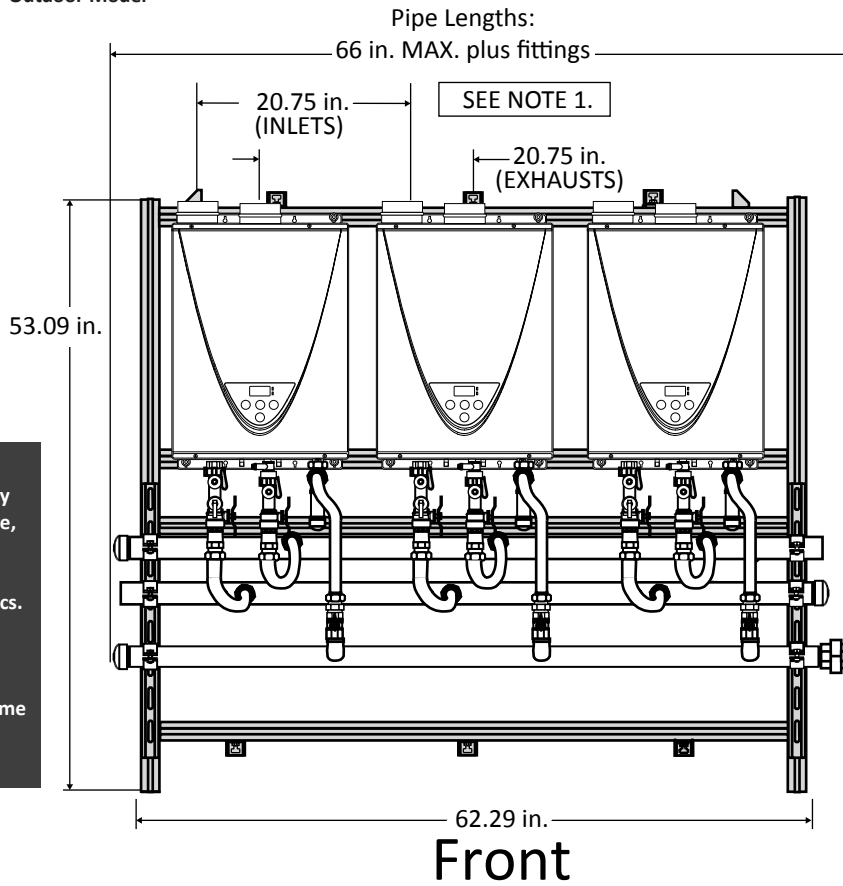

## NOTICE:

- Your configuration may include three, four, five, or six water heaters.
- Indoor models are shown in these graphics. However, some configurations include outdoor models. The dimensions are the same except as noted in the footnotes below.

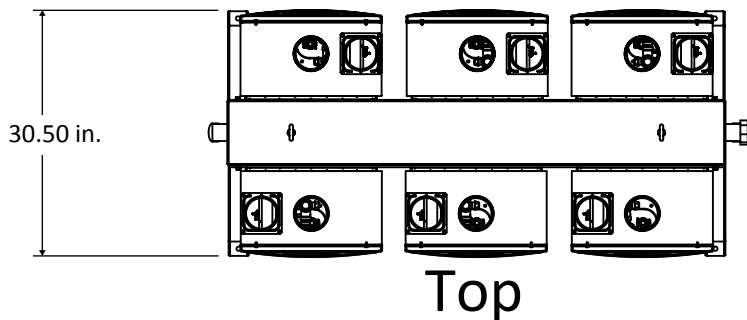

## NOTES:

1. TOP-MOUNTED AIR SUPPLY INLET/EXHAUST VENT ARE USED WITH INDOOR MODELS ONLY.
2. INDOOR AND OUTDOOR RACK SYSTEMS HAVE IDENTICAL DIMENSIONS. EXCEPTION: INDOOR MODELS HAVE TOP-MOUNTED INTAKES AND EXHAUSTS. OUTDOOR MODELS DO NOT.

# REPLACEMENT PARTS

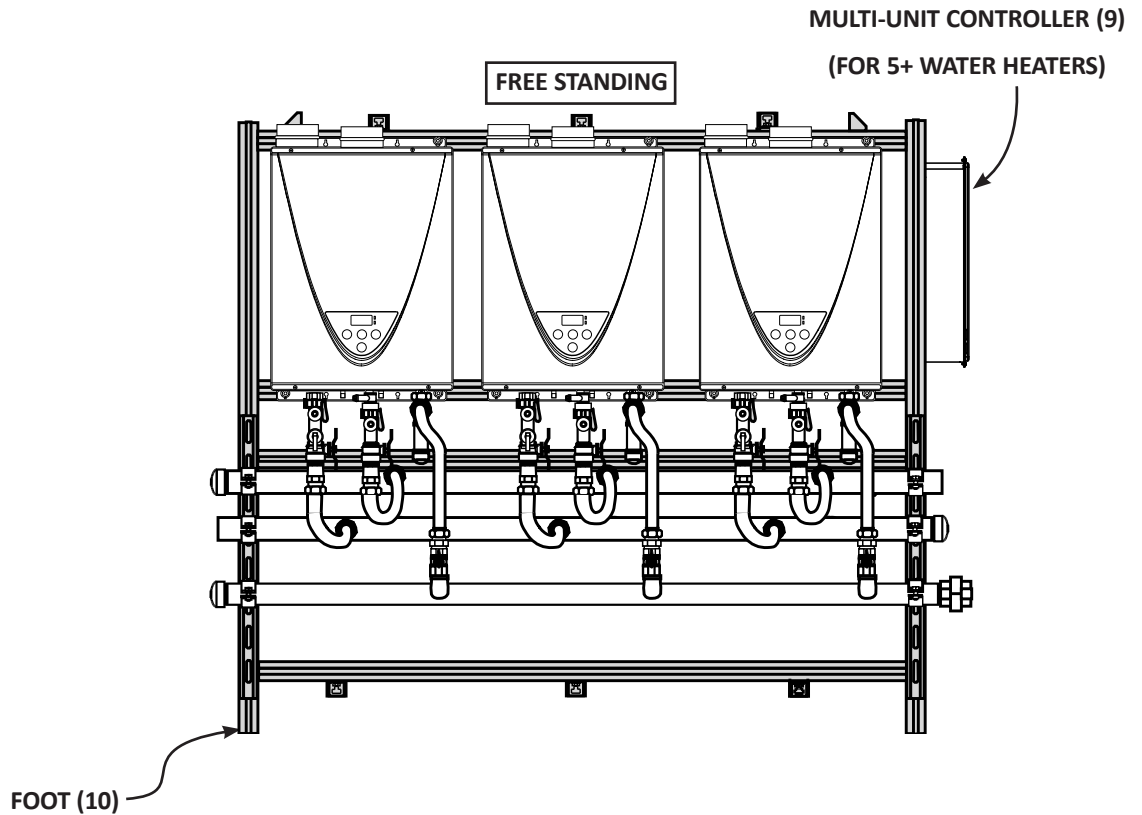
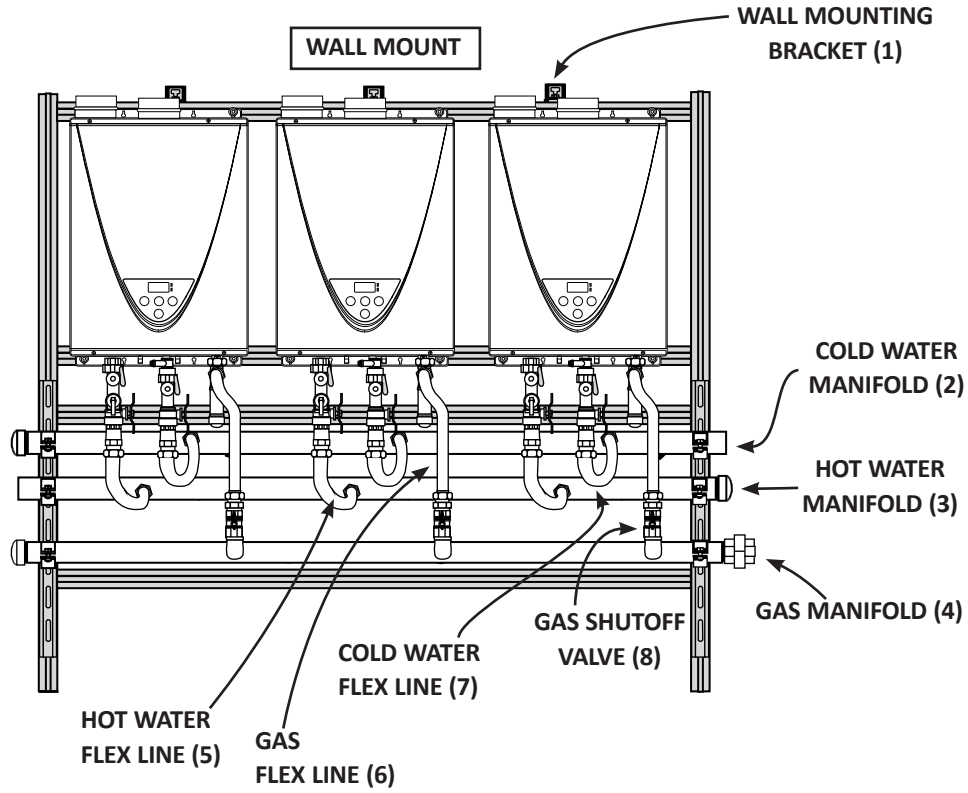

REPLACEMENT PARTS

ITEM	DESCRIPTION
1	Wall mounting bracket (wall mounted models only)
2	Manifold, cold water
3	Manifold, hot water
4	Manifold, gas
5	Flex line, hot water
6	Flex line, gas
7	Flex line, cold water
8	Gas shutoff valve
9	Multi-unit controller (for 5+ water heaters)
10	Foot (free standing models)
11	Wall mount (wall mounted models)

**WALL MOUNT / UPRIGHT FRAME (11)**

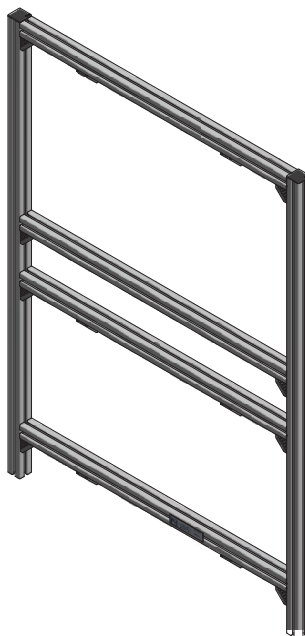

# NOTES

---

NOTES

# NOTES

---

NOTES

Copyright © 2020. All rights reserved.

Questions? Call toll free: 877-737-2840.