

# Installation Manual

## INTER-APPLIANCE COMMUNICATIONS

### Communication Node for EMS/BMS Control

**Models**  
Ethernet (ETH-1000) for BACnet IP  
and Modbus TCP

**Serials**  
Mirius (Serial RS-485) for BACnet MS/TP  
and Modbus RTU

Energy Management System  
Building Management System  
Installation

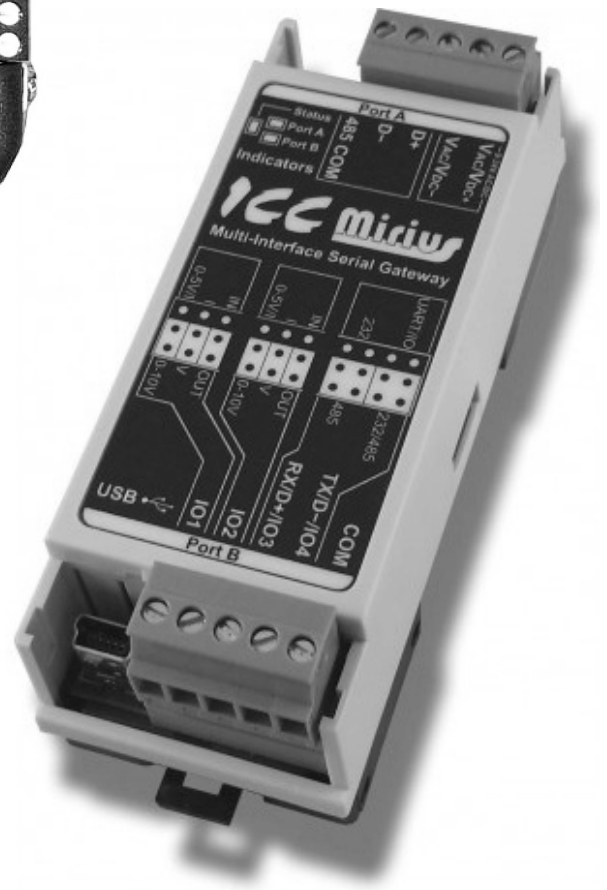

# CONTENTS

<p>INTRODUCTION ..... 3</p> <p style="padding-left: 20px;">Warnings ..... 3</p> <p style="padding-left: 20px;">Parts ..... 3</p> <p style="padding-left: 20px;">Tools Required ..... 3</p> <p style="padding-left: 20px;">General Guidelines ..... 3</p> <p>FEATURES AND COMPONENTS ..... 5</p> <p>DEVICE CONFIGURATIONS ..... 6</p> <p style="padding-left: 20px;">ETH-1000 Wiring ..... 6</p> <p style="padding-left: 20px;">Mirus Wiring ..... 6</p> <p>INSTALLATION CONSIDERATIONS ..... 8</p> <p style="padding-left: 20px;">Commercial Electric Water Heater Installation ..... 8</p> <p style="padding-left: 20px;">Commercial Electric Water Heater Installation ..... 8</p> <p style="padding-left: 40px;"><i>Connecting the Communications Cable to the Module</i> ..... 8</p> <p style="padding-left: 20px;">Commercial Electric Water heater Installation ..... 8</p> <p>BACnet / Electric Water Heaters ..... 10</p> <p style="padding-left: 20px;">Product Description ..... 10</p> <p style="padding-left: 20px;">Protocol Implementation Conformance Statement (PICS) ..... 10</p> <p style="padding-left: 40px;"><i>BACnet Standardized Device Profile (Annex L)</i> ..... 10</p> <p style="padding-left: 40px;"><i>BACnet Interoperability</i> ..... 10</p>	<p style="padding-left: 20px;"><i>Segmentation Capability</i> ..... 11</p> <p style="padding-left: 20px;"><i>Data Link Layer Options</i> ..... 11</p> <p style="padding-left: 20px;"><i>Device Address Binding</i> ..... 11</p> <p style="padding-left: 20px;"><i>Networking Options</i> ..... 11</p> <p style="padding-left: 20px;"><i>Character Sets</i> ..... 11</p> <p style="padding-left: 20px;"><i>Data Types</i> ..... 12</p> <p style="padding-left: 20px;"><i>Object Types and Property Support</i> ..... 12</p> <p>Device Object Listings ..... 13</p> <p style="padding-left: 20px;"><i>Device Objects Initial Values</i> ..... 13</p> <p style="padding-left: 20px;"><i>Device Objects Minimum/Maximum Values</i> ..... 13</p> <p style="padding-left: 20px;"><i>Central Control Board Major State Definitions</i> ..... 17</p> <p style="padding-left: 20px;"><i>Energy Management System (EMS) Control</i> ..... 17</p> <p style="padding-left: 20px;"><i>Fault Codes and Warnings</i> ..... 17</p> <p>Modbus / Electric Water Heaters ..... 19</p> <p style="padding-left: 20px;">Product Description ..... 19</p> <p style="padding-left: 20px;">Electric Water Heater Register Listings ..... 19</p> <p style="padding-left: 40px;"><i>Modbus Electric Water Heaters Register Properties</i> ..... 19</p> <p style="padding-left: 40px;"><i>Central Control Board Major State Definitions</i> ..... 22</p> <p style="padding-left: 40px;"><i>Energy Management System (EMS) Control</i> ..... 22</p> <p style="padding-left: 40px;"><i>Fault Codes and Warnings</i> ..... 22</p> <p>ICC PROGRAM INFORMATION ..... 23</p>
---	--

# INTRODUCTION

New building construction and energy saving techniques have driven the need for improved communications between appliances and building environmental systems. There are several different protocols that have developed for accomplishing this task including BACnet and Modbus. Since appliances come with a variety of controls, interfacing with the various protocols presents different challenges.

Industrial Control Communications (ICC) has developed the devices to act as a communication gateway allowing appliances to communicate to the different building management protocols. The ICC module translates the appliance codes and commands into the appropriate protocol language giving the end user the ability to monitor and control the appliance. The end user will be able to adjust and monitor the equipment and obtain better levels of efficiency and cost savings.

The ICC module in this kit has been designed to seamlessly integrate with the water heater controls. Once the unit is connected to the control and to the energy management system, the user will be able to operate the unit with the Building Management system interface.

## WARNINGS

When installing the unit, ensure that all power is off before opening any water heater enclosure. Failure to do so could result in electrical shock and/or possible damage to the unit.

Do not install in areas of high temperature, in excess of 167° F. Install in areas not subject to water or excess moisture.

## PARTS

Table 1. Parts Required		
Item	Ethernet	Serial (RS-485)
ICC Module	X	X
Communication Cable	X	X
Power Adapter	X	X
Jumpers	4	4
Splitter	X	X
USB Key	X	X

## TOOLS REQUIRED

Wire Cutters

- 24 AWG Wire Stripper
- 2.5 mm Flat Blade Screw Driver

## GENERAL GUIDELINES

The module should be installed as close as practical to the water heater control.

The ICC module uses a 120 Volt power adapter to supply 9 volts DC for the unit. One 120 VAC outlet is required for each module installed. The power adapter comes with a six foot length of wire. If additional wire is needed, extra wire may be added, in accordance with local ordinances for installation of low voltage wire.

The ICC Gateway kit contains a USB key with the ICC Configuration Studio program, all configuration files, parameter lists and instructions

required to install and configure to your water heater/boiler and BMS system.

Before plugging in the ICC Gateway, install the ICC Configuration Studio from the USB key and run the program. Once running, select File, Open Project and browse to the USB key and select the configuration file whose name matches the gateway,

Because some USB hubs may not supply sufficient current to run the Gateway, insure that the ICC Gateway is connected to the power adapter. Then connect the ICC Gateway using the USB cable provided. Run the ICC Gateway Studio application from the start menu.

Each configuration has default address and BACnet instance settings that can be changed. For Mirius gateways, the default Modbus address is 1 and the default BACnet address is 81. For gas models the default BACnet Instance Number is 520081 and for electric models the default instance number is 530081. For Ethernet Gateways, the default setting is to acquire an IP address automatically from the router (DHCP). If a static IP address is desired this can also be set. To change these addresses and communication settings, use the ICC Configuration Studio application program. The latest version of this application program can be downloaded from:

[www.iccdesigns.com/icc-configuration-studio.html](http://www.iccdesigns.com/icc-configuration-studio.html)

Before making any changes, it is recommended to save the installed configuration project using the disk icon or **File -> Save Project As**, then give it a name and select the folder, finally press **Save**.

To change the Instance number and the Device Name, scroll down and select the Device Object and replace the text in the boxes in the upper right corner.

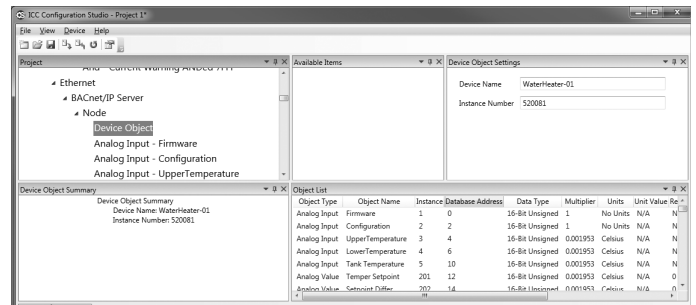

**Figure 1. Changing Instance Number and Device Name**

For ETH-1000 (Ethernet interface) the IP settings, including DHCP/Static, the IP address and authentication can be changed by selecting Ethernet from the upper left hand window and changing the text and drop down list selection similar to changing the Instance number above.

For Mirius (RS-485 A interface for BACnet MS/TP or Modbus RTU), the baud rate and other serial communication parameters can be changed by scrolling down to and selecting **RS-485 A -> ModBus RTU Slave**.

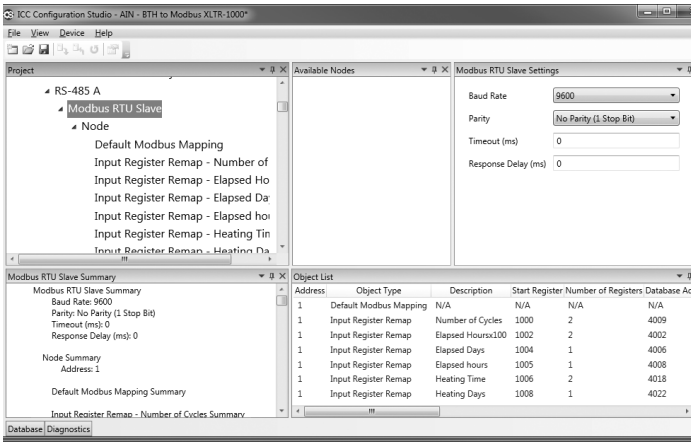

**Figure 2. Changing ModBus Parameters**

The ModBus address can be changed by selecting Node under the RS-485 A -> ModBus RTU item.

Likewise for BACnet, the baud rate and other serial communication parameters can be changed by scrolling down to and selecting RS-485 -> BACnet MS/TP Server. The BACnet MAC Address can be changed by selecting Node under the RS-485 A->BACnet MS/TP Server.

**Warning:** Do not change any other values other than these or the gateway configuration may not function properly. In this case, the file saved above can be reloaded to start over.

When changes are complete press the **Download Configuration** icon:

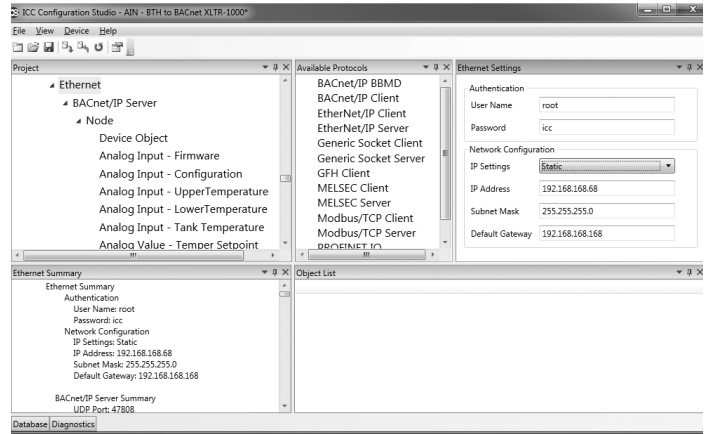

**Figure 3. Changing BACnet Parameters**

# FEATURES AND COMPONENTS



Figure 4. ICC ETH-1000 (Ethernet) Version



Figure 5. ICC Merius Serial RS-485 Version

- Works with Cyclone (BTH, BTHL, BTX-100, BTXL-100), McBee DVE, DSE/DVE/DHE.
- Works with Ultra Force, SUF, SUFL, SHE, SEV/SEH, SSE and CSB-1FE.
- Use the ICC Control to enable/disable the water heater.
- Change Temperature Set points and differentials.
- Two models with four different configurations to connect to BACnet and Modbus.
- Ethernet and Serial RS-485 versions available.
- Two-wire RS-485 versions available.
- Power can be supplied via the USB cable, as a 7-24 VDC input on the main terminal block, or via IEEE 802.3af Power over Ethernet (PoE on ETH-1000 only).
- Configure protocols, network characteristics, and client/server object definitions.
- Graphically interact with the internal database in real-time via the USB connection.
- Automatically discover and configure IP settings Ethernet gateways connected to the current subnet.
- Update firmware.

Table 2. ICC Versions		
Kit	Connection	Part Number
Mirius	Serial - RS485 (RTU/MS/TP)	<a href="#">100316044</a>
ETH-1000	Ethernet - RJ-45	100316045

# DEVICE CONFIGURATIONS

## ETH-1000 WIRING

**Figure 6** shows the standard configuration of the Ethernet modules. The module has connections for 9 VDC power, three wire connections for the communication breakout cable, and a port for the connection of the EMS system through Ethernet RJ-45 cable communications.

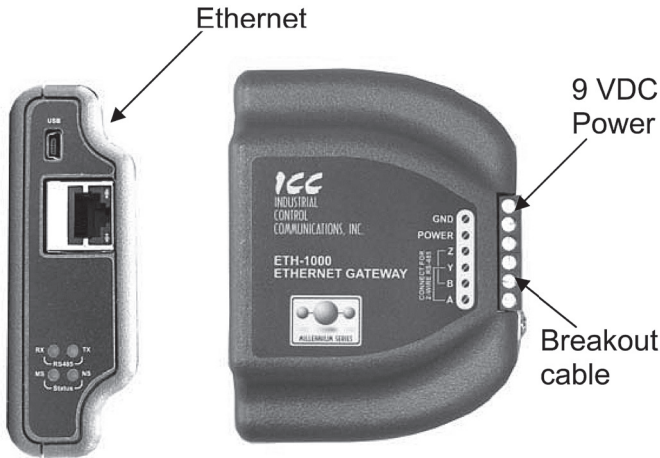

**Figure 6. Standard Configuration for Ethernet Modules**

Connecting of the power adapter and the boiler or water heater communication cable to the module is accomplished on the same end of the unit. **Figure 7** is a close up of the connection terminal and **Figure 8** shows the appropriate connection to the strip using the power adapter and communication cable.

The provided communication cable has two RJ-45 plugs. Remove one with a wire cutter, then locate and strip the 3 wires described below and strip 1/2 inch of insulation before connecting.

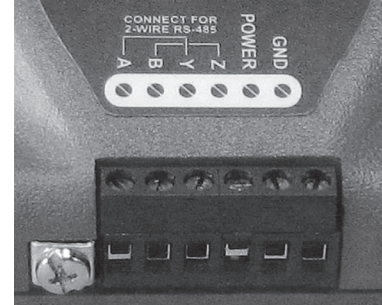

**Figure 7. Connecting the Power Adapter**

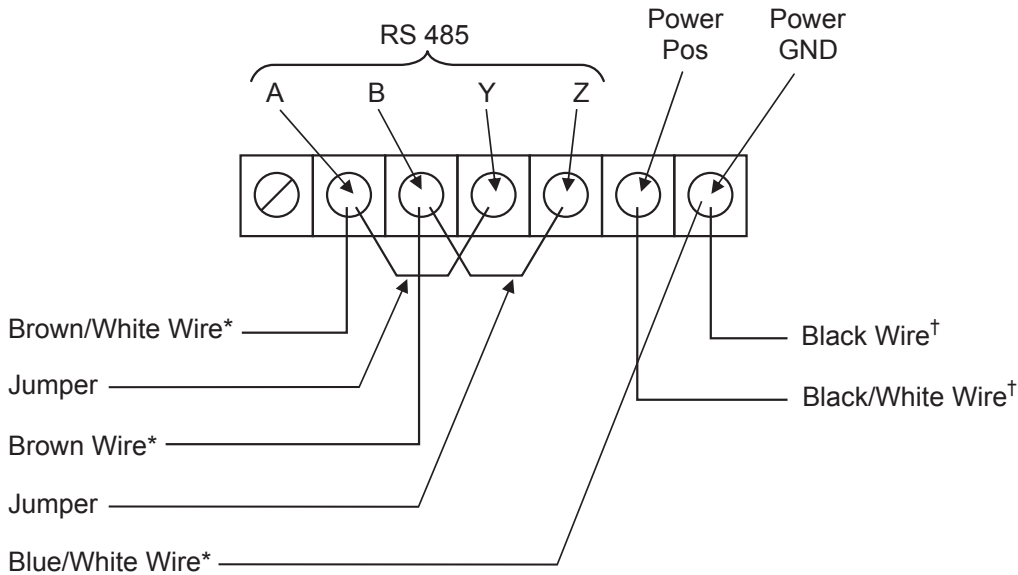

\*From Communication Cable

†From 9 VDC Power Adapter Cable

**Figure 8. Connections from the Communications and Power Adapter Cables**

The connections in **Figure 8** are the same regardless of the appliance or the communication protocol.

At the opposite end of the module is the connection location for the EMS LAN connection. The EMS uses an Ethernet connection with an RJ-45 connector. Plug the cable into the RJ-45 receptacle.

For more information on connecting the ICC Gateway to your Building Management System, please refer to the User Manual provided on the enclosed USB key in the “Documents” folder. The two applicable documents will be found in the Manuals.

## MIRIUS WIRING

**Figure 9** shows the standard configuration of the module. Port A of the module has connections for 9 VDC power and serial communications for EMS/BMS (BACnet or Modbus). Port B has connections for the communication (breakout) cable for serial communications to the water heater/boiler.

**Figure 10** is a close up of the connection terminal and **Figure 11** shows the appropriate connection to the strip using the power adapter and EMS/BMS communication cable.

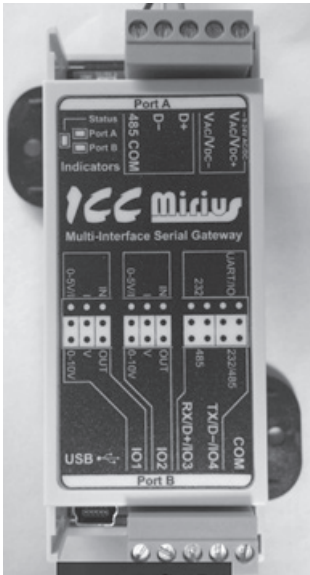

Figure 9. Mirius Unit with Communications Terminal



Figure 10. Mirius Port A Terminal

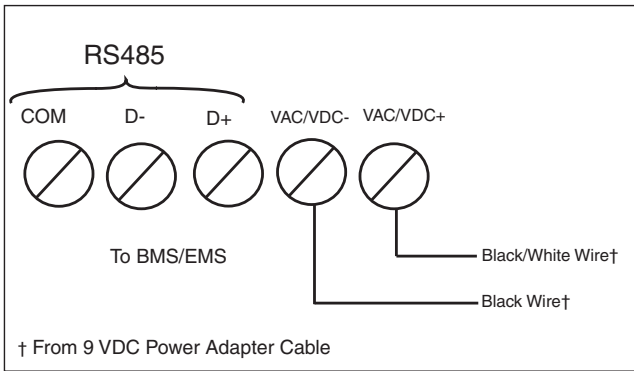

Figure 11. Port A Connection Diagram

The connections in **Figure 11** are the same regardless of the appliance or the communication protocol.

Port A of the module is the connection location for the EMS/BMS connection. See **Figure 10**. For connections to the terminal use the labeling on the module as a guide.

When connecting the RS-485A connections (BACnet or Modbus) please note the following:

- Only 2-wire systems are supported
- Connect the RX/TX+ (plus) wire from your Building Management System to terminal D+. Connect the RX/TX- (minus) wire from your Building Management System to terminal D-.

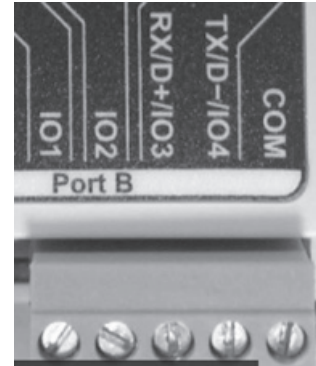

Figure 12. Close-Up View of Connection Terminal

Port B of the module is the connection for the water heater/boiler connection. See **Figure 12** for the connection to the terminal. Use the labeling on the module as a guide.

The provided communication cable has two RJ-45 plugs. Remove one with a wire cutter, then locate and strip the 3 wires described below and strip 1/2 inch of insulation before connecting.

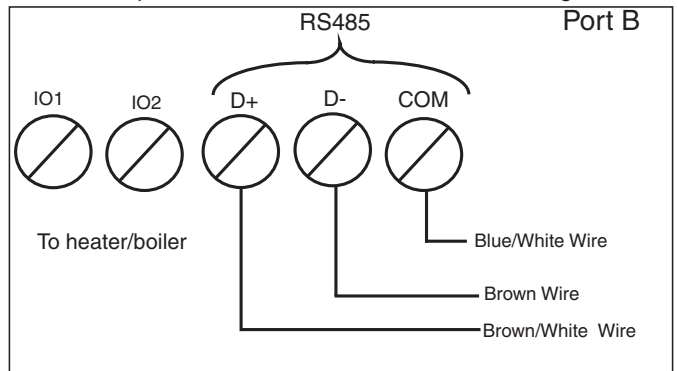

Figure 13. Port B Connection Diagram

# INSTALLATION CONSIDERATIONS

## COMMERCIAL ELECTRIC WATER HEATER INSTALLATION

This section pertains to compact ASME, standard high power, & custom (with immersion thermostat) high-power water heaters .

Follow the directions under general guidelines for connecting the module to the Energy Management System and power. This section will guide the installer on how to mount and connect the module to the water heater. The control box and mounting location on the water heater is on the top of the unit behind the display module.

Connection of the RJ-45 end of the communication cable to the heater is required to plug into J13 of the control board inside the "black controls box" (for newer models) requiring removal of two screws holding the lid on. After plugging in the communications cable, route the cable to the bottom side with the other cables and put the lid back on with the two screws.

## COMMERCIAL ELECTRIC WATER HEATER INSTALLATION

Follow directions in *Device Configurations* (page 6) for connecting the module to the Energy Management System and power. This section will guide the installer on how to mount and connect the module to the water heater.

The module should be located where it will not interfere with the door or in a location that is acceptable to the customer. Care should be exercised to avoid drilling the self-tapping screws into electrical or sensitive components. Electrical power should be disconnected before proceeding with ICC installation.

Using a flat blade screwdriver, loosen the screws holding the door of the unit. See *Figure 14*.

Swing the door to the open position and locate the control board. See *Figure 15*.

### Connecting the Communications Cable to the Module

Connect the three wires from the end of the communication cable to the module in accordance with Figure 24. Once the unit is installed and connected, the building management system can be connected to the appropriate connection point on the module.



Figure 14. Loosening the Screws to the Door of the Unit

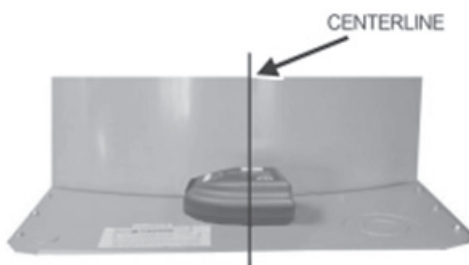

Figure 15. ICC Location Relative to Centerline

Remove the hole plug from the 0.875" knockout on the left corner of the top panel. See *Figure 16*.

Plug the communications cable into D9 and run the three wire connection up through the knockout and connect the three wires to the module as shown on page 4. Once the unit is installed and connected, the building management system can be connected to the appropriate connection point on the module.



Figure 16. Location of Communications Wiring Knockout

## COMMERCIAL ELECTRIC WATER HEATER INSTALLATION

Follow directions in *Device Configurations* (page 6) for connecting the module to the Energy Management System and power. This section will guide the installer on how to mount and connect the module to the water heater.

The module should be located where it will not interfere with the door or in a location that is acceptable to the customer. Care should be exercised to avoid drilling the self tapping screws into electrical or sensitive components. Electrical power should be disconnected before proceeding with ICC installation.

Using a flat blade screwdriver, loosen the screws holding the door of the unit. See *Figure 17*.

Swing the door to the open position and locate the back of the display module. See *Figure 18*.



Figure 17. Loosening the Screws to the Door of the Unit

Unplug the display communication cable from the display. Plug the RJ45 plug from the split communication cable into the back of the display. See *Figure 19*.

Plug the display cable into the split cable receptacle as shown in *Figure 20*. Plug the supplied wiring harness with the gateway controller into the remaining open RJ45 port on the Split Communication cable (Not shown).

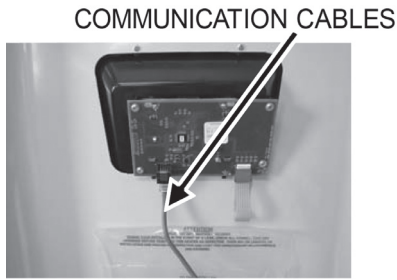

**Figure 18. Locating the Communications Cable on Back of the Display**

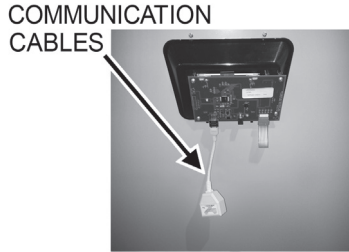

**Figure 19. Reconnecting RJ45 Plug from Split Communication Cable**

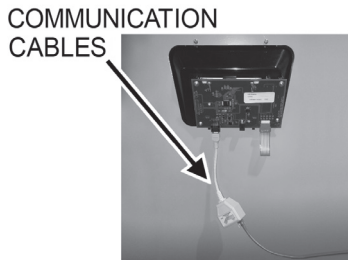

**Figure 20. Connecting the Display Cable to Split Cable Receptacle**  
 Locate the module on the top of the door cabinet approximately 1 inch from the water heater jacket and on the centerline of the unit (See *Figure 21* and *Figure 22*).



**Figure 21. Locating the Module**

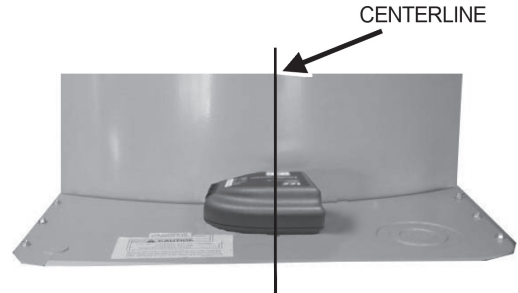

**Figure 22. Module Location Relative to Centerline**

Remove the hole plug from the 0.875" knockout on the left corner of the top panel. See *Figure 23*.

Run the three wire connection from the split cable up and through the knockout and connect the three wires to the module as shown on page 4. Once the unit is installed and connected, the building management system can be connected to the appropriate connection point on the module.



**Figure 23. Knockout on Left Corner of Top Panel**

**BACNET / ELECTRIC WATER HEATERS**

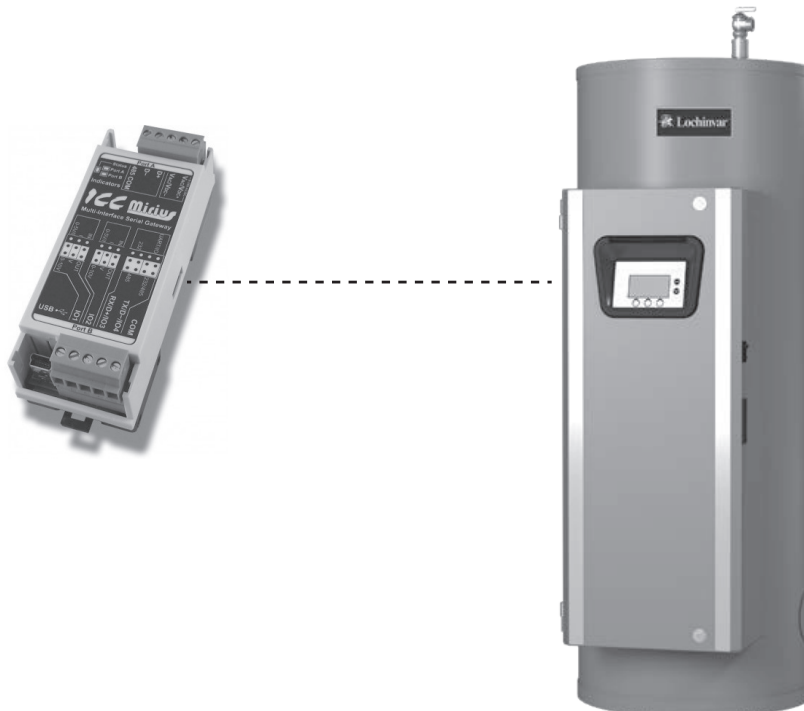

Figure 24. Compact ASME Electric Water Heaters (Virtual BACnet device via ICC Gateway)

**PRODUCT DESCRIPTION**

The Mirius is a multiprotocol RS-485 to RS-485 gateway. The ETH-1000 is an Ethernet to RS-485 multiprotocol gateway. These products supports native BACnet, connecting directly to IP or the MS/TP LAN using baud rates of 4800, 9600, 19200, 38400, 57600, 76800, and 115200. As shipped the devices are configured as a BACnet Server.

All electronic controls provide communications via propriety protocol with the ICC Gateway. The Mirius supports BACnet MS/TP communications and the ETH-1000 supports BACnet IP to access data available at the display plus control of a limited number of points such as Operating Setpoint.

**PROTOCOL IMPLEMENTATION CONFORMANCE STATEMENT (PICS)**

**BACnet Standardized Device Profile (Annex L):**

BACnet Application Specific Controller (B-ASC)

**BACnet Interoperability**

Table 3. BACnet Interoperability Building Blocks Supported (Annex K):	
Data Sharing - ReadProperty-A (DS-RP-A)	☑
Data Sharing - ReadProperty-B (DS-RP-B)	☑
Data Sharing - ReadPropertyMultiple-B (DS-RPM-B)	☑
Data Sharing - WriteProperty-A (DS-WP-A)	☑
Data Sharing - WriteProperty-B (DS-WP-B)	☑
Data Sharing - WritePropertyMultiple-B (DS-WPM-B)	☑
Data Sharing – COV-B (DS-COV-B) (BACnet/IP only)	☑
Device Management-Dynamic Device Binding-A (DM-DDB-A)	☑
Device Management-Dynamic Device Binding-B (DM-DDB-B)	☑
Device Management-Dynamic Object Binding-B (DM-DOB-B)	☑

## BACnet / Electric Water Heaters

**Table 3. BACnet Interoperability Building Blocks Supported (Annex K):**

Device Management-Device Communication Control-B (DM-DCC-B)	<input checked="" type="checkbox"/>
Device Management – ReinitializeDevice-B (DM-RD-B)	<input checked="" type="checkbox"/>

### Segmentation Capability

Segmentation not supported.

### Data Link Layer Options

**Table 4. Data Link Layer Options**

BACnet IP (Annex J) (ETH-1000 only)	<input checked="" type="checkbox"/>
BACnet IP (Annex J), Foreign Device (ETH-1000 only)	<input checked="" type="checkbox"/>
ANSI/ATA 878.1, 2.5Mb. ARCNET (Clause 8)	<input type="checkbox"/>
ANSI/ATA 878.1, RS-485. ARCNET (Clause 8), baud rates() _____	<input type="checkbox"/>
MS/TP master (Clause9) baud rate(s): 4800, 19200, 38400, 57600, 76800, 115200	<input checked="" type="checkbox"/>
MS/TP slave (Clause9) baud rate(s): _____	<input type="checkbox"/>
Point-To-Point, EIA 232 (Clause 10), baud rate(s): _____	<input type="checkbox"/>
Point-To-Point, modem (Clause 10), baud rate(s): _____	<input type="checkbox"/>
LonTalk, (Clause 11), medium _____	<input type="checkbox"/>
Other: _____	<input type="checkbox"/>

### Device Address Binding

Is static device binding supported? (This is currently for two-way communications with MS/TP slaves and certain other devices.) YES

### Networking Options

**Table 5. Networking Options**

Router, Clause 6 – List all routing configurations	<input type="checkbox"/>
Annex H, BACnet Tunneling Router over IP	<input type="checkbox"/>
BACnet/IP Broadcast Management Device (BBMD). Does the BBMD support registrations by Foreign Devices? (ETH-1000 only)	<input checked="" type="checkbox"/>

### Character Sets

**Table 6. Character Sets Supported**

ANSI X3.4	<input checked="" type="checkbox"/>
IBMTM /MicrosoftTM DBCS	<input type="checkbox"/>
ISO 8859-1	<input type="checkbox"/>
ISO 10646 (UCS-2)	<input type="checkbox"/>
ISO 10646 (UCS-4)	<input type="checkbox"/>
JIS C 6226	<input type="checkbox"/>

Data Types

Table 7. Data Types Supported		
Object Type	Service	
	Read Property	Write Property
Analog Output Analog Value	Real	Real, Unsigned, Integer, Null
Analog Input	Real	N/A
Binary Output Binary Value	Enumerated	Enumerated, Boolean, Real, Unsigned, Integer, Null
Binary Input	Enumerated	N/A
Multi-state Output Multi-state Value	Unsigned	Real, Enumerated, Unsigned, Integer, Null
Multi-state Input	Unsigned	N/A

Object Types and Property Support

Table 8. Object Types/Property Support Table										
Property	Device	Binary Input	Binary Output	Binary Value	Analog Input	Analog Output	Analog Value	Multi Input	Multi Output	Multi Value
Object Identifier	R	R	R	R	R	R	R	R	R	R
Object Name	R	R	R	R	R	R	R	R	R	R
Object Type	R	R	R	R	R	R	R	R	R	R
System Status	R									
Vendor Name	R									
Vendor Identifier	R									
Model Name	R									
Firmware Revision	R									
App S/W Revision	R									
Protocol Revision	R									
Services Supported	R									
Object Types Supported	R									
Object List	R									
Max APDU Length	R									
Segmentation Support	R									
APDU Timeout	R									
Number APDU Retries	R									
Max master	R									
Max Info Frames	R									
Device Address Binding	R									
Database Revision	R									
Present Value		R	W	W	R	W	W	R	W	W
Status Flags		R	R	R	R	R	R	R	R	R
Event State		R	R	R	R	R	R	R	R	R
Out-of Service		R	R	R	R	R	R	R	R	
Units					R	R	R	R	R	R
Priority Array			R			R	R		R	R
Relinquish Default			R			R	R		R	R
Polarity		R	R							

R - readable using BACnet services  
W - readable and writable using BACnet services

## BACnet / Electric Water Heaters

**Table 8. Object Types/Property Support Table**

Property	Device	Binary Input	Binary Output	Binary Value	Analog Input	Analog Output	Analog Value	Multi Input	Multi Output	Multi Value
<b>Inactive Text</b>		R	R							
<b>Active Text</b>		R	R							

R - readable using BACnet services  
W - readable and writable using BACnet services

### DEVICE OBJECT LISTINGS

#### Device Objects Initial Values

**Table 9. BACnet/Electric Water Heaters Device Object**

Property Name	ID	BACnet Data Type	RW	Initial Value (Mirus)	Initial Value (ETH-1000)
Object_Identifier	75	Object Identifier	RW	Device, 520081	Device, 520081
Object_Name	77	Character String	RW	Elec Water Heater	Elec Water Heater
Object_Type	79	Enumerated	R	Device	Device
System_Status	112		R	Operational	Operational
Vendor_Name	121		R	ICC, Inc.	
Vendor_Identifier	120		R	242	
Model_Name	70		R	Mirus	ETH-1000
Firmware_Revision	44	Character String	R	V3.000	V4.001
Application_Software_Version	12		R	V3.000	V4.001
Protocol_Version	98		R	1	1
Protocol_Revision	139		R	12	12
Protocol_Services_Supported	97		R	See PICS	See PICS
Protocol_Object_Types_Supported	96		R	AI, AO, AV, BI, BO, BV, MSI, MSO, MSV	AI, AO, AV, BI, BO, BV, MSI, MSO, MSV
Object_List	76		R	See Table	See Table
Max_APDU_Length_Accepted	62		R	480	1444
Segmentation_Supported	107		R	3	3
APDU_Timeout	10		RW	1000ms	1000ms
Number_Of_APDU_Retries	73		R	3	3
Max_Master	64		RW	127	Unsupported
Device_Address_Binding	30		R	{}	{}
Local_Date	56		R	Unsupported	Unsupported
Local_Time	57		R	Unsupported	Unsupported

#### Device Objects Minimum/Maximum Values

- Not all models support all registers. Also parameter names may be different than shown here on some models.
- This table may be subject to change in the future.
- Adjustable objects are in bold and indicated by "W" (writable).
- Mirius Object names may be abbreviated to fit in 16 characters.
- Where noted, some objects implemented only in ETH-1000.

**Table 10. BACnet/Electric Water Heaters Object List**

BACnet Object Name (Description)	BACnet Object Type/Inst.	BACnet Object Property	R/W	Units	Min Value (if W)	Max Value (if W)
Firmware Ver-Rev <sup>1</sup> (Firmware Version)	Analog Input 1	Present_Value	R			
Configuration	Analog Input 2	Present_Value	R			

1. Data is encoded into the 16 bits as major revision (upper 8 bits) and minor revision (lower 8 bits).

**BACnet / Electric Water Heaters**

<b>Table 10. BACnet/Electric Water Heaters Object List</b>						
<b>BACnet Object Name (Description)</b>	<b>BACnet Object Type/Inst.</b>	<b>BACnet Object Property</b>	<b>R/W</b>	<b>Units</b>	<b>Min Value (if W)</b>	<b>Max Value (if W)</b>
Tank Temperature (Controlling (Tank) Temperature)	Analog Input 5	Present_Value	R	°C		
Lower Temperature (Lower or Secondary Temperature)	Analog Input 4	Present_Value	R	°C		
Tank Temperature (Controlling Tank Temperature algorithmically calculated)	Analog Input 5	Present_Value	R	°C		
<b>Temper Setpoint</b> (Desired Tank Temperature)	Analog Value 201	Present_Value	R/W	°C (°F)	32.2 (90)	82.2 (180)
<b>Differen!Bank1</b> (Differential Setpoint Bank 1)	Analog Value 202	Present_Value	R/W	°C (°F)	.6 (1)	11.1 (20)
<b>Differen!Bank2</b> (Differential Setpoint Bank 2)	Analog Value 203	Present_Value	R/W	°C (°F)	.6 (1)	11.1 (20)
<b>Differen!Bank3</b> (Differential Setpoint Bank 3)	Analog Value 204	Present_Value	R/W	°C (°F)	.6 (1)	11.1 (20)
<b>Differen!Bank4</b> (Differential Setpoint Bank 4)	Analog Value 205	Present_Value	R/W	°C (°F)	.6 (1)	11.1 (20)
<b>Differen!Bank5</b> (Differential Setpoint Bank 5)	Analog Value 206	Present_Value	R/W	°C (°F)	.6 (1)	11.1 (20)
Number of Cycles (Number of heating cycles)	Analog Value 209	Present_Value	R	Number		
Elapsed Time (Time heater has been powered up in Hours with two place beyond the decimal)	Analog Value 210	Present_Value	R	Hours with two places beyond the decimal.		
Elapsed Days (The number of days that the heater has been powered up)	Analog Value 211	Present_Value	R	Days		
Elapsed Hours (The hours portion that the heater has been powered up. Use with Elapsed Days)	Analog Value 212	Present_Value	R	Hours		
Heating Time (Time heater has been actually heating water in Hours with two place beyond the decimal)	Analog Value 213	Present_Value	R	Hours with two places beyond the decimal.		
Heating Days (The amount of time in number of days heater has been actually heating water)	Analog Value 214	Present_Value	R	Days		
Heating Hours (The hour's portion of the amount of time heater has been actually heating water. Use with Heating Days)	Analog Value 215	R	R	Hours		
#CCB HW Faults (CCB Hardware Fault Counter)	Analog Value 217	Present_Value	R	Number		
#Model Faults ETH-1000 ONLY (Model Fault Counter)	Analog Value 218	Present_Value	R	Number		
#Temp Probe Faults (Temperature Probe Fault Counter)	Analog Value 219	Present_Value	R	Number		
#CCB Comm Faults ETH-1000 only (Communication Fault Counter)	Analog Value 223	Present_Value	R	Number		
#ECO Faults (High temperature Energy Cut Off switch in Upper temperature probe Fault Counter)	Analog Value 224	Present_Value	R	Number		
#Powr Anode Flts (Powered Anode Alert Counter)	Analog Value 233	Present_Value	R	Number		
#Element Faults (Element Fault Counter)	Analog Value 234	Present_Value	R	Number		
#LWCO Faults (Low Water Cut Off Fault Counter)	Analog Value 235	Present_Value	R	Number		
#Element Banks Used (Number of Element Banks in Water Heater)	Analog Value 236	Present_Value	R	Number		

1. Data is encoded into the 16 bits as major revision (upper 8 bits) and minor revision (lower 8 bits).

**BACnet / Electric Water Heaters**

**Table 10. BACnet/Electric Water Heaters Object List**

<b>BACnet Object Name (Description)</b>	<b>BACnet Object Type/Inst.</b>	<b>BACnet Object Property</b>	<b>R/W</b>	<b>Units</b>	<b>Min Value (if W)</b>	<b>Max Value (if W)</b>
#Elements in Bank 1 (Number elements current is check for in bank 1)	Analog Value 237	Present_Value	R	Number		
#Elements in Bank 2 (Number elements current is check for in bank 2)	Analog Value 238	Present_Value	R	Number		
#Elements in Bank 3 (Number elements current is check for in bank 3)	Analog Value 239	Present_Value	R	Number		
#Elements in Bank 4 (Number elements current is check for in bank 4)	Analog Value 240	Present_Value	R	Number		
#Elements in Bank 5 (Number elements current is check for in bank 5)	Analog Value 241	Present_Value	R	Number		
#Banks Cmd'd On (Number of Banks currently Commanded to be on)	Analog Value 242	Present_Value	R	Number		
Bank On Time ETH-1000 only (Time bank has been powered up in Hours with two place beyond the decimal)	Analog Value 243	Present_Value	R	Hours with two places beyond the decimal.		
Bank1 On Days (The amount of time in number of days bank has been actually heating water)	Analog Value 244	Present_Value	R	Days		
Bank1 On Hours (The hour's portion of the amount of time bank has been actually heating water. Use with Bank1 On Days)	Analog Value 245	Present_Value	R	Hours		
Bank2 On Time ETH-1000 only (Time bank has been powered up in Hours with two place beyond the decimal)	Analog Value 246	Present_Value	R	Hours with two places beyond the decimal.		
Bank2 On Days (The amount of time in number of days bank has been actually heating water)	Analog Value 247	Present_Value	R	Days		
Bank2 On Hours (The hour's portion of the amount of time bank has been actually heating water. Use with Bank2 On Days)	Analog Value 248	Present_Value	R	Hours		
Bank3 On Time ETH-1000 only (Time bank has been powered up in Hours with two place beyond the decimal)	Analog Value 249	Present_Value	R	Hours with two places beyond the decimal.		
Bank3 On Days (The amount of time in number of days bank has been actually heating water)	Analog Value 250	Present_Value	R	Days		
Bank3 On Hours (The hour's portion of the amount of time bank has been actually heating water. Use with Bank3 On Days)	Analog Value 251	Present_Value	R	Hours		
Bank4 On Time ETH-1000 only (Time bank has been powered up in Hours with two place beyond the decimal)	Analog Value 252	Present_Value	R	Hours with two places beyond the decimal.		
Bank4 On Days (The amount of time in number of days bank has been actually heating water)	Analog Value 253	Present_Value	R	Days		
Bank4 On Hours (The hour's portion of the amount of time bank has been actually heating water. Use with Bank4 On Days)	Analog Value 254	Present_Value	R	Hours		

1. Data is encoded into the 16 bits as major revision (upper 8 bits) and minor revision (lower 8 bits).

**BACnet / Electric Water Heaters**

**Table 10. BACnet/Electric Water Heaters Object List**

<b>BACnet Object Name (Description)</b>	<b>BACnet Object Type/Inst.</b>	<b>BACnet Object Property</b>	<b>R/W</b>	<b>Units</b>	<b>Min Value (if W)</b>	<b>Max Value (if W)</b>
Bank5 On Time ETH-1000 only (Time bank has been powered up in Hours with two place beyond the decimal)	Analog Value 255	Present_Value	R	Hours with two places beyond the decimal.		
Bank5 On Days (The amount of time in number of days bank has been actually heating water)	Analog Value 256	Present_Value	R	Days		
Bank5 On Hours (The hour's portion of the amount of time bank has been actually heating water. Use with Bank5 On Days)	Analog Value 257	Present_Value	R	Hours		
Bank 1 Heating Cycles	Analog Value 258	Present_Value	R	Number		
Bank 2 Heating Cycles	Analog Value 259	Present_Value	R	Number		
Bank 3 Heating Cycles	Analog Value 260	Present_Value	R	Number		
Bank 4 Heating Cycles	Analog Value 261	Present_Value	R	Number		
Bank 5 Heating Cycles	Analog Value 262	Present_Value	R	Number		
<b>EMS Mode-Status</b>	Analog Value 263	Present_Value	R/W	see table 3		
Element Status (Each bit is state a separate element)	Analog Value 264	Present_Value	R	Bit 0 = Element 1 Bit 1 = Element 2 . . . Bit 14 = Element 15		
Temp Probe Open (Temperature Probe open status)	Binary Input 301	Present_Value	R	0 = Okay 1 = Open		
Temp Probe Short (Temperature Probe shorted status)	Binary Input 302	Present_Value	R	0 = Okay 1 = Shorted		
Temp Probe ECO Status (Temperature probe high temperature Energy Cut Out Status)	Binary Input 313	Present_Value	R	0=Open Switch 1=Closed Switch		
Safety Relay Feedback	Binary Input 321	Present_Value	R	0=Open 1=Closed		
Tank Full (LWCO)	Binary Input 322	Present_Value	R	0=Open Switch 1=Closed Switch		
AC Input1 T'stat (External Enable 1)	Binary Input 323	Present_Value	R	0=Open 1=Closed		
AC Input2 T'stat (External Enable 2)	Binary Input 324	Present_Value	R	0=Open 1=Closed		
Bank1 Output Status	Binary Output 405	Present_Value	R	0=Off 1=On		
Bank2 Output Status	Binary Output 406	Present_Value	R	0=Off 1=On		
Bank3 Output Status	Binary Output 407	Present_Value	R	0=Off 1=On		
Bank4 Output Status	Binary Output 408	Present_Value	R	0=Off 1=On		
Bank5 Output Status	Binary Output 409	Present_Value	R	0=Off 1=On		
Alarm Condition	Binary Value504	Present_Value	R	0=False 1=True		
Output Relay Status	Binary Value 505	Present_Value	R	0=Relay Off 1=Relay On		
System In Fault	Binary Value 504	Present_Value	R	0 = Okay 1 = In Fault	0	1

1. Data is encoded into the 16 bits as major revision (upper 8 bits) and minor revision (lower 8 bits).

## BACnet / Electric Water Heaters

**Table 10. BACnet/Electric Water Heaters Object List**

BACnet Object Name (Description)	BACnet Object Type/Inst.	BACnet Object Property	R/W	Units	Min Value (if W)	Max Value (if W)
CCB System State (Central Control Board Control State)	Multistate Value 801	Present_Value	R	See <i>Table 11</i> .		
Fault Code	Multistate Value 802	Present_Value	R	See <i>Table 13</i> .		
Alert Code	Multistate Value 803	Present_Value	R	See <i>Table 13</i>		

1. Data is encoded into the 16 bits as major revision (upper 8 bits) and minor revision (lower 8 bits).

### Central Control Board Major State Definitions

**Table 11. BACnet/Electric Water Heaters Central Control Board (CCB) State**

Value	State
0	Off (Standby)
6	Heating
8	Fault

### Energy Management System (EMS) Control

Commercial Electric water heaters with Xi controls use a single bit setting method. Within the EMS Mode-Status point one bit command (bit 15) sets it in EMS mode, and other ends EMS mode. Once in EMS mode, another bit command (bit 0) enables heating another disables heating.

Once in EMS mode the EMS Mode Refresh command must be periodically issued which clears a third bit (bit 14) to maintain EMS mode, otherwise the heater will end EMS mode and resume normal operation.

**Table 12. BACnet/Electric Water Heaters Energy Management System (EMS) Control**

Decimal	Hex	Value	Response
3841	0x0F01	Put into EMS Mode <sup>^</sup>	49152 / 0xC000
0000	0x0000	EMS Disable heating <sup>^</sup>	49152 / 0xC000
0001	0x0001	EMS Enable heating <sup>^</sup>	49153 / 0xC001
3584	0x0E00	EMS Mode Refresh <sup>^</sup> (must write within 30 seconds or EMS mode ends.) 15 seconds or less recommended	49152 / 0xC000 or 49153 / 0xC001 depending on whether or not heating is enabled.

Notes:

The start of a heating also depend on other factors like tank temperature dropping below Setpoint – Differential and External T<sup>’</sup>stat call for heat if that option is enabled.

<sup>^</sup>Depending on when you poll the register, you may read bit 14 as 1 which is why a “C” (in hexadecimal form) might briefly reply with “8”. This is due to the control setting this bit and if it not cleared periodically by the BACnet command, heating is disabled.

After disabling EMS mode with write of 3840, read back might have bits 14 and 1 possibly still set. To make sure these bits are clear, write a 0000 to clear bit 1 and 3584 to clear bit 14.

### Fault Codes and Warnings

**Note:** Any Fault not listed is an internal CCB failure fault.

**Table 13. BACnet/Electric Water Heaters Fault codes and Warnings**

Index Range (Decimal)	Value
1	1
1	6
24	Incorrect Model

<b>Table 13. BACnet/Electric Water Heaters Fault codes and Warnings</b>		
<b>Index Range (Decimal)</b>		<b>Value</b>
51	56	Power Monitor
69	72	Temperature Probe Open or Short
153	154	Communications Fault
165		High temperature ECO (Energy Cut Off)
171		Low Water Cut-Off
175		Safety Relay Closed fault
176	188	CCB internal errors
193	194	Processor Clock
198	201	Non-volatile Memory
205	217	Powered Anode
431		Safety Relay Opened fault
1037	1037	Element Open Warning

MODBUS / ELECTRIC WATER HEATERS

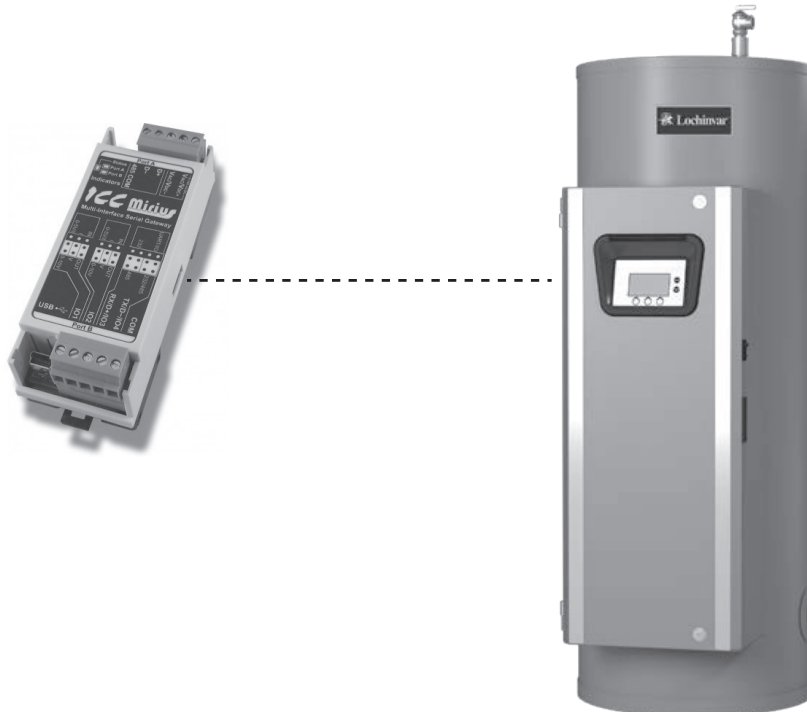

Figure 25. Custom and Gold Xi™ Series Electric Water Heaters (Virtual Modbus device via ICC Gateway)

**PRODUCT DESCRIPTION**

Commercial Electric water heaters are designed for commercial hot water applications. The controls provide easy to read, plain English configuration and diagnostics. All electronic controls provide communications via propriety protocol with the ICC Gateway. The Mirius supports Modbus RTU communications and the ETH-1000 supports Modbus/TCP to access data available at the display plus control of a limited number of points such as Operating Setpoint.

**ELECTRIC WATER HEATER REGISTER LISTINGS**

**Modbus Electric Water Heaters Register Properties**

- Not all models support all registers. Also parameter names may be different those shown here on some models.
- This table may be subject to change in the future.
- Adjustable objects are in bold and indicated by “W” (writable).

Table 14. ModBus / Electric Water Heaters Register List					
Register Name (Description)	Register Type	R/W	Units/Format	Min Value (if W)	Max Value (if W)
Firmware Ver-Rev <sup>1</sup> (Firmware Version)	Input Register 1	R			
Configuration	Input Register 2	R			
Tank Temperature (Controlling (Tank) Temperature)	Input Register 6	R	°C x 512		
<b>Setpoint Temperature</b>	Holding Register 6	R/W	°C x 512 (°F)	32.2 (90)	87.7 (190)
<b>Differential Bank 1</b>	Holding Register 207	R/W	°C x 512 (°F)	.6 (1)	11.1 (20)
<b>Differential Bank 2</b>	Holding Register 208	R/W	°C x 512 (°F)	.6 (1)	11.1 (20)

1. Data is Version (upper 8 bits) and Revision (lower 8 bits).  
 2. Data stored in two 16 bit registers “Big Endian” (Higher order bits in lower register number)  
 3. Hours and Days used together derived from Time (hours x 100) i.e. Elapsed Time of 13612.24 hours in “Days” and “Hours” = 567 days, 4 hours.

Table 14. ModBus / Electric Water Heaters Register List					
Register Name (Description)	Register Type	R/W	Units/Format	Min Value (if W)	Max Value (if W)
Differential Bank <sup>3</sup>	Holding Register 209	R/W	°C x 512 (°F)	.6 (1)	11.1 (20)
Differential IBank <sup>4</sup>	Holding Register 210	R/W	°C x 512 (°F)	.6 (1)	11.1 (20)
Differential Bank <sup>5</sup>	Holding Register 211	R/W	°C x 512 (°F)	.6 (1)	11.1 (20)
CCB Control State	Input Register 1040	R	See Table 15.		
EMS Mode-Status	Holding Register 90	R/W	See Table 16.		
Fault Code	Input Register 1041	R	See Table 17.		
Alert Code	Input Register 1042	R	See Table 17.		
Number of Banks in Heater	Input Register 201	R			
Number of Banks Commanded On	Input Register 213	R			
Bank 1 Status	Input Status 3873	R	0=Off 1=On		
Bank 2 Status	Input Status 3874	R	0=Off 1=On		
Bank 3 Status	Input Status 3875	R	0=Off 1=On		
Bank 4 Status	Input Status 3876	R	0=Off 1=On		
Bank 5 Status	Input Status 3877	R	0=Off 1=On		
Element Status	Input Register 219	R	Bit 0=Element 1 Bit 1=Element 2 . . Bit 14=Element 14		
Tank Full (LWCO)	Input Status 150	R	0=Open Switch 1=Closed Switch		
AC Input 1 T'stat	Input Status 3428	R	0=Open 1=Closed		
AC Input 2 T'stat	Input Status 3429	R	0=Open 1=Closed		
Alarm Condition	Input Status 3441	R	0=Open 1=Closed		
Alarm Relay Status	Input Status 3443	R	0=Open 1=Closed		
Safety Relay Feedback	Input Status 147	R	0=Open 1=Closed		
Temperature Probe Open	Input Status 65	R	0=False 1=True		
Temperature Probe Short	Input Status 66	R	0=False 1=True		
Temperature Probe ECO Status	Input Status 156	R	0=Open 1=Closed		
Number of Cycles <sup>2</sup>	Input Registers 1000 - 1001	R			
Elapsed Time <sup>2</sup>	Input Registers 1002 - 1003	R	Hours x 100		
Elapsed Days <sup>3</sup>	Input Register 1004		Days		
Elapsed Hours <sup>3</sup>	Input Register 1005		Hours		
Heating Time <sup>2</sup>	Input Registers 1006 - 1007		Hours x 100		
Heating Days <sup>3</sup>	Input Register 1008	R	Days		

1. Data is Version (upper 8 bits) and Revision (lower 8 bits).  
 2. Data stored in two 16 bit registers "Big Endian" (Higher order bits in lower register number)  
 3. Hours and Days used together derived from Time (hours x 100) i.e. Elapsed Time of 13612.24 hours in "Days" and "Hours" = 567 days, 4 hours.

**Modbus / Electric Water Heaters**

**Table 14. ModBus / Electric Water Heaters Register List**

<b>Register Name (Description)</b>	<b>Register Type</b>	<b>R/W</b>	<b>Units/Format</b>	<b>Min Value (if W)</b>	<b>Max Value (if W)</b>
Heating Hours <sup>3</sup>	Input Register 1009	R	Hours		
Bank 1 Number of Heat Cycles <sup>2</sup>	Input Registers 1030 - 1031	R			
Bank 2 Number of Heat Cycles <sup>2</sup>	Input Registers 1032 - 1033	R			
Bank 3 Number of Heat Cycles <sup>2</sup>	Input Registers 1034 - 1035	R			
Bank 4 Number of Heat Cycles <sup>2</sup>	Input Registers 1036 - 1037	R			
Bank 5 Number of Heat Cycles <sup>2</sup>	Input Registers 1038 - 1039	R			
Bank 1 Heating Time <sup>2</sup>	Input Registers 1010 - 1011		Hours x 100		
Bank 1 Heating Days <sup>3</sup>	Input Register 1012	R	Days		
Bank 1 Heating Hours <sup>3</sup>	Input Register 1013	R	Hours		
Bank 2 Heating Time <sup>2</sup>	Input Registers 1014 - 1015	R	Hours x 100		
Bank 2 Heating Days <sup>3</sup>	Input Register 1016	R	Days		
Bank 2 Heating Hours <sup>3</sup>	Input Register 1017	R	Hours		
Bank 3 Heating Time <sup>2</sup>	Input Registers 1018 - 1019	R	Hours x 100		
Bank 3 Heating Days <sup>3</sup>	Input Register 1020	R	Days		
Bank 3 Heating Hours <sup>3</sup>	Input Register 1021	R	Hours		
Bank 4 Heating Time <sup>2</sup>	Input Registers 1022 - 1023	R	Hours x 100		
Bank 4 Heating Days <sup>3</sup>	Input Register 1024	R	Days		
Bank 4 Heating Hours <sup>3</sup>	Input Register 1025	R	Hours		
Bank 5 Heating Time <sup>2</sup>	Input Registers 1026 - 1027	R	Hours x 100		
Bank 5 Heating Days <sup>3</sup>	Input Register 1028	R	Days		
Bank 5 Heating Hours <sup>3</sup>	Input Register 1029	R	Hours		
CCB Hardware Fault Counter	Input Register 53	R			
Module Fault Counter	Input Register 54	R			
Temperature Probe Fault Counter	Input Register 55	R			
CCB Communication Fault Counter	Input Register 69	R			
ECO Fault Counter	Input Register 70	R			
LWCO (Low Water Cutoff) Fault Counter	Input Register 80	R			
Powered Anode Fault Counter	Input Register 83	R			
Element Banks Used	Input Register 201	R			
Element Fault Counter	Input Register 242	R			
Elements in Bank 1	Input Register 202	R			
Elements in Bank 2	Input Register 203	R			
Elements in Bank 3	Input Register 204	R			
Elements in Bank 4	Input Register 205	R			
Elements in Bank 5	Input Register 206	R			

1. Data is Version (upper 8 bits) and Revision (lower 8 bits).

2. Data stored in two 16 bit registers "Big Endian" (Higher order bits in lower register number)

3. Hours and Days used together derived from Time (hours x 100) i.e. Elapsed Time of 13612.24 hours in "Days" and "Hours" = 567 days, 4 hours.

**Central Control Board Major State Definitions**

Table 15. ModBus / Electric Water Heaters Central Control Board (CCB) State	
Value	State
0	Off (Standby)
6	Heating
8	Fault

**Energy Management System (EMS) Control**

Commercial Electric water heaters with Xi controls use a single bit setting method. Within the EMS Mode-Status point, one bit command (bit 15) sets it in EMS mode, and other ends EMS mode. Once in EMS mode, another bit command (bit 0) enables heating; another disables heating.

Once in EMS mode the EMS Mode Refresh command must be periodically issued which clears a third bit (bit 14) to maintain EMS mode, otherwise the heater will end EMS mode and resume normal operation.

Table 16. ModBus /Electric Water Heaters Energy Management System (EMS) Control			
Decimal	Hex	Value	Response
3840	0x0F00	No EMS control	0 / 0x000
3841	0x0F01	Put into EMS Mode <sup>^</sup>	49152 / 0xC000
0000	0x0000	EMS Disable heating <sup>^</sup>	49152 / 0xC000
0001	0x0001	EMS Enable heating <sup>^</sup>	49153 / 0xC001
3584	0x0E00	EMS Mode Refresh <sup>^</sup> (must write within 30 seconds or EMS mode ends.) 15 seconds or less recommended	49152 / 0xC000 or 49153 / 0xC001 depending on whether or not heating is enabled.

NOTE:

The start of a heating cycle also depends on other factors, like *Tank Temperature* dropping below Setpoint – Differential and *External T'stat Call for Heat* if that option is enabled.

<sup>^</sup>Depending on when you poll the register, you may read bit 14 as 1, which is why a “C” (in hexadecimal form) might briefly reply with “8”. This is due to the control setting this bit and if it not cleared periodically by the Modbus command, heating is disabled.

After disabling EMS mode with write of 3840, read-back might have bits 14 and 1 possibly still set. To make sure these bits are clear, write a 0000 to clear bit 1 and 3584 to clear bit 14.

**Fault Codes and Warnings**

**Note:** Any Fault not listed is an internal CCB failure fault.

Table 17. BACnet/Electric Water Heaters Fault Codes and Warnings				
Index Range (Decimal)		Index Range (Hex Code)		Value
0	0	0x000	0x000	Okay (No Fault)
1	6	0x001	0x006	Memory
24		0x018		Incorrect Model
51	56	0x033	0x038	Power Monitor
69	72	0x045	0x048	Temperature Probe Open or Short
153	154	0x099	0x09A	Communications Fault
165		0x0A5		High temperature ECO (Energy Cut Off)
175		0X0AF		Safety Relay Closed fault
176	188	0x0B0	0x0BC	CCB internal errors
193	194	0x0C1	0x0C2	Processor Clock
198	201	0x0C6	0x0C9	Non-volatile Memory
205	217	0x0CD	0x0D9	Powered Anode
431		0x1AF		Safety Relay Opened fault
1037	1037	0x40D		Element Open Warning

## ICC PROGRAM INFORMATION

For programming information or model compatibility contact:

The Electronics Group at 888-928-3702 select option 1 (this will ring on the iCOMM line).

Copyright © 2021. All rights reserved.

[www.hotwater.com](http://www.hotwater.com) | 800-527-1953 Toll-Free USA |  
500 Tennessee Waltz Parkway  
Ashland City, TN 37015