

ISSUE DATE: 7/96

**OPERATIONS AND MAINTENANCE MANUAL
REPLACEMENT PARTS LIST
FOR:**



LOW TEMP
MANUFACTURING COMPANY

DIVISION OF LOW TEMP INDUSTRIES, INC
9192 TARA BOULEVARD P.O. BOX 795 JONESBORO, GEORGIA 30237
TELEPHONE: (770) 478-8803

CUSTOM FABRICATORS OF STAINLESS STEEL FOOD SERVICE EQUIPMENT

THIS MANUAL COVERS CONVEYOR SYSTEMS MANUFACTURED AFTER JULY 1, 1996. FOR OLDER MODELS SOME PARTS AND CONSTRUCTIONS MAY VARY. FOR QUESTIONS CALL THE FACTORY AT 770-478-8803, FAX. 770-471-3715.

ALL OF THE LOW TEMP SYSTEMS ARE LISTED BY UNDERWRITERS LABORATORIES FOR SAFETY AND CLASSIFIED BY UNDERWRITERS LABORATORIES FOR SANITATION UNDER NSF STANDARD NO. 2.

SAFETY NOTICE

THIS SYSTEM MUST BE SERVICED BY QUALIFIED ELECTRICAL MAINTENANCE PERSONNEL FAMILIAR WITH ELECTRICAL AND MECHANICAL SYSTEMS. THIS MANUAL IS DESIGNED TO GIVE GENERAL INFORMATION ON THE ELECTRICAL AND MECHANICAL OPERATION OF THIS CONVEYOR SYSTEM. THESE CONVEYOR SYSTEMS ARE CUSTOM BUILT AND THE SPECIFIC CONFIGURATION WILL VARY FROM SYSTEM TO SYSTEM. THE SYSTEM MUST BE INSTALLED PER NEC ELECTRICAL CODE AND ANY APPLICABLE PLUMBING CODES.

MODEL NUMBER CODE:

CDA-10-00-040-1B1 (SOILED DISH CONVEYOR, ½ H.P., 120 VAC SUPPLY, SINGLE 10" WIDE BELT, 40 FEET AXIAL LENGTH, ONE (1) REMOTE START STOP, WASH DOWN ONLY, SINGLE LIMIT SWITCH.

C - CONVEYOR

D - SOILED DISH (B-BUSSING) (T-TRAY MAKE UP)

A - ½ H.P. (B-3/4 H.P.) (C-1 H.P.)

A - 120V (B-208V) MAIN SUPPLY VOLTAGE

10 - WIDTH OF FIRST OR ONLY BELT

00 - WIDTH OF SECOND BELT

040 - BELT AXIAL LENGTH IN FEET

1 - QUANTITY OF ACCESSORY START/STOP STATIONS

B - WASH DOWN SYSTEM ONLY (A- ELECTRICAL RACEWAY ONLY) (C-BOTH RACEWAY AND WASH DOWN) (N-NEITHER RACEWAY OR WASH DOWN)

1 - QUANTITY OF LIMIT SWITCHES

THE CONVEYOR SYSTEMS MANUFACTURED BY LOW TEMP INDUSTRIES ARE INTENDED TO CARRY FOOD SERVICE TRAYS. THE SYSTEMS CARRY A MAXIMUM LOAD RATING OF 10 LBS.. PER FOOT WITH A MAXIMUM SPEED OF 40 FEET PER MINUTE.

BASIC ELECTRICAL OPERATION

THE STANDARD ELECTRICAL SUPPLY TO THE SYSTEM IS 120 VAC (208 V OPTIONAL). THE SYSTEM IS OPERATED THROUGH A GREEN START PUSH BUTTON CONTROL MOUNTED ON THE MAIN CONTROL PANEL; OPTIONAL START/STOP STATIONS MAY BE PROVIDED. THE POWER IS PASSED THROUGH A CONTROL RELAY WHICH PROVIDES AN ELECTRICAL INTERLOCK FOR THE PUSH BUTTONS CIRCUIT. THE AC SUPPLY IS WIRED THROUGH A SCR CONTROLLER (SEE THE SECTION ON CONVEYOR CONTROL BOARD LAYOUT) WHICH CONVERTS IT TO A VARIABLE DC VOLTAGE WHICH IS PASSED THROUGH A BREAKING CONTACT OR AND SUPPLIES POWER TO THE MOTOR. THE VOLTAGE IS VARIED THROUGH A POTENTIOMETER WHICH IS MOUNTED ON THE MAIN CONTROL PANEL. THE SYSTEM CAN BE STOPPED BY PUSHING THE RED STOP PUSH BUTTON. WHEN THIS PUSH BUTTON IS DEPRESSED THE ELECTRICAL INTERLOCK ON THE MAIN CONTROL RELAY IS OPENED. WHEN THE STOP PUSH BUTTON IS DEPRESSED THE BREAKING RELAY IS CLOSED AND THE EXCESS POWER IS PASSED OVER THE POWER RESISTOR.

ARMATURE SWITCHING (PHOTO EYE CIRCUITS)

IF THE SYSTEM IS TO BE STOPPED AND STARTED AUTOMATICALLY WITHOUT REMOVING POWER AN INHIBIT CIRCUIT IS PROVIDED ON THE MAIN CONTROL BOARD. TO THE SYSTEM CAN BE STOPPED BY CONNECTING TERMINALS "I1" AND "I2". WHEN THESE TERMINALS ARE OPENED THE SYSTEM WILL AUTOMATICALLY RESTART. THE THROUGH BEAM PHOTO EYE SWITCHES PROVIDED WITH THIS SYSTEM ARE WIRED THROUGH THE "I1" AND "I2" TERMINALS. SEE THE SECTION ON SWITCHING CIRCUITS AND PHOTO EYE LIMIT SWITCH LATER IN THIS MANUAL.

MECHANICAL SYSTEM

THE SYSTEM IS DRIVEN BY A 90 VDC PERMANENT MAGNET MOTOR WHICH IS MOUNTED TO A "C" FACED FIGHT ANGLE GEAR BOX. THE OUTPUT SHAFT OF THE GEAR BOX IS EQUIPPED WITH A TORQUE LIMITING DEVICE WITH A #50 DRIVE SPROCKET. THIS SPROCKET IS CONNECTED TO THE MAIN DRIVE SHAFT BY A STANDARD #50 5/8" PITCH ANSI CHAIN WHICH CONNECTS TO A MATING SPROCKET MOUNTED ON THE MAIN DRIVE SHAFT. THE MAIN SHAFT IS PROVIDED WITH A DRIVE SPROCKET WHICH PULLS THE CONVEYOR BELT ASSEMBLY.

THE CHAIN TENSION ON THE #50 DRIVE CHAIN IS MAINTAINED BY A "SNAP IDLER" WHICH SADDLES AROUND THE CHAIN AND PROVIDES CONSTANT CHAIN TENSION. THIS CHAIN IS A STANDARD CARBON STEEL CHAIN AND SHOULD BE LUBRICATED EVERY 30 TO 60 DAYS WITH A STANDARD CHAIN LUBE. THE MAIN DRIVE SHAFTS ARE STAINLESS STEEL AND RIDE IN BEARINGS. THESE BEARINGS SHOULD BE CHECKED EVERY 30 TO 60 DAYS AND KEPT GREASED.

THERE ARE TWO (2) DIFFERENT TYPES OF CONVEYOR BELTS USED ON THE LOW TEMP SYSTEMS. FOR STRAIGHT RUN SYSTEMS A REXNORD #821 STYLE BELT IS USED. THIS IS AN ALL PLASTIC BELT WITH STAINLESS STEEL HINGE PINS AT EVERY JOINT. SEE THE DETAIL SHEET LATER IN THIS MANUAL FOR DETAILS ON THIS BELT. FOR SYSTEMS WITH TURN A REXNORD D3873SSK10 SYSTEM IS USED. THIS SYSTEM USES A SPECIAL #60 STAINLESS STEEL BASE CHAIN WITH SIDE PINS THAT ACCOMMODATE THE 3873 SIDE FLEX SLAT WHICH SNAPS OVER THE BASE CHAIN. A MASTER LINK FOR THE #60 BASE CHAIN IS LOCATED EVERY TEN FEET. A SMALL INDENTION IS PROVIDED IN THE CENTER OF THE SLATS INDICATING THE MASTER LINK LOCATION.

THE CONVEYOR CHAIN TENSION IS MAINTAINED AT THE TAIL SECTION OF THE CONVEYOR. A TWO BOLT THREADED SYSTEM IS PROVIDED WHICH WILL MOVE THE ENTIRE TAIL SHAFT. THIS MUST BE KEPT STRAIGHT FOR THE SYSTEM TO TRACK PROPERLY. A CANTINARY SAG OF 3 TO 4 INCHES IS NORMAL. ANY MORE THAN THAT AND THE SYSTEM MAY BIND WHEN ENTERING THE RETURN GUIDE RAILS.

BELT WASH & PAN WASH SYSTEM

WARNING

NOTE! DO NOT OPEN THE WASH TANK ACCESS DOOR IF THE BELT IS MOVING. DURING NORMAL CLEANING OPERATIONS ALWAYS DEPRESS THE STOP BUTTON AND REMOVE POWER FROM THE SYSTEM.

THE PLUMBING SYSTEM PROVIDED ON THIS SYSTEM IS MADE OF CPVC PLASTIC PIPING. A MAXIMUM INLET PRESSURE OF 40 TO 60 PSI IS RECOMMENDED. THERE ARE THREE (3) SEPARATE PLUMBING CIRCUITS ON THE SYSTEM. A BELT WASH, TOP PAN WASH AND BOTTOM PAN WASH. EACH CIRCUIT HAS ITS OWN SOLENOID AND BALL VALVE.

THE BELT WASH SYSTEM PROVIDED HAS SIX (6) SPRAY HEADS LOCATED IN THE BELT WASH TANK. THESE HEADS ARE PLUMBED THROUGH A SOLENOID AND WILL OPERATE ONLY WHEN THE BELT IS MOVING. DETERGENT IS PULLED INTO THE SYSTEM BY A "DEMA" INJECTOR SYSTEM. THE VOLUME OF WATER TO THE SPRAY HEADS IS ADJUSTABLE BY A BALL VALVE LOCATED IN THE PLUMBING MANIFOLD. THIS VOLUME SHOULD BE SET AT A MINIMUM WHICH WILL HELP PREVENT OVER SPRAY FROM THE TANK. THE "DEMA" INJECTOR IS FULLY ADJUSTABLE AND THE INJECTION RATE IS BASED UPON THE TYPE OF FLUID USED. SEE THE SECTION ON THE PLUMBING COMPONENTS AND THE "DEMA" INJECTOR FOR ADJUSTMENT INSTRUCTIONS. THE WASH TANK IS PROVIDED WITH **TWO (2) REMOVABLE SCRAP BASKETS** AND SHOULD BE **CLEANED DAILY** TO REMOVE ANY NAPKINS OR LARGE OBJECTS WHICH MAY CLOG THE DRAIN SYSTEM.

THE SYSTEM IS ALSO PROVIDED WITH FLUSH HEADS ON THE TOP PAN AND DRAIN PAN. THIS WATER SYSTEM IS **NOT INTENDED TO BE A SELF CLEANING SYSTEM**. THIS SYSTEM PROVIDES A WATER SUPPLY TO ASSIST THE OPERATOR IN CLEANING THE SYSTEM.

CLEANING THE SYSTEM

THE CONVEYOR BELT AND FRAME WORK IS FABRICATED OF ALL STAINLESS STEEL. SEE THE LATER SECTION ON "HOW TO CLEAN STAINLESS STEEL" FOR TIPS ON MAINTAINING THE STAINLESS STEEL PORTIONS OF THE SYSTEM.

CAUTION

BEFORE CLEANING THE BELT ALWAYS PUSH THE RED STOP BUTTON AND REMOVE POWER FROM THE SYSTEM. NEVER USE A LOOSE RAG AROUND THE CONVEYOR BELT WHEN MOVING.

THE CONVEYOR BELT AND TROUGH AREA MUST BE HAND WIPED TO ENSURE PROPER CLEANING. THE BELT CAN BE LIFTED UP OFF THE GUIDE RAILS IN ALL AREAS EXCEPT THE TURNS AND CLEANED. THE TURNS ARE HELD IN THE GUIDE RAIL FOR MECHANICAL PURPOSES AND SHOULD BE WIPED DOWN THE BEST WAY POSSIBLE. THERE IS ADEQUATE CLEARANCE UNDER THE BELT TO PASS A RAG. REMOVE AND CLEAN THE SCRAP BASKETS LOCATED IN THE WASH TANK DAILY.

HOW TO CLEAN STAINLESS STEEL

THE FOLLOWING INFORMATION WAS TAKEN FROM A PAMPHLET BY MR. RICHARD E. PARET, STAINLESS STEEL SPECIALIST, AMERICAN IRON AND STEEL INSTITUTE.

STAINLESS STEEL IS ONE OF THE EASIEST MATERIALS TO CLEAN AND KEEP CLEAN.

THE REASONS FOR STAINLESS STEEL'S EASE OF CLEANING ARE EASY TO SEE; THEY LIE IN THE NATURE OF THE METAL ITSELF.

1. IT'S HARD, TOUGH SURFACE. STAINLESS STEEL WILL WORK HARDEN, THAT IS, THE MORE IT IS USED, THE MORE RESISTANT TO WEAR IT BECOMES. STAINLESS STEEL WILL NOT DEVELOP ROUGH SPOTS THAT HARBOR BACTERIA AND SOIL.

2. HIGH CORROSIVE RESISTANCE. STAINLESS STEEL IS PRACTICALLY UNTOUCHED BY THE CORROSIVE ATTACKS OF MOISTURE, DETERGENTS, FOOD ACIDS, BLOOD SALTS AND OTHER CORRODENTS CONNECTED WITH FOOD PREPARATION. THIS MEANS THAT STAINLESS STEEL ALWAYS HAS A BRIGHT SURFACE FREE FROM OXIDES THAT CAN AFFECT THE FLAVOR OF FOODS.

THE SECRET OF MAINTAINING STAINLESS STEEL IS FREQUENT, SCHEDULED CLEANING THAT WILL PREVENT BUILD UP OF SURFACE DEPOSITS. SURFACE DEPOSITS, IF ALLOWED TO REMAIN FOR LONG PERIODS OF TIME CAN HAM STAINLESS STEEL. STAINLESS STEEL THRIVES ON EXPOSURE TO AIR; UNDER CERTAIN CONDITIONS, THE LENGTHY DEPRIVATION OF OXYGEN BY HEAVY SOIL DEPOSITS CAN CAUSE LOCALIZED PITTING OR STAINING.

NEGLECTING THE MATERIAL IN THIS MANNER IS **DEFINITE ABUSE** WHICH EVEN STAINLESS STEEL IS NOT IMMUNE.

TWO BASIC RULES:

1. CLEAN FREQUENTLY, AND ON A FIXED SCHEDULE.
2. SELECT THE SIMPLEST METHOD.

TO REMOVE ORDINARY DIRT AND FOOD RESIDUE FROM STAINLESS STEEL EQUIPMENT THAT OPERATES AT LOW TEMPERATURES, USE ORDINARY SOAP AND WATER AND APPLY WITH A SPONGE, FIBER BRUSH OR CLOTH. TO HASTEN ACTION, ADD EITHER SODA ASH, BAKING SODA, BORAX OR ANY OF SEVERAL NON-ABRASIVE COMMERCIAL CLEANSING AGENTS.

TO REMOVE SPLATTER OR CONDENSED VAPOR WHICH HAVE "BAKED" ONTO THE EQUIPMENT, THE TREATMENT OUTLINED ABOVE IS OFTEN SUFFICIENT. IN OTHER CASES A GENTLE TO VIGOROUS POLISHING ACTION MAY BE NECESSARY.

FIRST TRY A PASTE MADE WITH WATER AND AMMONIA AS THE LIQUID AND EITHER MAGNESIUM OXIDE, FINELY POWDER PUMICE OR FRENCH CHALK AS THE SOLID. YOU CAN ALSO USE ONE OF SEVERAL COMMERCIAL CLEANERS LISTED IN THE FOLLOWING TABLE.

RUB AS GENTLY AS POSSIBLE IN THE DIRECTION OF THE POLISHING MARKS ON THE STEEL, USING A SOFT CLOTH. FOR MORE RESISTANT DEPOSITS, USE A STAINLESS STEEL SCOURING SPONGE OR STAINLESS STEEL WOOL OF THE FINEST POSSIBLE TEXTURE.

HOW TO CLEAN STAINLESS STEEL (CONT.)

WHAT NOT TO DO:

DO NOT USE COMMON STEEL WOOL, SCOURING PADS, SCRAPERS, WIRE BRUSHES, FILES OR OTHER STEEL TOOLS, SINCE THESE CAN MAR THE STAINLESS STEEL. THESE PARTICLES WILL EVENTUALLY RUST AND STAIN THE SURFACE, AND YOU MAY HAVE TO REFINISH IT.

SLIGHTLY DARKENED AREAS SOMETIMES APPEAR ON STAINLESS STEEL SURFACES WHERE HEAT HAS BEEN APPLIED DURING FABRICATION OR IN SERVICE.

THESE ARE CAUSED BY THICKENING OF THE PROTECTIVE SURFACE OF STAINLESS STEEL, AND ARE NOT HARMFUL. REMOVAL CALLS FOR ENERGETIC SCOURING, AGAIN USING A STAINLESS STEEL WOOL OR SCOURING PAD, COMBINED WITH A SCOURING POWDER OR ONE OF THE HEAT-TINT REMOVERS LISTED IN THE TABLE.

THREE RULES WILL PREVENT HEAT TINTING:

- 1) USE ONLY ENOUGH HEAT TO DO THE JOB EFFICIENTLY.
- 2) DO NOT APPLY HEAT TO EMPTY EQUIPMENT.
- 3) AVOID CONCENTRATING HEAT ON A SMALL AREA.

***** CAUTION IS ADVISED *****

IN STERILIZING STAINLESS STEEL EQUIPMENT, PAY PARTICULAR ATTENTION TO AGENTS CONTAINING CHLORINE COMPOUNDS SUCH AS POTASSIUM HYPOCHLORITE. THESE COMPOUNDS MAY BREAK DOWN AND RELEASE FREE CHLORINE, OR HYDROLYZE TO FORM HYDROCHLORIC ACID.

STAINLESS STEEL RESISTS ATTACK BY SUCH COMPOUNDS FOR UP TO TWO HOURS. SEVERE LOCALIZED PITTING MAY OCCUR FROM LONGER EXPOSURE. FOR SAFE USE OF THESE AGENTS, KEEP CONTACT TIME SHORT, FLUSH THOROUGHLY WITH WATER, AND OPERATE EQUIPMENT NORMALLY BETWEEN APPLICATIONS. USING THESE PRECAUTIONS, THE STERILIZATION PROCESS CAN BE REPEATED ANY NUMBER OF TIMES.

CLEANERS AND THEIR EFFECT ON STAINLESS STEEL

Cleaning agent	Method of Application Finish	Effect on
<p>1. Tightly adhering deposits of "baked on" spatter, oil, grease, weather stain, dyes or other light discoloration may be removed with any of the following cleaners.</p>		
Grade FFF Italian pumice whiting or bon ami	scour or rub with damp cloth	satisfactory for all finishes use light pressure on no.7
Liquid NuSteel	scour with small amount on dry cloth	satisfactory for all finishes if rubbing pressure is light
Paste NuSteel or Temp	scour with small amount on dry cloth	satisfactory for no. 4 finish. Will scratch no.7
House hold cleaners such as Old Dutch, Sunbrite, Wyandotte, Bob-O, Gold Dust and Sapolio	Rub with damp cloth	Will scratch no. 4 finish slightly
Grade F Italian Pumice	Rub with damp cloth	Will scratch no.4 finish slightly
Cooper's stainless steel polish	satisfactory Rub with damp cloth	for no. 4 finish
Allen stainless steel polish	Rub with damp cloth	scratches but leaves mirror reflection
Best effect chemical co. cleaner & Passivator	Rub with damp cloth	May scratch no.4 finish slightly

CLEANERS AND THEIR EFFECT ON
STAINLESS STEEL
(Cont.)

Cleaning agent	Method of Application	Effect on Finish
2. Heat tint or heavy discoloration with the following (see notes below)		
Allen stainless polish	Small amount on damp cloth	Excellent heat tint remover
Birdsall's "Staybright"	Rub with damp cloth	Very good for heat tint removable. Does not scratch no.4 finish but does scratch no.7
Wyandotte or Bob-O	Rub with damp cloth	Good for heat tint removal
Oxalic acid (use warm) or 5-15% nitric acid	Swab or immerse. Always follow with a 5% sodium carbonate or neutralizer rinse	Good discoloration remover
Best effect chemical co. cleaner Passivator	Rub with damp cloth	May scratch no 4 finish but leaves a clean surface
3. The following detergents and solvents are excellent removers of grease, oil and fatty acids, where swabbing or rubbing is not practical.		
4 to 6% solution of (sodium Metasilicate) (Trisodium Phosphate) (Sodium Metaphosphate) (Sodium Pyrophosphate)		All excellent removers of grease, oil, and milkstone
5-15% caustic soda (hot or cold)		Will remove grease and milkstone
4. The following organic solvents may be used for removing oils and grease deposits:		
Carbon-tetrachloride, Naphtha, Trichlorethylene Acetone, Kerosene, Gasoline, Ether, Alcohol, Benzene		No affect on finish, however, take all precautions against fire.

CLEANERS AND THEIR EFFECT ON STAINLESS STEEL

(Cont.)

NOTES: **ORDINARY WOOL OR STEEL BRUSHES SHOULD NEVER** BE USED ON STAINLESS STEEL SURFACES. PARTICLES OF STEEL MAY BECOME IMBEDDED IN THE STAINLESS STEEL SURFACE, AND RUSTING OF THESE PARTICLES WILL EVENTUALLY APPEAR AS STAINS. USE STAINLESS STEEL WOOL OR SPONGE ON STAINLESS STEEL EQUIPMENT. HEAT TINT REMOVERS WILL USUALLY SCRATCH STAINLESS STEEL SURFACES. THIS, HOWEVER, IS NECESSARY IN REMOVING HEAT TINT BY HAND. OAKITE, A FIBROUS MATERIAL, MAY BE USED IN PLACE OF METAL SPONGES OR CLOTH PADS FOR APPLYING CLEANERS AND POLISHES. THIS MATERIAL IS EFFECTIVE IN AIDING IN REMOVAL OF MILKSTONE.

FOR HEAVY HARD WATER DEPOSITS, 15-20% (BY VOLUME) NITRIC ACID IS VERY EFFECTIVE. ACID TREATMENT SHOULD BE FOLLOWED BY A THOROUGH WATER RINSE.

THE ACTION OF SOLDERING FLUXES SHOULD BE NEUTRALIZED IMMEDIATELY WITH A 5% SODIUM CARBONATE SOLUTION.

SOAP AND WATER FOLLOWED BY A WATER RINSE WILL NOT HARM STAINLESS STEEL.

UHMW
DRIVE GEAR
GUARD

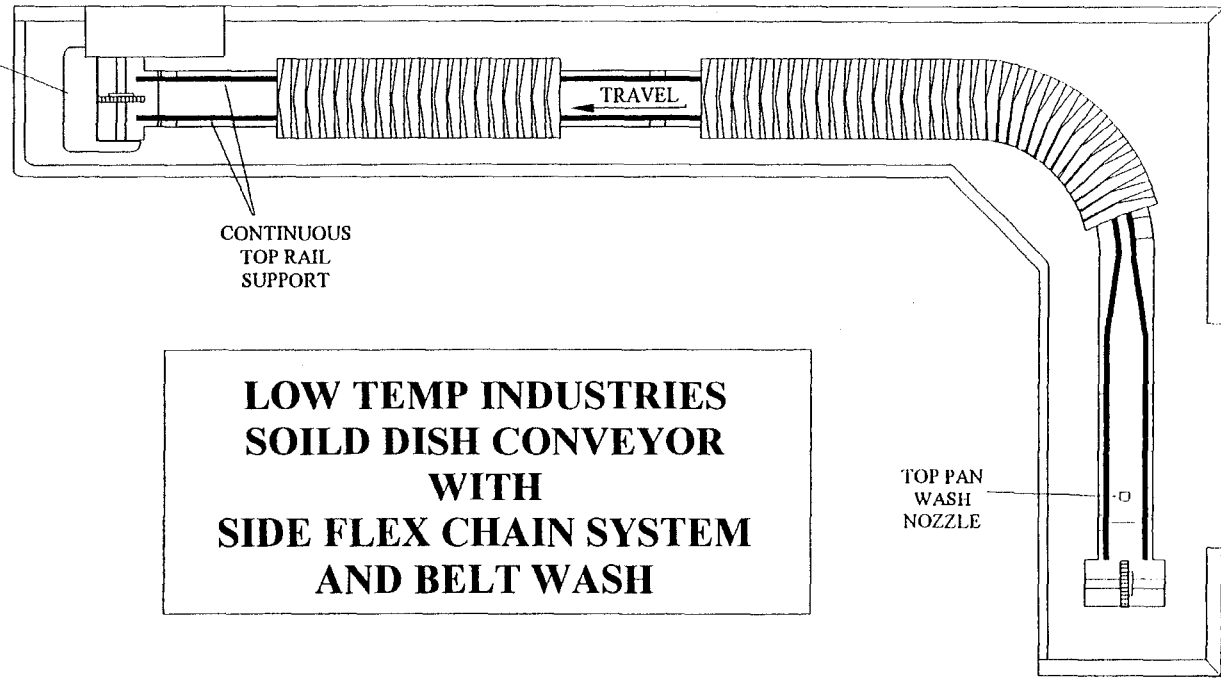

**LOW TEMP INDUSTRIES
SOILD DISH CONVEYOR
WITH
SIDE FLEX CHAIN SYSTEM
AND BELT WASH**

CONVEYOR CHAIN COMPONENTS

TOP SLAT BASE CHAIN MASTER LINK

SLAT AND BASE CHAIN ASSEMBLY
STANDARD TEN (10) FOOT LENGTH

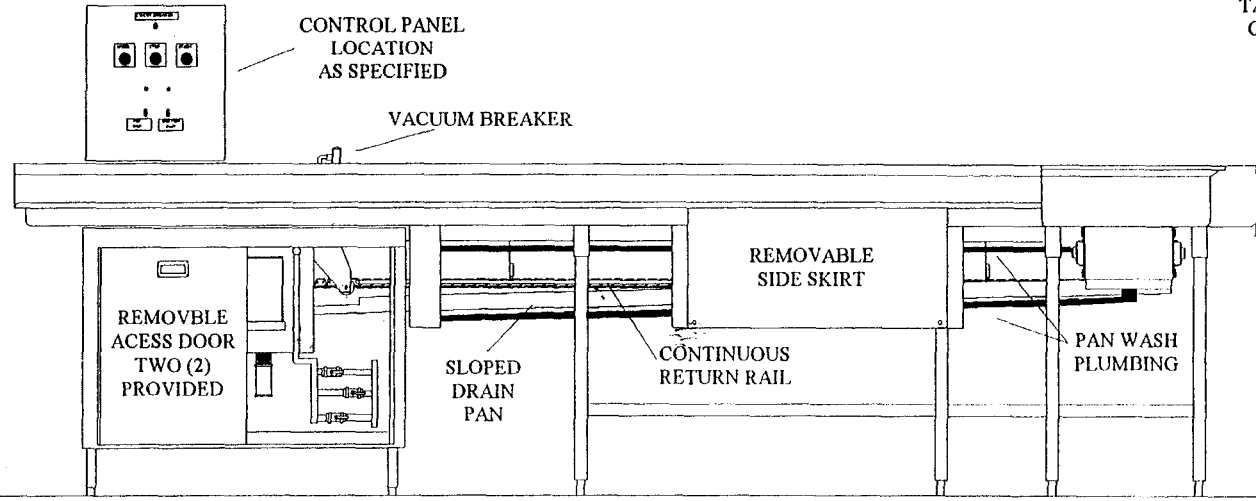

**LOW TEMP INDUSTRIES
SOILD DISH CONVEYOR
WITH
STRAIGHT RUN CHAIN SYSTEM
AND BELT WASH**

JUNE 1996

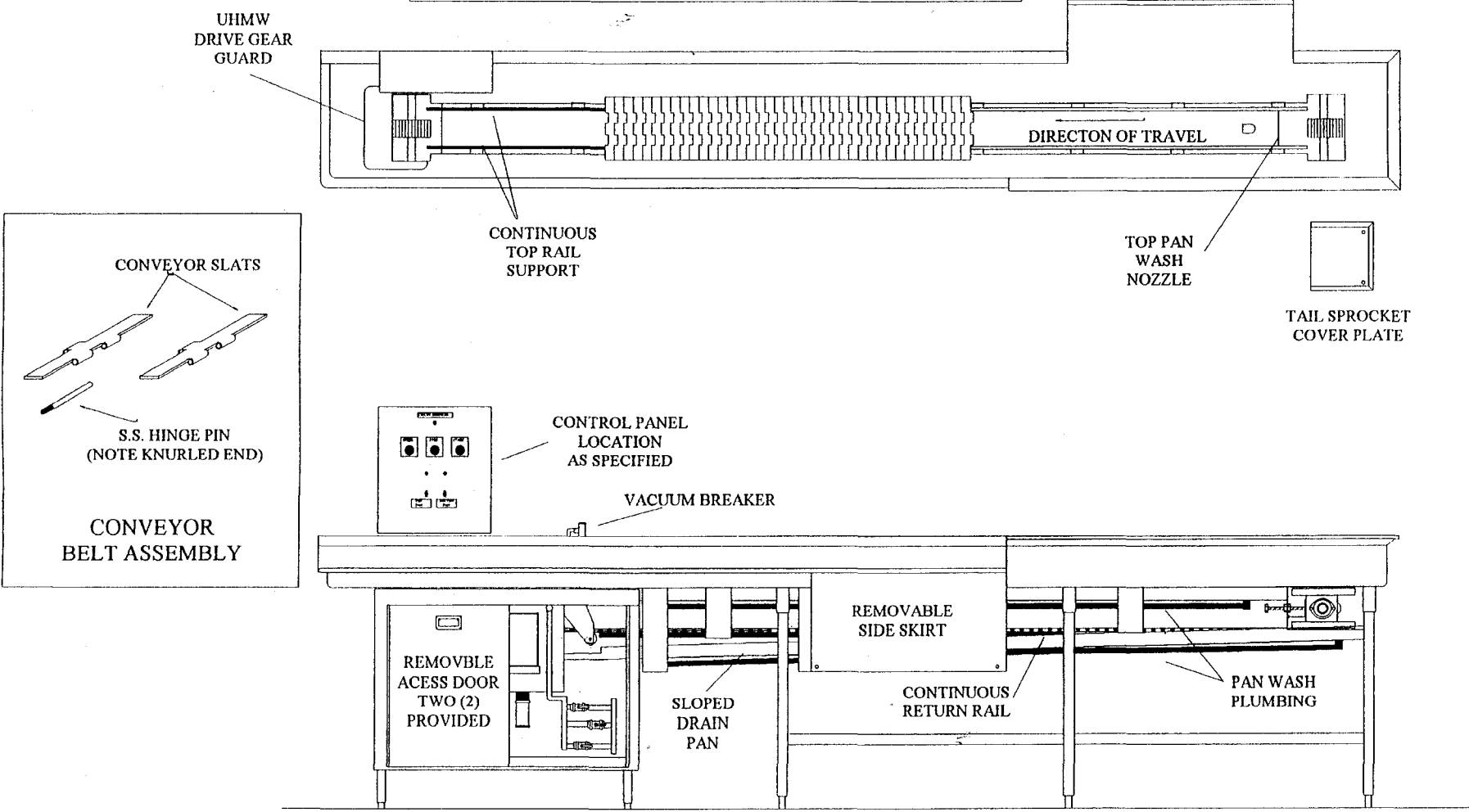

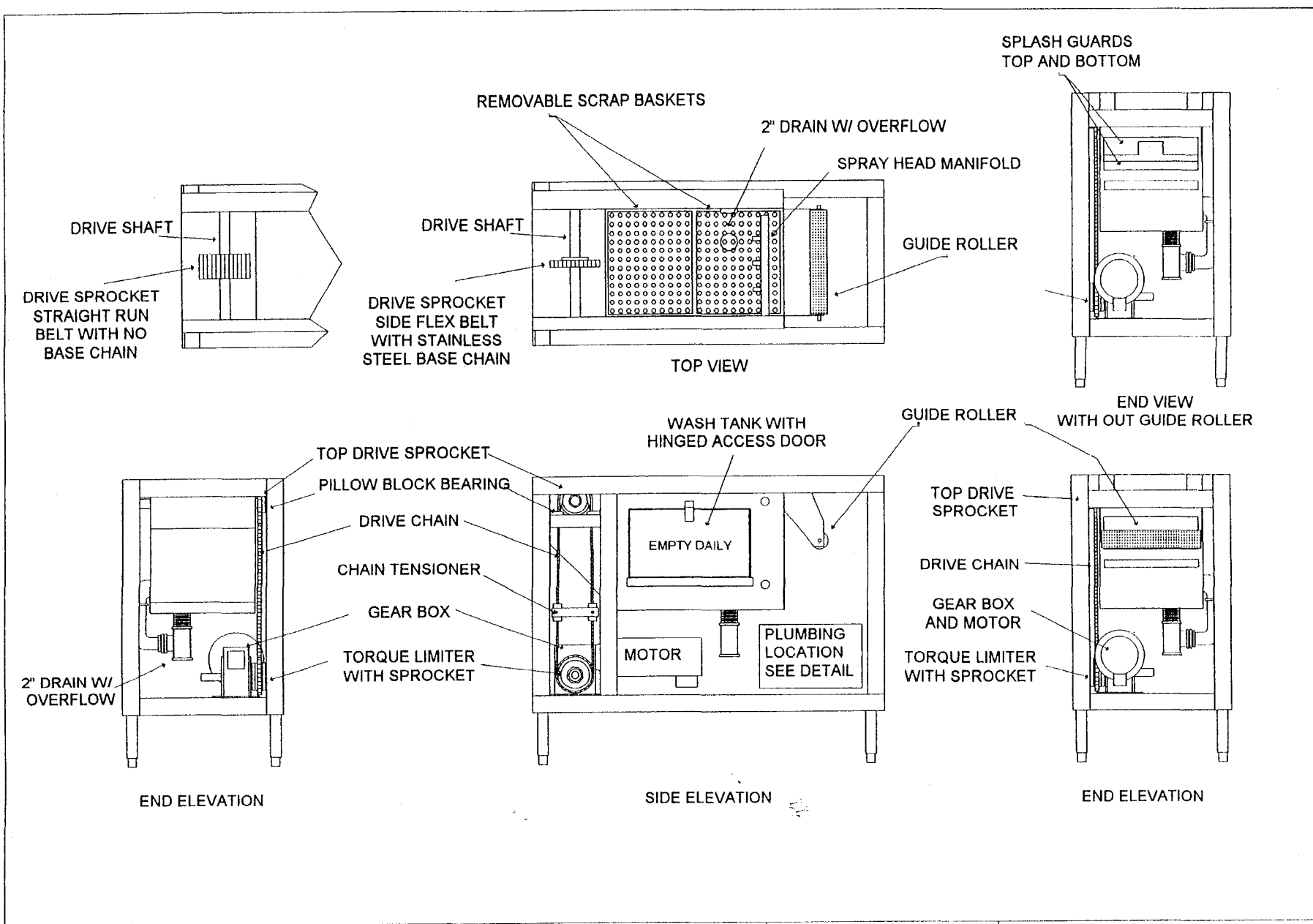

LOW TEMP INDUSTRIES INC.
JONESBORO, GEORGIA

CONVEYOR DRIVE HOUSING
WITH WASH TANK SYSTEM

DATED 4-30-96

SCALE: 3/4" = 12"

LOW TEMP INDUSTRIES
JONESBORO, GEORGIA

CONVEYOR TAIL SECTION
FOR SIDE FLEX BELT W/
S.S. BASE CHAIN

SCALE 1" = 12"

DATE: MAY 1, 1996

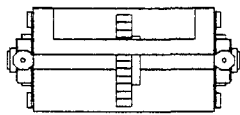
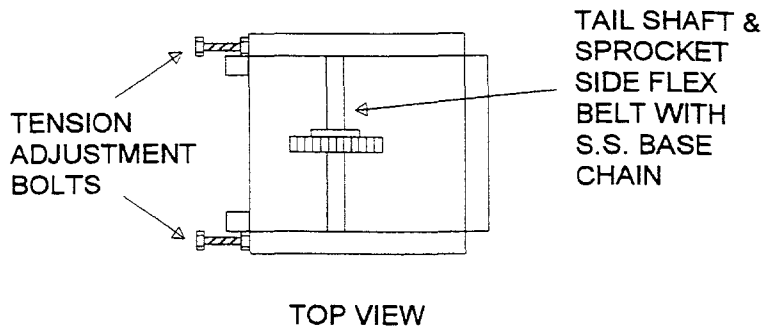

END VIEW

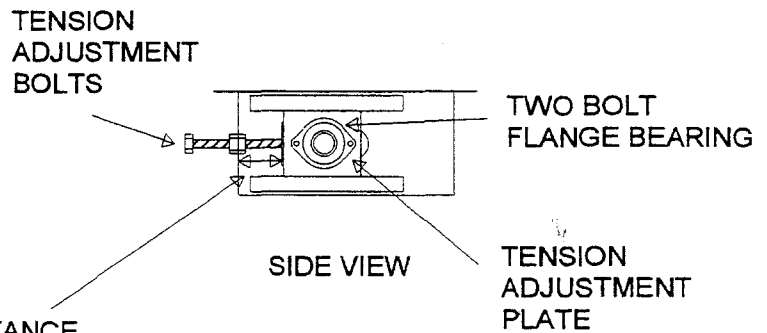

MEASURE DISTANCE
FROM BEARING PLATE
TO FRAME HOUSING
TO VERIFY ALIGNMENT

LOW TEMP INDUSTRIES
JONESBORO, GEORGIA

CONVEYOR TAIL SECTION
FOR STRAIGHT RUN BELT

SCALE 1" = 12"

DATE MAY 1, 1996

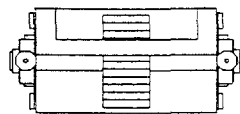
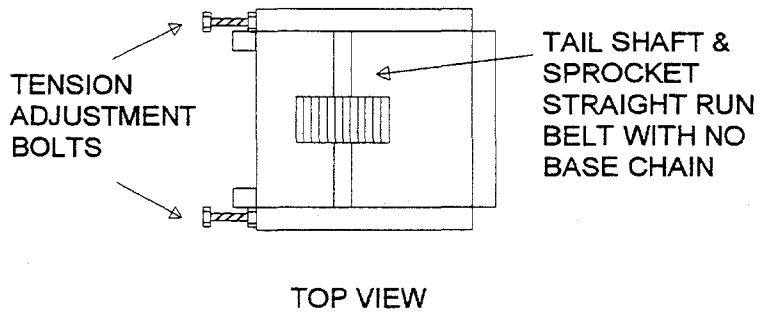

END VIEW

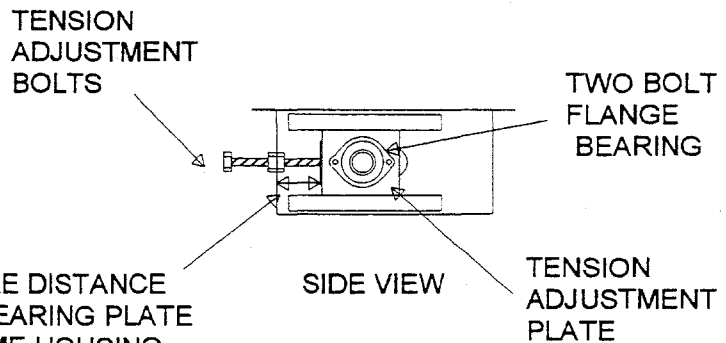

MEASURE DISTANCE
FROM BEARING PLATE
TO FRAME HOUSING
TO VERIFY ALIGNMENT

LOW TEMP INDUSTRIES CD & CB SERIES CONVEYOR DRIVE COMPONENTS (CONT.)

NOTE! THE MAIN DRIVE CHAIN WHICH CONNECTS THE CLUTCH ASSEMBLY SPROCKET TO THE TOP DRIVE SPROCKET IS A STANARD NO. 50 ROLLER CHAIN. THIS CHAIN SHOULD BE KEPT COATED WITH A GOOD COMMERCIAL GRADE CHAIN LUBRICANT TO REDUCE WARE.

THE BERAINGS ARE PROVIDED WITH GREASE FITTINGS AND SHOULD BE GREASED EVERY 30 TO 60 DAYS.

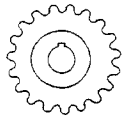
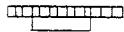

TOP DRIVE SPROCKET
#50, 19TOOTH
1-3/16" BORE
1/4" X 1/8" KEY WAY

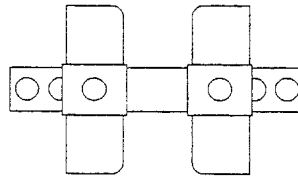

#50 SNAP IDLER
MAINTAINS CONSTANT
CHAIN TENSION ON
MAIN DRIVE CHAIN

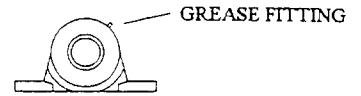

PILLOW BLOCK BEARING
1-3/16" BORE

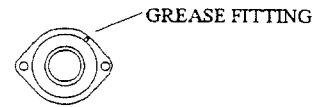

TWO (2) BOLT FLANGE BEARING
1-3/16" BORE

CONVEYOR BELT DRIVE SPROCKETS



USED WITH 3873
STYLE SIDE FLEX
SLAT WITH NO. 60
BASE CHAIN

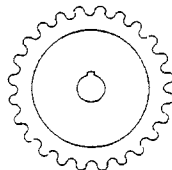

MODEL N63-23T
#60, 23 TOOTH
1-3/16" BORE



USED WITH STRAIGHT
RUN 821 STYLE BELT

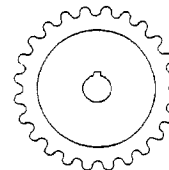

MODEL N821-25TTH
25TOOTH 821 STYLE
1-3/16" BORE
1/4" X 1/8" KEY WAY

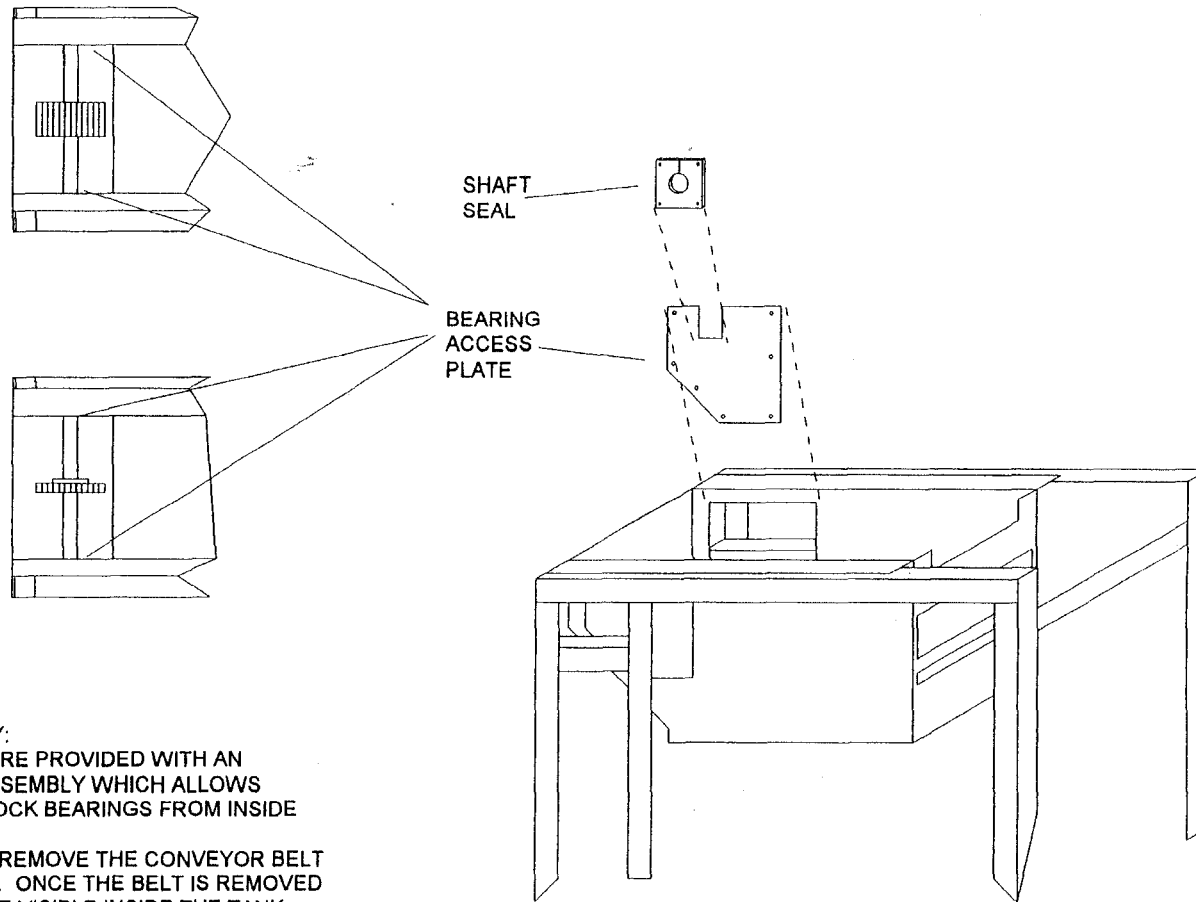

BEARING ACCESS ASSEMBLY:

THE WASH TANK SYSTEMS ARE PROVIDED WITH AN INTERNAL ACCESS PLATE ASSEMBLY WHICH ALLOWS SERVICE OF THE PILLOW BLOCK BEARINGS FROM INSIDE THE WASH TANK.

TO ACCESS THIS ASSEMBLY REMOVE THE CONVEYOR BELT FROM THE DRIVE ASSEMBLY. ONCE THE BELT IS REMOVED THE REMOVABLE PLATES ARE VISIBLE INSIDE THE TANK. REMOVE THE NUTS HOLDING THE PLATE TO THE TANK AND SLIP THE SHAFT SEAL OVER THE DRIVE SHAFT.

LOW TEMP INDUSTRIES INC.
JONESBORO, GEORGIA

CONVEYOR DRIVE HOUSING
WITH WASH TANK SYSTEM
BEARING ACCESS ASSEMBLY

DATED 6-96

SCALE: 3/4" = 12"

LOW TEMP INDUSTRIES CONVEYOR DRIVE COMPONENTS (CONT.)

CLUTCH ASSEMBLY

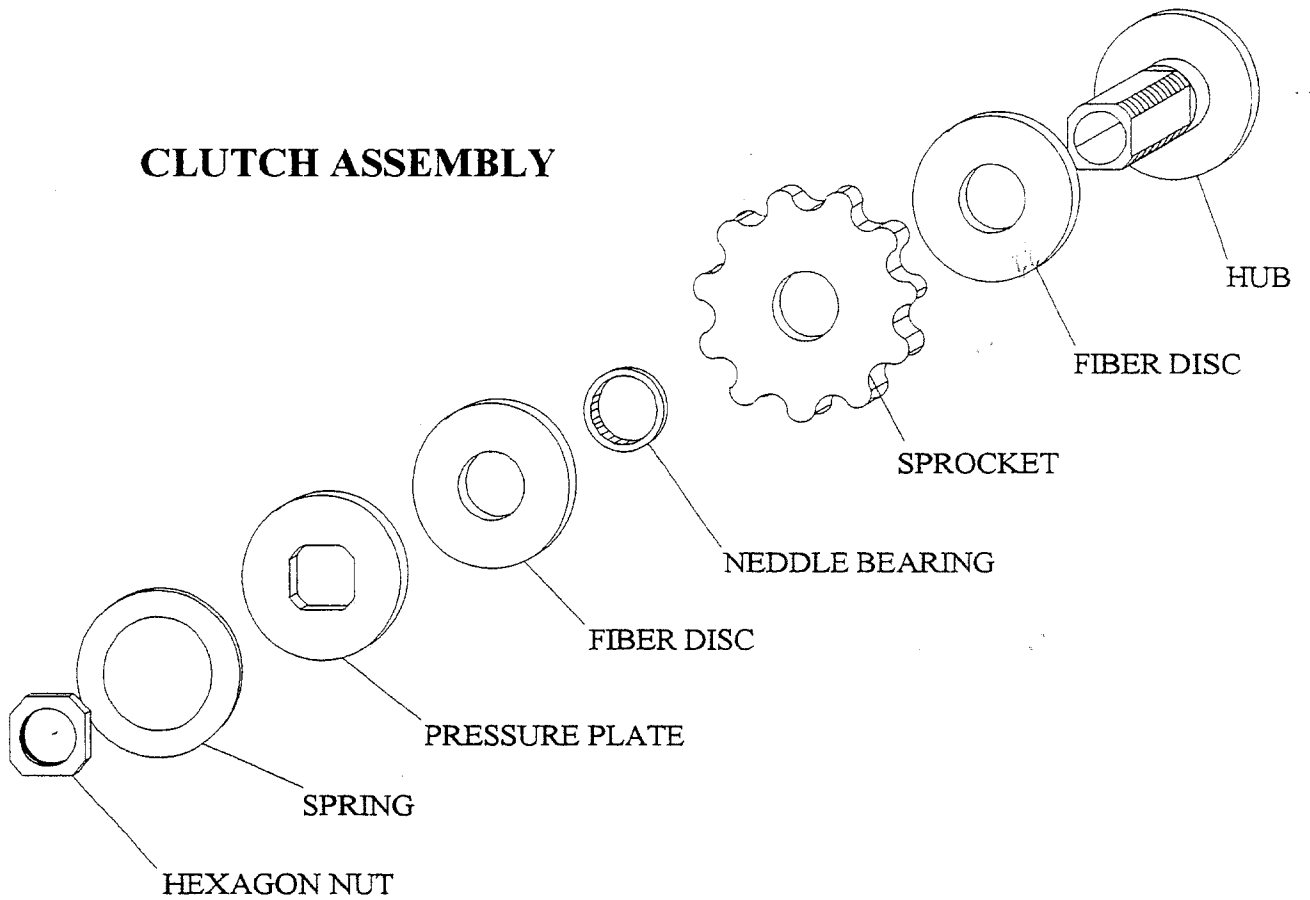

MODEL NO.	HP	BORE	TORINGTON BEARING NO.	SPROCKET
OSD-337	1/2	7/8"	B-248	50A-21G
OSD-450	3/4	1-1/4"	B-308	50A-26G
*OSD-450D	1	1-3/8"	B-308	50A-26G

* REQUIRES TWO (2) SPRINGS

LOW TEMP INDUSTRIES CONVEYOR DRIVE COMPONENTS

DC MOTOR SEPCIFICATIONS

MODEL NO.	FRAME	HP	RPM	VOLTS DC	ENCL	AG. MAX	WT.
4660-535-1543-XX	56C	1/2	1725	90	TENV	11.69	31
4660-635-2543-XX	56C	3/4	1725	90	TEFC	12.56	32
4680-735-2543-XX	56C	1	1725	90	TEFC	14.56	39

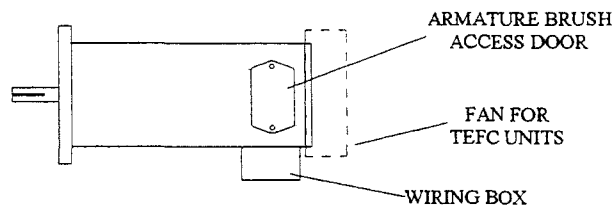

WORM GEAR REDUCER SEPCIFICATIONS

MODEL NO.	HP	OUTPUT SHAFT DIA	FRAME	OIL CAPACITY BY VOLUME (APPROX.)		WT
				WORM TOP	WORM BOTTOM	
214	1/2	7/8"	56C	1 PT	.75 PT	23
264	3/4	1-1/4"	56C	1.5 PT	1 PT	33
324	1	1-3/8"	56C	2.65 PT	1.9 PT	64

**NOTE! ALL GEAR BOXES ARE FACTORY FILLED WITH
MOBIL TYPE SHC-634 SYNTHETIC GEAR OIL
REPLACE WITH SAME TYPE GEAR OIL
DO NOT MIX MINERAL BASE GEAR OIL
WITH SYNTHETIC GEAR OIL**

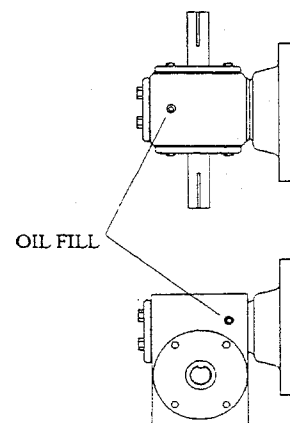

LOW TEMP INDUSTRIES

CD & CB SERIES CONVEYOR CONTROL PANEL

DOOR MOUNTED COMPONENTS

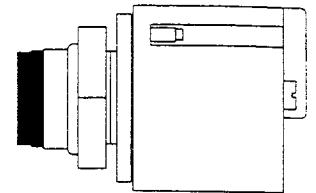
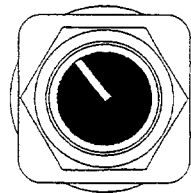
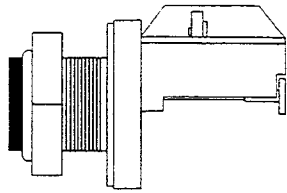
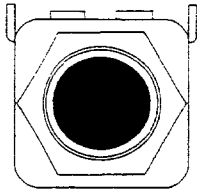

STOP PUSH BOTTON
NORMALLY CLOSED CONTACTS
RED ACTUATOR
800H-BR6D2

POTENTIOMETER
5000 OHM
800H-UR24

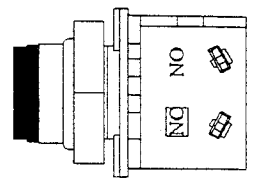
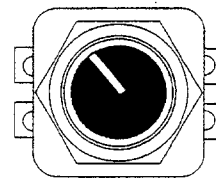
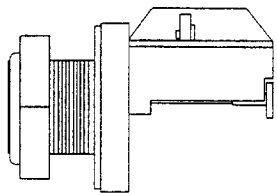
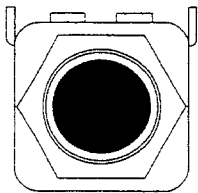

START PUSH BOTTON
NORMALLY OPEN CONTACTS
GREEN ACTUATOR
800H-AR1D1

SELECTOR SWITCH
2 POSITION MAINTAINED
10250T1311
CONTACT BLOCK
ONE (N.O.) ONE (N.C.) CONTACT
10250T1

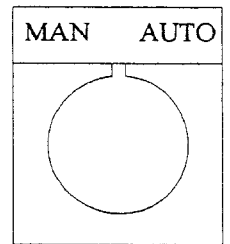
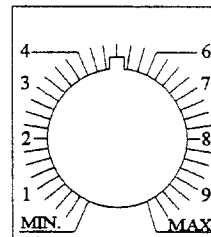
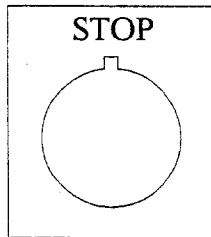
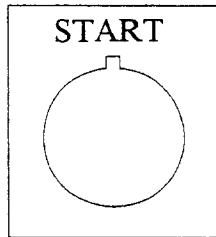

START
LEGNED PLATE
800H-W126

STOP
LEGNED PLATE
800H-W371

POTENTIOMETER
LEGNED PLATE
800H-W080

MANUAL/AUTO
LEGNED PLATE
10250TS67

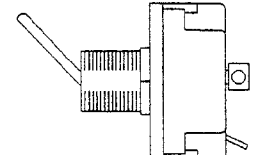
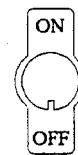
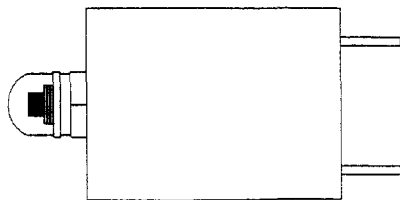

CIRCUIT BREAKER
15 AMP/ SINGLE POLE
PUSH TO TRIP/PUSH TO RESET
45-700-IG1-P10-DD
WITH PROTECTIVE BOOT
N.1.480.08



PILOT LIGHT
250V
515-5CL

BALL BAT TOGGLE SWITCH
120VAC/ 20A
0090-0001
WITH LEGEND PLATE

LOW TEMP INDUSTRIES

CD & CB SERIES CONVEYOR CONTROL PANEL

MAIN INTERIOR COMPONENTS

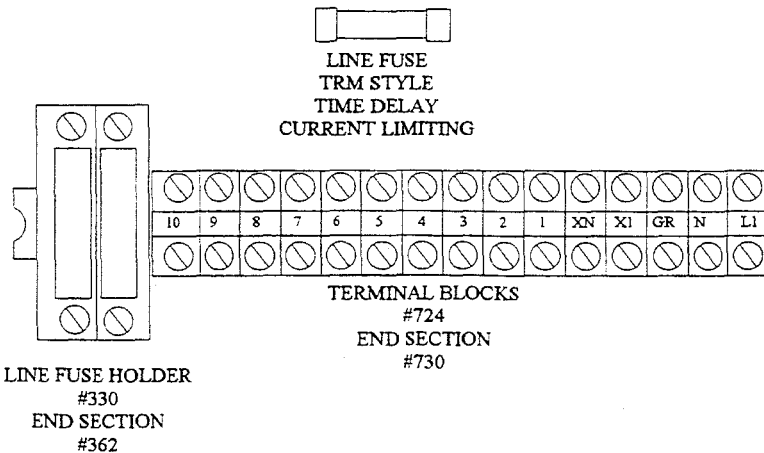
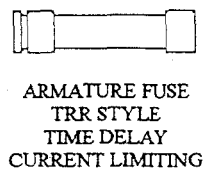
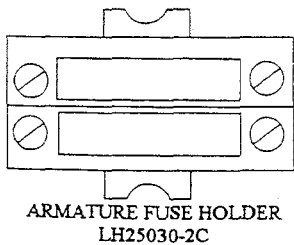
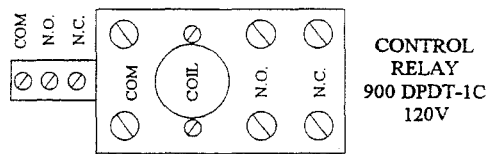
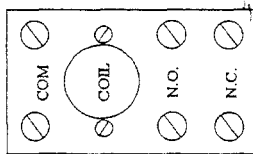
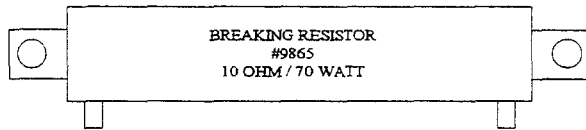
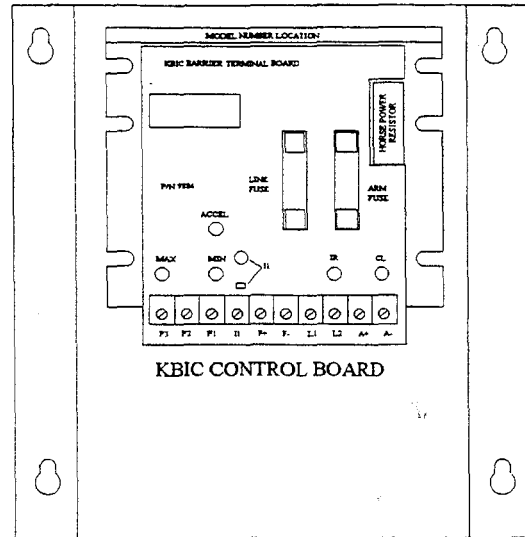
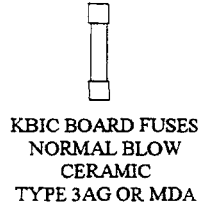
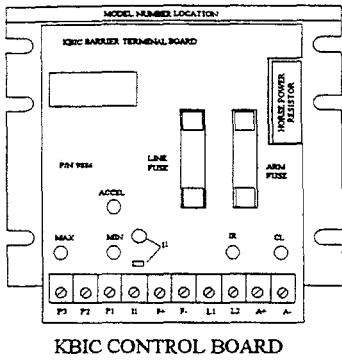

LOW TEMP INDUSTRIES CONVEYOR CONTROL PANEL OPTIONAL INTERIOR COMPONENTS

PHTOT EYE LIMIT SWITCH COMPONENTS

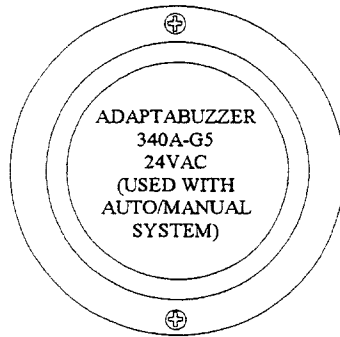

NOTE! BUZZER IS MOUNTED OUTSIDE OF CONTROL CABINET



AMPLIFIER
PA11A302 / 24VAC

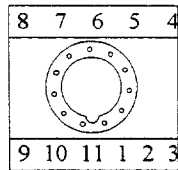

11 PIN SOCKET BASE
SR3P06

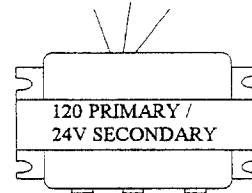

STEP DOWN
TRANSFORMER
#592

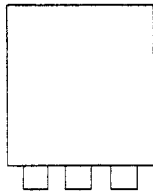

3 POLE
RELAY
BASE
RH3B-24V

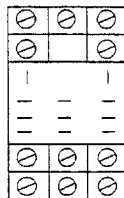

3 POLE
RELAY
BASE
SR3P-06

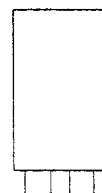

2 POLE
RELAY
BASE
RH2B-24V

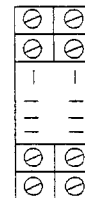

2 POLE
RELAY
BASE
SR3P-24V

LOW TEMP INDUSTRIES SOILED DISH OR BUSSING CONVEYOR PHOTO EYE LIMIT SWITCH

THRU BEAM PHOTO EYE COMPONENTS

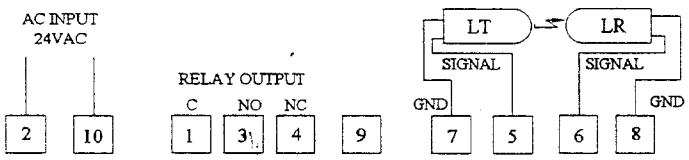
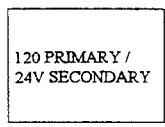
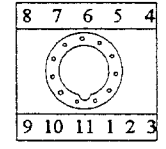
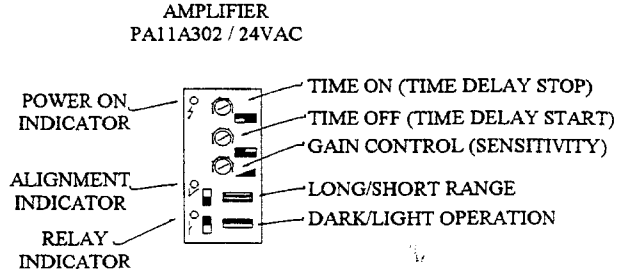
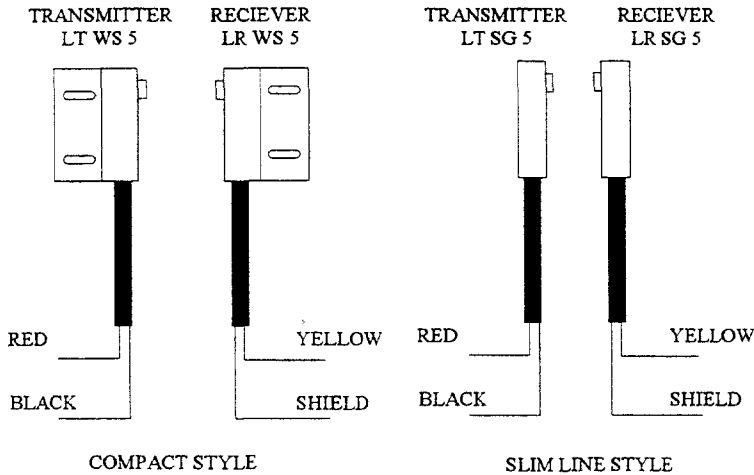

THE PURPOSE OF THE THROUGH BEAM PHOTO EYE SWITCH USED ON THIS SYSTEM IS TO PROVIDE A METHOD OF STOPPING AND STARTING THE SYSTEM AUTOMATICALLY WITHOUT HAVING TO MANUALLY PUSH THE START AND STOP BUTTONS.

TWO STYLES OF TRANSMITTER AND RECEIVER ARE AVAILABLE AND OPERATE EXACTLY THE SAME. THEY ARE SELECTED BASED UPON THE PHYSICAL MOUNTING ARRANGEMENTS AVAILABLE FOR SPECIFIC SYSTEMS. THE TRANSMITTER AND RECEIVER SHOULD BE ALIGNED AS CLOSE AS POSSIBLE BUT EXACT ALIGNMENT IS NOT REQUIRED. AN ALIGNMENT INDICATOR IS PROVIDED ON THE AMPLIFIER AND WILL ILLUMINATE WHEN THE PHOTO EYES ARE ALIGNED.

THE AMPLIFIER CONTROLS ALL OF THE FUNCTIONS OF THE PHOTO EYES. THE TOP POWER INDICATOR WILL ILLUMINATE (GREEN) WHEN POWER IS SUPPLIED TO THE AMPLIFIER. THE BOTTOM SWITCH SHOULD ALWAYS BE IN THE DARK POSITION (TOWARD DARK BAN), THE SECOND SWITCH SHOULD ALWAYS BE IN THE SHORT RANGE (ARROWS POINTING INWARD). THE THREE ADJUSTMENT POTS CONTROL THE TIME ON (TIME DELAY STOP), TIME OFF (TIME DELAY START) AND GAIN CONTROL (SENSITIVITY). THE TIME ON & TIME OFF SHOULD BE IN THE FULL COUNTER CLOCK WISE POSITION IF NO DELAYS ARE REQUIRED. THE GAIN CONTROL IS PRESET AT THE FACTORY AND SHOULD NOT NEED ADJUSTING. IF ADJUSTMENT IS REQUIRED, TURN THE GAIN TO THE FULL COUNTER CLOCK WISE POSITION AND SLOWLY TURN CLOCKWISE UNTIL THE PHOTO EYE SENSES THE TRAY. **NO TE! EXCESSIVE GAIN CAN CAUSE THE PHOTO EYE NOT TO SENSE THE OBJECT. THE GAIN CONTROL IS BASED UPON THE DENSITY OF THE OBJECT. A MINIMAL GAIN IS RECOMMENDED.**

THE SWITCHING FUNCTION OF THE PHOTO EYE IS PROVIDED THROUGH A RELAY OUTPUT. THIS OUTPUT IS CONNECTED THROUGH A SECONDARY RELAY WHICH IS WIRED THROUGH THE "11" AND "12" TERMINALS ON THE CONTROL BOARD. THE RELAY INDICATOR ON THE AMPLIFIER INDICATES THE STATUS OF THE RELAY CONTACTS.

LOW TEMP INDUSTRIES CONVEYOR CONTROL BOARD LAYOUT

SAFETY WARNING

THIS PRODUCT MUST BE INSTALLED AND SERVICED BY QUALIFIED ELECTRICAL MAINTENANCE PERSONNEL FAMILIAR WITH "SCR" CONTROLLERS AND THE HAZARDS INVOLVED. FAILURE TO DISCONNECT POWER BEFORE WIRING AND SERVICING AND TO CONNECT PROPER GROUND WIRE MAY RESULT IN AN ELECTRICAL SHOCK. IF ADJUSTMENTS ARE MADE WITH THE CONTROL DOOR OPEN AND UNDER POWER, INSULTAED ADJUSTMENT TOOLS MUST BE USED AND EYE PROTECTION SUCH AS SAFETY GLASSES MUST BE WORN.

ALL LOW TEMP CONVEYOR SYSTEMS USE THE "KBIC" SERIES DC CONTROL BOARDS.

THE CONTROL BOARD TAKES AN INPUT VOLTAGE OF 120VAC AND CONVERTS IT TO A VARIABLE OUTPUT OF 0 TO 90VDC.

THE INPUT VOLTAGE IS CONNECTED TO TERMINALS L1 AND L2. THE OUTPUT IS CONNECTED TO TERMINALS A+ AND A-. TERMINALS A+ AND A- CONNECT TO A PERMANENT MAGNET DC MOTOR

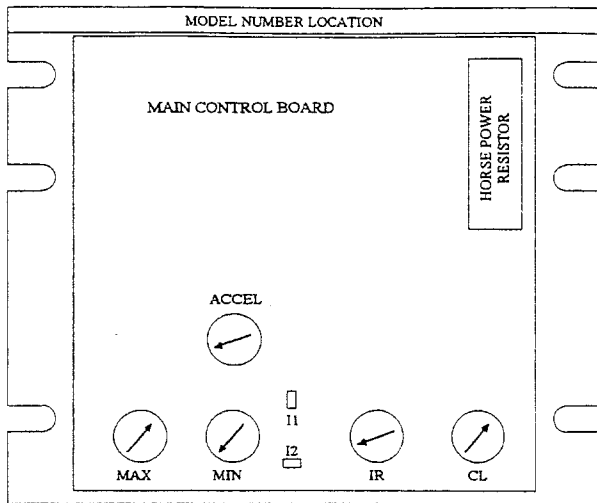

THE BOARD IS PROVIDED WITH VARIOUS TRIM POTS. LISTED BELOW ARE THE NORMAL TRIM POT SETTINGS (expressed in % of full CW rotation). SEE DETAILED INSTRUCTIONS LATER IN THIS MANUAL.

MIN (MINIMUM SPEED)	0%	
MAX (MAXIMUM SPEED)	60%	
IR (IR COMPENSATION)	15%	
CL (CURRENT LIMIT/TORQUE)	65%	
ACCEL (ACCELERATION START)	50%	

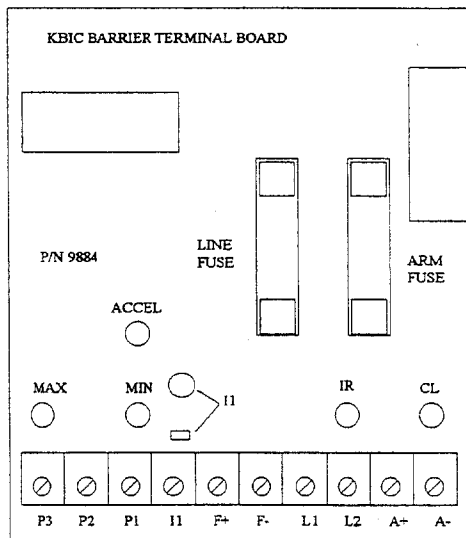

ELECTRICAL RATINGS FOR KBIC BOARDS

MODEL NUMBER	AC LINE VOLTAGE	MOTOR VOLTAGE (VDC)	AC LOAD CURRENT (RMS AMPS)	DC LOAD CURRENT (AVG. AMPS)	MAX. HP
KBIC-120	120	90-130	9.0	6.0	1/2
KBIC-125	120	90-130	12.0	8.0	3/4
KBIC-120 W/ AUX. HEAT SINK	120	90-130	18.0	12.0	1
KBIC-125 W/ AUX. HEAT SINK	120	90-130	24.0	16.0	1-1/2

NOTE: THE BARRIER BOARD ATTACHES TO THE MAIN CONTROL BOARD. TO COMPLETE CIRCUIT "11" A GRAY JUMPER MUST BE ATTACHED FROM TERMINAL "11" ON MAIN CONTROL BOARD TO TERMINAL "11" ON BARRIER BOARD. TERMINAL "12" IS LOCATED ON MAIN CONTROL BOARD.

THE OUTPUT VOLTAGE FROM THE BOARD WHICH VARIES THE MOTOR SPEED IS CONTROLLED BY A 5000 OHM (5K) POTENTIOMETER. THE POTENTIOMETER IS CONNECTED ACROSS TERMINALS P1, P2 AND P3 WITH THE CENTER WIPER CONNECTED TO P2

PLUG IN HORSEPOWER RESISTOR

A PLUG IN HORSEPOWER RESISTOR MUST BE INSTALLED TO MATCH THE KBIC BOARD TO THE MOTOR HORSEPOWER AND VOLTAGE

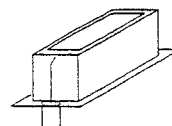

MOTOR HORSE POWER RANGE	PLUG-IN HORSEPOWER RESISTOR RESISTANCE VALUE(OHMS)	P/N
1/2	.025	9841
3/4	.015	9842
1	.01	9843

LOW TEMP INDUSTRIES CONVEYOR CONTROL BOARD INSTRUCTIONS

SAFETY WARNING

THIS PRODUCT MUST BE INSTALLED AND SERVICED BY QUALIFIED ELECTRICAL MAINTENANCE PERSONNEL FAMILIAR WITH "SCR" CONTROLLERS AND THE HAZARDS INVOLVED. FAILURE TO DISCONNECT POWER BEFORE WIRING AND SERVICING AND TO CONNECT PROPER GROUND WIRE MAY RESULT IN AN ELECTRICAL SHOCK. IF ADJUSTMENTS ARE MADE WITH THE CONTROL DOOR OPEN AND UNDER POWER, INSULATED ADJUSTMENT TOOLS MUST BE USED AND EYE PROTECTION SUCH AS SAFETY GLASSES MUST BE WORN.

ALL LOW TEMP CONVEYOR SYSTEMS USE THE "KBIC" SERIES DC CONTROL BOARDS. THESE BOARDS ARE DESIGNED TO TAKE AN INPUT VOLTAGE OF 120VAC AND CONVERT IT TO AN OUTPUT VOLTAGE WHICH CAN VARY FROM 0 TO 90 VDC. THE CONTROL BOARD IS CONNECTED TO A PERMANENT MAGNET DC MOTOR WITH AN ARMATURE VOLTAGE OF 90VDC. THE CONTROL BOARD IS EQUIPPED WITH A LINE FUSE AND ARMATURE FUSE LOCATED ON THE BARRIER BOARD. SEE THE "ELECTRICAL RATING CHART ON THE CONVEYOR CONTROL BOARD LAYOUT" PAGE FOR PROPER FUSE SIZING. THE FUSES SHOULD BE **NORMAL BLOW CERAMIC 3AG OF MDA** OR EQUIVALENT TYPE. THE SPEED OF THE MOTOR IS CONTROLLED BY A **5000 OHM (5K) POTENTIOMETER**. MOST SYSTEMS ARE PROVIDED WITH SOME TYPE OF INHIBIT DEVICE. UNLESS OTHERWISE SPECIFIED A THROUGH BEAM PHOTO EYE SYSTEM WILL BE PROVIDED. THIS SYSTEM CONNECTS THROUGH TERMINALS "I1" AND "I2" ON THE MAIN CONTROL BOARD. THIS INHIBIT CIRCUIT WILL MOMENTARILY STOP THE SYSTEM WHILE THE CIRCUIT IS CLOSED. ONCE THE CIRCUIT IS OPEN THE CONVEYOR WILL RESTART AUTOMATICALLY. SEE THE FOLLOWING SECTIONS ON SWITCHING CIRCUITS.

ADJUSTMENT AND CONTROL FUNCTIONS

THE TRIM POT DESCRIBED ON THE CONTROL BOARD LAYOUT PAGE ARE PRESET AT THE FACTORY HOWEVER IF ADJUSTMENTS ARE NECESSARY FOLLOW THE DIRECTIONS GIVEN BELOW.

ACCELERATION START: THIS TRIP POT IS FACTORY SET AT 2 SEC AND SHOULD NOT BE ADJUSTED. THIS IS THE AMOUNT OF TIME IT TAKES THE CONVEYOR TO RESTART AFTER THE INHIBIT CIRCUIT HAS BEEN OPENED.

MAXIMUM SPEED ADJUSTMENT: TURN SPEED CONTROL KNOB (POTENTIOMETER) TO FULL SPEED (MAXIMUM CW POSITION. ADJUST MAX. SPEED TRIM TO NEW DESIRED SETTING.
NOTE! THE MAXIMUM SPEED POT HAS BEEN FACTORY ADJUSTED TO PROVIDE A MAXIMUM TRAVEL RATE OR 40 FEET PER MINUTE. IF TRIM POT IS ADJUSTED **DO NOT** ADJUST ABOVE 90VDC ACROSS TERMINALS A+ AND A-. IF ARMATURE VOLTAGE IS EXCEEDED PREMATURE MOTOR FAILURE CAN OCCUR AND VOID FACTORY WARRANTY.

MINIMUM SPEED ADJUSTMENT: IF A HIGHER THAN ZERO MINIMUM SPEED IS DESIRED, READJUST THE MINIMUM SPEED BY TURNING THE SPEED CONTROL KNOB (POTENTIOMETER) TO ZERO SETTING (FULL CCW POSITION) THEN ADJUST THE MIN SPEED TRIMPOT TO THE DESIRED SETTING. ADJUSTING THE MIN. SPEED SETTING WILL AFFECT THE MAX SPEED SETTING. THEREFORE, IT IS NECESSARY TO READJUST THE MAX SPEED AFTER THE MIN SPEED, AND MAY BE NECESSARY TO REPEAT THE SEQUENCE UNTIL BOTH MIN AND MAX SPEED ARE SET TO DESIRED LEVELS.

ADJUSTMENT AND CONTROL FUNCTIONS (CONT.)

CURRENT LIMIT (CL/TORQUE ADJUSTMENT): "CL" CIRCUITRY IS PROVIDED TO PROTECT THE MOTOR AND CONTROL AGAINST OVERLOADS. THE "CL" LIMITS THE INRUSH CURRENT TO A SAFE LEVEL DURING STARTUP. THE "CL" IS FACTORY SET TO APPROXIMATELY 1.5 TIMES THE FULL LOAD RATING OF THE MOTOR ("CL" TRIMPOT IS NOMINALLY SET TO APPROXIMATELY 75% OF FULL CW ROTATION.

NOTE! THE CORRECT VALUE HORSEPOWER RESISTOR MUST BE INSTALLED IN ORDER FOR THE "CL" AND "IR" COMP TO OPERATE PROPERLY.

TO SET THE "CL" TO FACTORY SPECIFICATIONS ADJUST AS FOLLOWS:

1. SET SPEED CONTROL KNOB TO APPROXIMATELY 30-50% CW ROTATION. SET "CL" TRIMPOT TO FULL CCW POSITION.
2. CONNECT A **DC AMMETER** IN SERIES WITH THE ARMATURE LEAD.
3. LOCK SHAFT OF MOTOR (BE SURE "CL" POT IS IN FULL CCW POSITION). APPLY POWER AND ROTATE "CL" POT CW SLOWLY UNTIL AMMETER READS **1.5 TIMES** MOTOR RATING (**DO NOT EXCEED 2 TIMES MOTOR RATING**).

NOTE! IF ONLY AN **AC AMMETER** IS AVAILABLE, IT CAN BE INSTALLED IN SERIES WITH THE AC INPUT LINE. FOLLOW ABOVE INSTRUCTIONS; HOWEVER, SET AC AMPERAGE AT **.75 TIMES** MOTOR RATING.

IR COMPENSATION ADJUSTMENT: "IR" COMPENSATION IS PROVIDED TO SUBSTANTIALLY IMPROVE LOAD REGULATION. IF THE LOAD PRESENTED TO THE MOTOR DOES NOT VARY SUBSTANTIALLY, THE "IR" ADJUSTMENT MAY BE SET AT A MINIMUM LEVEL (APPROXIMATELY 1/4 OF FULL SETTING). THE CONTROL IS FACTORY ADJUSTED TO APPROXIMATELY 3% REGULATION. IF SUPERIOR PERFORMANCE IS DESIRED (LESS THAN 1% SPEED CHANGE OF BASE SPEED FROM 0 TO FULL LOAD), THEN THE "IR" COMP SHOULD BE ADJUSTED AS FOLLOWS:

NOTE! EXCESSIVE "IR" COMP. WILL CAUSE THE CONTROL TO BECOME UNSTABLE, WHICH CAUSES MOTOR COGGING (BELT WILL JUMP).

1. SET "IR" TRIMPOT TO APPROXIMATELY 25% OF CW ROTATION. RUN MOTOR UNLOADED AT APPROXIMATELY 1/3 SPEED AND RECORD RPM.
2. RUN MOTOR AT MAXIMUM LOAD AND ADJUST "IR" COMP TRIMPOT SO THAT THE MOTOR SPEED UNDERLOAD EQUALS THE UNLOADED SPEED PER STEP 1.
3. REMOVE LOAD AND RECHECK UNLOADED RPM. IF UNLOADED RPM HAS SHIFTED, REPEAT PROCEDURE FOR MORE EXACT REGULATION.

THE CONTROL IS NOW COMPENSATED TO PROVIDE MINIMAL SPEED CHANGE UNDER LARGE VARIATIONS OF APPLIED LOAD.

SWITCHING CIRCUITS

THE FOLLOWING SECTIONS CONTAINS VARIOUS WAYS THAT THE SYSTEM CAN BE TURNED "ON" AND "OFF" . THERE ARE TWO (2) BASIC WAYS TO CONTROL THE SYSTEM; "AC" LINE SWITCHING AND ARMATURE SWITCHING

"AC" LINE SWITCHING: THE KBIC CAN BE TURNED "ON" AND "OFF" BY BREAKING THE AC INPUT TO THE BOARD. THIS IS DONE BY PUSHING THE "START" AND "STOP" BUTTONS ON THE MAIN CONTROL PANEL. THE "AUTO INHIBIT" CIRCUITRY CONTAINED IN THE KBIC BOARD AUTOMATICALLY RESETS CRITICAL COMPONENTS EACH TIME THE "AC" LINE IS INTERRUPTED. THIS ALONG WITH ACCELERATION START AND "CL", PROVIDES A SMOOTH START EACH TIME THE "AC" LINE IS CONNECTED.

WARNING: DO NOT DISCONNECT AND RECONNECT THE ARMATURE WITH THE "AC" LINE APPLIED OR CATASTROPHIC FAILURE WILL RESULT.

ARMATURE SWITCHING: IF THE ARMATURE IS TO BE DISCONNECTED AND RECONNECTED WITH THE "AC" POWER APPLIED THE INHIBIT CIRCUIT MUST BE SIMULTANEOUSLY ACTIVATED AND DEACTIVATED. CONNECT "I1" AND "I2" TOGETHER TO ACTIVATE THE INHIBIT CIRCUIT.

THE LIMIT SWITCH DEVICE INSTALLED ON YOUR CONVEYOR IS WIRED THROUGH THIS "I1" AND "I2" CIRCUIT. WHEN SERVICING BE SURE TO CHECK THE WIRING DIAGRAM TO ENSURE THAT THIS CIRCUIT IS REINSTALLED PROPERLY.

THIS IS A NO LOAD INTERNAL TAP TO THE CONTROL BOARD AND IS NOT DESIGNED TO DRIVE A LOAD.

DYNAMIC BRAKE: THE SYSTEM IS PROVIDED WITH A 10 OHM / 70 WATT BREAKING RESISTOR WHICH IS CONNECTED ACROSS THE BREAKING CONTACT OR. WHEN THE "AC" LINE VOLTAGE IS BROKEN ON THE SYSTEM THE CONTACTS OF THE BREAKING RESISTOR DISTRIBUTE THE EXTRA ELECTRICAL ENERGY GENERATED BY THE MOTOR ACROSS THE RESISTOR. THIS CAUSES AN INSTANT STOP TO THE SYSTEM. NOTE! THIS DYNAMIC BRAKE IS NOT ENERGIZED DURING ARMATURE SWITCHING.

REVERSING: THE CONVEYOR BELT USED ON THESE SYSTEMS ARE NOT DESIGNED TO OPERATE IN BOTH DIRECTIONS. CHECK THE DIRECTIONAL TRAVEL ARROW ON THE BOTTOM SIDE OF THE BELT. IF FOR SERVICE PURPOSES THE BELT BECOMES JAMMED THE SYSTEM MAY BE REVERSED. TO REVERSE THE SYSTEM SWAP THE WIRE LEADS ON TERMINALS A+ AND A-. TURN THE SPEED CONTROL TO A MINIMAL SETTING AND SLOWLY REVERSE THE BELT UNTIL THE JAMB HAS BEEN CLEARED. REPLACE THE WIRES ON TERMINALS A+ AND A- TO THEIR ORIGINAL POSITION.

LOW TEMP INDUSTRIES CONVEYOR PLUMBING DIAGRAM

SPRAY NOZZLE HEAD
WITH FILTER

SPRAY NOZZLE
MOUNTING BASE



SPRAY NOZZLE
ON SPRAY BAR
SIX (6) REQUIRED

TANK SPRAY BAR
MANIFOLD WITH
SIX (6) SPRAY NOZZLES
THREE (3) TOP
THREE (3) BOTTOM

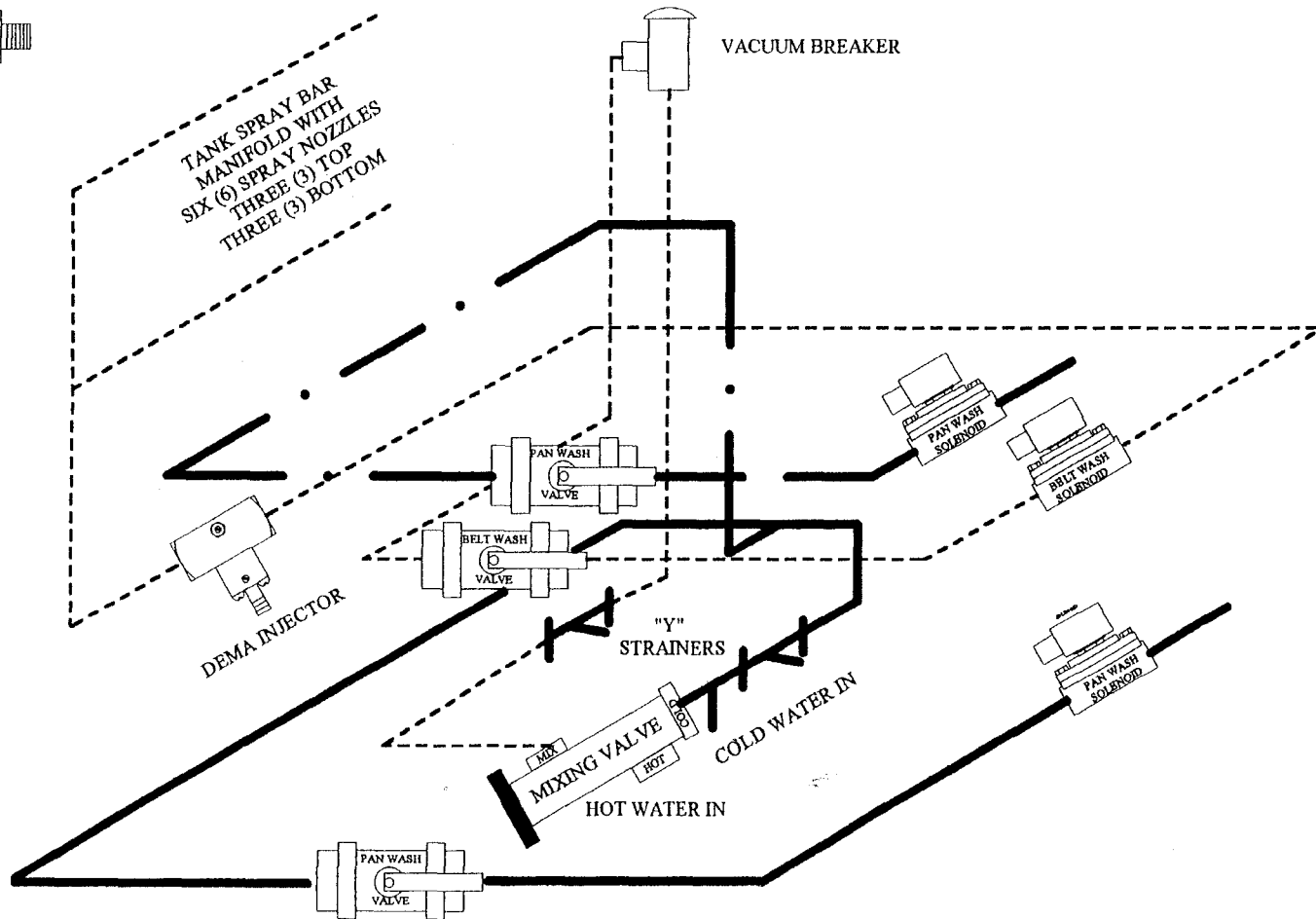

JUNE 24, 1996

LOW TEMP INDUSTRIES CONVEYOR PLUMBING COMPONENTS

JUNE 25, 1996

SPRAY NOZZLE HEAD
WITH FILTER



SPRAY NOZZLE
ON SPRAY BAR
SIX (6) REQUIRED

SPRAY NOZZLE
MOUNTING BASE

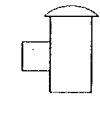

VACUUM
BREAKER

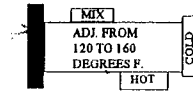

WATER
TEMPERING
VALVE

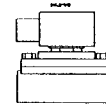

N.C. SOLENOID

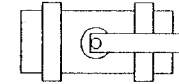

CPVC
TRUE UNION
BALL VALVE

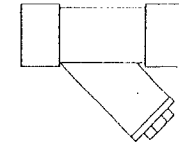

CPVC
"Y" STRAINER

WATER PRESSURE PSI	OPERATING RANGE GALLONS PER MINUTE
10	.25-2.0
20	.30-2.3
40	.37-2.9
60	.43-3.4

FLUID VISCOSITY CPS	MAXIMUM INJECTION OUNCES PER MINUTE
1	8
75	4
220	2

INSTALLATION

THE INJECTOR IS INSTALLED IN THE WATER LINE WITH THE ARROW INDICATING THE DIRECTION OF FLOW. ATTACH THE PLASTIC TUBE WITH STRAINER INTO THE SOAP CONTAINER AND CUT TUBE TO A CONVIENT LENGTH. SLIP THE OPEN END OVER INJECTOR FITTING. COVER CONTAINER BY SLIPPING METAL COVER DISC OVER TUBING. DISC MAY BE TWISTED AT THE SLIT FOR EASY APPLICATION OPERATON

DEMA MODEL 202B SINGLE STAGE INJECTOR

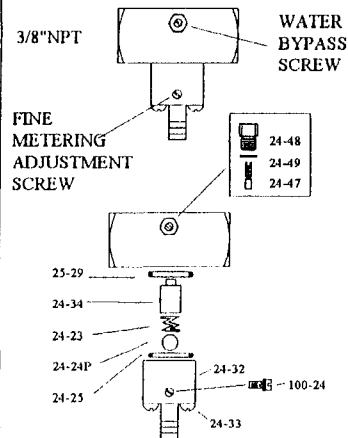

DEMA PART NO.	DESCRIPTION
24-11MP	FOOT STRAINER
24-23	CHECK VALVE SPRING
24-24P	CHECK VALVE BALL
24-25	CHECK VALVE O-RING
24-32	METERING KNOB ASSEMBLY
24-33	SCREW (#8-32, 7/8" LG., 4 REQ'D)
24-34	CHECK VALVE CORE
24-47	BY PASS SCREW
24-48	BY PASS SCREW RETAINER
24-49	O-RING
100-12	VINYL TUBING (3/8" O.D. X 8' LG.)
100-13M	DRUM PROTECTOR DISC
100-24	METERING SCREW

LOCATE "WATER BYPASS SCREW" ON MAIN BODY AND "FINE METERING ADJUSTMENT SCREW" ON LOWER ASSEMBLY WHERE TUBE ATTACHES. TURN ON WATER SUPPLY THE INJECTOR MAY DRAW MOMENTARILY AS THE SYSTEM IS FILLING BUT NORMALLY WILL STOP AS THE SYSTEM BUILDS PRESSURE. TO ACTUATE THE INJECTOR, TURN THE "BYPASS SCREW" CLOCKWISE UNTIL PRODUCT BEGINS TO BE DRAWN FROM THE CONTAINER. AFTER THE FLUID REACHES THE THE INJECTOR, THE FEED RATE MAY BE ADJUSTED TO THE DESIRED RATE BY TURNING THE BYPASS SCREW. FOR LOW INJECTION RATES, IT IS ADVISABLE TO SET THE BYPASS SCREW FOR MORE INJECTION THAN REQUIRED, THEN TURN THE FINE METERING SCREW CLOCK WISE TO REDUCE INJECTION RATE.

SERVICING

CAUTION: TURN OFF WATER SUPPLY BEFORE SERVICING. THE CHECK VALVE PARTS ARE IN THE METERING KNOB AND CAN BE CLEANED BY REMOVING THE FOUR SCREWS. THE KNOB MAY BE ROTATED IF IT IS MORE CONVIENT TO HAVE THE ADJUSTMENT SCREW ON ANOTHER SIDE OF THE INJECTOR. AS WITH ANY INJECTOR IF SPRAY JETS BECOME CLOGGED OR DOWN STREAM RESTRICTIONS INCREASE IN ANY MANNER, THE INJECTOR WILL STOP DRAWING FLUID IF IT IS INCONVIENT TO REMOVE THE RESTRICTION IMMEDIATELY, THE INJECTOR MAY BE PUT BACK INTO OPERATION BY TURNING THE WATER BYPASS SCREW CLOCKWISE; THIS ADJUST THE INJECTOR TO A LOWER FLOW RATE. THE BYPASS SCREW SHOULD BE RESET ONCE THE RESTRICTION IS REMOVED.

CAUTION: WHEN SERVICING UNIT BE SURE THAT REPLACEMENT PARTS HAVE BEEN INSTALLED ACCORDING TO DRAWING. BE CERTAIN CHECK VALVE PARTS ARE IN PLACE

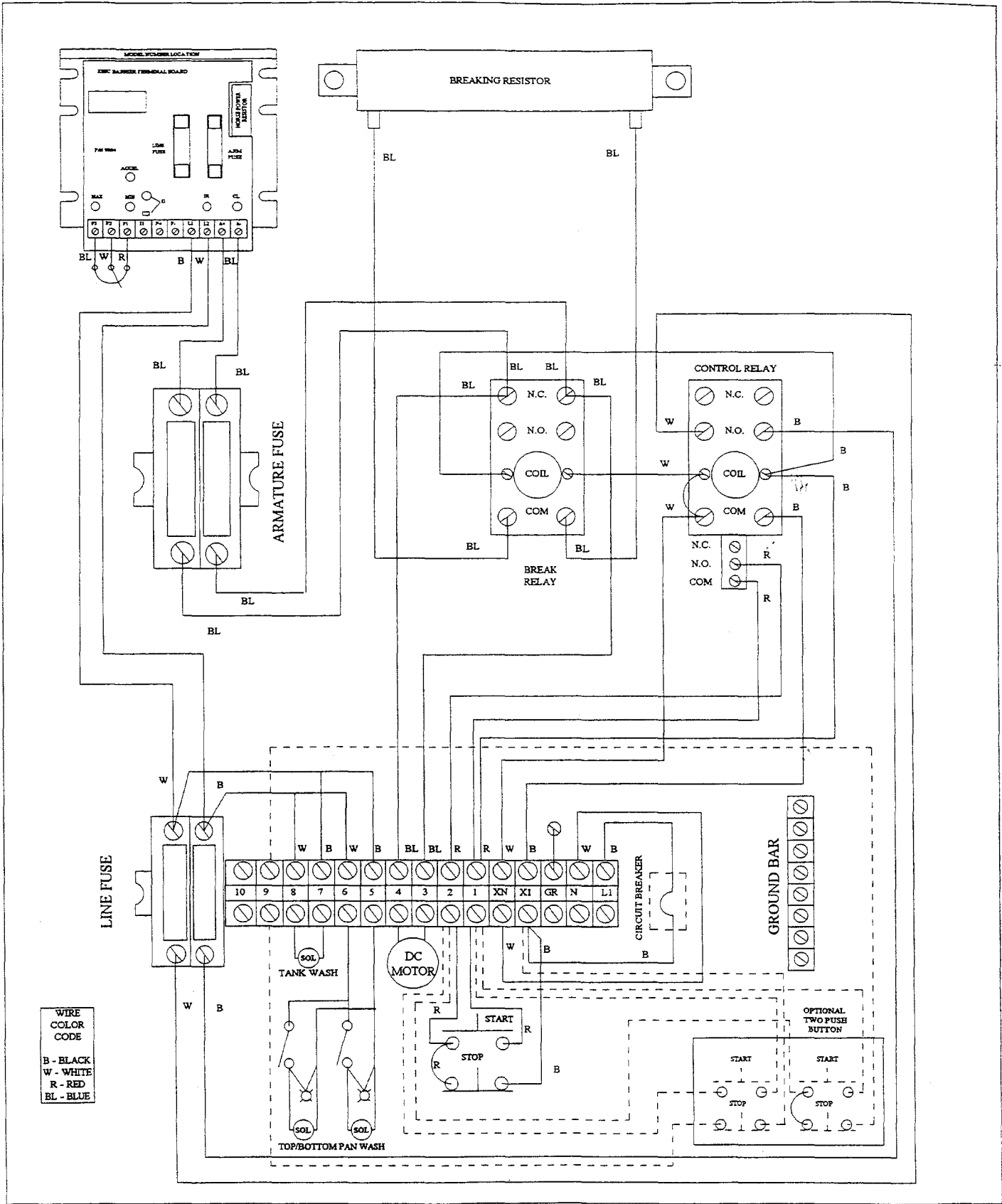

LOW TEMP INDUSTRIES INC.
 JONESBORO, GEORGIA

CONVEYOR WIRING DIAGRAM
 BASIC SYSTEM / NO LIMIT SWITCH

DIAGRAM NO.
 LTCONWD-001

DATE: 7-18-96

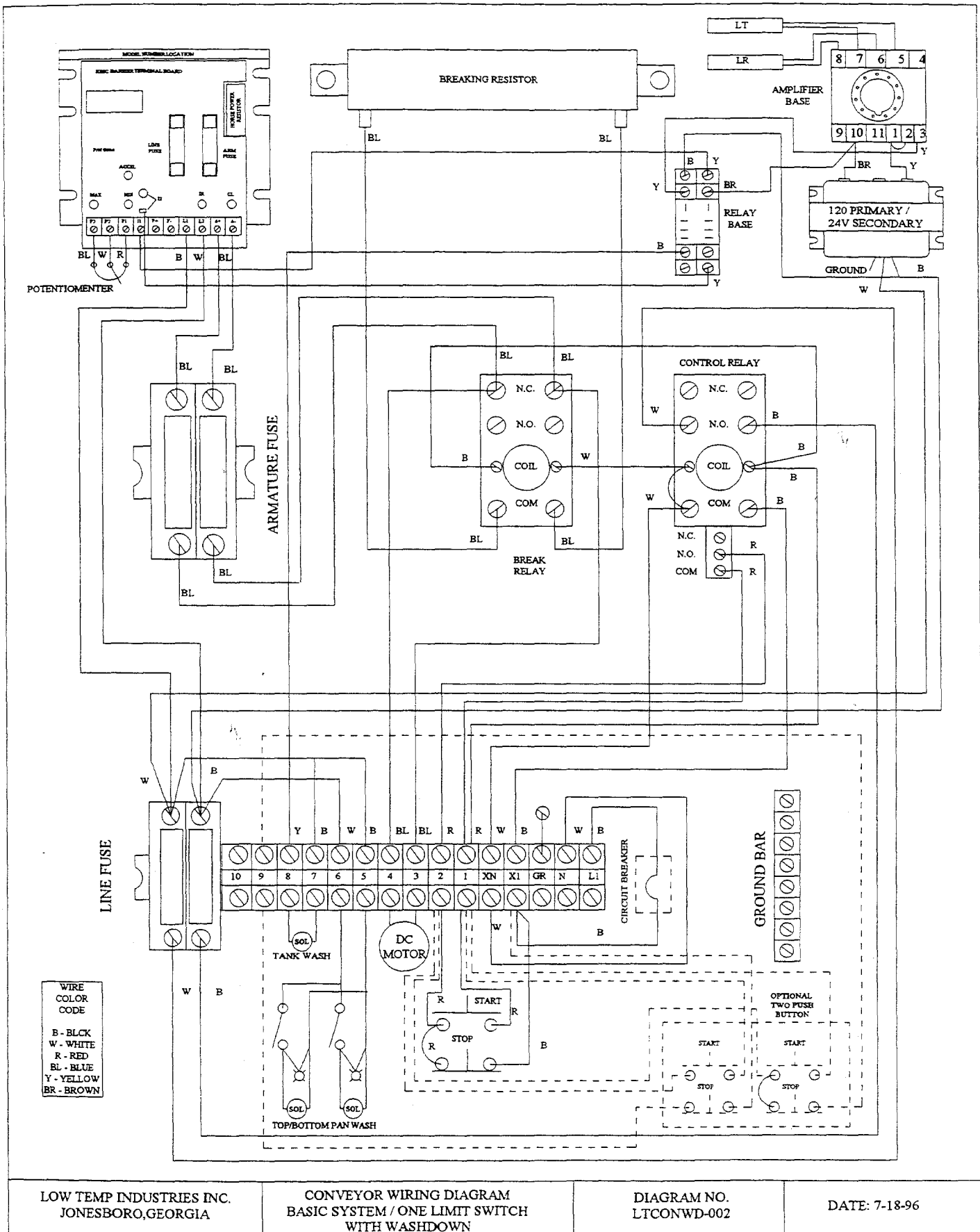

LOW TEMP INDUSTRIES INC.
JONESBORO, GEORGIA

CONVEYOR WIRING DIAGRAM
BASIC SYSTEM / ONE LIMIT SWITCH
WITH WASHDOWN

DIAGRAM NO.
LTCONWD-002

DATE: 7-18-96

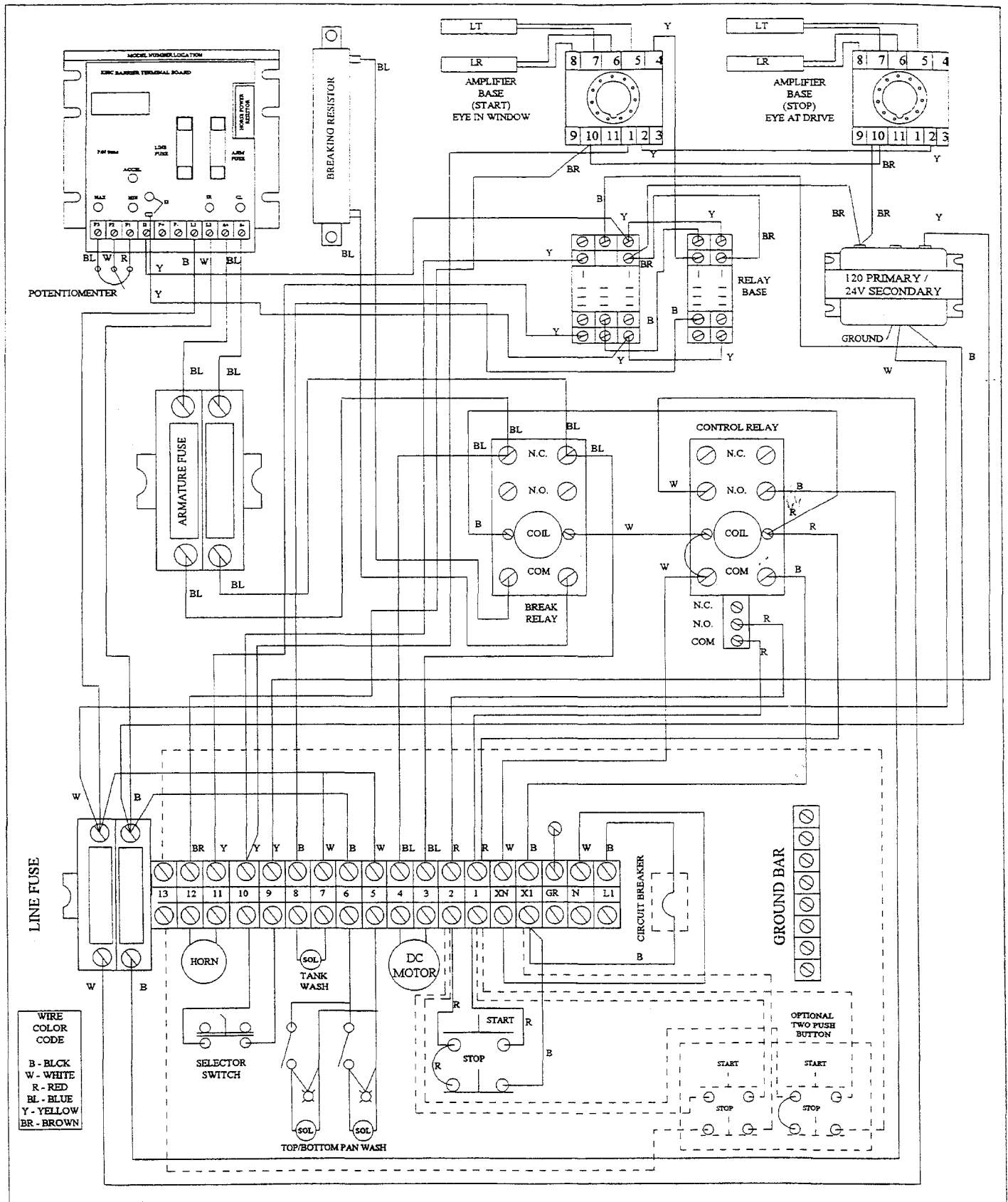

LOW TEMP INDUSTRIES INC.
JONESBORO, GEORGIA

CONVEYOR WIRING DIAGRAM
AUTOMATIC SYSTEM / TWO LIMIT SWITCH
WITH WASHDOWN

DIAGRAM NO.
LTCONWD-003

DATE: 7-19-96

CD & CB SERIES CONVEYOR PARTS LIST 1/2 H.P. SYSTEM

NOTE! CHECK NAME PLATE FOR VOLTAGE AND H.P. OF YOUR UNIT

ITEM NO.	PART NAME	STOCK NO.	MFG. NAME & PART NO.
ELECTRICAL CONTROLS			
1	1/2 H.P.D.C. CONTROL BOARD	514600	KBIC-120 (FOR 1/2H.P.)
2	1/2 H.P. RESISTOR	514610	9814 (.025 OHM)
3	TERMINAL BARRIER BOARD	514620	9844 KBIC TERMINAL
4	BOARD ARMATURE FUSE 6 AMP	514750	ABC 6 (6 AMP)
4A	BOARD LINE FUSE 8 AMP	514720	ABC 8 (8 AMP)
5	BREAKING RESISTOR	514740	9865 (10 OHM/70WATT)
6	TERMINAL STRIP	513700	BUCHANAN 724
6A	TERMINAL END SECTION	513730	BUCHANAN 730
7	LINE FUSE BLOCK	513900	BUCHANAN 362
7A	LINE FUSE BLOCK END	514000	BUCHANAN 330
8	LINE FUSE	513910	TRM-8 (8 AMP)
9	ARMATURE FUSE BLOCK	514020	LITTLE LH25030-2C
10	ARMATURE FUSE	513892	TR6R (6 AMP)
11	CONTROL RELAY	514100	DELTROL 900DPDT-1C
12	BREAKING RELAY	514200	DELTROL 900 DPDT
13	CIRCUIT BREAKER 15 A	515110	ETA 45-700-1G1-P10-DD
13A	BOOT FOR CIRCUIT BREAKER	515120	ETA N.1.480.08
14	SPEED POTENTIOMETER	518300	A/B 800H-UR24
14A	SPEED POT. LEGEND PLATE	518310	A/B 800H-W080
15	START PUSH BUTTON	517310	A/B 800H-AR1D1
15A	START LEGEND PLATE	517360	A/B 800H-W126
16	STOP PUSH BUTTON	517320	A/B 800H-BR6D2
16A	STOP LEGEND PLATE	517330	A/B 800H-W371
17	SELECTOR SWITCH	517200	C/H 10250T1311
17A	SELECTOR SWITCH CONTACT BLOCK	517100	C/H 10250T1
17B	SELECTOR SWITCH LEGEND PLATE	517300	C/H 10250TS67
18	TOGGLE SWITCH	335900	McGILL 0090-0001
19	PILOT LIGHT	335800	JEMCO 515-5CL
PHOTOEYE COMPONENTS & CONTROLS			
20	CONTROL TRANSFORMER	514430	EDWARDS #592
21	PHOTO ELEC. SOCKET BASE	515360	IDEC SR3P-06
22	PHOTO ELEC. AMPLIFIER 24V	515350	TELCO PA-11A-302
23	SLIM LINE RECIEVER	515310	TELCO LR-SG-15M
23A	SLIM LINE TRANSMITTER	515320	TELCO LT-SG-15M
24	COMPACT RECIEVER	515330	TELCO LR-WS-15M
24A	COMPACT TRANSMITTER	515340	TELCO LT-WS-15M
25	FOOT SWITCH	513650	NAUTILUS WP-541-S
26	RELAY BASE DOUBLE POLE	515820	IDEC SH2B05
26A	RELAY DOUBLE POLE 24VAC	515830	IDEC RH2BUAC24V
27	RELAY BASE THREE POLE	515800	IDEC SH3B05
27A	REALAY THREE POLE 24VAC	515810	IDEC RH3BUAC24V
28	ADAPTOR BUZZER	515900	EDWARDS 340A-G5

**CD & CB SERIES CONVEYOR
PARTS LIST
1/2 H.P. SYSTEM
(CONT.)**

ITEM NO.	PART NAME	STOCK	MFG. NAME. & PART NO.
PLUMBING COMPONENTS			
29	DETERGENT INJECTOR	514510	DEMA 202B
30	MIXING VALVE	519800	WATTS #70-AT-1/2"
31	SOLENOID VALVE	502800	ASCO 8210D1-2NC
32	VACUME BRAEKER	519900	WATTS 288A
35	"Y" STARAINER (CPVC)	522000	HAYWARD YS20050S
34	TRUE UNION BALL VALVE (CPVC)	527100	CHEMTROL U51TB-E
35	TANK SPRAY HEAD	479120	SPRAY SYS. 1/4QTT+6505
36	PAN WASH NOZZLE INLET	240000	CMPNT. HDWE. K36-6000
DRIVE COMPONENTS			
37	1/2 H.P. MOTOR	513250	IG 4660-535-1143,XX
38	1/2 H.P. GEAR BOX	513210	HUB CITY 214
39	GEAR OIL	513270	MOBIL SHC-634
40	1/2 H.P. CLUTCH 7/8" BORE	518410	OSD-337
40A	1/2 H.P. CLUTCH SPROCKET	518420	50A-21G
41	TOP DRIVE SPROCKET	519000	#50, 19 TOOTH 1-3/16" BORE
42	SNAP IDLER (CHAIN TENSIONER)	519130	#50 SNAP IDLER
43	PILLOW BLOCK BEARING 1-3/16" BORE	519500	(AM) BLL6-19
44	FLANGE BEARING 1-3/16" BORE	519510	(AM) BFX 206-
45	3873 SLAT CHAIN SPROCKET (PLASTIC) 1-3/16" BORE	519330	REX. N614-27-2
45A	3873 SLAT CHAIN SPROCKET (STAINLESS STEEL) 1-3/16" BORE	519400	S/S #60 25TOOTH 1-3/16" BORE, 1/4 X 1/8" KEY
46	821 BELT DRIVE SPROCKET (PLASTIC) 1-3/16" BORE	518600	REX. N821-25T
47	3873 SIDE FLEX SLAT/CHAIN COMBO (SOLD IN 10 FT LENGTH)	517600	REX. D3873SSK10
48	3873 SIDE FLEX SLAT ONLY	519610	REX. 114-129-3
49	821 STRAIGHT RUN BELT (SOLD IN 10 FT LENGTH)	519611	REX. D821-K10
50	1/2" FULL ROUND UHMW (8' LENGTH) (USED WITH 3873 SIDE FLEX SYSTEM)	310710	NOLU HSS-0811-240
51	GUIDE RAIL/FLAT TOP UHMW/SS (USED WITH 821 STRAIGHT SYSTEM)	310800	NOLU DGR-7012-120
52	#50 ROLLER CHAIN 5/8" PITCH	518800	MORSE #50 RIV
53	#50 MASTER LINK	518820	5/8" PITCH #50
54	#50 HALF LINK	518830	5/8" PITCH #50
55	#60 MASTER LINK S.S.	519630	REX. 63SSCL
56	DRIVE SHAFT 1-3/16" DIA. 18-1/2" S.S.	519410	1-3/16" DIA 1/4 X 1/8 KEY
57	TAIL SHAFT 1-3/16" DIA. 15-1/2" S.S.	519420	1-3/16" DIA 1/4 X 1/8 KEY
58	SPLASH GUARD TOP 3873 STYLE	519430	RUBBER 12 X 3 W/ NOTCH
59	SPLASH GUARD TOP 3873 STYLE	519431	RUBBER 12 X 3 STRAIGHT
60	SPLASH GUARD BOTTOM	519432	RUBBER 12 X 2 STRAIGHT
61	SPLASH GUARD HOLDING STRAP	519433	14 GA. S.S. 12 X 1
62	DRIVE GEAR GUARD	519434	UHMW 12-3/4" X 10 W/ CUT-OUT
63	GUIDE ROLLER	519435	1.9" DIA X 12" LONG SPG. SHAFT
64	SHAFT SEAL	519436	RUBBER 4" X 4" W/ SHAFT HOLE

CD & CB SERIES CONVEYOR PARTS LIST 3/4 H.P. SYSTEM

NOTE! CHECK NAME PLATE FOR VOLTAGE AND H.P. OF YOUR UNIT

ITEM NO.	PART NAME	STOCK NO.	MFG. NAME & PART NO.
ELECTRICAL CONTROLS			
1	3/4 H.P.D.C. CONTROL BOARD	514700	KBIC-125 (FOR 3/4 H.P.)
2	3/4 H.P. RESISTOR	514710	9842 (.015 OHM)
3	TERMINAL BARRIER BOARD	514620	9844 KBIC TERMINAL
4	BOARD ARMATURE FUSE 8 AMP	514720	ABC 8 (8 AMP)
4A	BOARD LINE FUSE 12 AMP	514730	ABC 12 (12 AMP)
5	BREAKING RESISTOR	514740	9865 (10 OHM/70WATT)
6	TERMINAL STRIP	513700	BUCHANAN 724
6A	TERMINAL END SECTION	513730	BUCHANAN 730
7	LINE FUSE BLOCK	513900	BUCHANAN 362
7A	LINE FUSE BLOCK END	514000	BUCHANAN 330
8	LINE FUSE	513930	TRM-12 (12 AMP)
9	ARMATURE FUSE BLOCK	514020	LITTLE LH25030-2C
10	ARMATURE FUSE	513894	TR8R (8 AMP)
11	CONTROL RELAY	514100	DELTRON 900DPDT-1C
12	BREAKING RELAY	514200	DELTRON 900 DPDT
13	CIRCUIT BREAKER 15 A	515110	ETA 45-700-1G1-P10-DD
13A	BOOT FOR CIRCUIT BREAKER	515120	ETA N.1.480.08
14	SPEED POTENTIOMETER	518300	A/B 800H-UR24
14A	SPEED POT. LEGEND PLATE	518310	A/B 800H-W080
15	START-PUSH BUTTON	517310	A/B 800H-AR1D1
15A	START LEGEND PLATE	517360	A/B 800H-W126
16	STOP PUSH BUTTON	517320	A/B 800H-BR6D2
16A	STOP LEGEND PLATE	517330	A/B 800H-W371
17	SELECTOR SWITCH	517200	C/H 10250T1311
17A	SELECTOR SWITCH CONTACT BLOCK	517100	C/H 10250T1
17B	SELECTOR SWITCH LEGEND PLATE	517300	C/H 10250TS67
18	TOGGLE SWITCH	335900	McGILL 0090-0001
19	PILOT LIGHT	335800	JEMCO 515-5CL

PHOTOEYE COMPONENTS & CONTROLS

20	CONTROL TRANSFORMER	514430	EDWARDS #592
21	PHOTO ELEC. SOCKET BASE	515360	IDEC SR3P-06
22	PHOTO ELEC. AMPLIFIER 24V	515350	TELCO PA-11A-302
23	SLIM LINE RECEIVER	515310	TELCO LR-SG-15M
23A	SLIM LINE TRANSMITTER	515320	TELCO LT-SG-15M
24	COMPACT RECEIVER	515330	TELCO LR-WS-15M
24A	COMPACT TRANSMITTER	515340	TELCO LT-WS-15M
25	FOOT SWITCH	513650	NAUTILUS WP-541-S
26	RELAY BASE DOUBLE POLE	515820	IDEC SH2B05
26A	RELAY DOUBLE POLE 24VAC	515830	IDEC RH2BUAC24V
27	RELAY BASE THREE POLE	515800	IDEC SH3B05
27A	RELAY THREE POLE 24VAC	515810	IDEC RH3BUAC24V
28	ADAPTOR BUZZER	515900	EDWARDS 340A-G5

**CD & CB SERIES CONVEYOR
PARTS LIST
3/4 H.P. SYSTEM
(CONT.)**

ITEM NO.	PART NAME	STOCK	MFG. NAME. & PART NO.
PLUMBING COMPONENTS			
29	DETERGENT INJECTOR	514510	DEMA 202B
30	MIXING VALVE	519800	WATTS #70-AT-1/2"
31	SOLENOID VALVE	502800	ASCO 8210D1-2NC
32	VACUME BRAEAKER	519900	WATTS 288A
33	"Y" STARAINER (CPVC)	522000	HAYWARD YS20050S
34	TRUE UNION BALL VALVE (CPVC)	527100	CHEMTROL U51TB-E
35	TANK SPRAY HEAD	479120	SPRAY SYS. 1/4QTT+6505
36	PAN WASH NOZZLE INLET	240000	CMPNT. HDWE. K36-6000
DRIVE COMPONENTS			
37	3/4 H.P. MOTOR	513230	IG 4660-635-2143;XX
38	3/4 H.P. GEAR BOX	513292	HUB CITY 264
39	GEAR OIL	513270	MOBIL SHC-634
40	3/4 H.P. CLUTCH 1-1/4" BORE	518450	OSD-450
40A	3/4 H.P. CLUTCH SPROCKET	518460	50A-26G
41	TOP DRIVE SPROCKET	519000	#50, 19 TOOTH 1-3/16" BORE
42	SNAP IDLER (CHAIN TENSIONER)	519130	#50 SNAP IDLER
43	PILLOW BLOCK BEARING 1-3/16" BORE	519500	(AMI) BLL6-19
44	FLANBE BEARING 1-3/16" BORE	519510	(AMI) BFX 206-19
45	3873 SLAT CHAIN SPROCKET (PLASTIC) 1-3/16" BORE	519330	REX. N614-27-2
45A	3873 SLAT CHAIN SPROCKET (STAINLESS STEEL) 1-3/16" BORE	519400	S/S #60 25TOOTH 1-3/16" BORE, 1/4 X 1/8" KEY
46	821 BELT DRIVE SPROCKET (PLASTIC) 1-3/16" BORE	518600	REX. N821-25T
47	3873 SIDE FLEX SLAT/CHAIN COMBO (SOLD IN 10 FT LENGTH)	517600	REX. D3873SSK10
48	3873 SIDE FLEX SLAT ONLY	519610	REX. 114-129-3
49	821 STRAIGHT RUN BELT (SOLD IN 10 FT LENGTH)	519611	REX. D821-K10
50	1/2" FULL ROUND UHMW (8' LENGTH) (USED WITH 3873 SIDE FLEX SYSTEM)	310710	NOLU HSS-0811-240
51	GUIDE RAIL/FLAT TOP UHMW/SS (USED WITH 821 STRAIGHT SYSTEM)	310800	NOLU DGR-7012-120
52	#50 ROLLER CHAIN 5/8" PITCH	518800	MORSE #50 RIV
53	#50 MASTER LINK	518820	5/8" PITCH #50
54	#50 HALF LINK	518830	5/8" PITCH #50
55	#60 MASTER LINK S.S.	519630	REX. 63SSCL
56	DRIVE SHAFT 1-3/16" DIA. 18-1/2" S.S.	519410	1-3/16" DIA 1/4 X 1/8 KEY
57	TAIL SHAFT 1-3/16" DIA. 15-1/2" S.S.	519420	1-3/16" DIA 1/4 X 1/8 KEY
58	SPLASH GUARD TOP 3873 STYLE	519430	RUBBER 12 X 3 W/ NOTCH
59	SPLASH GUARD TOP 3873 STYLE	519431	RUBBER 12 X 3 STRAIGHT
60	SPLASH GUARD BOTTOM	519432	RUBBER 12 X 2 STRAIGHT
61	SPLASH GUARD HOLDING STRAP	519433	14 GA. S.S. 12 X 1
62	DRIVE GEAR GUARD	519434	UHMW 12-3/4" X 10 W/ CUT-OUT
63	GUIDE ROLLER	519435	1.9" DIA X 12" LONG SPG. SHAFT
64	SHAFT SEAL	519436	RUBBER 4" X 4" W/ SHAFT HOLE

CD & CB SERIES CONVEYOR PARTS LIST 1 H.P. SYSTEM

NOTE: CHECK NAME PLATE FOR VOLTAGE AND H.P. OF YOUR UNIT

ITEM NO.	PART NAME	STOCK NO.	MFG. NAME & PART NO.
ELECTRICAL CONTROLS			
1	D.C. CONTROL BOARD (USED WITH 9867 HEAT SINK ON 1 H.P. DC SYSTEM)	514600	KBIC-120 (FOR 1 H.P.)
1A	AUXILIARY HEAT SINK (USED WITH KBIC-120 ON 1 H.P. DC SYSTEM)	514820	9867 (FOR 1 H.P.)
2	1 H.P. RESISTOR	514810	9843 (.01 OHM)
3	TERMINAL BARRIER BOARD	514620	9844 KBIC TERMINAL
4	BOARD ARMATURE FUSE 12 AMP	514730	ABC 12 (12 AMP)
4A	BOARD LINE FUSE 15 AMP	514780	ABC 15 (15 AMP)
5	BREAKING RESISTOR	514740	9865 (10 OHM/70WATT)
6	TERMINAL STRIP	513700	BUCHANAN 724
6A	TERMINAL END SECTION	513730	BUCHANAN 730
7	LINE FUSE BLOCK	513900	BUCHANAN 362
7A	LINE FUSE BLOCK END	514000	BUCHANAN 330
8	LINE FUSE	513920	TRM-15 (15 AMP)
9	ARMATURE FUSE BLOCK	514020	LITTLE LH25030-2C
10	ARMATURE FUSE	513896	TR10R (10 AMP)
11	CONTROL RELAY	514100	DELTROL 900DPDT-1C
12	BREAKING RELAY	514200	DELTROL 900 DPDT
13	CIRCUIT BREAKER 15 A	515110	ETA 45-700-1G1-P10-DD
13A	BOOT FOR CIRCUIT BREAKER	515120	ETA N.1.480.08
14	SPEED POTENTIOMETER	518300	A/B 800H-UR24
14A	SPEED POT. LEGEND PLATE	518310	A/B 800H-W080
15	START PUSH BUTTON	517310	A/B 800H-AR1D1
15A	START LEGEND PLATE	517360	A/B 800H-W126
16	STOP PUSH BUTTON	517320	A/B 800H-BR6D2
16A	STOP LEGEND PLATE	517330	A/B 800H-W371
17	SELECTOR SWITCH	517200	C/H 10250T1311
17A	SELECTOR SWITCH CONTACT BLOCK	517100	C/H 10250T1
17B	SELECTOR SWITCH LEGEND PLATE	517300	C/H 10250TS67
18	TOGGLE SWITCH	335900	McGILL 0090-0001
19	PILOT LIGHT	335800	JEMCO 515-5CL

PHOTOEYE COMPONENTS & CONTROLS

20	CONTROL TRANSFORMER	514430	EDWARDS #592
21	PHOTO ELEC. SOCKET BASE	515360	IDEC SR3P-06
22	PHOTO ELEC. AMPLIFIER 24V	515350	TELCO PA-11A-302
23	SLIM LINE RECIEVER	515310	TELCO LR-SG-15M
23A	SLIM LINE TRANSMITTER	515320	TELCO LT-SG-15M
24	COMPACT RECIEVER	515330	TELCO LR-WS-15M
24A	COMPACT TRANSMITTER	515340	TELCO LT-WS-15M
25	FOOT SWITCH	513650	NAUTILUS WP-541-S
26	RELAY BASE DOUBLE POLE	515820	IDEC SH2B05
26A	RELAY DOUBLE POLE 24VAC	515830	IDEC RH2BUAC24V
27	RELAY BASE THREE POLE	515800	IDEC SH3B05
27A	REALAY THREE POLE 24VAC	515810	IDEC RH3BUAC24V
28	ADAPTOR BUZZER	515900	EDWARDS 340A-G5

**CD & CB SERIES CONVEYOR
PARTS LIST
1 H.P.
(CONT.)**

ITEM NO.	PART NAME	STOCK	MFG. NAME. & PART NO.
PLUMBING COMPONENTS			
29	DETERGENT INJECTOR	514510	DEMA 202B
30	MIXING VALVE	519800	WATTS #70-AT-1/2"
31	SOLENOID VALVE	502800	ASCO 8210D1-2NC
32	VACUME BRAEAKER	519900	WATTS 288A
33	"Y" STARAINER (CPVC)	522000	HAYWARD YS20050S
34	TRUE UNION BALL VALVE (CPVC)	527100	CHEMTROL U51TB-E
35	TANK SPRAY HEAD	479120	SPRAY SYS. 1/4QTT+6505
36	PAN WASH NOZZLE INLET	240000	CMPNT. HDWE. K36-6000
DRIVE COMPONENTS			
37	1 H.P. MOTOR	518480	IG 4680-735-2143-XX
38	1 H.P. GEAR BOX	513293	HUB CITY 324
39	GEAR OIL	513270	MOBIL SHC-634
40	1 H.P. CLUTCH 1-3/8" BORE	518480	OSD-450D
40A	1 H.P. CLUTCH SPROCKET	518460	50A-26G
41	TOP DRIVE SPROCKET	519000	#50, 19 TOOTH 1-3/16" BORE
42	SNAP IDLER (CHAIN TENSIONER)	519130	#50 SNAP IDLER
43	PILLOW BLOCK BEARING 1-3/16" BORE	519500	(AMI) BLL6-19
44	FLANBE BEARING 1-3/16" BORE	519510	(AMI) BFX 206-19
45	3873 SLAT CHAIN SPROCKET (PLASTIC) 1-3/16" BORE	519330	REX. N614-27-2
45A	3873 SLAT CHAIN SPROCKET (STAINLESS STEEL) 1-3/16" BORE	519400	S/S #60 25TOOTH 1-3/16" BORE, 1/4 X 1/8" KEY
46	821 BELT DRIVE SPROCKET (PLASTIC) 1-3/16" BORE	518600	REX. N821-25T
47	3873 SIDE FLEX SLAT/CHAIN COMBO (SOLD IN 10 FT LENGTH)	517600	REX. D3873SSK10
48	3873 SIDE FLEX SLAT ONLY	519610	REX. 114-129-3
49	821 STRAIGHT RUN BELT (SOLD IN 10 FT LENGTH)	519611	REX. D821-K10
50	1/2" FULL ROUND UHMW (8' LENGTH) (USED WITH 3873 SIDE FLEX SYSTEM)	310710	NOLU HSS-0811-240
51	GUIDE RAIL/FLAT TOP UHMW/SS) (USED WITH 821 STRAIGHT SYSTEM)	310800	NOLU DGR-7012-120
52	#50 ROLLER CHAIN 5/8" PITCH	518800	MORSE #50 RIV
53	#50 MASTER LINK	518820	5/8" PITCH #50
54	#50 HALF LINK	518830	5/8" PITCH #50
55	#60 MASTER LINK S.S.	519630	REX. 63SSCL
56	DRIVE SHAFT 1-3/16" DIA. 18-1/2" S.S.	519410	1-3/16" DIA 1/4 X 1/8 KEY
57	TAIL SHAFT 1-3/16" DIA. 15-1/2" S.S.	519420	1-3/16" DIA 1/4 X 1/8 KEY
58	SPLASH GUARD TOP 3873 STYLE	519430	RUBBER 12 X 3 W/ NOTCH
59	SPLASH GUARD TOP 3873 STYLE	519431	RUBBER 12 X 3 STRAIGHT
60	SPLASH GUARD BOTTOM	519432	RUBBER 12 X 2 STRAIGHT
61	SPLASH GUARD HOLDING STRAP	519433	14 GA. S.S. 12 X 1
62	DRIVE GEAR GUARD	519434	UHMW 12-3/4" X 10 W/ CUT-OUT
63	GUIDE ROLLER	519435	1.9" DIA X 12" LONG SPG. SHAFT
64	SHAFT SEAL	519436	RUBBER 4" X 4" W/ SHAFT HOLE

TROUBLE SHOOTING (ELECTRICAL)

SYMPTOM	POSSIBLE PROBLEM	SOLUTION
CONVEYOR WILL NOT START		
START BUTTON DEPRESSED NOTHING HAPPENS	1. OPEN LINE VOLTAGE SUPPLYING SYSTEM CHECK LINE VOLTAGE AT TERMINAL L1 AND N	1. CHECK MAIN BREAKER FEEDING SYSTEM.
	2. OPEN CIRCUIT BREAKER ON SYSTEM	2. CHECK CIRCUIT BREAKER LOCATED IN CONTROL PANEL. RESET IF TRIPPED.
START BUTTON DEPRESSED CONTROL RELAY & BREAKING RELAY ACTIVATE	1. CHECK LINE VOLTAGE ON CONTROL RELAY AT COM AND N.O.	1. IF VOLTAGE AT COM BUT NOT AT N.O. RELAY IS BAD, REPLACE
	2. CHECK VOLTAGE AT FUSE BLOCK AT TOP OF TERMINAL STRIP.	2. IF FUSES BLOWN REPLACE
	3. CHECK LINE VOLTAGE AT TERMINALS L1 & L2 ON KBIC BOARD.	3. IF NO VOLTAGE FUSE AT END OF TERMINAL STRIP IS BLOWN.
	4. CHECK LINE FUSE & ARMATURE FUSE ON KBIC BOARD	4. IF BLOWN REPLACE
	5. CHECK OUT VOLTAGE AT TERMINALS A+ AND A- ON KBIC BOARD	5. IF INHIBIT (ARMATURE SWITCHING CIRCUIT) IS USED REMOVE JUMPER FROM "I2" TO REMOVE INHIBIT CIRCUIT BEFORE PROCEEDING. IF NO DC VOLTAGE IS SEEN REMOVE WIRE LEADS FROM A+ AND A- TO ISOLATE BOARD ADJUST SPEED POT. TO FULL CLOCKWISE POSITION. IF NO VOLTAGE PRESENT REPLACE BOARD.
	6. CHECK ARMATURE FUSES BETWEEN THE CONTROL BOARD AND MOTOR	6. IF FUSE IS BLOWN REPLACE.

NOTE! ALSO INSPECT THE ARMATURE BRUSHES ON THE DC MOTOR BEFORE REPLACING WITH A NEW CONTROL BOARD. ARMATURE BRUSHES WORN DOWN TO THE CASING SHORTED TO THE ARMATURE CAN CAUSE PROBLEMS WITH CONTROL BOARD.

**TROUBLE SHOOTING
(ELECTRICAL)
(CONT.)**

SYMPTOM	POSSIBLE PROBLEM	SOLUTION
CONVEYOR WILL NOT START (CONT).		
SYSTEM WILL NOT RUN WITH INHIBIT CIRCUIT WIRED IN BUT WILL RUN WITH "I2" JUMPER REMOVED.	1. AMPLIFIER SET TO LIGHT POSITION 2. PHOTO EYE IS BLOCKED 3. PHOTO EYE IS OUT OF ALIGNMENT 4. GAIN SET TOO LOW 5. DEFECTIVE PHOTO EYE OR AMPLIFIER	1. SWITCH TO DARK 2. REMOVE OBJECT FROM BEAM PATH 3. CHECK ALIGNMENT INDICATOR ON AMPLIFIER 4. ADJUST GAIN ON AMPLIFIER 5. REPLACE
CONVEYOR WILL NOT STOP		
STOP BUTTON IS DEPRESSED AND HAS NO EFFECT.	1. CHECK CONTACTS ON STOP BUTTON 2. PHOTO EYE OR AMPLIFIER DEFECTIVE	1. IF DEFECTIVE REPLACE 2. REPLACE
CONVEYOR RUNS FOR A SHORT TIME AND STOPS		
INHIBIT CIRCUIT REMOVED FROM	1. CURRENT LIMIT OUT OF ADJUSTMENT ON KBIC BOARD. 2. MOTOR BRUSHES WORN AND CAUSING SHORT TO CONTROL BOARD	1. SEE THE SECTION ON SYSTEM CONVEYOR CONTROL BOARD AND ADJUST "CL" AS SHOWN. 2. REPLACE BRUSHES
INHIBIT CIRCUIT IN SYSTEM	1. PHOTO EYE IS BLOCKED OR MISALIGNED AND TIME ON SETTING IS IN USE	1. CLEAR PHOTO EYE
BELT JUMPING (COGGING)		
SYSTEM RUNS SMOOTH THEN STARTS TO JUMP	1. "IR" COMP. OUT OF ADJUSTMENT	1. SEE SECTION ON CONTROL BOARD FOR ADJUSTMENT

TROUBLE SHOOTING (MECHANICAL)

SYMPTOM	POSSIBLE PROBLEM	SOLUTION
NOISY SYSTEM		
BELT IS TRAVELING SMOOTHLY BUT POPS	1. SPROCKET HAS SHIFTED ON DRIVE SHAFT	1. CENTER SPROCKET ON SHAFT
	2. TAIL SECTION TENSION ADJUSTMENT BRACKET NOT STRAIGHT	2. REALIGN TAIL SECTION ADJUSTMENT BRACKET
	3. CHECK CANTINARY SAG OF BELT	3. ADJUST BELT TENSION
DRIVE SHAFT NOISY	1. BEARING NEEDS GREASING	1. GREASE BEARING
DRIVE CHAIN POPPING	1. CHAIN TENSION LOOSE	1. READJUST SNAP IDLER
	2. CHAIN NEEDS LUBING	2. LUBRICATE CHAIN
	3. CHAIN WORN OUT	3. REPLACE CHAIN
GEAR BOX NOISY	1. LOW OIL LEVEL IN GEAR BOX	1. FILL AS REQUIRED
MOTOR NOISY	1. WORN BEARINGS	1. REPLACE BEARINGS OR MOTOR

NOTE! IF THE SYSTEM BECOMES JABBED IT CAN BE REVERSED BY SWAPPING THE A+ AND A- TERMINALS ON THE "KBIC" BOARD.

BROKEN SLAT ON CONVEYOR BELT

SIDE FLEX 3873 SYSTEM

TO REPLACE A BROKEN SLAT REFER TO THE DRAWING PROVIDED IN THIS MANUAL FOR THIS SYSTEM. THE SLAT SNAPS OVER THE SIDE PINS PROVIDED ON THE STAINLESS STEEL BASE CHAIN.

TO REMOVE SLAT

TAKE A SCREWDRIVER OR SOME TYPE OF PRYING TOOL AND WEDGE IT BETWEEN THE BOTTOM OF THE "TEE" BASE AND THE CHAIN.

TO INSTALL NEW SLAT

MOVE THE CONVEYOR CHAIN UNTIL THE OPEN SLAT AREA IS DIRECTLY OVER THE DRIVE SPROCKET. USE THE SPROCKET AS A BACK STOP TO SUPPORT THE CHAIN. PLACE THE SLAT OVER THE CHAIN GUIDE PINS AND DRIVE OVER THE PINS USING A HAMMER. BE SURE TO STRIKE THE SLAT IN THE MIDDLE DIRECTLY OVER THE CHAIN.

STRAIGHT RUN 821 SYSTEM

TO REPLACE A BROKEN SLAT REFER TO THE DRAWING PROVIDED IN THIS MANUAL FOR THIS SYSTEM. EACH SLAT HAS A HINGE PIN AT EACH SLAT. NOTE THAT ONE HINGE OPENING IS LARGER THAN THE OTHER. THE HINGE PIN HAS A KNURLED END AND CAN BE DRIVEN IN ONE DIRECTION ONLY.

TROUBLE SHOOTING (PLUMBING)

SYMPTOM	POSSIBLE PROBLEM	SOLUTION
WATER WILL NOT START		
CONVEYOR IS RUNNING BUT TANK WASH SPRAY IS NOT SUPPLY FEEDING THE SYSTEM WORKING	1. WATER SUPPLY IS OFF	1. CHECK MAIN WATER
	2. BALL VALVE IS CLOSED ON CONVEYOR SYSTEM	2. CHECK BALL VALVE ON CONVEYOR FEEDING THE TANK.
	3. SOLENOID NOT OPEN	3. CHECK POWER FEEDING SOLENOID FROM CONTROL PANEL.
	4. SOLENOID CLOGGED OR DEFECTIVE	4. REMOVE SOLENOID AND INSPECT FOR DEBRIS. REPLACE IF NECESSARY
PAN WASH SWITCHES ARE ON BUT NO WATER TO NOZZLES SUPPLY FEEDING THE SYSTEM	1. WATER SUPPLY IS OFF	1. CHECK MAIN WATER
	2. BALL VALVE IS CLOSED ON CONVEYOR SYSTEM	2. CHECK BALL VALVE ON CONVEYOR FEEDING THE TANK.
	3. SOLENOID NOT OPEN	3. CHECK POWER FEEDING SOLENOID FROM CONTROL PANEL SWITCH.
	4. SOLENOID CLOGGED OR DEFECTIVE	4. REMOVE SOLENOID AND INSPECT FOR DEBRIS. REPLACE IF NECESSARY.
WATER WILL NOT STOP	1. SOLENOID COIL CLOSING	1. CHECK ELECTRICAL SIGNAL FROM CONTROL PANEL.
	2. SOLENOID CLOGGED OR DEFECTIVE	2. REMOVE SOLENOID AND INSPECT FOR DEBRIS. IF NECESSARY.

“DEMA” INJECTOR NOT DRAWING SEE THE SECTION IN THE MANUAL DETAILING THE FLUID OR DRAWING TOO MUCH OPERATION AND ADJUSTMENT OF THE “DEMA” INJECTOR.

WARRANTY

ALL LOW TEMP INDUSTRIES FOOD SERVICE EQUIPMENT IS FULLY WARRANTED BY THE MANUFACTURER AGAINST DEFECTS IN MATERIALS OR WORKMANSHIP FOR A PERIOD OF ONE (1) YEAR FROM THE DATE OF PURCHASE BY THE ORIGINAL USER AND ONLY TO THE ORIGINAL PURCHASER PROVIDED IT IS INSTALLED AND OPERATED IN ACCORDANCE WITH THE INSTRUCTIONS SUPPLIED WITH THE UNIT. ALSO, IT MUST NOT BE MISUSED, ALTERED OR NEGLECTED AND USED ONLY ON CIRCUITS AND VOLTAGES REQUIRED FOR THAT UNIT.

OUR OBLIGATION UNDER THIS WARRANTY SHALL BE LIMITED TO ONE OF THE FOLLOWING PROCEDURES. SELECTION OF A PROCEDURE SHALL BE AT THE SOLE DISCRETION OF LOW TEMP INDUSTRIES INC.

- A. REPLACEMENT OF DEFECTIVE PARTS, SHIPPED F.O.B. FACTORY, IN EXCHANGE FOR THE RETURNED DEFECTIVE PART, SHIPPED PREPAID FREIGHT.
- B. FREE REPLACEMENT OF DEFECTIVE PART, SHIPPED F.O.B. FACTORY.
- C. DEFECTIVE PART SHIPPED PREPAID FREIGHT TO FACTORY, REPAIRED AND RETURNED, SHIPPED F.O.B. . FACTORY.
- D. ALL **LABOR COSTS** SHALL BE COVERED FOR A PERIOD OF **90 DAYS** FROM THE DATE OF PURCHASE.

LOW TEMP INDUSTRIES INC. SHALL NOT BE RESPONSIBLE FOR ANY DAMAGE CAUSED BY FIRE, FLOOD, WINDSTORM, OR ANY OTHER ACT OF GOD; WAR, WHETHER DECLARED OR UNDECLARED NOR SHALL WE BE RESPONSIBLE FOR THE LOSS OF FOOD OR OTHER PRODUCTS DUE TO POWER OR MECHANICAL FAILURE. THIS WARRANTY SHALL NOT COVER ANY DAMAGE CAUSED DURING SHIPMENT WHICH SHOULD BE REPORTED TO THE DELIVERING CARRIER.

LOW TEMP MANUFACTURING COMPANY

A DIVISION OF LOW TEMP INDUSTRIES INC.

9192 TARA BOULEVARD

JONESBORO, GEORGIA 30236

(770) 478-8803