

**OPERATIONS AND MAINTENANCE MANUAL  
REPLACEMENT PARTS LIST  
FOR:**



# ATTENTION KITCHEN MANAGER

## IMPORTANT TECHNICAL NOTICE REFRIGERATION AIR FILTERS

All self contained refrigeration systems provided by Low Temp Industries are provided with a 10" x 10" x 1" air filter located at the face of the condenser directly behind the louver panel. It is important to check this filter every 30 days and replace if necessary to ensure the proper operation of the unit. Failure to check this filter and replace if clogged can and will cause premature compressor failure and will not be covered by factory warranty.

If construction is not complete when the equipment is started be sure that the filters are checked and replaced if necessary once the final clean up is completed.

The purpose for this filter is to keep the condenser fins as clean as possible. If the filter is removed and discarded the fins will become clogged and will require a chemical rinse to clear them. When the condenser fins become clogged or the filter is not checked and replaced the compressor work harder to maintain temperature and the box interior cabinet temperature will rise.

It is **very important** that the MAINTENANCE PERSONNEL be informed of this feature provided on our equipment. Your cooperation in maintaining this feature is greatly appreciated. If you have any questions or problems concerning this matter please contact Casey Hammonds or Ben Shackelford in the Low Temp Engineering Department 770-478-8803

## CONDENSER FILTER ACCESS CHANGE EVERY 30 DAYS

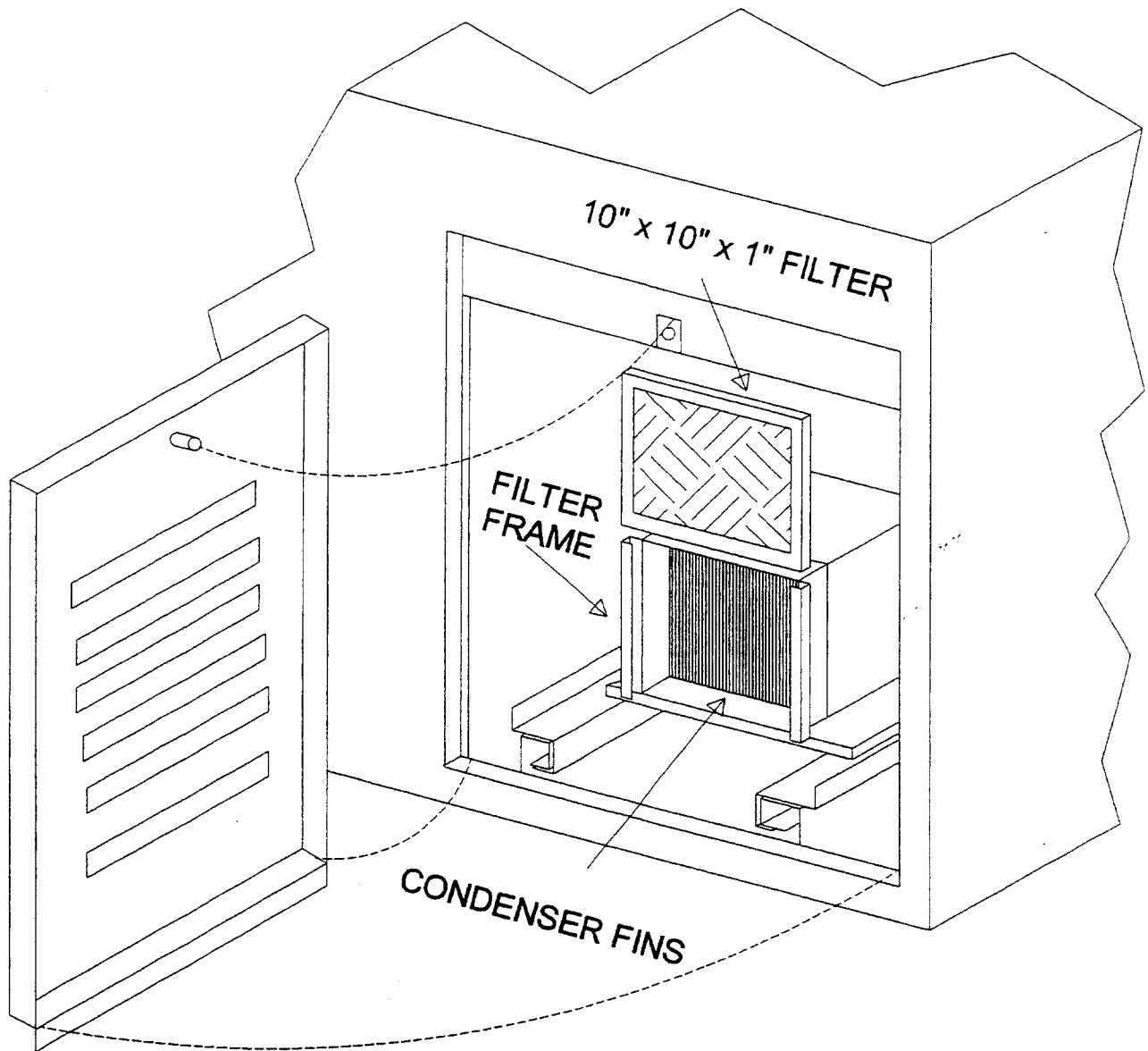

1. TO REMOVE THE LOUVERED PANEL LOOSEN THE THUMB SCREW LOCATED AT THE TOP OF THE PANEL.
2. TILT THE TOP OUT AND LIFT THE PANEL STRAIGHT UP.
3. LIFT THE FILTER STRIAIGHT UP OUT OF THE TRACK.
4. WHEN REPLACING THE FILTER NOTE THE AIR FLOW DIRECTION. IT SHOULD BE POINTING TOWARD THE CONDENSER FINS.

**CAUTION:** THIS FILTER MUST BE CHANGED EVERY 30 DAYS TO ENSURE PROPER OPERATION OF THE UNIT. FAILURE TO CHANGE THE FILTER WILL CAUSE THE COMPRESSOR TO RUN HOT AND CAUSE PREMATURE COMPRESSOR FAILURE. IF THE FILTER IS REMOVED AND NOT REPLACED THE CONDENSER FINS WILL BECOME CLOGGED AND REQUIRE A CHEMICAL RINSE TO CLEAR .

## INSPECTION

UPON RECEIPT, THE CRATE SHOULD BE INSPECTED FOR VISUAL DAMAGE. ANY DAMAGE SHOULD BE REPORTED IMMEDIATELY TO THE CARRIER.

## INSTALLATION INSTRUCTIONS

THE COLOR POINT CPT-RA SERIES ARE COMBINATION HOT/COLD FOOD UNIT DESIGNED FOR DISPENSING OF FOOD.

THE HOT FOOD SECTION IS DESIGNED TO MAINTAIN A PRODUCT TEMPERATURE AT A MINIMUM OF 140 DEGREES FAHRENHEIT DURING SERVING PERIODS.

THE COLD FOOD SECTION OF THIS UNIT IS THE COLOR POINT *Tempest-Aire*® PATENTED REFRIGERATION SYSTEM DESIGNED FOR SHORT TERM DISPLAY AND DISPENSING OF FOOD AND DESERTS. THIS UNIT IS DESIGNED TO MAINTAIN A PRODUCT TEMPERATURE AT A MAXIMUM OF 40 DEGREES FAHRENHEIT FOR PERIODS UP TO FOUR (4) HOURS. THESE UNITS ARE DEPENDENT UPON THE AMBIENT TEMPERATURE IN WHICH THEY ARE INSTALLED AND THE PRODUCT TEMPERATURE WHEN IT IS PLACED IN THE UNITS. THE PRODUCT SHOULD BE CAREFULLY MONITORED AND ROTATED AS NECESSARY TO MEET LOCAL HEALTH REQUIREMENTS.

A HEATED BASE OPTION IS AVAILABLE FOR ON LINE STORAGE OF PRODUCT. THEY SHOULD NOT BE USED AS LONG TERM STORAGE OF BULK PRODUCT.

THE DESIGN OF THIS UNIT ALLOWS FOR A MODULAR OPERATION, WHERE A GROUP OF UNITS CAN BE ARRANGED TO FORM A CAFETERIA SERVING LINE. ROLL THE TABLE INTO A SERVING LINE OR OTHER NEEDED POSITION AND LOCK THE BRAKES ON THE CASTERS.

IF LINE UP LOCKS ARE PROVIDED, SIMPLY ALIGN THE UNITS AND PUSH THE BARREL BOLTS THROUGH THE KEY HOLE SLOTS ON BOTH UNITS THEN TURN THE BOLT DOWN AND PUSH UP THE CAM LOCKING LEVER. TO UNLOCK THE UNITS, REVERSE THIS PROCEDURE.

PLUG THE UNIT INTO THE PROPER GROUNDED ELECTRICAL OUTLET. THE UNIT IS NOW READY FOR OPERATION.

## OPERATING INSTRUCTIONS

### **HOT FOOD SECTION:**

SINCE THE FOOD WARMING UNIT IS DESIGNED FOR HOLDING OR WARMING PRECOOKED FOOD, IT WILL NOT OVERCOOK FOOD WHEN PROPERLY USED. THERE ARE THREE (3) WAYS OF MAINTAINING HOT FOOD IN THE RECEPTACLE: 1. DRY HEATING, 2. STEAM HEATING AND 3. HOT WATER HEATING.

#### **1. DRY HEATING**

- A. PLACE THE CONTROL KNOB ON THE DESIRED POSITION AND ALLOW THE RECEPTACLE TO PREHEAT FOR 15 TO 20 MINUTES.
- B. PLACE THE CONTAINER OF FOOD IN THE RECEPTACLE. KEEP THE FOOD COVERED WHEN NOT SERVING.

### **\*\*\* WARNING \*\*\***

**NEVER POUR COLD WATER INTO A HOT FOOD PAN RECEPTACLE. IF THE WATER BOILS OUT, REFILL WITH HOT WATER OR WAIT UNTIL WELL HAS COOLED DOWN. IF COLD WATER IS Poured ON A HOT, EMPTY RECEPTACLE IT WILL CAUSE THE WELL TO SPLIT OR CRACK.**

## 2. STEAM HEATING

- A. PLACE A FEW QUARTS OF COLD WATER OR HOT WATER (FOR A FASTER PRE-HEAT) IN TO THE RECEPTACLE. THE WATER SHOULD NOT BE IN CONTACT WITH THE FOOD PAN.
- B. PLACE A COVER OR EMPTY FOOD PAN OVER THE RECEPTACLE AND SET THE THERMOSTAT TO A POSITION FOR MODERATE BOILING. ALLOW UNIT TO PREHEAT UNTIL WATER BOILS.
- C. PLACE THE CONTAINER OF FOOD IN THE RECEPTACLE. KEEP FOOD COVERED WHEN NOT BEING SERVED.
- D. ADJUST THE THERMOSTAT TO A POINT WHERE THE WATER JUST BOILS.

## 2. HOT WATER

- A. FILL THE RECEPTACLE WITH HOT WATER TO A DEPTH SO THAT THE FOOD CONTAINER WILL BE IN CONTACT WITH THE WATER.
- B. PLACE A COVER OR EMPTY FOOD PAN OVER THE RECEPTACLE AND SET THE THERMOSTAT TO A POSITION FOR MODERATE BOILING. ALLOW UNIT TO PREHEAT UNTIL WATER BOILS.
- C. LOWER THE SETTING ON THE THERMOSTAT SLIGHTLY SO THAT THE WATER TEMPERATURE IS JUST BELOW THE BOILING POINT.
- D. PLACE THE CONTAINER OF FOOD IN THE RECEPTACLE. KEEP FOOD COVERED WHEN NOT BEING SERVED.

EXACT DIAL SETTING TO MAINTAIN DESIRED FOOD TEMPERATURE WILL VARY WITH THE CHARACTER OF THE FOOD, SUCH AS WHETHER OR NOT THE FOOD IS WATERY OR HAS A CONSIDERABLE AMOUNT OF GREASE. THE MOST SATISFACTORY TEMPERATURE SETTING MUST BE DETERMINED BY EXPERIENCE.

WITH STEAM AND HOT WATER HEATING THE DRYING THE DRYING OUT OF THE FOOD IS MINIMIZED BECAUSE THE WATER VAPOR FROM THE RECEPTACLES CREATES HUMID AIR OVER THE FOOD.

### THERMOSTAT:

THE THERMOSTAT BULB IS CLAMPED TO THE OUTSIDE OF THE DEFLECTOR PLATE ON THE BOTTOM OF THE RECEPTACLE. A CAPILLARY TUBE EXTENDS FROM THE BULB TO THE THERMOSTAT CONTROL. WHENEVER THE HEATING UNIT IS ENERGIZED THE PILOT LIGHT GLOWS AND GOES OFF WHEN THE PRESET TEMPERATURE IS REACHED. THE CYCLING OF THE THERMOSTAT IS THEREFORE INDICATED BY THE PILOT LIGHT.

### SHUTDOWN:

AT THE END OF THE DAY OR SERVING PERIOD, TURN THE THERMOSTAT CONTROLS TO THE OFF POSITION. THIS REMOVES ALL POWER TO THE HEATING UNITS. TO SHUT OFF THE EQUIPMENT FOR LONG PERIODS OF TIME OR TO PREVENT THE UNAUTHORIZED USE OF THE EQUIPMENT PLACE THE CIRCUIT BREAKER TO THE OFF POSITION.

## CLEANING

### HOT FOOD WELLS:

**WET OPERATION** - IF HOT WATER OR STEAM HEATING IS USED, ALL SURFACES ARE COVERED WITH A FILM OF WATER. FOOD SPILLAGE INTO THE RECEPTACLE WILL NOT STICK OR CARBONIZE. IT WILL DROP IN TO THE WATER AN FLOAT OR SETTLE TO THE BOTTOM. TO CLEAN THE RECEPTACLE, REMOVE THE WATER BY OPENING THE DRAIN VALVE LOCATED UNDER THE UNIT

AND DRAIN THE WATER IN TO A SUITABLE CONTAINER AND SPONGE OUT THE REMAINING WATER. WASH THE RECEPTACLE WITH A MILD DETERGENT AND HOT WATER, RINSE AND DRY. SEE THE FOLLOWING SECTION ON "HOW TO CLEAN STAINLESS STEEL" FOR SPECIFIC RECOMMENDATIONS.

**DRY OPERATION** - WHEN THE FOOD WARMER IS USED DRY, FOOD SPILLAGE ON THE HOT SURFACES WILL BURN AND STICK. THE SAME COMMERCIAL CLEANERS USED ON STAINLESS STEEL UTENSILS MAY BE USED TO CLEAN THE RECEPTACLE. WASH THE INTERIOR SURFACES WITH WATER AND A MILD DETERGENT TO REMOVE DISCOLORATION. RINSE WITH PLAIN WATER AND DRY WITH AN ABSORBENT CLOTH. THE BOTTOM OF THE RECEPTACLE MAY TAKE ON A STRAW COLORED APPEARANCE WHEN IT IS USED DRY. THIS IS DUE TO THE INTENSE HEAT. THE DISCOLORATION WILL NOT COME OFF WITH NORMAL CLEANING PROCEDURES BUT DOES NOT POSE ANY PERFORMANCE OR HEALTH PROBLEMS. SEE THE SECTION ON "HOW TO CLEAN STAINLESS STEEL" FOR SPECIFIC RECOMMENDATIONS.

**\*\*\* WARNING \*\*\***

**DO NOT USE HARSH CHEMICALS, ACIDS OR ALKALIS IN CLEANING THIS TABLE OR HEATING RECEPTACLES. WITH ANY CLEANERS, READ INSTRUCTIONS CAREFULLY AND DILUTE AS INSTRUCTED BEFORE APPLYING TO STAINLESS STEEL EQUIPMENT.**

**THE FOOD WARMING RECEPTACLE IS MADE OF STAINLESS STEEL, BUT USE CARE DURING THE CLEANING OPERATION. HEAVY OBJECTS SHOULD NOT BE DROPPED IN THE RECEPTACLE.**

**CONTROL KNOB:**

TO CLEAN THE THERMOSTAT KNOB, PULL THE KNOB OUTWARD TO REMOVE IT FROM THE SHAFT. WASH THE KNOB WITH MILD SOAP AND WATER, RINSE AND DRY WITH A SOFT CLOTH. DO NOT USE ABRASIVE CLEANERS ON THE PLASTIC SURFACES OF THE KNOB.

**FIBERGLASS BODY:**

THE FIBERGLASS BODY SHOULD BE CLEANED WITH A MILD NON-ABRASIVE CLEANER AND A SOFT CLOTH.

**OPERATING INSTRUCTIONS**

**COLD FOOD SECTION  
ICE COOLED:**

THE ICE COOLED SECTION OF THIS UNIT IS SUPPLIED WITH A 7" DEEP STAINLESS STEEL PAN DESIGNED TO HOLD STANDARD FOOD SERVICE PANS. THE UNIT IS PROVIDED WITH A 1" DEEP PERFORATED FALSE BOTTOM TO ALLOW FOR ICE MELT OFF. THE UNIT SHOULD BE PACKED IN ICE WHERE THE ICE IS IN CONTACT WITH THE FOOD SERVICE PANS.

**COLD FOOD SECTION  
MECHANICALLY REFRIGERATED:  
START UP:**

THE REFRIGERATION SYSTEM SUPPLIED WITH THESE SYSTEMS ARE OF THE HERMETIC TYPE. REFRIGERANT IS METERED BY EXPANSION VALVES WHICH ARE LOCATED IN THE COMPRESSOR HOUSING OF THE CPT-R SERIES AND INSIDE THE BLOWER COIL OF THE REFRIGERATED BASE OPTION. EACH REFRIGERATION SYSTEM IS SELF CONTAINED AND HAS BEEN LEAK TESTED, CHARGED WITH REFRIGERANT AND OPERATED TO ENSURE THE PROPER OPERATION AND SETTING OF THE CONTROLS.

ENERGIZE THE UNIT BY ATTACHING THE PLUG TO AN APPROPRIATE ELECTRICAL SUPPLY AND TURNING ON THE SERVICE SWITCH LOCATED IN THE COMPRESSOR COMPARTMENT. AFTER APPROXIMATELY ONE (1) HOURS OF OPERATION THE UNIT WILL BE READY FOR USE.

## **OPERATION:**

IN THE CPT-R SERIES UNITS THE LOW PRESSURE CONTROL (PHYSICALLY LOCATED IN THE FRONT OF THE COMPRESSOR COMPARTMENT) CONTROLS THE TEMPERATURE OF THE REFRIGERATION SYSTEM. THE LOW PRESSURE CONTROL IS ADJUSTED BY TURNING THE KNOBS ON THE TOP OF IT WITH A SCREWDRIVER. THE CUT IN IS SET AT THE FACTORY AT +40 PSI AND THE DIFFERENTIAL IS SET AT 15. RAISING THE CUT IN WILL CAUSE THE DISPENSER TEMPERATURE TO BE LOWER. LOWERING THE CUT IN WILL ALSO CAUSE THE COMPRESSOR TO RUN CONTINUOUSLY, WHICH WILL SHORTEN THE EXPECTED LIFE OF THE COMPRESSOR. THE DIFFERENTIAL SHOULD NOT BE SET LOWER THAN 10, AS THIS WILL CAUSE THE COMPRESSOR TO SHORT CYCLE, WHICH CAN LEAD TO PREMATURE COMPRESSOR FAILURE.

## **CLEANING:**

THE OUTSIDE OF THIS UNIT IS FABRICATED FROM FIBERGLASS AND SHOULD BE CLEANED WITH A MILD NON-ABRASIVE CLEANER. NORMAL LOTION SOAP THAT IS USED IN SINKS IS SATISFACTORY.

THE INNER LINER OF THIS UNIT IS FABRICATED OF 304 STAINLESS STEEL. PLEASE SEE "HOW TO CLEAN STAINLESS STEEL" IN THIS MANUAL. NOTE THAT THIS IS A VERY BROAD SECTION ON CLEANING AND THE TYPE OF EQUIPMENT AND END USE SHOULD BE KEPT IN CONSIDERATION BEFORE SELECTING ANY SPECIAL CLEANERS.

## **ELECTRICAL SYSTEM:**

### **\*\*\*\*\* WARNING \*\*\*\*\***

IN ORDER TO PREVENT ANY ELECTRICAL ACCIDENTS, THIS REFRIGERATION SYSTEM SHOULD BE INSTALLED AND SERVICED BY QUALIFIED MAINTENANCE PERSONNEL ONLY PER NATIONAL ELECTRICAL CODE STANDARDS.

### **\*\*\*\*\* WARNING \*\*\*\*\***

INDIVIDUAL BREAKERS OR FUSES SHOULD BE PROVIDED FOR EACH COMPRESSOR MOTOR. GROUP FUSING, WHERE TWO OR MORE COMPRESSORS ARE INSTALLED ON ONE FUSE OR BREAKER IS **\*\*NOT RECOMMENDED\*\***. REFER TO THE NATIONAL ELECTRICAL CODE FOR APPROPRIATE LINE FUSE OR BREAKER SIZE.

## **OPTIONAL ITEMS:**

THE CPT-R SERIES UNITS MAY BE PURCHASED WITH AN OPTIONAL REFRIGERATED BASE. THIS BASE IS DESIGNED FOR ON LINE STORAGE OF PRODUCT AND SHOULD NOT BE USED FOR LONG TERM STORAGE OF BULK PRODUCT. THE REFRIGERATED BASE WORKS IN CONJUNCTION WITH THE COLD PAN SYSTEM AND CAN ONLY BE OPERATED WHEN THESE SYSTEMS ARE FUNCTIONING.

LIGHTS AND ELECTRICAL RECEPTACLES MAY ALSO BE PURCHASED AS PART OF THIS EQUIPMENT. WHEN THESE OPTIONS ARE PROVIDED THE ELECTRICAL CIRCUITS WILL BE SEPARATELY FUSED WITH **CLASS "G" FUSES**. IF FUSES MUST BE REPLACED **REPLACE WITH THE SAME TYPE AND AMPERAGE FUSE**.

### **\*\*\* CAUTION \*\*\***

**DO NOT USE BLEACHES, ABRASIVE CLEANERS OR ABRASIVE CLOTHS OR PADS AS THEY MAY DISCOLOR AND SCRATCH THE FIBERGLASS. DO NOT USE HARSH CHEMICALS, ACIDS OR ALKALIS IN THE CLEANING OF THE FIBERGLASS.**

**PLEXIGLASS SHIELDS:**

USE A MILD SOAP AND A SOFT CLOTH WHEN CLEANING THE PLEXIGLASS SURFACES. WIPING THE SURFACE WITH A DRY CLOTH CAN CAUSE SCRATCHES. FOR BEST RESULTS USE "NOVUS PLASTIC POLISH NO. 1".

**DO NOT USE WINDOW CLEANING SPRAY OR KITCHEN SCOURING COMPOUNDS.** PRODUCTS WITH A HIGH ALCOHOL CONTENT CAN CAUSE SURFACE FISSURES COMMONLY REFERRED TO AS "CRAZING". THIS WILL OCCUR IN ANY SPOT THAT HAS BEEN SUBJECT TO STRESSES, SUCH AS CHIPPED OR BURNED SAW CUTS, CRACKED HOLES FLAME POLISHED EDGES, FORMED EDGES, ETC.

**\*\*\* WARNING \*\*\***

**IN ORDER TO PREVENT ANY ELECTRICAL ACCIDENTS, THIS EQUIPMENT SHOULD BE INSTALLED AND SERVICED BY QUALIFIED MAINTENANCE PERSONNEL ONLY PER NATIONAL ELECTRICAL CODE STANDARDS.**

VARIOUS OPTIONS MAY BE PURCHASED WITH THIS EQUIPMENT. WHEN THESE OPTIONS ARE PROVIDED THE ELECTRICAL CIRCUITS MAY BE SEPARATELY FUSED WITH CLASS "G" FUSES. IF FUSES MUST BE REPLACED **REPLACE WITH THE SAME TYPE AND AMPERAGE FUSE.**

## HOW TO CLEAN STAINLESS STEEL

THE FOLLOWING INFORMATION WAS TAKEN FROM A PAMPHLET BY MR. RICHARD E. PARET, STAINLESS STEEL SPECIALIST, AMERICAN IRON AND STEEL INSTITUTE.

STAINLESS STEEL IS ONE OF THE EASIEST MATERIALS TO CLEAN AND KEEP CLEAN.

THE REASONS FOR STAINLESS STEEL'S EASE OF CLEANING ARE EASY TO SEE; THEY LIE IN THE NATURE OF THE METAL ITSELF.

1. IT'S HARD, TOUGH SURFACE. STAINLESS STEEL WILL WORK HARDER, THAT IS, THE MORE IT IS USED, THE MORE RESISTANT TO WEAR IT BECOMES. STAINLESS STEEL WILL NOT DEVELOP ROUGH SPOTS THAT HARBOR BACTERIA AND SOIL.
2. HIGH CORROSIVE RESISTANCE STAINLESS STEEL IS PRACTICALLY UNTOUCHED BY THE CORROSIVE ATTACKS OF MOISTURE, DETERGENTS, FOOD ACIDS, BLOOD SALTS AND OTHER CORRODENTS CONNECTED WITH FOOD PREPARATION. THIS MEANS THAT STAINLESS STEEL ALWAYS HAS A BRIGHT SURFACE FREE FROM OXIDES THAT CAN AFFECT THE FLAVOR OF FOODS.

THE SECRET OF MAINTAINING STAINLESS STEEL IS FREQUENT, SCHEDULED CLEANING THAT WILL PREVENT BUILD UP OF SURFACE DEPOSITS. SURFACE DEPOSITS, IF ALLOWED TO REMAIN FOR LONG PERIODS OF TIME CAN HARM STAINLESS STEEL. STAINLESS STEEL THRIVES ON EXPOSURE TO AIR; UNDER CERTAIN CONDITIONS, THE LENGTHY DEPRIVATION OF OXYGEN BY HEAVY SOIL DEPOSITS CAN CAUSE LOCALIZED PITTING OR STAINING.

NEGLECTING THE MATERIAL IN THIS MANNER IS DEFINITE ABUSE WHICH EVEN STAINLESS STEEL IS NOT IMMUNE.

### TWO BASIC RULES:

1. CLEAN FREQUENTLY, AND ON A FIXED SCHEDULE.
2. SELECT THE SIMPLEST METHOD.

TO REMOVE ORDINARY DIRT AND FOOD RESIDUE FROM STAINLESS STEEL EQUIPMENT THAT OPERATES AT LOW TEMPERATURES, USE ORDINARY SOAP AND WATER AND APPLY WITH A SPONGE, FIBER BRUSH OR CLOTH. TO HASTEN ACTION, ADD EITHER SODA ASH, BAKING SODA, BORAX OR ANY OF SEVERAL NON-ABRASIVE COMMERCIAL CLEANSING AGENTS.

TO REMOVE SPLATTER OR CONDENSED VAPOR WHICH HAVE "BAKED" ONTO THE EQUIPMENT, THE TREATMENT OUTLINED ABOVE IS OFTEN SUFFICIENT. IN OTHER CASES A GENTLE TO VIGOROUS POLISHING ACTION MAY BE NECESSARY.

FIRST TRY A PASTE MADE WITH WATER AND AMMONIA AS THE LIQUID AND EITHER MAGNESIUM OXIDE, FINELY POWDER PUMICE OR FRENCH CHALK AS THE SOLID. YOU CAN ALSO USE ONE OF SEVERAL COMMERCIAL CLEANERS LISTED IN THE FOLLOWING TABLE.

RUB AS GENTLY AS POSSIBLE IN THE DIRECTION OF THE POLISHING MARKS ON THE STEEL, USING A SOFT CLOTH. FOR MORE RESISTANT DEPOSITS, USE A STAINLESS STEEL SCOURING SPONGE OR STAINLESS STEEL WOOL OF THE FINEST POSSIBLE TEXTURE.

### WHAT NOT TO DO:

DO NOT USE COMMON STEEL WOOL, SCOURING PADS, SCRAPERS, WIRE BRUSHES, FILES OR OTHER STEEL TOOLS, SINCE THESE CAN MAR THE STAINLESS STEEL. THESE PARTICLES WILL EVENTUALLY RUST AND STAIN THE SURFACE, AND YOU MAY HAVE TO REFINISH IT.

**HOW TO CLEAN STAINLESS STEEL**  
**(CONT.)**

SLIGHTLY DARKENED AREAS SOMETIMES APPEAR ON STAINLESS STEEL SURFACES WHERE HEAT HAS BEEN APPLIED DURING FABRICATION OR IN SERVICE.

THESE ARE CAUSED BY THICKENING OF THE PROTECTIVE SURFACE OF STAINLESS STEEL, AND ARE NOT HARMFUL. REMOVAL CALLS FOR ENERGETIC SCOURING, AGAIN USING A STAINLESS STEEL WOOL OR SCOURING PAD, COMBINED WITH A SCOURING POWDER OR ONE OF THE HEAT-TINT REMOVERS LISTED IN THE TABLE.

THREE RULES WILL PREVENT HEAT TINTING:

- 1) USE ONLY ENOUGH HEAT TO DO THE JOB EFFICIENTLY.
- 2) DO NOT APPLY HEAT TO EMPTY EQUIPMENT.
- 3) AVOID CONCENTRATING HEAT ON A SMALL AREA.

**\*\*\* CAUTION IS ADVISED \*\*\***

IN STERILIZING STAINLESS STEEL EQUIPMENT, PAY PARTICULAR ATTENTION TO AGENTS CONTAINING CHLORINE COMPOUNDS SUCH AS POTASSIUM HYPOCHLORITE. THESE COMPOUNDS MAY BREAK DOWN AND RELEASE FREE CHLORINE, OR HYDROLYZE TO FORM HYDROCHLORIC ACID.

STAINLESS STEEL RESISTS ATTACK BY SUCH COMPOUNDS FOR UP TO TWO HOURS. SEVERE LOCALIZED PITTING MAY OCCUR FROM LONGER EXPOSURE. FOR SAFE USE OF THESE AGENTS, KEEP CONTACT TIME SHORT, FLUSH THOROUGHLY WITH WATER, AND OPERATE EQUIPMENT NORMALLY BETWEEN APPLICATIONS. USING THESE PRECAUTIONS, THE STERILIZATION PROCESS CAN BE REPEATED ANY NUMBER OF TIMES.

## CLEANERS AND THEIR EFFECT ON STAINLESS STEEL

<u>Cleaning agent</u>	<u>Method of Application</u>	<u>Effect on finish</u>
1. Tightly adhering deposits of "baked on" spatter, oil, grease, weather stain, dyes or other light discoloration may be removed with any of the following cleaners.		
Grade FFF Italian pumice whitening or bon ami	scour or rub with damp cloth	satisfactory for all finishes use light pressure on no.7
Liquid NuSteel	scour with small amount on dry cloth	satisfactory for all finishes if rubbing pressure is light
Paste NuSteel or Temp	scour with small amount on dry cloth	satisfactory for no. 4 finish. Will scratch no.7
House hold cleaners such as Old Dutch, Sunbrite, Wyandotte, Bob-O, Gold Dust and Sapolio	Rub with damp cloth	Will scratch no. 4 finish slightly
Grade F Italian Pumice	Rub with damp cloth	Will scratch no.4 finish slightly
Cooper's stainless steel polish	Rub with damp cloth	satisfactory for no.4 finish
Allen stainless steel polish	Rub with damp cloth	Scratches considerably but leaves mirror reflection
Best Effect Chemical Co. cleaner & Passivator	Rub with damp cloth	May scratch no.4 finish slightly
2. Heat tint or heavy discoloration with the following (see notes below)		
Allen stainless polish	Small amount on damp cloth	Excellent heat tint remover
Birdsall's "Staybright"	Rub with damp cloth	Very good for heat tint removal. Does not scratch no.4finish but does scratch no.7
Wyandotte or Bob-O	Rub with damp cloth	Good for heat tint removal
Oxalic acid (use warm) Or 15% nitric acid	Swab or immerse. Always follow with a 5% sodium carbonate or neutralizer rinse	Good discoloration remover
Best Effect Chemical Co. cleaner & Passivator	Rub with damp cloth	May scratch no 4 but leaves clean surface

**CLEANERS AND THEIR EFFECT ON**  
**STAINLESS STEEL**  
**(Cont.)**

Cleaning agent	Method of Application	Effect on Finish
<p>3. The following detergents and solvents are excellent removers of grease, oil and fatty acids, where swabbing or rubbing is not practical.</p>		
<p>4 to 6% solution of            (sodium Metasilicate)            (Trisodium Phosphate)            (Sodium Metaphosphate)            (Sodium Pyrophosphate)</p>		<p>All excellent            removers of grease,            oil, and milkstone</p>
<p>5-15% caustic soda (hot or cold)</p>		<p>Will remove grease            and milkstone</p>
<p>4. The following organic solvents may be used for removing oils and grease deposits:</p>		
<p>Carbon-tetrachloride, Naphtha, Trichlorethylene            Acetone, Kerosene, Gasoline, Ether, Alcohol, Benzene</p>		<p>No affect on finish,            however, take all            precautions against            fire.</p>

**Notes: ordinary wool or steel brushes should never be used on stainless steel surfaces. Particles of steel may become imbedded in the stainless steel surface, and rusting of these particles will eventually appear as stains. Use stainless steel wool or sponge on stainless steel equipment. Heat tint removers will usually scratch stainless steel surfaces. This, however, is necessary in removing heat tint by hand. Oakite, a fibrous material, may be used in place of metal sponges or cloth pads for applying cleaners and polishes. This material is effective in aiding in removal of milkstone.**

**For heavy hard water deposits, 15-20% (by volume) nitric acid is very effective. Acid treatment should be followed by a thorough water rinse.**

**The action of soldering fluxes should be neutralized immediately with a 5% sodium carbonate solution.**

**Soap and water followed by a water rinse will not harm stainless steel.**

## PREVENTATIVE MAINTENANCE OF COLORPOINT EQUIPMENT

### HOT FOOD SECTION:

*To insure that your equipment will continue to operate properly, please follow these simple steps:*

- #1 The food receptacle wells should be clean thoroughly every day. Food spillage left in the pans such as tomato paste can cause damage to the unit. The acidic base of foods over time can cause pitting of the units. For more cleaning information on these models, see the section on "HOW TO CLEAN STAINLESS STEEL" in this manual.
- #2 Always wipe the unit down with a damp cloth. Do not spray water directly in control panel areas or on areas with exposed heating elements.

### COLD FOOD SECTION:

*To insure that your equipment will continue to operate properly, please follow these simple steps:*

- #3 Make sure that the **FILTER** in the louvered panel OF CTP-R SERIES is always kept clean of dust and dirt. Failure to do this will cause compressor to overheat and may cause compressor failure, and will also **VOID ANY FACTORY WARRANTY** on compressor.
- #4 **MODELS CPT-R SERIES.** To insure proper operation of these units, periodically check the evaporator unit coolers to ensure that the air intakes and the discharge areas are kept clean and clear. If the air fan intakes or discharge become blocked with wrappings or debris this will cause the coils located inside the unit coolers to freeze and the temperature in the unit will rise.

For more cleaning information on these models, see the section on "CLEANING" in this manual.

LOW TEMP INDUSTRIES  
TYPICAL FOLD DOWN BRACKET  
USED FOR BOTH TRAY SLIDES  
AND CUTTING BOARDS

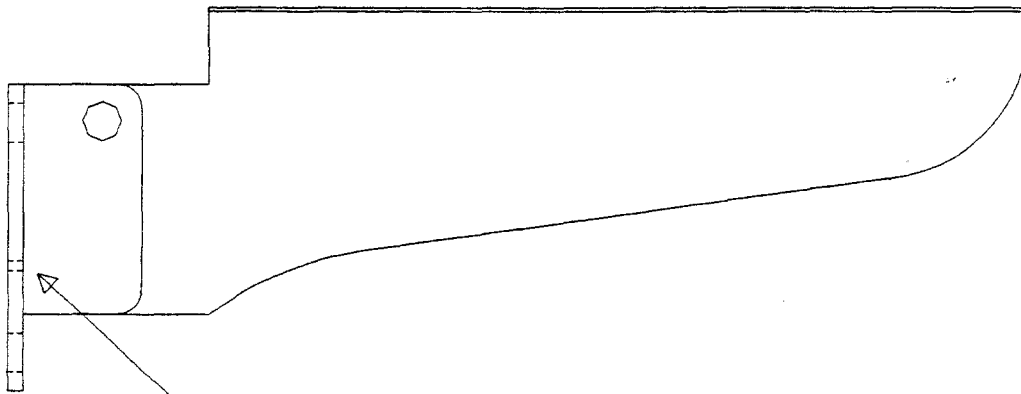

BRACKET LEVEL ADJUSTMENT SCREW  
LOCATED ON HEAL PLATE BETWEEN  
BRACKET SUPPORTS.

NO. 8-32 SET SCREW, REQUIRES A  
2 mm ALLEN WRENCH.

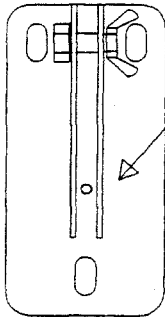

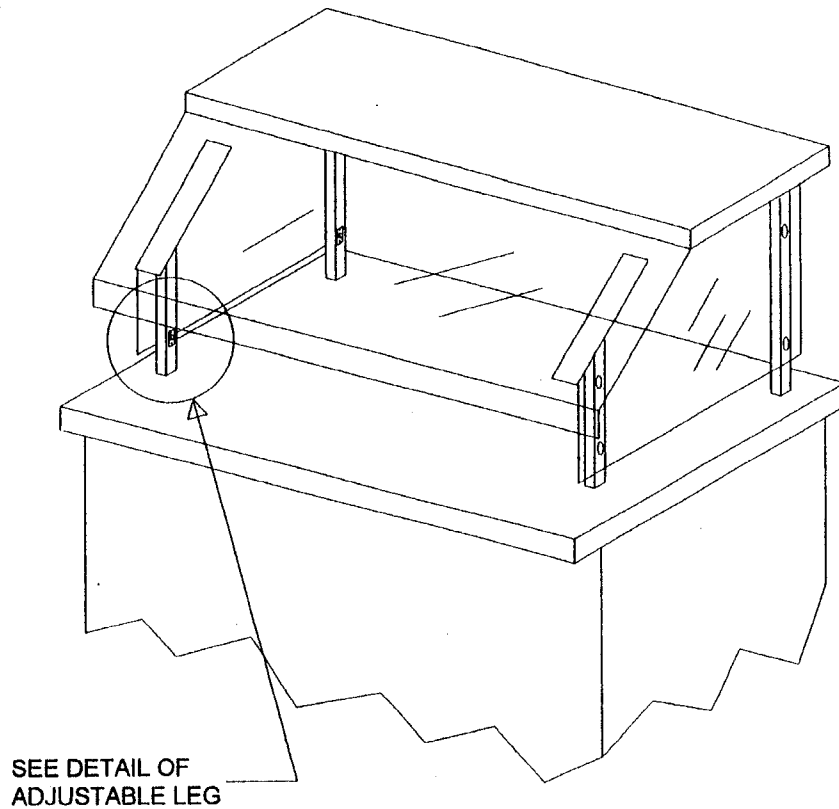

SEE DETAIL OF  
ADJUSTABLE LEG

**ADJUSTABLE BUFFET FOOD PROTECTOR**

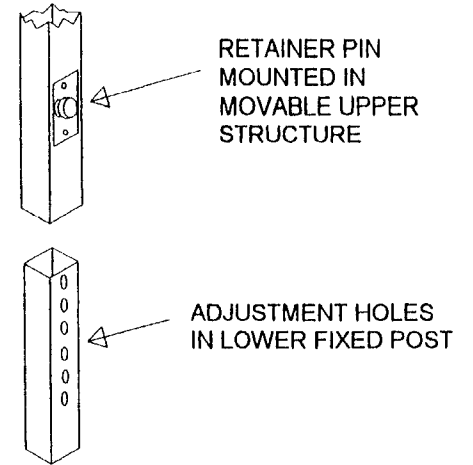

ADJUSTABLE LEG DETAIL

**ADJUSTABLE BUFFET SHIELD INSTRUCTIONS**

THIS UNIT IS PROVIDED WITH AN ADJUSTABLE BUFFET SHIELD. THE TOTAL ADJUSTMENT IS SIX (6) INCHES FROM ITS LOWEST POSITION IN ONE (1) INCH INCREMENTS.

TO ADJUST THE SHIELD PULL THE RETAINER PIN LOCATED ON EACH POST OUT. THE PIN WILL REMAIN IN THE OUT POSITION BY ROTATING IT ONE QUARTER (1/4) TURN. RAISE THE SHIELD TO THE DESIRED HEIGHT AND TURN RETAINER BACK TO ITS ORIGINAL POSITION.

NOTE! WHEN RAISING THE SHIELD BOTH ENDS MUST BE LIFTED AT THE SAME TIME. DO NOT FORCE THE POST OR PUT THE SYSTEM IN A BIND.

IF ELECTRICAL DEVICES ARE PROVIDED ON THE SHIELD, LOOSEN THE LOCKING COLLAR ON THE WIRE CHASE POST WHICH IS LOCATED BETWEEN THE MAIN SUPPORT POST AND SET IT FLUSH WITH THE COUNTER TOP.

# COLORPOINT

3-95

BY LOW TEMP INDUSTRIES  
JONESBORO, GEORGIA

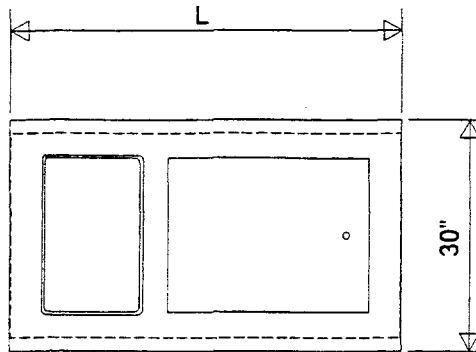

TOP VIEW

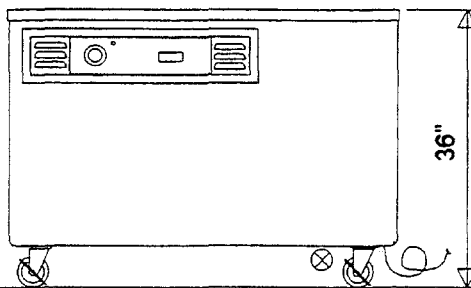

SIDE VIEW

BY LOW TEMP INDUSTRIES  
CPT SERIES HOT/COLD  
COMBINATION TABLE  
WITH ICE COOLED COLD PAN

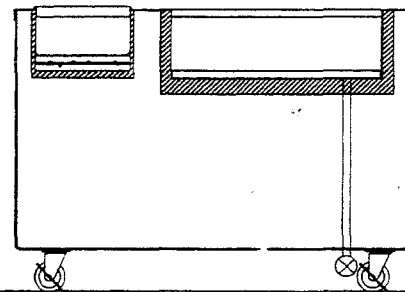

SECTIONAL VIEW

MODEL	WELLS		L	AMPS 208/1PH	NEMA PLUG TYPE
	HOT	COLD			
CPT-51-EB	1	2	50	4.8	6-15
CPT-61-EB	1	3	60	4.8	6-15P
CPT-62-EB	2	2	60	9.6	6-15P
CPT-71-EB	1	4	74	4.8	6-15P
CPT-72-EB	2	3	74	9.6	6-15P
CPT-73-EB	3	2	74	14.4	6-20P
CPT-91-EB	1	5	96	4.8	6-15P
CPT-92-EB	2	4	96	9.6	6-15P
CPT-93-EB	3	3	96	14.4	6-20P
CPT-94-EB	4	2	96	19.6	6-30P

TOP: 14 GAUGE STAINLESS STEEL WITH SQUARE TURN DOWNS ON ALL SIDES AND CORNERS FULLY WELDED AND GROUND AND POLISHED TO A #4 SATIN FINISH WITH ALL EDGES HAVING A #7 HI-LITE FINISH.

BODY: SEAMLESS MOLDED FIBERGLASS (F.R.P.) WITH SMOOTH EXTERIOR SURFACE AND ROUNDED CORNERS. ALL FIBERGLASS TO BE FLAME RETARDANT PER SPECIFICATIONS ASTM-E-162 HAVING A FLAME SPREAD OF 25 OR LESS.

MECHANICALLY COOLED COLD PAN: TO BE A WATERTIGHT INTERIOR LINER OF STAINLESS STEEL 6" DEEP. TO BE REFRIGERATED BY 1/2" COPPER COILS ATTACHED TO THE BOTTOM SIDE OF THE INTERIOR PAN. THE PAN IS FULLY INSULATED WITH URETHANE INSULATION AND THE TOP SHALL BE SEPERATED FROM THE PAN BY A FULL PERIMETER BREAKER STRIP. THE COLD PAN SHALL HAVE A 1" OPEN BRASS DRAIN WITH EXTENSION TO SHUT OFF VALVE BELOW BODY

COMPRESSOR COMPARTMENT: SHALL HAVE TWO (2) STAINLESS STEEL EXTERIOR FRAMES COMPLETE WITH REMOVABLE LOUVERS TO PROVIDE A POSITIVE CROSS VENTILATION IN THE COMPARTMENT.

CONDENSING UNIT: FULLY HERMETIC TYPE R-22 SYSTEM. COMPLETELY PREPIPED WITH ALL NECESSARY CONTROLS FOR PROPER OPERATION. FACTORY TESTED AND MADE READY TO PLUG IN ON JOB SITE. THE CONDENSER (INTAKE SIDE) OF THE CONDENSING UNIT IS PROVIDED WITH A FILTER MEDIA TO HELP PROTECT THE CONDENSER FINS FROM BECOMMING CLOGGED.

DRY/MOIST HOT FOOD WELLS: TO BE BOTTOM MOUNTED AND THE OPENING SHALL BE DIE STAMPED WITH A 1/4" RAISED BEADED EDGE. ALL FOOD WELLS TO BE CENTERED ON THE TOP. EACH WELL SHALL BE SUPPLIED WITH A TUBULAR TYPE RESISTIVE HEATING ELEMENT MOUNTED BELOW THE STAINLESS STEEL WELL AND BE CONTROLLED BY INDIVIDUAL CAPILARY TYPE THERMOSTAT. MAIN POWER IS WIRED THROUGH A CIRCUIT BREAKER FOR CURRENT OVERLOAD PROTECTION.

CASTERS: 4" DIAMETER BALL BEARING, SWIVEL TYPE, NON MARKING WITH BRAKES ON ALL WHEELS. CASTERS TO BE MOUNTED WITH INTERNAL AND EXTERNAL BRACING FOR MAXIMUM STRESS RELIEF.

APPROVALS: THIS UNIT IS LISTED BY UNDERWRITERS LABORATORIES FOR SAFETY AND CLASSIFIED BY UNDERWRITERS LABORTORIES BY SANITION UNDER NSF STD. 2 AND SHALL BEAR BOTH SEALS.

# COLORPOINT

3-95

BY LOW TEMP INDUSTRIES  
JONESBORO, GEORGIA

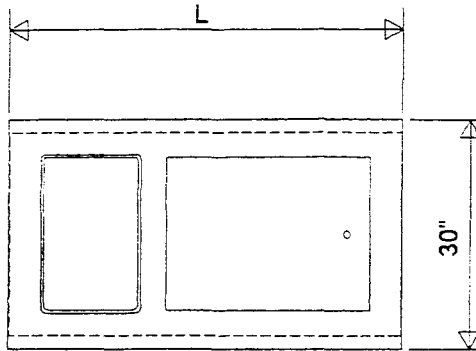

TOP VIEW

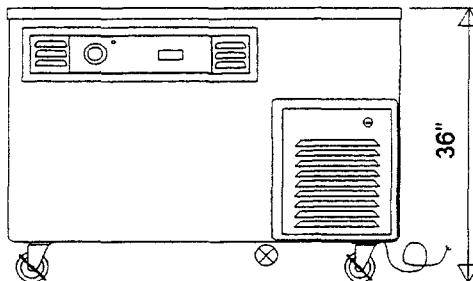

SIDE VIEW

BY LOW TEMP INDUSTRIES  
CPT-R SERIES HOT/COLD  
COMBINATION TABLES WITH  
MECHANICALLY REFRIGERATED COLD PAN

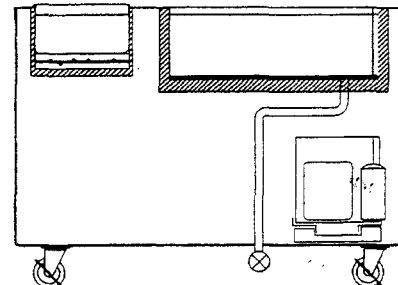

SECTIONAL VIEW

MODEL	WELLS		L	AMPS 120/208/1PH	NEMA PLUG TYPE
	HOT	COLD			
CPT-51-R-EB	1	2	50	10.3	14-20P
CPT-61-R-EB	1	3	60	10.3	14-20P
CPT-62-R-EB	2	2	60	15.1	14-20P
CPT-71-R-EB	1	4	74	10.3	14-20P
CPT-72-R-EB	2	3	74	15.1	14-20P
CPT-73-R-EB	3	2	74	19.9	14-30P
CPT-91-R-EB	1	5	96	10.3	14-20P
CPT-92-R-EB	2	4	96	15.1	14-20P
CPT-93-R-EB	3	3	96	19.9	14-30P
CPT-94-R-EB	4	2	96	24.8	14-50P

TOP: 14 GAUGE STAINLESS STEEL WITH SQUARE TURN DOWNS ON ALL SIDES AND CORNERS FULLY WELDED AND GROUND AND POLISHED TO A #4 SATIN FINISH WITH ALL EDGES HAVING A #7 HI-LITE FINISH.

BODY: SEAMLESS MOLDED FIBERGLASS (F.R.P.) WITH SMOOTH EXTERIOR SURFACE AND ROUNDED CORNERS. ALL FIBERGLASS TO BE FLAME RETARDANT PER SPECIFICATIONS ASTM-E-162 HAVING A FLAME SPREAD OF 25 OR LESS.

MECHANICALLY COOLED COLD PAN: TO BE A WATERTIGHT INTERIOR LINER OF STAINLESS STEEL 6" DEEP. TO BE REFRIGERATED BY 1/2" COPPER COILS ATTACHED TO THE BOTTOM SIDE OF THE INTERIOR PAN. THE PAN IS FULLY INSULATED WITH URETHANE INSULATION AND THE TOP SHALL BE SEPERATED FROM THE PAN BY A FULL PERIMETER BREAKER STRIP. THE COLD PAN SHALL HAVE A 1" OPEN BRASS DRAIN WITH EXTENSION TO SHUT OFF VALVE BELOW BODY.

COMPRESSOR COMPARTMENT: SHALL HAVE TWO (2) STAINLESS STEEL EXTERIOR FRAMES COMPLETE WITH REMOVABLE LOUVERS TO PROVIDE A POSITIVE CROSS VENTILATION IN THE COMPARTMENT.

CONDENSING UNIT: FULLY HERMETIC TYPE R-22 SYSTEM. COMPLETELY PREPARED WITH ALL NECESSARY CONTROLS FOR PROPER OPERATION. FACTORY TESTED AND MADE READY TO PLUG IN ON JOB SITE. THE CONDENSER (INTAKE SIDE) OF THE CONDENSING UNIT IS PROVIDED WITH A FILTER MEDIA TO HELP PROTECT THE CONDENSER FINS FROM BECOMMING CLOGGED.

DRY/MOIST HOT FOOD WELLS: TO BE BOTTOM MOUNTED AND THE OPENING SHALL BE DIE STAMPED WITH A 1/4" RAISED BEADED EDGE. ALL FOOD WELLS TO BE CENTERED ON THE TOP. EACH WELL SHALL BE SUPPLIED WITH A TUBULAR TYPE RESISTIVE HEATING ELEMENT MOUNTED BELOW THE STAINLESS STEEL WELL AND BE CONTROLLED BY INDIVIDUALL CAPILARY TYPE THERMOSTAT. MAIN POWER IS WIRED THROUGH A CIRCUIT BREAKER FOR CURRENT OVERLOAD PROTECTION.

CASTERS: 4" DIAMETER BALL BEARING SWIVEL TYPE, NON MARKING WITH BRAKES ON ALL WHEELS. CASTERS TO BE MOUNTED WITH INTERNAL AND EXTERNAL BRACING FOR MAXIMUM STRESS RELIEF.

APPROVALS: THIS UNIT IS LISTED BY UNDERWRITERS LABORATORIES INC. FOR SAFETY AND CLASSIFIED BY UNDERWRITERS LABORATORIES INC. FOR SANITATION UNDER NSF STANDARD 2 AND SHALL BEAR BOTH SEALS.

SPECIFIC PLUG WILL VARY DEPENDING UPON OPTIONS PURCHASED. CONSULT FACTORY FOR SPECIFIC PLUG AND POWER REQUIREMENTS

THREE (3) HOT FOOD UNIT SHOWN. MAY BE PROVIDED WITH ONE (1) TO SIX (6) UNITS. STANDARD ELECTRICAL SPECIFICATION IS 208V/1000W EA OTHER VOLTAGE AND WATTAGES AVAILABLE. CONSULT FACTORY FOR SPECIFICS.

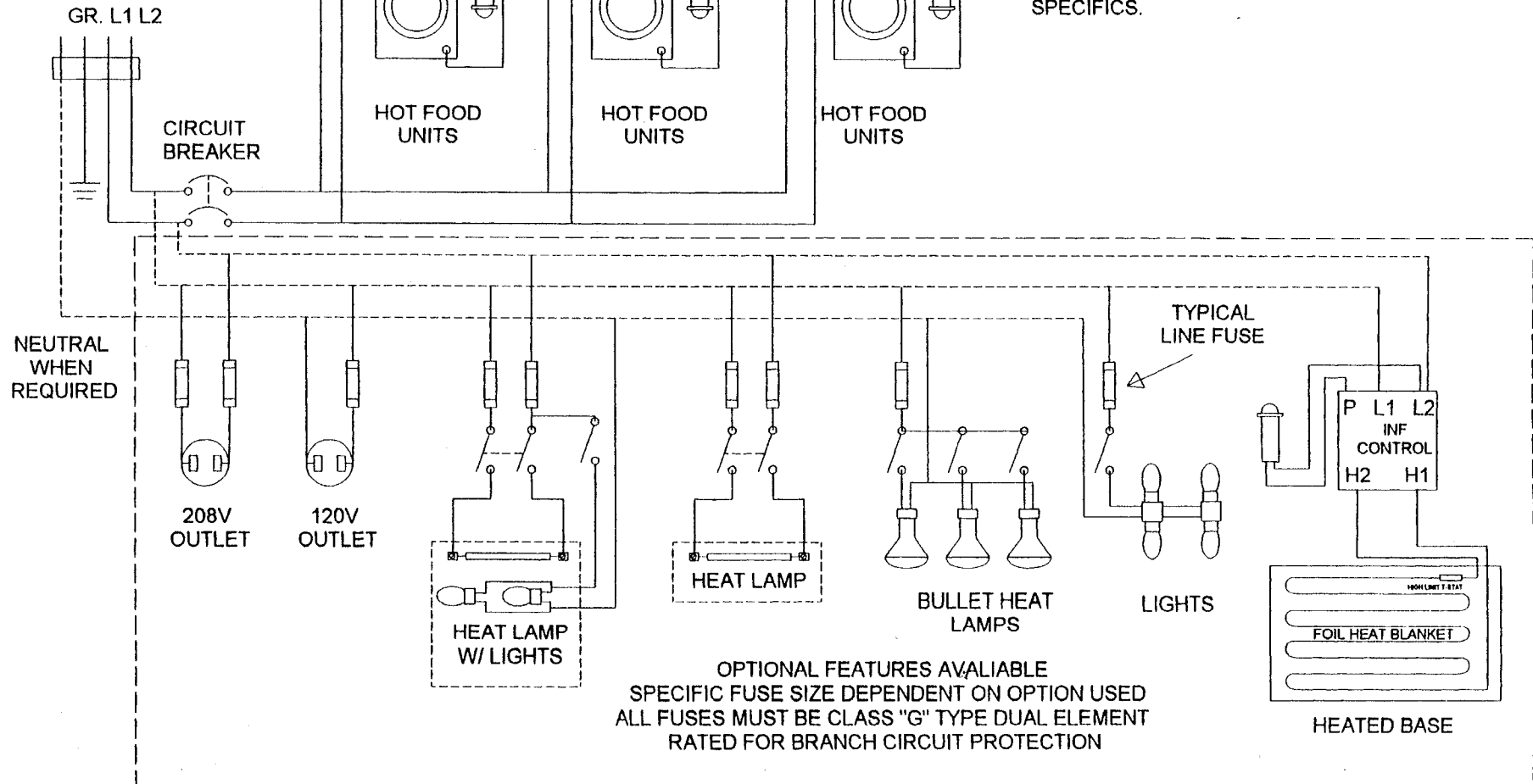

SPECIFIC PLUG WILL VARY DEPENDING UPON OPTIONS PURCHASED. CONSULT FACTORY FOR SPECIFIC PLUG AND POWER REQUIREMENTS

**NOTE! IF 190V HIGH LEG EXIST WIRE TO L2 ONLY. ALL 120V CIRCUITS WIRED TO L1 OR L3.**

THREE (3) HOT FOOD UNIT SHOWN. MAY BE PROVIDED WITH ONE (1) TO SIX (6) UNITS. STANDARD ELECTRICAL SPECIFICATION IS 208V/1000W EA OTHER VOLTAGE AND WATTAGES AVAILABLE. CONSULT FACTORY FOR SPECIFICS.

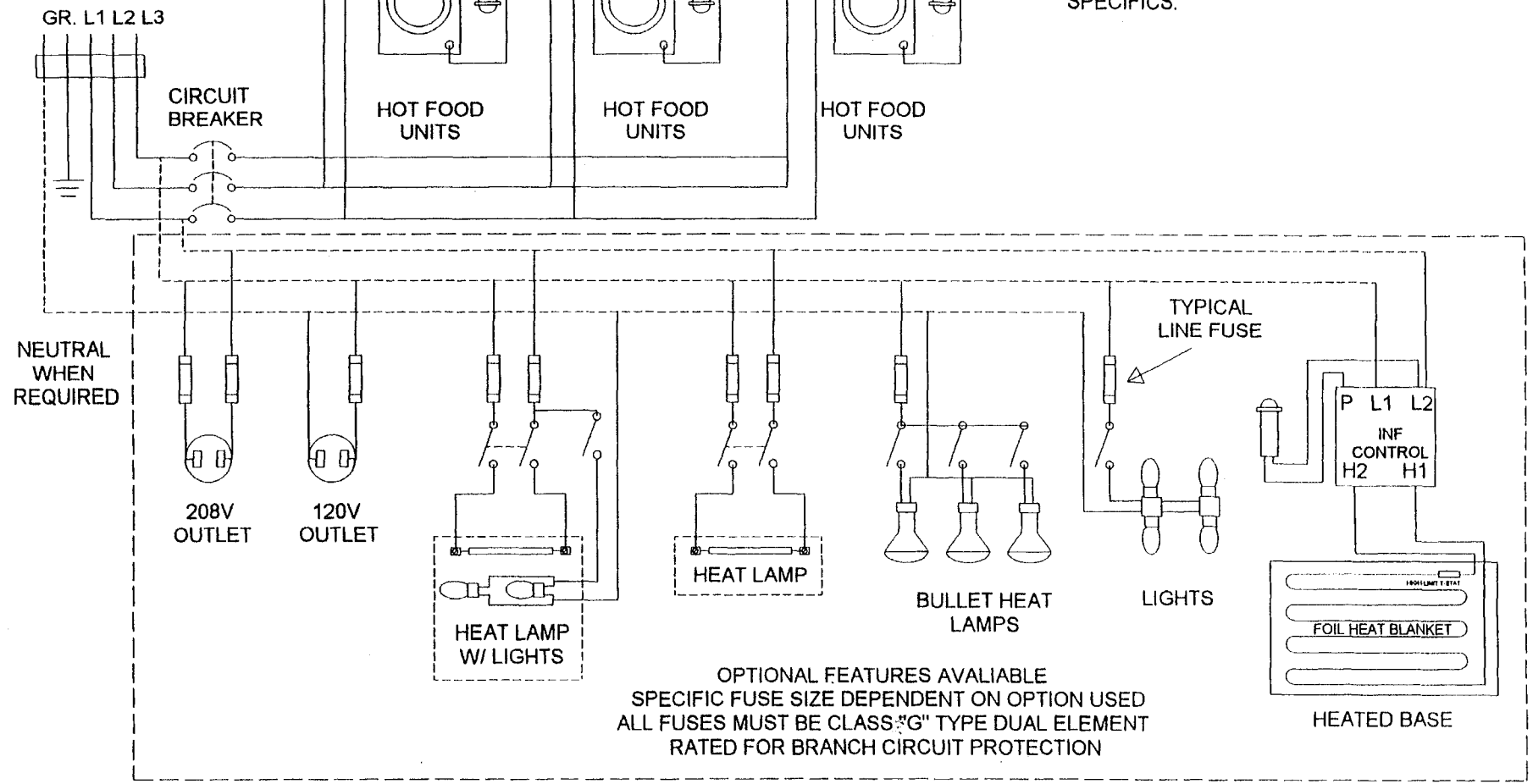

LOW TEMP INDUSTRIES INC.  
JONESBORO, GEORGIA

WIRING DIAGRAM FOR CPT SERIES  
THREE PHASE ICE COOLED/HOT TABLE

WIRING DIARGAM  
NO. LT-ENG-WD 021A

REV:

DATE 8-16-95

## TROUBLE SHOOTING SERVICE CHART

SERVICE TO BE PERFORMED BY QUALIFIED SERVICE TECHNICIAN ONLY.

### HOT FOOD SECTION

<u>COMPLAINT</u>	<u>PROBLEM</u>	<u>SOLUTION</u>
TABLE WILL NOT HEAT CONNECTIONS	1. PLUG DISCONNECTED	1. CHECK ALL ELECTRICAL
	2. LINE SWITCH OPEN	2. CLOSE SWITCH
	3. BREAKER TRIPPED	3. RESET BREAKER
	4. HEATER ELEMENT BURNED OUT OR DEFECTIVE	4. REPLACE
	5. THERMOSTAT DEFECTIVE	5. REPLACE
TABLE DOES NOT HEAT	1. LOW VOLTAGE	1. USING SUITABLE INSTRUMENT CHECK LINE VOLTAGE AND AMPERAGE. VOLTAGE MUST BE WITHIN 10 % OR NAME PLATE RATING.
	2. THERMOSTAT CALIBRATION NOT CORRECT	2. RECALIBRATE AS PER INSTRUCTIONS IN THIS MANUAL

### HOT FOOD WELL HEATING ELEMENT DATA

<u>VOLTAGE</u>	<u>WATTAGE</u>	<u>OHMS</u>	<u>AMPERAGE</u>
120	500	28.5	4.2
120	750	19.0	6.3
120	1000	14.4	8.3
208	500	86.6	2.4
208	750	57.7	3.6
<b>*208</b>	<b>*1000</b>	<b>*43.3</b>	<b>*4.8</b>
240	500	114.2	2.1
240	750	77.4	3.1
240	1000	58.5	4.1

\* STANDARD HEATING ELEMENT FOR COLORPOINT EQUIPMENT. OTHER ELEMENTS AVAILABLE UPON REQUEST.

FOIL TYPE HEATING ELEMENT FOR HEATED BASE

DOUBLE HEATED BASE  
STANDARD ELECTRICAL 208V/ 214W/ 1.03A/ 208 OHMS

SINGLE HEATED BASE  
STANDARD ELECTRICAL 208V/ 225W/ 1.08A/ 192 OHMS

# DRY/MOIST HOT FOOD UNIT EXPLODED VIEW

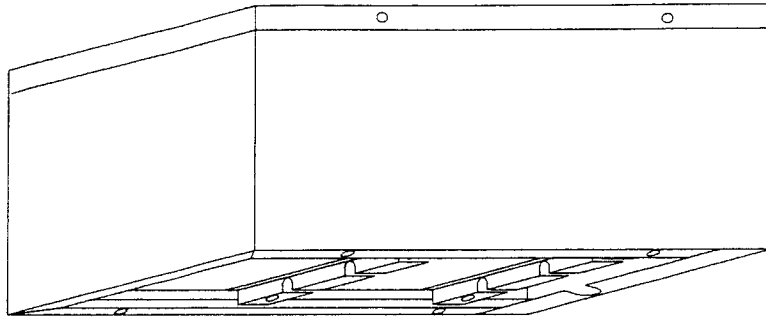

HOT FOOD WELL HOUSING WITH  
STAINLESS STEEL INNER PAN,  
GALVANIZED OUTER JACKET,  
FIBERGLASS INSULATION AND  
ELEMENT HOLDING BRACKETS.

DEFLECTOR PLATE  
WITH CAPILARY HOLDING  
CLIPS AND GROUND SCREW  
CONNECTION.

HEATING ELEMENT  
SPECIFY VOLTAGE AND PHASE  
1000W/208V STANDARD

WIRE LEADS  
HIGH TEMP TYPE TKGT  
WITH HIGH TEMP RING  
TONG END CONNECTORS

LOCK NUT

GROUND WIRE

THERMOSTAT BULB

INSULATING BUSHING  
WITH LOCKING NUT

FIBERGLASS INSULATION

BOTTOM COVER

THERMOSTAT  
2 POLE 25AMP/250V  
CONTACT RATING  
450 DEG. F. MAX

PILOT LIGHT  
250VAC RED

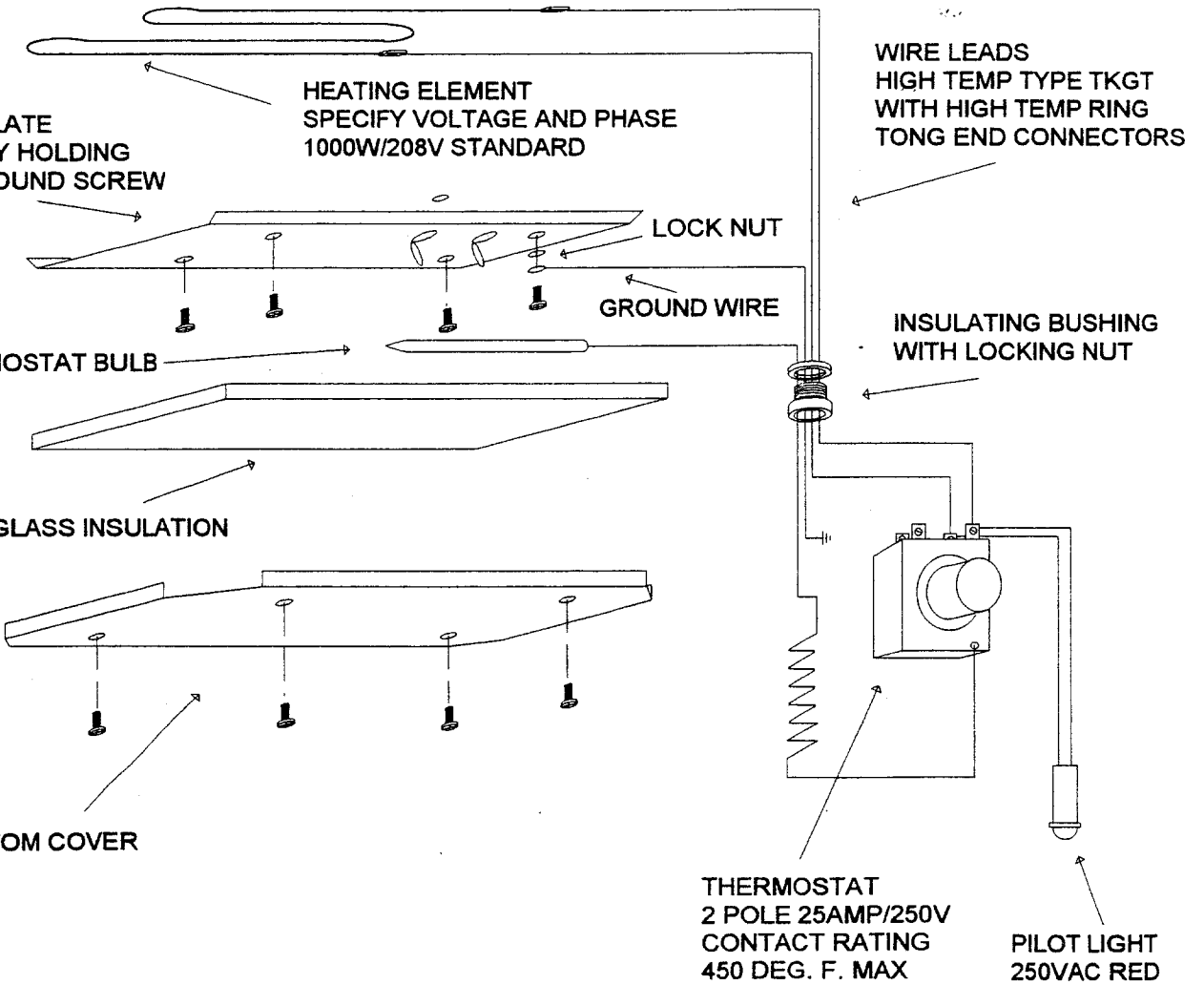

## HEATING ELEMENT REPLACEMENT

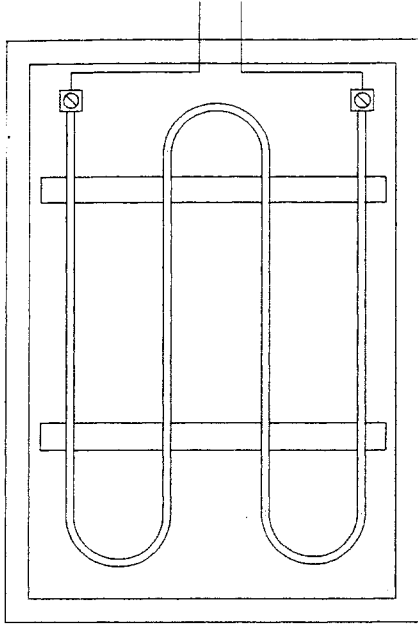

1. DISCONNECT POWER FROM UNIT
2. REMOVE THE BOTTOM COVER AND INSULATION FROM UNIT.
3. REMOVE THE BOTTOM DEFLECTOR PLATE. NOTE THE THERMOSTAT CAPILLARY MOUNTED TO THE DEFLECTOR PLATE.
4. REMOVE THE OLD HEATER FROM THE HOLDING BRACKETS.
5. REMOVE THE WIRE LEADS FROM TERMINALS.
6. REINSTALL WIRE LEADS TO NEW HEATER.
7. PLACE THE NEW ELEMENT INTO THE HOLDING BRACKETS.
8. REPLACE DEFLECTOR PLATE INSULATION AND BOTTOM COVER.

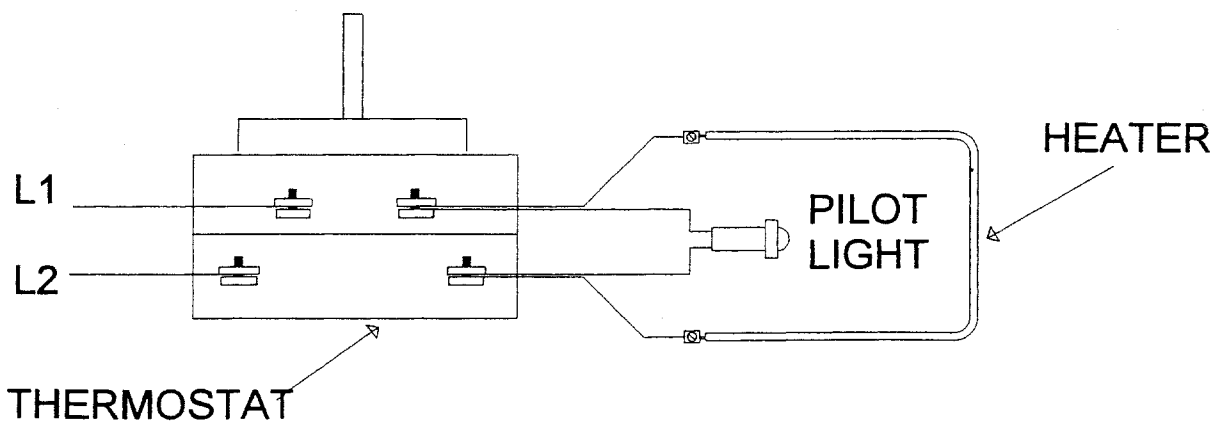

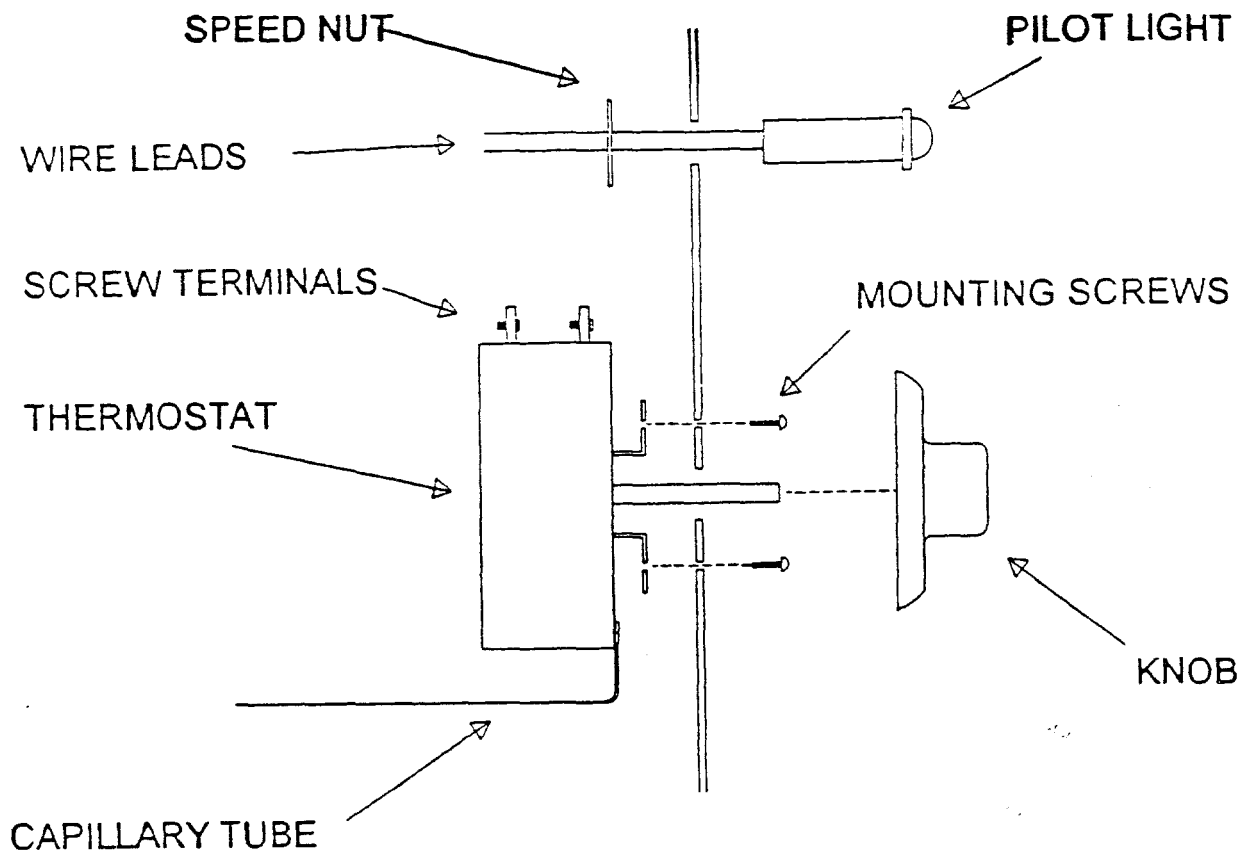

## THERMOSTAT & PILOT LIGHT MOUNTING

### TO REMOVE THERMOSTAT

1. DISCONNECT ELECTRICAL POWER
2. REMOVE THERMOSTAT MOUNTING PANEL BY REMOVING SCREWS AND PULLING PANEL FORWARD
3. REMOVE WIRE LEADS FROM THERMOSTAT SCREW TERMINALS.
4. PULL KNOB OFF AND REMOVE THE TWO MOUNTING SCREWS ON THE FRONT OF THE THERMOSTAT.
5. REMOVE THE BOTTOM COVER PLATE FROM THE HOT FOOD WELL.
6. REMOVE THE CAPILLARY BULB FROM THE DEFLECTOR PLATE.

TO REPLACE THE THERMOSTAT REVERSE THE ABOVE PROCEDURE.

### TO REMOVE PILOT LIGHT

1. DISCONNECT ELECTRICAL POWER
2. REMOVE THE THERMOSTAT MOUNTING PANEL BY REMOVING SCREWS AND PULLING PANEL FORWARD.
3. REMOVE THE WIRE LEADS FROM THERMOSTAT SCREW TERMINALS
4. REMOVE THE SPEED NUT ON BACK OF PILOT LIGHT.
5. PULL PILOT LIGHT FORWARD.

TO REPLACE THE PILOT LIGHT REVERSE THE ABOVE PROCEDURE.

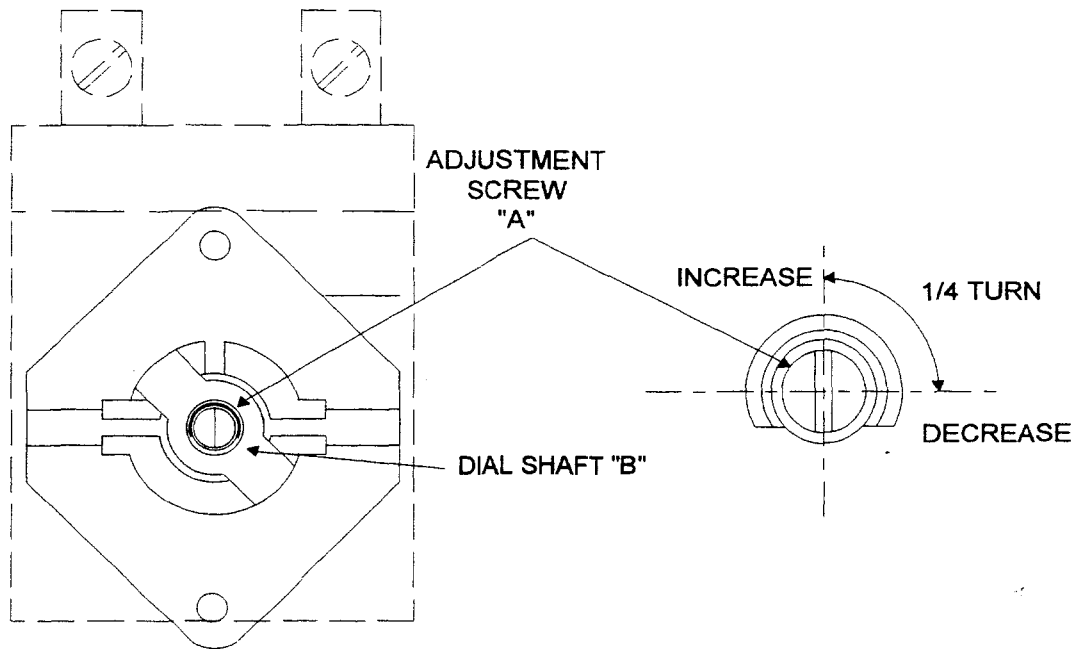

## LOW TEMP INDUSTRIES CHECKING THERMOSTAT CALIBRATION

EACH THERMOSTAT IS ADJUSTED AT THE FACTORY AND CALIBRATED ON A PRECISION INSTRUMENT TO CONTROL TEMPERATURE ACCURATELY. ADJUSTMENT OR RECALIBRATION IS NOT NEEDED UNLESS THE THERMOSTAT HAS BEEN MISHANDLED IN TRANSIT OR CHANGED OR OTHERWISE ABUSED.

### TO CHECK CALIBRATION

1. USE A POTENTIOMETER OR A GOOD GRADE THERMOMETER TO DETERMINE TEMPERATURE AT LOCATION WHERE TEMPERATURE REGULATION IS REQUIRED.
2. TURN THE DIAL OF THE THERMOSTAT TO A MEDIUM TEMPERATURE SETTING.
3. ALLOW ENOUGH TIME FOR TEMPERATURE TO STABILIZE, OR UNTIL SEVERAL TEMPERATURE READINGS ARE IDENTICAL.

### TO RECALIBRATE

1. REMOVE DIAL FROM SHAFT "B"
2. WHILE HOLDING SHAFT "B" TURN THE ADJUSTMENT SCREW "A" CLOCKWISE TO DECREASE OR COUNTER CLOCKWISE TO INCREASE. IT'S RECOMMENDED THAT ADJUSTMENTS BE NO MORE THAN 1/4 TURN AT A TIME.
3. REPLACE DIAL
4. AFTER A CALIBRATION CHANGE HAS BEEN MADE LET THE UNIT OPERATE UNTIL THE TEMPERATURE HAS STABILIZED, THEN RECHECK TO DETERMINE WHETHER OR NOT THE CALIBRATION HAS BEEN CORRECTED.

LOW TEMP INDUSTRIES  
HEATED BASE  
STANDARD ELECTRICAL 208V/440W/1PH

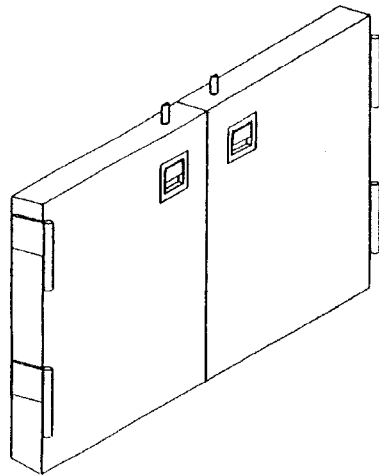

INSULATED HINGED DOORS  
WITH PADDLE LATCH AND  
LIFT-OFF HINGES

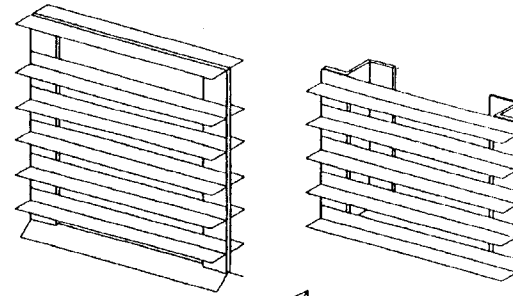

CENTER MOUNT

SIDE MOUNT

RACK SLIDES ON 2-1/2" CENTERS  
TWO (2) SIDE MOUNT WITH KEY  
HOLE SLOTS AND ONE (1) CENTER  
SLIDE IN MOUNT.

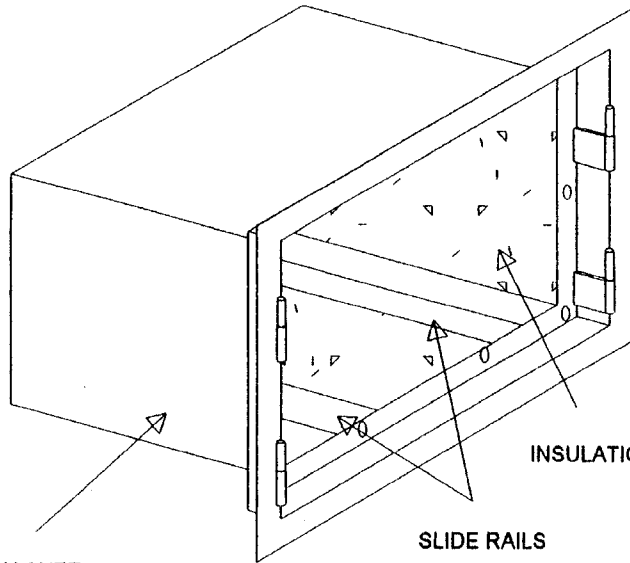

INSULATED JACKET  
MOUNTED TO BASE

INSULATION

SLIDE RAILS

WIRE LEADS

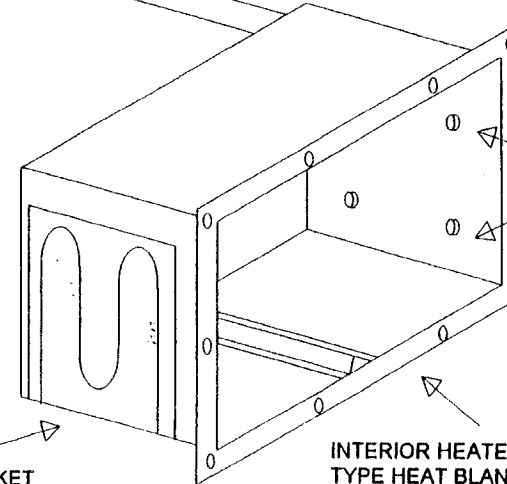

KEY HOLE STUDS

HEAT BLANKET

INTERIOR HEATED LINER WITH FOIL  
TYPE HEAT BLANKET. LINER IS MOUNTED  
INTO THE INSULATED JACKET AND SECURED  
WITH SCREWS AROUND PERIMETER FLANGE.

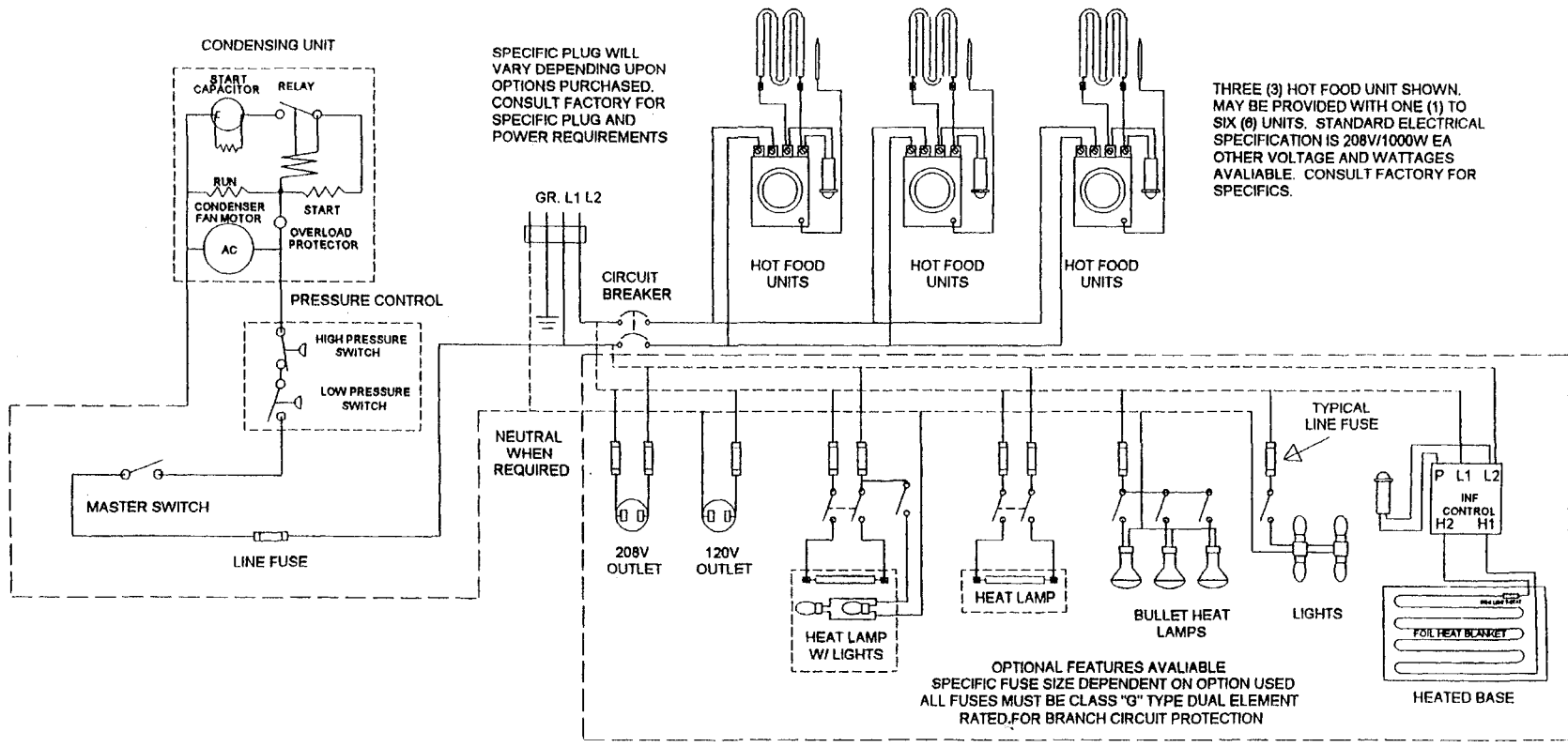

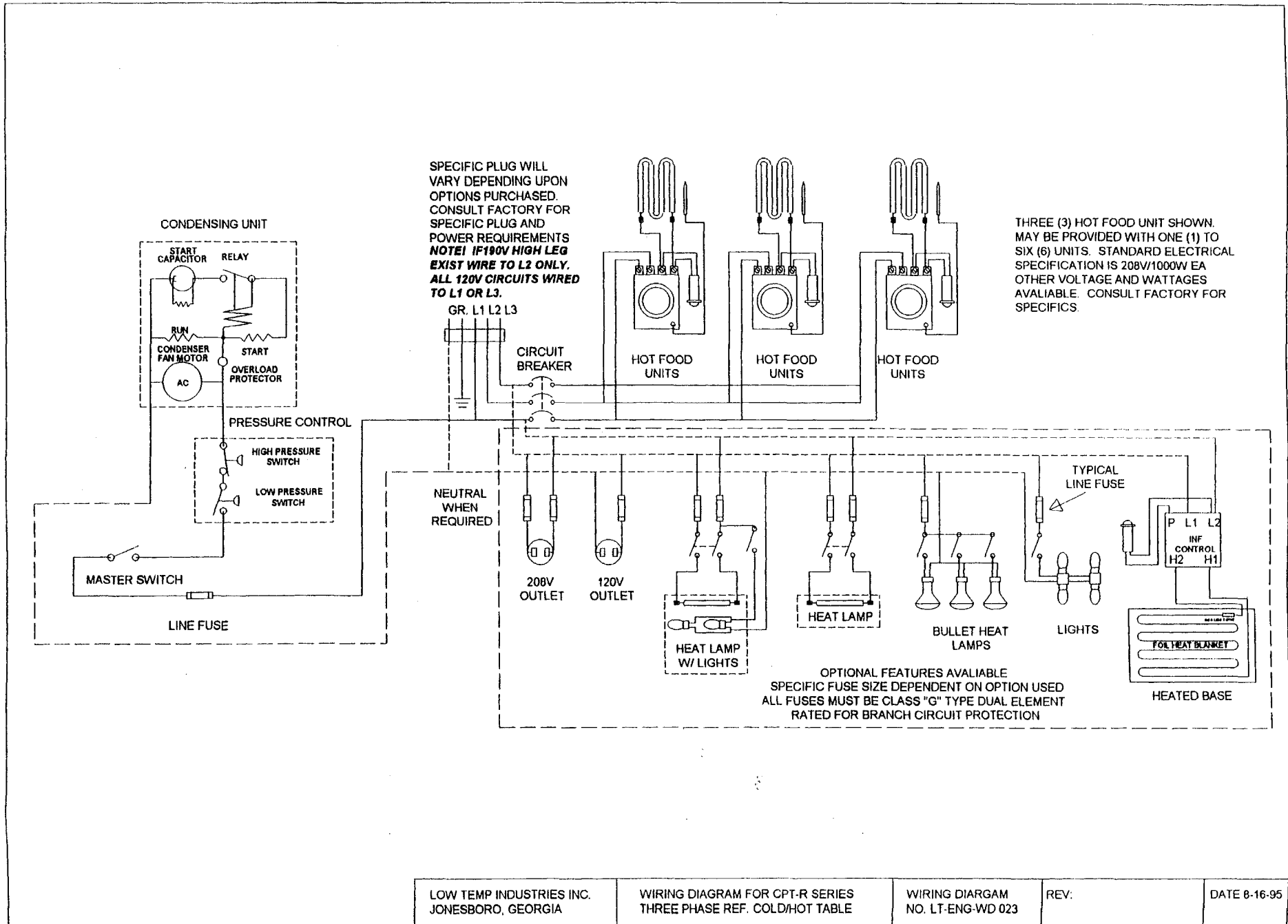

LOW TEMP INDUSTRIES INC.  
JONESBORO, GEORGIA

WIRING DIAGRAM FOR CPT-R SERIES  
THREE PHASE REF. COLD/HOT TABLE

WIRING DIAGRAM  
NO. LT-ENG-WD 023

REV:

DATE 8-16-95

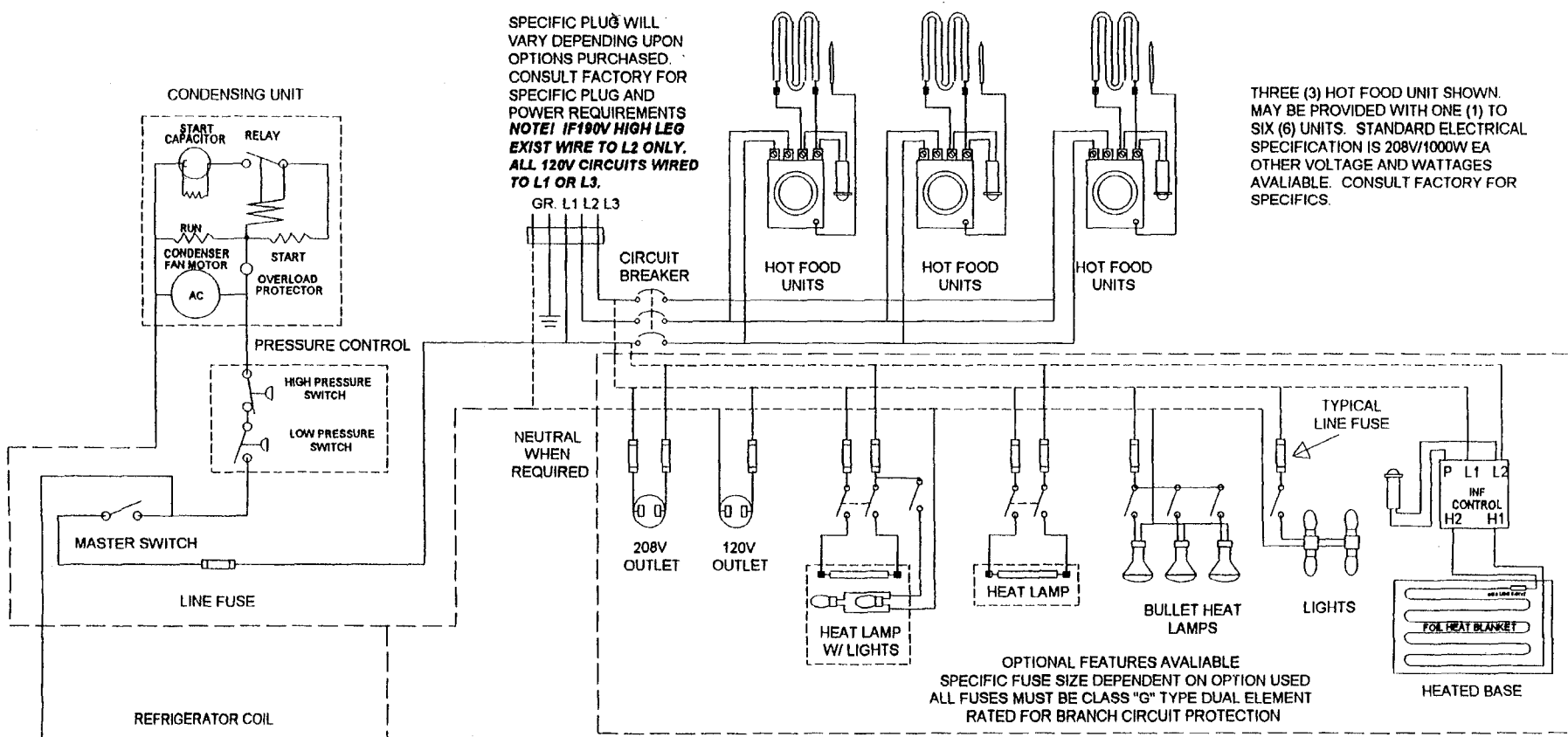

SPECIFIC PLUG WILL VARY DEPENDING UPON OPTIONS PURCHASED. CONSULT FACTORY FOR SPECIFIC PLUG AND POWER REQUIREMENTS **NOTE! IF 190V HIGH LEG EXIST WIRE TO L2 ONLY. ALL 120V CIRCUITS WIRED TO L1 OR L3.**

THREE (3) HOT FOOD UNIT SHOWN. MAY BE PROVIDED WITH ONE (1) TO SIX (6) UNITS. STANDARD ELECTRICAL SPECIFICATION IS 208V/1000W EA OTHER VOLTAGE AND WATTAGES AVAILABLE. CONSULT FACTORY FOR SPECIFICS.

OPTIONAL FEATURES AVAILABLE  
SPECIFIC FUSE SIZE DEPENDENT ON OPTION USED  
ALL FUSES MUST BE CLASS "G" TYPE DUAL ELEMENT  
RATED FOR BRANCH CIRCUIT PROTECTION

LOW TEMP INDUSTRIES INC. JONESBORO, GEORGIA	WIRING DIAGRAM FOR CPT-R SERIES THREE PHASE REF. COLD/HOT TABLE WITH REFRIGERATED BASE	WIRING DIAGRAM NO. LT-ENG-WD 024	REV:	DATE 8-16-95
--	--	-------------------------------------	------	--------------

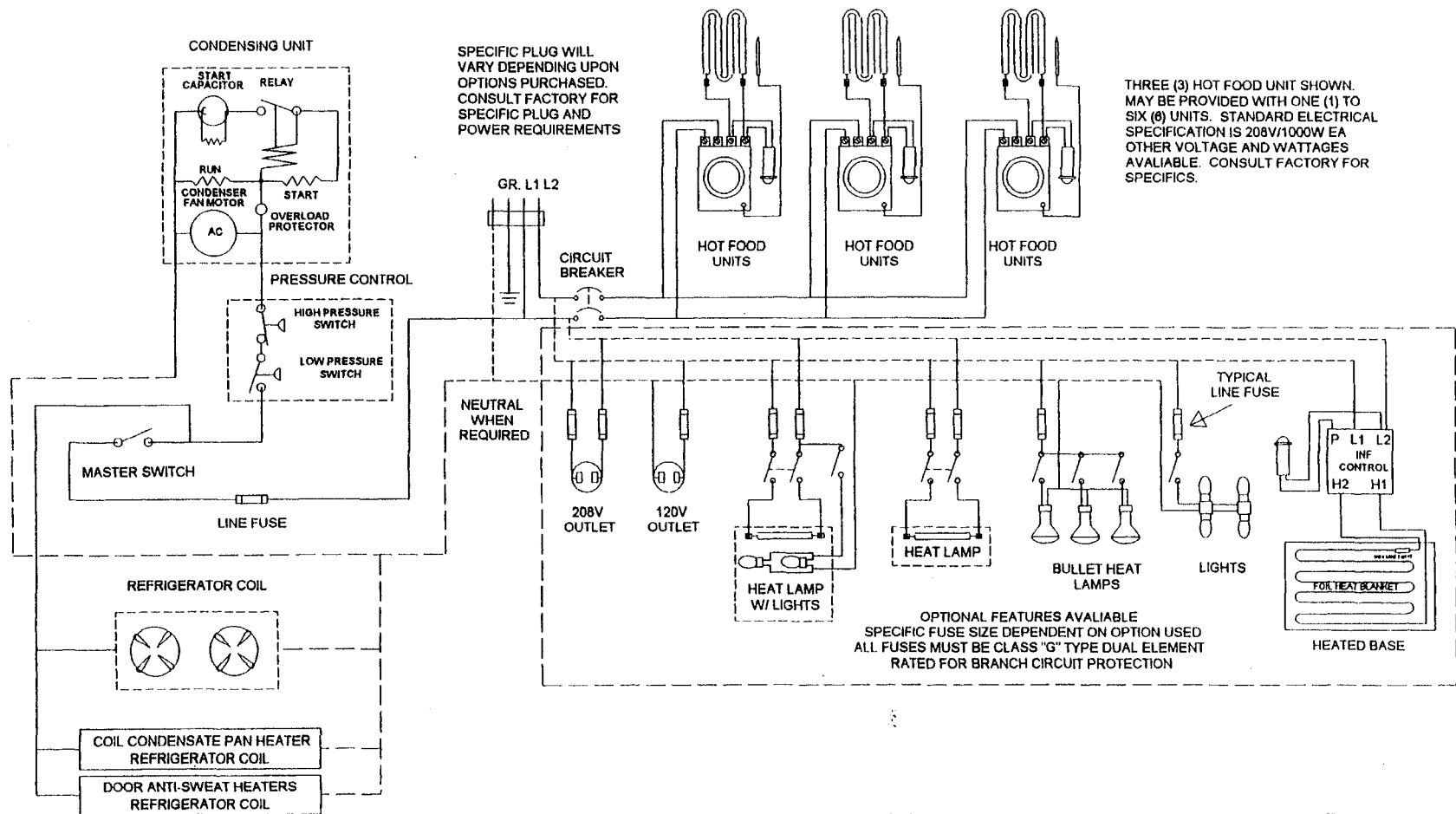

LOW TEMP INDUSTRIES INC.  
JONESBORO, GEORGIA

WIRING DIAGRAM FOR CPT-R SERIES  
SINGLE PHASE REF. COLD/HOT TABLE  
WITH REFRIGERATED BASE

WIRING DIAGRAM  
NO. LT-ENG-WD 025

REV:

DATE 8-18-95

REFRIGERATOR  
COLD WALL EVAPORATOR

EXP VALVE

SIGHT GLASS FILTER

PRESSURE CONTROL

CONDENSING UNIT

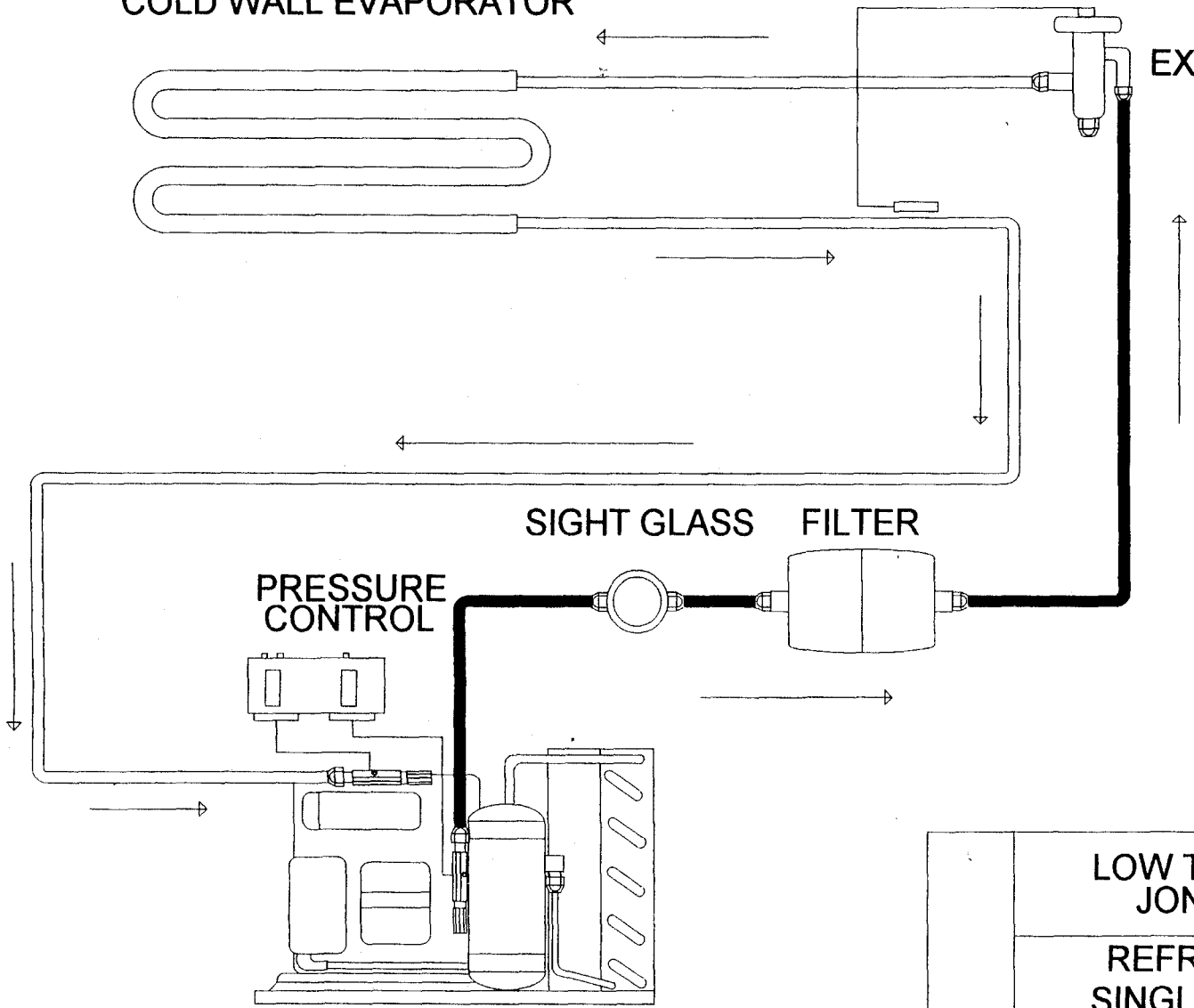

LOW TEMP INDUSTRIES INC.  
JONESBORO, GEORGIA

REFRIGERATION DIAGRAM  
SINGLE CIRCUIT COLD WALL

DATE: 4-26-95

DRAWING NO.  
LT-ENG-PD-001

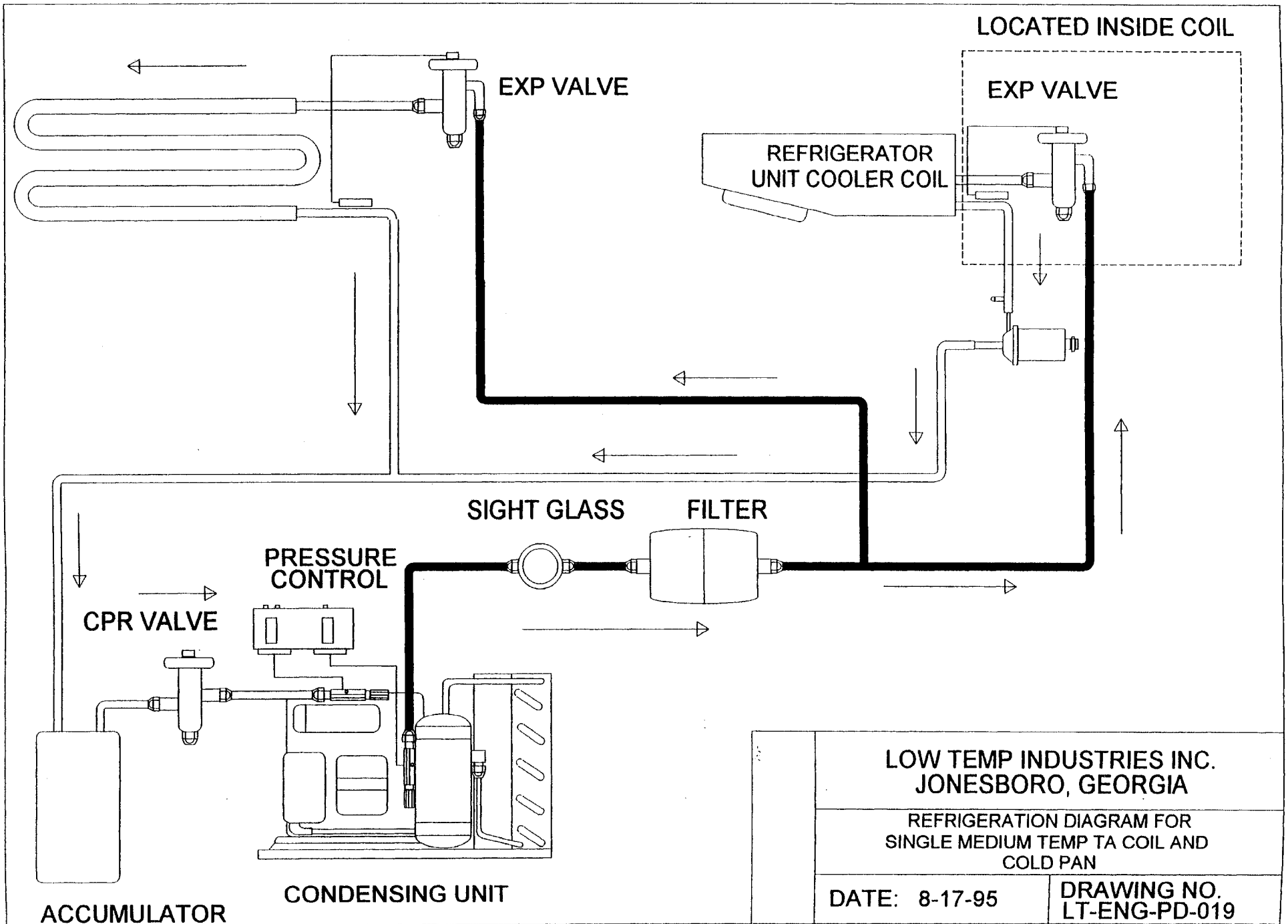

LOW TEMP INDUSTRIES INC.  
 JONESBORO, GEORGIA

REFRIGERATION DIAGRAM FOR  
 SINGLE MEDIUM TEMP TA COIL AND  
 COLD PAN

DATE: 8-17-95

DRAWING NO.  
 LT-ENG-PD-019

## REFRIGERATION SERVICE CHART

<u>COMPLAINT</u>	<u>PROBLEM</u>	<u>SOLUTION</u>
A. COMPRESSOR WILL NOT START	1. LINE DISCONNECT SWITCH OPEN 2. FUSE REMOVED OR BLOWN 3. CONTROL STUCK IN OPEN POSITION 4. CONTROL OFF DUE TO COLD LOCATION	1. CLOSE START OR DISCONNECT SWITCH 2. REPLACE FUSE 3. REPAIR OR REPLACE CONTROL 4. RELOCATE CONTROL
B. COMPRESSOR WILL NOT START, HUMS BUT TRIPS OVERLOAD PROTECTOR	1. LOW VOLTAGE TO UNIT 2. STARTING CAPACITOR DEFECTIVE 3. RELAY FAILING TO CLOSE 4. COMPRESSOR MOTOR HAS A WINDING OPEN OR SHORTED 5. INTERNAL MECHANICAL TROUBLE IN COMPRESSOR	1. CALL POWER SUPPLIER 2. REPLACE CAPACITOR 3. REPLACE RELAY 4. REPLACE COMPRESSOR 5. REPLACE COMPRESSOR
C. COMPRESSOR STARTS BUT DOES NOT SWITCH OFF OF START WINDING	1. LOW VOLTAGE TO UNIT 2. RELAY FAILING TO OPEN 3. RUN CAPACITOR DEFECTIVE 4. EXCESSIVELY HIGH DISCHARGE 5. COMPRESSOR MOTOR HAS A WINDING OPEN OR SHORTED 6. INTERNAL MECHANICAL TROUBLE IN COMPRESSOR	1. CALL POWER SUPPLIER 2. REPLACE RELAY 3. REPLACE CAPACITOR 4. CHECK DISCHARGE SHUT OVERCHARGE OR INSUFFICIENT COOLING CONDENSER. 5. REPLACE COMPRESSOR 6. REPLACE COMPRESSOR
D. COMPRESSOR STARTS AND RUNS, BUT SHORT CYCLES ON OVERLOAD PROTECTOR	1. LOW VOLTAGE TO UNIT 2. OVERLOAD PROTECTOR DEFECTIVE 3. RUN CAPACITOR DEFECTIVE 4. EXCESSIVE DISCHARGE PRESSURE 5. COMPRESSOR TOO HOT, RETURN GAS HOT 6. COMPRESSOR MOTOR HAS A WINDING SOUND	1. CALL POWER SUPPLIER 2. CHECK CURRENT, REPLACE PROTECTOR 3. REPLACE CAPACITOR 4. CHECK VENTILATION, RESTRICTIONS IN COOLING MEDIUM, RESTRICTIONS IN REFRIGERANT SYSTEM 5. CHECK REFRIGERANT CHARGE (FIX LEAK IF NECESSARY) 6. REPLACE COMPRESSOR
E. UNITS RUNS OK, BUT SHORT CYCLES ON	1. OVERLOAD PROTECTOR 2. THERMOSTAT 3. HIGH PRESSURE CUT OUT DUE TO: A. INSUFFICIENT AIR B. OVERCHARGE C. AIR IN SYSTEM 4. LOW PRESSURE CUT-OUT DUE TO:	1. SEE D-2 ABOVE 2. DIFFERENTIAL SET TOO CLOSE, WIDEN 3A. CHECK AIR SUPPLY TO CONDENSER 3B. REDUCE REFRIGERANT CHARGE 3C. PURGE

## REFRIGERANT SERVICE CHART (CONT.)

<u>COMPLAINT</u>	<u>PROBLEM</u>	<u>SOLUTION</u>
	A. UNDERCHARGED	4A. FIX LEAK AND ADD REFRIGERANT
	B. EXPANSION VALVE OUT OF ADJUSTMENT.	4B. RE-ADJUST VALVE
	C. RESTRICTION IN EXPANSION VALVE.	4C. REPLACE VALVE
F. UNIT OPERATES LONG OR CONTINUOUSLY	1. SHORTAGE OF REFRIGERANT	1. FIX LEAK, ADD CHARGE
	2. CONTROL CONTACTS STUCK OR FROZEN CLOSED	2. CLEAN CONTACTS, OR REPLACE CONTROL
	3. REFRIGERANT OR AIR CONDITIONED SPACE HAS EXCESSIVE LOAD OR POOR INSULATION	3. DETERMINE FAULT AND CORRECT
	4. EVAPORATOR COIL ICED	4. DEFROST
	5. RESTRICTION IN REFRIGERANT SYSTEM	5. DETERMINE LOCATION AND REMOVE
	6. DIRTY CONDENSER	6. CLEAN CONDENSER
	7. FILTER DIRTY	7. CLEAN OR REPLACE
G. START CAPACITOR OPEN	1. RELAY CONTACTS NOT OPENING PROPERLY	1. CLEAN CONTACTS OR REPLACE IF NECESSARY
	2. PROLONGED OPERATION ON START CYCLE DUE TO: A. LOW VOLTAGE TO UNIT B. IMPROPER RELAY	2A. CALL POWER SUPPLIER 2B. REPLACE
	3. EXCESSIVE SHORT CYCLE	3. DETERMINE REASON FOR SHORT CYCLE (SEE E. AND CORRECT)
H. RUN CAPACITOR OPEN, SHORTED OR BLOWN	1. IMPROPER CAPACITOR	1. DETERMINE CORRECT SIZE AND REPLACE
	2. EXCESSIVELY HIGH LINE VOLTAGE (100% OF RATED-MAX)	2. CALL POWER SUPPLIER
I. SPACE TEMPERATURE TOO HIGH	1. CONTROL SETTING TOO HIGH	1. RESET (CONTROL)
	2. INADEQUATE AIR CIRCULATION	2. IMPROVE AIR MOVEMENT
J. SUCTION LINE FROSTED OR SWEATING	1. EXPANSION VALVE STUCK	1. CLEAN VALVE OF FOREIGN PARTICLES REPLACE IF NECESSARY
	2. EVAPORATOR FAN NOT RUNNING	2. DETERMINE REASON AND CORRECT
	3. OVERCHARGE OF REFRIGERANT	3. CORRECT CHARGE

## **BASIC SYSTEM OPERATION (REFRIGERATION SYSTEM)**

FOLLOWING SECTION IS DESIGNED TO GIVE A BASIC WORKING KNOWLEDGE OF OUR SYSTEM. IT SHOULD NOT BE USED AS A TRAINING MANUAL FOR NON QUALIFIED REFRIGERATION TECHNICIANS.

ALL COLORPOINT REFRIGERATED EQUIPMENT EMPLOY A COMPRESSION CYCLE SYSTEM. THERE ARE TWO PRESSURES WHICH EXIST IN A COMPRESSION SYSTEM; THE EVAPORATING OR LOW PRESSURE, AND THE CONDENSING OR HIGH PRESSURE.

THE REFRIGERANT WORKS AS A TRANSPORTATION MEDIUM TO MOVE HEAT FROM THE EVAPORATOR TO THE CONDENSER WHERE IT IS GIVEN OFF TO THE AMBIENT AIR. THE CHANGE OF STATE FROM LIQUID TO VAPOR AND BACK ALLOWS THE REFRIGERANT TO ABSORB AND DISCHARGE LARGE QUANTITIES OF HEAT EFFICIENTLY.

THE BASIC SYSTEM OPERATES AS FOLLOWS:

HIGH PRESSURE LIQUID REFRIGERANT IS FED FROM THE RECEIVER THROUGH THE LIQUID LINE AND THROUGH THE FILTER DRIER AND SIGHT GLASS TO THE EXPANSION VALVE WHICH WORKS AS A METERING DEVICE SEPARATING THE HIGH PRESSURE SIDE OF THE SYSTEM FROM THE LOW PRESSURE EVAPORATOR.

THE THERMOSTATIC EXPANSION VALVE CONTROLS THE FEED OF LIQUID REFRIGERANT TO THE EVAPORATOR, AND BY MEANS OF AN ORIFICE REDUCES THE PRESSURE OF THE REFRIGERANT TO THE EVAPORATING OR LOW PRESSURE SIDE.

THE REDUCTION OF PRESSURE ON THE LIQUID REFRIGERANT CAUSES IT TO BOIL OR VAPORIZE UNTIL THE REFRIGERANT IS AT THE SATURATED TEMPERATURE CORRESPONDING TO ITS PRESSURE. AS THE LOW TEMPERATURE REFRIGERANT PASSES THROUGH THE EVAPORATOR COIL, HEAT FLOWS THROUGH THE WALLS OF THE EVAPORATOR TUBING TO THE REFRIGERANT, CAUSING THE BOILING ACTION TO CONTINUE UNTIL THE REFRIGERANT IS COMPLETELY VAPORIZED.

THE EXPANSION VALVE REGULATES THE FLOW THROUGH THE EVAPORATOR AS NECESSARY TO MAINTAIN A PRESET TEMPERATURE DIFFERENCE OR SUPER HEAT BETWEEN THE EVAPORATING REFRIGERANT AND VAPOR LEAVING THE EVAPORATOR. AS THE TEMPERATURE OF THE GAS LEAVING THE EVAPORATOR VARIES THE EXPANSION VALVE POWER ELEMENT BULB SENSES ITS TEMPERATURE, AND ACTS TO MODULATE THE FEED THROUGH THE EXPANSION VALVE AS REQUIRED.

THE REFRIGERANT VAPOR LEAVING THE EVAPORATOR TRAVELS THROUGH THE SUCTION LINE TO THE COMPRESSOR INLET. THE COMPRESSOR TAKES THE LOW PRESSURE VAPOR AND COMPRESSES IT, INCREASING BOTH THE PRESSURE AND THE TEMPERATURE. THE HOT, HIGH PRESSURE GAS IS FORCED OUT THE COMPRESSOR DISCHARGE VALVE AND INTO THE CONDENSER.

AS THE HIGH PRESSURE GAS PASSES THROUGH THE CONDENSER, IT IS COOLED BY A FAN BLOWING OVER A FIN-TYPE CONDENSER SURFACE. AS THE TEMPERATURE OF THE REFRIGERANT VAPOR REACHES THE SATURATION TEMPERATURE CORRESPONDING TO THE HIGH PRESSURE IN THE CONDENSER, THE VAPOR CONDENSES INTO A LIQUID AND FLOWS BACK INTO THE RECEIVER TO REPEAT THE CYCLE.

THE REFRIGERATION PROCESS IS CONTINUED AS LONG AS THE COMPRESSOR OPERATES. THE COMPRESSOR OPERATION IS CONTROLLED BY A LOW PRESSURE CONTROL. WHEN THE REFRIGERANT VAPOR ENTERING THE SUCTION SIDE OF THE COMPRESSOR REACHES A PRESET VALUE ON THE CONTROL, IT WILL OPEN A SET OF CONTACTS AND SHUT THE COMPRESSOR OFF.

THE LOW PRESSURE IS SET BY A "CUT-IN" AND A "DIFFERENTIAL" SETTING. THE "CUT-IN" IS THE PRESSURE AT WHICH YOU WANT THE COMPRESSOR TO START. THIS PRESSURE CORRESPONDS

TO THE TEMPERATURE OF THE EVAPORATOR SURFACE WHICH MUST BE MAINTAINED. NOTE THAT AS A RULE OF THUMB ALL COLORPOINT UNITS HAVE APPROXIMATELY A 10 DEGREE FAHRENHEIT TEMPERATURE DIFFERENCE. BETWEEN THE EVAPORATOR COILS AND THE WORKING SURFACE. SO THE PRESSURE CORRESPONDING TO THE "CUT-IN" SHOULD BE 10 DEGREES LESS THAT THE OPERATING TEMPERATURE OF THE REFRIGERATED SURFACE. TO CUT THE UNIT OFF THE "DIFFERENTIAL" SETTING IS USED. FIRST CHOOSE THE TEMPERATURE SETTING AT WHICH YOU WANT THE UNIT TO CUT OFF. THEN SUBTRACT FROM THE "CUT-IN" SETTING. THAT IS THE VALUE OF THE DIFFERENTIAL.

**REPLACEMENT PARTS LIST**  
**MODEL CPT SERIES**

ITEM NO.	DESCRIPTION	STOCK NO.	MFG. NO.	MANUFACTURER
1	HOT FOOD UNIT (1000W/208V COMPLETE UNIT WITH HEATING ELEMENT AND T-STAT READY TO INSTALL)	LT-1008	LT-1008	LOW TEMP
1A	HOT FOOD UNIT W/ DRAIN (1000W/208V COMPLETE UNIT WITH HEATING ELEMENT AND T-STAT READY TO INSTALL. STANDARD DRAIN 3/4" FPT)	LT-1008D	LT-1008D	LOW TEMP
2	HEATING ELEMENT 1000W/208V	195000	319871242007	CHROMALOX
3	THERMOSTAT	195400	KA-601-72	ROBERTSHAW
4	PILOT LIGHT	358000	515-5CL	JEMCO

**NOTE! FOR PART NUMBERS ON HOT FOOD WELLS OTHER THAN THOSE LISTED ABOVE CONTACT THE FACTORY.**

5	CASTERS 4" W/ BRAKES	130810	2-4056-43	JARVIS AND JARVIS
6	CIRCUIT BREAKERS			
	1 POLE 15 AMP	332100	QOU-115	SQUARE "D"
	1 POLE 20 AMP	332110	QOU-120	SQUARE "D"
	1 POLE 30 AMP	332120	QOU-130	SQUARE "D"
	2 POLE 15 AMP	332200	QOU-215	SQUARE "D"
	2 POLE 20 AMP	332210	QOU-220	SQUARE "D"
	2 POLE 30 AMP	332220	QOU-230	SQUARE "D"
	2 POLE 40 AMP	332230	QOU-240	SQUARE "D"
	3 POLE 15 AMP	332300	QOU-315	SQUARE "D"
	3 POLE 20 AMP	332310	QOU-320	SQUARE "D"
	3 POLE 30 AMP	332320	QOU-330	SQUARE "D"

**CHECK YOUR UNIT FOR SPECIFIC CIRCUIT BREAKER NEEDED.**

**ADDITIONAL OPTIONS AVAILABLE**

7	SWITCH SINGLE POLE (BALL BAT LIGHT SWITCH)	335900	90-0001	McGILL
8	SWITCH DOUBLE POLE (BALL BAT HEAT LAMP SWITCH)	335920	0121-0001	McGILL
9	TUNGSTEN SWITCH (PADDLE SWITCH USED WITH BULLET TYPE HEAT LAMPS)	335911	TA115PWBXGC1	CARLING
10	FLUORESCENT FIXTURE	360700	M15L	NULITE
11	FLUORESCENT BULB	358100	F15T8/CW	SYLVANIA
12	BULB SLEEVE & CAP	493510	18" T8	TRU-TEST

**REPLACEMENT PARTS LIST**  
**MODEL CPT**  
**ADDITIONAL OPTIONS**  
**(CONT.)**

ITEM NO.	DESCRIPTION	STOCK NO.	MFG. NO.	MANUFACTURER
13	SINGLE PORCELAIN SOCKET (USED WITH BULLET TYPE HEAT LAMP OR INCANDESCENT BULBS NOT IN HEAT LAMPS)	360610	10035-000	LEVITON
14	DOUBLE PORCELAIN SOCKET (USED WITH INCANDESCENT BULB NOT IN HEAT LAMPS)	533800	4010	LEVITON
15	BULLET HEAT LAMPS (250 W / 120 V / CLEAR WITH TOUGH SKIN COATING)	357800	250R40/1CVG	GENERAL ELECTRIC
16	INCANDESCENT BULBS (40 W / 120 V APPLIANCE BULBS WITH TOUGH SKIN COATING)	494300	R79-0040	COMPONENT HARDWARE
17	FUSE HOLDER	358210	571027	LITTLE FUSE
18	STOCK FUSES			
	1A	513800	SLC-1 CLASS G	LITTLE FUSE
	2A	513810	SLC-2 CLASS G	LITTLE FUSE
	4A	513820	SLC-4 CLASS G	LITTLE FUSE
	5A	513830	SLC-5 CLASS G	LITTLE FUSE
	6A	513840	SLC-6 CLASS G	LITTLE FUSE
	8A	513850	SLC-8 CLASS G	LITTLE FUSE
	10A	513860	SLC-10 CLASS G	LITTLE FUSE
	15A	513870	SLC-15 CLASS G	LITTLE FUSE
	20A	513880	SLC-20 CLASS G	LITTLE FUSE

**NOTE! REPLACE WITH SAME TYPE AND AMPERAGE FUSE. CHECK YOUR UNIT FOR THE SPECIFIC FUSE USED.**

19	INFINITE CONTROL (USED WITH HEATED BASE)	190600	INF-240-3	ROBERTSHAW
20	THERMOMETER (USED WITH HEATED BASE)	500040	2215-01-4	COOPER

FOR REPLACEMENT HEATING SYSTEMS FOR HEATED BASES, SPECIFY SINGLE OR DOUBLE BASE. STANDARD VOLTAGE IS 208V.

FOR PARTS CONCERNING CALROD TYPE HEAT LAMPS STRIPS SUPPLIED WITH THIS SYSTEM CONTACT YOUR FACTORY REPRESENTATIVE.

**REPLACEMENT PARTS LIST**  
**MODEL CPT-R**  
**(THIS SYSTEM USES R-22 REFRIGERANT)**

ITEM NO.	DESCRIPTION	STOCK NO.	MFG. NO.	MANUFACTURER
21	CONDENSING UNIT	311931	MSYH-0025-IAA	COPELAND
22	PRESSURE CONTROL	280610	012-4834-000	RANCO
23	FILTER / DRIER	282300	C-052-T-HH	SPORLAN
24	SIGHT GLASS	282400	SA-12FM	SPORLAN
25	EXPANSION VALVE	282570	SQ-O-(1/3T)-VC-5'	SPORLAN
26	TOGGLE SWITCH	335900	TA205-PWB	CARLING
27	CASTERS	130810	2-4056-43	JARVIS AND JARVIS
28	AXIAL FAN	312400	028021	CON-AIR ROTRON

**COMPONENTS WITH REFRIGERATED BASE OPTION**

29	UNIT COOLER	312220	TA-0100C	BOHN
30	THERMOMETER	500031	65356X	CLIFTON
31	EVAP. PRES. REG	282010	139-001	EATON
32	EXPANSION VALVE	282570	SQ-O-(1/3T)-VC-5'	SPORLAN
33	ANTI-CONDENSATE PAN	237900	T12-5000	COMPONENT HARDWARE
34	DOOR GASKET	493440	16" X 16"	JEANS
35	DR HINGE TOP L.H.	158110	1522 L00004	KASON
35A	DR HINGE BTM. L.H.	158120	1521 L00004	KASON
36	DR HINGE TOP R.H.	158130	1522 R00008	KASON
36A	DR HINGE BTM R.H.	158140	1521 R00008	KASON

# **ONE YEAR WARRANTY**

ALL COLORPOINT FOOD SERVICE EQUIPMENT IS FULLY WARRANTED BY THE MANUFACTURER AGAINST DEFECTS IN MATERIALS OR WORKMANSHIP FOR A PERIOD OF ONE (1) YEAR FROM THE DATE OF PURCHASE BY THE ORIGINAL USER AND ONLY TO THE ORIGINAL PURCHASER PROVIDED IT IS INSTALLED AND OPERATED IN ACCORDANCE WITH THE INSTRUCTIONS SUPPLIED WITH THE UNIT. ALSO, IT MUST NOT BE MISUSED, ALTERED OR NEGLECTED AND USED ONLY ON CIRCUITS AND VOLTAGES REQUIRED FOR THAT UNIT.

OUR OBLIGATION UNDER THIS WARRANTY SHALL BE LIMITED TO ONE OF THE FOLLOWING PROCEDURES. SELECTION OF A PROCEDURE SHALL BE AT THE SOLE DISCRETION OF LOW TEMP INDUSTRIES INC.

- A. REPLACEMENT OF DEFECTIVE PARTS, SHIPPED F.O.B. FACTORY, IN EXCHANGE FOR THE RETURNED DEFECTIVE PART, SHIPPED PREPAID FREIGHT.
- B. FREE REPLACEMENT OF DEFECTIVE PART, SHIPPED F.O.B. FACTORY.
- C. DEFECTIVE PART SHIPPED PREPAID FREIGHT TO FACTORY, REPAIRED AND RETURNED, SHIPPED F.O.B. . FACTORY.
- D. ALL LABOR COSTS SHALL BE COVERED FOR A PERIOD OF 1 YEAR FROM THE DATE OF PURCHASE.

LOW TEMP INDUSTRIES INC. SHALL NOT BE RESPONSIBLE FOR ANY DAMAGE CAUSED BY FIRE, FLOOD, WINDSTORM, OR ANY OTHER ACT OF GOD; WAR, WHETHER DECLARED OR UNDECLARED NOR SHALL WE BE RESPONSIBLE FOR THE LOSS OF FOOD OR OTHER PRODUCTS DUE TO POWER OR MECHANICAL FAILURE. THIS WARRANTY SHALL NOT COVER ANY DAMAGE CAUSED DURING SHIPMENT WHICH SHOULD BE REPORTED TO THE DELIVERING CARRIER.

## **COLORPOINT FIBERGLASS FOOD SERVICE EQUIPMENT**

**A DIVISION OF LOW TEMP INDUSTRIES INC.  
9192 TARA BOULEVARD  
JONESBORO, GEORGIA 30236  
(770) 478-8803**

# **FIVE YEAR COMPRESSOR WARRANTY**

ALL COLORPOINT MECHANICALLY REFRIGERATED EQUIPMENT CARRIES AN EXTENDED COMPRESSOR WARRANTY BY LOW TEMP INDUSTRIES, INC.

THIS EXTENDED WARRANTY BEGINS ON THE EXPIRATION DATE OF THE ONE (1) YEAR WARRANTY BY THE COMPRESSOR MANUFACTURER AND WARRANTS THE COMPRESSOR AGAINST DEFECTS IN MATERIALS OR WORKMANSHIP FOR A PERIOD OF FOUR (4) YEARS TO THE ORIGINAL USER AND ONLY TO THE ORIGINAL PURCHASER PROVIDED IT IS INSTALLED AND OPERATED IN ACCORDANCE WITH THE INSTRUCTIONS SUPPLIED WITH THE UNIT.

THIS WARRANTY COVERS ONLY THE COMPRESSOR AND DOES NOT INCLUDE ANY RETURN SHIPPING CHARGES, OTHER TRANSPORTATION CHARGES, ANY EXTERNAL PARTS OR ELECTRICAL COMPONENTS, LABOR, REFRIGERANTS OR TAXES.

WARRANTY SHALL BE VOID IF THE UNIT HAS BEEN MISUSED, ALTERED OR NEGLECTED. THE SERIAL NUMBER SHALL NOT BE REMOVED OR DEFACED, AND THE UNIT SHALL BE USED ONLY ON CIRCUITS AND VOLTAGES REQUIRED FOR THAT UNIT.

OUR OBLIGATION UNDER THIS EXTENDED WARRANTY SHALL BE LIMITED TO ONE OF THE FOLLOWING PROCEDURES:

A. REPLACEMENT OF DEFECTIVE COMPRESSOR, SHIPPED FREIGHT PREPAID, IN EXCHANGE FOR THE RETURNED DEFECTIVE COMPRESSOR, SHIPPED PREPAID FREIGHT.

B. REPLACEMENT OF DEFECTIVE COMPRESSOR AT A LOCAL REFRIGERATION SUPPLY HOUSE, IN EXCHANGE FOR THE DEFECTIVE COMPRESSOR.

NO REPLACEMENT OF COMPRESSOR(S) WILL BE AUTHORIZED UNDER EXTENDED WARRANTY WITHOUT ACCURATE VERIFICATION OF SERIAL NUMBER(S) OF DEFECTIVE COMPRESSOR(S).

LOW TEMP INDUSTRIES, INC. MUST BE NOTIFIED PRIOR TO COMPRESSOR REPLACEMENT FOR A WARRANTY AUTHORIZATION NUMBER. ANY REQUESTS FOR WARRANTY CLAIMS WITHOUT A WARRANTY AUTHORIZATION NUMBER, WILL NOT BE HONORED.

THIS EXTENDED WARRANTY DOES NOT COVER ANY DAMAGES CAUSED BY FIRE, FLOOD, WINDSTORM, OR ANY OTHER ACT OF GOD; WAR, WHETHER DECLARED OR UNDECLARED NOR SHALL BE RESPONSIBLE FOR THE LOSS OF FOOD OR OTHER PRODUCTS DUE TO POWER OR MECHANICAL FAILURE.

## **COLORPOINT FIBERGLASS FOOD SERVICE EQUIPMENT**

**A DIVISION OF LOW TEMP INDUSTRIES INC.**

**9192 TARA BOULEVARD  
JONESBORO, GEORGIA 30236  
(770) 478-8803**