



Changing
how food is served.

OPERATION/MAINTENANCE MANUAL



SPC-MX

MX SERIES
COLD PAN SYSTEM

CUSTOM FABRICATORS OF FOODSERVICE EQUIPMENT

1947 Bill Casey Parkway • Jonesboro, GA 30236
Tel: 1 (888) 584-2722 • Fax: 1 (770)-471-3715
www.lowtempind.com

Table of Contents

INSPECTION	3
SAFETY PRECAUTIONS.....	3
MODEL NOMENCLATURE :.....	5
INSTALLATION INSTRUCTIONS	6
OPERATING INSTRUCTIONS	8
START UP	8
OPERATION	8
CLEANING INSTRUCTIONS.....	10
PREVENTATIVE MAINTENANCE.....	11
TROUBLESHOOTING.....	12
REPLACEMENT PARTS	13
DIAGRAMS	14
WARRANTY	19

INSPECTION

Upon receipt, the crate should be inspected for visual damage. Any damage should be reported immediately to the carrier.

SAFETY PRECAUTIONS

This manual includes safety and operating instructions for MX series cold pan system. LTI recommends reading all safety precautions and statements to ensure safe operation before installing and operating. Below are the precautions that are explained in more detail. Please read carefully.



DANGER

Danger warns of imminent hazard which will result in serious injury or death.



WARNING

Warning indicates the presence of a potential hazard or unsafe practice that will or can cause severe personal injury or death.



CAUTION

Caution indicate the presence of a hazard or unsafe practice that will or can cause minor or moderate personal injury if the caution is ignored.

NOTICE:

Used to note information that is important but not hazard-related.



WARNING

ELECTRIC SHOCK HAZARD

- Unit must be installed by a qualified electrician. Installation must conform to all local electrical codes. In the absence of local codes, use the latest version of the National Electrical Code.
- Unit should be safely and adequately grounded in accordance to local codes, or in the absence of local codes, the most up to date version of the National Electrical Code ANSI/NFPA70, to protect the user from electrical shock.
- The unit requires a grounded system and a dedicated circuit.
- The unit must be serviced by qualified personnel only. Service by unqualified personnel may lead to electric shock or burn.
- Control panel must be mounted on a vertical surface/wall and installed in the vertical position. Mounting control panel in the horizontal position may result in collection of liquids and lead to electrical shock.
- Turn OFF power, unplug power cord/turn off power at circuit breaker, and allow unit to cool if needed to before performing any cleaning, adjustments, or maintenance.
- Do not use flammable cleaning solutions to clean this unit.

NOTICE:

- Units are voltage specific. Refer to specifications label for electrical requirements before installation.
- Use non-abrasive cleaners and cloths only. Abrasive cleaners and cloths could scratch finish of unit, marring its appearance and making it susceptible to soil accumulation.
- Do not use steel wool for cleaning.
- Do not use harsh chemicals such as bleach, cleaners containing bleach, or oven cleaners to clean this unit.

MODEL NOMENCLATURE :

Example: SPC – MX – ME – 12 – 04 – RBS – 74
 A B C D E F G

A – COUNTER STYLE

SPC – SPECLINE

B – MX = RECESSED COLD PAN

C – BODY STYLE

MF- MOLDED FIBERGLASS

FP – FIBERGLASS PANEL

LP – LAMINATE PLASTIC

LSS – LAMINATE OVER STAINLESS

SS – STAINLESS STEEL

D – WIDTH OF PAN

20 – STANDARD 20"

12 – SLIM 12"

E – NUMBER OF PANS THE UNIT HOLDS

F – SUFFIX to indicate another refrigerated section in addition to the MX cold well.

GFTTxx = glass frost top tier, followed by nominal length in inches

QSGTxx = Quick-switch glass top tier, followed by nominal length in inches

RBS = refrigerated base single

RBD = refrigerated base double

SFTxx = stainless steel frost top tier, followed by nominal length in inches

G – COUNTER LENGTH

SPC LENGTHS SPECIFIED BY ORDER

INSTALLATION INSTRUCTIONS

LTI MX Series is a refrigeration system designed for short term display and dispensing of food and deserts. This unit is designed to maintain a product temperature at a maximum of 40° F for periods up to four (4) hours. These units are dependent upon the ambient temperature in which they are installed and the product temperature when it is placed in the units. The product should be carefully monitored and rotated as necessary to meet local health requirements.

When installed adequate air flow must be provided to ensure proper operation. Thru air flow is required but if not, exhaust fans should be used to ensure adequate heat exhaust. Connect the unit into the proper grounded electrical service. Refer to unit's electrical data tag for correct electrical service requirements. The unit is now ready for operation.

Refer to figure for dimensions and overall details.

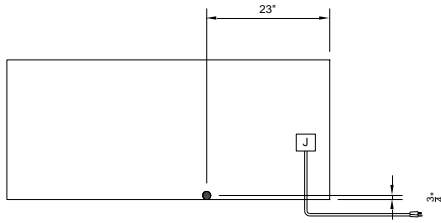

MECHANICAL VIEW

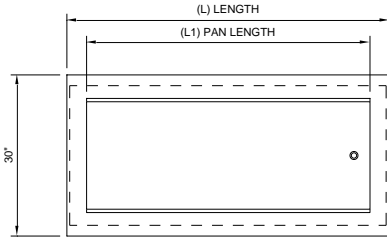

PLAN VIEW

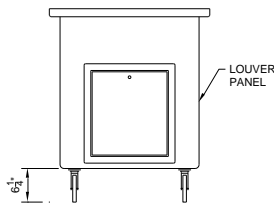

END VIEW

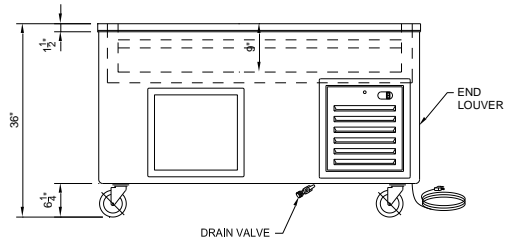

OPERATOR VIEW

Model # W/ OR W/O SLOPE (*SP3*)	Pans Capacity	Unit Length L	Cold Pan Length L1	Comp.	Fans	Volts/ Phase	Amps (120V)	NEMA Plug	Approx. Ship Weight
SPC-MX-20-2-36	2	36 3/8"	25"	1/3	1	120V/1	5.8	5-15	400 lbs.
SPC-MX-20-3-50	3	50 3/8"	38"	1/3	1	120V/1	5.8	5-15	450 lbs.
SPC-MX-20-4-60	4	60 3/8"	51"	1/3	2	120V/1	5.8	5-15	580 lbs.
SPC-MX-20-4-66	4	66 3/8"	51"	1/3	2	120V/1	5.8	5-15	600 lbs.
SPC-MX-20-5-74	5	74 3/8"	64"	1/3	2	120V/1	5.8	5-15	676 lbs.
SPC-MX-20-5-84	5	84 3/8"	64"	1/2	2	120V/1	5.8	5-15	700 lbs.
SPC-MX-20-6-96	6	96 3/8"	77"	1/2	3	120V/1	9.7	5-15	750 lbs.

***** WARNING *****

To prevent any electrical accidents, this equipment should be installed and serviced by qualified maintenance personnel only per national electrical code standards.

Various options may be purchased with this equipment. When these options are provided the electrical circuits may be separately fused with **class "G" fuses**. If fuses must be replaced **replace with the same type and amperage fuse**.

OPERATING INSTRUCTIONS

START UP

The refrigeration system supplied with these systems are of the hermetic type. Refrigerant is metered by expansion valves which are located in the compressor housing of MX unit. Each refrigeration system is self-contained and has been leak tested, charged with refrigerant, and operated to ensure the proper operation and setting of the controls.

Energize the unit by attaching the plug to an appropriate electrical supply (115 vac, 60 hz, single phase, 12 amp) and turning on the service switch located in the compressor compartment.

Note: The compressor symbol will flash on initial startup before turning on the compressor.

Prep the unit for use by using empty food pans or covering the well. After approximately one (1) hour of operation the unit will be ready for use.

OPERATION

The system temperature is controlled by a thermostat which is located inside the compressor housing. The thermostat controls a liquid line solenoid which controls the flow of refrigerant to the evaporator of the unit.

A low pressure control (physically located in the front of the compressor compartment) is used to cycle off the compressor. The low pressure control should not be adjusted from the factory settings. Adjustment of this control may cause performance problems with the unit. The temperature is directly controlled by the thermostat.

Factory Settings for Thermostat MX Cold Pans

- Factory Set Point = 29° F
- Minimum Low Set Point r1= 24° F
- Maximum High Set Point r2 = 38° F

For instructions on setting Carel and Full Gauge Thermostats see figure and instructions provided.

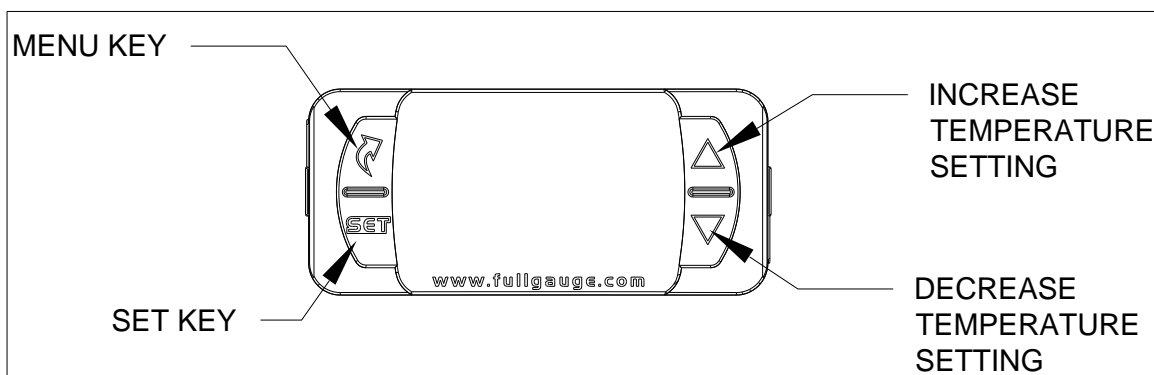
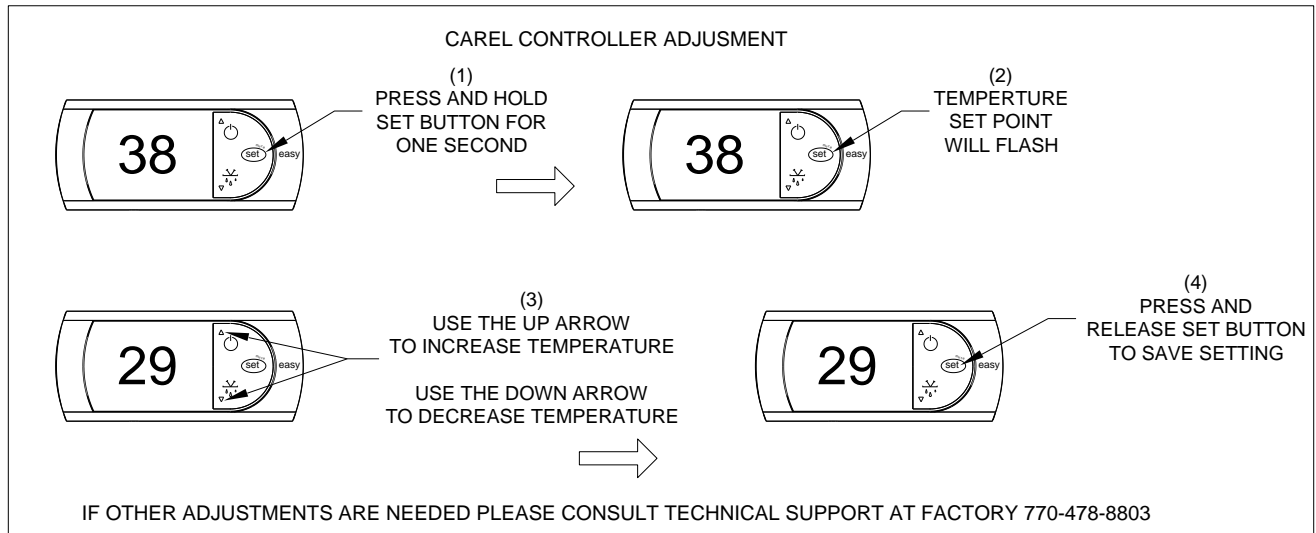

Full Gauge Control Selecting Temperature Setting

Changing Settings:

1. With the unit ON press and HOLD the SET key for 2 seconds until Set is displayed.
2. Let go of the Set key and the preset setting will be displayed on the screen.
3. To change the setting simple press the up or down arrow keys to the desired temperature.
4. Once the desired setting is selected press the Set key again to save the setting.

CLEANING INSTRUCTIONS

To maintain the performance and finish of the unit clean the unit daily. Make sure to use cleaning supplies and cleaners designed for cleaning stainless-steel surfaces.

Stainless steel:

Use soft cloths, microfiber, sponges, or plastic scouring pads. Avoid using scrapers wire brushes, steel wool or anything that might scratch the surface. Always clean stainless-steel parallel with the "grain". Use cleaners that contain alkaline, alkaline chlorinated, or non-chloride chemicals.

CONDENSER COIL

WARNING: Always disconnect power before inspecting or cleaning condenser coil. Never use high-pressure water to clean condenser coil as water can damage electrical components located near the condenser coil.

The condenser coil requires adequate cleaning to maintain proper operation which is recommend every 90 days. If debris is more prevalent the condenser coil should be cleaned every 30 days. Neglecting the condenser coil cleaning procedures will void any warranties associated with the condensing unit or cost to replace the compressor

PREVENTATIVE MAINTENANCE

To ensure that your equipment will continue to operate properly follow these simple steps.

- When cleaning these units is important to remove the power to the circulation fan and remove the fan from the unit. If the fan unit becomes wet, dry the fan assembly before applying power.
- The unit should be cleaned thoroughly every day. Excess food spillage left can cause damage to the unit. Where applicable clean unit daily.
- Make sure that the **FILTER** behind the louvered panel is always kept clean of dust and dirt. Failure to do this will cause compressor to overheat and may cause compressor failure and will VOID ANY FACTORY WARRANTY on compressor.

CONDENSER FILTER ACCESS CHANGE EVERY 30–90 DAYS

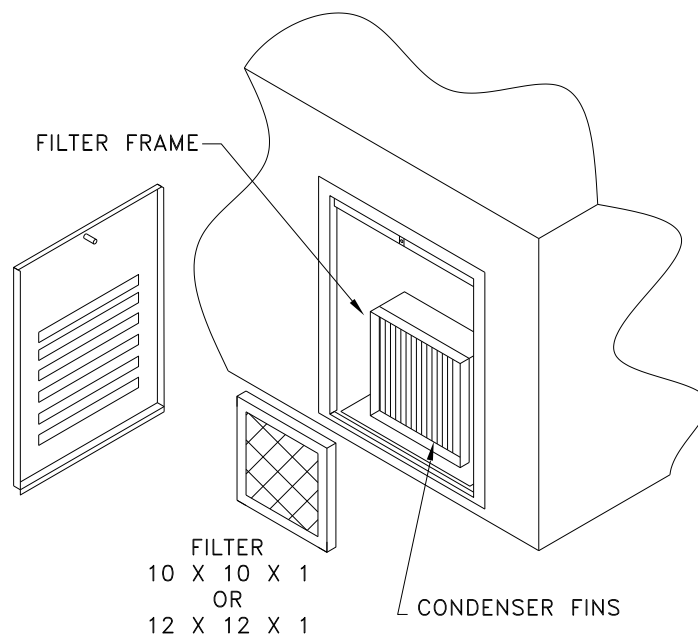

TROUBLESHOOTING

REFRIGERANT TROUBLESHOOTING		
COMPLIANT	PROBLEM	SOLUTION
COMPRESSOR WILL NOT START	LINES DISCONNECTED / SWITCH OPEN	CLOSE START ON DISCONNECT SWITCH
	FUSE REMOVED OR BLOWN	REPLACE FUSE
	CONTROL STUCK IN OPEN POSITION	REPAIR OR REPLACE CONTROL
	CONTROL OFF DUE TO COLD LOCATION	RELOCATE CONTROL
COMPRESSOR WILL NOT START, HUMS BUT TRIPS OVERLOAD PROTECTOR	LOW VOLTAGE TO UNIT	CALL POWER SUPPLIER
	STARTING CAPACITOR DEFECTIVE	REPLACE CAPACITOR
	RELAY FAILING TO CLOSE	REPLACE RELAY
	COMPRESSOR MOTOR HAS A WINDING OPEN OR SHORTED	REPLACE COMPRESSOR
	INTERNAL MECHANICAL TROUBLE IN COMPRESSOR	REPLACE COMPRESSOR
COMPRESSOR STARTS AND RUNS, BUT SHORT CYCLES ON OVERLOAD PROTECTOR	LOW VOLTAGE TO UNIT	CALL POWER SUPPLIER
	OVERLOAD PROTECTOR DEFECTIVE	CHECK CURRENT, REPLACE PROTECTOR
	RUN CAPACITOR DEFECTIVE	REPLACE CAPACITOR
	EXCESSIVED DISCHARGE PRESSURE	CHECK VENTILATION, RESTRICTIONS IN COOLING MEDIUM, RESTRICTIONS IN REFRIGERANT SYSTEM
	COMPRESSOR TOO HOT, RETURN GAS HOT	CHECK REFRIGRANT CHARGE (FIX LEAK IF NECESSARY)
	COMPRESSOR MOTOR HAS A WINDING SHORTED	REPLACE COMPRESSOR
UNIT RUNS OKAY, BUT SHORT CYCLE ON	OVERLOAD PROTECTOR	CHECK CURRENT, REPLACE PROTECTOR
	THERMOSTAT	DIFFERENTIAL SET TO CLSE, WIDEN
	HIGH PRESSURE CUT OUT DUE TO: INSUFFICIENT AIR, OVERCHARGE, OR AIR IN SYSTEM	REDUCE REFRIGERANT CHARGE, PURGE. CHECK AIR SUPPLY TO CONDENSER, REDUCE REFRIGERANT CHARGE, PURGE
UNIT OPERATES LONG OR CONTINUOUSLY	SHORTAGE OF REFRIGERANT	FIX LEAK, ADD CHARGE
	CONTROL CONTACTS STUCK OR FROZEN/CLOSED	CLEAN CONTACTS, OR REPLACE CONTROL
	REFRIGERANT OR AIR CONDITIONED SPACE HAS EXCESSIVE LOAD OR POOR INSULATION	DETERMINE FAULT AND CORRECT
	EVAPORATOR COIL ICED	DEFROST
	RESTRICTION IN REFRIGERANT SYSTEM	DETERMINE LOCATION AND REMOVE
	DIRTY CONDENSER	CLEAN CONDENSER
	FILTER DIRTY	CLEAN OR REPLACE
START CAPACITOR OPEN	RELAY CONTACTS NOT OPENING PROPERLY	CLEAN CONTACTS OR REPLACE IF NECESSARY
	PROLONGED OPERATION ON CYCLE DUE TO LOW VOLTAGE, IMPROPER RELAY	CALL POWER SUPPLIER, OR REPLACE
RUN CAPACITOR OPEN, SHORTED OR BLOWN	EXCESSIVE SHORT CYCLE	DETERMINE REASON FOR SHORT CYCLE
	IMPROPER CAPACITOR	DETERMINE CORRECT SIZE AND REPLACE
	EXCESSIVELY HIGH LINE (100% OF RATED-MAX)	CALL POWER SUPPLIER
SPACE TEMPERATURE TOO HIGH	CONTROL SETTING TO HIGH	RESET CONTROL
	INADEQUATE AIR CIRCULATION	IMPROVE AIR MOVEMENT
SUCTION LINE FROSTED OR SWEATING	EXPANSION VALVE STUCK	CLEAN VALVE OFF FOREIGN PARTICLES, REPLACE IF NECESSARY
	EVAPORATOR FAN NOT RUNNING	DETERMINE REASON AND CORRECT
	OVERCHARGE OF REFRIGERANT	CORRECT CHARGE
CONTROL DISPLAYING "Er 1" or "EO"	ERROR IN SENSOR PROBE, SENSOR DISCONNECTED OR DAMAGED	REPLACE SENSOR PROBE

REPLACEMENT PARTS

ITEM NO.	DESCRIPTION	STOCK NO.	MFG NO.	MANUFACTURER
1	CONDENSING UNIT	311949C1	AE4440Y-AA1ASC	TECUMSEH
1A	CONDENSING UNIT	311964	M7GP-H066-CFA	COPELAND
2	COMPRESSOR (AEA4440YXA)	311979	AE1322E-679-J7	TECUMSEH
2A	COMPRESSOR (M7GP-H066)	311964A	RFT18C1E-PFA-201	COPELAND
4	PRESSURE CONTROL	280610	012-4834-000	RANCO
5	DIGITAL PRESSURE CONTROL	311938	TECUMSEH P/N-900-11968	DIXELL
6	FILTER DRIER	282310	C-052-S-T-HH	SPORLAN
7	SIGHT GLASS	282400	SA-12S	SPORLAN
8	ACCUMULATOR	311810	102-10034	TECUMSEH
8A	ACCUMULATOR	281710	060819	EMERSON
9	TXV	282581	Y1017-FJ-1/8-C	PARKER HANNIFIN
10	LIQUID LINE SOLENOID	281610	E3S120W	SPORLAN
11	ROCKER SWITCH 1PL- 20A/125V	335912	RSCA201-VB-B-1-V	CARLING
12	CAREL DIGITAL THERMOSTAT	280860	PJEZSNH100	CAREL
13	THERMOSTAT PROBE	280865	NTC030HP00	CAREL
14	FULL GAUGE DIGITAL THERMOSTAT	280915	MT-512E-2HP	FULL GAUGE
15	FULL GAUGE PROBE	280925	SB-41	FULL GAUGE

DIAGRAMS

SPC-MX WIRING DIAGRAM MECHANICAL PRESSURE CONTROL

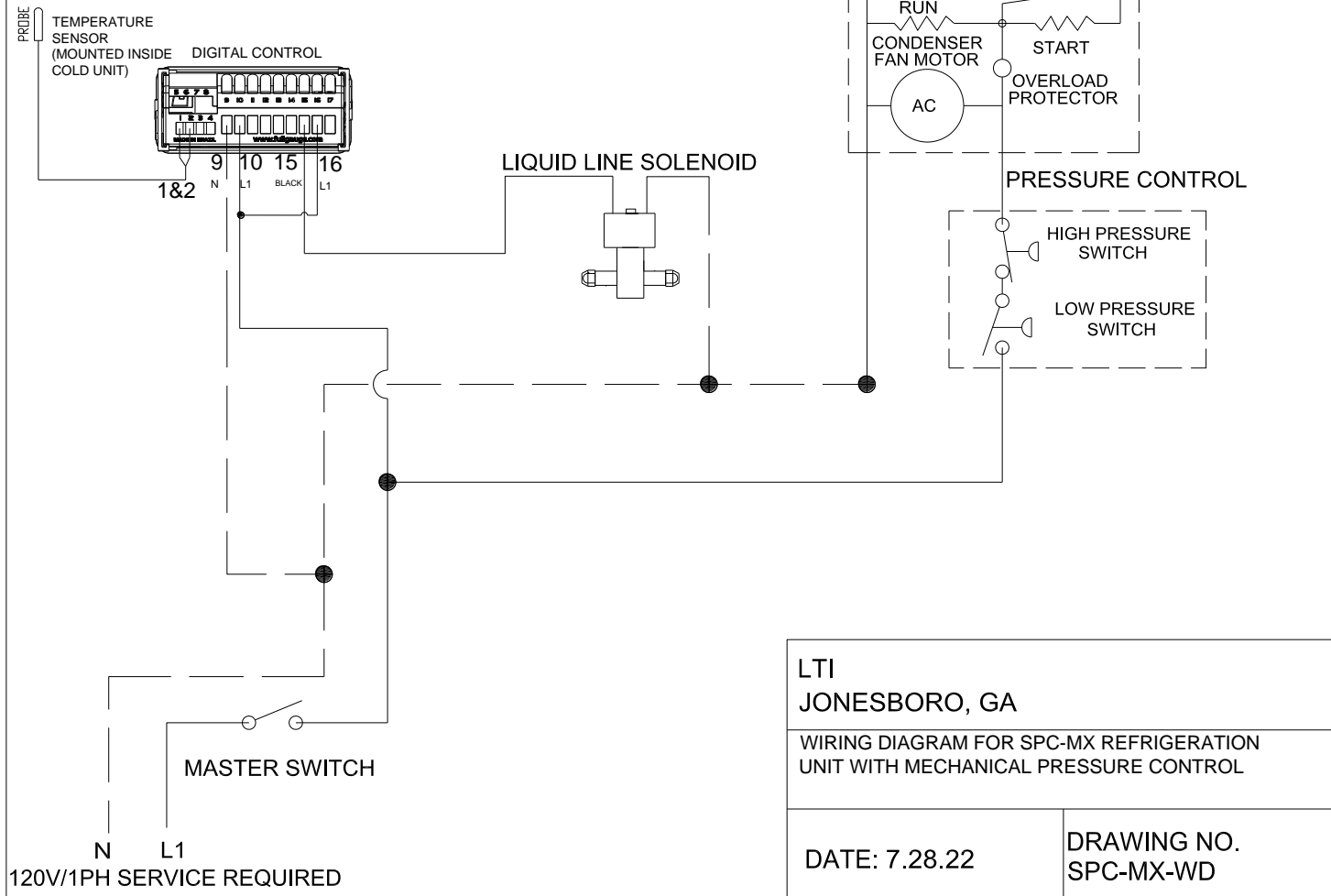

SPC-MX WIRING DIAGRAM CAREL CONTROL

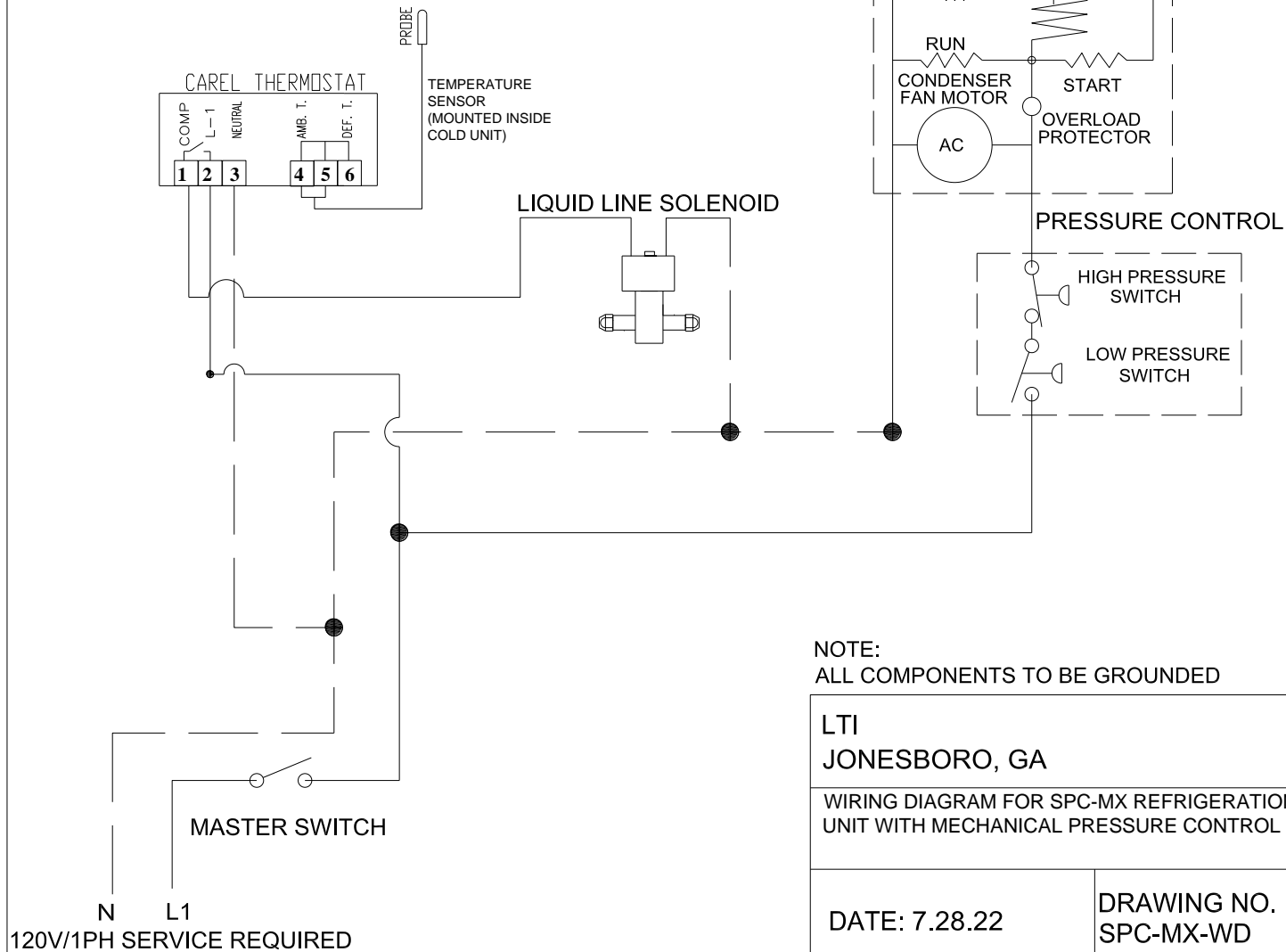

CONDENSING UNIT / PRESSURE CONTROL BOX

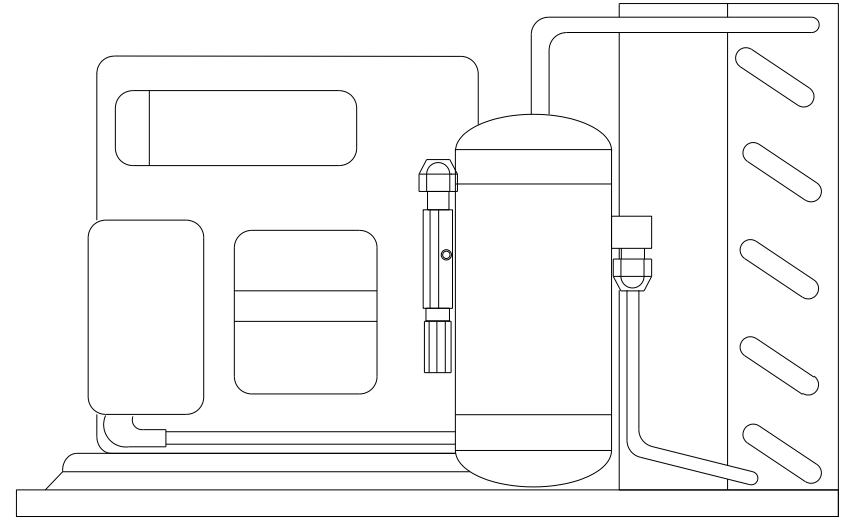
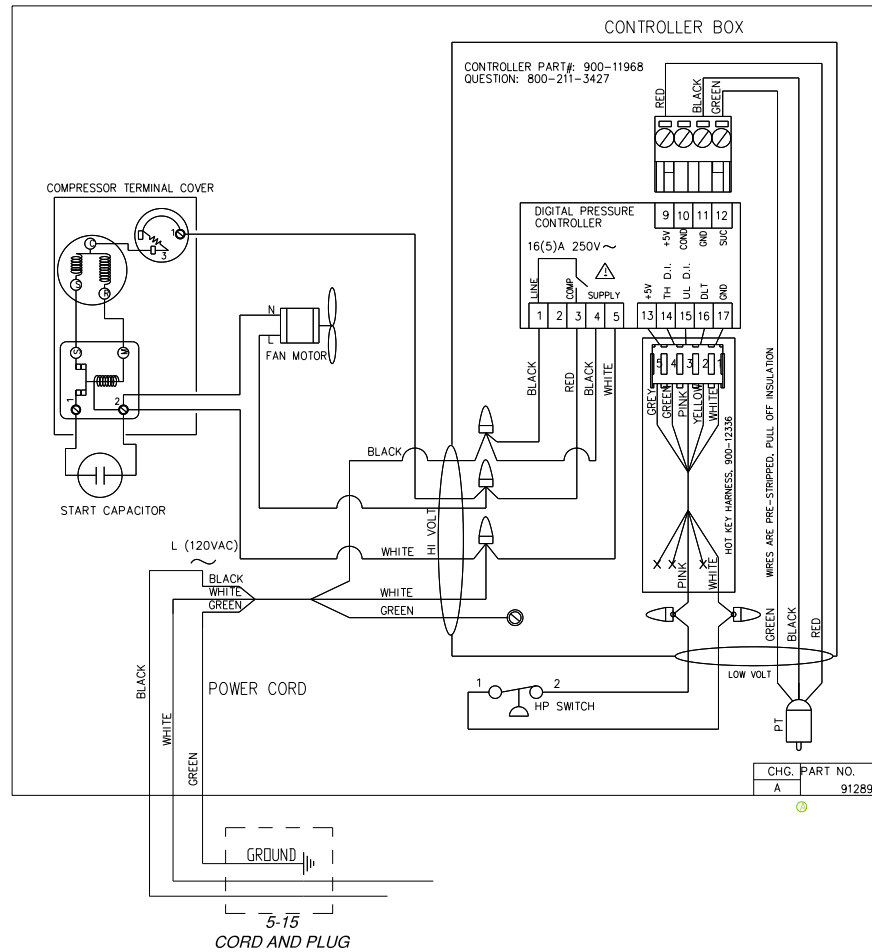

CONDENSING UNIT / MECHANICAL PRESSURE CONTROL BOX

PRESSURE
CONTROL

CONDENSING UNIT

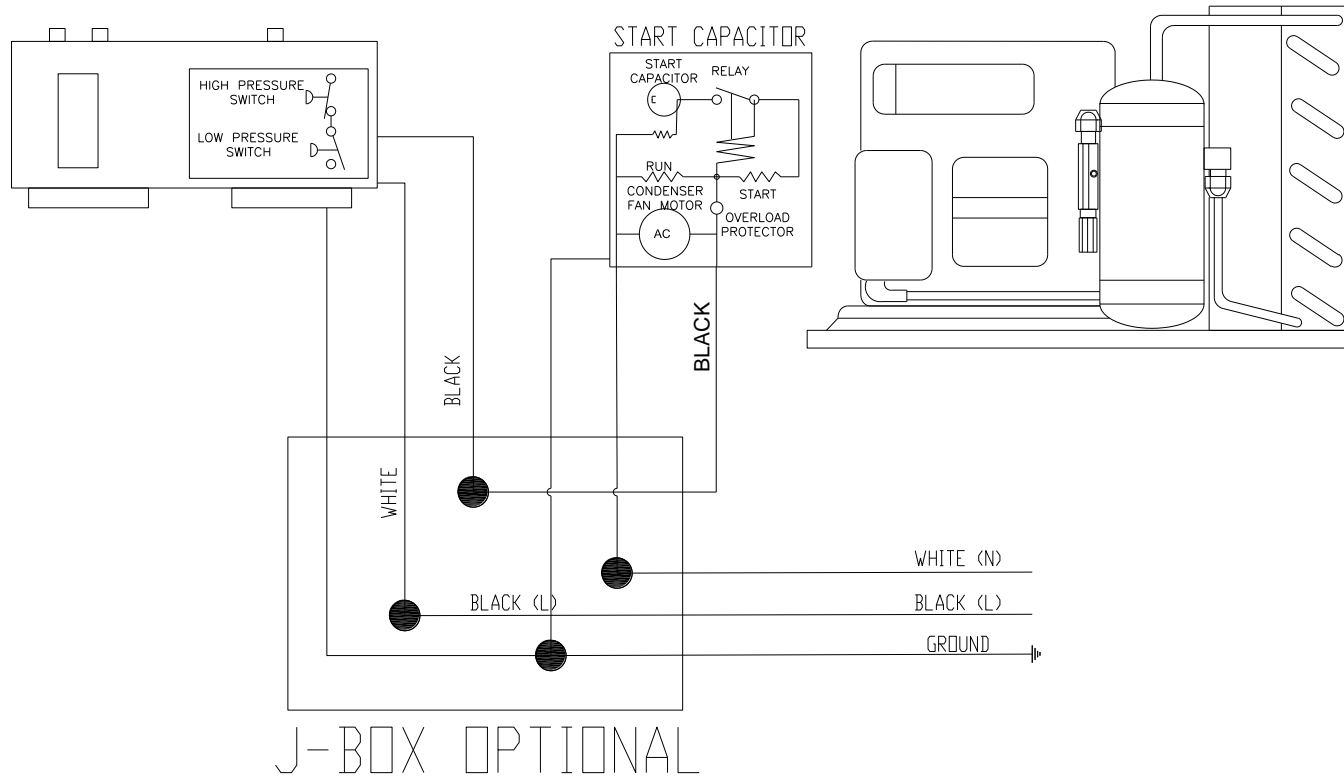

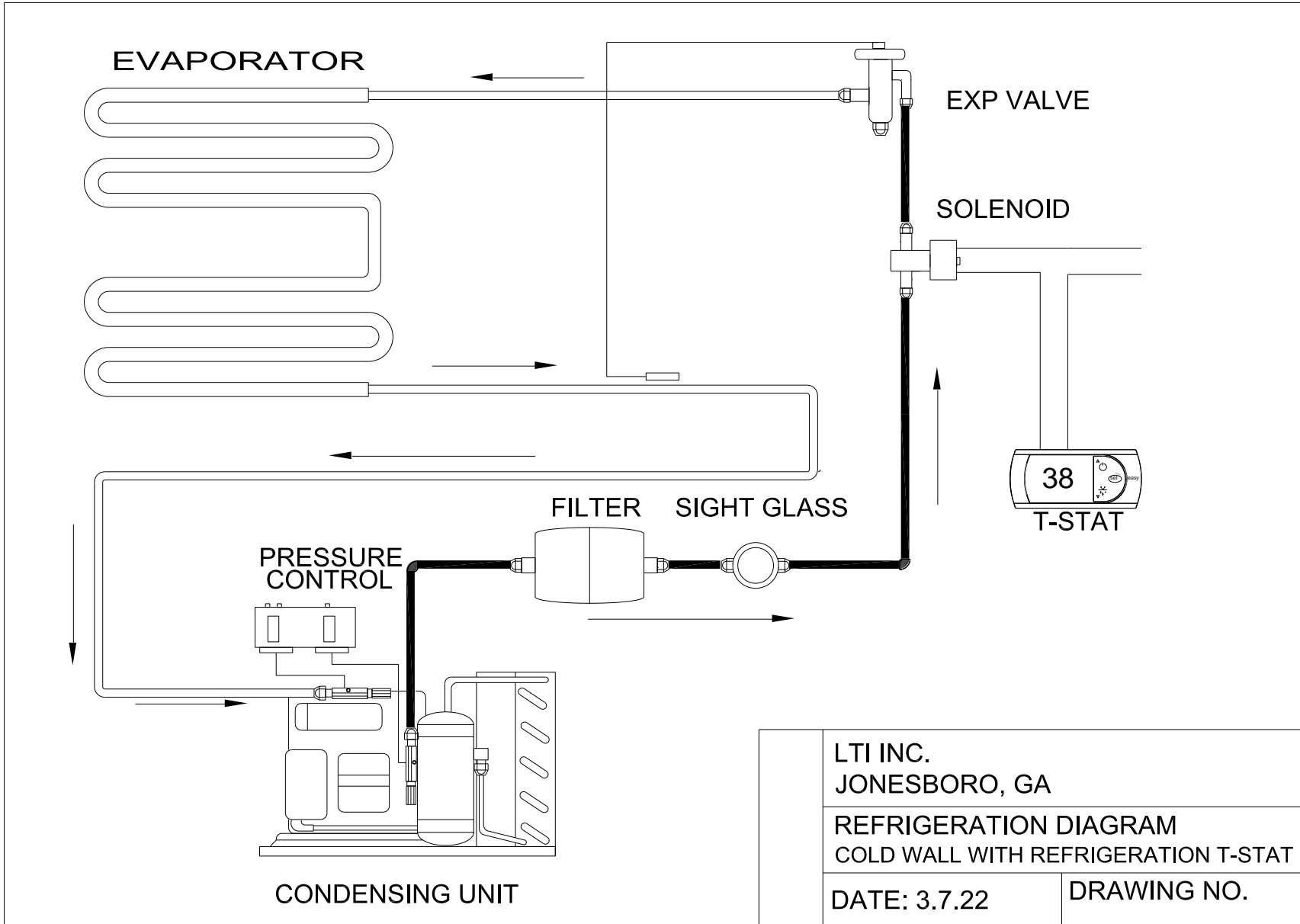

WARRANTY

Effective date July 1st, 2020

The LTI parts and labor warranty for all products is (1) year for all products (some product families have total of two-year parts and labor); The warranty period commences with the date of installation, or six (6) months from date of shipment from the factory, whichever is sooner. Refrigeration compressors come standard with a 5-year compressor warranty. The warranty covers all products used in United State and Canada. All labor and parts expense after the expiration of the warranty shall be the responsibility of the owner.

The QuickSwitch Family, TempestAir and ThermalWell families all include a 2yr parts and labor warranty.

K-12 warranty is 2 years parts and labor on ALL equipment.

All warranty labor is to be pre-authorized by the factory. To request warranty please go to <https://lowtempind.com/resources/warranty/> or call 888-584-2722 for pre-authorization and ask for the warranty department.

The warranty includes travel time to portal, not to exceed 100 miles round trip, or two hours total travel time. The warranty requires that all labor must be performed during regular work hours. Overtime premiums will be charged to the owner or must be pre-approved prior to the service call. The warranty does not apply to any equipment or component parts which have been subjected to shipping damage, improper voltage, improper installation, alteration, abuse, or misuse. The warranty does not cover routine maintenance activities, any failure that results from lack of, or improper equipment maintenance activities. The warranty does not cover any loss of business profits, any loss of food, or other products, or damage to property due to electrical, gas or mechanical malfunction or to any incidental or consequential damages of Purchaser or any third party. Damage due to floods, fire or other acts of God also are not covered.

Due to the custom nature of the products returns are not allowed. All inquiries concerning this warranty must be directed to LTI.

LTI
1947 Bill Casey Parkway • Jonesboro, GA 30236
Tel: 888-584-2722 • Fax: 1 (770)-471-3715
www.lowtempind.com