



INSTALLATION AND OPERATING INSTRUCTIONS

PUMP

Model: LSTI - 8 1/2 - B5

IMPORTANT FOR FUTURE REFERENCE

Please complete this information and retain this manual for the life of the equipment. For Warranty Service and/or Parts, this information is required.

 Model Number

 Serial Number

 Date Purchased

CONTENTS

General Information	2
Maintenance.....	2
Cleaning.....	3
Installation	3
Operation	3
Adjustment	3
Parts List w/Exploded View.....	4
Warranty.....	7



WARNING: Improper installation, operation, service or maintenance can cause property damage, injury or death. Read and understand these instructions thoroughly before positioning, installing, maintaining or servicing this equipment.



P/N 88765-00 9/05

APW WYOTT Foodservice Equipment Company

P.O. Box 1829
Cheyenne, WY 82003

+1 (307) 634-5801 Phone
+1(307) 637-8071 Fax

+1 (800) 752-0863 Toll Free
www.apwwyott.com

GENERAL INFORMATION

THIS MANUAL SHOULD BE RETAINED FOR FUTURE REFERENCE



CAUTION: These models are designed, built, and sold for commercial use. If these models are positioned so the general public can use the equipment, make sure that cautions, warnings, and operating instructions are clearly posted near each unit so that anyone using the equipment will use it correctly and not injure themselves or harm the equipment.



MAINTENANCE



WARNING: Never clean any electrical unit by immersing it in water. Turn unit off before cleaning surface.



Once a week or more often if necessary clean the unit thoroughly.

STAINLESS STEEL: To remove normal dirt or product residue from stainless steel, use ordinary soap and water (with or without detergent) applied with a sponge or cloth. Dry thoroughly with a clean cloth. Never use vinegar or corrosive cleaners. Do not use chlorine based cleaners.

To remove grease and food splatter or condensed vapors that have baked on the equipment, apply cleaners to a damp cloth or sponge and rub cleanser on the metal in the direction of the polished lines on the metal. Rubbing cleanser as gently as possible in the direction of the polished lines will not mar the finish of the stainless steel. NEVER RUB WITH A CIRCULAR MOTION. Soil and burnt deposits which do not respond to the above procedure can usually be removed by rubbing the surface with SCOTCH-BRITE scouring pads or STAINLESS scouring pads.



CAUTION: DO NOT USE ordinary steel wool as any particle left on the surface will rust.



NEVER USE a wire brush, steel or abrasive scouring pads (except stainless), scraper, file or other steel tools. Surfaces which are marred collect dirt more rapidly and become more difficult to clean. Marring also increases the possibility of corrosive attack.

NEVER use any corrosive cleaner. Use only cleaners approved for stainless steel.

NEVER use cleaning solvents with a hydrocarbon base.

Congratulations on your purchase of APW Wyott commercial cooking or refrigeration equipment. **APW Wyott** takes pride in the design and quality of our products. When used as intended and with proper care and maintenance, you will experience years of reliable operation from this equipment. To ensure best results, it is important that you read and follow the instructions in this manual carefully.

IMMEDIATELY INSPECT FOR SHIPPING DAMAGE

All containers should be examined for damage before and during unloading. The freight carrier has assumed responsibility for its safe transit and delivery. If equipment is received damaged, either apparent or concealed, a claim must be made with the delivering carrier.

A) Apparent damage or loss must be noted on the freight bill at the time of delivery. It must then be signed by the carrier representative (Driver). If this is not done, the carrier may refuse the claim. The carrier can supply the necessary forms.

B) Concealed damage or loss if not apparent until after equipment is uncrated, a request for inspection must be made to the carrier within 15 days. The carrier should arrange an inspection. Be certain to hold all contents and packaging material.

Installation and start-up should be performed by a qualified installer who thoroughly read, understands and follows these instructions.

If you have questions concerning the installation, operation, maintenance or service of this product, write Technical Service Department APW Wyott Foodservice Equipment Company, P.O. Box 1829, Cheyenne, WY 82003.

CLEANING

Before this pump is used for the first time, clean the pump thoroughly with a non-chlorine based sanitizing solution which meets local and/or national health codes. Clean by running a brush through the spout and tube to remove any dirt or manufacturing material.

The pump should be cleaned daily according to the instructions below. **Note the way the pump comes apart so that you can reassemble it in reverse order.**

1. Holding the pump upright, unscrew the base of the cup and remove the cup and tie rod.
2. Remove the tie rod nut and the check valve. **NOTE: Be careful not to misplace the check valve.**
3. While holding the piston assembly, turn the upper spring cage counterclockwise and remove it.
4. Remove the lower spring cage and spring.
5. Remove the piston assembly.
6. Wash all pump parts thoroughly in a sanitizing solution using the brushes provided; rinse in hot water and allow the pump to air dry.
7. Reassemble using reverse procedure. **NOTE: The pump is now ready to use.**

CAUTION: If used in a heated container, allow the pump to cool before disassembling, cleaning or adjusting it. Failure to do so may result in severe burns.

INSTALLATION

1. Clean the pump thoroughly in a sanitizing solution, using the brushes provided. Rinse in hot water and allow to air dry.
2. Select a disk from the condiment card to identify the product to be dispensed. **NOTE:** If the condiment you are serving does not appear on the disks, turn the disk over and mark the name on the back.
3. Unscrew the lever knob from the lever and place the disk under the clear insert.
4. Replace the lever knob. The pump and lid may now be placed in a container.

OPERATION

To operate the pump, press the lever knob until it stops, and then release it. A brisk, smooth stroke delivers the condiment uniformly.

ADJUSTMENT

Adjust the pump to deliver the amount of condiment you require. The cup capacity is 5 ounces.

1. Remove the lever screw and fold the lever back out of the way.
2. Turn the upper spring cage clockwise for a smaller portion of condiment and counterclockwise for a larger portion.
3. Turn the upper spring cage so that the lever fits down into the slot.
4. Replace the lever and lever screw.

PARTS LIST & EXPLODED VIEW

ITEM	PART NUMBER	DESCRIPTION	QUANTITY
1	569-00	Lever	1
2	591-00	Lever Knob	1
3	581-00	Lever Screw	1
4	24070-00	Clear Insert	1
5	676-00	Upper Spring Cage	1
6	40677-00	Lower Spring Cage	1
7	89110-00	Spring	1
8	979-00	Link	1
9	81361-00	Screw, Flathead #8-32 x 3/8" slotted	2
10	1406-00	Piston	1
11	1408-00	Tie Rod	1
12	508-00	Tie Rod Nut	1
13	507-00	Check Valve	1
14	972-00	Cup	1
15	4496-50	Lid and Spout	1
16	88550-00	Condiment Card	(Not shown)
17	30247-00	Cleaning Brush, Large	(Not shown)
18	30254-00	Cleaning Brush, Small	(Not shown)
19	88765-00	Pump Instructions	(Not shown)

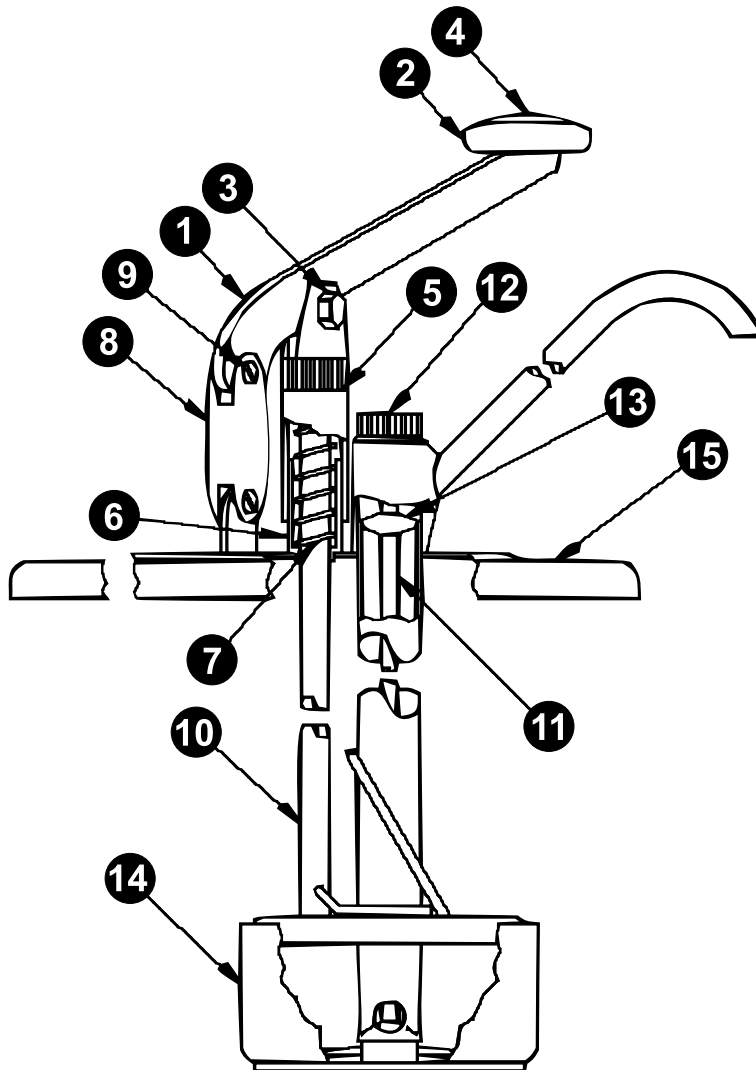

APW WYOTT EQUIPMENT LIMITED WARRANTY

APW Wyott Foodservice Equipment Company warrants its equipment against defects in materials and workmanship, subject to the following conditions:

This warranty applies to the original owner only and is not assignable.

Should any product fail to function in its intended manner under normal use within the limits defined in this warranty, at the option of APW Wyott such product will be repaired or replaced by APW Wyott or its Authorized Service Agency. APW Wyott will only be responsible for charges incurred or service performed by its Authorized Service Agencies. The use of other than APW Wyott Authorized Service Agencies will void this warranty and APW Wyott will not be responsible for such work or any charges associated with same. The closest APW Wyott Authorized Service Agent must be used.

This warranty covers products shipped into the 48 contiguous United States, Hawaii, metropolitan areas of Alaska and Canada. There will be no labor coverage for equipment located on any island not connected by roadway to the mainland.

Warranty coverage on products used outside the 48 contiguous United States, Hawaii, and metropolitan areas of Alaska and Canada may vary. Contact the international APW Wyott distributor, dealer, or service agency for details.

Time Period

One year for parts and one year for labor, effective from the date of purchase by the original owner. The Authorized Service Agency may, at their option, require proof of purchase. Parts replaced under this warranty are warranted for the un-expired portion of the original product warranty only.

Exceptions

- ***Gas/Electric Cookline:** Models GCB, GCRB, GF, GGM, GGT, CHP-H, EF, EG, EHP. Three (3) Year Warranty on all component parts, except switches and thermostats. (2 additional years on parts only. No labor on second or third year.)
- ***Broiler Briquettes, Rock Grates, Cooking Grates, Burner Shields, Fireboxes:** 90 Day Material Only. No Labor.
- ***Heat Strips:** Models FD, FDL, FDD, FDDL. Two (2) Year Warranty on element only. No labor second year.
- ***Glass Windows, Doors, Seals, Rubber Seals, Light Bulbs:** 90 Day Material Only. No Labor.

In all cases, parts covered by extended warranty will be shipped FOB the factory after the first year.

Portable Carry In Products

Equipment weighing over 70 pounds or permanently installed will be serviced on-site as per the terms of this warranty. Equipment weighing 70 pounds or under, and which is not permanently installed, i.e. with cord and plug, is considered portable and is subject to the following warranty handling limitations. If portable equipment fails to operate in its intended manner on the first day of connection, or use, at APW Wyott's option or its Authorized Service Agency, it will be serviced on site or replaced.

From day two through the conclusion of this warranty period, portable units must be taken to or sent prepaid to the APW Wyott Authorized Service Agency for in-warranty repairs. No mileage or travel charges are allowed on portable units after the first day of use. If the customer wants on-site service, they may receive same by paying the travel and mileage charges. Exceptions to this rule: (1) countertop warmers and cookers, which are covered under the Enhanced Warranty Program, and (2) toasters or rollergrills which have in store service.

Exclusions

The following conditions are not covered by warranty:

- *Equipment failure relating to improper installation, improper utility connection or supply and problems due to ventilation.
- *Equipment that has not been properly maintained, calibration of controls, adjustments, damage from improper cleaning and water damage to controls.
- *Equipment that has not been used in an appropriate manner, or has been subject to misuse or misapplication, neglect, abuse, accident, alteration, negligence, damage during transit, delivery or installation, fire, flood, riot or act of god.
- *Equipment that has the model number or serial number removed or altered.

If the equipment has been changed, altered, modified or repaired by other than an Authorized Service Agency during or after the warranty period, then the manufacturer shall not be liable for any damages to any person or to any property, which may result from the use of the equipment thereafter.

This warranty does not cover services performed at overtime or premium labor rates. Should service be required at times which normally involve overtime or premium labor rates, the owner shall be charged for the difference between normal service rates and such premium rates. APW Wyott does not assume any liability for extended delays in replacing or repairing any items beyond its control.

In all cases, the use of other than APW Wyott Authorized OEM Replacement Parts will void this warranty.

This equipment is intended for commercial use only. Warranty is void if equipment is installed in other than commercial application.

Water Quality Requirements

Water supply intended for a unit that has in excess of 3.0 grains of hardness per gallon (GPG) must be treated or softened before being used. Water containing over 3.0 GPG will decrease the efficiency and reduce the operation life of the unit.

Note: Product failure caused by liming or sediment buildup is not covered under warranty.

“THE FOREGOING WARRANTY IS IN LIEU OF ANY AND ALL OTHER WARRANTIES EXPRESSED OR IMPLIED INCLUDING ANY IMPLIED WARRANTY OF MERCHANTABILITY OR FITNESS FOR PARTICULAR PURPOSES AND CONSTITUTES THE ENTIRE LIABILITY OF APW WYOTT. IN NO EVENT DOES THE LIMITED WARRANTY EXTEND BEYOND THE TERMS STATED HEREIN.”

9/05



APW WYOTT Foodservice Equipment Company

P.O. Box 1829
Cheyenne, WY 82003

+1 (307) 634-5801 Phone
+1 (307) 637-8071 Fax

+1 (800) 752-0863 Toll Free
www.apwwyott.com