

E80S

INSTRUCTION MANUAL

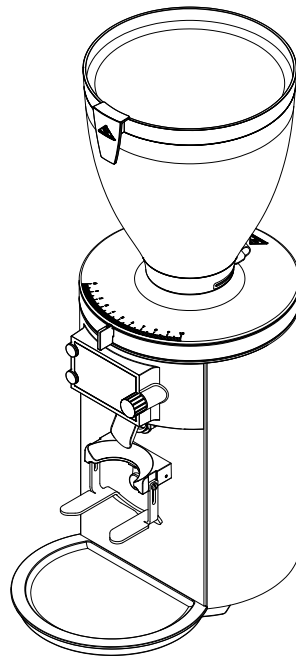

www.mahlkoenig.com

Overview

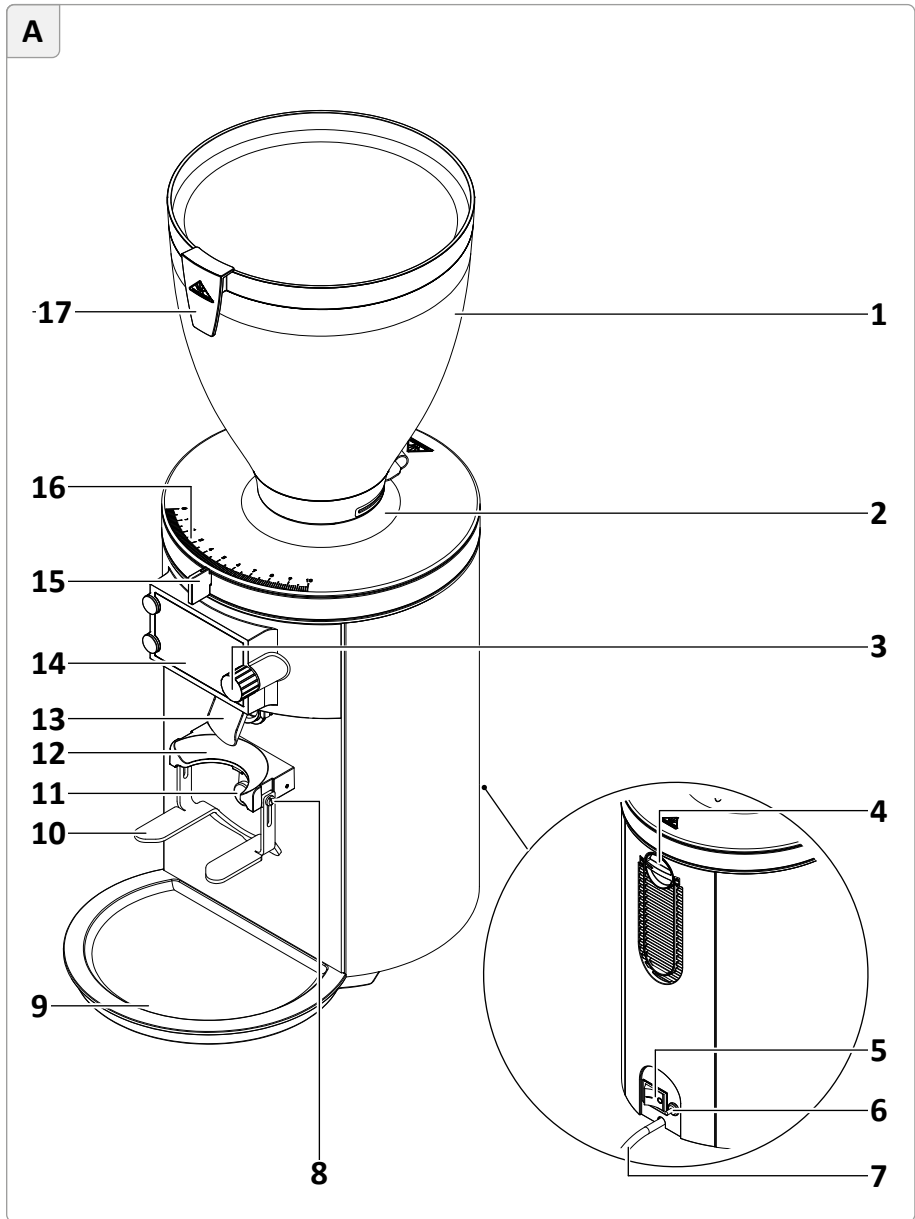

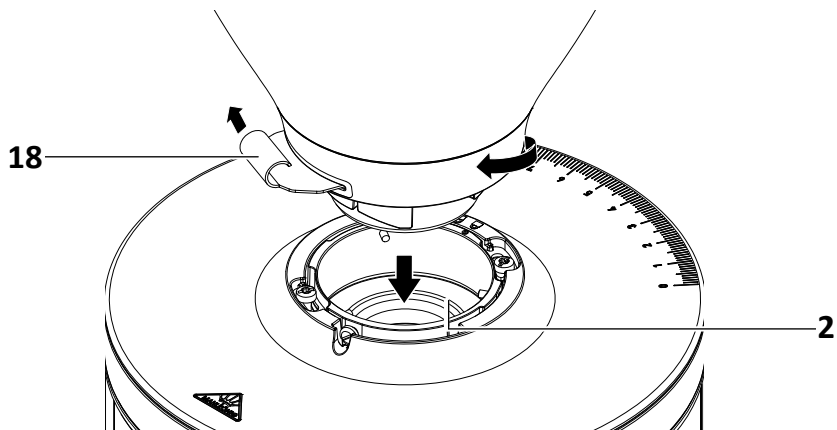
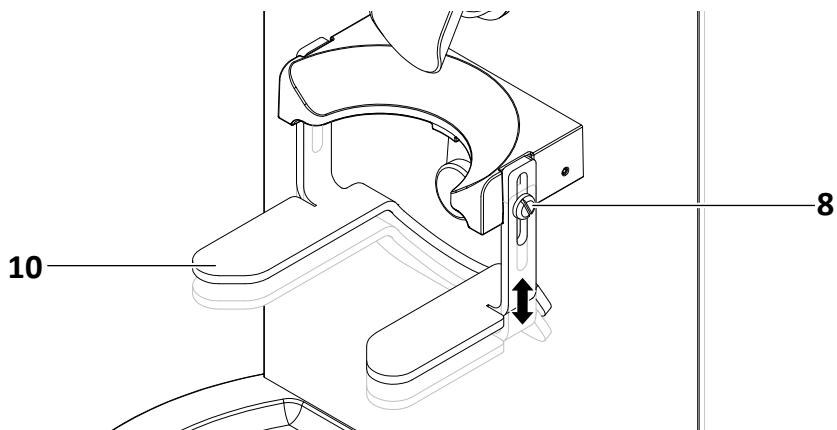
B**C**

D

13

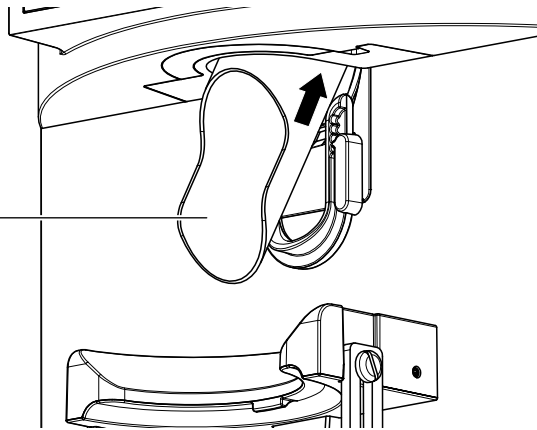

E

13

19

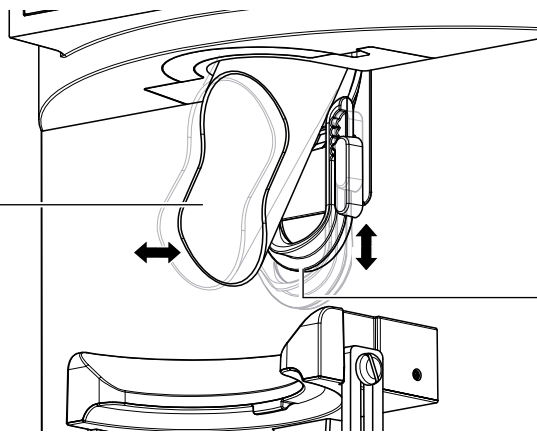

F

4

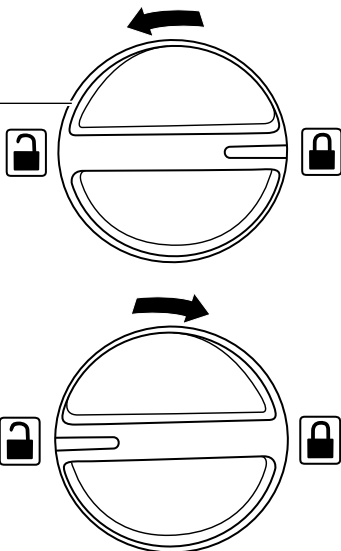
**G**

16

15

21

20

3

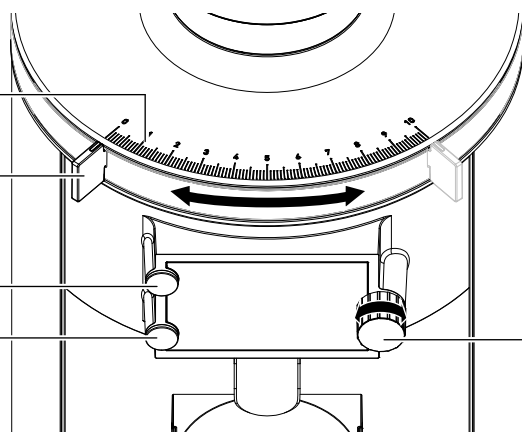

H

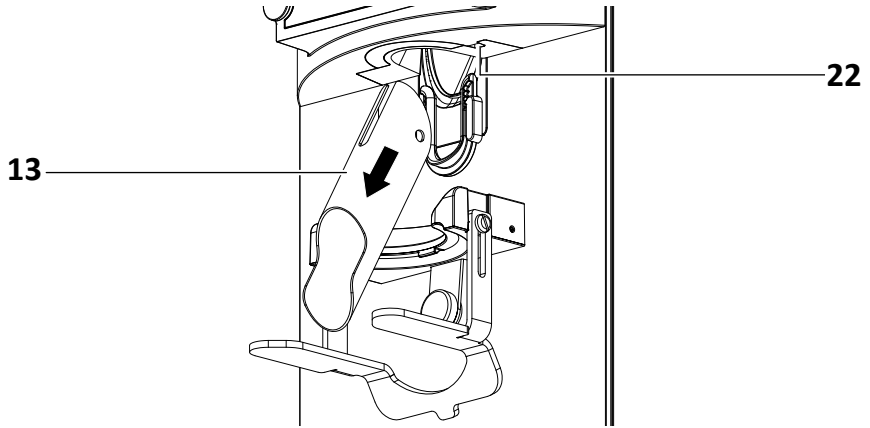

I

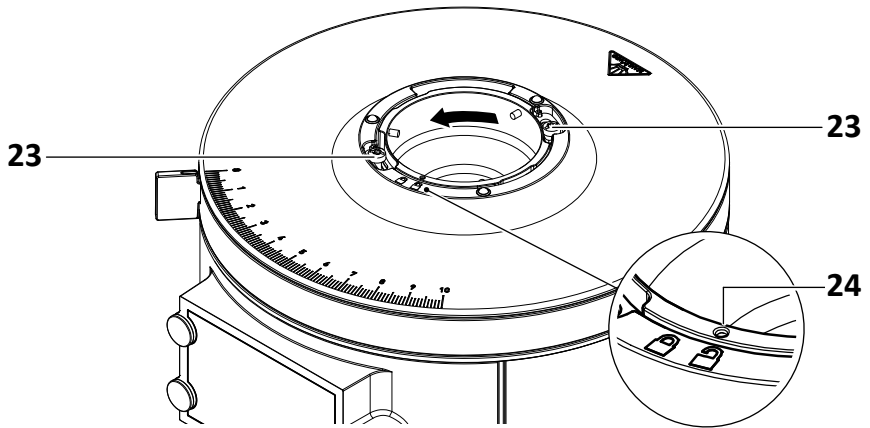

J

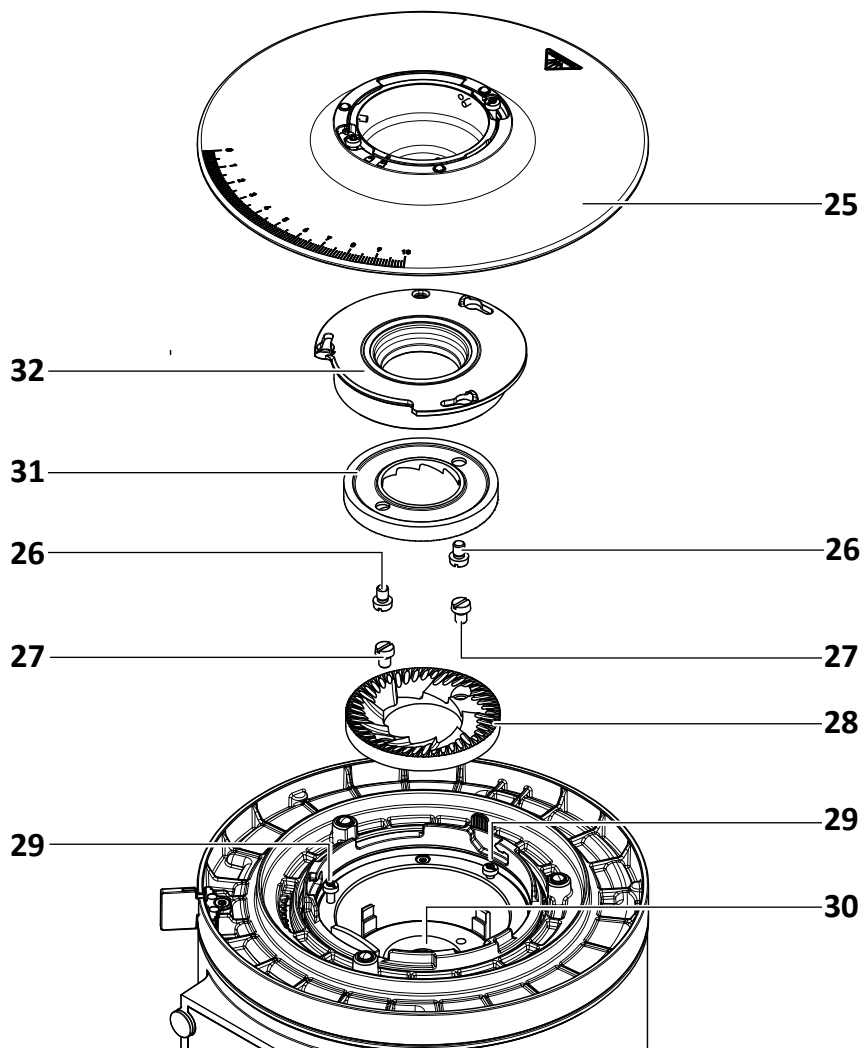

K

33

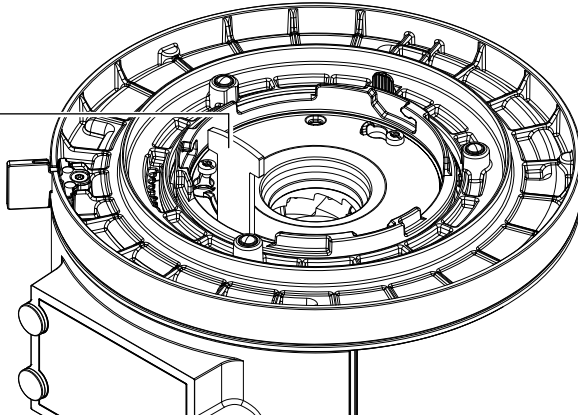

L

34

35

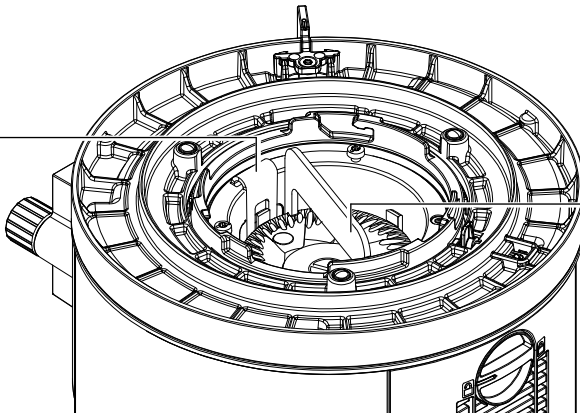

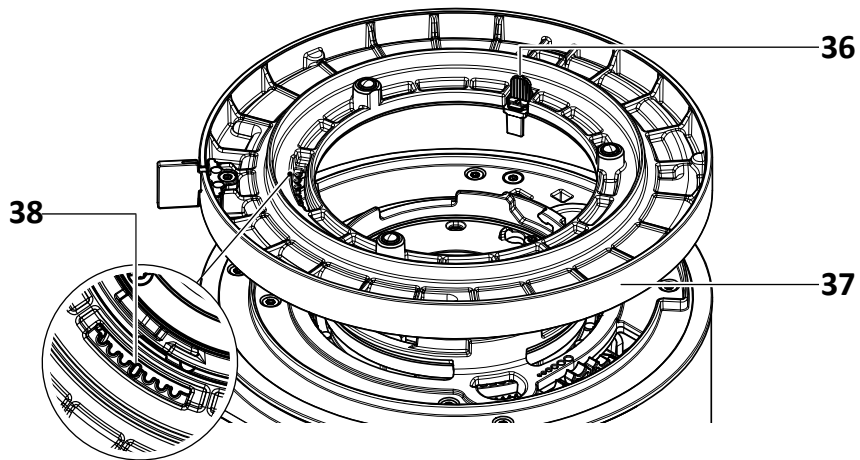
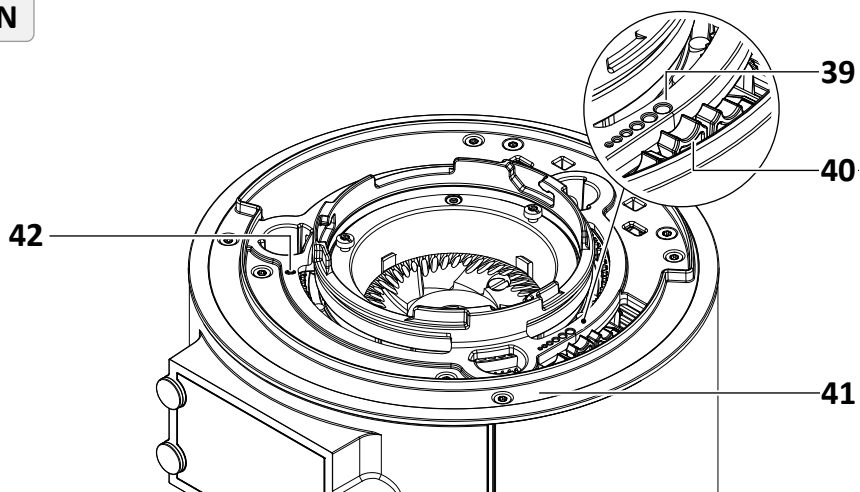
M**N**

Scope of delivery

No.	Designation	No.	Designation
1	Bean hopper (with lid)	25	Grinder lid
2	Bean hopper intake	26	Screws to the fixed burr
3	Controller	27	Screws to the rotary burr
4	Grinding degree lock	28	Rotary burr
5	On/Off switch	29	Locking screws for the fix burr flange
6	Release button (Thermal overcurrent circuit-breaker)	30	Burr carrier
7	Power cable	31	Fixed burr
8	Screw for adjusting the portafilter support (left and right), 2×	32	Fix burr flange
9	Collecting tray	33	Flapper
10	Portafilter support	34	Locking tool for changing burrs
11	Start button	35	Removal tool for changing burrs
12	Portafilter intake	36	Adjustment ring lock
13	Spout	37	Adjustment ring
14	Display	38	Adjustment ring marker
15	Grinding degree slider	39	Vernier scale
16	Grinding degree scale	40	Dial zero adjustment burr
17	Clip for the type of bean used	41	Intermediate plate
18	Slider	42	Intermediate plate marker
19	Spout guide		
20	Lower button		
21	Upper button		
22	Rescue button		
23	Locking screws grinder lid		
24	Lock/unlock grinder lid		

Contents

Overview	2	Using the main menu	26
Scope of delivery	10	Display/navigation symbols	26
General	12	Accessing and leaving the main menu.....	27
Reading and retaining the operating manual	12	Cleaning.....	28
Explanation of symbols used	12	Cleaning the grinder installation surface.....	29
Safety.....	14	Cleaning the casing.....	29
Intended use	14	Cleaning the spout system.....	29
Safety information	14	Cleaning the bean hopper	30
Before using for the first time	17	Cleaning the grinding mechanism with GRINDZ™	31
Functioning and basic settings ...	17	Cleaning the grinding mechanism manually.....	32
Checking the grinder and scope of delivery.....	17	Cleaning the flapper	33
Setting up the grinder and inserting the bean hopper.....	18	Maintenance	33
Setting up the portafilter support and spout	19	Changing the burrs	33
Operation	20	Adjusting the burrs	34
Adding espresso beans.....	21	Changing the flapper	35
Switching on the grinder	21	Troubleshooting	36
Setting the grinding degree	21	Technical data.....	40
Selecting recipes	22	Disposal	41
Setting or changing the recipe/grinding time.....	22	Disposing of the packaging.....	41
Starting grinding	23	Disposing of the grinder	41
Interrupting grinding	24	Maintenance and service ..	41
Rescue button grinding.....	24		
Changing the type of espresso beans.....	24		

General

Reading and retaining the operating manual



Before you start using the E80S espresso grinder, carefully read through this operating manual and the safety information. Only then will you be able to use the E80S espresso grinder safely and without danger. The operating manual is based on the standards

and regulations in force in the European Union. Please also observe the guidelines and laws of the respective country if abroad.

For better clarity, the E80S espresso grinder shall be referred to hereinafter simply as “grinder”.

Please keep the operating manual safe for later queries.

Please also hand the operating manual on to subsequent owners and users of the grinder.

Explanation of symbols used

The following symbols and signal words are used in this operating manual, on the grinder and on the packaging.

WARNING!



This signal word/symbol indicates a danger with a moderate degree of risk, which can lead to death or serious injury if not avoided.

CAUTION!



This signal word/symbol indicates a danger with a low degree of risk, which can lead to minor or moderate injury if not avoided.

NOTE!

This signal word warns of possible material damage.



This symbol provides you with important information concerning operation or handling.



Declaration of Conformity:
Products marked with this symbol fulfil all applicable community provisions of the European Economic Area.



Intertek

ETL Listed seal of approval:
Products marked with this symbol meet the requirements of electrical product safety in the United States of America.



Intertek

Products marked with this symbol meet the criteria required by the NSF (National Sanitation Foundation) regarding cleanliness and hygiene in the food industry.



Products marked with this symbol are only permitted for use indoors.



This symbol indicates a risk of electric shock.



This symbol indicates that the grinder conforms to protection class I.

Safety

Intended use

The grinder is only suitable for grinding whole roast espresso beans. Do not use the grinder to grind other products or objects.

The grinder is intended for commercial use but not for continuous mass production. The grinder may only be serviced by trained personnel. It may, however, be operated by other persons in a place where use is supervised. Any other use is not considered to comply with the intended use and can result in material damage or even personal injury. Do not make any modifications to the grinder. The manufacturer or supplier cannot be held liable for any injury or damage resulting from failure to comply with the safety instructions.

Safety information

WARNING!

Danger of electric shock!

Improper use, incorrect electrical installation or an excessively high voltage can all lead to electric shock.

- Connect the grinder only if the mains voltage of the socket complies with the information indicated on the type plate.
- Connect the grinder only to a socket with good accessibility, so that you can disconnect it quickly from the power supply in the event of a fault.
- Do not use the grinder if you notice any visible damage or if the power cable or plug is faulty.
- If the grinder power cable is damaged, it must be replaced by the manufacturer or by qualified personnel in order to avoid hazards.
- Do not operate the grinder without an earthed connection.
- Connect the grinder only to a power supply with a 16 A-slow back-up fuse or a 15 A load fuse (USA). Have the 16 A-slow back-up fuse or 15 A load fuse fitted by a qualified electrician if the power connection at the installation location of the grinder is not protected in this way.

- Install the grinder only in locations where handling of the grinder can be supervised by trained personnel.
 - Do not operate the grinder above an altitude of 2000 metres.
 - Do not immerse the grinder or the power cable/mains plug in water or any other liquids.
 - Do not clean the grinder with a water jet.
 - Do not clean the grinder with compressed air (e.g. with a compressed air gun).
 - Never touch the mains plug with wet hands.
 - Never unplug the mains plug from the wall socket by pulling on the power cable; always grip the plug itself.
 - Never use the power cable as a handle to carry the grinder.
 - Keep the grinder and power cable/mains plug away from open flames and hot surfaces.
 - Do not lay the power cable in such a way that it could create a tripping hazard.
 - Do not bend the power cable and do not place it over sharp edges.
 - Use the grinder in indoor areas only. Never operate the grinder in damp rooms or in the rain.
 - Keep children away from the grinder.
 - Ensure that children do not insert any objects into the grinder.
 - If you are not currently using the grinder, if you are cleaning it or if a fault occurs, switch the grinder off and remove the mains plug from the socket.
 - Do not open the grinder casing; leave repairs to the experts. If repairs are required, please contact a specialist workshop. In the event of unauthorised repairs, faulty connection or incorrect operation, all liability and guarantee claims are excluded. Only parts that comply with the original appliance specifications may be used for repairs. This grinder contains electrical and mechanical parts that are essential for protection against potential hazards.
-

 **WARNING!**

Danger for children and persons with reduced physical, sensory or mental capacities (e.g. some disabled persons, older persons with limited physical and mental abilities) or a lack of experience and knowledge (e.g. older children).

- The grinder is not intended for use by children or people with limited physical, sensory or mental abilities or a lack of experience and knowledge. Children are not permitted to play with the grinder.
 - Do not leave the grinder unsupervised when in operation.
 - Do not let children play with the packaging film. Children can become entangled in it while playing and may suffocate.
 - Do not let children play with the small parts. They can be life-threatening if swallowed.
-

 **CAUTION!**

Risk of tipping and injury!

Incorrect handling of the grinder can result in injury.

- Position the power cable so that nobody can become entangled in it and cause the grinder to fall.
 - Place the grinder on a level and stable surface to prevent it from falling off.
-

Before using for the first time

Functioning and basic settings

This grinder has a Disc Distance Detection (DDD) function, which enables the grinding degree to be set based on the distance between the burrs.

The quantity of ground coffee dispensed per shot, i.e. the dosage quantity, is determined by the grinder based on the grinding time.

The user can specify up to six different recipes (grinding times) and also has the option of controlling the grinding time manually (manual grinding).

The grinding process starts automatically when the portafilter is inserted and ends either automatically after the specified grinding time has been reached or when the portafilter is removed.



2 shots and manual grinding are set as the default on delivery.



Single shot: 1.6 seconds (approx. 12 g*)



Double shot: 2.8 seconds (approx. 18 g*)



Manual grinding: ends automatically when the portafilter is removed from the portafilter intake.

*The quantity of ground coffee depends on the selected espresso bean type, the grinding degree selected and the mains frequency (see the section “Technical data”).

Checking the grinder and scope of delivery

NOTE!

Risk of damage!

The grinder may be damaged if the packaging is opened carelessly with a sharp knife or other pointed objects.

- Be very careful when opening.

1. Remove the grinder from its packaging.
2. Check if the delivery is complete (see **Fig. A, B, E, G, H, I, J, K, L, M, and N**).
3. Check for damage to the grinder or any of the individual parts.
If damage is present, do not use the grinder. Contact your supplier (see the section “Maintenance and service”).



Please note that the grinder is subject to an extensive functional test before delivery and may therefore still contain coffee powder residue.

Setting up the grinder and inserting the bean hopper



You will need a flat-head screwdriver (not supplied) for fixing the bean hopper.

1. Place the grinder on a level, stable surface that does not shake or wobble.
2. Make sure that the spout **(13)** is pushed up as far as possible and is securely locked into the spout locking mechanism (see **Fig. D**).
3. Make sure that the grinder is switched off (On/Off switch **(5)** to “0”) and connect the grinder to the power supply by inserting the power plug into a properly installed safety socket.
4. Place the collecting tray **(9)** into the corresponding recess in the casing under the spout.
5. Place the bean hopper **(1)** onto the bean hopper intake **(2)**.
When placing the bean hopper on, make sure that you place the nose of the bean hopper into the corresponding recess in the bean hopper intake.
6. Push the bean hopper down into the bean hopper intake and turn the bean hopper clockwise to fix it to the grinder.
If the bean hopper cannot be fixed in place by turning it, it may not be positioned correctly. In this case, align the bean hopper correctly (see step 5) and then try again by pressing it down and turning it (see also the “Troubleshooting” chapter).



The grinder automatically switches off if the bean hopper is not attached.

Setting up the portafilter support and spout



You will need a flat-head screwdriver to adjust the portafilter support (not included in the scope of delivery).

Adjust the portafilter support **(10)** to the size of your espresso machine's portafilter (see **Fig. C**):

1. Make sure that the grinder is switched off (On/Off switch **(5)** to position "0").
2. Turn anticlockwise using a flat-head screwdriver to loosen the screws **(8)** for adjusting the portafilter support (left and right).
The portafilter support is lowered as far as it will go.
3. Insert the portafilter into the portafilter support **(12)**.
4. Push the portafilter support upwards until the portafilter fits exactly between the portafilter support and the portafilter intake.



If the portafilter support does not fit, contact your supplier (see chapter "Maintenance and service").

5. Hold the portafilter support in position and fix it by turning the screws for adjusting the portafilter support (left and right) clockwise until tight using a flat-head screwdriver.
6. Push the spout guide **(19)** up or down in the lock to align the spout **(13)** in the optimal position for your portafilter (see **Fig. E**).
Align the spout so that the ground coffee falls from the spout into the centre of the portafilter.

Operation

NOTE!

Danger of overheating!

Exceeding the maximum permissible operating cycle can cause the grinder to overheat.

- Do not exceed the maximum operating cycle (see the section “Technical data”).
 - Observe the recommended pause when the maximum permissible operating cycle is reached (see the section “Technical data”).
-



- The grinder has a thermal overcurrent circuit-breaker which interrupts the electric circuit of the grinder in case of electrical overload.
To put the grinder into operation again, set the on/off switch **(5)** to switch position 0 (off).
Then press the release button **(6)**.
You can switch the grinder back on by setting the on/off switch to switch position I and putting the grinder into operation (see chapter “Troubleshooting”).
 - The grinder also has a motor protector, which switches off the grinder when the motor becomes too hot.
As soon as the motor has cooled down, the grinder can be operated again (see the section “Troubleshooting”).
-

NOTE!

Risk of damage!

The operator has no influence on the thermal overcurrent circuit-breaker. If the thermal circuit-breaker has been triggered several times, an authorised service partner must be contacted for advice as the motor winding can become damaged.

Adding espresso beans

1. Remove the lid from the bean hopper **(1)**.
2. Pour whole roasted espresso beans into the bean hopper from above.



- The maximum filling quantity should be approx. 1 cm below the edge of the bean hopper.
- The minimum filling quantity should be approx. 1 cm above the finger protection to ensure that there are no dispensing fluctuations.

3. Place the lid back onto the bean hopper.
4. If necessary, open the bean hopper by pulling out the slider **(18)** (see **Fig. B**).



You can use the clip **(17)** on the lid of the bean hopper to attach a label or something similar to indicate the type of espresso beans currently used in the grinder.

Switching on the grinder

1. Ensure that you have inserted the mains plug into a properly installed safety socket.
2. Switch on the grinder by switching the On/Off switch **(5)** to “I”.
The grinder is ready for operation as soon as the last selected recipe / the start screen appears on the display **(15)**.

Setting the grinding degree



- Locking the grind adjustment locks the grinding degree slider against unintentional adjustment of the grinding degree.
 - When the grinding degree lock is open, the grinding degree slider can move freely along the grinding degree scale. The finest setting is “0” and the coarsest setting is “10”.
1. If necessary, release the lock on the grind adjustment by turning the grinding degree lock **(4)** anticlockwise to the  (open) position (see **Fig. F**).
 2. Move the grinding degree slider **(15)** into the position required so that the marking on the slider points towards the grinding degree required on the grinding degree scale **(16)** (see **Fig. G**).



- Reduce the grinding degree only while the grinder is in operation.
 - In order to prevent/eliminate any imbalances in the grinding degree setting, it is advisable first to set a coarser grinding degree (about one step/unit above the grinding degree required) and then move the grinding degree slider from there down to the finer grinding degree required.
3. If necessary, fix the grind adjustment by turning the grinding degree lock clockwise to the  (closed) position (see **Fig. F**).

Selecting recipes

- Turn the controller **(3)** to select the desired recipe (see **Fig. G**) and confirm your choice by pressing the controller.
The symbol of the selected recipe and the corresponding grinding time are highlighted on the display **(14)**.

Setting or changing the recipe/grinding time

Proceed as follows if you would like to change the grinding time of a new recipe or if you want to change that of an existing recipe:

1. Select the desired recipe by turning the controller **(3)** (see the “Selecting recipes” chapter).
2. Press the lower button **(20)**.
The grinding time is highlighted.
3. Turn the controller to set the desired grinding time.
4. Confirm the grinding time by pressing the top button **(21)** (symbol ✓) or discard the setting by pressing the lower button (symbol ✕).



If you do not make any changes to the settings for over 4 minutes (by turning/pressing the controller/control buttons), the grinding time setting/change you have started will be cancelled.

Starting grinding

Grinding according to a recipe

1. Select the desired recipe by turning the controller **(3)** (see the “Selecting recipes” chapter).
2. Insert the portafilter between the portafilter intake **(12)** and the portafilter support **(10)** until it touches the start button **(11)**.
The grinder starts the grinding process automatically, it runs for the set grinding time and then stops. During the grinding process, the remaining grinding time is shown on the display **(14)**.
3. The LED lighting changes to green and signals that the grinding process has been completed.
Remove the portafilter.

Manual grinding

Using the start button

1. Insert the portafilter between the portafilter intake **(12)** and the portafilter support **(10)** until it touches the start button **(11)**.
The grinder starts the grinding process automatically when the start button is triggered. During the grinding process, the remaining grinding time is shown on the display.
2. Remove the portafilter from the portafilter intake when you wish to end the grinding process before the grinding time is up.

Using the upper button

1. Insert the portafilter between the portafilter intake **(12)** and the portafilter support **(10)** until before it touches the start button **(11)**.
2. Press the upper button **(21)** to trigger the grinding process manually.
3. End the grinding process by no longer pressing and holding the upper button.



Manual grinding using the upper button or the start button allows you to add very small quantities of ground coffee to a shot when grinding using a recipe.

Interrupting grinding

Grinding stops automatically when you remove the portafilter from the portafilter intake**(12)** and continues with grinding when you insert the portafilter back into the portafilter support again and press the start button **(11)** .

1. Remove the portafilter from the portafilter intake during grinding to interrupt grinding and stop the grinding time. The symbol of the selected recipe flashes.
2. Reinsert the portafilter between the portafilter intake and the portafilter support **(10)** before the abort time elapses.

The suspended grinding process is continued automatically until the grinding time has elapsed.



- If you do not want to continue with the grinding process, then press the controller button **(3)**.
The display jumps directly to the selected mode and the previously suspended time is deleted.
- The duration of the abort time can be set via the menu.

Rescue button grinding



In the event of a display failure, grinding can be carried out using the rescue button.

1. Press the rescue button **(22)** with the help of a thin screwdriver or a similar tool.
The grinder starts the grinding process.
2. End the grinding process by no longer pressing and holding the rescue button.

Changing the type of espresso beans

1. Lock the bean hopper **(1)** by pushing in the slider **(18)**.
2. Grind any espresso beans left in the grinding mechanism until the grinder runs empty.
3. Rotate the bean hopper anticlockwise to release it from the grinder and lift it upwards to remove it from the grinder.
4. Remove the remaining espresso beans from the bean hopper.
5. Remove any excess beans from the bean hopper intake **(2)** (see **Fig. B**).
6. Place the bean hopper onto the bean hopper intake.

When placing the bean hopper on, make sure that you place the nose of the bean hopper into the corresponding recess in the bean hopper intake.

7. Push the bean hopper down into the bean hopper intake and turn the bean hopper clockwise to fix it to the grinder.

If the bean hopper cannot be fixed in place by turning it, it may not be positioned correctly. In this case, align the bean hopper correctly (see step 6) and then try again by pressing it down and turning it (see also the “Troubleshooting” chapter).

8. Pour the new espresso beans into the bean hopper.
9. Open the bean hopper by pulling out the slider.
10. Grind 2–3 shots to remove any residue of the old espresso beans, to warm up the machine and to avoid any fluctuations in the dosage.













Using the main menu

You can use the main menu to call up device data and to change individual settings.



You will find precise instructions on how to use the grinder software in the enclosed software instructions.

Display/navigation symbols

Symbol	Meaning
	“Warning & messages” menu item
	“Statistics” menu item
	“Edit recipes” menu item
	“Service” menu item
	“Settings” menu item
	Leave main menu/submenu
	Confirm selection
	Edit selection
Recipe symbols	Designation
	Bottomless portafilter
	Single portafilter (single shot)
	Double portafilter (double shot)
	Manual grinding

Accessing and leaving the main menu

1. Press the controller **(3)** 2 times to call up the main menu on the display **(14)**.
2. Turn the controller to select the desired menu item (see chapter on “Display/navigation symbols”).
The symbol of the menu item selected will be shown in the centre of the display.
3. To access the desired submenu, confirm your selection by pressing the controller or press the lower button **(20)** (symbol **✕**) to exit the main menu.
4. Turn the controller to select a submenu item and confirm your selection by pressing the controller or press the lower button (symbol **✕**) to leave the submenu.



If you take longer than 4 minutes to make or confirm a selection in the main menu or in a submenu, you will be automatically taken back to the home screen.

Entries that have been selected but not confirmed will not be saved.

Cleaning



CAUTION!

Risk of injury!

When being moved the grinder can fall and cause injury.

- Place the grinder on a stable, flat surface so that it cannot wobble.
 - Ask another person for help if the grinder is too heavy.
-

NOTE!

Risk of short-circuit!

Water entering the grinder can cause a short-circuit.

- Never immerse the grinder in water or any other liquids.
 - Never clean the grinder with a water jet.
 - Ensure that no water or other liquids make their way into the casing.
-

NOTE!

Risk of damage!

Improper handling can cause damage to the grinder.

- Do not use any harsh cleaning products or sharp or metallic cleaning objects such as knives, metal scouring pads or similar. These can scratch the surface.
 - Do not clean the grinder with compressed air (e.g. with a compressed air gun).
 - Do not put the drip tray or the lid of the bean hopper into the dishwasher. The parts are not suitable for this and the colour may fade.
 - Do not lift the grinder by the bean hopper; lift only by the casing and always with both hands.
-

Cleaning the grinder installation surface

1. Switch off the grinder (On/Off switch **(5)** to “0”) and remove the power plug from the socket.
2. Lift the grinder by the casing using both hands and place it onto a clean surface.
3. Clean the surface and the underside of the grinder with a damp cloth and dry the surfaces.
The surfaces must be dry and free of oil and grease.
4. Place the grinder back onto the cleaned surface.

Cleaning the casing

1. Switch off the grinder (On/Off switch **(5)** to “0”) and remove the power plug from the socket.
2. Use a brush to clean the following grinder components:
 - the spout **(13)**,
 - the portafilter intake **(12)**,
 - the start button **(11)**,
 - the portafilter support **(10)**,
 - the screws **(8)** for adjusting the portafilter support (left and right).
3. Pull the collecting tray **(9)** forward and out of the grinder.
Wipe the casing and the collecting tray with a damp cloth as required, but at least once a week.

Cleaning the spout system



The manufacturer recommends using a brush with nylon bristles to clean the spout system.

1. Pull the spout **(13)** downwards out of the lock (see **Fig. H**).
2. Carefully clean the outlet on the grinder casing with a brush.
3. Clean the spout with a damp cloth and then dry it.



Be careful not to damage the surface of the spout. Fine scratches can negatively impact the grinding result, as espresso grinds adhere to the scratches, which can, in turn, lead to fluctuations in dosing amount.

Cleaning the bean hopper



The bean hopper must be cleaned daily to remove any coffee oil residue, as this can have a detrimental effect on the taste.

1. Lock the bean hopper **(1)** by pushing in the slider **(18)**.
2. Grind any espresso beans left in the grinding mechanism until the grinder runs empty.
3. Rotate the bean hopper anticlockwise to release it from the grinder and lift it upwards to remove it from the grinder.
4. Transfer the espresso beans into another container temporarily.
5. Clean the bean hopper inside and out with a damp cloth and then dry it.
6. Remove any excess beans from the bean hopper intake **(2)**.
7. Place the bean hopper onto the bean hopper intake.
When placing the bean hopper on, make sure that you place the nose of the bean hopper into the corresponding recess in the bean hopper intake.
8. Push the bean hopper down slightly into the bean hopper intake and turn the bean hopper clockwise to fix it to the grinder.
9. If the bean hopper cannot be fixed in place by turning it, it may not be positioned correctly. In this case, align the bean hopper correctly (see step 7) and then try again by pressing it down and turning it (see also the “Troubleshooting” chapter).
10. Pour the new espresso beans back into the bean hopper.
11. Open the bean hopper by pulling out the slider.

Cleaning the grinding mechanism with GRINDZ™



- The manufacturer recommends using GRINDZ™ grinder cleaner. For more information about GRINDZ™, visit www.mahlkoenig.de.
- The grinding mechanism should be cleaned every 2–5 days.

1. Lock the bean hopper **(1)** by pushing in the slider **(18)**.
2. Set the grinding degree to “10” (see the section “Setting the grinding degree”).
3. Grind any espresso beans left in the grinding mechanism until the grinder runs empty.
4. Rotate the bean hopper anticlockwise to release it from the grinder and lift it upwards to remove it from the grinder.
5. Pour the grinder cleaner into the grinding mechanism directly from above. Observe the quantities specified by the manufacturer for the grinder cleaner you are using.
6. Remove any excess grinder cleaner from the bean hopper intake **(2)**.
7. Place the bean hopper back onto the bean hopper intake.
When placing the bean hopper on, make sure that you place the nose of the bean hopper into the corresponding recess in the bean hopper intake.
8. Push the bean hopper down into the bean hopper intake and turn the bean hopper clockwise to fix it to the grinder.
9. If the bean hopper cannot be fixed in place by turning it, it may not be positioned correctly. In this case, align the bean hopper correctly (see step 7) and then try again by turning it (see also the “Troubleshooting” chapter).
10. Open the bean hopper by pulling out the slider.
11. Place a bowl beneath the spout **(13)** to catch the grinder cleaner. Press the start button **(11)** to start the grinding process and keep it pressed until the grinder cleaner has been completely ground.
12. Grind about the same quantity of espresso beans as you did grinder cleaner in order to remove leftover cleaning particles.
Set the grinding degree to the desired setting during the grinding process.
13. Dispose of the ground grinder cleaner and the ground espresso beans in the commercial/domestic waste.

Cleaning the grinding mechanism manually



- The grinding mechanism should be cleaned every 2–5 days.
- Manual cleaning is an alternative to cleaning the grinding mechanism with GRINDZ™.
- Wear gloves when cleaning the grinding mechanism manually.
- When cleaning the burrs, the burrs do not have to be removed from the burr carriers.

1. Remove the bean hopper **(1)** from the grinder (see chapter “Cleaning the bean hopper” steps 1–3).
2. Switch off the grinder (On/Off switch **(5)** to “0”) and remove the power plug from the socket.
3. Use a flat-head screwdriver to loosen the two locking screws on the grinder lid (see **Fig. I, 23**) in 1–2 turns.
4. Press the bean hopper intake **(2)** down and turn it anticlockwise as far as it will go.
You can now lift off the grinder lid **(25)**.
5. Use a flat-head screwdriver to loosen the three locking screws **(29)** on the fix burr flange **(32)** in 1–2 turns (see **Fig. J**).
6. Turn the fix burr flange anticlockwise as far as it will go and remove it from the grinding chamber in a parallel motion so that it does not become tilted.
7. Clean the fixed burr **(31)** on the fix burr flange and the rotary burr **(28)** in the grinding chamber with a soft wire brush; use a wire brush for the fine grinders and the screw holes or screw heads.
8. Remove the residual coffee grounds from the grinding chamber using a handheld vacuum cleaner.
9. Place the fix burr flange onto the grinding chamber so that the recess in the flapper **(33)** is freely accessible (see **Fig. K**).
During this step we recommend cleaning the flapper (see “Cleaning the flapper” steps 2–4).
10. Turn the fix burr flange clockwise and tighten the three locking screws using a flat-head screwdriver.
11. Place the grinder lid onto the grinder, turn the bean hopper intake clockwise as far as it will go and tighten the locking screws on the grinder lid.
12. Place the bean hopper onto the grinder (see chapter “Cleaning the bean hopper” steps 7–10).

Cleaning the flapper



The flapper should be cleaned every 2–5 days.

1. Remove the grinder lid **(25)**, proceed as described in chapter “Cleaning the grinding mechanism manually” steps 1–4.
2. Remove the flapper **(33)** from the recess in the grinder.
3. Clean the flapper with lukewarm water and then dry it.
4. Replace the flapper into the recess in the grinder.
5. Place the grinder lid onto the grinder; proceed as described in chapter “Cleaning the grinding mechanism manually” steps 11–12.

Maintenance

Changing the burrs



- The burrs should be changed after grinding around 700 kg of espresso beans.
The weight in kg depends on the grinding degree, the type of espresso beans, the roast and the condition of the burrs.
- Wear gloves when changing out the burrs. The manufacturer recommends using the “tool for changing burrs” when carrying out a changeover (available as an optional accessory).
- After changing the burrs, the manufacturer recommends adjusting the burrs (see the “Adjusting the burrs” chapter) and calibrating the Disc Distance Detector (see “Calibrating the Disc Distance Detector” chapter of the software instructions).

1. Proceed as described in the chapter on “Cleaning the grinding mechanism manually” steps 1–6.
2. Loosen the two screws of the fixed burr **(26)** using a flat-head screwdriver and remove from the fix burr flange **(32)**.
3. Remove the flapper **(33)** from the recess in the grinder and insert the locking tool **(34)** into the grinder to change the burr so that the burr carrier **(30)** is fixed (see **Fig. L**).
4. Loosen the two screws of the rotating burr **(28)** from the burr carrier and remove the burr from the grinding chamber using the removal tool **(35)**. Guide the removal tool into the grinding chamber from above. Place the

recess in the removal tool slightly off-centred beneath the burr. Guide the removal tool into the centre of the burr and remove the burr by lifting it upwards.

5. Remove the residual coffee grounds from the grinding chamber using a handheld vacuum cleaner.
Make sure that the burr carrier is completely clean.
6. Place the new rotary burr on the burr carrier and tighten the two screws using a flat-head screwdriver.
7. Remove the removal tool. Replace the flapper into the recess in the grinder.
8. Clean the fix burr flange and screw holes using a wire brush.
Make sure that the fix burr flange is completely clean.
9. Place the new fixed burr onto the fix burr flange and tighten the two screws using a flat-head screwdriver.
10. Place the fix burr flange onto the grinding chamber; proceed as described in chapter “Cleaning the grinding mechanism manually” steps 9–12.

Adjusting the burrs

1. Remove the grinder lid **(25)**, proceed as described in chapter “Cleaning the grinding mechanism manually” steps 1–4.
2. Remove any excess beans from the grinding chamber.
3. Set the grinding degree slider **(15)** to “0” on the grinding degree scale **(16)**.
4. Push the lock on the adjustment ring **(36)** backwards and remove the adjustment ring **(37)** from the grinder by lifting it up and out (see **Fig. M**).
5. Rotate the burrs by turning the screw of the burr carrier **(30)** using a flat-head screwdriver in a clockwise direction.
Repeat this process several times during the adjustment.
6. Turn the dial zero adjustment **(40)** towards the lowest point on the Vernier scale **(39)**.
If you can hear a grinding noise, the distance between the burrs is at its smallest.
7. Slowly turn the dial zero adjustment towards the highest point on the Vernier scale until you can no longer hear a grinding noise.
The burrs are zeroed in.
8. Place the adjustment ring onto the grinder.

The marking on the intermediate plate (**41, 42**) and the deepest groove of the marking on the adjustment ring (**37, 38**) must lie levelly on top of one another (see **Fig. M** and **N**). Push the adjustment ring lock backwards so that the adjustment ring snaps into the intermediate plate.

9. Place the grinder lid onto the grinder; proceed as described in chapter “Cleaning the grinding mechanism manually” steps 11–12.

Changing the flapper



Change the flapper if it becomes porous, deformed or very dirty.

1. Remove the grinder lid (**25**), proceed as described in chapter “Cleaning the grinding mechanism manually” steps 1–4.
2. Remove the flapper (**33**) from the recess in the grinder and insert the new flapper.
3. Place the grinder lid onto the grinder; proceed as described in chapter “Cleaning the grinding mechanism manually” steps 11–12.

Troubleshooting

Fault	Cause	Remedy
The grinder is not grinding, the display is not lit up.	• The power plug is not plugged into a socket.	→ Insert the power plug into a properly installed socket.
	• The bean hopper is not inserted.	→ Insert the bean hopper (see chapter “Setting up the grinder and inserting the bean container”).
	• The overcurrent protection switch was triggered.	→ Check whether the circuit breaker’s release button has popped out. Push it back in if necessary. If the switch continues to pop out, contact your service partner (see the section “Maintenance and service”).
	• The electrical fuse has tripped.	→ Check the electrical fuse. Bring it back to its original state or swap it. Check whether other loads are connected to this fuse and if so, pull their plugs. If the back-up fuse trips repeatedly, contact your service partner (see chapter “Maintenance and service”).

Fault	Cause	Remedy
The grinder is humming but not grinding.	<ul style="list-style-type: none"> • The grinding mechanism is clogged. 	<ul style="list-style-type: none"> → Release the lock on the grind adjustment and set the grinding degree to “10”. Start the grinding process. The grinder clears itself. Then set the grind adjustment to the setting required during operation.
	<ul style="list-style-type: none"> • Ground coffee has built up in the grinder because of too much coffee in the portafilter. 	<ul style="list-style-type: none"> → Clean the spout system (see chapter “Cleaning the spout system”). Release the lock on the grind adjustment and set the grinding degree to “10”. Start the grinding process. The grinder clears itself. Then set the grind adjustment to the setting required during operation.
	<ul style="list-style-type: none"> • The grinding degree is too fine. 	<ul style="list-style-type: none"> → Release the lock on the grind adjustment and set the grinding degree to “10”. Start the grinding process. The grinder clears itself. Then set the grind adjustment to the setting required during operation.
	<ul style="list-style-type: none"> • A foreign object is in the grinding mechanism. 	<ul style="list-style-type: none"> → Clean the grinding mechanism as described in the “Cleaning” section and remove the foreign object as you do so. If the foreign object cannot be removed, contact your service partner (see the section “Maintenance and service”).
The grinder is not grinding fine enough.	<ul style="list-style-type: none"> • The burrs are worn out or require readjustment. 	<ul style="list-style-type: none"> → Clean/change the burrs or zero in the burrs (see “Cleaning/changing the burrs”; “Zeroing in the burrs”).

Fault	Cause	Remedy
The grinder does not grind continuously or the grinding process stops intermittently.	<ul style="list-style-type: none"> • The start button is faulty. 	<ul style="list-style-type: none"> → Contact your service partner (see the section “Maintenance and service”).
The grinder’s dispensing accuracy is decreasing.	<ul style="list-style-type: none"> • The spout is clogged. Too much ground coffee has been deposited in solid form inside the grinder. • The grinder spout is damaged. • The flapper is dirty. • The flapper is faulty. 	<ul style="list-style-type: none"> → Remove the spout or clean the spout from the outside with a brush with the grinder switched off. Release the lock on the grind adjustment and set the grinding degree to “10”. Start the grinding process. The grinder clears itself. Then set the grind adjustment to the setting required during operation. → Contact your service partner (see the section “Maintenance and service”). → Clean the flapper (see “Cleaning the flapper”). → Change the flapper (see “Changing the flapper”).
The bean hopper cannot be attached.	<ul style="list-style-type: none"> • There are beans in the bean hopper intake. 	<ul style="list-style-type: none"> → Remove the beans from the bean hopper intake.
The grinder lid cannot be attached.	<ul style="list-style-type: none"> • The fix burr flange is not installed correctly. • The adjustment ring is not installed correctly. 	<ul style="list-style-type: none"> → Align the fix burr flange correctly (see “Cleaning the burrs”). → Align the adjustment ring correctly (see “Zeroing in the grinding degree”).

Fault	Cause	Remedy
The grinder does not deposit the grounds into the centre of the inserted portafilter.	<ul style="list-style-type: none"><li data-bbox="302 143 504 279">• The spout is not correctly aligned with the portafilter.	→ Align the spout correctly with the portafilter used.

Technical data

Model:	E80S
Voltage/frequency:	100 V; 50/60 Hz 110–127 V; 60 Hz 220–240 V; 50/60 Hz
Protection type:	IPX1
Protection class:	I ⊕
Fuse:	16 A-slow/15 A
Idle speed:	
50 Hz:	1 400 rpm
60 Hz:	1 700 rpm
Sound emission value (during grinding):	70 dBA
Grinding output (fine–coarse):	6–8 g/s*
Max. permitted operating cycle:	
100 V; 50/60 Hz:	10 double espressos/min. (3 seconds on / 3 seconds off)
110–127 V; 60 Hz:	10 double espressos/min. (3 seconds on / 3 seconds off)
220–240 V; 50/60 Hz:	10 double espressos/min. (3 seconds on / 3 seconds off)
Recommended pause:	3 seconds
Max. grinding time:	10 min continuous grinding
Max. daily output:	90 kg
Dimensions (W × D × H):	233 × 340 × 630 mm
Weight (net):	15 kg
Max. funnel filling quantity:	1.8 kg

*depending on the espresso bean type, the grinding degree selected and the mains frequency.

Disposal

Disposing of the packaging



Dispose of the packaging by correctly sorting the recyclable materials. Dispose of card and cardboard as waste paper, and film as recyclable materials.

Disposing of the grinder



Old appliances may not be thrown into the commercial/domestic waste!

If you can no longer use your grinder, you are **legally obliged as a user to dispose of old appliances separately from commercial/domestic waste**, e.g. at a collection point in your community/district. Then it can be ensured that old appliances are recycled professionally and negative impacts on the environment are avoided. For this reason, electrical appliances are labelled with the symbol opposite.

Maintenance and service

In the event of service or maintenance, contact an Authorised Service Centre for Mahlkönig products. Customer Service can answer your questions about repairing and maintaining your product and spare parts.

Enlarged diagrams and information on spare parts are also available at:

www.mahlkoenig.de

www.mahlkoenig.de/retailers



Our application consulting team will be happy to help you with questions concerning our products and their accessories.

For all enquiries and spare parts orders, please be sure to include the article and serial number as stated on the grinder type plate.

The version of the grinder is displayed in the service menu.

Mention your supplier when calling for service.

HEMRO

Global Coffee Grinding Solutions

Hemro International AG

Länggenstrasse 34 | 8184 Bachenbülach, Switzerland

T: +41 44 864 18 00 | F: +41 44 864 18 01

info@hemrogroup.com | www.hemrogroup.com