

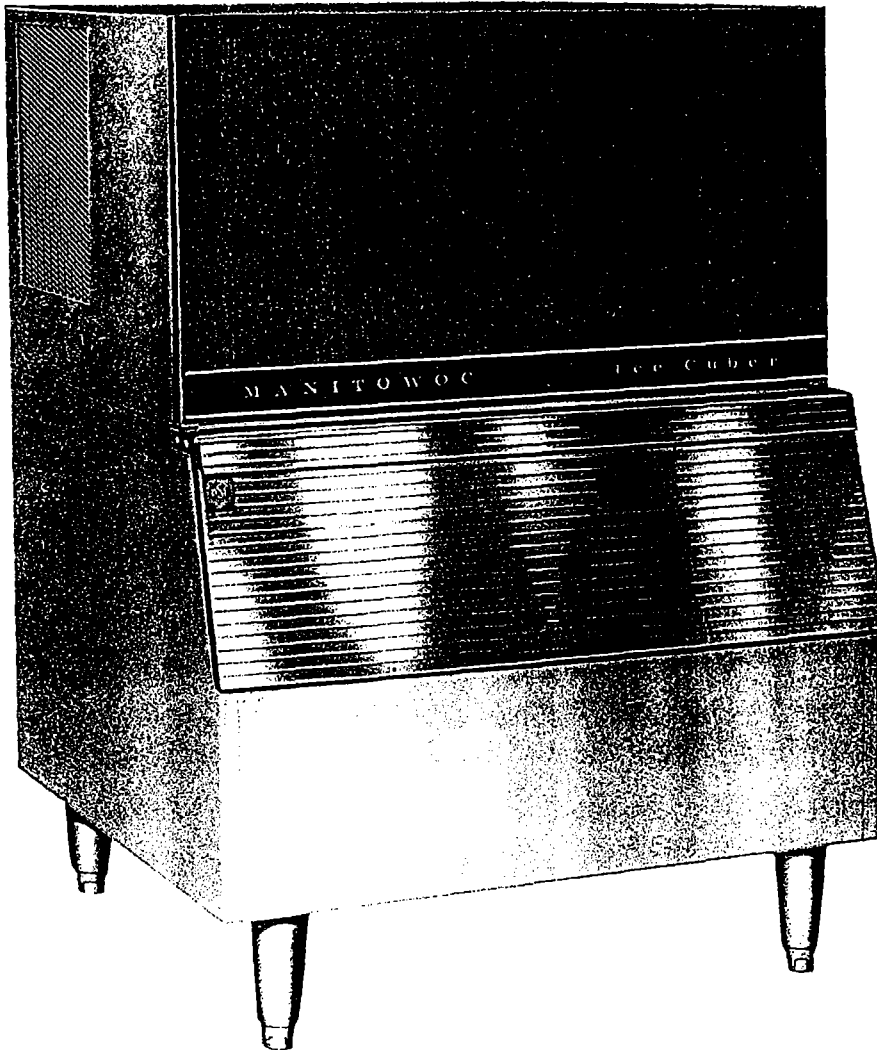

# Manitowoc

## AD & AR 150 SERIES ICE CUBER SERVICE MANUAL



**Manitowoc equipment works**

**MANITOWOC  
WISCONSIN**

Division of The Manitowoc Company, Inc.

TABLE OF CONTENTS

Uncrating and Inspection .....	Page 2
Location .....	Page 2
Setting Up Cabinet .....	Page 2
Serial and Electrical Plate .....	Page 2
Removing Front Panel .....	Page 2
Removing Head Section Panels .....	Page 2
Electrical Connections .....	Page 2
General Requirements .....	Page 2
Connecting Power Supply .....	Page 2
Water Supply .....	Page 2
Connecting Water Supply .....	Page 2
Drain Connections .....	Page 2
Check List for Starting Machine .....	Page 3
Controls .....	Page 3
Setting Timer .....	Page 3
Fig. 1 – Front with Panel Removed .....	Page 5
Fig. 2 – Front with Splash Curtain Removed .....	Page 6
Fig. 3 – Condensing Unit Section .....	Page 7
Fig. 4 – A150 Series Head Section .....	Page 8
Fig. 5 – General Specifications .....	Page 9
Fig. 6 – Cabinet and Bin .....	Page 10
Fig. 7 – Water System Sketch .....	Page 11
Fig. 8 – Timer .....	Page 12
Fig. 9 – Side View .....	Page 13
Fig. 10 – Top View .....	Page 14
Service Analysis .....	Page 15
Specifications – 60 Cycle .....	Page 16
Cleaning Instructions .....	Page 17
Wiring Diagram (81-0424-1) .....	Page 18
Wiring Diagram (81-0419-1) .....	Page 19
Parts List .....	Page 20
Service and Parts Procedure .....	Page 20
Warranty .....	Page 22

## FORWARD

Manitowoc Equipment Works, Division of the Manitowoc Company, Inc., Manitowoc, Wisconsin, presents this Service Manual to assist the service man with information concerning CONSTRUCTION, INSTALLATION, and MAINTENANCE of the MANITOWOC ICE MAKER.

The problems of the user and the service man have been given special emphasis in the development of the latest MANITOWOC Ice Machines.

If you encounter a problem which is not answered by this manual, please feel free to write or call the Service Department of the Manitowoc Equipment Works, Division of The Manitowoc Company, Inc., Manitowoc, Wisconsin, describing the problem you have encountered. The Service Department will be happy to give you particularized advice and assistance. Whenever calling or writing, please state the complete model and serial number of the ice making equipment.

MANITOWOC EQUIPMENT WORKS  
Div. of THE MANITOWOC CO., INC.  
Manitowoc, Wisconsin 54220

## MODELS

This manual includes the following models:

- AR-0150A – Regular Cube, Air Cooled
- AR-0151W – Regular Cube, Water Cooled
- AD-0152A – Dice Cube, Air Cooled
- AD-0153W – Dice Cube, Water Cooled

**UNCRATING AND INSPECTION**

All AR and AD 150 Series Ice Cubers and Bins are shipped in separate corrugated cartons. To uncrate remove the staples around the lower edge of the carton, lift the carton upwards and off, and inspect for concealed damage. Machine section is held to the skid by two bolts. Remove these skid bolts and set the machine on the bin.

**LOCATION**

Some models are designed to slide under a 42 inch bar or any other convenient location. For maximum efficiency, pick a location away from sources of heat like radiators, ovens, other refrigeration condensing units, direct sunlight, etc. Provide space around the cabinet for air circulation. Air cooled models require a minimum of 3 inches at any louvered opening to the compressor compartment. Cabinets located in unheated areas must be protected from freezing or shut down and drained. When machine is in place, remove wooden wedges under compressor. These were placed there for shipping purposes.

**SETTING UP CABINET**

Uncrate bin and inspect for concealed damage. Screw the legs in the four holes in bottom of bin. Carefully set bin in place and level, by adjusting the levelers built into each leg. In the event that installation is such that legs can't be used, screw out the four legs and use shims to level the cabinet. The National Sanitation Foundation Requires that a cabinet not on legs must be sealed to the floor using mastic around the entire perimeter of the bottom of the bin.

**SERIAL AND ELECTRICAL PLATE**

The combined serial and electrical plate is located in the upper right corner inside front of cabinet. Be sure to send the complete serial number (14 numbers) and the model number when calling for service or parts.

**REMOVING FRONT PANEL**

To remove front panel, (Fig. 6 "J") pull forward on lower edge of panel and lift panel up and off. To install panel, set top of panel on edge at the top of head unit and snap into place at bottom

**REMOVING HEAD SECTION PANELS**

The top and both sides of the cuber head unit is a one-piece construction. To remove this wrap-around panel, remove the three screws (Fig. 6 "L") along the lower edge and the two screws (Fig. 6 "K") on the back edge on each side of head unit. Lift the entire panel (Fig. 6 "I") forward to remove. This will expose both the ice making and machine section of the cuber.

**ELECTRICAL CONNECTIONS**

115 Volt — 60 Cycle — 1 Phase 15 Ampere Outlet

**GENERAL REQUIREMENTS**

All electrical and water supply and drain connections must conform to local codes.

**CONNECTING POWER SUPPLY**

From rear of cuber place No. 14 separately fused wire into hole (Fig. 6 "B") in back panel. Run wire across machine section and into the hole at lower portion of electrical control box (Fig. 6 "C").

From front of machine remove the cover from electrical control box. Connect lead wires with the two lead wires supplied in control box leading to N (neutral) and L<sub>2</sub> (line 2). Use No. 15 Ampere Fusetrons only, as all 60 cycle circuits are 115 volt, necessitating a neutral in the supply line.

**WATER SUPPLY**

Quality and ice making capacity are affected more by chemistry, temperature, and foreign matter in supply water than any other factor. A survey made of water departments of large cities all over the country made it obvious that external filters or strainers should be installed. Such equipment is very effective in improving ice quality and reducing the frequency of cleaning out the ice making sections.

**CONNECTING WATER SUPPLY**

A ½" female pipe fitting is provided on the back of the head unit. (Fig. 6 "D") Install the water filter screen provided with the cabinet. Use 3/8" O.D. copper tubing for the water supply.

**DRAIN CONNECTIONS**

It is essential that drain connections be made so waste water can't back up into the head unit or bin. On water cooled models, a separate connection is provided for discharging condenser water. (Fig. 6 "E"). All connections are labeled. We recommend covering all incoming water and drain lines with a plumbing insulation material to prevent condensation. If the head unit and bin drains are tied together through a "T" connection, we recommend using a 3/4" pipe and a stand pipe vented to the atmosphere to prevent water traps. Drains must be at least 1/2" inside diameter and have 1½" drop per 5 feet of run. If drains are not close enough to allow drop for proper drainage, or water is to be drained in a stationary sink higher than ice machine drains, use an automatic condensate disposal pump. (Check and follow local plumbing codes.)

**CHECK LIST FOR STARTING MACHINE**

Remove tape securing the damper door, splash curtain and float valve. (Fig. 1 "A")

Remove and discard screw securing the water pump mounting bracket to the cabinet wall. Raise the pump enough to remove the packing protecting the pump during shipment. Fig. 1 "B". Remove shipping block (Fig. 3 "E").

Turn on water, and observe that the float valve shuts off the water when the level is about 2 inches deep. Should float require adjustment merely bend float rod carefully until desired water level is achieved. Turn the toggle switch to "water pump", left position.

The water pump will start pumping water into the tube located at the top of the evaporator. Return water will flow into the sump.

#### CHECK FOR THE FOLLOWING THINGS

A higher than necessary water level wastes water and reduces ice making capacity.

Turn the machine on and off several times to flush clean water through the system and to observe that waste water drains properly.

With the toggle switch in the "ICE" position, reach down and push the damper door open. The entire machine should stop and remain off until the damper is released.

The installer should replace the panel on the head unit, put the front panel in place, and check the first harvest of cubes to see that the machine functions properly.

The ice size controls consist of a Ranco or Penn reverse-acting pressure control (opens on pressure rise) and a Paragon time clock. These controls are factory set and should need no adjustment except in altitudes above 5,000 feet.

#### MANITOWOC'S FREEZE AND HARVEST CONTROL FOR 150 SERIES MODELS AR & AD

Freeze and harvest cycles on the above model Manitowoc Cubers are regulated by three very simple controls. The basic control is a low side reverse-acting pressure regulator made by either Ranco or Penn. This is mounted in the compressor compartment at the upper edge of the bulk head which separates this area from the freezing section. The second control is a Paragon Timer, located in the control panel of the freezing compartment. The third is a thermo disc installed on the suction line outlet of the evaporator. On starting a warm machine, the suction pressure may be upwards of 75 PSIG; but as the compressor runs, the suction pressure and temperature within the line is lowered. When the line temperature reaches 35 degrees F., the thermo disc "cuts in" and closes the clutch on the timer and holds it "in" continuously through the freezing cycle. When the suction pressure reaches 12 lbs. in the regular cube unit (14 lbs. in the dice cube unit), the pressure control electrically activates the timer motor. The cam on the timer motor is set at approximately 4½. This is equal to 6½ minutes running time. The clock continues to run until the cam stalls against the harvest micro switch. This places the unit in harvest, and it will stay in harvest until released by the bin damper switch when the sheet of ice falls into the bin. The thermo disc remains closed during the entire harvest cycle. It opens only when the temperature of the suction lines rises to 65 degrees. This is a safety measure to prevent overheating in case the unit would stay in harvest.

If the dimple in the cubes is too pronounced, you may set the timer dial to 5. This will increase the freezing time. Likewise, if the bridging between cubes is too heavy, you may set the dial back to about 4. This shortens the freezing time.

#### CONTROLS

##### High Pressure Cut-Out

This shuts entire machine off, should the head pressure exceed 275 PSIG. (Water cooled only)

##### Suction Line Thermo Disc

Suction line thermo disc is a safety control located on suction line. This control is a Klixon switch that opens at 65°F + -5° and closes at 35°F + -5°. The thermo disc acts only as a safety device to prevent overheating of the machine. Should the damper door switch fail after harvest, the thermo disc will open. Then the suction line temperature reaches 65° + -5° this will return the machine to its normal freezing cycle by disengaging the clock clutch located on the clock.

##### Toggle Switch

The main power "ON and OFF" toggle switch is a double pole, double throw switch with "OFF" in the center position. With the toggle switch in the "water pump" (Left) position, only the water pump and the condenser fan operate. This is for checking the water inlet float level, pump operation, and for circulating cleaning solution.

With the toggle switch in the "ICE" (Right) position, the water pump, compressor and condenser fan (air cooled models), run for a normal ice making cycle.

##### Ranco or Penn Pressure Control

This control is a reverse-acting pressure control that opens on pressure rise. Upon decrease in suction pressure ( 12 lbs. dice cube, 14 lbs. regular cube), the pressure control closes, actuating the time clock.

##### Paragon Time Clock

After the pressure control energizes the time clock, the time clock motor turns a cam for 6½ minutes (number 4½ on time clock face). When the 6½ minutes have elapsed, the cam trips a micro switch which in turn cycles the machine into hot gas or harvest cycle. Simultaneously, the water pump (and condenser fan on air cooled models) are shut off. Harvest will last approximately 1½ to 2 minutes.

##### Damper Door Switch

When the harvest is completed, the ice falls through the damper door tripping the damper door switch. This, in turn, opens the holding clutch on the time clock momentarily to reset the clock and return the machine to its normal freeze cycle.

When the ice bin is full, the ice holds the bin switch open keeping the machine shut off.

Should the damper switch fail, the suction line thermo disc will open to reset the time clock.

#### SETTING TIMER

Should it be necessary to adjust the timer for an accurate bridge thickness, proceed as follows:

1. Remove cover from the control box Fig. 1 "C".
2. Locate timer Fig. 2 "A".

3. Loosen adjustment screw, Fig. 8 "D".
4. To decrease bridge thickness, set arrow Fig. 8 "C" to number 3. Likewise to increase bridge thickness, set arrow to number 5.
5. Retighten set screw.
6. On models with solid state timer, set dial to desired setting.

#### EVAPORATORS

NOTE – The regular cube evaporator is larger than the dice cube. Be sure to use correct part number should replacement parts be required.

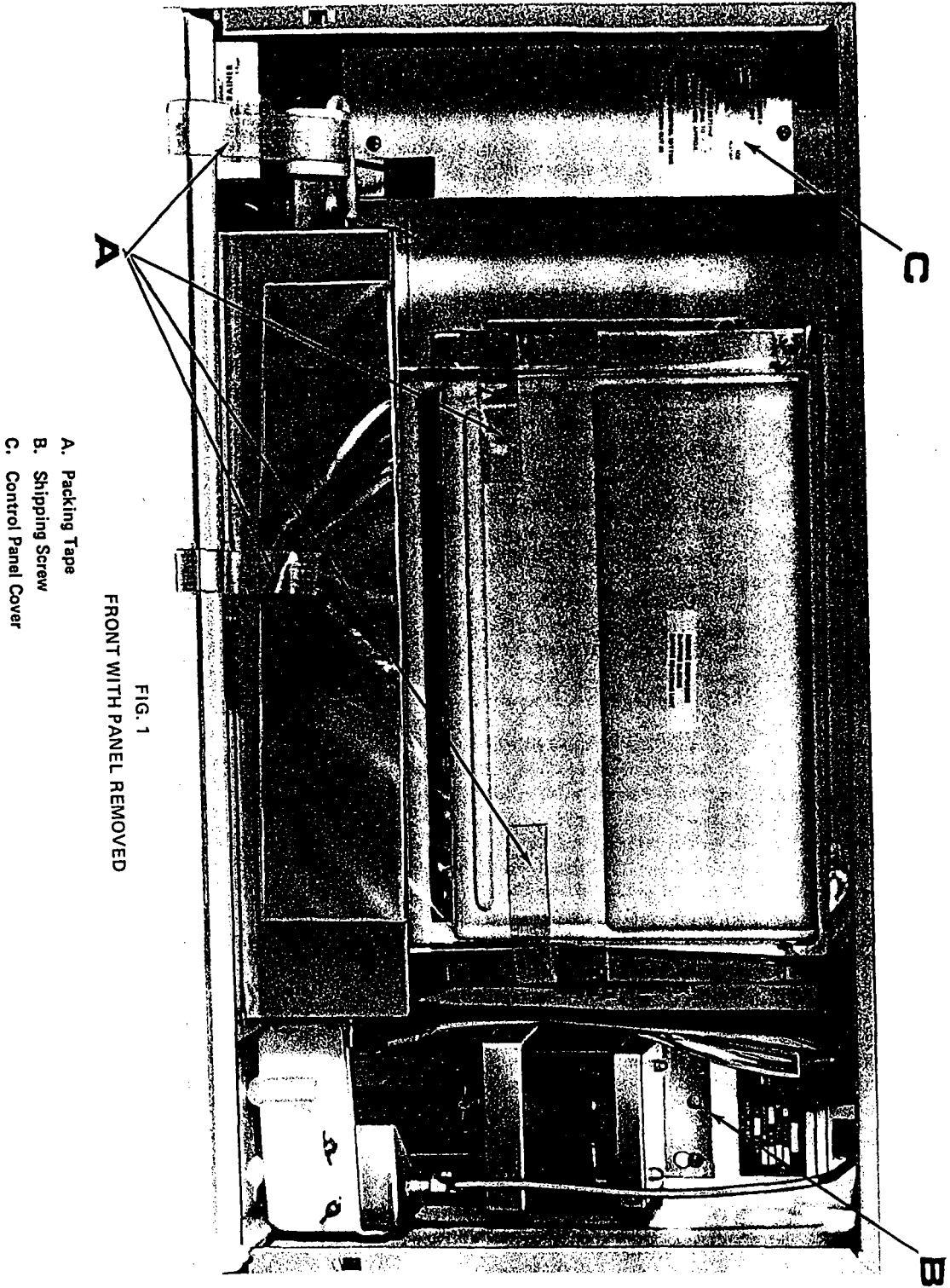

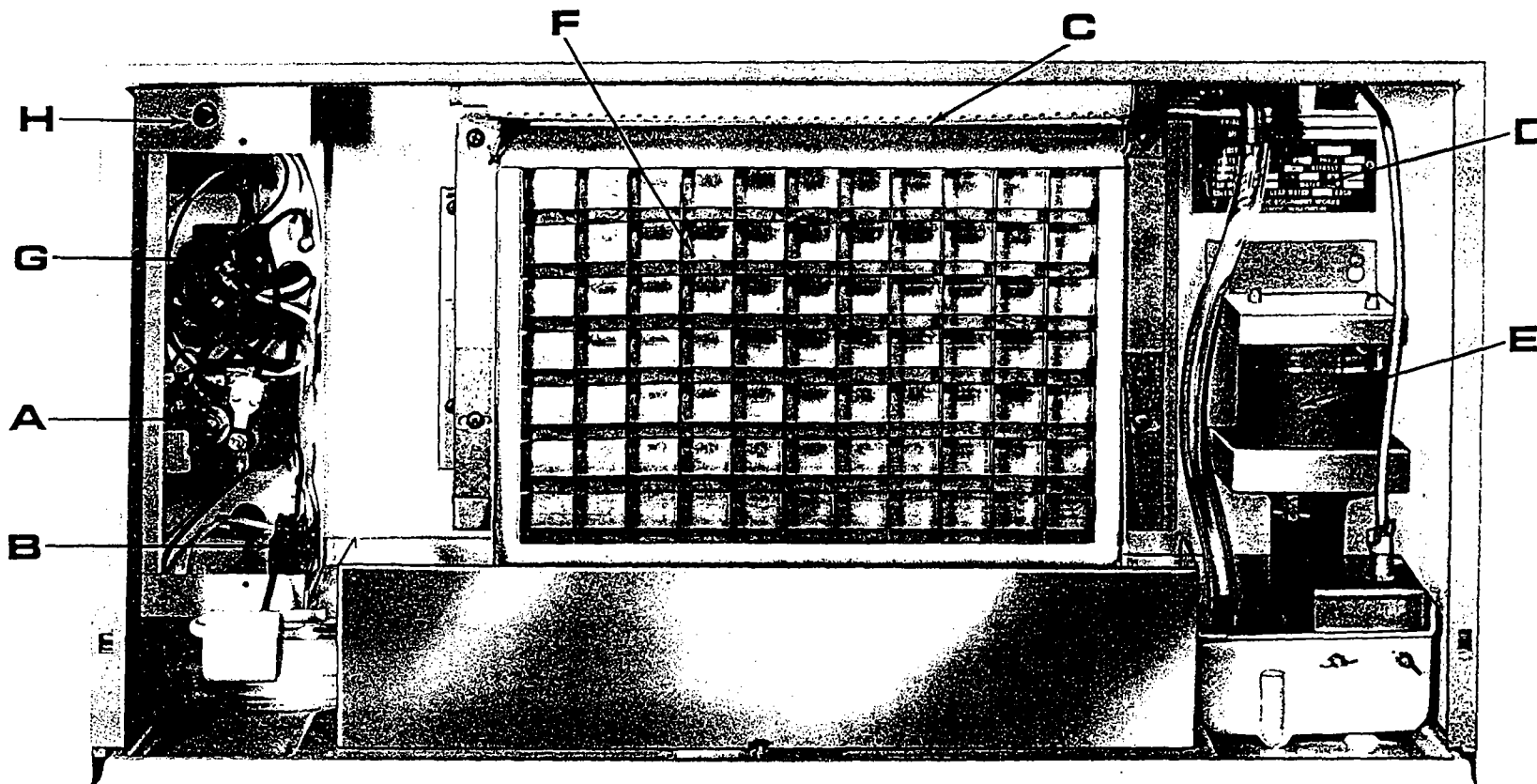

- A. Timer
- B. Bin Switch
- C. Water Distributor
- D. Serial Plate

FIG. 2  
FRONT WITH SPLASH CURTAIN REMOVED

- E. Water Pump
- F. Evaporator
- G. Terminal Board
- H. Toggle Switch

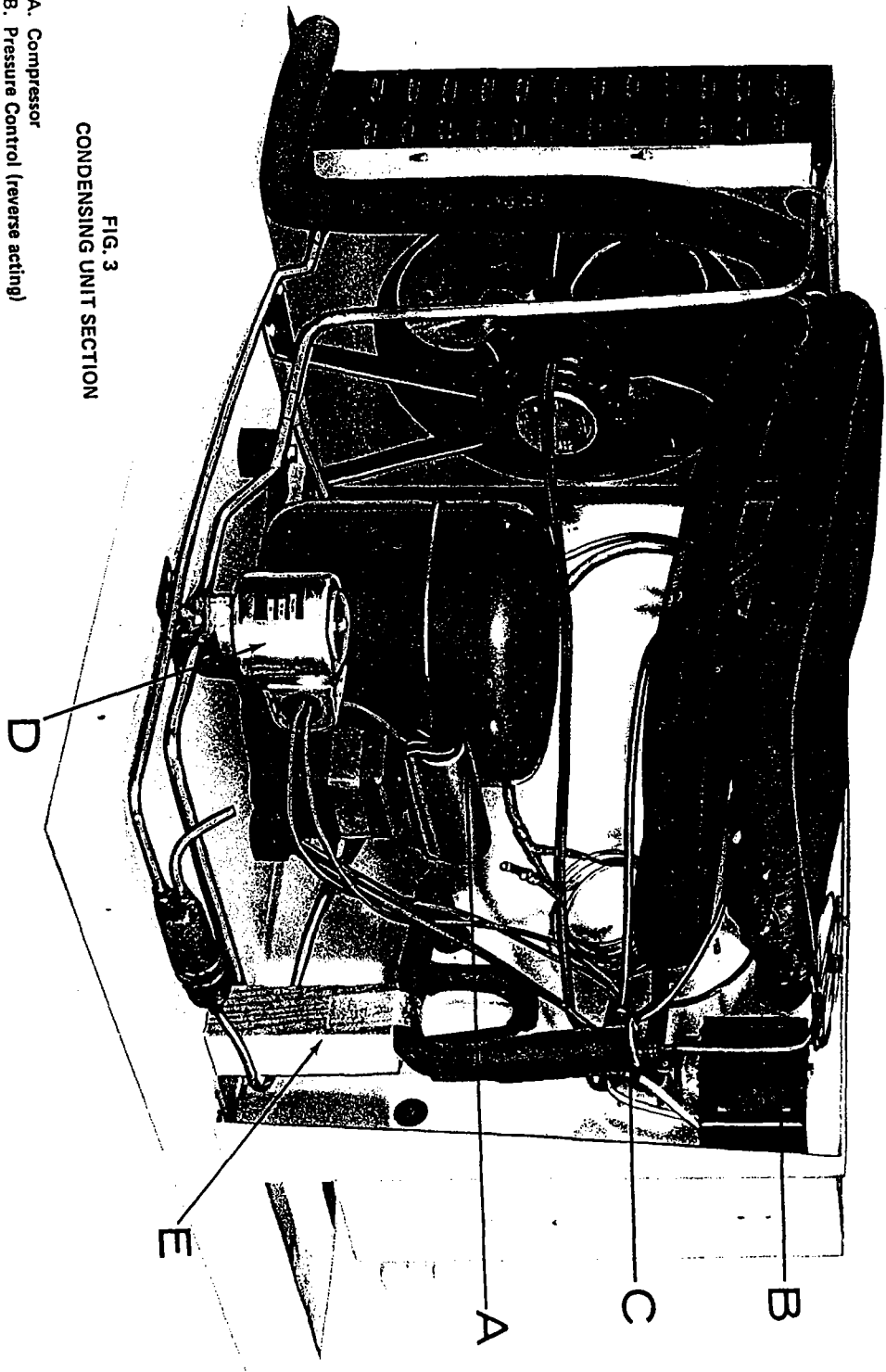
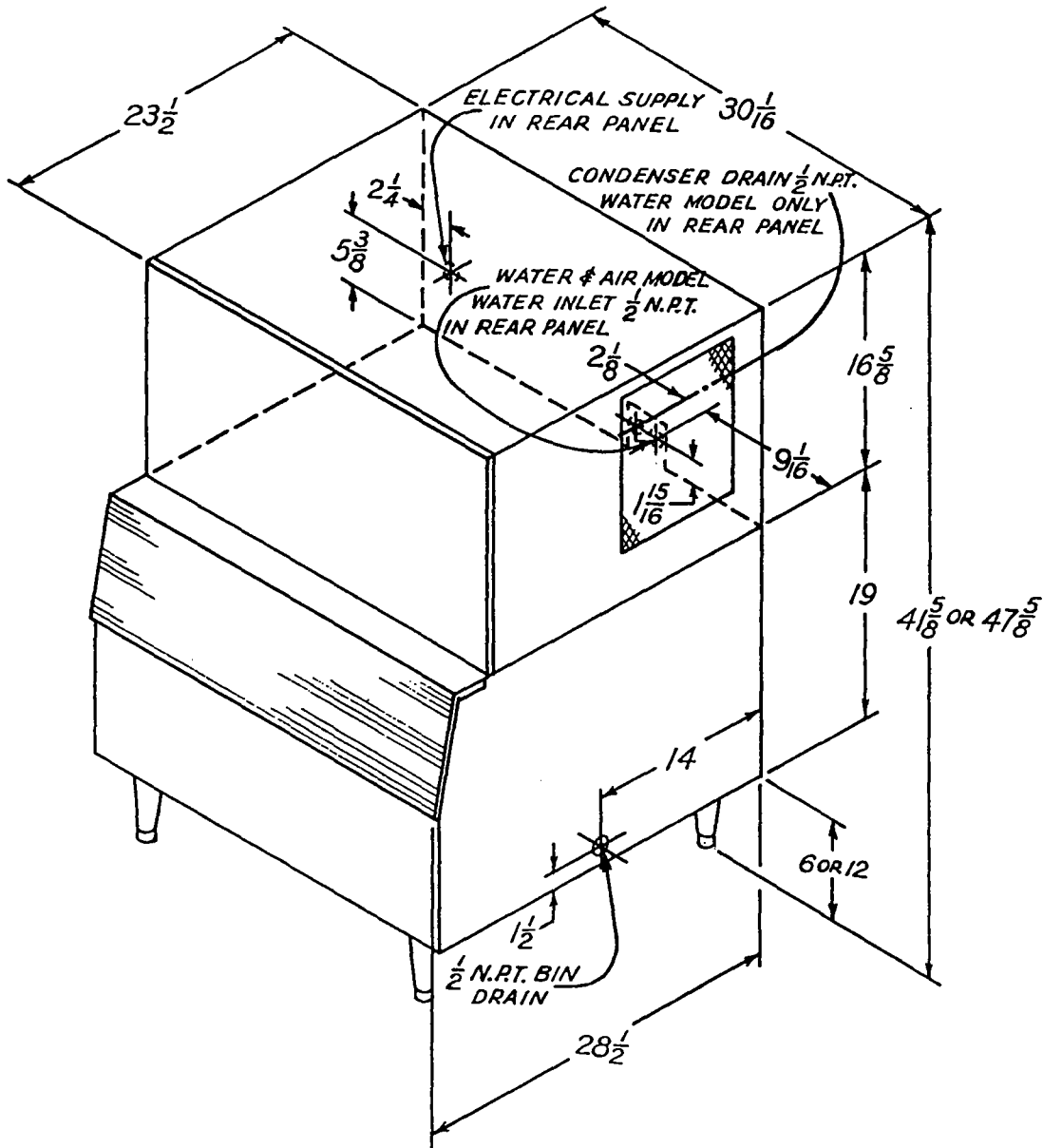

FIG. 3  
CONDENSING UNIT SECTION

- A. Compressor
- B. Pressure Control (reverse acting)
- C. Expansion Valve
- D. Solenoid Valve
- E. Shipping Block

MANITOWOC – A150 SERIES HEAD SECTION



A150 SERIES HEAD SECTION  
 C-170 BIN  
 606 LEGS

FIG. 4

**MANITOWOC A-150 SERIES HEAD SECTION  
GENERAL SPECIFICATIONS**

**ICE PRODUCTION – lbs. per 24 hours**

<b>AR-0150A Regular Cube – Air Cooled</b>			
<b>WATER TEMP. °F.</b>	<b>AIR TEMPERATURE °F.</b>		
	<b>70</b>	<b>80</b>	<b>90</b>
50	165	135	115
70	150	125	105
90	135	115	100
<b>AR-0151W Regular Cube – Water Cooled</b>			
50	150	140	130
70	135	125	115
90	130	120	110
<b>AD-0152A Dice Cube – Air Cooled</b>			
50	165	135	115
70	150	125	105
90	135	115	100
<b>AD-0153W Dice Cube – Water Cooled</b>			
50	150	140	130
70	135	125	115
90	130	120	110

Height	41-5/8"
Height with 6" Legs	47-5/8"
Width	30-1/16"
Depth	23-1/2"
Depth with C-170 Bin	28-1/2"
Depth with C-400 Bin	34"
Depth with C-610 Bin	29-9/32"
Approximate Shipping Weight	180 lbs.
Compressor	1/3 H.P.
Elec. Characteristics	115-60 Cy Single Phase AC
Finish	Fawn Baked Enamel Front Panel Walnut Grained Vinyl

FIG. 5

FIG. 6  
CABINET AND BIN

- A. Back Panel
- B. Power Supply Inlet
- C. Control Box
- D. Water Inlet 1/2 N.P.T.
- E. Condenser Water Outlet (Water Cooled Only) 1/2 N.P.T.
- F. Bin
- G. Drain (Bin)
- H. Bin Legs
- I. Outer Panel
- J. Front Panel
- K. Back Panel Screw Holes
- L. Bottom Screw Holes

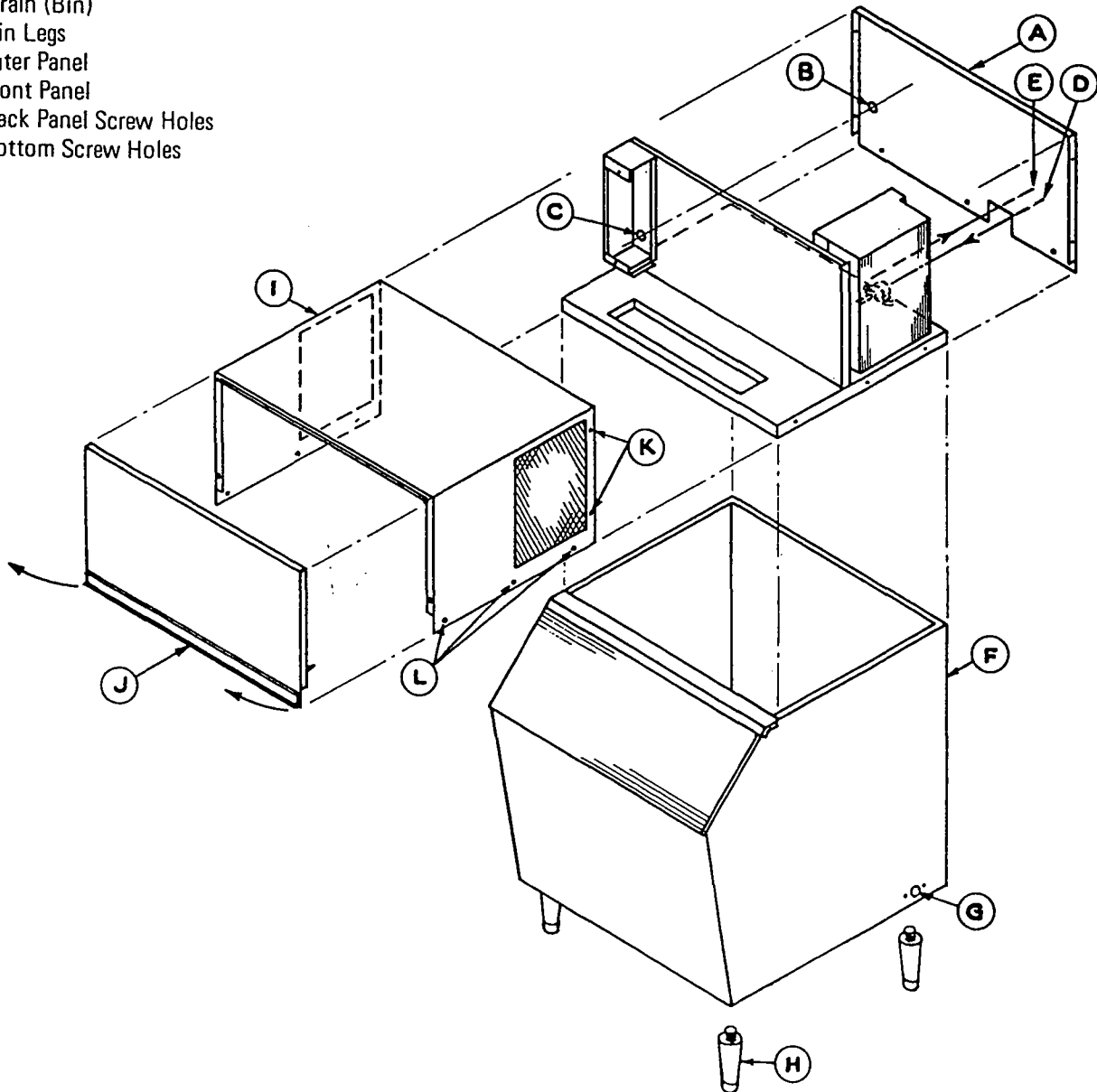

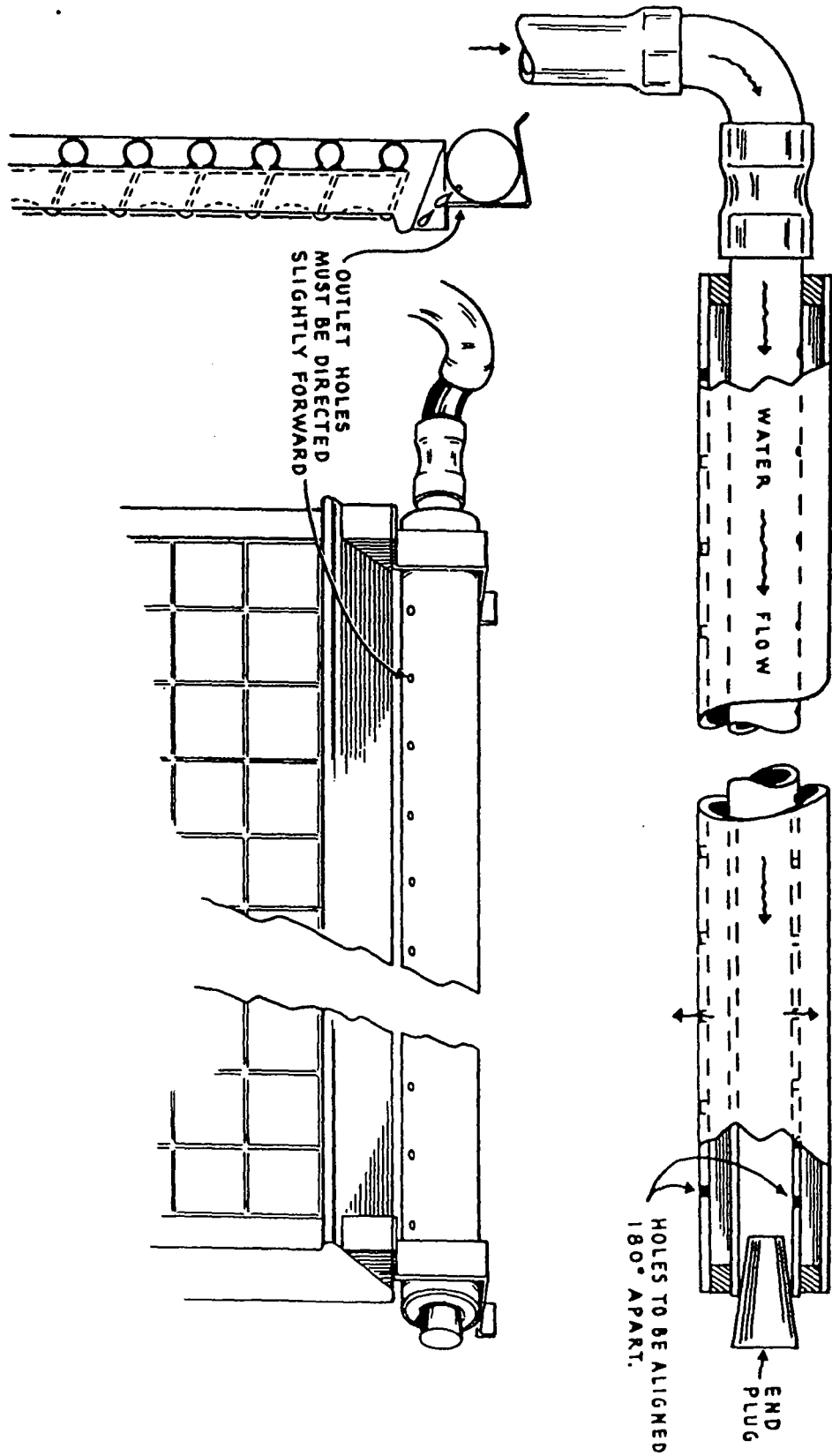

Water System Sketch

FIG. 7

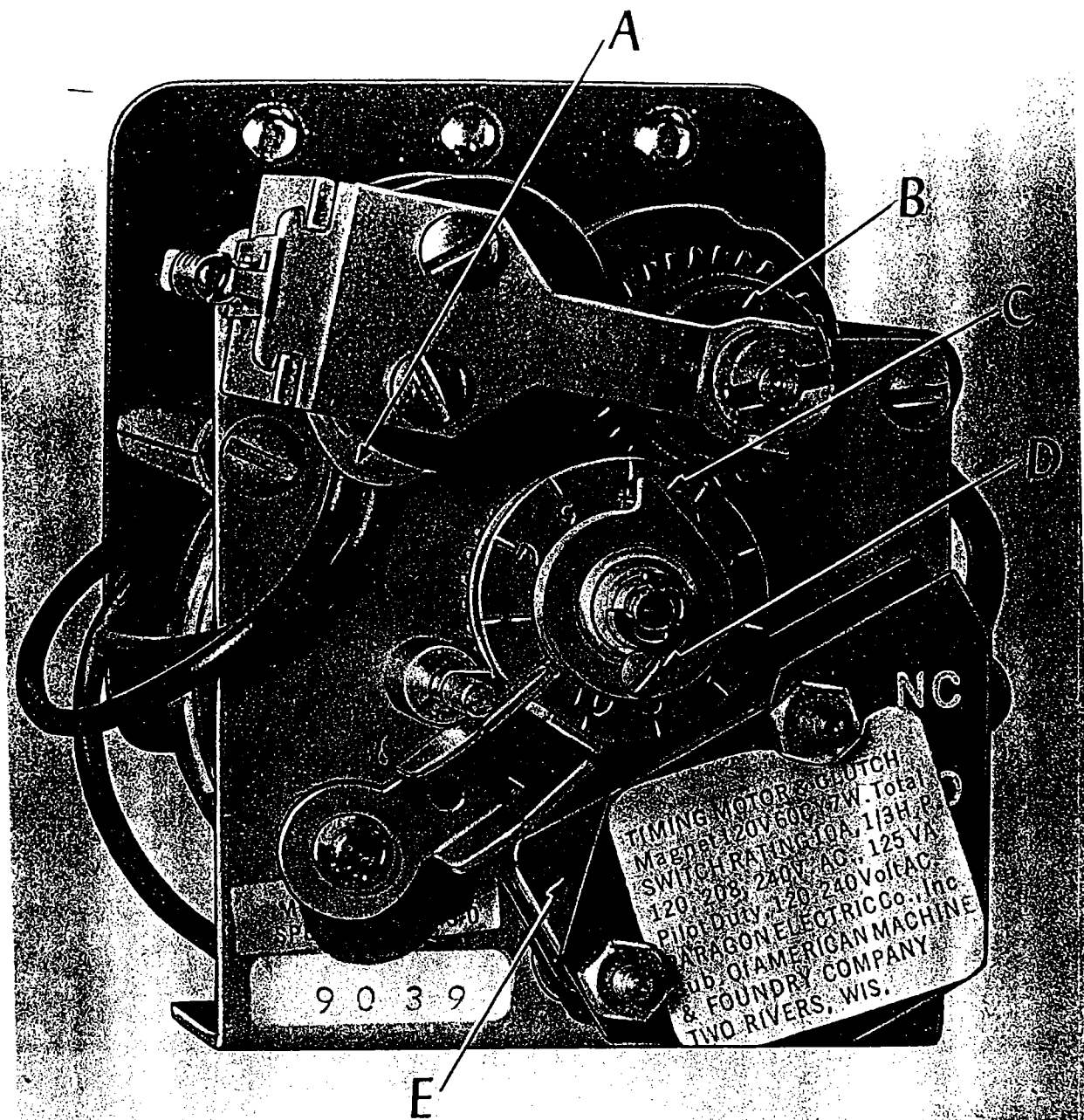

FIG. 8

- A. Clutch Coil
- B. Clutch
- C. Timer Setting
- D. Timer Setting Lock Screw
- E. Micro Switch

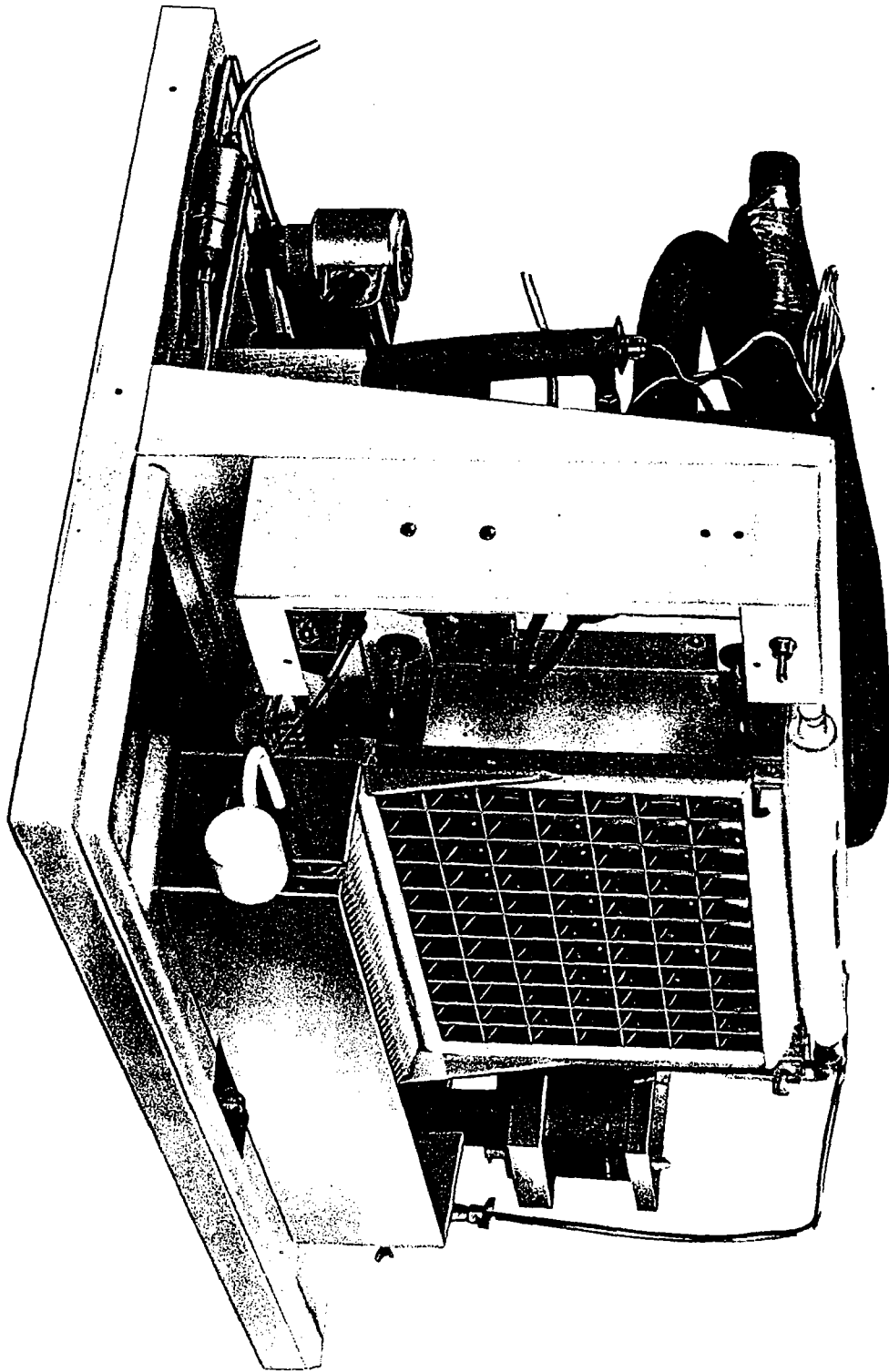

FIG. 9  
SIDE VIEW

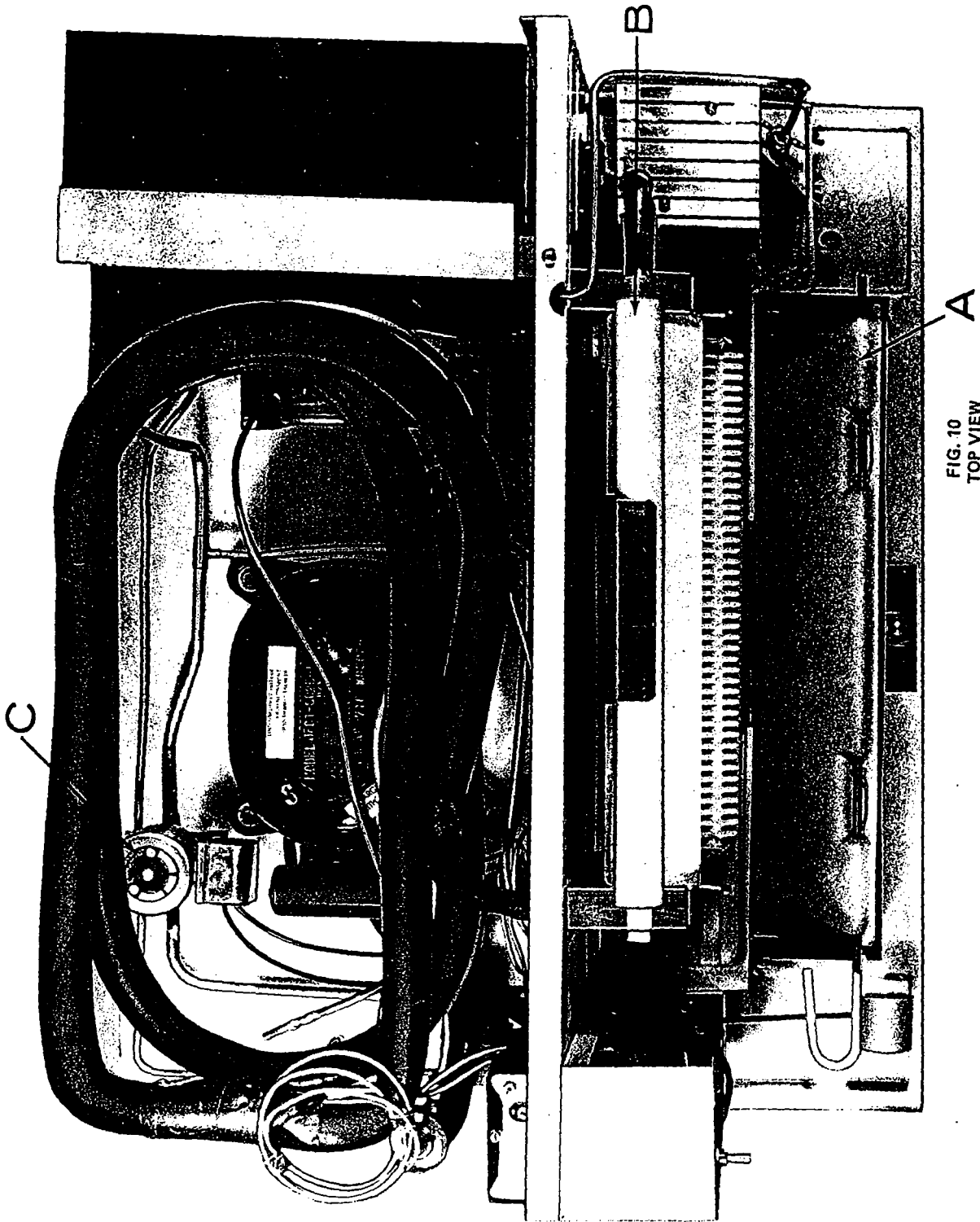

FIG. 10  
TOP VIEW

- A. Damper Door
- B. Water Distributor
- C. Solenoid Valve

## SERVICE ANALYSIS

COMPLAINT	CAUSE	CORRECTIVE MEASURES
Slow harvest	Contaminated or limed water system Low ambient (air cooled models) Water valve set too low  Leaking water valve (water cooled models)	Clean water system Must be above 50° F. Adjust water valve to 125 PSIG head pressure Replace water valve
High head pressure	Air in system Defective water valve (water cooled models) Defective fan (air cooled models) Water valve not properly adjusted Contaminated air cooled condenser Defective expansion valve	Evacuate and recharge Replace water valve  Replace fan Adjust water valve Clean condenser Replace
High suction pressure	Contaminated condenser Defective fan Defective water valve (water cooled models) Moisture in system	Clean Replace fan Replace or adjust water valve  Replace drier, evacuate, and recharge
Low suction pressure	Shortage of refrigerant Moisture in system Ambient too low for operation	Locate leak and repair Replace drier, evacuate system Must be above 50° F.
Unit noisy	Fan shroud touching fan blades	Adjust fan mounting brackets
Ice maker will not stop when full of ice	Damper door not properly adjusted Defective damper door micro switch	Adjust damper door Replace damper door micro switch
Time clock will not operate	Ranco pressure control not closing	Replace control
Time clock will not actuate harvest	Timer micro defective Thermo disc is not closed	Replace micro switch Check thermo disc
Small cube bridge	Ranco pressure control not opening Leak in refrigeration system	Replace control Locate leak, repair, evacuate, and recharge
Machine will not cycle into harvest	Defective time clock clutch coil Defective time clock micro switch Defective thermo disc or thermo disc loose on suction line	Replace Replace, or tighten on suction line

60 CYCLE

CUBER MODEL	AR & AD 150 SERIES WATER COOLED			AR & AD 150 SERIES AIR COOLED		
	70	90	110	70	90	110
Compressor Model						
Compressor Voltage						
Winding Resistance Common to Run						
Winding Resistance Common to Start						
Start Capacitor Rating						
Fan Motor Model						
Fan Motor Amps						
Fan Motor Watts						
Fan Motor Volts						
Fan Winding Resistance						
Solenoid Valve Volts						
Solenoid Valve Winding Resistance						
Hartell Water Pump Winding Resistance						
Hartell Water Pump Amperage						
Refrigerant Charge – R-12						
Normal machine amperage						
Room Temperature	70	90	110	70	90	110
HEAD Maximum	125	125	125	102	140	180 PSIG
PRESSURE Minimum	125	125	125	84	120	160 PSIG
SUCTION Maximum	21	22	22	19	22	26 PSIG
PRESSURE Minimum	12	13	13	11	12	12 PSIG

## CLEANING INSTRUCTIONS

### IN PLACE CLEANING

To clean the ice cuber water system without removing the components proceed as follows: NOTE – This is only recommended in locations where impurity build-up is not heavy.

1. Remove ice cuber front panel.
2. Shut off ice cuber.
3. Remove ice from bin.
4. Shut off water supply and remove water from water sump.
5. Pour one bottle of ice machine cleaner into sump and turn supply water on.
6. Place toggle switch to water pump position and circulate cleaner for about 30 minutes.
7. After cleaning shut machine off and remove cleaner. Flush water system thoroughly.
8. Clean ice storage bin with ice machine cleaner also.

### DISASSEMBLING WATER SYSTEM FOR CLEANING

To clean parts by removing proceed as follows:

1. Shut machine off.
2. Remove splash curtain, water pump and water distributor.
3. Disassemble distributor as indicated in Fig. 7.
4. Disassemble water pump as follows:
  - A. Turn pump over and remove the 6 brass thumb screws.

- B. Hold and depress impeller. Rotate plastic thumb nut counter-clockwise.

- C. Remove screws and pump housing. Pump is now ready for cleaning.

- D. Reassemble in reverse order as removed.

Scrub all parts removed using a nylon scouring pad, brushes, and a cleaning solution such as LIME-A-WAY from Economics Laboratory, Inc., Calgon Ice Machine Cleaner, or Boss Brand Milk Stone Cleaner from Northern Laboratories. Rinse all parts with clear water.

It is recommended that the ice be removed from the storage bin before scrubbing the base and evaporator assembly. Rinse with clear water. Check to see that overflow or drain hole in the base is clear and that water drains through freely.

Reassemble unit. To sanitize unit, mix ONE TEASPOON OF SODIUM HYPOCHLORITE IN ONE GALLON OF WATER. Pour solution into sump, then turn toggle switch to the left to start water pump.

Keep pouring solution into sump until system has enough to keep pump primed. After one minute, turn off pump and remove solution from water sump. Repeat with clear water before turning switch back to the ice making position. Make visual inspection for leaks and operation before replacing the front panel.

AR AND AD 0150 SERIES  
AIR AND WATER  
FAN ON AIR COOLED ONLY  
SHOWN AT BEGINNING OF  
FREEZE CYCLE  
115 VOLT, 60 CY.

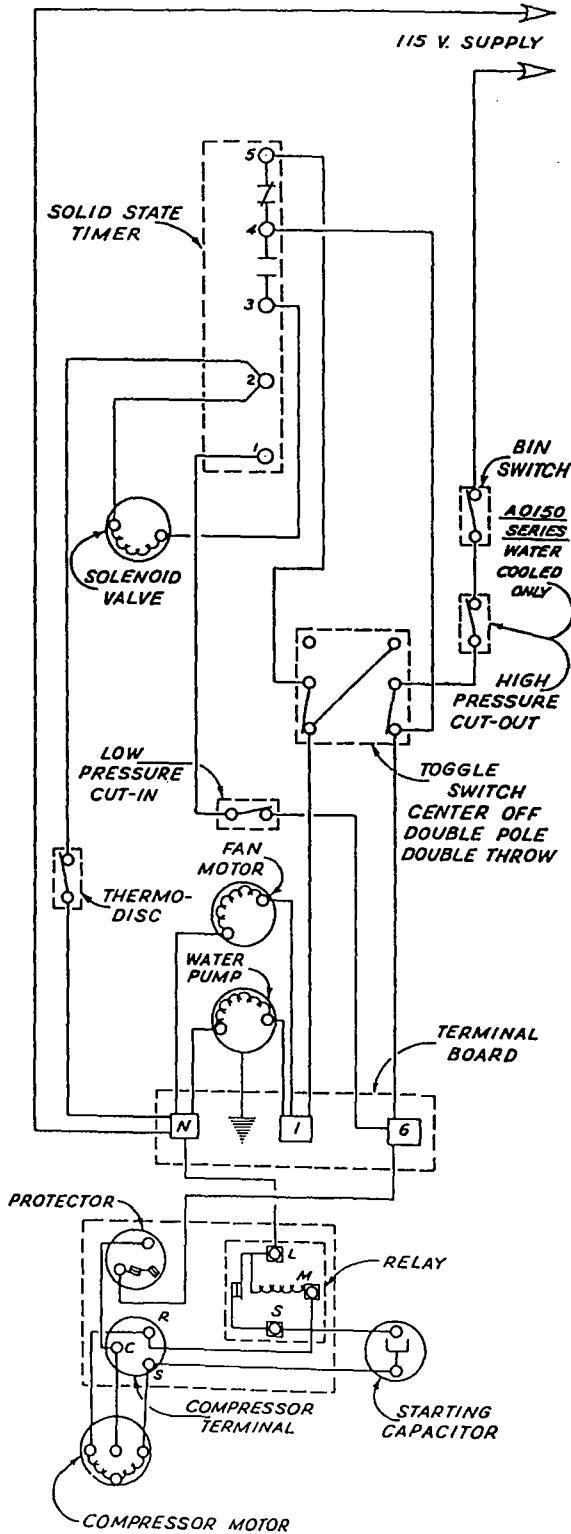

AR & AD 150 SERIES  
AIR & WATER  
FAN ON AIR COOLED ONLY  
SHOWN AT BEGINNING OF  
FREEZE CYCLE

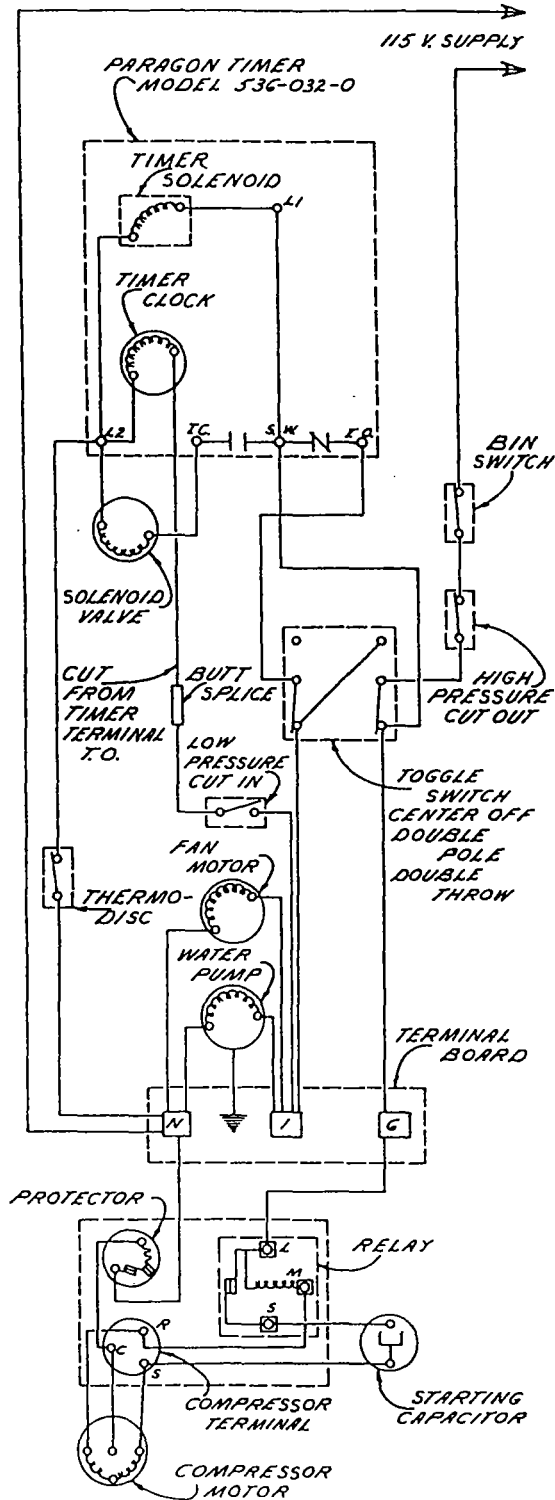

BASIC PARTS LIST	PART NUMBER
Compressor .....	14-0016-1
Relay .....	15-0292-1
Overload .....	15-0291-1
Start Capacitor .....	15-0275-1
Condenser (Air Cooled) .....	11-5016-1
Condenser (Water Cooled) .....	11-6502-1
Fan Motor .....	24-0221-1
Fan Blade .....	24-0015-1
Expansion Valve .....	13-6702-1
Solenoid Valve .....	24-0218-1
Thermo Disc .....	23-5086-1
Timer (Paragon) .....	24-0217-1
Bin Switch .....	23-0079-1
Toggle Switch .....	23-0056-1
Ranco Pressure Control .....	23-5079-1
High Pressure Cut-out .....	23-5501-1
Water Distributor (Regular Cube) .....	C15144-1
Water Distributor (Dice Cube) .....	C15143-1
Water Pump Assembly .....	14-8023-1
Float Assembly .....	13-6902-1

**SERVICE AND PARTS PROCEDURES**

**Order and Pricing Procedure**

All replacements parts for the Manitowoc ice machine equipment are to be ordered directly from the factory; however, any distributors or dealers who may be interested in stocking replacements parts for the machines they sell, in order to provide their customers with a prompt and efficient service, may purchase these parts with the understanding that, any time they feel they have parts they no longer need or feel they no longer want to carry replacement parts, they are to notify the factory's Parts Department as to which parts they wish to return.

Upon receipt of this listing, we will immediately send them written authorization to return these parts; and upon receipt of these parts, full credit will be issued. There will be no charge for restocking these parts. Of course, credit can only be issued if the parts are returned in a new and unused condition.

When placing your order, be sure to do as follows:

1. Print name and address plainly.
2. If special routing is requested, please show the name of the carrier.
3. Indicate quantity desired, print catalogue part number plainly and print name as shown in the catalogue.
4. Indicate model and serial number of the unit. The complete serial number is needed.

5. If uncertain as to the proper part number, please give a complete description or sketch of the part and the location of the part which is needed.

6. Check to see that all required information is contained in your order to facilitate prompt shipment. All replacement parts are shipped from the factory on a f.o.b. Manitowoc basis. It is company policy to bill for all field replacement parts, according to terms as specified by our Credit Department.

All parts orders will be honored by the factory and will be billed according to our parts list schedules.

Parts which are covered by our warranty policy are to be returned to the factory for credit properly packaged, transportation charges prepaid. Upon receipt of these parts here at the factory, they will be inspected; and if they are found to be defective, in material and workmanship, under normal use and service, credit will be issued. Parts not properly packaged will be returned to the sender freight collect.

Transportation companies are responsible for damage in transit as all shipments are tendered to them in good condition; and our responsibility ceases upon receipt of a signed bill of lading from the carrier. If the shipment arrives in a damaged condition or is short, the delivery carrier should be notified immediately.

**Return of Defective Parts**

All defective parts returned to the factory, transportation prepaid, must be properly packaged to prevent further damage and tagged with a return material tag properly filled in. It is especially important that the cabinet serial number be secured and recorded on the tag, securing as much information as possible about the nature of the defect to prevent any delays in issuing credit. All parts should be returned as they are removed from the cabinet and not mutilated or tampered with. The return material tags are provided on a no-charge basis by the factory upon receipt of your request. Any part not properly packaged will be returned to the sender freight collect and no credit will be issued.

Our warranty and protection plan does not apply to cabinets that are not registered; therefore, it is necessary that, upon completion of the installation of the cabinet, the registration card be signed on the date of installation and mailed promptly to the factory Service Department in order for the cabinet to be registered.

**Return of Hermetically-sealed Units**

Extreme care should be used in servicing the hermetically-sealed mechanism. It is important that the trouble be correctly determined before the unit is changed. Be sure it is not the control, relay, or overload causing the trouble. The defect must be listed on the return material tag. Hermetically-sealed units must be returned with service valves closed and capped. All lines must be pinched and soldered shut.

**Return of Complete Machines**

No complete machines may be shipped back to the factory for repairs without first securing prior permission from the factory. If an unauthorized shipment is received at the factory, it will be refused by our warehouse and immediately returned to the sender. Upon receipt of your request to return a cabinet, if we feel that your request is legitimate, you will be sent an authorized return label authorizing you to return this cabinet to the factory freight prepaid.

# Ice Machine and Bin Warranty

From the date of original installation, we do hereby warrant each new Ice Machine and Bin to be free from defects in material and workmanship, under normal use and service, for a period of one year, and four additional years on the hermetic motor compressor in the Ice Machine.

Our obligation under this warranty is limited solely to correcting or replacing without charge at the factory in Manitowoc, Wisconsin any part or parts of this equipment which shall have been returned, transportation prepaid, and which our examination discloses to our satisfaction to be defective.

This warranty does not apply to any equipment that has been damaged by flood, fire, or suffered abuse, misuse, neglect or accident, or to any Ice Machine which has been altered so as to affect performance or reliability, except where such alteration has been accomplished with our prior written consent.

We further limit this warranty in that we shall not be held liable under this contract for any special, indirect, or consequential damages whatsoever resulting from any defect in material and workmanship which interferes with the normal use and service of such Ice Machine and Bin.

This warranty is a complete and exclusive statement of all terms of the agreement between the Manitowoc Equipment Works and the owner of the equipment, and all representations of the parties. This agreement shall not be varied, supplemented, qualified or interpreted by any prior course of dealing between the parties or by any usage of the trade.

Sales are made on the express understanding that there are no express or implied warranties other than the express warranty herein contained and that there are no implied warranties that the goods shall be merchantable or fit for a particular purpose other than the expressed one year and five year warranty set forth above.

To validate this warranty, the registration card must be signed on the date of installation and mailed promptly to the Manitowoc Equipment Works, Manitowoc, Wisconsin.

DEALER \_\_\_\_\_  
\_\_\_\_\_  
\_\_\_\_\_

INSTALLATION DATE \_\_\_\_\_

**MANITOWOC EQUIPMENT WORKS**  
Div. of THE MANITOWOC COMPANY  
500 South 16th Street  
Manitowoc, Wisconsin 54220