

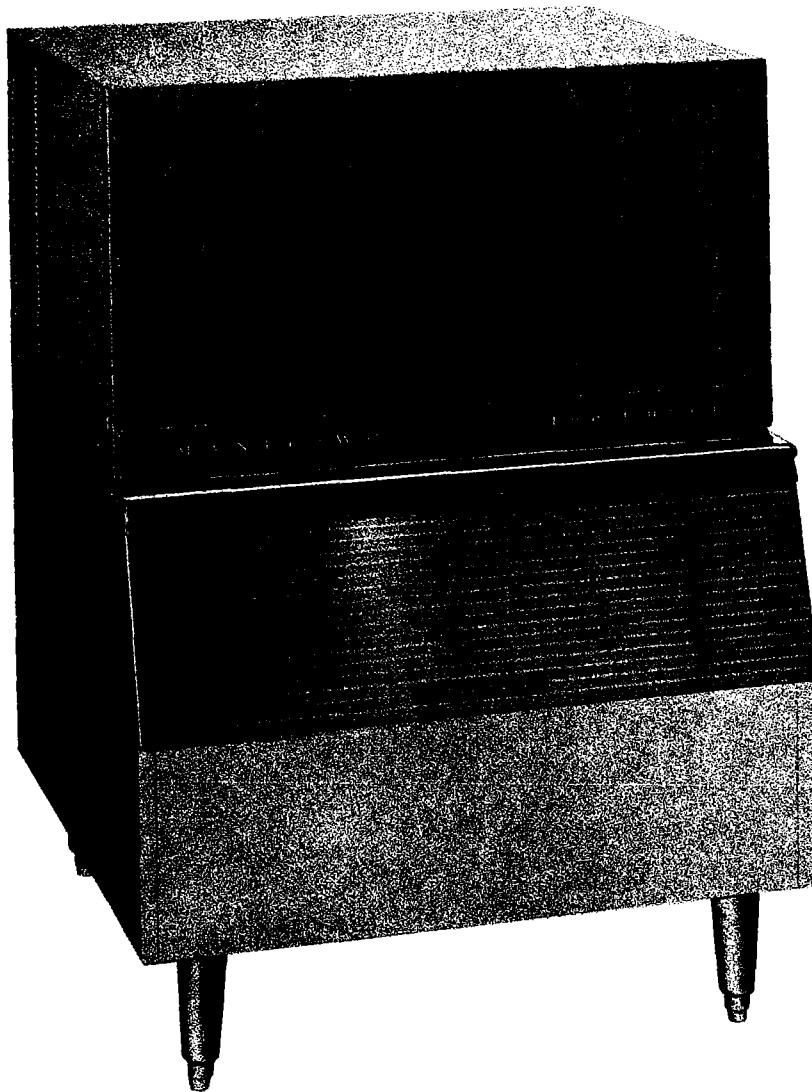

# Manitowoc

## AD, AR & AY 200 SERIES ICE CUBER SERVICE MANUAL



**Manitowoc** equipment works

Division of The Manitowoc Company, Inc.

MANITOWOC  
WISCONSIN

80-0039-1  
August 1978

**TABLE OF CONTENTS**

|  |            |
|--|------------|
| Forward .....  | Page 1     |
| Inspection and Uncrating .....                       | Page 2     |
| Location .....                                       | Page 2     |
| Setting Up Cabinet .....                             | Page 2     |
| Serial and Electrical Plate .....                    | Page 3     |
| Removing Front Panel .....                           | Page 3     |
| Removing Head Section Panels .....                   | Page 3     |
| Electrical Connections .....                         | Page 3     |
| General Requirements .....                           | Page 3     |
| Connecting Power Supply .....                        | Page 3     |
| Water Supply .....                                   | Page 3     |
| Connecting Water Supply .....                        | Page 3     |
| Drain Connections .....                              | Page 3     |
| Check List for Starting Machine .....                | Page 4     |
| System Control and Sequence of Operation .....       | Page 4     |
| Controls .....                                       | Page 5     |
| Solid State Timer and Adjustment .....               | Page 6     |
| Fig. 1 — 60 Cy. Wiring Diagram .....                 | Page 7     |
| Fig. 2 — 50 Cy. Wiring Diagram .....                 | Page 8     |
| Fig. 3 — Ice Making Compartment .....                | Page 9     |
| Fig. 4 — Control Box .....                           | Page 10    |
| Fig. 5 — Compressor Compartment (Air Cooled) .....   | Page 11    |
| Fig. 6 — Compressor Compartment (Water Cooled) ..... | Page 12    |
| Fig. 7 — Water System Sketch .....                   | Page 13    |
| Fig. 8 — General Specifications .....                | Page 14    |
| Component & Operating Characteristics .....          | Page 15    |
| Service Analysis .....                               | Page 16-17 |
| Cleaning Instructions .....                          | Page 18    |
| Service and Parts Procedure .....                    | Page 19    |
| Warranty .....                                       | Page 20    |

**FORWARD**

Manitowoc Equipment Works, Division of The Manitowoc Company, Inc., Manitowoc, Wisconsin, presents this Service Manual to assist the service man with information concerning CONSTRUCTION, INSTALLATION, and MAINTENANCE of the MANITOWOC ICE MAKER.

The problems of the user and the service man have been given special emphasis in the development of the latest MANITOWOC Ice Machines.

If you encounter a problem which is not answered by this manual, please feel free to write or call the Service Department of the Manitowoc Equipment Works, Division of The Manitowoc Company, Inc., Manitowoc, Wisconsin, describing the problem you have encountered. The Service Department will be happy to give you particularized advice and assistance. Whenever calling or writing, please state the complete model and serial number of the ice making equipment.

**MANITOWOC EQUIPMENT WORKS**  
Div. of **THE MANITOWOC CO., INC.**  
Manitowoc, Wisconsin 54220  
(414) 682-0161

**MODELS**

This manual includes the following models:

- AR-0200A — Regular Cube, Air Cooled
- AR-0201W — Regular Cube, Water Cooled
- AD-0202A — Dice Cube, Air Cooled
- AD-0203W — Dice Cube, Water Cooled
- AD-0204A — Half Dice, Air Cooled
- AD-0205W — Half Dice, Water Cooled

**WARRANTY**

|                    |                         |
|--------------------|-------------------------|
| Parts and Material | One year — parts only   |
| Compressor         | Five years — parts only |

Defective parts must be returned transportation prepaid.

(See "Ice Machine and Bin Warranty" page 20 and registration card shipped with the unit for warranty conditions.)

**FOR YOUR PROTECTION**

The carrier who delivers this merchandise to your door is responsible for loss and damages. Acceptance of this shipment by the transportation company is acknowledgment that the articles delivered to them were in good condition and properly packed. It is your responsibility to file a claim with the carrier if any of the following condition exist.

**A. VISIBLE DAMAGE**

1. If cartons appear damaged in any form, please open at once in presence of driver.
2. Have deliveryman note on freight bill the nature and extent of damages.
3. Notify the transportation company's office to inspect the merchandise.
4. File claim for damages at once. In filing a claim with the transportation company, you may elect to:
  - (A) Make a cash adjustment for full value,
  - (B) Arrange to have repairs made, or
  - (C) Replace the merchandise.

**B. CONCEALED DAMAGE**

1. If damage is noticed when merchandise is unpacked, notify the transportation company's office immediately and ask to have it inspected.
2. Do not destroy packing materials until shipment is inspected.
3. Unless these conditions are met, it is very difficult to file claim against a transportation company.

**C. SHORTAGES**

1. Check number of cartons delivered with the quantity shown on your receipt.
2. If quantities do not tally, have driver note shortage and file your claim with them.

**IMPORTANT**

All claims for loss and damage should be filed immediately with the transportation company making delivery to your door.

We are willing to assist you in every possible manner in collecting claims for loss or damage on this shipment, but this willingness on our part does not make us responsible for filing or collecting claims, or replacing merchandise.

Under no circumstances will we accept the return of any merchandise unless written permission has been given by our service department.

**UNCRATING AND INSPECTION**

All Series 200 ice cubers are shipped in corrugated cartons. To uncrate remove the staples around the lower edge of the carton, lift the carton upwards and off, and inspect for concealed damage. Machine section is held to the skid by two bolts. Remove these skid bolts and set the machine in place. When machine is in place carefully level cabinet.

**LOCATION**

Some models are designed to slide under a 42 inch bar or any other convenient location. For maximum efficiency, pick a location away from sources of heat like radiators, ovens, other refrigeration condensing units, direct sunlight, etc. Provide space around the cabinet for air circulation. Air cooled models require a minimum of 5 inches at any louvered opening to the compressor compartment. Cabinets located in unheated areas must be protected from freezing or shut down and drained. When machine is in place, remove wooden wedges under compressor. These were placed there for shipping purposes.

**SETTING UP ICE BIN**

Separate instruction sheet shipped with bins.

## SERIAL AND ELECTRICAL PLATE

The combined serial and electrical plate is located inside the cabinet on the partition panel above the water pump. Be sure to send the complete serial number and the model number when calling for service or parts. On early models serial and electrical plate is located on outside right end panel.

## REMOVING FRONT PANEL

To remove front panel, pull forward on lower edge of panel and lift up and off. To install panel, set top of panel on edge at the top of head unit and snap into place at bottom.

## REMOVING HEAD SECTION PANELS

The top and both sides of the cuber head unit is a one-piece construction. To remove this wrap-around panel, remove the three screws along the lower edge and the two screws on the back edge on each side of head unit. Lift the entire panel forward to remove. This will expose both the ice making and machine section of the cuber.

## ELECTRICAL CONNECTIONS

115 Volt — 60 Cycle — 1 Phase.

Maximum fuse size: 15 Amps.

Minimum ampacity rating: 13.4 Amps.

## GENERAL REQUIREMENTS

All electrical and water supply and drain connections must conform to all local and national codes.

## CONNECTING POWER SUPPLY

Your cuber should be connected to a separately fused circuit. Fuse size must not exceed maximum fuse size shown on the electrical plate.

All electrical wiring connected to your cuber must be rated equal to the minimum ampacity shown on the electrical plate.

From rear of cuber place separately fused conduit enclosed wire into hole (Fig. 8) in back panel. Run conduit and wire across machine section and into the hole at lower portion of electrical box (Fig. 5).

From front of machine remove the cover from electrical control box. Connect lead wires with the two lead wires supplied in control box leading to N (Neutral) and L<sub>2</sub> (Line 2).

## WATER SUPPLY

Quality and ice making capacity are affected more by chemistry, temperature, and foreign matter in supply water than any other factor. A survey made of water departments of large cities all over the country made it obvious that external filters or strainers should be installed. Such equipment is very effective in improving ice quality and reducing the frequency of cleaning out the ice making sections.

## CONNECTING WATER SUPPLY

A ½" female pipe fitting is provided on the back of the head unit (Fig. 5 & 6). Install the water filter screen provided with the cabinet. Use ¾" O.D. copper tubing for the water supply.

## DRAIN CONNECTIONS

It is essential that drain connections be made so waste water can't back up into the head unit or bin. On water cooled models, a separate connection is provided for discharging condenser water (Fig. 6). All connections are labeled. We recommend covering all incoming water and drain lines with a plumbing insulation material to prevent condensation. If the head unit and bin drains are tied together through a "T" connection, we recommend using a ¾" pipe and a stand pipe vented to the atmosphere to prevent water traps. Drains must be at least ½" inside diameter and have 1½" drop per 5 feet of run. If drains are not close enough to allow drop for proper drainage, or water is to be drained in a stationary sink higher than ice machine drains, use an automatic condensate disposal pump. (Check and follow local plumbing codes.)

### CHECK LIST FOR STARTING MACHINE

Remove tape securing the damper door, splash curtain, water pump, and float valve. Remove the corrugated packing protecting the pump during shipment. Remove compressor shipping block from beneath compressor.

Turn on water, and observe that the float valve shuts off the water when the level is just below the top of the elbow. Should float require adjustment merely bend float rod carefully until desired water level is achieved. Turn the toggle switch to "water pump", left position. The water pump will start pumping water into the water distributor tube located at the top of the evaporator. Return water will flow into the sump. The water level should not overflow the elbow (Fig. 3) while the pump is running.

### FINAL CHECK LIST

1. Is cuber level? (IMPORTANT)
2. Water level in sump trough should be as high as possible so water pump does not suck in air, but too high a water level wastes water and reduces ice making capacity.
3. Turn the ice cuber on and off several times to flush clean water through the system and to observe that waste water drains properly.
4. Check water distributor tube above evaporator and see that it is distributing the water properly and evenly over the front of the evaporator. See Fig. 7.
5. Check all refrigerant and conduit lines to guard against vibrations and possible failure.
6. Turn toggle switch to ice making position. Reach down in to ice chute and push damper door open. Entire ice cuber should stop until damper door is released and cuber should start up again. If adjustment is needed, bend the metal arm of the bin switch until the cuber shuts down with the damper door held open approx. 1 to 1½ inches.
7. Has owner been instructed on how to operate and clean the cuber?
8. Has installation and warranty registration card been filled out? This is for owner protection.
9. Is there 5" clearance around cuber for proper air circulation?
10. Does room maintain a minimum of 55° F during winter months in order to produce ice as per ice production specifications on Page 14?
11. Check water and drain connections for water leaks.
12. Installer should replace control box cover and front panel. Cuber should be checked for two harvest of cubes to see that cuber functions properly.

### SYSTEM CONTROL AND SEQUENCE OF OPERATION (A-0200)

Locate the main power toggle switch. The toggle switch is marked with three positions, left for "water pump", center "off" and right for "ice."

The left (water pump position), is used to check the operation of the pump, circulate cleaning solution through the water distributor system (see cleaning instructions), and check the operation of the ice makeup water float valve, which controls the water level in the sump.

With the toggle switch in the right (ice position), current is placed across the normally closed contacts of the timer relay (terminals 4 & 5). This starts the water pump and condenser fan motor. Simultaneously current is placed through terminal 6, on the terminal board, starting the compressor (see electrical diagram).

As the water flows over the evaporator, heat is transmitted to the refrigerant causing an increase in suction line pressure and temperature. The expansion valve bulb, sensing the increased temperature, causes the expansion valve to modulate open and closed, feeding refrigerant to the evaporator as required. The evaporator pressure during the freeze cycle will start at approx. 20 PSIG and drop to approx. 7 PSIG.

As the water temperature is lowered and ice begins to form on the evaporator the suction line pressure and the temperature decrease.

As the suction line pressure is decreasing, it is monitored by a reverse acting low pressure control. At a predetermined pressure (9 PSIG reg. cube, 11 PSIG dice cube, & 12 PSIG half dice cube) the contacts within this control close energizing the timer delay circuit (terminal "1"). The timer delay circuit is adjustable, and is used to set the desired bridging between ice cubes.

At the end of the timing sequence the relay of the solid state timer will energize. The relay's normally closed contacts, between terminals 4 & 5, will open shutting off the water pump and condenser fan motor, and closes its normally open contacts, between terminals 3 & 4, energizing the hot gas solenoid. (The cuber can be placed in the harvest at any point during the freeze cycle by shorting across timer terminals 3 & 4 or terminal H & H<sub>1</sub> depending on the make timer. Caution: Shorting across wrong terminals could damage timer.)

With the cuber in the harvest cycle the suction pressure will rise above 30 PSIG opening the low pressure control contacts. The timer relay remains energized through the timer interlock circuit.

The hot gas will warm the evaporator releasing the ice, allowing the ice to fall through the ice chute. As the ice drops through the chute, the ice will open the damper door, momentarily tripping the bin switch and de-energizing the cuber. The solid state timer relay will return to its normal position, de-energizing the hot gas solenoid and energizing the water pump and condenser fan motor. The cuber is now in a new freeze cycle.

Within the electrical system there are two safety controls to protect your cuber. The first is a thermostat attached to the suction line, this control opens on a raise in suction temperature to terminate the harvest cycle, and protect the cuber from overheating should the damper door switch fail. The second is a high pressure cut-out switch (water cooled units only) opening on a raise in condensing pressure to stop the entire unit. This control protects water cooled units in the event the water is shut off, or the condenser becomes contaminated with impurities from the water.

## CONTROLS

### High Pressure Cut-Out

This shuts entire machine off, should the head pressure exceed 275 PSIG. (Water cooled only).

### Suction Line Thermo Disc (Thermostat)

Suction line thermo disc is a safety control located on suction line. This control is a Klaxon switch that opens at 65°F + -5° and closes at 35°F + -5°. The thermo disc acts only as a safety device to prevent overheating of the cuber. Should the damper door switch fail after harvest, the thermo disc will open. When the suction line temperature reaches 65° + -5° this will return the machine to its normal freezing cycle by de-energizing the solid state timer & hot gas solenoid.

### Toggle Switch

The main power "ON and OFF" toggle switch is a double pole, double throw switch with "OFF" in the center position. With the toggle switch in the "water pump" (Left) position, only the water pump and the condenser fan operate. This is for checking the water inlet float level, pump operation, and for circulating cleaning solution.

With the toggle switch in the "ICE" (Right) position, the water pump, compressor and condenser fan (air cooled models), run for a normal ice making cycle.

### Low Pressure Cut-In Control

This control is a reverse-acting pressure control that closes on a fall-in pressure. Upon decrease in suction pressure (12 PSIG half dice, 11 PSIG dice, & 9 PSIG reg. cube), the pressure control closes, actuating the timer.

### Damper Door Switch

When the harvest is completed, the ice falls through the damper door tripping the damper door switch. This, in turn, de-energizes the timer relay returning the machine to its normal freeze cycle.

When the ice bin is full, the ice holds the bin switch open keeping the machine shut off.

Should the damper switch fail, the suction line thermo disc will open to reset the timer.

### Water Regulating Valve (Water Cooled Only)

The water regulating valve is mounted in the water inlet line of the condenser. The water valve is used to control the head pressure by regulating the water flow through the condenser. The valve has an adjustment located on the head of the valve. To set the head pressure, install a high side gauge and adjust the water regulating valve until 125 PSIG head is reached.

### Solid State Timer

When suction line pressure has dropped low enough the low pressure control will close activating the time delay circuit of the solid state timer. The length of the time delay is adjusted as shown below. When the time cycle has elapsed the timer will lock in its own lock-in relay, cycling the ice cuber into hot gas or harvest cycle. Simultaneously, the water pump (and condenser fan on air cooled models) are shut off.

**NOTE:** Series 200 ice cubers are manufactured with several different style solid state timers. These timers are interchangeable with one another. Should it be necessary to have to replace one with the other the wiring will be the same. The only thing to be sure of is that the numbered wires are placed on the terminals with corresponding numbers.

### SETTING SOLID STATE TIMER FOR ICE BRIDGE THICKNESS

Should it be necessary to adjust the timer for an accurate bridge thickness, proceed as follows:

1. Remove cover from the control box Fig. 4.
2. Locate timer.
3. To increase rotate dial clockwise.
4. To decrease rotate dial counter-clockwise.  $\frac{1}{4}$  turn equals approximately 5 minutes.

For optimum ice production and maximum cube separation, the ice connecting the individual cubes should be  $\frac{1}{8}$ " thick at the center of the ice "waffle" (Note: Bridging will vary in the thickness from the top to the bottom of evaporator).

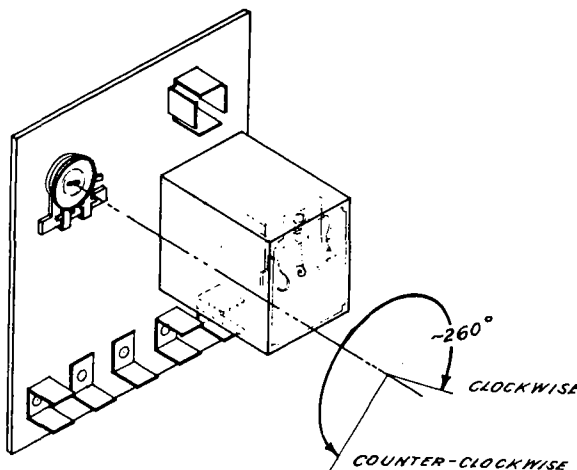
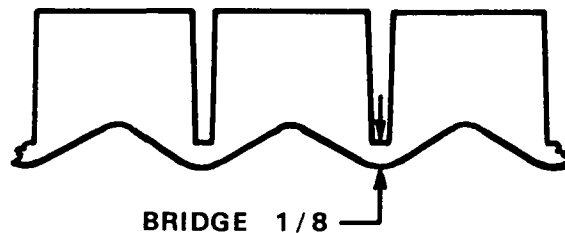

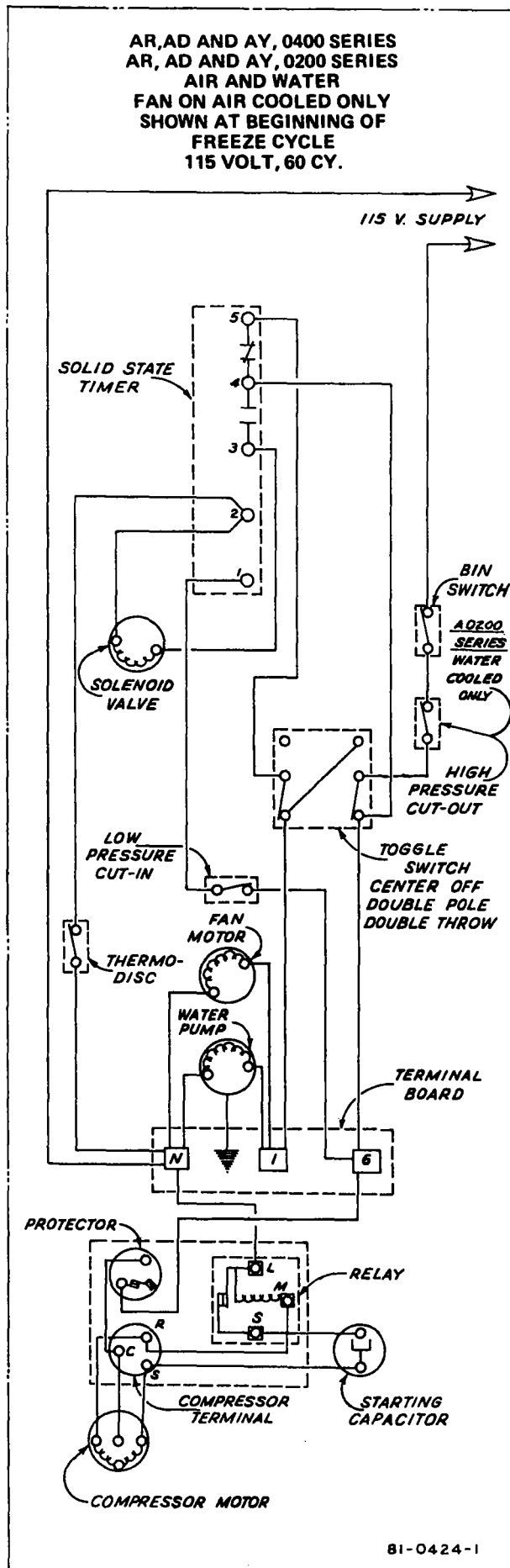

FIG. 1

81-0424-1

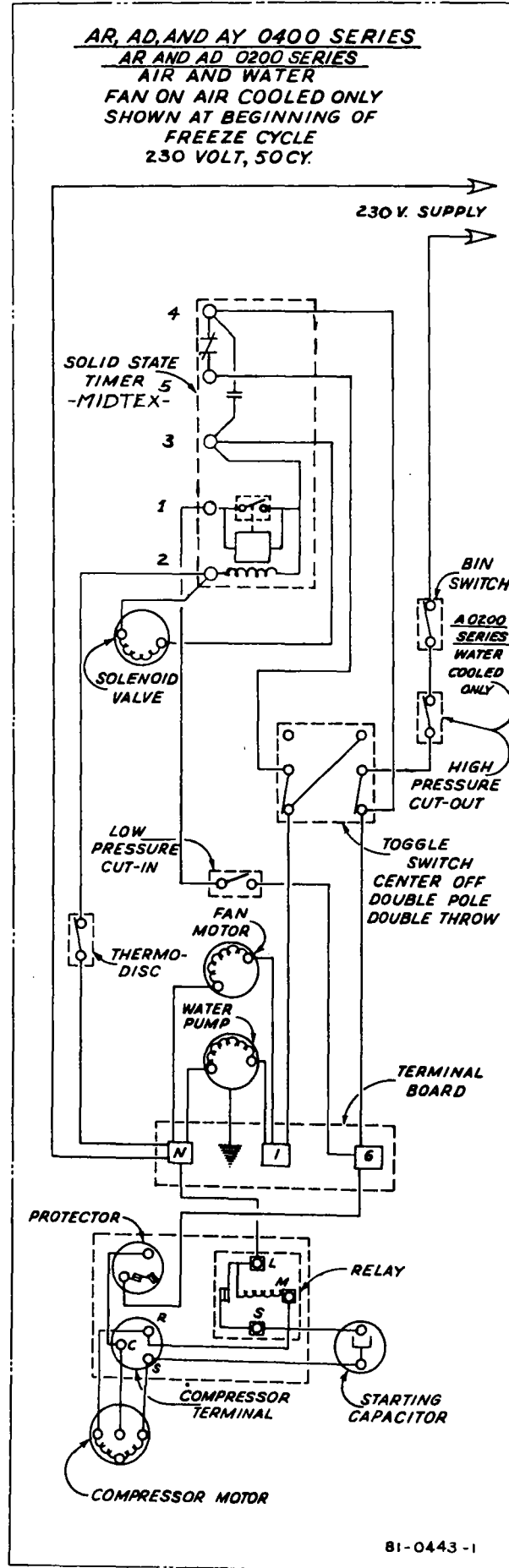
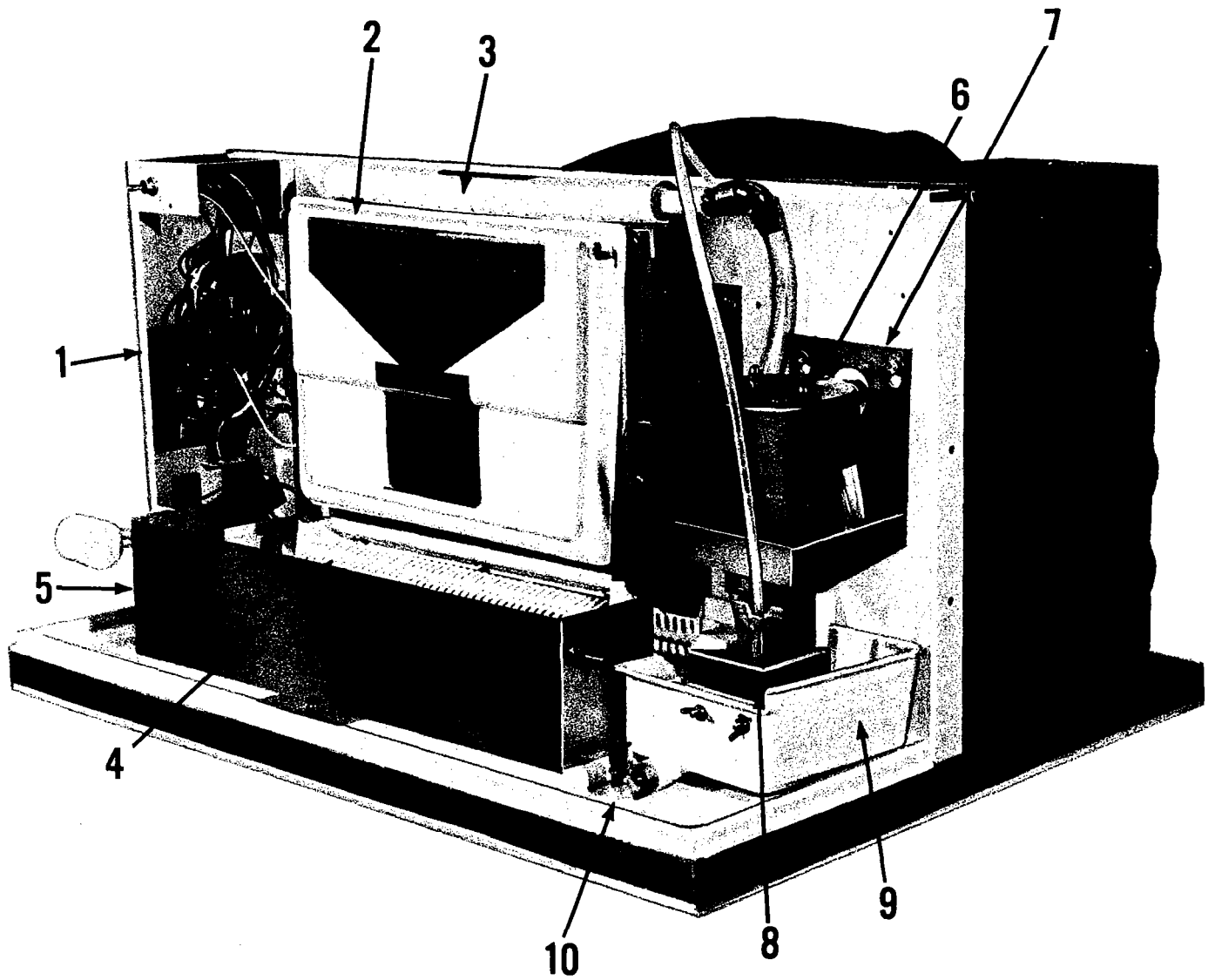
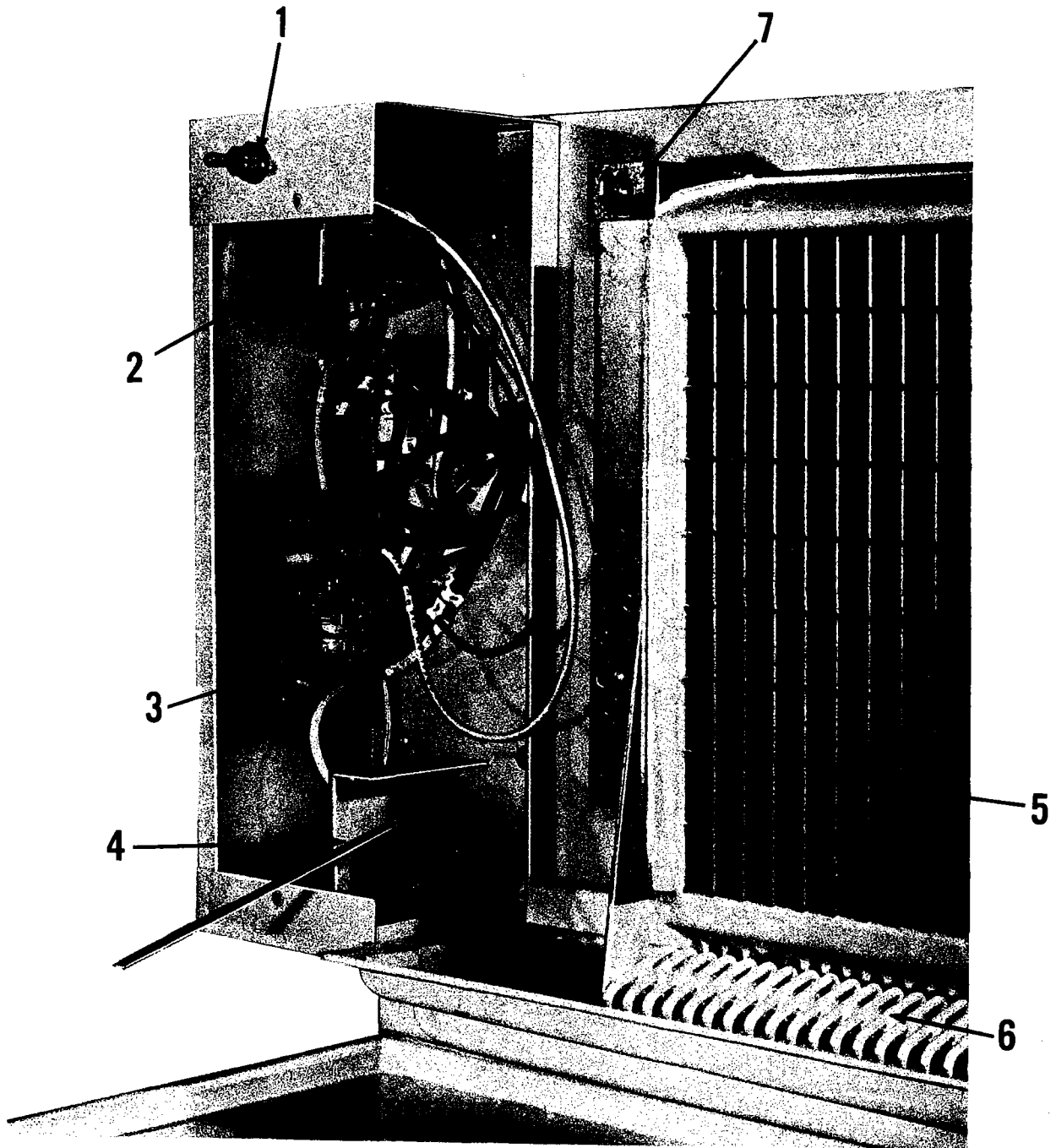

FIG. 2



**FIG. 3 — ICE MAKING COMPARTMENT**

- 1. Control box.
- 2. Water curtain.
- 3. Water distributor.
- 4. Harvest rack.
- 5. Ice chute & damper door assy.
- 6. Water pump.
- 7. Water pump mounting bracket.
- 8. Float valve & bracket.
- 9. Water sump.
- 10. Overflow elbow.



**FIG. 4 — CONTROL BOX**

- 1. Main toggle switch.
- 2. High pressure cut-out (water cooled only).
- 3. Timer (solid state).
- 4. Damper door micro switch.
- 5. Evaporator.
- 6. Harvest rack.
- 7. Water curtain hook (left side).

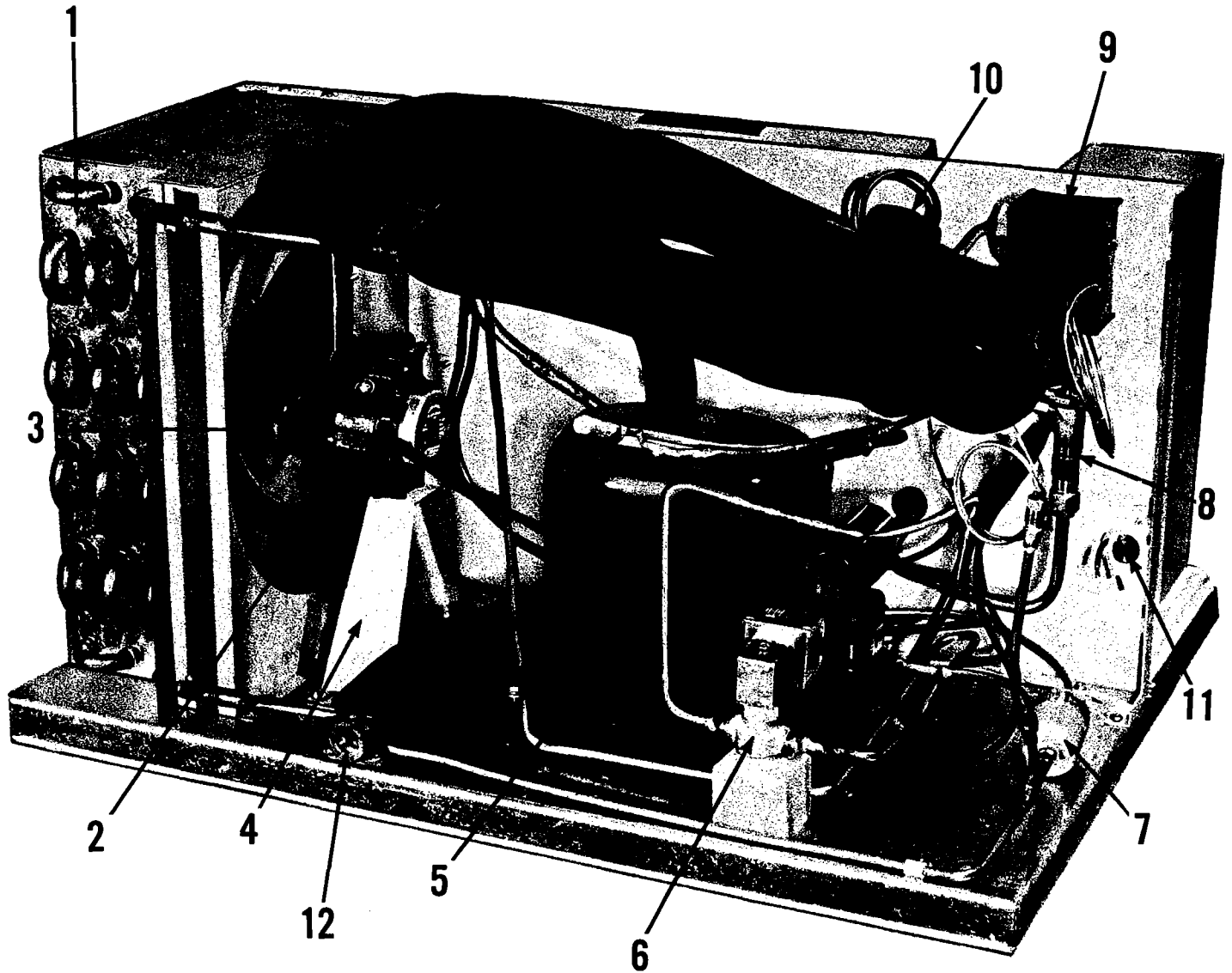

FIG. 5 — COMPRESSOR COMPARTMENT (AIR COOLED)

1. Air cooled condenser.
2. Condenser fan motor.
3. Condenser fan blade.
4. Condenser fan motor mounting stand.
5. Compressor.
6. Hot gas solenoid valve.
7. Drier.
8. Expansion valve.
9. Low pressure cut-in.
10. Thermodisc.
11. Electrical supply hole.
12. Ice water supply connection.

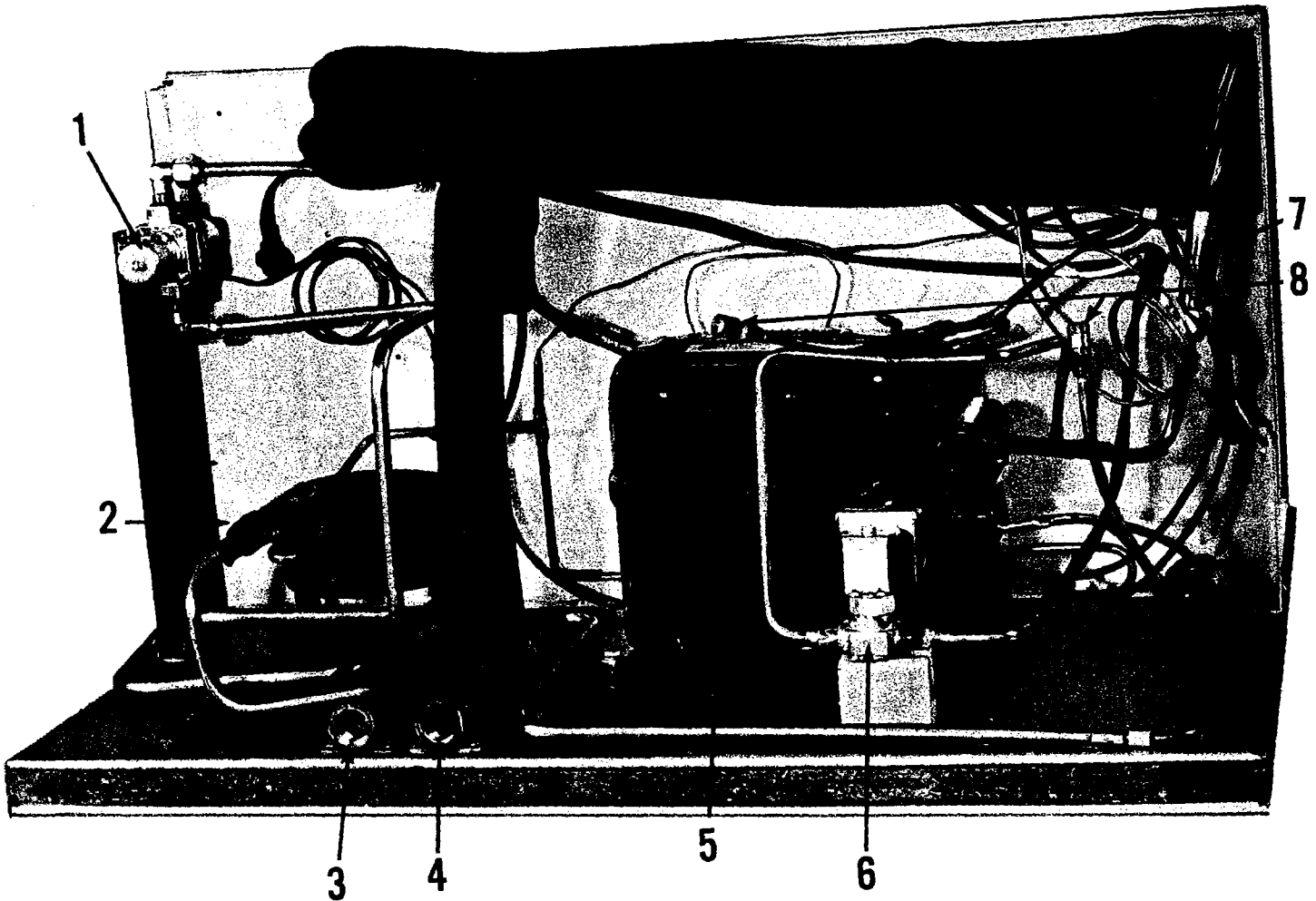
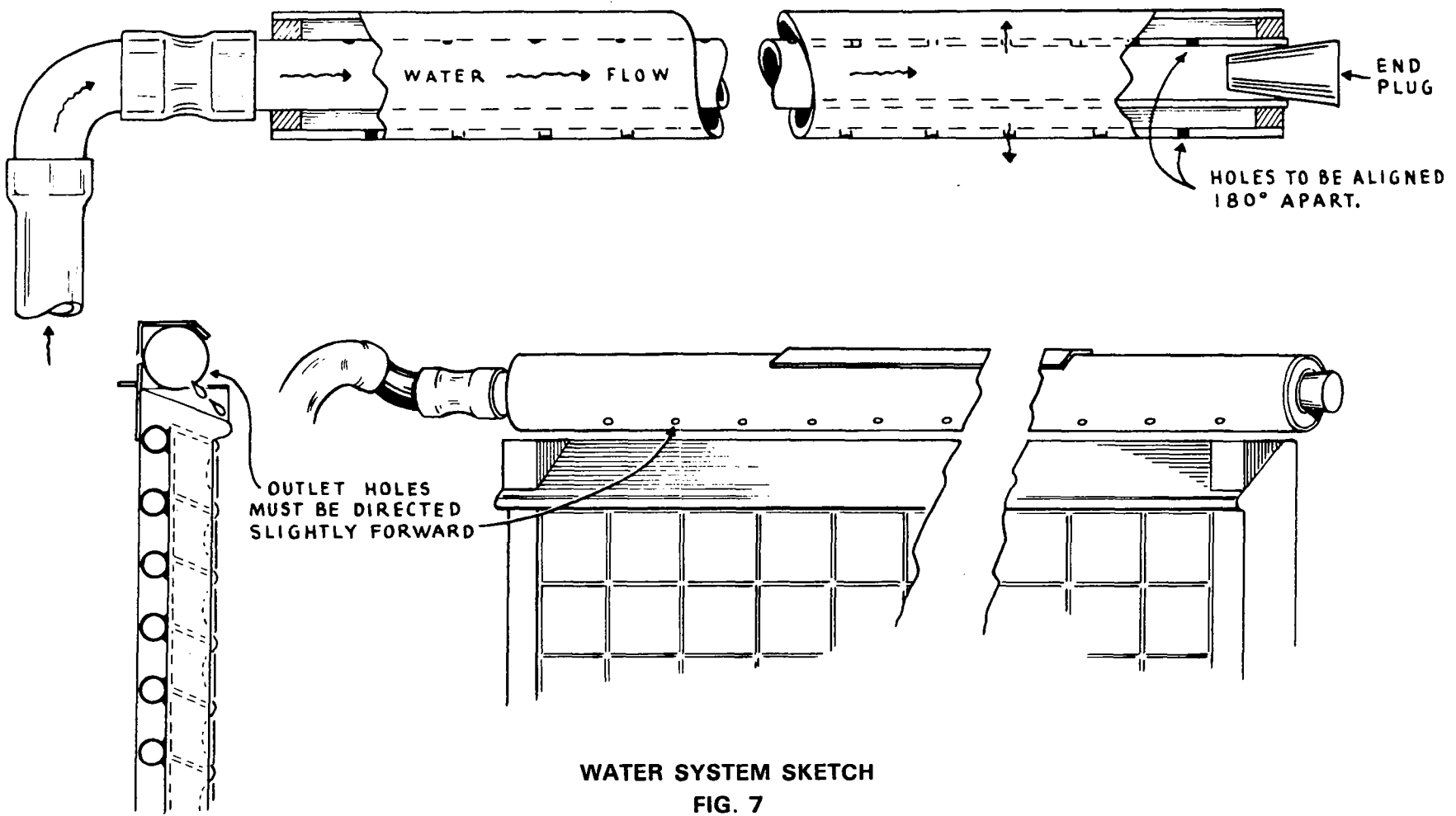

FIG. 6 — COMPRESSOR COMPARTMENT (WATER COOLED)

- 1. Water regulating valve.
- 2. Water cooled condenser.
- 3. Condenser water drain connection.
- 4. Ice & condenser water supply.
- 5. Compressor.
- 6. Hot gas solenoid valve.
- 7. Expansion valve.
- 8. Service port (air & water cooled units).



WATER SYSTEM SKETCH  
FIG. 7

MANITOWOC A-0200 SERIES HEAD SECTION  
GENERAL SPECIFICATIONS

ICE PRODUCTION — lbs. per 24 hours

| "200" SERIES ICE PRODUCTION (Pounds per 24 Hours)* | Incoming Water Temp. F |     | Room Temperature F |     |     |
|--|------------------------|-----|--------------------|-----|-----|
|  |                        | F   | 70°                | 80° | 90° |
|  | Air Cooled Models      | 50° | 195                | 175 | 155 |
|  | 70°                    | 175 | 160                | 145 |     |
|  | 90°                    | 155 | 140                | 125 |     |
| Water Cooled Models                                | 50°                    | 180 | 170                | 165 |     |
|  | 70°                    | 160 | 150                | 145 |     |
|  | 90°                    | 150 | 140                | 135 |     |

| * A-0200 CONDENSER WATER CONSUMPTION |     |     |      |
|--------------------------------------|-----|-----|------|
| Incoming Water Temperature °F        | 50° | 70° | 90°  |
| Gals./24 Hr. Running Time            | 145 | 265 | 1020 |

\*Approximate production for Dice cube, Half Dice and Regular cube.

\*These figures are based on a head pressure setting of 125 PSIG. The consumption rate can vary depending on the condenser operating conditions.

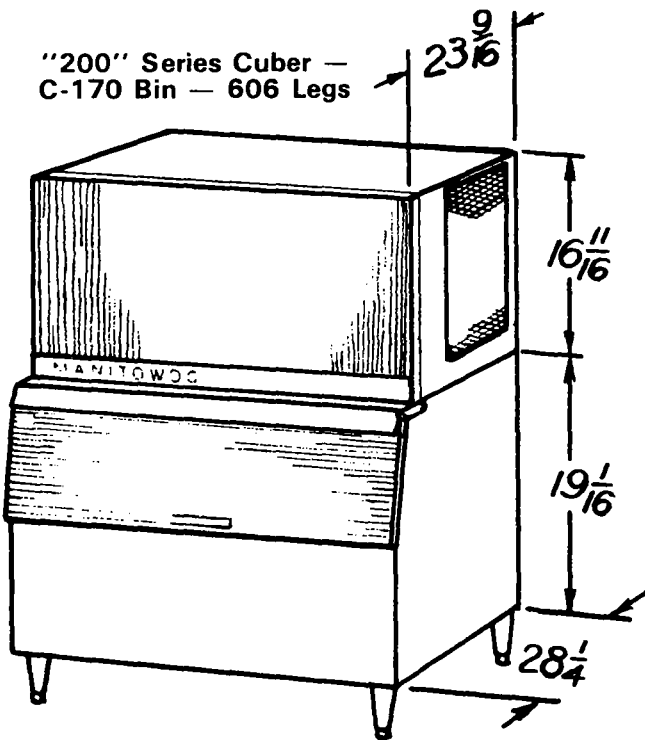
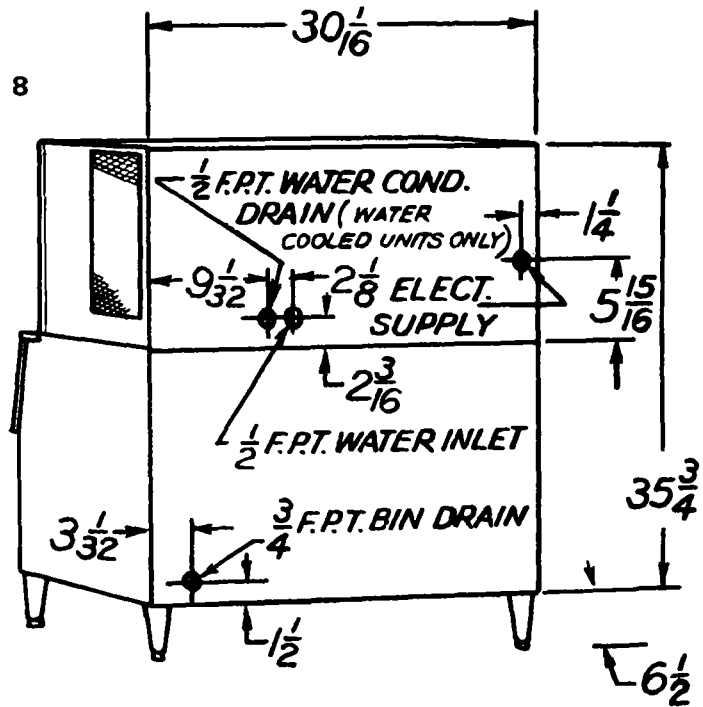

FIG. 8



| "200" SERIES MODELS | Cube Type | Condenser | Exterior Finish | Approx. Ship. Wt. — lbs. |
|---------------------|-----------|-----------|-----------------|--------------------------|
| AR-0200A            | Regular   | Air       | Fawn            | 180                      |
| AR-0200AS           | Regular   | Air       | Stainless       | 180                      |
| AR-0201W            | Regular   | Water     | Fawn            | 175                      |
| AR-0201WS           | Regular   | Water     | Stainless       | 175                      |
| AD-0202A            | Dice      | Air       | Fawn            | 185                      |
| AD-0202AS           | Dice      | Air       | Stainless       | 185                      |
| AD-0203W            | Dice      | Water     | Fawn            | 180                      |
| AD-0203WS           | Dice      | Water     | Stainless       | 180                      |
| AY-0204A            | Half Dice | Air       | Fawn            | 190                      |
| AY-0204AS           | Half Dice | Air       | Stainless       | 190                      |
| AY-0205W            | Half Dice | Water     | Fawn            | 185                      |
| AY-0205WS           | Half Dice | Water     | Stainless       | 185                      |

| "200" SERIES BIN OPTIONS    | C-170   | C-400  | C-160*  | C-900* |
|-----------------------------|---------|--------|---------|--------|
| Ice Storage ** — lbs.       | 220     | 430    | 580     | 1040   |
| Height (inches)             | 19-1/16 | 31-3/8 | 31-7/16 | 44     |
| Width (inches)              | 30-1/16 | 30     | 48      | 48     |
| Depth (inches)              | 28-1/4  | 34     | 29-9/32 | 34     |
| Approx. Shipping Wt. — lbs. | 65      | 116    | 163     | 270    |
| Carton Volume — Cu. ft.     | 12.5    | 24     | 32.5    | 49     |

NOTES: Bin Legs are cast aluminum. No. 606 adjustable from 6-1/2" to 7-1/2" — No. 612 adjustable from 12" to 13-1/2".  
\*E-302S Bin Adapter. \*\*Rated storage capacity is based on 35 lbs. per cubic foot at 90% of internal volume.

DIMENSIONS: (All Models) Height 16-11/16" — Width 30-1/16" — Depth 23-9/16"

ELECTRICAL CHARACTERISTICS: 115 VAC — 60 Hertz Single phase. Minimum Ampacity 13.4 Amps.

COMPRESSOR: 1/3 Horsepower.

60 HERTZ

| Cuber Model                       | AR, AD & AY-200 Series Water Cooled | AR, AD & AY-200 Series Air Cooled |
|-----------------------------------|-------------------------------------|-----------------------------------|
| Compressor Model                  | JFH1-0033-1AA                       | JFB1-0033-IAA                     |
| Compressor Voltage                | 115V-60Cy-1Ph                       | 115V-60Cy-1Ph                     |
| Winding Resistance                |                                     |                                   |
| Common to Run                     | 1.2 OHMS                            | 1.2 OHMS                          |
| Winding Resistance                |                                     |                                   |
| Common to Start                   | 2.9 OHMS                            | 2.9 OHMS                          |
| Start Capacitor Rating            | 233-280 MFD 110V                    | 233-280 MFD 110V                  |
| Fan Motor Model                   |                                     | MORRILL                           |
| Fan Motor Amps                    |                                     | .82                               |
| Fan Motor Volts                   |                                     | 115 Volts                         |
| Fan Winding Resistance            | 28 OHMS                             | 28 OHMS                           |
| Solenoid Valve Volts              | 115V                                | 115V                              |
| Solenoid Valve Winding Resistance | 49 OHMS                             | 49 OHMS                           |
| Water Pump Winding Resistance     | 9.5 OHMS                            | 9.5 OHMS                          |
| Water Pump Amperage               | 1.8 Amps                            | 1.8 Amps                          |
| Refrigerant Charge — R-12         | 10 ozs.                             | 21 ozs.                           |
| Normal Cuber Amperage             | 6.7 Amps                            | 9.0 Amps                          |
|                                   | <b>Room Temperature °F</b>          | <b>70 80 90</b>                   |
| <b>FREEZE CYCLE</b>               | HEAD Beginning of Cycle (PSIG)      | 125 125 125                       |
|                                   | PRESSURE End of Cycle (PSIG)        | 125 125 125                       |
|                                   | SUCTION Beginning of Cycle (PSIG)   | 21 22 22                          |
|                                   | PRESSURE End of Cycle (PSIG)        | 6 7 8                             |
| <b>HARVEST CYCLE</b>              | HEAD PRESSURE                       | 75 — 120 PSIG                     |
|                                   | SUCTION PRESSURE                    | 30 — 60 PSIG                      |

50 HERTZ

| Cuber Model                 | AR, AD & AY-200 Series Water Cooled | AR, AD & AY-200 Series Air Cooled |
|-----------------------------|-------------------------------------|-----------------------------------|
| Compressor Model            | RSH2-0050-IAG                       | RSH2-0050-IAG                     |
| Compressor Voltage          | 230V-50Hz-1Ph                       | 230V-50Hz-1Ph                     |
| Compressor Winding          |                                     |                                   |
| Resistance "C" to "R"       | 1.2 OHMS                            | 1.2 OHMS                          |
| Compressor Winding          |                                     |                                   |
| Resistance "C" to "S"       | 7.6 OHMS                            | 7.6 OHMS                          |
| Start Capacitor             | 41-53 MFD 220V                      | 41-53 MFD 220V                    |
| Fan Motor Voltage           |                                     | 230V                              |
| Fan Motor Amps              |                                     | .5A                               |
| Fan Winding Resistance      |                                     | 20 OHMS                           |
| Water Pump Voltage          | 230V                                | 230V                              |
| Water Pump Amp              | .77A                                | .77A                              |
| Pump Winding Resistance     | 46.5 OHMS                           | 46.5 OHMS                         |
| Solenoid Valve Voltage      | 230V                                | 230V                              |
| Solenoid Winding Resistance | 22 OHMS                             | 22 OHMS                           |
| Refrigerant Charge          | 10 oz.                              | 21 oz.                            |
|                             | <b>Room Temperature °F</b>          | <b>70 80 90</b>                   |
| <b>FREEZE CYCLE</b>         | HEAD Beginning of Cycle (PSIG)      | 125 125 125                       |
|                             | PRESSURE End of Cycle (PSIG)        | 125 125 125                       |
|                             | SUCTION Beginning of Cycle (PSIG)   | 10 11 13                          |
|                             | PRESSURE End of Cycle (PSIG)        | 0 2 2                             |
| <b>HARVEST CYCLE</b>        | HEAD PRESSURE                       | 75 — 120 PSIG                     |
|                             | SUCTION PRESSURE                    | 30 — 60 PSIG                      |

**SERVICE ANALYSIS**

| <u>COMPLAINT</u>                         | <u>CAUSE</u>   | <u>CORRECTIVE MEASURES</u>  |
|--|--|---|
| Slow harvest                             | Contaminated or limed water system<br>Low ambient (air cooled models)<br>Water valve set too low<br><br>Leaking water valve (water cooled models)  | Clean water system<br>Must be above 55° F<br>Adjust water valve to 125 PSIG head pressure (Water cooled models)<br>Replace water valve                      |
| High head pressure                       | Air in system<br>Defective water valve (water cooled models)<br>Defective fan (air cooled models)<br>Water valve not properly adjusted (Water cooled models)<br>Contaminated air cooled condenser<br>Defective expansion valve | Evacuate and recharge<br>Replace water valve<br><br>Replace fan<br>Adjust water valve<br><br>Clean condenser<br>Replace                                     |
| High suction pressure                    | Leaky hot gas valve<br><br>Moisture in system  | Clean seat or replace valve<br>Replace drier, evacuate and recharge   |
| Low suction pressure                     | Defective expansion valve<br>Shortage of refrigerant<br>Moisture in system<br><br>Ambient too low for operation  | Replace<br>Locate leak and repair<br>Replace drier, evacuate system<br>Must be above 55° F  |
| Unit noisy                               | Tubing touching each other<br><br>Fan shroud touching fan blades<br><br>Loose fan blade  | Separate tubing so it does not touch<br>Adjust fan mounting brackets<br>Tighten fan blade   |
| Ice maker will not stop when full of ice | Damper door not properly adjusted<br>Defective door micro switch   | Adjust damper door (1-1½")<br>Replace damper door micro switch  |
| Timer will not operate                   | Pressure control not closing<br><br>Suction pressure not dropping low enough<br><br>Timer defective<br>Thermo disc is not closed   | Replace control or properly adjust<br>Possible expansion valve or hot gas valve problem<br>Replace timer<br>Check thermo disc                               |
| Small cubes or deep dipples              | Timer set too low<br>Pressure control not opening after harvest<br>Leak in refrigeration system<br><br>Shortage of water   | Adjust clockwise<br>Replace control<br><br>Locate leak, repair, evacuate and recharge<br>Check float valve & supply tubing                                  |
| Machine will not cycle into harvest      | Defective time clock<br>Defective thermo disc or thermo disc loose on suction line<br>Bad hot gas valve coil<br>Bad low pressure cut-in control<br>Low side pressure not getting low enough to actuate pressure control        | Replace<br>Replace or tighten on suction line<br>Replace valve coil<br>Check & adjust or replace if necessary<br>Bad expansion valve or leaky hot gas valve |

**SERVICE ANALYSIS cont.**

| <u>COMPLAINT</u>                     | <u>CAUSE</u>  | <u>CORRECTIVE MEASURES</u>   |
|--------------------------------------|---|--|
| Unit will not run                    | Blown fuse<br><br>Switch in Off position<br>Inoperative main toggle switch<br>Out on high pressure cut-out<br>(Water cooled models)<br>pressure control | Replace fuse & check for cause of blown fuse.<br>Turn switch to On position<br>Replace switch<br>Repair cause of high head pressure & reset  |
| Compressor cycles intermittently     | Low voltage<br><br>Dirty condenser<br><br>Air circulation blocked<br><br>Inoperative condenser fan motor<br>Non-condensable gases in system             | Check circuit for overloading.<br>Check voltage at the supply to the building.<br>If low, contact the power company.<br>Clean with vacuum cleaner air or stiff brush. (DO NOT USE WIRE BRUSH)<br>Allow sufficient air space all around unit.<br>Check to see if defective<br>If defective, replace<br>Purge the system |
| Irregular size cubes and some cloudy | Holes in water distributor tube plugged<br>Shortage of water<br><br>Unit not level<br>Water distributor tube not properly adjusted                      | Clean distributor tube<br><br>Check water pump & water level in sump trough<br>Check and level.<br>Adjust  |
| Large cube bridge                    | Timer set too high<br>Low side control set too low  | Adjust counter clockwise<br>Raise setting on low side control  |
| Decreased ice capacity               | Leaky hot gas valve<br><br>High head pressure<br><br>Water level set too high, overflowing elbow during freeze  | Clean or replace valve<br>Dirty condenser. Clean.<br>Bad fan motor. Replace Non-condensable gas in the system. Purge the system.<br>Too hot a location with poor circulation: Relocate the unit, or provide for proper ventilation. Overcharge of refrigerant, correct the charge.<br>Adjust float valve               |

## CLEANING INSTRUCTIONS

### IN PLACE CLEANING

To clean the ice cuber water system without removing the components proceed as follows: NOTE — This is only recommended in locations where impurity build-up is not heavy.

1. Remove ice cuber front panel.
2. Shut off ice cuber.
3. Remove ice from bin.
4. Shut off water supply and remove water from water sump.
5. Pour one bottle of ice machine cleaner into sump and turn supply water on.
6. Place toggle switch to water pump position and circulate cleaner for about 30 minutes.
7. After cleaning shut machine off and remove cleaner. Flush water system thoroughly.
8. Clean ice storage bin with ice machine cleaner also.

### DISASSEMBLING WATER SYSTEM FOR CLEANING

To clean parts by removing proceed as follows:

1. Shut machine off.
2. Remove splash curtain, water pump and water distributor.
3. Disassemble distributor as indicated in Fig. 7.
4. Disassemble water pump as follows:
  - A. Turn pump over and remove the water inlet screen.
  - B. Hold and depress impeller. Rotate plastic thumb nut counter-clockwise.
  - C. Remove screws and pump housing. Pump is now ready for cleaning.
  - D. Reassemble in reverse order as removed.

Scrub all parts removed using a nylon scouring pad, brushes, and a cleaning solution such as LIME-A-WAY from Economics Laboratory, Inc., or Boss Brand Milk Stone Cleaner from Norther Laboratories. Rinse all parts with clear water.

It is recommended that the ice be removed from the storage bin before scrubbing the base and evaporator assembly. Rinse with clear water. Check to see that overflow or drain hole in the base is clear and that water drains through freely.

Reassemble unit. To sanitize unit, mix ONE TEASPOON OF (CHLORINE BLEACH) SODIUM HYPOCHLORITE IN ONE GALLON OF WATER. Pour solution into sump, then turn toggle switch to the left to start water pump.

Keep pouring solution into sump until system has enough to keep pump primed. After one minute, turn off pump and remove solution from water sump. Repeat with clear water before turning switch back to the ice making position. Make visual inspection for leaks and operation before replacing the front panel.

## SERVICE AND PARTS PROCEDURES

### Ordering Procedure

Replacement parts for Manitowoc ice machine equipment should be ordered directly from your local Manitowoc Ice Machine distributor. Parts are stocked by the distributor in order to provide prompt and efficient service for ice machines sold in their area.

Should you encounter difficulty in locating a Manitowoc distributor in your area, contact the Manitowoc Service/Parts Dept. for name or names of distributors in your area.

When placing your order, be sure to do as follows:

1. Print name and address plainly.
2. If special routing is requested, please show the name of carrier.
3. Indicate quantity desired, print catalogue part number plainly and print name as shown in the catalogue.
4. Indicate model and serial number of the unit. The complete serial number is needed.
5. If uncertain as to the proper part number, please give a complete description or sketch of the part and the location of the part which is needed.
6. Check to see that all required information is contained in your order to facilitate prompt shipment. All replacement parts are shipped from the factory on a f.o.b. Manitowoc basis. It is company policy to bill for all field replacement parts, according to terms as specified by our Credit Department.

All parts orders will be honored by the factory and will be billed according to our parts list schedules.

Parts which are covered by our warranty policy are to be returned to the factory for credit properly packaged, transportation charges prepaid. Upon receipt of these parts here at the factory, they will be inspected; and if they are found to be defective, in material and workmanship, under normal use and service, credit will be issued. Parts not properly packaged will be returned to the sender freight collect.

Transportation companies are responsible for damage in transit as all shipments are tendered to them in good condition; and our responsibility ceases upon receipt of a signed bill of lading from the carrier. If the shipment arrives in a damaged condition or is short, the delivery carrier should be notified immediately.

### Return of Defective Parts

All defective parts returned to the factory, transportation prepaid, must be properly packaged to prevent further damage and tagged with a return material tag properly filled in. It is especially important that the cabinet serial number be secured and recorded on the tag, securing as much information as possible about the nature of the defect to prevent any delays in issuing credit. All parts should be returned as they are removed from the cabinet and not mutilated or tampered with. The return material tags are provided on a no-charge basis by the factory upon receipt of your request. Any part not properly packaged will be returned to the sender freight collect and no credit will be issued.

Our warranty and protection plan does not apply to cabinets that are not registered; therefore, it is necessary that, upon completion of the installation of the cabinet, the registration card be signed on the date of installation and mailed promptly to the factory Service Department in order for the cabinet to be registered.

### Return of Hermetically-sealed Units

Extreme care should be used in servicing the hermetically-sealed mechanism. It is important that the trouble be correctly determined before the unit is changed. Be sure it is not the control, relay, or overload causing the trouble. The defect must be listed on the return material tag. Hermetically-sealed units must be returned with service valves closed and capped. All lines must be pinched and soldered shut.

### Return of Complete Machines

No complete machines may be shipped back to the factory for repairs without first securing prior permission from the factory. If an unauthorized shipment is received at the factory, it will be refused by our warehouse and immediately returned to the sender. Upon receipt of your request to return a cabinet, if we feel that your request is legitimate, you will be sent an authorized return label authorizing you to return this cabinet to the factory freight prepaid.

# Ice Machine and Bin Warranty

From the date of original installation, we do hereby warrant each new Ice Machine and Bin to be free from defects in material and workmanship, under normal use and service, for a period of one year, and four additional years on the hermetic motor compressor in the Ice Machine.

Our obligation under this warranty is limited solely to correcting or replacing without charge at the factory in Manitowoc, Wisconsin any part or parts of this equipment which shall have been returned, transportation prepaid, and which our examination discloses to our satisfaction to be defective.

This warranty does not apply to any equipment that has been damaged by flood, fire, or suffered abuse, misuse, neglect or accident, or to any Ice Machine which has been altered so as to affect performance or reliability, except where such alteration has been accomplished with our prior written consent.

We further limit this warranty in that we shall not be held liable under this contract for any special, indirect, or consequential damages whatsoever resulting from any defect in material and workmanship which interferes with the normal use and service of such Ice Machine and Bin.

This warranty is a complete and exclusive statement of all terms of the agreement between the Manitowoc Equipment Works and the owner of the equipment, and all representations of the parties. This agreement shall not be varied, supplemented, qualified or interpreted by any prior course of dealing between the parties or by any usage of the trade.

Sales are made on the express understanding that there are no express or implied warranties other than the express warranty herein contained and that there are no implied warranties that the goods shall be merchantable or fit for a particular purpose other than the expressed one year and five year warranty set forth above.

To validate this warranty, the registration card must be signed on the date of installation and mailed promptly to the Manitowoc Equipment Works, Manitowoc, Wisconsin.

DEALER \_\_\_\_\_  
\_\_\_\_\_  
\_\_\_\_\_

INSTALLATION DATE \_\_\_\_\_

**MANITOWOC EQUIPMENT WORKS**  
Div. of THE MANITOWOC COMPANY  
500 South 16th Street  
Manitowoc, Wisconsin 54220